

ER MAHI

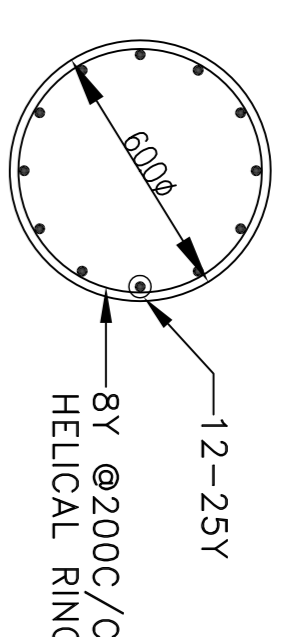

SECTION A-A

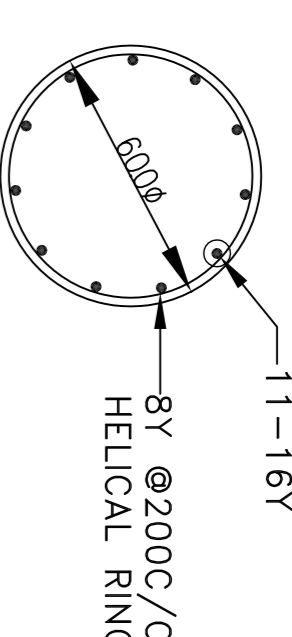

SECTION B-B

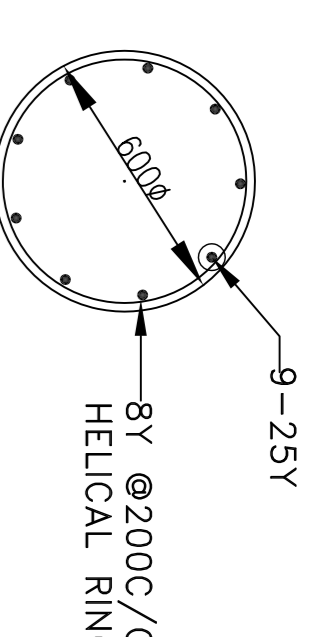

SECTION C-C

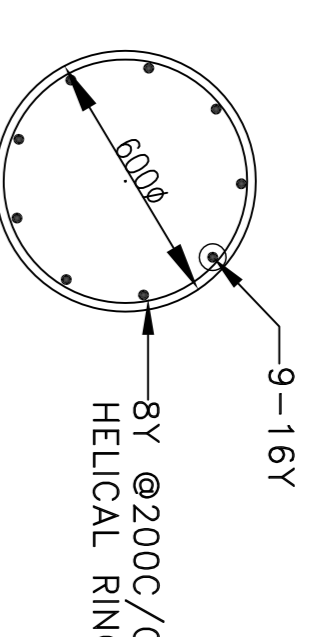

SECTION D-D

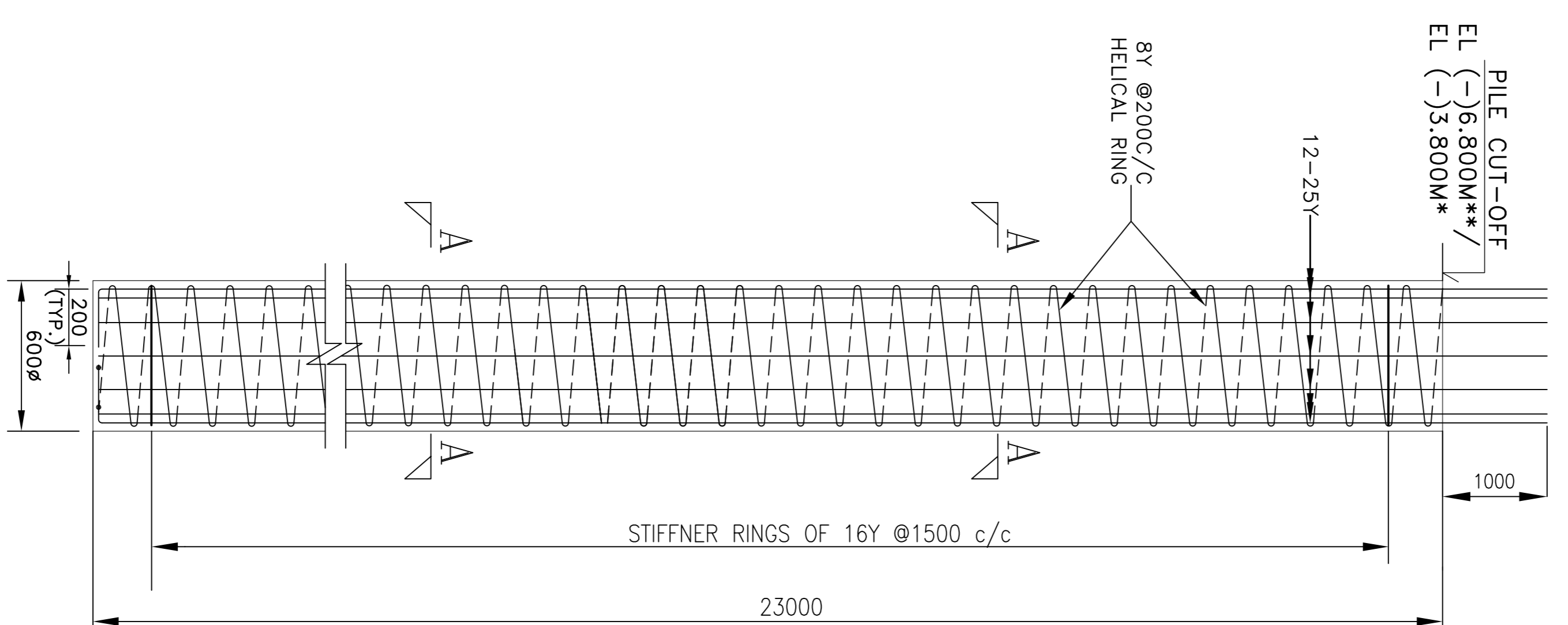

FOR VERTICAL COMPRESSION

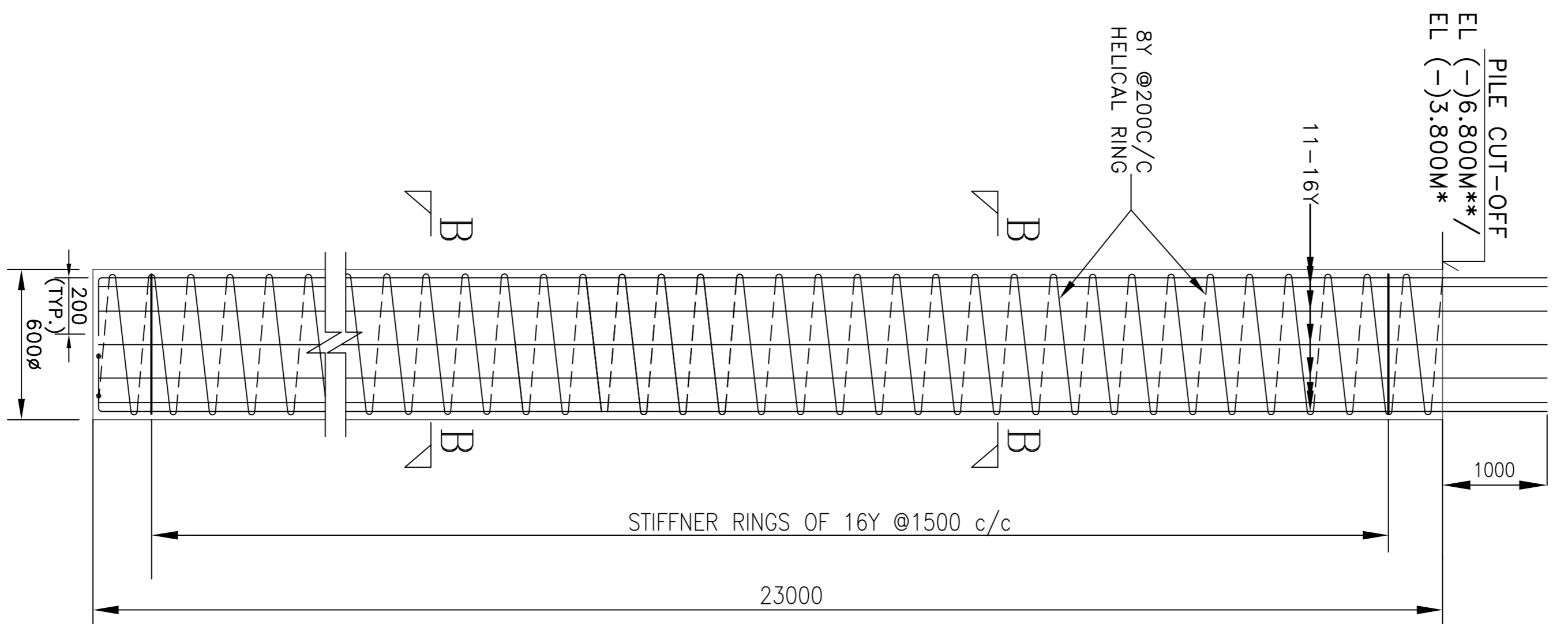

FOR PULL-OUT

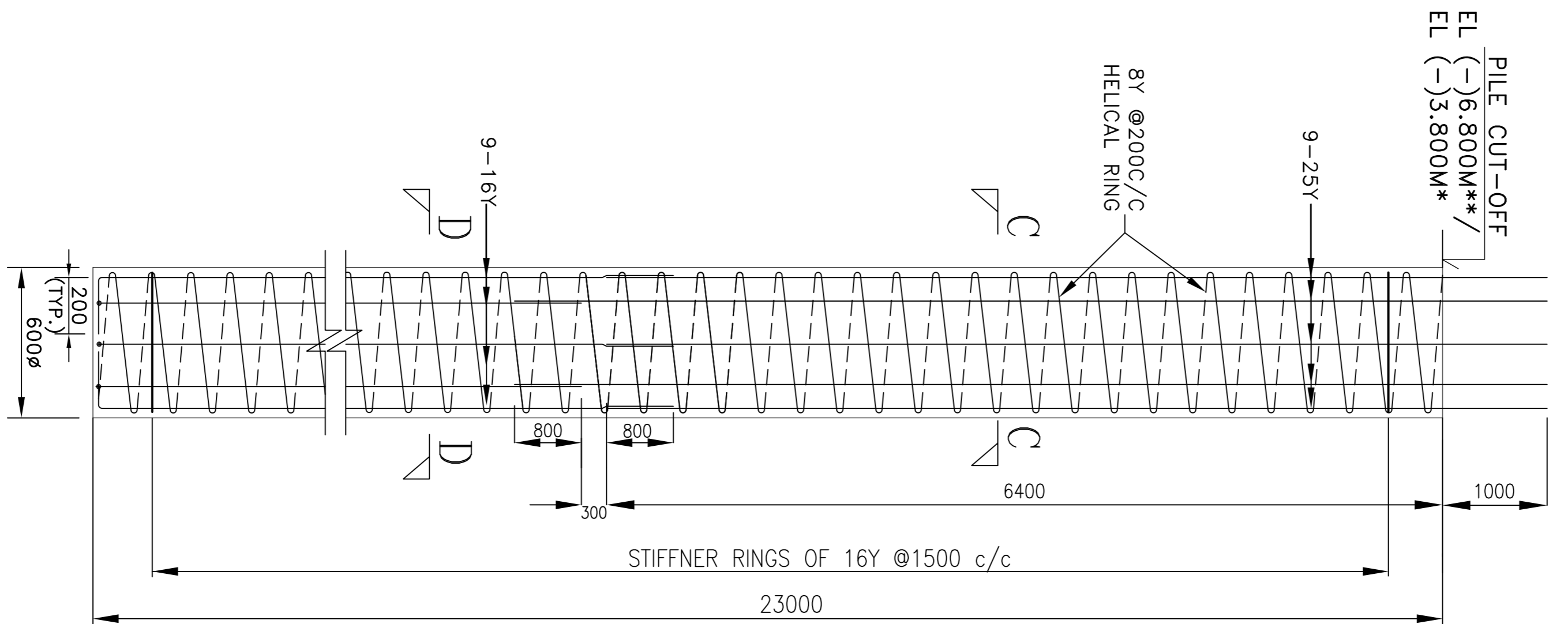

FOR LATERAL LOAD

LOCATION OF TEST PILE (REF. NOTE-13)

TEST AREA	TEST NO.	COORDINATES	DIA OF PILE (MM)	REMARKS
*BOP AREA CUT-OFF LVL EL(-)3.800M	TPH1	499 E 329 N	600	TPH-TEST PILE FOR LATERAL LOAD
	TPV1	504 E 329 N		
	TPP1	509 E 329 N		
	TPH2	587 E 69 N		
**MAIN PLANT AREA CUT-OFF LVL EL(-)6.800M	TPV2	587 E 74 N	600	TPV-TEST PILE FOR VERTICAL COMPRESSION
	TPP2	587 E 79 N		
	TPH3	636 E 95 S		
	TPV3	641 E 95 S		
	TPP3	646 E 95 S		

SAFE LOAD CARRYING CAPACITY OF PILE

DIAMETER OF PILE (MM)	SAFE LOAD (MT)		
	VERTICAL COMPRESSION	PULL OUT	HORIZONTAL
600	150	35	7.0

NOTES:

- ALL DIMENSIONS ARE IN MM AND ELEVATION/LEVEL ARE IN METER UNLESS NOTED OTHERWISE.
- EL.(±) 0.00M CORRESPONDS TO R.L. (+) 72.30M.
- BORED CAST-IN-SITU CONCRETE PILE CONFORMING TO IS:2911 (PART-1/SEC.-2) SHALL BE USED.
- GRADE OF CONCRETE SHALL BE M25 CONFORMING TO IS:456 WITH MINIMUM CEMENT CONTENT OF 400 KG/M³. ORDINARY PORTLAND CEMENT SHALL BE USED.
- REINFORCEMENT STEEL SHALL BE HIGH STRENGTH DEFORMED TMT STEEL BARS OF GRADE Fe 500D CONFORMING TO IS:1786.
- LAP LENGTH SHALL BE 50 TIMES DIAMETER OF BAR. LAPS SHALL BE STAGGERED ALTERNATIVELY.
- CLEAR COVER TO LONGITUDINAL REINFORCEMENT SHALL BE 60MM.
- INITIAL LOAD TEST SHALL BE CONDUCTED UPTO A MAXIMUM TEST LOAD OF TWO AND HALF TIMES THE SAFE LOAD CARRYING CAPACITY OF PILE. VERTICAL COMPRESSION TEST SHALL BE CARRIED OUT BY CYCLIC LOAD METHOD AS PER IS:2911 PART IV.
- TEST SHALL BE CONDUCTED AT PILE CUT-OFF LEVEL.
- CONCRETE SHALL BE CAST TO THE PILING PLATFORM LEVEL TO PERMIT OVERFLOW OF CONCRETE FOR VISUAL INSPECTION OR TO A MINIMUM OF 100MM ABOVE CUT OFF LEVEL.
- TEST RESULTS SHALL BE SUBMITTED TO OWNER/OWNER'S CONSULTANT/BHEL-PEM IMMEDIATELY AFTER COMPLETION OF THE SAME.
- TREME CONCRETING SHALL BE ADOPTED.
- TEST PILE LOCATIONS ARE INDICATIVE ONLY. MINOR MODIFICATIONS (IF REQUIRED) IN TEST LOCATIONS MAY BE DONE AT SITE IN CONSULTATION WITH OWNER.
- LOW STRAIN PILE INTEGRITY TEST SHALL BE CARRIED OUT ON ALL TEST PILES AS PER SPECIFICATION.

REFERENCE:

- REPORT ON GEOTECHNICAL INVESTIGATION WORK FOR 1x800MW WANAKBORI TPS, GUJARAT.
- CUSTOMER'S TECHNICAL SPECIFICATION.
- DRAWING NO. PE-DG-408-100-M001 TITLED, "PLOT PLAN".
- DOCUMENT NO. PE-DC-408-607-0002 TITLED "DESIGN CALCULATION FOR 600MM DIAMETER INITIAL LOAD TEST PILES FOR MAIN PLANT / BOP AREA."

REINFORCEMENT DETAILS OF 600MM DIAMETER INITIAL LOAD TEST PILES

* FOR BOP AREA, ** FOR MAIN PLANT AREA

GUJARAT STATE ELECTRICITY CORPORATION LIMITED
 VADODRA, GUJARAT
 1x800 MW Wanakbori Thermal Power Station, Unit-8
 DEVELOPMENT CONSULTANTS PVT. LTD.
 CONSULTING ENGINEERS
 BHARAT HEAVY ELECTRICALS LTD
 PUNJAB, INDIA
 PROJECTS IN CHARGE: WANAKBORI THERMAL POWER STATION, GUJARAT
 R/C DETAILS OF 600MM DIAMETER INITIAL LOAD TEST PILE
 DRAWING NO. PE-DC-408-607-C002
 SHEET 1 OF 1 REV. 00
 18/10/2015