

## CHAPTER V

### INSPECTION

- 5.1** The whole of the material or fittings used in the construction of the equipment shall be subjected to inspection by the Inspecting authority and shall be to his entire satisfaction.
- 5.2** The inspecting authority shall have the power to :-
- 5.2.1** Adopt any means he may consider necessary to satisfy himself that all the materials or fittings specified are actually used throughout the construction.
- 5.2.2** Visit at any reasonable time and without previous notice, either contractors works or his sub-contractor's works to inspect the manufacturers and the quality of the work at any stage.
- 5.2.3** To reject any materials or fittings that does not conform to the relevant standard specifications or have not been manufactured in accordance with the approved practices. The rejected materials or fittings shall be marked in a distinguishable manner and shall be disposed on in such manner as the inspecting officer may direct to avoid its inadvertent use in the product order as per this specification.
- 5.3** The manufacturer shall offer all the testing facilities free of charge to inspecting authority. Testing of equipment and fittings shall, as far as possible be carried out at the works of the manufacturers. Testing of bought out components may also be carried out at sub-contractor's premises, if so required. The contractor shall provide free of charge, such materials or fittings as may be required for testing whether at his own or his subcontractor's premises. The test for which facilities are not available may be carried out at RDSO or any other approved laboratory for which the testing charges shall be payable by the supplier.
- 5.4** All the equipments and the fittings required for test shall be selected by the inspecting officer and the tests shall be carried out in his presence.
- 5.5** No material shall be packed or despatched until it has been passed by the inspecting officer but the contractors responsibility for its efficiency in every way, shall remain the same as if the work had been manufactured and tested by himself.
- 5.6** Should any part required alteration or any defect appear during the test or trial the contractor shall without any extra charges make such alteration or rectify the defects to the satisfaction of the inspecting authority.
- 5.7** Copies of Maker's test certificate, guarantee the performance of the equipment shall be supplied in duplicated along with the delivery of each unit.

## CHAPTER VI

### TESTS

#### 6.1 CATEGORIES OF TEST

- 6.1.1 TYPE TEST:** Type test shall be carried out on equipment of the approved design. If there is any change in design or source of supply of any components/sub-components/assembly, units made to the changed design or from new source shall be treated as new item for the purpose of conducting type tests.
- 6.1.1.1** Type tests are to be repeated in case of any major change is made. In case of minor changes, i.e. change in type, rating of component etc., special test/tests as agreed by user and manufacturer are to be conducted to ensure their suitability and effectiveness of the modifications.
- 6.1.1.2** The type tests shall be repeated once in three years by RDSO
- 6.1.2 ROUTINE TEST:** Routine test shall be carried out in every equipment of each order.
- 6.1.3 ACCEPTENCE TEST:** Acceptance Test shall be carried on 10% of batch quantity subject to minimum of 5 nos. as per table given below.
- 6.2** Tests will be carried out on the prototype unit as per relevant IEC specification or mutually agreed test program. Manufacturer will bear the expenses of the tests.
- 6.2.1** The tests to be carried out on complete unit are given in the following table together with the clause number of IEC 60571 to which reference should be made.

Sl. No	TESTS	IEC CLAUSE NO.	SPEC. CLAUSE NO.	TYPE TEST	ROUTINE TEST	ACCE PT. TEST
1.	Visual Inspection	10.2.1	6.3.1	✓	✓	✓
2.	Performance test	10.2.2	6.3.2	✓	✓	✓
3.	Cooling Test	10.2.3	6.3.3	✓		
4.	Temperature rise test (Dry heat)	10.2.4	6.3.4	✓		
5.	Temperature rise (damp heat)	10.2.5	6.3.5	✓		
6.	Supply over voltage, Surges and electrostatic discharge test	10.2.6	6.3.6	✓		✓
7.	Transient burst susceptibility test	10.2.7	6.3.7	✓		
8.	Radio Interference test	10.2.8	6.3.8	✓		

9.	Insulation test	10.2.9	6.3.9	✓	✓	✓
10.	Dielectric test	10.2.10	6.3.10	✓	✓	✓
11.	Vibration and shock test	10.2.11	6.3.11	✓		
12.	Reverse polarity test		6.3.12	✓	✓	✓
13.	Output short circuit test		6.3.13	✓	✓	✓
14.	Dust test		6.3.14	✓		
15.	Reliability test		6.3.15	✓	✓	✓*
16.	Efficiency test		6.3.16	✓		✓

\* On 5% of the lot offered or a minimum of 2 nos.

### 6.3 TESTS:

#### 6.3.1 VISUAL INSPECTION:

- (a) The initial visual inspection shall be carried out to ensure that the equipment is of sound construction, good workmanship, free from defect and meet the specification requirements. The inspecting authority is free to point out defects /checks. However, for guidance some checks are given below. -
- (b) Dimensional check, mounting dimensions fastening arrangement, knob, terminals, switches, indications, serial numbers, type numbers, terminal marking etc. are correct as per approved drawings and free from defects i.e. missing nuts/bolts, sharp edges, cracks/broken terminals/knobs, worn screws/ too tight, dents, scratches, deformation of fins, fixing holes too close to edges, loose screws etc.
- (c) Main component i.e. diodes, transistor, power transistor, IC's etc. are as per approved drawings and material.
- (d) The protective-cum-adhesive coating used on PCB's is clear, transparent, not affecting colour code of electronic components and type number of devices and is in dry conditions. Heavy components are properly tied or fixed. The soldered connections are with good finish, no peeling off copper connecting circuit path/ repaired by solder or jumper and the surface is coated with solderable protection coating.
- (e) All the resistors, capacitors, semi-conductor devices and other components mounted on PCB's are with round bend instead of sharp 90 deg bends, the height of components is uniform and minimum to avoid breakage, overhang/cantilever mountings of components has been avoided, heavy components are tied down with PCB's, resistors of more than 5 watts are provided with heat resistant sheet below to avoid burning of PCB's and heat dissipating components are separately mounted.

- (f) Standard and good code of practice has been followed i.e. wiring are properly laid, tied, terminated, colour code followed, mounting pads have been used for IC's/transistors where necessary, no repaired PCB's have been used. No hylam PCB has been used.
- (g) Check that all nuts, bolts, spring washers, washers and other parts used are galvanised or plated. Hexagonal head bolts provided with slot for screw driving have been used. Welded nut construction is preferable instead of threads in housing sheet metal.
- (h) Anodised rating plate, engraved terminal marking have been provided, indications, switches, terminal etc. are marked as per drawing.
- (i) Normally the manufacturer have a check list to avoid mistakes/missing of any item etc. a copy of the same should be obtained and left over points included in visual inspection
- (j) In case the samples did not pass the visual inspection, no further tests shall be conducted and the firm may be asked to screen the offered lot.

The second visual inspection (2) shall be carried out to check whether any damage or deterioration has occurred resulting from the test/tests performed. Under visual inspection(2) mainly it should be checked that there are no cracks, loosening of components, loosening of nut/bolts, buckling of PCB, deterioration of surface finish of components PCB/peeling of copper paths, damage to protective coating, developing dry solder, components lead breakage/crack, corrosion at the root of components leads, flash over mark, sparking etc.

### 6.3.2 PERFORMANCE TEST:

These tests are carried out to check and ensure that the performance of the equipment is in order and meets the specification requirements. These tests shall be carried out at the room temperature and magnetic field not significantly different from that of earth. The operating voltage should be as per clause no. 2.2

- (a) Each dc-dc converter with rated load of 400/500 W, ammeters, voltmeters and variable voltage power supply shall be connected to measure input and output parameters under the following conditions:-

Vary the input voltage gradually from 0 to 140 V for electric locomotive and 0-85V for diesel electric locomotive and note the input and output voltage and current with lamp in circuit. Note the readings accurately when the output voltage becomes 24 V at the minimum nominal and maximum voltage. The test shall be done at minimum nominal and maximum input voltages for 3 times respectively.

Repeat the above test at no load.

- (b) Set the input voltage at nominal voltage and switch it 'ON' and 'OFF' at least 5 times from input side and 25 times from output side and see that the current limit circuit is effective and the inrush current is not more than 20 A on output side for 400 Watt and 23A for 500 Watt unit. Repeat the test at maximum input voltage as specified in clause 2.2 of this specification.
- (c) Set the input voltage at nominal voltage and a contactor across the load. Close the contactor to create the short circuit condition. Note the input, output voltage and current readings. The unit shall be kept shorted for two hours and the current limit circuit shall limit the current satisfactorily.

**6.3.2.1** The performance test shall be at nominal voltage to determine whether any deterioration has occurred due to the previous tests. This is performed during and after environmental tests to prove that the equipment under test is within its operational limits and that it has survived on environmental test.

**6.3.2.2 VOLTAGE VARIATION TEST:**

This test should carried out as per 10.2.2 (a) IEC 60571. During the test system voltage shall be as per clause no. 2.2

**6.3.2.3** A test shall be done to verify that when the display unit has a clear audio indication at the time of fault occur and keys operating condition in the working cab to attract the attention of the driver.

**6.3.3 COOLING TEST:**

Bring down the temperature of the equipment to  $0^{\circ} \pm 2$  and keep it at the temperature for 2 hours and the carried out insulation test, Dielectric test at 85% voltage of the previous test and performance test after the recovery period of 3 hrs.

**6.3.4 TEMPERATURE RISE TEST (DRY HEAT):**

The temperature of the equipment is to be raised to 75°C at the rate of 1° c at 1.5 minute and to be kept at that temperature for 6 hours. In this test equipment should be in energised condition and check the working of the system. Cool it to the room temperature (recovery period 3 hrs) and carried out insulation test, Dielectric test at 85% voltage of the previous test and performance test.

**6.3.5 TEMPERATURE RISE (DAMP HEAT):**

Damp heat test shall be done keeping the equipment in deenergised condition. It is to be ensured that the RH of the oven should be between 80 to 100% during the above test. The temperature of the equipment is to be raised from ambient to 55°C in 2 hours and kept at that temperature for 6 hours. The temperature of the equipment 55°C should be brought down to ambient (recovery period) in 3 hours. The cycle is to be repeated at least two times and carried out insulation test, Dielectric test at 85% voltage of the previous test and performance test.

**6.3.6 SUPPLY OVER VOLTAGE, SURGES AND ELECTROSTATIC DISCHARGE TEST:**

**6.3.6.1 OVER VOLTAGE TEST:**

The test shall be conducted as per IEC-60571, clause 10.2.6.1 at 200V.

1.8 times of the nominal system voltage (clause 2.2) shall be passed for two minute and the unit shall work satisfactory after the test.

**6.3.6.2 SURGE TEST:**

The test shall be conducted as per IEC-60571, clause 10.2.6.2. The surge pulse shall be 1.8 kV, 1.2/50 micro Sec

**6.3.7 TRANSIENT BURST SUSCEPTIBILITY TEST:**

This test shall be conducted as per IEC 1000 – 4 – 4. The complete system in simulated installed condition shall be put through the test as specified in . The recommended test severity level is level 4 with Direct Coupling for Power Lines & with Capacitive Coupling for Communication & Signal Lines. The EFT of defined severity shall be applied on Communication line, Analog and digital input lines as follows:

Severity for Level 4		
	Power Lines	signal Lines
Repetition rate	2.5 kHz	5 kHz
Applied voltage	4 KV	2 KV

Rise time	5 ns+/- 30%	5 ns+/- 30%
Impulse duration	50 ns +/- 30%	50 ns +/- 30%
Burst duration	15 ms +/- 20%	15 ms +/- 20%
Burst Period	300 ms +/- 20%	300 ms +/- 20%
Connections / period	Direct Coupling both positive & negative side for 60 seconds each sides	Capacitive Coupling both positive & negative side for 60 seconds each sides

During test the equipment shall be watched for malfunctioning or any erratic behaviour. Data recorded in the memory of the system during test shall also be downloaded & evaluated through Evaluation Software for the performance of the system as well as Data Recording & Downloading system.

No degradation of the system & malfunctioning should be allowed during or after the test. For more details refer IEC 1000 – 4 – 4

### 6.3.8 RADIO INTERFERENCE TEST:

#### 6.3.8.1 RFI RADIATED/RADIATED SUSCEPTIBILITY:

This test shall be conducted as per IEC 1000 – 4 – 3. The complete system in simulated installed condition shall be put in to the Radiation Chamber & desired Radiation as defined bellow shall be applied.

**Freq. Range:** 80 to 1000 MHz

**Field Strength:** 10V/m

**Amplitude Modulation:** 80% at 1kHz Sinusoidal

During test the equipment shall be watched for malfunctioning or any erratic behaviour. Data recorded in the memory of the system during test shall also be downloaded & evaluated through Evaluation Software for the performance of the system as well as Data Recording & Downloading system.

No degradation of the system & malfunctioning should be allowed during or after the test. For more details refer IEC 1000 – 4 – 3.

#### 6.3.8.2 INDUCED RF FIELD CONDUCTED/ CONDUCTED RF SUSCEPTIBILITY:

This test shall be conducted as per IEC 1000 – 4 – 6. The complete system in simulated installed condition shall be put for the test specified in IEC. The desired Radiation as defined below shall be applied on DC power in lines of Recorder cum Indicator & analog and digital input lines of equipment.

**Freq. Range:** 0.15 to 80 MHz

**Amplitude:** 10V/rms

**Modulation: 80% Amplitude Modulation**

During test the equipment shall be watched for malfunctioning or any erratic behaviour. Data recorded in the memory of the system during test shall also be downloaded & evaluated through Evaluation Software for the performance of the system as well as Data Recording & Downloading system.

No degradation of the system & malfunctioning should be allowed during or after the test. For more details refer IEC 1000 - 4 - 6.

**6.3.9 INSULATION TEST:**

Megger the electronics circuit with respect to earth and check the insulation level with 500V megger range and ensure that the insulation resistances are greater than the following minimum requirements and record the actual values obtained: The time of the meggering shall not less then 60 Sec.

- 110 V circuit and earth : 20 M ohms.
- Control and Electronics to earth : 10 M ohms.
- Screen to earth : 10 M ohms.
- Input/Output to earth : 10 M ohms.

**6.3.10 DIELECTRIC TEST:**

The test shall be conducted corresponding to 1500 V rms, 50 Hz for 1 minute applied between shorted connections and metallic supporting frame the test shall be considered as un satisfactory if either a disruption discharge of flash over occur are dielectric equipment trips before 1,minute during the test.

**6.3.11 VIBRATION AND SHOCK TEST**

**6.3.11.1 Vibration test:**

The test is to carry out as per IEC-60571, clause 10.2.11.

The complete unit together with its mounting arrangements including shock absorbing devices if provided shall be subject to the following tests:

The unit under test shall be secured in a suitable position to a vibration machine producing vibrations of sinusoidal form with adjustable amplitude and frequency. The test frequency lowers than 5Hz may be omitted. The unit shall be tests in energized condition at no load with the following parameter

- Vertical acc = 1 g at 2 h
- Longitudinal acc. = 3 g at 2 h
- Transverse acc = 2 g at 2 h

Resonance search at 10 to 100 Hz. If resonance is not met than 10 Hz at 15 min in each direction.

#### 6.3.11.2 Shock test:

The complete unit shall be subjected to a series of three successive shocks each corresponding to 50Hz at 3 g duration 2 min in all the three direction

The tests are considered to be satisfactory in case there is no resulting damage, loosening of connections/components/sub-assemblies, abnormality in operation. The unit shall be able to pass electrical performance tests after this test.

#### 6.3.12 REVERSE POLARITY TEST:

The equipment shall be tested to verify the reverse polarity protection by making the connection to reverse polarity and unit shall function normal after restoring the connection to correct polarity.

#### 6.3.13 OUTPUT SHORT CIRCUIT TEST:

The unit shall be tested by connecting a outputs, working at normal voltage short circuit shall be created at output through a switch of suitable rating and keep the unit for 2 minutes. Unit shall perform normal after the test.

#### 6.3.14 Dust test:

In case the facilities are available, it is preferable to conduct combined dust, humidity and heat test as per given parameters.

Ambient temperature	25°C +10°C
Raised upto	70°C +2°C (for 2 hrs)
humidity of	more than 80% (say 90%)
Spraying of Dust	The quantity and method of application are subject to an agreement between user and manufacturer (as per IEC-571 cl no.27)

If the facilities do not exists for combined test, the dust test alone may be conducted against combined test. After this test insulation test and Dielectric test are carried out at 85% voltage of the previous test

#### 6.3.15 Reliability Test:

The equipment shall be operated at rated resistive load of 400W for electric loco and 500W for Diesel Electric loco and nominal voltage of 110V for electric locomotive and 72 V for diesel locomotive and placed in a chamber for 100 hours. During the test the temperature in the test chamber shall be maintained at 70 deg C  $\pm$  2°C. After this test insulation test and Dielectric test are carried out at 85% voltage of the previous test.

Performance tests shall be conducted at ambient temperature on completion of 100 hour period to ensure that there is no deterioration in performance of converter

**6.3.16 Efficiency test:**

The efficiency of dc-dc converter at no load and full load shall be calculated based on readings at no load and full load. The full load efficiency shall not be less than 85 %

**6.3.17 Prototype Test Report:-**

Complete prototype test report along-with test program circuit diagram, component details, working of the circuit etc. shall be bounded in booklet form and two copies of booklet shall be submitted to RDSO for record.,

Annexure - A

Technical details of DC-DC converter to be furnished  
by the Tenderer alongwith Tender :

- |                               |   |   |
|-------------------------------|---|---|
| 1. Input voltage              | : | a) Minimum.....V<br>b) Nominal .....V<br>c) Maximum.....V   |
| 2. Input current              | : | a) At 110 V DC input...A<br>(For electric locomotives)<br>b) At 72 V DC input...A<br>(For diesel electric locomotives)                  |
| 3. Output voltage             | : | Nominal setting....V  |
| 4. Rating of each converter   | : | W   |
| 5. Dimensions                 | : | a) Length....mm<br>b) Breadth....mm<br>c) Height....mm  |
| 6. Weight of assembly         | : | ....Kg  |
| 7. Mounting arrangement       | : | .....   |
| 8. Details of each component: | : | a) Type No....<br>b) Rating with tolerance..<br>c) Junction temp. of diodes,<br>transistors, thyristors etc..<br>d) Heat sinks details. |

Annexure -B

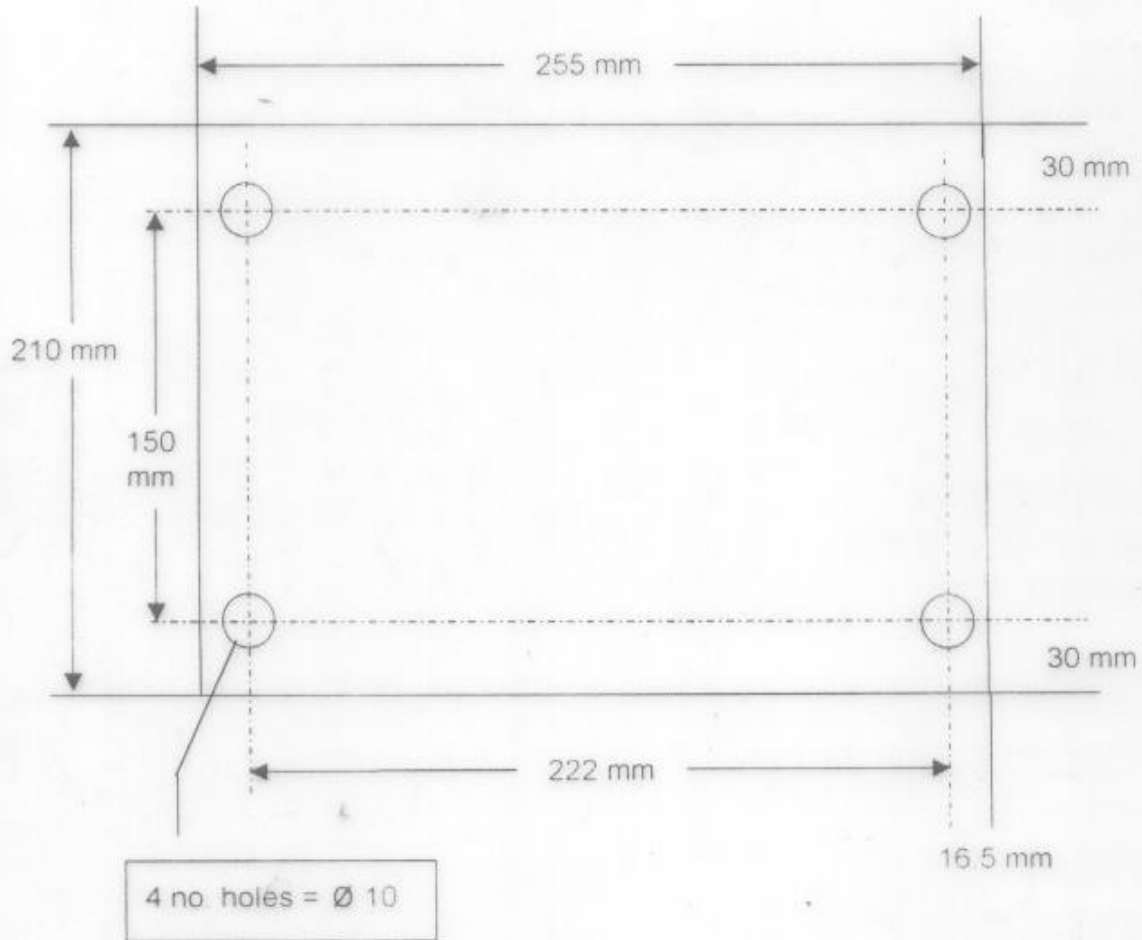

Mounting details of Dc-Dc converter

**Chief electrical Engineers:**

1. Central Railway, Mumbai, CST-400 001.
2. East Central Railway, Hazipur-844101.
3. East Coast Railway, Chandrashekharpur, Bhubaneshwar-751016.
4. Eastern Railway, Fairlie Place, Calcutta-700001.
5. North Central Railway, Hastings Road, Allahabad- 211001.
6. Northern Railway, Baroda House, New Delhi-110001.
7. South Central Railway, Secunderabad-500 071.
8. South East Central Railway, Bilaspur-495004.
9. South Eastern Railway, Garden Reach, Calcutta-700 043.
10. Southern Railway, Park Town, Chennai-600 003.
11. West-Central Railway, Jabaipur-482001.
12. Western Railway, Churchgate, Mumbai-400 020.
13. Chittaranjan Locomotive Works, Chittaranjan-713331 (WB)
14. Rail Coach Factory, PO: Hussainpur, Kapurthala-144 602(Punjab).
15. Integral Coach Factory, Perambur, Chennai-600 038.

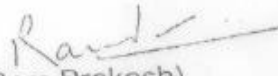
  
(Ram Prakash)  
for Director General Std/Elect

## Amendment no. 1

Sub : Amendment in the specification No. ELRS/SPEC/Dc-Dc Converter/0021 Rev-1 Sep 2004 of and DC-DC converter.

The specification No. ELRS/SPEC/Dc-Dc Converter/0021 Rev-1 Sep 2004 for Dc-Dc converter sent vide letter no. EL 6.11.1 date 22.9.04 does not include some of the parameters of diesel loco, EMU's & DMU's. The details of these parameters are given below.

Clause No	Existing	Amended
2.5	..... gray colour (code-631 of IS-5).	..... gray colour (code-631 of IS-5) for electric loco and siemens gray for diesel locos.
3.7	(i) Max. vertical acceleration - 1.0g (ii) Max. longitudinal acceleration - 3.0g (iii) Max. transverse acceleration - 2.0g	(i) Max. vertical acceleration - 3.0g (ii) Max. longitudinal acceleration - 3.0g (iii) Max. transverse acceleration - 3.0g
6.3.9	IR test -110V circuit and earth : 20 M Ohms -Control Electronics and earth : 10 M Ohms -Screen to earth : 10 M Ohms -Lamp unit to earth : 10 M Ohms	IR test - Control circuit and earth : 20 M Ohms - Electronics and earth : 20 M Ohms -Screen to earth : 20 M Ohms -Lamp unit to earth : 20 M Ohms
6.3.11.1	Vertical acc. = 1.0g at 2h Longitudinal acc. = 3.0g at 2h Transverse acc. = 2.0g at 2h	Vertical acc. = 3.0g at 8 hours Longitudinal acc. = 3.0g at 8 hours Transverse acc. = 3.0g at 8 hours

These amendments should be read along with above specifications

Copy to: Dir/MP

  
(Ram Prakash)  
For DG/Electrical

Distribution: As per Attached list