



CORPORATE STANDARD

AA0230201

Rev. No. 02

PAGE 1 of 31

ISO SYSTEM OF LIMITS AND FITS (BASES OF TOLERANCES, DEVIATIONS AND FITS)

1.0 SCOPE

This corporate standard gives the bases of the ISO system of limits and fits together with the calculated values of the standard tolerances and fundamental deviations. These values shall be taken as authoritative for the application of the system (see also clause A.1)

This corporate standard also gives terms and definitions together with associated symbols.

1.1 This corporate standard is based on IS: 919 Part 1-1993/Reaffirmed 2008 (ISO 286-1)

1.2 The hole basis system shall only be used in BHEL.

2.0 FIELD OF APPLICATION

The ISO system of limits and fits provides a system of tolerances and deviations suitable for plain work pieces.

For simplicity and also because of the importance of cylindrical work pieces of circular section, only these are referred to explicitly. It should be clearly understood, however, that the tolerances and deviations given in this standard equally apply to work pieces of other than circular section.

In particular, the general term "hole" or "shaft" can be taken as referring to the space contained by (or containing) the two parallel faces (or tangent planes) of any work piece, such as the width of a slot or the thickness of a key.

The system also provides for fits between mating cylindrical features or fits between work pieces having features with parallel faces, such as the fit between a key and keyway, etc.

NOTE - It should be noted that the system is not intended to provide fits for work piece with features having other than simple geometric forms.

For the purposes of this Corporate Standard, a simple geometric form consists of a cylindrical surface area or two parallel planes.

3.0 REFERRED STANDARDS

Note - See also clause 10.

ISO 1 Standard reference temperature for industrial length measurements.

AA0230203 (ISO 286) ISO system of limits and fits - part 2: Tables of standard tolerance grades and limit deviations for holes and shafts.

ISO/R 1938, ISO system of limits and fits - Inspection of plain work pieces¹⁾

ISO 8015 IS: 12160 Technical drawings - Fundamental tolerancing principle.

Revisions: As per Clause 18.7 of 18th MOM of PGC-DOP+BES

APPROVED:
PROCEDURAL GUIDELINES COMMITTEE -
PGC (DOP+BES)

Rev. No. 02	Amd. No.	Reaffirmed	Prepared	Issued	Dt. of 1 st Issue
Dt: 02-01-2014	Dt:	Year: 2015	HEEP, Haridwar	Corp. R&D	01-03-1977

COPYRIGHT AND CONFIDENTIAL
 The information on this document is the property of BHARAT HEAVY ELECTRICALS LIMITED.
 It must not be used directly or indirectly in any way detrimental to the interests of the company.

10/3/11
 CS-0229

AA0230201

Rev. No. 02

PAGE 2 of 31

CORPORATE STANDARD



4.0 TERMS AND DEFINITIONS

For the purposes for this Standard, the following terms and definitions apply. It should be noted, however, that some of the terms are defined in a more restricted sense than in common usage.

4.1 Shaft

A term used, according to convention, to describe an external feature of a work piece, including features which are not cylindrical (see also clause 2).

4.1.1 Basic shaft

Shaft chosen as a basis for a shaft-basis system of fits (see also 4.11.1)

For the purposes of the ISO system of limits and fits, a shaft the upper deviation of which is zero.

4.2 Hole

A term used, according to convention, to describe an internal feature of a work piece, including features which are not cylindrical (see also clause 2)

4.2.1 Basic hole

Hole chosen as a basis for a hole-basis system of fits (see also 4.11.2)

For the purposes of the ISO system of limits and fits, a hole the lower deviation of which is zero.

4.3 Size

A number expressing, in a particular unit, the numerical value of a linear dimension.

4.3.1 Basic Size; nominal size

The size from which the limits of size are derived by the application of the upper and lower deviations (see figure 1).

NOTE – The basic size can be a whole number or a decimal number, e.g 32; 15; 8,75; 0,5; etc.

4.3.2 Actual size

- The size of a feature, obtained by measurement.

4.3.2.1 Actual local size

Any individual distance at any cross section of a feature, i.e. any size measured between any two opposite points.

4.3.3 Limits of size

The two extreme permissible sizes of a feature, between which the actual size should lie, the limits of size being included.

4.3.3.1 Maximum limit of size

The greatest permissible size of a feature (see figure 1)

4.3.3.2 Minimum limit of size

The smallest permissible size of a feature (see figure 1)

10/01/15
CS-0229



CORPORATE STANDARD

AA0230201

Rev. No. 02

PAGE 3 of 31

4.4 Limit System

A system of standardized tolerances and deviations.

4.5 Zero line

In a graphical representation of limits and fits, the straight line, representing the basic size, to which the deviations and tolerances are referred (see figure 1),

According to convention, the zero line is drawn horizontally, with positive deviations shown above and negative Deviations below (see figure 2).

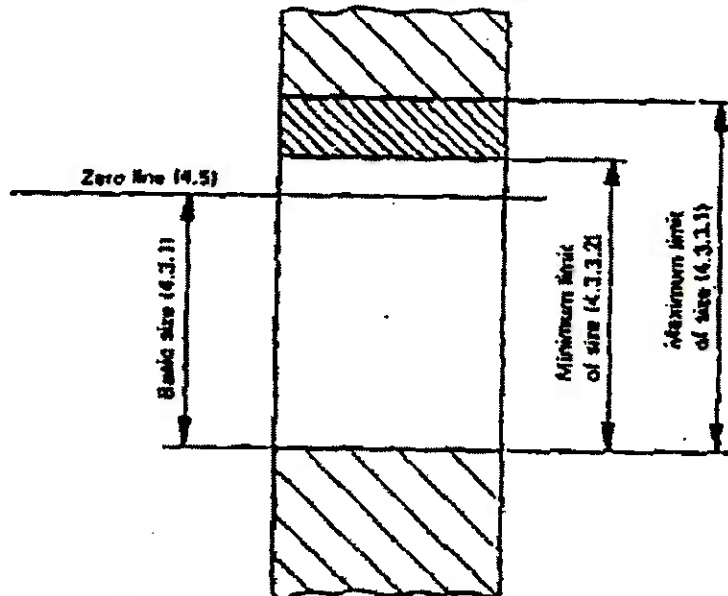

Figure 1 – Basic size, and maximum and minimum limits of size

4.6 Deviation

The algebraic difference between a size (actual size, limit of size, etc) and the corresponding basic size.

Note:- Symbols for shaft deviations are lower case letters (*es*, *ei*) and symbols for hole deviations are upper case Letters (*ES*, *EI*) (see figure 2).

4.6.1 Limit deviations

Upper deviation and lower deviation.

4.6.1.1 Upper deviation (ES, es)

The algebraic difference between the maximum limit of size and the corresponding basic size (see figure 2).

4.6.1.2 Lower deviation (ES, es)

The algebraic difference between the minimum limit of size and the corresponding basic size (see figure 2).

4.6.2 Fundamental deviation

For the purpose of the ISO system of limits and fits, that deviation which defines the position of the tolerance zone, in relation to the zero line (see figure 2).

NOTE: This may be either the upper or lower deviation, but, according to convention, the fundamental deviation is the one nearest the zero line.

es-02-29 10/3/15

CORPORATE STANDARD



4.7 Size tolerance

The difference between the maximum limit of size and the minimum limit of size i.e. the difference between the upper deviation and the lower deviation.

NOTE: The tolerance is an absolute value without sign.

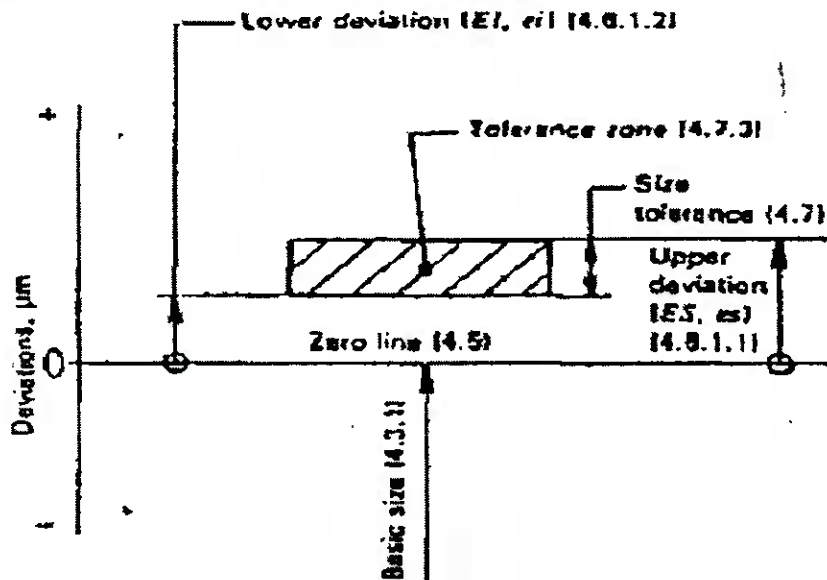

Figure 2 – Conventional representation of a tolerance zone

4.7.1 Standard tolerance (IT)

For the purpose of the ISO system of limits and fits, any tolerance belonging to this system.

NOTE: The letters of the symbol IT stand for “International Tolerance” grade.

4.7.2 Standard tolerance grades

For the purpose of the ISO system of limits and fits, a group of tolerances (e.g. IT7), considered as corresponding to the same level of accuracy for all basic sizes.

4.7.3 Tolerance class

In a graphical representation of tolerances, the zone, contained between two lines representing the maximum and minimum limits of size, defined by the magnitude of the tolerance and its position relative to the zero line (see figure 2).

4.7.4 Tolerance class

The term used for a combination of fundamental deviation and a tolerance grade, e.g. h9, D13 etc.

4.7.5 Standard tolerance factor (i, I)

For the purposes of the ISO system of limits and fits, a factor which is a function of the basic size, and which is used as a basis for the determination of the standard tolerances of the system.

Notes

A.1 The standard tolerance factor *i* is applied to basic sizes less than or equal to 500 mm.

CSO 227 10/3/15



CORPORATE STANDARD

AA0230201

Rev. No. 02

PAGE 5 of 31

A.2 The standard tolerance factor I is applied to basic sizes greater than 500 mm.

4.8 Clearance

The positive difference between the sizes of the hole and the shaft, before assembly, when the diameter of the shaft is smaller than the diameter of the hole (see figure 3).

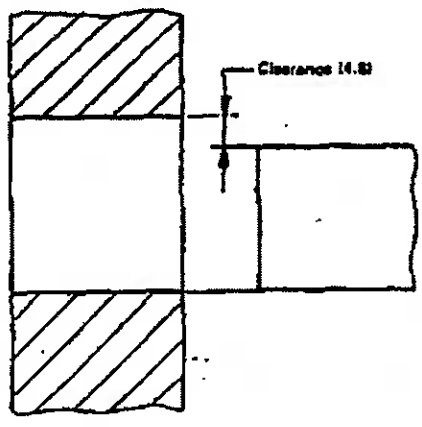

Figure 3 - Clearance

4.8.1 Minimum Clearance

In a clearance fit, the positive difference between the minimum limit of size of the hole and the maximum limit of size of the shaft (see figure 4).

4.8.2 Maximum Clearance

in a clearance or transition fit, the positive difference between the maximum limit of size of the hole and the minimum limit of size of the shaft (see figures 4 and 5).

4.9 Interference

The negative difference between the sizes of the hole and the shaft, before assembly, when the diameter of the shaft is larger than the diameter of the hole (see figure 6).

4.9.1 Minimum Interference

In an interference fit, the negative difference, before assembly, between the maximum limit of size of the hole and the minimum limit of size of the shaft (see figure 7).

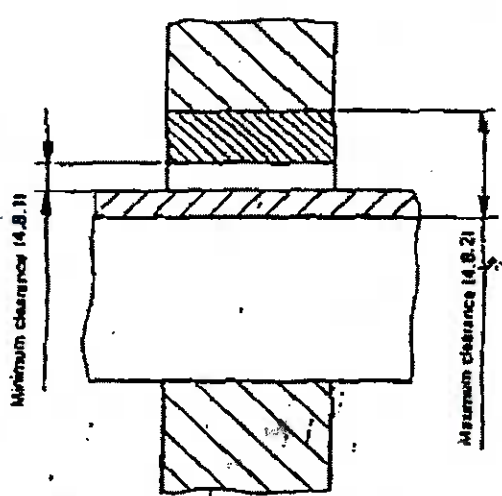

Figure 4 - Clearance fit

CS-0279 10/3/15

CORPORATE STANDARD

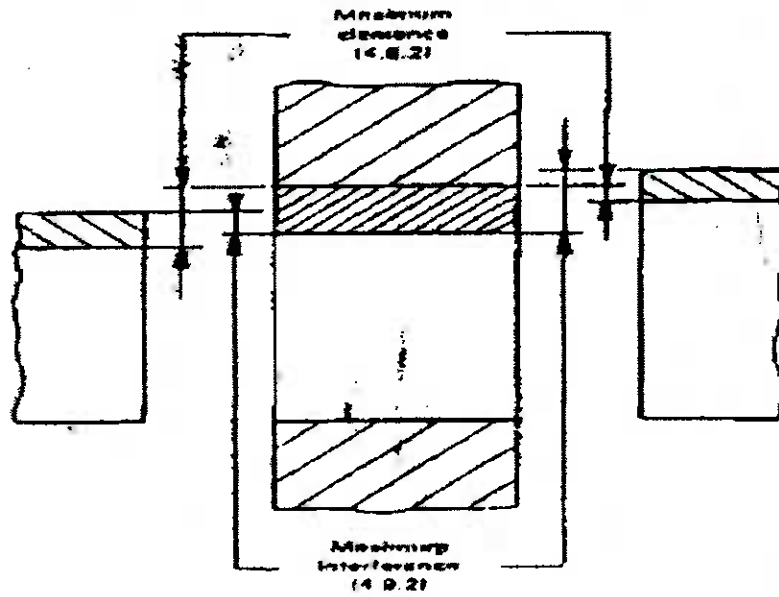

Figure 5 - Transition fit

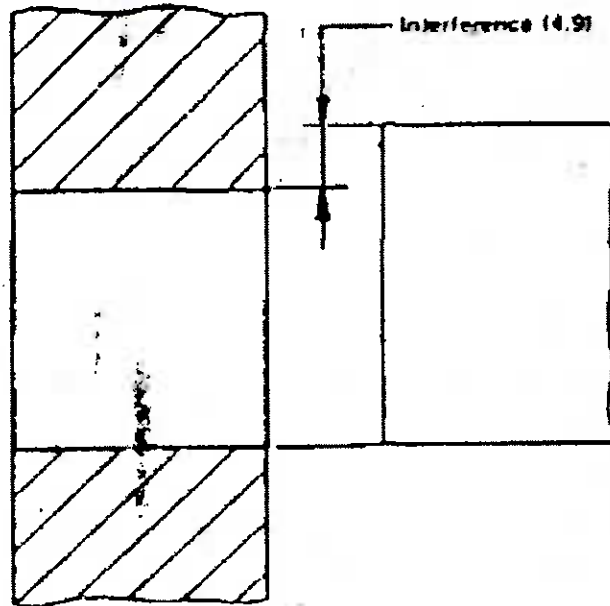

Figure 6 - Interference

4.9.2 Maximum Interference

In an interference or transition fit, the negative difference, before assembly, between the minimum limit of size of the hole and the maximum limit of size of the shaft (see figures 5 and 7).

4.10 Fit

The relationship resulting from the difference, before assembly, between the sizes of the two features (the hole and the shaft) which are to be assembled.

NOTE: The two mating parts of a fit have a common basic size.

CS-0229 10/3/11



CORPORATE STANDARD

AA0230201

Rev. No. 02

PAGE 7 of 31

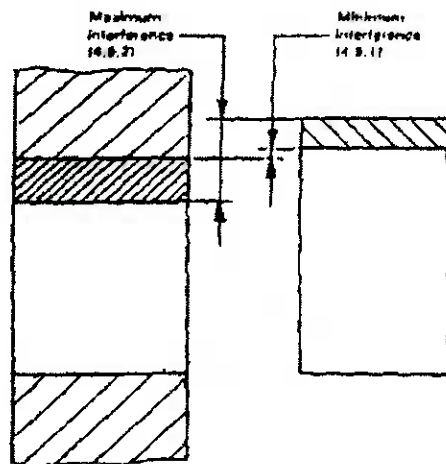

Figure 7 - Interference fit

4.10.1 Clearance fit

A fit that always provides a clearance between the hole and shaft when assembled, i.e., the minimum size of the hole is either greater than or, in the extreme case, equal to the maximum size of the shaft (see Figure 8).

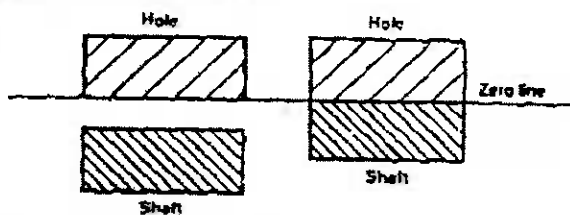

Figure 8 - Schematic representation of clearance fit

4.10.2 Interference fit

A fit which everywhere provides an interference between the hole and shaft when assembled, i.e. the maximum size of the hole is either smaller than or, in the extreme case, equal to the minimum size of the shaft (see figure 9).

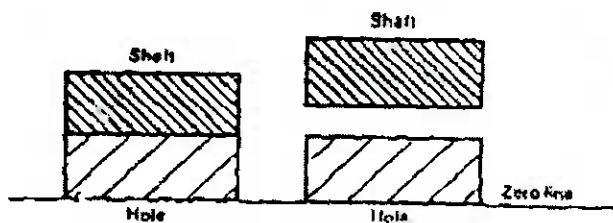

Figure 9 - Schematic representation of interference fits

4.10.3 Transition fit

A fit which may provide either a tolerance or an interference between the hole and shaft when assembled, depending on the actual sizes of the hole and shaft, i.e. the tolerance zones of the hole and the shaft overlap completely or in part (see figure 10).

CS-0229 10/3/15

CORPORATE STANDARD

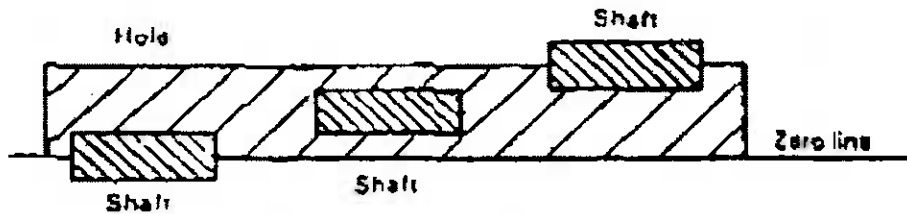

Figure 10 – Schematic representation of transition fits

4.10.4 Variation of a fit

The arithmetic sum of the tolerances of the two features comprising the fit.

Note: The variation of a fit is an absolute value without sign.

4.11 Fit system

A system of fits comprising shafts and holes belonging to a limit system.

4.11.1 Shaft basis system of fits

A system of fits in which the required clearances or interferences are obtained by associating holes of various tolerance classes with shafts of a single tolerance class.

For the purposes of the ISO system of limits and fits, a system of fits in which the maximum limit of size of the shaft is identical to the basic size i.e. the upper deviation is zero (see figure 11)

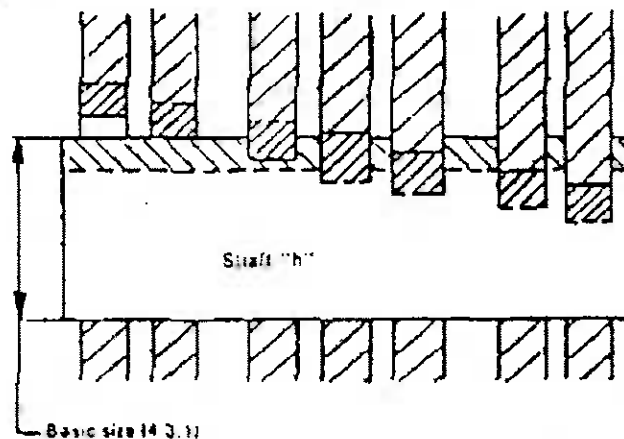

Figure 11 - Shaft-basis system of fits

NOTES:

- 1) The horizontal continuous line represent the fundamental deviations for holes or shafts.
- 2) The dashed lines represent the other limits and show the possibility of different combinations between holes and shafts, related to their grade of tolerance (e.g G7/ h4, H6/h4, M5/h4).

4.11.2 Hole - basis system of fits

A system of fits in which the required clearances or interferences are obtained by associating shaft of various tolerance classes with holes of a single tolerance class.

CS-0229 10/3/15



CORPORATE STANDARD

AA0230201

Rev. No. 02

PAGE 9 of 31

For the purposes of the ISO system of limits and fits, a system of fits in which the minimum limit of size of the hole is identical to the basic size. i.e. the lower deviation is zero (see figure 12).

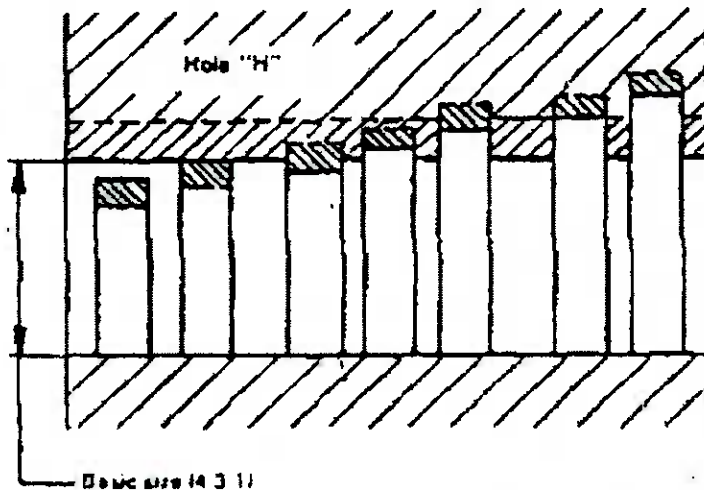

Figure 12 - Hole-basis system of fits

NOTES:

- 1) The horizontal continuous lines represent the fundamental deviations for holes or shafts.
- 2) The dashed lines represent the other limits and show the possibility of different combinations between holes and shafts, related to their grade of tolerance (e.g. H6/h6, H6/s5, H6/p4).

4.12 Maximum material limit (MML)

The designation applied to that of the two limits of size which corresponds to the maximum material size for the feature i.e.

A.1 The maximum (upper) limit of size for an external feature (shaft)

A.2 The minimum (lower) limit of size for an internal feature (hole)

Note - Previously called "GO limit"

4.13 Least material limit (LML)

The designation applied to that of the two limits of size which corresponds to the minimum material size for the feature. i.e.

- 1) The minimum (Lower) limit of size for an external feature (shaft)
- 2) The maximum (Upper) limit of size for an internal feature (hole)

Note - Previously called "NOT GO limit"

CS-0229 10/3/15

AA0230201
Rev. No. 02
PAGE 10 of 31

CORPORATE STANDARD



5.0 SYMBOLS, DESIGNATION AND INTERPRETATION OF TOLERANCES, DEVIATIONS AND FITS

5.1 Symbols

5.1.1 Standard tolerance grades

The standard tolerance grades are designated by the letters IT followed by a number, e.g. IT7. When tolerance grade is associated with (a) letter(s) representing a fundamental deviation to form a tolerance class, the letters IT are omitted e.g.h7.

NOTE – The ISO system provides for a total of 20 standard tolerance grades of which grades IT1 to IT18 are in general use and given in the main body of the standard. Grades IT0 and IT01, which are not in general use, are given in annex A for information purposes.

5.1.2 Deviations

5.1.2.1 Position of tolerance Zone

The position of the tolerance zone with respect to the zero line, which is a function of the basic size, is designated by (an) upper case letter(s) for holes (A...ZC) or (a) lower case letter(s) for shafts (a...zc) (see figures 13 and 14).

NOTE – To avoid confusion, the following letters are not used:

I, l; L, l; O, o; Q, q; W, w

5.1.2.2 Upper deviations

The upper deviations are designated by the letters “ES” for holes and the letters “es” for shafts.

5.1.2.3 Lower Deviations

The lower deviations are designated by the letters “EI” for holes and the letters “ei” shafts.

5.2 Designation

5.2.1 Tolerance class

- A tolerance class shall be designated by the letter(s) representing the fundamental deviation followed by the number representing the standard tolerance grade.

Examples:

H7 (holes)

h7 (shafts)

5.2.2 Toleranced size

A tolerance size shall be designated by the basic size followed by the designation of the required tolerance class, or the explicit deviations.

Example:

32H7

80js15

100g6

100 $\begin{matrix} -0.012 \\ -0.034 \end{matrix}$

CS-0209 10/3/18



CORPORATE STANDARD

AA0230201

Rev. No. 02

PAGE 11 of 31

ATTENTION – In order to distinguish between holes and shafts when transmitting information on equipment with limited character sets, such as telex, the designation shall be prefixed by the following letters:

- 1) H or h holes;
- 2) S or s for shafts

Examples:

50H5 becomes H50H5 or h50h5

50h6 becomes S50H6 or s50h6

This method of designation shall not be used on drawings.

5.2.3 Fit

A fit requirement between mating features shall be designated by

- 1) The common basic size;
- 2) The tolerance class symbol for the hole;
- 3) The tolerance class symbol for the shaft.

Examples:

52H7/g6 or 52 $\frac{H7}{g6}$

ATTENTION: In order to distinguish between the hole and the shaft when transmitting information on equipment with limited character sets, such as telex, the designation shall be prefixed by the following letters:

- a) H or h for holes;
- b) S or s for shafts;
- c) and the basic size repeated

Examples:

52H7/g6 becomes H52H7/S52G6 or h52h7/s52g6

This method of designation shall not be used on drawings.

5.3 Interpretation of a tolerance size

5.3.1 Tolerance indication in accordance with ISO 8015

The tolerances for work pieces manufactured to drawings marked with the notation, Tolerancing ISO 8015, shall be interpreted as indicated in 5.3.1.1 and 5.3.1.2

5/10/01
622 050

CORPORATE STANDARD

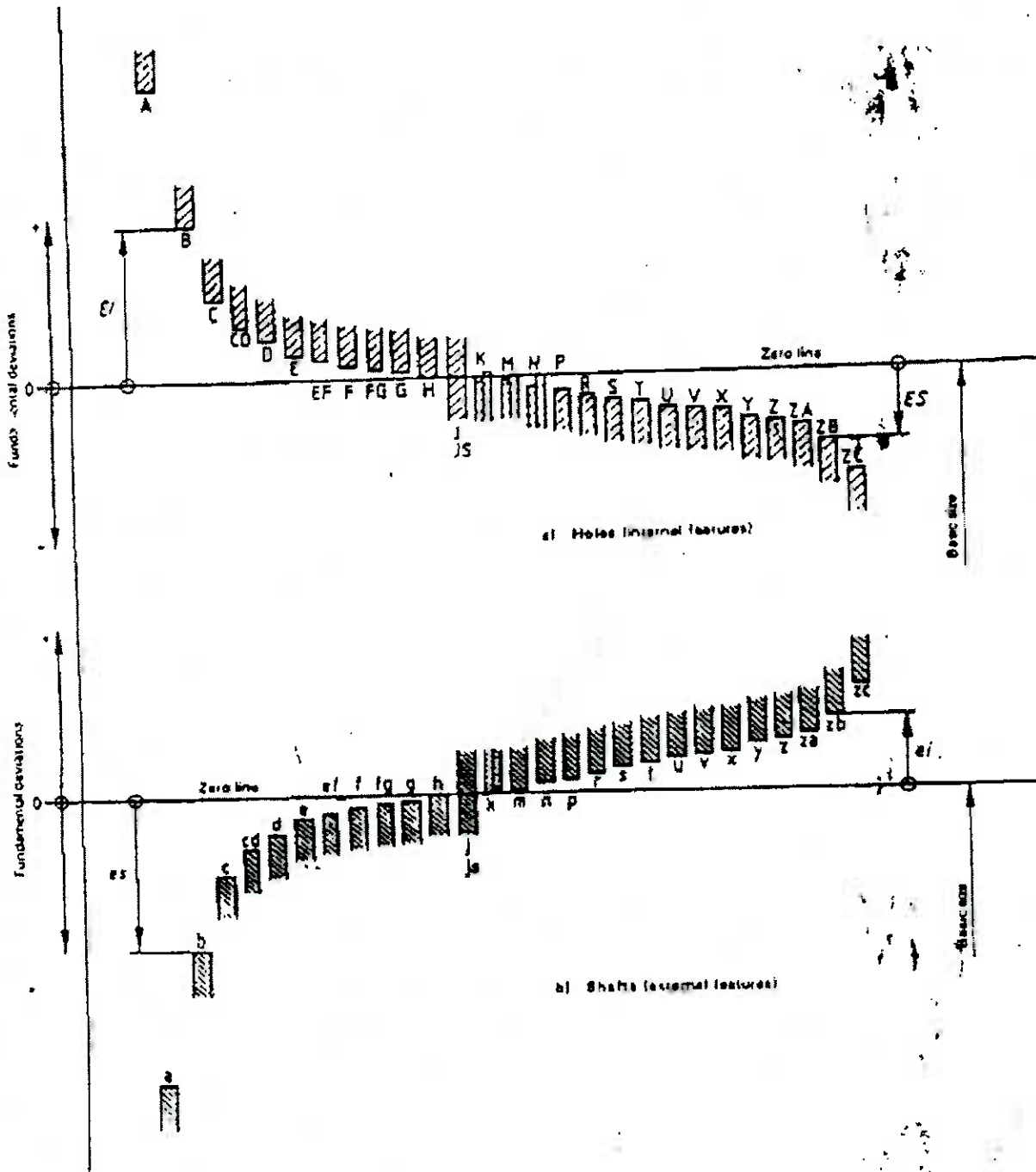

NOTES:

- 1) According to convention, the fundamental deviation is the one defining the nearest limit to the zero line.
- 2) For details concerning fundamental deviations for J/j, K/k, M/m and N/n, see figure 14.

Figure 13 - Schematic representation of the position of fundamental deviations

CS 0229 10/3/13



CORPORATE STANDARD

AA0230201

Rev. No. 02

PAGE 13 of 31

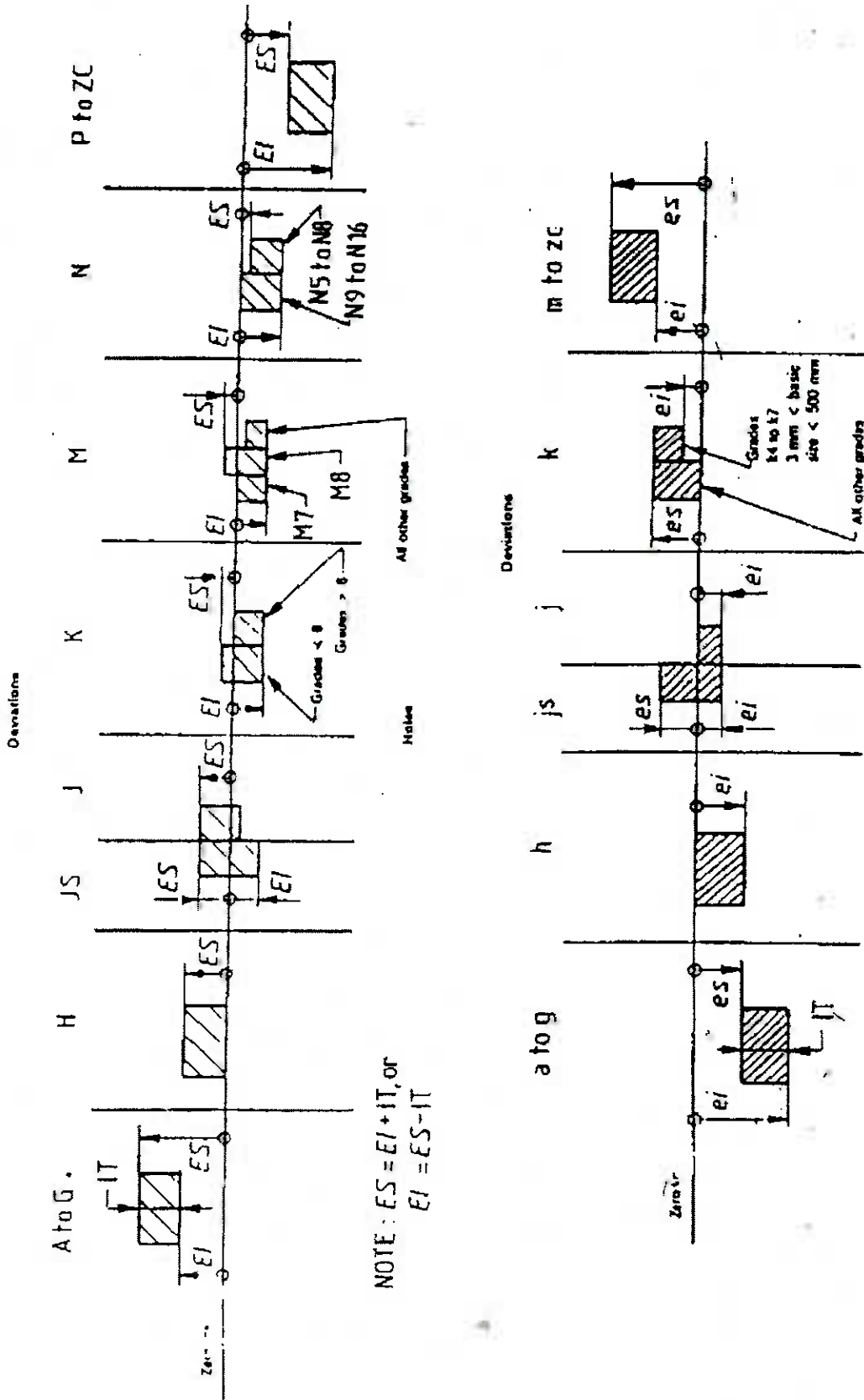

Figure 14 -- Deviations for shafts and holes

CS-0229 10/3/15

AA0230201

Rev. No. 02

PAGE 14 of 31

CORPORATE STANDARD



5.3.1.1 Linear size tolerances

A linear size tolerance controls only the actual local sizes (two point measurements) of a feature, but not its form deviations (for example circularity and straightness deviations of a cylindrical feature or flatness deviations of parallel surfaces). There is no control of the geometrical interrelationship of individual features by the size tolerances. (For further information, see ISO/R 1938 and ISO 8015).

5.3.1.2 Envelope requirement

Single features, whether a cylinder, or established by two parallel planes, having the function of a fit between mating parts, are indicated on the drawing by the symbol Ⓢ in addition to the dimension and tolerance. This indicates a mutual dependence of size and form which requires that the envelope of perfect form for the feature at maximum material size shall not be violated. (For further information, see ISO/R 1938 and ISO 8015).

NOTE - Some national standards (which should be referred to on the drawing) specify that the envelope requirement for single features is the norm and therefore this is not indicated separately on the drawing.

5.3.2 Tolerance indication not in accordance with ISO 8015

The tolerances for work pieces manufactured to drawings which do not have the notation, Tolerancing ISO 8015, shall be interpreted in the following ways within the stipulated length.

B.1 For holes

The diameter of the largest perfect imaginary cylinder, which can be inscribed within the hole so that it just contacts the highest points of the surface, should not be smaller than the maximum material limit of size. The maximum diameter at any position in the hole shall not exceed the least material limit of size.

B.2 For shafts

The diameter of the smallest perfect imaginary cylinder, which can be circumscribed about the shaft so that it just contacts the highest points of the surface, should not be larger than the maximum material limit of size. The minimum diameter at any position on the shaft shall be not less than the least material limit of size.

The interpretations given in a) and b) mean that if a work piece is everywhere at its maximum material limit, that work piece should be perfectly round and straight, i.e. a perfect cylinder.

Unless otherwise specified, and subject to the above requirements, departures from a perfect cylinder may reach the full value of the diameter tolerance specified. For further information, see ISO/R 1938.

NOTE - In special cases, the maximum form deviations permitted by the interpretations given in a) and b) may be too large to allow satisfactory functioning of the assembled parts: in such cases, separate tolerances should be given for the form, e.g. separate tolerances on circularity and / or straightness (see AA0230415)

10/02/15
C.S.-0229



CORPORATE STANDARD

AA0230201

Rev. No. 02

PAGE 15 of 31

6.0 Graphical Representation:

The major terms and definitions given in clause 4 are illustrated in figure 15.

In practice, a schematic diagram such as that shown in figure 16 is used for simplicity. In this diagram, the axis of the work pieces, which is not shown in the figure, according to convention always lies below the diagram.

In the example illustrated, the two deviations of the hole are positive and those of the shaft are negative.

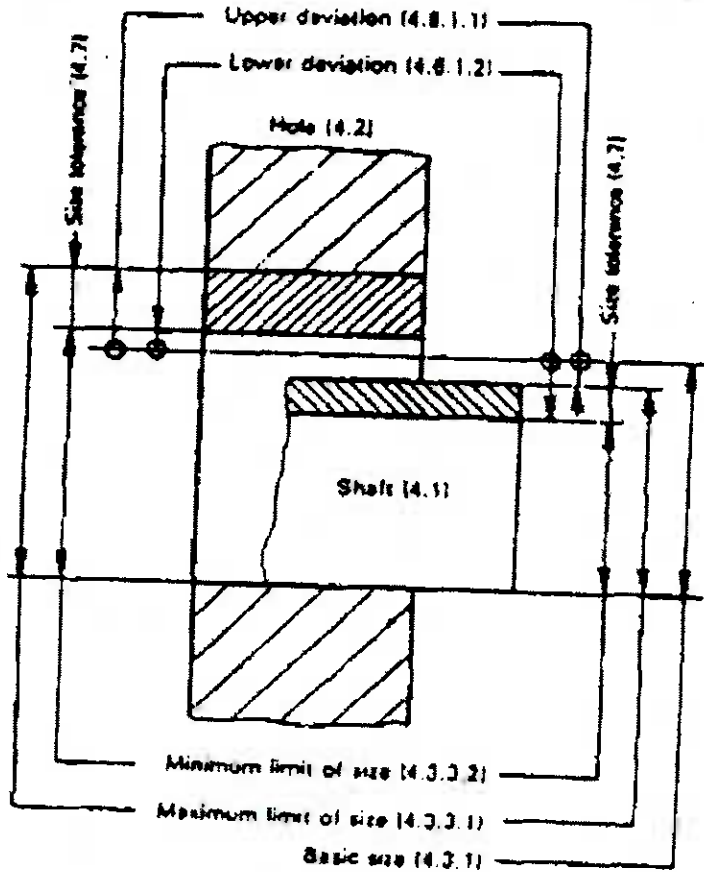

Figure 15 – Graphical Representation

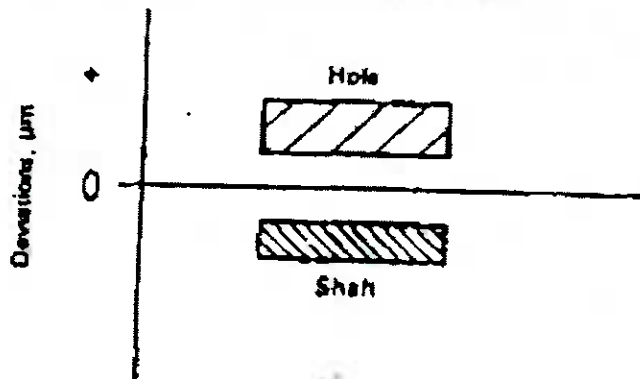

Figure 16 – Simplified schematic diagram

CS-0229 10/2/15



7.0 REFERENCE TEMPERATURE

The temperature at which the dimensions of the ISO system of limits and fits are specified is 20° C (see ISO 1)

8.0 STANDARD TOLERANCES FOR BASIC SIZES UP TO 3150 mm

8.1 Basis of the system

The bases for calculating the standard tolerances are given in annex A.

8.2 Values of standard tolerance grades (IT)

Values of standard tolerance grades IT1 to IT18 inclusive are given in table 1. These values are to be taken as authoritative for the application of the system.

NOTE - Values for standard tolerance grades IT0 and IT01 are given in annex A.

9.0 FUNDAMENTAL DEVIATIONS FOR BASIC SIZES UP TO 3150 mm

9.1 Fundamental deviations for shafts [except deviation is (see 9.3)]

The fundamental deviations for shafts and their respective sign (+ or -) are shown in figure 17. Values for the fundamental deviations are given in table 2.

The Upper deviation (es) and lower deviation (ei) are established from the fundamental deviation and the standard tolerance grade (IT) as shown in figure 17.

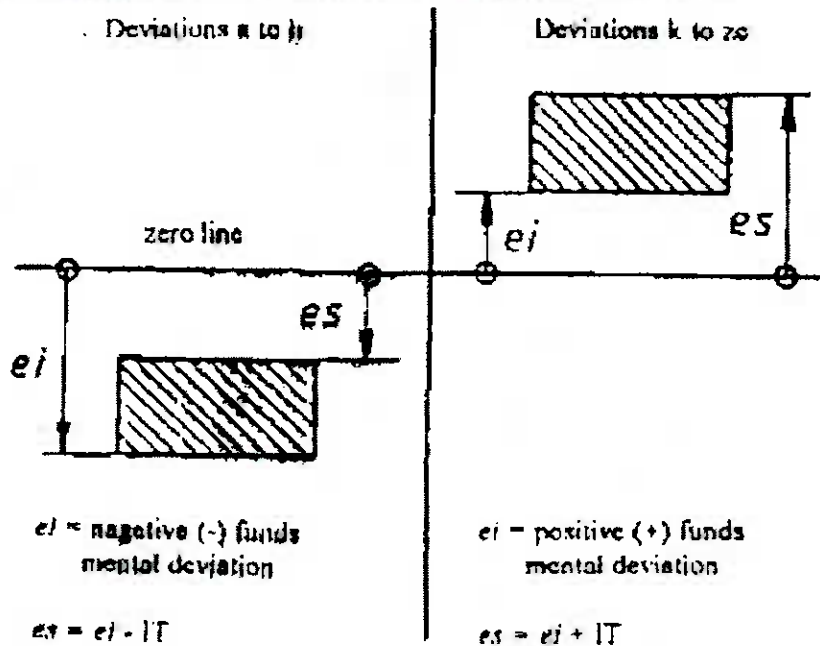

Figure 17 - Deviations for shafts

CS-0229 10/3/15



CORPORATE STANDARD

AA0230201

Rev. No. 02

PAGE 17 of 31

9.2 Fundamental deviation for holes [except deviation JS (see 9.3)]

The fundamental deviations for holes and their respective sign (+ or -) are shown in figure 18. Values for the fundamental deviations are given in table 3.

The upper deviation (ES) and lower deviation (EI) are established from the fundamental deviation and the standard tolerance grade (IT) as shown in figure 18.

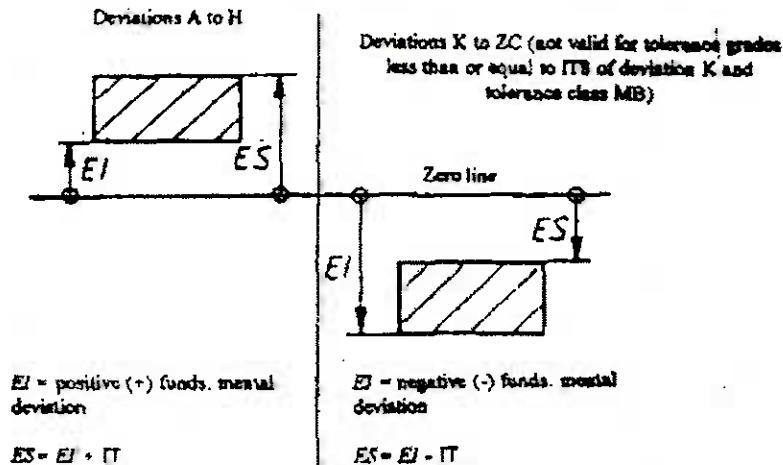

Figure 18 – Deviations for holes

9.3 Fundamental deviation js and JS (see figure 19)

The information given in 9.1 and 9.2 does not apply to fundamental deviations js and JS which are a symmetrical distribution of the standard tolerance grade about the zero line, i.e. for js:

$$es = ei = \frac{IT}{2}$$

and for JS:

$$ES = EI = \frac{IT}{2}$$

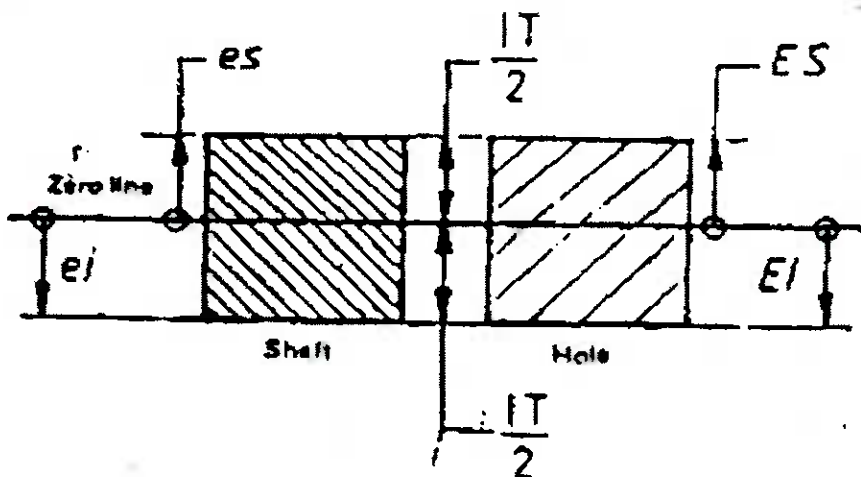

Figure 19 – Deviations js and JS

C.S. 0229 10/3/15

CORPORATE STANDARD



9.4 Fundamental deviations j and J

The information given in 9.1 to 9.3 does not apply to fundamental deviations j and J, which are, for the most part, asymmetrical distributions of the standard tolerance grade about the zero line (see AA0230206 tables 8 and 24).

Table 1 - Numerical values of standard tolerance grades IT for basic sizes up to 3150 mm¹⁾

Basic Size mm		Standard tolerance grades																	
		IT1 ²⁾	IT2 ²⁾	IT3 ²⁾	IT4 ²⁾	IT5 ²⁾	IT6	IT7	IT8	IT9	IT10	IT11	IT12	IT13	IT14 ²⁾	IT15 ²⁾	IT16 ²⁾	IT17 ²⁾	IT18 ²⁾
Above	Upto and including	Tolerances																	
		µm									mm								
-	3 ²⁾	0.8	1.2	2	3	4	5	10	14	25	40	60	0.1	0.14	0.25	0.4	0.6	1	1.4
3	6	1	1.5	2.5	4	5	8	12	18	30	48	75	0.12	0.18	0.3	0.48	0.75	1.2	1.8
6	10	1	1.5	2.5	4	6	9	15	22	36	58	90	0.15	0.22	0.36	0.58	0.9	1.5	2.2
10	18	1.2	2	3	5	8	11	18	27	43	70	110	0.18	0.27	0.43	0.7	1.1	1.8	2.7
18	30	1.5	2.5	4	6	9	13	21	33	52	84	130	0.21	0.33	0.52	0.84	1.3	2.1	3.3
30	50	1.5	2.5	4	7	11	16	25	39	62	100	160	0.25	0.39	0.62	1	1.6	2.5	3.9
50	80	2	3	5	8	13	19	30	46	74	120	190	0.3	0.46	0.74	1.2	1.9	3	4.6
80	120	2.5	4	6	10	15	22	35	54	87	140	220	0.35	0.54	0.87	1.4	2.2	3.5	5.4
120	180	3.5	5	8	12	18	25	40	63	100	160	250	0.4	0.63	1	1.6	2.5	4	6.3
180	250	4.5	7	10	14	20	29	46	72	115	185	290	0.46	0.72	1.15	1.85	2.9	4.6	7.2
250	315	6	8	12	16	23	32	52	81	130	210	320	0.52	0.81	1.3	2.1	3.2	5.2	8.1
315	400	7	9	13	18	25	36	57	89	140	230	360	0.57	0.89	1.4	2.3	3.6	5.7	8.9
400	500	8	10	15	20	27	40	63	97	155	250	400	0.63	0.97	1.55	2.5	4	6.3	9.7
500	630 ²⁾	9	11	16	22	32	44	70	110	175	280	440	0.7	1.1	1.75	2.8	4.4	7	11
630	800 ²⁾	10	13	18	25	36	50	80	125	200	320	500	0.8	1.25	2	3.2	5	8	12.5
800	1000 ²⁾	11	15	21	28	40	56	90	140	230	360	560	0.9	1.4	2.3	3.6	5.6	9	14
1000	1250 ²⁾	13	18	24	33	47	66	105	165	260	420	660	1.05	1.65	2.6	4.2	6.6	10.5	16.5
1250	1600 ²⁾	15	21	29	39	55	78	125	195	310	500	780	1.25	1.95	3.1	5	7.8	12.5	19.5
1600	2000 ²⁾	18	25	35	46	65	92	150	230	370	600	920	1.5	2.3	3.7	6	9.2	15	23
2000	2500 ²⁾	22	30	41	55	78	110	175	280	440	700	1100	1.75	2.8	4.4	7	11	17.5	28
2500	3150 ²⁾	26	36	50	68	96	135	210	330	540	860	1350	2.1	3.3	5.4	8.6	13.5	21	33

- B.3 Values for standard tolerance grades IT01 and IT0 for basic sizes less than or equal to 500 mm are given in annex A, table 5.
- B.4 Values for standard tolerance grades IT1 to IT5 (incl.) for basic sizes over 500 mm are included for experimental use.
- B.5 Standard tolerance grades IT14 to IT18 (incl.) shall not be used for basic sizes less than or equal to 1 mm.

CS-0229 10/3/15

CS-0229 10/3/18

CORPORATE STANDARD



Table-3 Numerical values of the fundamental deviations of holes

Fundamental deviation values in micrometres

Basic size mm	Fundamental deviation values																			Fundamental deviation values in micrometres																										
	Lower deviation EI											Upper deviation ES								Values for Δ																										
	All standard tolerance grades											Standard tolerance grades above IT7								Standard tolerance grades																										
Allow	Up to and including	AS	BS	C	CD	D	E	ES	F	FG	G	H	JS	IT6	IT7	IT8	Up to IT9 (incl.)	Above IT8	Up to IT9 (incl.)	Above IT8	Up to IT9 (incl.)	Above IT8	Up to IT7 (incl.)	P	R	S	T	U	V	X	Y	Z	ZA	ZB	ZC	IT3	IT4	IT5	IT6	IT7	IT8					
3	5	+270	+140	+70	+35	+20	+14	110	16	+4	+2	0	-1.2	+4	+6	0	0	-2	2	-4	-4	6	-10	-14	-18	-23	-28	-34	-41	-47	-54	-61	-68	-75	-82	-90	0	0	0	0	0	0				
6	10	+270	+140	+70	+35	+20	+14	110	16	+4	+2	0	+5	+8	+10	+12	+14	+16	+18	+20	+22	12	-12	-15	-19	-23	-28	-34	-41	-47	-54	-61	-68	-75	-82	-90	0	0	0	0	0	0				
10	14	+280	+150	+80	55	+40	+25	+15	+13	+8	+5	0	+5	+8	+12	+14	+16	+18	+20	+22	+24	15	-15	-19	-23	-28	-34	-41	-47	-54	-61	-68	-75	-82	-90	0	0	0	0	0	0					
14	18	+290	+150	+95	55	+50	+30	+16	+10	+6	0	0	+6	+10	+15	+18	+20	+22	+24	+26	+28	15	-18	-23	-28	-34	-41	-47	-54	-61	-68	-75	-82	-90	0	0	0	0	0	0						
18	24	+300	+160	+110	55	+65	+40	+20	+10	+7	0	0	+8	+12	+18	+22	+24	+26	+28	+30	+32	15	-22	-28	-35	-41	-48	-55	-64	-75	-88	-100	-118	-140	-160	-188	0	0	0	0	0	0				
24	30	+320	+180	+120	55	+80	+50	+25	+10	+9	0	0	+10	+14	+22	+28	+32	+36	+40	+44	+48	15	-26	-34	-41	-48	-55	-64	-75	-88	-100	-118	-140	-160	-188	0	0	0	0	0	0					
30	40	+340	+200	+140	55	+100	+60	+30	+10	+10	0	0	+11	+16	+26	+32	+36	+40	+44	+48	+52	15	-32	-41	-50	-60	-71	-83	-97	-114	-134	-160	-192	-230	-270	0	0	0	0	0	0					
40	50	+360	+220	+150	55	+120	+72	+36	+12	+12	0	0	+12	+18	+30	+36	+40	+44	+48	+52	+56	15	-37	-47	-57	-68	-80	-93	-108	-126	-150	-180	-216	-252	-290	0	0	0	0	0	0					
50	65	+380	+240	+170	55	+140	+84	+42	+12	+12	0	0	+13	+20	+34	+40	+44	+48	+52	+56	+60	15	-43	-53	-64	-76	-89	-103	-120	-144	-174	-210	-252	-300	-350	0	0	0	0	0	0					
65	80	+400	+260	+190	55	+160	+96	+48	+12	+12	0	0	+14	+22	+38	+44	+48	+52	+56	+60	+64	15	-51	-61	-73	-86	-100	-116	-144	-178	-216	-258	-306	-354	-400	0	0	0	0	0	0					
80	100	+420	+280	+210	55	+180	+108	+54	+12	+12	0	0	+15	+24	+42	+48	+52	+56	+60	+64	+68	15	-54	-64	-77	-91	-105	-123	-156	-192	-234	-282	-330	-378	-420	0	0	0	0	0	0					
100	120	+440	+300	+230	55	+200	+120	+60	+12	+12	0	0	+16	+26	+46	+52	+56	+60	+64	+68	+72	15	-63	-74	-87	-101	-115	-135	-170	-210	-252	-300	-348	-390	-420	0	0	0	0	0	0					
120	140	+460	+320	+250	55	+220	+132	+66	+12	+12	0	0	+18	+30	+52	+58	+62	+66	+70	+74	+78	15	-75	-87	-101	-115	-130	-150	-186	-228	-270	-310	-340	-360	0	0	0	0	0	0						
140	160	+480	+340	+270	55	+240	+144	+72	+12	+12	0	0	+20	+34	+58	+64	+68	+72	+76	+80	+84	15	-87	-100	-115	-130	-146	-168	-204	-240	-270	-290	-300	-310	-310	0	0	0	0	0	0					
160	180	+500	+360	+290	55	+260	+156	+78	+12	+12	0	0	+22	+38	+64	+70	+74	+78	+82	+86	+90	15	-100	-114	-130	-146	-160	-180	-210	-230	-240	-240	-240	-240	-240	0	0	0	0	0	0					
180	200	+520	+380	+310	55	+280	+168	+84	+12	+12	0	0	+24	+42	+70	+76	+80	+84	+88	+92	+96	15	-114	-129	-146	-162	-174	-190	-210	-220	-220	-220	-220	-220	-220	0	0	0	0	0	0					
200	225	+540	+400	+330	55	+300	+180	+90	+12	+12	0	0	+26	+46	+76	+82	+86	+90	+94	+98	+102	15	-129	-145	-162	-178	-186	-200	-210	-210	-210	-210	-210	-210	-210	0	0	0	0	0	0					
225	250	+560	+420	+350	55	+320	+200	+100	+12	+12	0	0	+28	+50	+80	+86	+90	+94	+98	+102	+106	15	-144	-161	-178	-194	-200	-210	-210	-210	-210	-210	-210	-210	-210	0	0	0	0	0	0					
250	280	+580	+440	+370	55	+340	+220	+110	+12	+12	0	0	+30	+54	+86	+92	+96	+100	+104	+108	+112	15	-160	-178	-194	-210	-210	-210	-210	-210	-210	-210	-210	-210	-210	-210	0	0	0	0	0	0				
280	315	+600	+460	+390	55	+360	+240	+120	+12	+12	0	0	+32	+58	+92	+98	+102	+106	+110	+114	+118	15	-177	-195	-210	-220	-220	-220	-220	-220	-220	-220	-220	-220	-220	-220	0	0	0	0	0	0				
315	355	+620	+480	+410	55	+380	+260	+130	+12	+12	0	0	+34	+62	+98	+104	+108	+112	+116	+120	+124	15	-195	-213	-220	-230	-230	-230	-230	-230	-230	-230	-230	-230	-230	-230	-230	0	0	0	0	0	0			
355	400	+640	+500	+430	55	+400	+280	+140	+12	+12	0	0	+36	+66	+104	+110	+114	+118	+122	+126	+130	15	-213	-231	-230	-240	-240	-240	-240	-240	-240	-240	-240	-240	-240	-240	-240	-240	0	0	0	0	0	0		
400	450	+660	+520	+450	55	+420	+300	+150	+12	+12	0	0	+38	+70	+110	+116	+120	+124	+128	+132	+136	15	-231	-249	-240	-250	-250	-250	-250	-250	-250	-250	-250	-250	-250	-250	-250	-250	-250	0	0	0	0	0	0	
450	500	+680	+540	+470	55	+440	+320	+160	+12	+12	0	0	+40	+74	+116	+122	+126	+130	+134	+138	+142	15	-249	-267	-250	-260	-260	-260	-260	-260	-260	-260	-260	-260	-260	-260	-260	-260	-260	0	0	0	0	0	0	
500	560	+700	+560	+490	55	+460	+340	+170	+12	+12	0	0	+42	+78	+120	+126	+130	+134	+138	+142	+146	15	-267	-285	-260	-270	-270	-270	-270	-270	-270	-270	-270	-270	-270	-270	-270	-270	-270	0	0	0	0	0	0	
560	630	+720	+580	+510	55	+480	+360	+180	+12	+12	0	0	+44	+82	+124	+130	+134	+138	+142	+146	+150	15	-285	-303	-260	-280	-280	-280	-280	-280	-280	-280	-280	-280	-280	-280	-280	-280	-280	0	0	0	0	0	0	
630	710	+740	+600	+530	55	+500	+380	+190	+12	+12	0	0	+46	+86	+128	+134	+138	+142	+146	+150	+154	15	-303	-321	-260	-290	-290	-290	-290	-290	-290	-290	-290	-290	-290	-290	-290	-290	-290	-290	0	0	0	0	0	0
710	800	+760	+620	+550	55	+520	+400	+200	+12	+12	0	0	+48	+90	+132	+138	+142	+146	+150	+154	+158	15	-321	-339	-260	-300	-300	-300	-300	-300	-300	-300	-300	-300	-300	-300	-300	-300	-300	-300	0	0	0	0	0	0
800	900	+780	+640	+570	55	+540	+420	+210	+12	+12	0	0	+50	+94	+136	+142	+146	+150	+154	+158	+162	15	-339	-357	-260	-310	-310	-310	-310	-310	-310	-310	-310	-310	-310	-310	-310	-310	-310	-310	0	0	0	0	0	0
900	1000	+800	+660	+590	55	+560	+440	+220	+12	+12	0	0	+52	+98	+140	+146	+150	+154	+158	+162	+166	15	-357	-375	-260	-320	-320	-320	-320	-320	-320	-320	-320	-320	-320	-320	-320	-320	-320	-320	0	0	0	0	0	0
1000	1120	+820	+680	+610	55	+580	+460	+230	+12	+12	0	0	+54	+102	+144	+150	+154	+158	+162	+166	+170	15	-375	-393	-260	-330	-330	-330	-330	-330	-330	-330	-330	-330	-330	-330	-330	-330	-330	-330	0	0	0	0	0	0
1120	1250	+840	+700	+630	55	+600	+480	+240	+12	+12	0	0	+56	+106	+148	+154	+158																													



CORPORATE STANDARD

AA0230201

Rev. No. 02

PAGE 21 of 31

10.0 BIBLIOGRAPHY

The following standards on tolerancing and tolerance systems will be useful with regard to the application of this part of ISO 286:

AA0423103 (ISO 406) Technical drawings - Linear and angular tolerances - Indications on drawings.

AA0230415 (ISO 1101) Technical drawings - Geometrical tolerancing - Tolerancing of form, orientation, location and run out - Generalities, definitions, symbols, indications on drawings.

ISO 1829, Selection of tolerance zones for general purposes.

ISO 1947, System of cone tolerances for conical work pieces from C = 1:3 to 1:500 and lengths from 6 to 630 mm.

AA0230416 (ISO 2692) Technical drawings - Geometrical tolerancing Maximum material principle.

AA0230208 (ISO 2768-1) General tolerances for dimensions without tolerance indications - Part 1: Tolerances for linear and angular dimensions.¹⁾

ISO 5166, System of cone fits for cones from C = 1:3 to 1 : 500 lengths from 6 to 630 mm and diameters up to 500 mm.

11.0 REFERRED STANDARDS (Latest publications including amendment)

- | | |
|-----------------------|----------------|
| 1) AA0230206 | 9) ISO 406 |
| 2) AA0230415 | 10) ISO 1101 |
| 3) AA0423103 | 11) ISO 1829 |
| 4) AA0230416 | 12) ISO 1947 |
| 5) AA0230208 | 13) ISO 2692 |
| 6) ISO 8015 IS: 12160 | 14) ISO 2768-1 |
| 7) ISO 1 | 15) ISO 5166 |
| 8) ISO/R 1938 | |

At present at the stage of draft. (Revision, in part of ISO 2768-1973)

CS-020-9 10/3/15

AA0230201
Rev. No. 02
PAGE 22 of 31

CORPORATE STANDARD



Annex A

Bases of the ISO System of limits and fits

A.3 General

This annex gives the bases of the ISO system of limits and fits. The data are given primarily so that values can be calculated for fundamental deviations, which may be required in very special circumstances and which are not given in the tables, and also so that a more complete understanding of the system is provided.

It is once more emphasized that the tabulated values in either this corporate standard or AA0230206 standard tolerances and fundamental deviations, are definitive, and shall be used when applying the system.

A.4 Basic size steps

For convenience, the standard tolerances and fundamental deviations are not calculated individually for each separate basic size, but for steps of the basic size as given in table 4. These steps are grouped into main steps and intermediate steps. The intermediate steps are only used in certain cases for calculating standard tolerances and fundamental deviations a to c and r to zc for shafts, and A to C and R to ZC for holes.

The values of the standard tolerances and fundamental deviations for each basic size step are calculated from the geometrical mean (D) of the extreme sizes (D₁ and D₂) of that step as follows:

$$D = \sqrt{D_1 \times D_2}$$

For the first basic size step (less than or equal to 3 mm) the geometrical mean, D according to convention, is taken between the sizes 1 and 3 mm, therefore D = 1.732 mm.

CSO 229 10/3/16



CORPORATE STANDARD

AA0230201

Rev. No. 02

PAGE 23 of 31

Table 4 – Basic size steps

Values in millimetres

Basic sizes up to 500 mm (incl.)			
Main steps		Intermediate steps ¹⁾	
Above	Up to and including	Above	Up to and including
-	3	No subdivision	
3	6		
6	10		
10	18	10 14	14 18
18	30	18 24	24 30
30	50	30 40	40 50
50	80	50 65	65 80
80	120	80 100	100 120
120	180	120 140 160	140 160 180
180	250	180 200 225	200 225 250
250	315	250 280	280 315
315	400	315 355	355 400
400	500	400 450	450 500

Basic sizes above 500 mm up to 3150 mm (incl.)			
Main steps		Intermediate steps ²⁾	
Above	Up to and including	Above	Up to and including
500	630	500 560	560 630
630	800	630 710	710 800
800	1000	800 900	900 1000
1000	1250	1000 1120	1120 1250
1250	1600	1250 1400	1400 1600
1600	2000	1600 1800	1800 2000
2000	2500	2000 2240	2240 2500
2500	3150	2500 2800	2800 3150

A.5 Standard tolerance grades

A.5.1 General

ISO system of limits and fits provides for 20 standard tolerance grades designated IT01, IT0, IT1....IT18 in the size range from 0 up to 500 mm (incl.) and 18 standard tolerance grades in the size range from 500 mm up to 3150 mm (incl.) designated IT1 to IT18.

As stated in the "Foreword" the ISO system is derived from ISA Bulletin 25, which only covered basic sizes up to 500 mm, and was mainly based on practical experience in industry. The system was not developed from a coherent mathematical base, and hence there are discontinuity in the system and differing formulae for the deviation of IT grades up to 500 mm.

The values for standard tolerances for basic sizes from 500 mm up to 3150 mm (incl.) were subsequently developed for experimental purposes, and since they have proved acceptable to industry they are now given as a part of the ISO system.

It should be noted that values for standard tolerances in grades IT0 and IT01 are not given in the main body of the standard because they have little use in practice; however, values for these are given in table 5.

- These are used in certain cases for deviations a to b and r to zc or A to C and R to ZC (see tables 2 and 3).
- These are used for the deviations r to u and R to U (see tables 2 and 3).

CS-0229 10/3/15

AA0230201
 Rev. No. 02
 PAGE 24 of 31

CORPORATE STANDARD



Table 5 - Numerical values for standard tolerances in grades IT01 and IT0

Basic size mm		Standard tolerance grades	
Above	Up to and including	IT01	IT0
		Tolerances μm	
-	3	0.3	0.5
3	6	0.4	0.6
6	10	0.4	0.6
10	18	0.5	0.8
18	30	0.6	1
30	50	0.6	1
50	80	0.8	1.2
80	120	1	1.5
120	180	1.2	2
180	250	2	3
250	315	2.5	4
315	400	3	5
400	500	4	6

A.5.2 Derivation of standard tolerances (IT) for basic sizes up to and including 500 mm

A.5.2.1 Standard tolerance grades IT01 to IT4

The values of standard tolerances in grades IT01, IT0 and IT1 are calculated from the formulae given in table 6. It should be noted that no formulae are given for grades IT2, IT3 and IT4. The values for tolerances in these grades have been approximately scaled in geometrical progression between the values for IT1 and IT5.

Table 6 - Formulae for standard tolerances in grades IT01, IT0 and IT1 for basic sizes up to and including 500 mm

Values in micrometers

Standard tolerance grade	Formula for calculation where D is geometric mean of the basic size in millimetres
IT01 ¹⁾	$0.3+0.008D$
IT0 ¹⁾	$0.5+0.012D$
IT1	$0.8+0.020D$

- See the "Foreword" and A.3.1

A.5.2.2 Standard tolerance grades IT5 to IT18

The values for standard tolerances in grades IT5 to IT18 for basic sizes up to and including 500 mm are determined as a function of the standard tolerance factor, i.

The standard tolerance factor, i, in micrometres, is calculated from the following formula:

$$i = 0.45 \sqrt[3]{D} + 0.001 D$$

Where D is the geometric mean of the basic size step in millimetres (see clause A.2).

This formula was empirically derived, being based on various national practices and on the premise that, for the same manufacturing process, the relationship between the magnitude of the manufacturing errors and the basic size approximates a parabolic function.

10/2/11
65-0229



CORPORATE STANDARD

AA0230201

Rev. No. 02

PAGE 25 of 31

The values of the standard tolerances are calculated in terms of the standard tolerance factor, i , as shown in table 7.

It should be noted that from IT6 upwards, the standard tolerances are multiplied by a factor of 10 at each fifth step. This rule applies to all standard tolerances and may be used to extrapolate values for IT grades above IT18.

Example:

$$IT_{20} = IT_{15} \times 10 = 640i \times 10 = 6400i$$

Note – The above rule applies except for IT6 in the basic size range from 3 to 6 mm (incl.)

Table 7 – Formulae for standard tolerances in grades IT1 to IT18

Basic size mm		Standard tolerance grades																	
		IT1 ¹⁾	IT2 ²⁾	IT3 ³⁾	IT4 ⁴⁾	IT5	IT6	IT7	IT8	IT9	IT10	IT11	IT12	IT13	IT14	IT15	IT16	IT17	IT18
Above	Up to and including	Formulae for standard tolerances (Results in micrometres)																	
-	500	-	-	-	-	$7i$	$10i$	$16i$	$25i$	$40i$	$64i$	$100i$	$160i$	$250i$	$400i$	$640i$	$1000i$	$1600i$	$2500i$
500	3150	$2i$	$2.7i$	$3.7i$	$5i$	$7i$	$10i$	$16i$	$25i$	$40i$	$64i$	$100i$	$160i$	$250i$	$400i$	$640i$	$1000i$	$1600i$	$2500i$

– See A.3.2.1

A.5.3 Derivation of standard tolerances (IT) for basic sizes from 500 mm up to and including 3150 mm

The values for standard tolerances I grades IT1 to IT18 are determined as a function of the standard tolerance factor, I .

Standard tolerance factor, I , in micrometres, is calculated from the following formula:

$$I = 0.004D + 2.1$$

Where D is the geometric mean of the basic size step in millimetres (see clause A.2).

The values of the standard tolerances are calculated in terms of the standard tolerance factor, i , as shown in table 7.

It should be noted that from IT6 upwards, the standard tolerances are multiplied by a factor of 10 at each fifth step. This rule applies to all standard tolerances and may be used to extrapolate values for IT grades above IT18.

Examples:

$$IT_{20} = IT_{15} \times 10 = 640i \times 10 = 6400i$$

NOTES

- The formulae for standard tolerance in grades IT1 to IT5 are given on a provisional basis only. (These did not appear in ISO/R 286-1962)
- Although the formulae for i and I vary, continuity of progression is assured for the transition range.

CS-0229 18/3/15

AA0230201
 Rev. No. 02
 PAGE 26 of 31

CORPORATE STANDARD



A.5.4 Rounding of values for standard tolerances

For each basic size step, the values obtained from the formulae given in A.3.2 and A.3.3 for standard tolerances in grades up to and including IT11, are rounded off in accordance with the rules given in table 8.

The calculated values of standard tolerances in grades above IT11 do not require rounding off because they are derived from values of tolerance grade IT7 to IT11, which have already been rounded off.

Table 8 - Rounding for IT values up to and including standard tolerance grade IT11

Calculated values obtained from the formulae given in A.3.2 and A.3.3		Rounding values in micrometres	
		Up to 500 mm (incl.)	Above 500 mm up to 3150 mm (incl.)
Above	Up to and including	Rounding in multiples of	
0	60	1	1
60	100	1	2
100	200	5	5
200	500	10	10
500	1000	-	20
1000	2000	-	50
2000	5000	-	100
5000	10000	-	200
10000	20000	-	500
20000	50000	-	1000

NOTES

- For the small values in particular, it has sometimes been necessary to depart from these rules, and, in some instances, even from the application of the formulae given in A.3.2 and A.3.3 in order to ensure better scaling. Therefore the values given for the standard tolerances in tables 1 to 5 as appropriate, shall be used in preference to calculated values when applying the ISO system.
- Values for standard tolerances in grades IT1 to IT18 are given in table 1 and for IT0 and IT01 in table 5.

A.6 Derivation of fundamental deviations

A.6.1 Fundamental deviations for shafts

The fundamental deviations for shafts are calculated from the formulae given in table 9.

The fundamental deviation given by the formulae in table 9 is, in principle, that corresponding to the limits closest to the zero line i.e. the upper deviation for shafts a to h and the lower deviation for shafts k to zc.

Except for shafts j and js, for which, strictly speaking, there is no fundamental deviation, the value of the deviation is independent of the selected grade of tolerance (even if the formula includes a term involving IT_n).

A.6.2 Fundamental deviations for holes

The fundamental deviations for holes are calculated from the formulae given in table 9 and, therefore, the limit corresponding to the fundamental deviation for a hole is exactly symmetrical in relation to the zero line, to the limit corresponding to the fundamental deviation for a shaft with the same letter.

CS-0227 10/3/15



CORPORATE STANDARD

AA0230201

Rev. No. 02

PAGE 27 of 31

This rule applies to all fundamental deviations except for the following.

- Deviation N, for standard tolerance grades IT9 to IT16 in basic sizes above 3 mm up to 500 mm (incl.) for which the fundamental deviation is zero.
- Shaft of hole basis fits, for basic sizes above 3 up to 500 mm (incl.) in which a hole of a given standard tolerance grade is associated with a shaft of the next finer grade (e.g) H7/P6 and P7/h6) and which are required to have exactly the same clearance or interferences, see figure 20.

In the cases, the fundamental deviation, as calculated, is adjusted by algebraically adding the value of Δ as follows:

$$ES = ES \text{ (as calculated)} + \Delta$$

Where Δ is the difference $IT_n - IT_{(n-1)}$ between the standard tolerance, for the basic size step in the given grade, and that in the next finer grade.

Example:

For P7 in the basic size range from 18 to 30 mm:

$$\Delta = IT_7 - IT_6 = 21 - 13 = 8 \mu\text{m}$$

NOTE - The rule given in b) above is only applicable for basic sizes over 3 mm for fundamental deviations K, M and N in standard tolerance grades up to and including IT8 and deviations P to ZC in standard tolerance grades up to and including IT7.

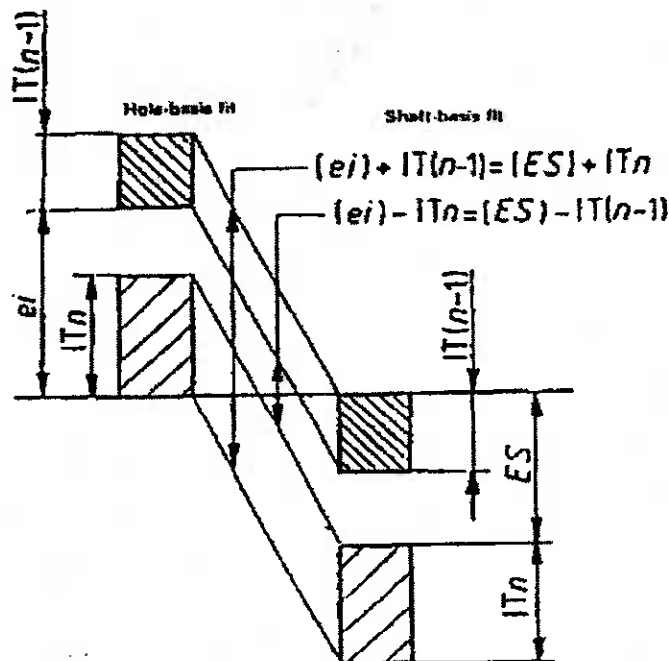

Figure 20 - Diagrammatic representation of the rule given A 4.2b)

CS-0229 10/3/15

AA0230201

Rev. No. 02

PAGE 28 of 31

CORPORATE STANDARD



The fundamental deviation given by the formulae in table 9 is, in principle, that corresponding to the limits closest to the limits closest to the zero line, i.e. the lower deviation for holes A to H and the upper deviation for holes K to ZC.

Except for holes J and JS, for which, strictly speaking, there is no fundamental deviation, the value of the deviation is independent of the selected grade of tolerance (even if the formula includes a term involving IT_n).

A.6.3 Rounding of values for fundamental deviations

For each basic size step, the values obtained from the formulae given in table 9 are rounded off in accordance with the rules given in table 10.

CS-0229 10/3/15



CORPORATE STANDARD

Table 9 - Formulae for fundamental deviations for shafts and holes

Basic size mm		Shafts			Formulae ¹⁾ where D is the geometric mean of the basic size in millimetres	Holes			Basic size mm	
Above	Up to and including	Fundamental deviation	Sign (negative or positive)	Designation		Designation	Sign (negative or positive)	Fundamental deviation	Above	Up to and including
1	120	A	-	es	265 + 1.3D	EI	+	A	1	120
120	500				3.5D				120	500
1	160	B	-	es	≈140 + 0.85D	EI	+	B	1	160
160	500				≈ 1.8D				160	500
0	40	C	-	es	52D ^{0.2}	EI	+	C	0	40
40	500				95 + 0.8D				40	500
0	10	cd	-	es	Geometric mean of the values for C.c and D.d	EI	+	CD	0	10
0	3150	d	-	es	16D ^{0.44}	EI	+	D	0	3150
0	3150	e	-	es	11D ^{0.41}	EI	+	E	0	3150
0	10	cf	-	es	Geometric mean of the values for E.e and F.f	EI	+	EF	0	10
0	3150	f	-	es	5.5D ^{0.41}	EI	+	F	0	3150
0	10	fg	-	es	Geometric mean of the values for F.f and G.g	EI	+	FG	0	10
0	3150	g	-	es	2.5D ^{0.34}	EI	+	G	0	3150
0	3150	h	No sign	es	Deviation=0	EI	No sign	H	0	3150
0	500	j			No formula ²⁾			J	0	500
0	3150	js	+	es	0.5ITn	EI	+	JS	0	3150
			-	ei						
0	500 ³⁾	k	+	ei	0.6 ³ √D	ES	-	K ⁴⁾	0	500 ³⁾
500	3150		No sign		No sign		500		3150	
0	500	m	+	ei	IT7-IT6	ES	-	M ⁴⁾	0	500
500	3150				0.024D+12.6				500	3150
0	500	n	+	ei	5D ^{0.34}	ES	-	N ⁴⁾	0	500
500	3150				0.04D + 21				500	3150
0	500	p	+	ei	IT7+ 0 to 5	ES	-	P ⁴⁾	0	500
500	3150				0.072D+37.8				500	3150
0	3150	r	+	ei	Geometric mean of the values for P,p and S.s	ES	-	R ⁴⁾	0	3150
0	50	s	+	ei	IT8 + 1 to 4	ES	-	S ⁴⁾	0	50
50	3150				IT7 + 0.4D				50	3150
24	3150	t	+	ei	IT7+0.63D	ES	-	T ⁴⁾	24	3150
0	3150	u	+	ei	IT7+D	ES	-	U ⁴⁾	0	3150
14	500	v	+	ei	IT7+1.25D	ES	-	V ⁴⁾	14	500
0	500	x	+	ei	IT7+1.6D	ES	-	X ⁴⁾	0	500
18	500	y	+	ei	IT7+2D	ES	-	Y ⁴⁾	18	500
0	500	z	+	ei	IT7+2.5D	ES	-	Z ⁴⁾	0	500
0	500	za	+	ei	IT8+3.15D	ES	-	ZA ⁴⁾	0	500
0	500	zb	+	ei	IT9+4D	ES	-	ZB ⁴⁾	0	500
0	500	zc	+	ei	IT10+5D	ES	-	ZC ⁴⁾	0	500

- Fundamental deviations (i.e. results from formula) in micrometres.
- Values only given in tables 2 and 3
- Formula only applies to grades IT4 to IT7 inclusively; fundamental deviation k for all other basic sizes and all other IT grades = 0
- Special rule applies (see A.4.2.b)
- Formula only applies to grades up to IT8 inclusively; fundamental deviation K for all other basic sizes and all other IT grades = 0

CS-0229 10/3/15

AA0230201

Rev. No. 02

PAGE 30 of 31

CORPORATE STANDARD



Table 10 – Rounding for fundamental deviations

Rounding values in micrometres

Calculated vales obtained from the formulae given in table 9 µm		Basic size		
		Up to 500 mm (incl.)		Above 500 mm up to 3150 mm (incl.)
Above Up to and including		Fundamental deviations		
		a to g A to G	k to zc K to ZC	d to u D to U
		Rounding in multiples of		
5	45	1	1	1
45	60	2	1	1
60	100	5	1	2
100	200	5	2	5
200	300	10	2	10
300	500	10	5	10
500	560	10	5	20
560	600	20	5	20
600	800	20	10	20
800	1000	20	20	20
1000	2000	50	50	50
2000	5000		100	100
...
20×10^n	50×10^n			1×10^n
50×10^n	100×10^n			2×10^n
100×10^n	200×10^n			5×10^n

CS-0229 10/31/18 ✓



CORPORATE STANDARD

AA0230201

Rev. No. 02

PAGE 31 of 31

Annex B Examples of the use of ISO 286-1

B.6 General

This annex gives examples in the use of the ISO system of limits and fits, in determining the limits for shafts and holes.

The numerical values of the upper and lower deviations for the more generally used basic size steps, fundamental deviations and tolerance grades have been calculated and are tabulated in AA0230206.

In special cases, not covered by AA0230206 the appropriate upper and lower deviations, and hence the limits of size, can be calculated from the data given in tables 1 to 3, and tables 4 to 6 in annex A in this Corporate Standard.

B.7 Review of special features

A summary of the features and factors which shall be taken into consideration when using this part of ISO 286 to derive upper and lower deviations for special cases is given below:

- Shafts and holes a, A, b, B are provided only for basic sizes greater than 1 mm;
- Shafts j8 are provided only for basic sizes less than or equal to 3 mm;
- Holes K in tolerance grades above IT8 are provided only for basic sizes less than or equal to 3 mm;
- Shafts and holes t, T, v, V and y, Y are only provided for basic sizes greater than 24 mm, 14 mm and 18 mm, respectively (for smaller basic sizes, the deviations are practically the same as those of the adjacent tolerance grades);
- Tolerance grades IT14 to IT8 are only provided for basic sizes greater than 1 mm;
- Holes N of tolerance grades above IT8 are only provided for basic sizes greater than 1 mm.

B.8 Examples

B.8.1 Determining the limits of size for a shaft Φ 40g11

Basic size step: 30 to 15 mm (from table 4)

Standard tolerance = 160 μ m (from table 1)

Fundamental deviation = - 9 μ m (from table 2)

Upper deviation = fundamental deviation = - 9 μ m

Lower deviation = fundamental deviation \cdot tolerance = -9 \cdot 160 μ m = -169 μ m

Limits of size:

Maximum = 40-0.009 = 39.991 mm

Minimum = 40-0.169 = 39.831 mm

B.8.2 Determining the limits of size for hole Φ 130N4

Basic size step: 120 to 180 mm (from table 4)

Standard tolerance = 12 μ m (from table 1)

Fundamental deviation = -27 + Δ μ m (from table 3)

Value of Δ = 4 μ m (from table 3)

Upper deviation = fundamental deviation

= -27 + 4 = -23 μ m

Lower deviation = fundamental deviation - tolerance

= -23 - 12 μ m = -35 μ m

Limits of size:

Maximum = 130-0.023 = 129.977 mm

Minimum = 130-0.035 = 129.965 mm

CS-0209 10/3/15