

ANNEXURE 1

Specification for Power Conditioning Unit (PCU) for Solar Application:

1.1 Introduction:

The proposed configuration consists of three IGBT Inverters connected in parallel to form a single PCU as shown in Fig 1. Three number of (DSP + HMI controller) are proposed to control three inverter panels. The location of AC/DC contactors, sensors, IGBT Stack, LCL filter is also shown in Fig. 1. Supplier should supply items as listed in Section 1.2.1 and 1.2.2 (Table 1 and Table 2)

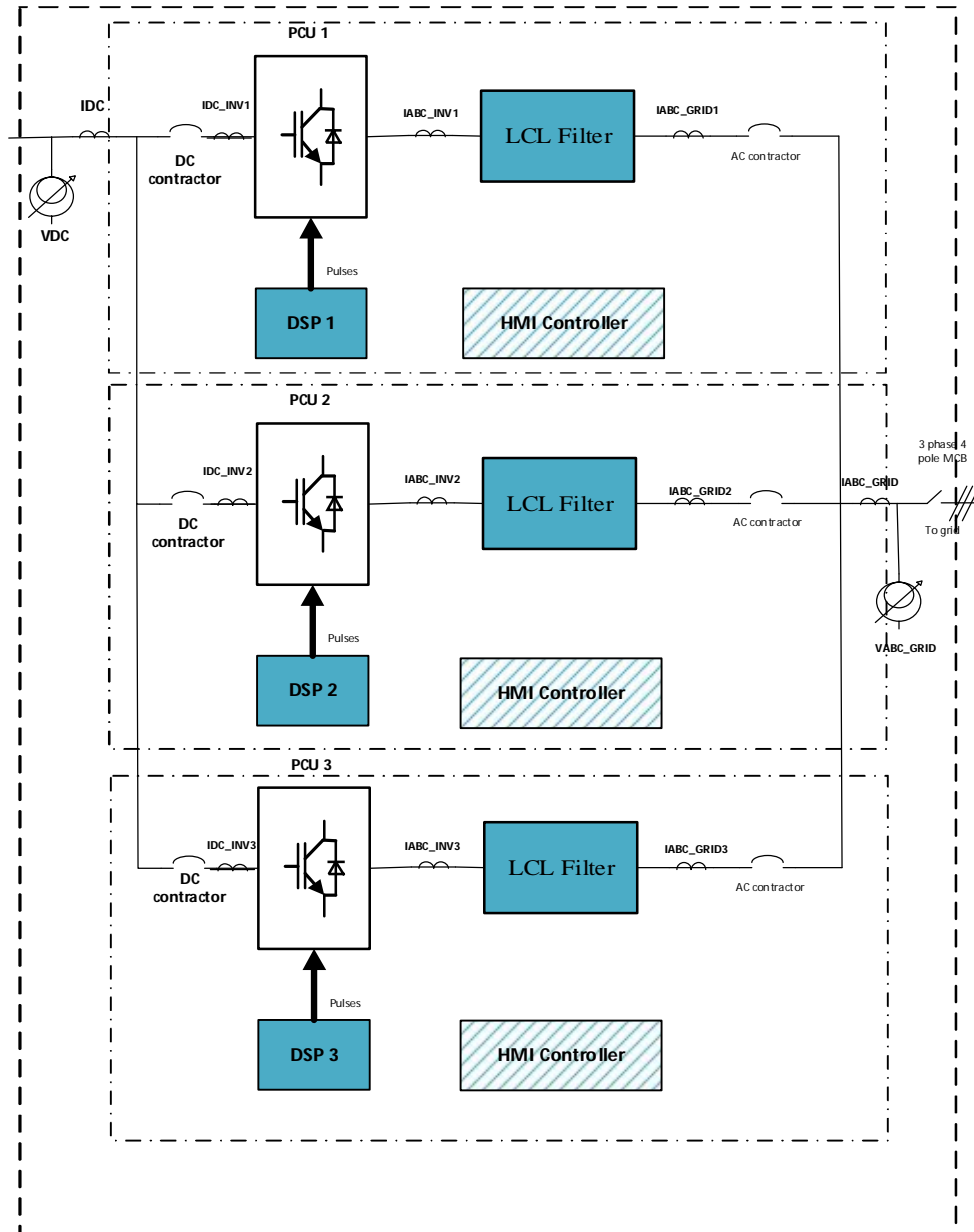

Figure 1

1.2 Bill of Material for PCU:

Cabinet:

An integrated Power panel having all necessary controls, power switches, Contactors, MCBs, indicator lamps, Push button Switches, HMIs to be incorporated as per BHEL design. Presidents **CYBERACK OEM or equivalent Cabinet Size 2068H/800W/800D** for holding variety of Power/Electronic equipment with following specifications :

- Confirmation to DIN 41494.
- Vertical pillars made of aluminium alloy extrusions capable of vertical loads of 600Kgs.
- Panel painted with RAL7032 Siemens or equivalent Grey powder coated paint

Thermal Management:

Cabinet should be designed to exhaust heat generated by IGBTs and other power components. Supplier should give a detailed thermal management calculations. Exhaust fans 8inch x 4 No's to be provided on the top ceiling of the enclosure. The bottom end to be provided with necessary louvers and perforations to allow cold air to come in. All side panels to be provided with air filters facing IGBT stacks for blocking ingress of dust into the enclosure.

Robustness:

The frame to be made of heavy grade Aluminium profiles designed to accept front and rear doors which close within the frame itself. (Max load 600Kgs)

Aesthetics:

Highly attractive appearance that blends with uncluttered look of modern control panel. The front panel enclosure is to be provided with CFL lamps, switched on opening. All of BHEL supplied items (as per Table 1 and Table 2) should be fitted in a 3 tier arrangement for the ease of connection. The cabinet used for housing should be modified, to fit all the assemblies provided by BHEL R&D. All heavy components should be mounted on rails provided along the depth of the panel. Enough DIN railings should be provided to mount MCBs, relays, power supplies, contactors and other components. A Bakelite sheet of thickness 2-3mm should be provided to mount all Controllers cards, protection cards behind the panel door. Necessary slots should be made for mounting of HMI controller on the front side of the panel. Indicating lamps and push button switches should be provided on the panel as suggested by BHEL.

All the items shown in Table 1 and 2 should be fitted to the panel prior to the delivery along with BHEL supplied items.

1.2.1 BOM for Power Circuit:

S.No.	Description	Quantity	Remark
1	Inverter Stack(25 KVA)	3	BHEL Scope
2	Three phase Inductors for LCL Filter	6	BHEL Scope
3	Capacitor for LCL filter	9	BHEL Scope
4	DC Contactor	3	BHEL Scope
5	Inverter 3 phase AC Contactor 50 A,415V(Make : Schneider)	3	Supplier Scope
6	3 phase Main AC Contactor 100 A,415V(Make : Schneider)	1	Supplier Scope
7	AC Current Sensor(Make : LEM), 50 A	18	Supplier Scope
8	AC Voltage Sensor (Make : LEM) 500V	3	Supplier Scope
9	DC Current Sensor (Make : LEM) 50 A	3	Supplier Scope
10	DC Voltage Sensor (Make : LEM)1000 V	1	Supplier Scope
11	3 phase Ganged MCB 100 A,415V 4 pole	1	Supplier Scope
12	AC wires (RYB), 16 sq mm (Make : Finolex)	50 mts	Supplier Scope
13	AC wires (RYB), 32sq mm (Make : Finolex)	150 mts	Supplier Scope

14	LUGS for wires 16 sq mm/35 sq mm	APR*	Supplier Scope
15	15 V/24 V Relay mounted on DIN Rail	20 Nos.	Supplier Scope
16	Cabinet for housing stack(Make : Cyberack or Rittal)	1 Nos.	Supplier Scope
17	Phoenix connectors mounted on DIN Rail	100 Nos.	Supplier Scope

APR = As per Requirement

Table 1

1.2.2 BOM for Control Circuit:

S.No.	Description	Quantity	Remark
1	DSP Controller	3	BHEL Scope
2	Red Lion Controller	1	BHEL Scope
3	Signal conditioning Card	3	BHEL Scope
4	Protection Card	3	BHEL Scope
5	Power Supply 15 V, 5A	2	BHEL Scope
6	Power Supply 5 V, 5A	1	BHEL Scope
7	Power Supply 24 V, 2.5 A	1	BHEL Scope
8	1.0sq mm wire (RYB)	100 m	BHEL Scope
9	LUGS for wires 1.0 sq mm	APR	BHEL Scope
10	TB for sensor and control signals	100	Supplier Scope
11	TB for Power supplies	100	Supplier Scope
12	Push Button on cabinet door	3 Nos.	Supplier Scope
13	Lamps indication on cabinet door	10 Nos.	Supplier Scope

Table 2

1.2.3 Tentative dimensions of the items under BHEL Scope

S.No	Description	Size(mm)	weight	Quantity
1	IGBT Stack	640(L)*400(W)*320(H)	30 kgs	3 numbers
2	L filter	180(L)*150(W)*160(H)	20 kgs	6 numbers
3	C filter(E62.F85-123B20)	45(D)*125(H)	.14 kgs	9 numbers
4	DSP Controller	235 * 160	-	3 numbers
5	Protection Card	190 * 160	-	3 numbers
6	Signal Conditioning Card	160 * 135	-	3 numbers
7	HMI Controller	225 * 180	1.36 kgs	3 number

Table 3

Supplier should supply, assemble and fabricate PCU as per the items listed in table 1 and table 2. Items under BHEL scope will be provided by BHEL during fabrication and supplier need to procure other items as per table 1 and table 2 required for fabrication.

Supplier should take design clearance from BHEL before fabrication of Power Panel. Pure annealed Copper material lugs (pin type, fork type, ring type) should be used for all power connection with Crimping and Heat shrinkable sleeves.

The Power circuit wiring of entire PCU will be under supplier scope. Control circuit wiring of PCU from sensors to Terminal Box (TBs), Power supply to TB and Relay interlock will be under supplier scope. Push button and indication lamps to be provided in front door. Mounting of DSP, analogue and digital cards to be done on a Bakelite sheet of thickness 2-3mm by supplier. DC and AC side termination should be at bottom or some suitable location ease of connections.