



# BHARAT HEAVY ELECTRICALS LIMITED

## TRANSMISSION PROJECTS ENGINEERING MANAGEMENT

DOCUMENT No.	<b>TB-376-522-01</b>	Rev. No.	<b>00</b>		Prepared	Reviewed	Approved
TYPE OF DOC.	<b>TECHNICAL SPECIFICATION</b>			SIGN			
TITLE	<b>FIRE FIGHTING SYSTEM</b>			NAME	<b>AR</b>	<b>SKS</b>	<b>NSR</b>
				DATE	<b>09.06.15</b>	<b>09.06.15</b>	<b>09.06.15</b>
				GROUP	<b>TBEM</b>	W.O. No	<b>86004</b>
CUSTOMER	<b>POWER GRID CORPORATION OF INDIA LIMITED (POWERGRID)</b>						
PROJECT	<b>765/400kV AGRA (UPPTCL) NEW S/S</b>						
NOA NO.	<b>CC-CS/494-NR1/SS-2546/3/G3/NOA-I/5163 &amp; 5164 dtd. 31.12.14</b>						
STATIONS	<b>AGRA</b>						

### CONTENTS

Section	Description	No. of Sheets
1	Intent, System requirement, Design Criteria and Scope.	10
2	Equipment Specification	78
3	Project Details and General Specifications	23
4	Guaranteed Technical Particulars	1
5	Enclosures to Specification <ul style="list-style-type: none"> <li>Schedule 1      Schedule of Deviations</li> <li>Schedule 2      Details of contact persons (technical &amp; commercial)</li> <li>Schedule 3      Enclosures to Specification</li> </ul>	

COPYRIGHT AND CONFIDENTIALITY  
The information on this document is the property of BHARAT HEAVY ELECTRICALS LTD.  
It must not be used directly or indirectly in anyway detrimental to the interest of the company

Rev No.	Date	Altered	Checked	Approved	REVISION DETAILS				
Distribution				To	TBEO	TBMM	TBQM	Vendor	
				Copies	1	1	1	4	

<b>Project</b>	<b>765/400KV (UPPTCL) NEW SUBSATATION AT AGRA</b>	<b>TB-376-522-01 Rev 00</b>	
<b>System</b>	<b>FIRE FIGHTING SYSTEM</b>		
<b>Owner</b>	<b>UPPTCL</b>		
<b>Customer</b>	<b>POWER GRID CORPORATION OF INDIA LTD</b>		
<b>Purchaser</b>	<b>BHEL (TRANSMISSION BUSINESS GROUP)</b>		

## SECTION 1

### INTENT, SYSTEM REQUIREMENT, DESIGN CRITERIA AND SCOPE

#### 1.0.0 INTENT OF SPECIFICATION

- 1.1.0 This specification is intended to specify the requirements for design, engineering, manufacture, assembly, stage testing, inspection, testing before supply, packing, forwarding, transportation at site, unloading, storage, complete erection of all equipment and accessories, testing of the system, trial run, commissioning of the system, final painting and carrying out acceptance test of Fire Fighting System along with its accessories and auxiliary equipments / instruments etc. at Agra site as mentioned in this section and in various other sections of this specification for **765/400KV New Sub-station at Agra of Power Grid Corporation of India Limited (POWERGRID)**.
- 1.2.0 The system shall be designed, erected & commissioned in accordance with **TAC/ NFPA** guidelines.
- 1.3.0 Requirements pertaining to type, make, quality, testing & inspection of equipments as laid down in various clauses of CUSTOMER Specification, enclosed in Section 2, shall be full & final. In the event of any contradiction w.r.t. other sections of this specification, technical requirements of Section 1 & 2 shall prevail.
- 1.4.0 The Bidder shall be deemed to have understood completely all the tender drawings and documents and quoted accordingly.
- 1.5.0 It is not the intent to specify herein all the details of design and manufacture. However, the equipment shall conform in all respect to high standards of design, engineering and workmanship and shall be capable of performing the required duties in a manner acceptable to Purchaser / Owner, who will interpret the meaning of drawings and specifications and shall be entitled to reject any work or material, which in his/their judgment is not in full accordance with the specifications.
- 1.6.0 The Bidder to note carefully that parameters, estimated capacities of equipment indicated and the tender drawings in the specification are only for the guidance of the Bidder. The system shall be designed as per relevant standards/ codes and exact capacities and quantities are to be estimated by the Bidder. All such estimations and design calculations shall be submitted for Purchaser's approval.
- 1.7.0 **The contract shall be on lump-sum basis for the package. Within the scope of the contract, no variation shall be admissible to the contractor so far the input remains unchanged. In case of variations due to unforeseen changes in scope during contract stage, the additions/deletions to the scope shall be settled on the basis of mutually agreed rates**
- 1.8.0 The term 'Owner' appearing in this specification shall refer to **UPPTCL**, the term **Customer** shall refer to **POWERGRID**, 'Purchaser' shall refer to **BHEL** and the term 'Contractor' shall refer to the **successful Bidder**.
- 1.9.0 There shall preferably be no deviation on technical specification. The bidder shall sign and stamp the "Certificate for No Deviation" enclosed in Schedule-3, Section-5 towards confirmation. ***Deviations in any other form including clarifications / assumptions / observations, input data in the GTP etc will not be considered and it will be construed that the bid conforms strictly to the specification.***

<b>Project</b>	<b>765/400KV (UPPTCL) NEW SUBSATATION AT AGRA</b>	<b>TB-376-522-01 Rev 00</b>	
<b>System</b>	<b>FIRE FIGHTING SYSTEM</b>		
<b>Owner</b>	<b>UPPTCL</b>		
<b>Customer</b>	<b>POWER GRID CORPORATION OF INDIA LTD</b>		
<b>Purchaser</b>	<b>BHEL (TRANSMISSION BUSINESS GROUP)</b>		

## 2.0.0 TYPE OF FIRE PROTECTION REQUIRED

### AGRA NEW S/s

- i) Hydrant system for all the buildings in the substation viz. control building, Transformers, Reactors, LT transformer area (auxiliary transformer), fire fighting pump house, DG Set and store.
- ii) No. of auxiliary transformer/ s: 02 (Two) Number of 800kVA, 33/0.433kV LT transformer. Location of Aux. Transformer: As per attached layout
- iii) HVW spray system for:
 

Rating of Bus Reactors without NGR & Nos.: 125 MVAR, 400 kV, 3- phase Reactors-1No.  
: 80 MVAR, 765 kV, 1- phase Reactors-4 Nos.

Rating of Shunt Reactors with NGR & Nos. : 80MVAR, 765 kV, 1- phase Reactors-7 Nos.

*OGA of 125 MVAR (BHEL make) & 80MVAR reactor (Alstom make) is enclosed for reference and estimation purpose only*

Rating of Auto-Transformers/ s : 500 MVA, 765/400, 1-phase Autotransformer  
No. of Auto Transformers : 07 Nos.  
*(OGA of 500MVA Transformer is attached to this spec. for reference and estimation purpose only)*
- iv) Conventional fire detection & alarm system for 8 Nos. Switchyard Panel Rooms (under present scope) and Control Room Building. (Locations of AC Panel rooms are shown in the plot plan layout attached to this spec.)
- v) Capacity and qty. of fire extinguishers are given in scope of supply Cl No. 4.1.0. These extinguishers shall be installed in Switchyard Panel Rooms, Control Room Building, Fire Fighting pump house, LT transformers & DG set areas. Distribution of these shall be finalized during detailed engineering.

## 3.0.0 DESIGN CRITERIA

- 3.0.1 The equipment offered shall comply with the relevant Indian Standards. The equipment conforming to any other approved international standards shall meet the requirement called for in the latest revision of relevant Indian Standard or shall be superior. The Deluge valves, HVW spray nozzles & quartzoid bulb detectors shall have the approval of any of the following agencies;
  - a. UL of USA.
  - b. F M of USA
  - c. LPCB of UK or
  - d. VDS of Germany,
- 3.0.2 Light Hazard occupancy shall be considered for hydrant protection.
- 3.0.3 All the requirements regarding supplies, provisions of control, interlocks, indications, annunciations, alarms etc, stipulated in various clauses of POWERGRID specification (Section2) shall be satisfied by the contractor in totality.
- 3.0.4 It is contractor's responsibility to prepare the standard HVW spray drawing of Reactors & Transformers of each rating/type/make and get approval on the same from Powergrid as a part of standardization which is a normal practice in any sub-station project.

<b>Project</b>	<b>765/400KV (UPPTCL) NEW SUBSATATION AT AGRA</b>	<b>TB-376-522-01 Rev 00</b>	
<b>System</b>	<b>FIRE FIGHTING SYSTEM</b>		
<b>Owner</b>	<b>UPPTCL</b>		
<b>Customer</b>	<b>POWER GRID CORPORATION OF INDIA LTD</b>		
<b>Purchaser</b>	<b>BHEL (TRANSMISSION BUSINESS GROUP)</b>		

### 3.0.5 Interfacing Requirement

Provision of sufficient potential free contacts in FAP to repeat all the fire fighting system alarms in *SAS (Substation automation system)* as specified in various clause of customer specification attached in section-2 *including annunciation for future switchyard panel rooms (4 Nos.) & future transformer/reactors (12 Nos.)*

### 4.0.0 SCOPE OF SUPPLIES & SERVICES

The requirements mentioned under this clause are *indicative and minimum* for the system. Any other item/ service required to complete the work for safe and sound operation of system (as under customer technical specification enclosed under section-2) shall be provided and installed by the bidder at no extra cost to the BHEL. The bidder may bring out such requirement(s) suitably.

### 4.1.0 SCOPE OF SUPPLY

*Complete supply for AGRA New S/s consists of following heads:*

Sr. No.	System	Areas Covered	QTY
1	Hydrant System	<ul style="list-style-type: none"> <li>a) Control room Building</li> <li>b) LT transformer area</li> <li>c) Fire Fighting pump House</li> <li>d) Store</li> <li>e) Auto Transformers</li> <li>f) Bus and Shunt Reactors</li> </ul>	1 Lot
2	Conventional Fire Detection and alarm System (As per customer spec. CI No-2.03.00 attached to Section-2)	<ul style="list-style-type: none"> <li>a) Switchyard Control Room Building</li> <li>b) Switchyard panel rooms</li> </ul>	1 Lot
3	HVW Spray System	<ul style="list-style-type: none"> <li>a) 7 Nos. of 500 MVA, 765/400 kV ,1-phase Autotransformer</li> <li>b) 7 Nos. of 80 MVAR, 765 kV Shunt reactor with NGR, 1- phase</li> <li>c) 4 Nos. of 80 MVAR, 765 kV Bus reactor without NGR, 1- phase</li> <li>d) 1 No. of 125 MVAR, 400 kV Bus reactor without NGR, 1- phase</li> </ul>	1 Lot

<b>Project</b>	<b>765/400KV (UPPTCL) NEW SUBSATATION AT AGRA</b>	<b>TB-376-522-01 Rev 00</b>	
<b>System</b>	<b>FIRE FIGHTING SYSTEM</b>		
<b>Owner</b>	<b>UPPTCL</b>		
<b>Customer</b>	<b>POWER GRID CORPORATION OF INDIA LTD</b>		
<b>Purchaser</b>	<b>BHEL (TRANSMISSION BUSINESS GROUP)</b>		

4	Pumping arrangement for HVW system & hydrant system, complete with all piping, valves, fittings, puddle flange etc. inside pump house as per Powergrid technical specification attached to section-2.	For supply of water to hydrant and HVW system	1 Lot
5	Fire Extinguishers as per Powergrid technical specification attached to section-2.	i) 9 Lt Water type ii) 4.5 kg CO2 type iii) 5Kg DCP type iv) 50 Lt. Mechanical foam type	4 Nos. 12 Nos. 4 Nos. 2 Nos.
10	Civil	RCC Pedestals for above ground piping Deluge valve housings Pylon supports for HVW spray system	1 Lot
11	Electricals	As per CI No. 2.06 of POWERGRID Specification attached under section-2.	1 Lot
12	Mandatory Spares Deluge Valve	One no. of each size.	1 Lot
13	Erection, Testing & commissioning	For complete fire fighting system as per specification.	1 Lot

Besides, the Bidder shall take a note of the following while preparing his offer:

- a. Water shall be provided at one point on switchyard fencing. However for estimation purpose, tap-off shall be considered at a distance of 100 metres from fire water reservoir. 100 NB MS pipe shall be considered to connect tap off point to water reservoir. Location of open store may be considered at a distance of 100 meter from pump house.
- b. One no. gate valve with a blinding flange suitable for 40NB pipe shall be provided on the main incomer to water reservoir for tapping water supply to control building. Piping further from this valve to control building shall be in other's scope.
- c. BIDDER IN HIS OFFER SHALL FURNISH THE REQUIREMENT OF FEEDERS i.e NOS., TYPE & RATING FOR PUMP HOUSE & CONTROL ROOM. PURCHASER WILL LAY THE MAIN INCOMER CABLES UPTO THE PANELS IN THESE AREAS, HOWEVER TERMINATION OF THESE CABLES SHALL BE DONE BY CONTRACTOR. ALL CABLING FURTHER FROM THESE PANELS TO EQUIPMENT UNDER CONTRACTOR'S SCOPE OF SUPPLY AND FOR CONTROL & INTERLOCKING OF VARIOUS EQUIPMENTS SHALL BE IN CONTRACTOR'S SCOPE.
- d. Power & Control cables for fire protection system (except for Detection & alarm system) will be supplied on free issue basis to contractor. BHEL shall procure various sizes of cables (*as per Annexure 'A' of this section*) for the complete requirement of sub-station. Contractor shall have to

<b>Project</b>	<b>765/400KV (UPPTCL) NEW SUBSATATION AT AGRA</b>	<b>TB-376-522-01 Rev 00</b>	
<b>System</b>	<b>FIRE FIGHTING SYSTEM</b>		
<b>Owner</b>	<b>UPPTCL</b>		
<b>Customer</b>	<b>POWER GRID CORPORATION OF INDIA LTD</b>		
<b>Purchaser</b>	<b>BHEL (TRANSMISSION BUSINESS GROUP)</b>		

choose their cables from the available sizes only and necessary modifications in their equipment for termination of these cables shall be made by contractor.

- e. Since laying & termination of all power & control cables is in contractor's scope, supply of cable accessories such as lugs, glands, cable tags & markers etc. shall be included by the bidders in their offers alongwith supply of cable for fire detection and alarm system. **Cables for detection and alarm system shall be 2.03.04 of POWERGRID specification attached under section-2.**
- f. All other areas of control building except toilets, pantry, battery room, battery charger room, AC/DC distribution room, shall be considered to be having false ceiling.
- g. Necessary cable trays will be supplied on free issue basis to the contractor, however necessary hardware for fixing the same on walls or elsewhere shall be included by the bidders in their offers.
- h. Earthing material viz. GS flat & wire will also be supplied on free issue basis to contractor, however requirement shall be given by the bidders in their respective bids and earthing of fire fighting equipments shall be done by contractor.
- i. Pipe structure for pylon support around transformer shall be fixed to the bottom of sump with the help of Anchor fastners. The structure will be in two pieces with a flanged joint at around Zero level above chequered plate. Pipe size for pylon, size of Anchor fasteners etc. shall be adequate for the support to provide sufficient rigidity against vibration & load during operation. The whole arrangement shall be in bidder's scope. The contractor shall justify adequacy of design during engineering.
- j. All the nozzles and flanges in fire- water reservoir shall be supplied by the contractor. Similarly valves for nozzles for drain shall also be supplied by the contractor. Bidders shall consider the price for the same in their respective bids.
- k. Contractor shall submit valid Type test report for approval by owner. Fresh type test of equipment is not envisaged. It is presumed that equipments offered are duly type tested.

Type Test Certificate for degree of protection shall be submitted for the following:

1. Deluge Valve local control panel
2. All other electrical panels in pump house and control room as per customer specification.

In case the type test reports are found un-satisfactory, tests shall be carried out afresh by contractor without any additional cost implication to BHEL. The final decision for accepting/Rejecting of type test report shall be of POWERGRID. Hence contractor must ensure that panel manufacturer has valid and Powergrid approved type test report before ordering.

- l. Bidder shall choose the makes from among the list of POWERGRID approved makes enclosed in Schedule-10 of Section-5. Besides, any other vendor listed in POWERGRID's "compendium of approved vendors", which is available on the internet, can also be chosen. In case, no vendor is specified in compendium against a particular item, only reputed makes available in the market shall be considered. All such makes shall be subjected to acceptance of POWERGRID. No additional price implication shall be made to BHEL on account of non-acceptance of proposed makes by POWERGRID.
- m. All the components except transformer & reactor as appearing in the P&I diagram (as a part of Powergrid specification attached in section-2) are in contractor's scope of supply & ETC. **Also bidder should note that the pipe/valve sizes mentioned in the P&I is minimum and indicative requirement. Bidder should decide the pipe size of header to take care of requirement of hydrant and spray for reactor/transformer based on the hydraulic calculation and consider the same in his offer. There shall not be any price implication to BHEL/Powergrid due to change of any pipe/valve size during detailed engineering.**

<b>Project</b>	<b>765/400KV (UPPTCL) NEW SUBSATATION AT AGRA</b>	<b>TB-376-522-01 Rev 00</b>	
<b>System</b>	<b>FIRE FIGHTING SYSTEM</b>		
<b>Owner</b>	<b>UPPTCL</b>		
<b>Customer</b>	<b>POWER GRID CORPORATION OF INDIA LTD</b>		
<b>Purchaser</b>	<b>BHEL (TRANSMISSION BUSINESS GROUP)</b>		

- n. **While making his Bid, Bidder should check the requirements carefully for 400kV & 220kV sub-stations, which are clearly demarcated in Section-2.**
- o. Any spares required for commissioning purpose shall be supplied separately by the contractor.

#### 4.2.0 SCOPE OF SERVICES

##### 4.2.1 Erection, Testing & Commissioning (ETC) requirements

- a) The scope of ETC shall include receipt of material at site, safe storage of material, handling of equipment/ material at site, erection of equipment /material at site including fabrication, equipment and system testing, commissioning of the entire system both at **Agra New 765KV S/s Site**.
- b) Erection of pipe pylon supports, with pipe hangers and other pipe supports corresponding to HVW Spray system.
- c) Painting of aboveground piping (for hydrant system & HVW spray system in the pump house & switchyard), pipe pylon supports etc. as per customer specification.
- d) Land excavation, laying of underground piping for hydrant/ spray system with wrapping & coating & backfilling.
- e) Laying and termination of power and control cables for the equipment under the scope this specification.
- f) Laying & fixing of cable trays on walls or elsewhere.
- g) All the installations in the switchyard and pump house shall be properly earthed by the contractor to the nearest earthmat riser of the Owner / Purchaser.
- h) The contractor shall arrange all machinery -tools & tackles and consumables required for erection of the system.
- i) Contractor shall ensure that sufficient quantity of commissioning spares is made available for timely completion of commissioning of the system. The contractor shall furnish a list of commissioning spares that will be brought by him. The unused commissioning spares shall be returnable to the Contractor.
- j) Conducting Performance Guarantee tests to the satisfaction of Customer/ Purchaser.
- k) It is the responsibility of the successful Bidder to obtain necessary approval/ clearance from statutory organizations wherever applicable for the equipment/ systems under the scope specified.
- l) After completion of erection and commissioning of the system, the contractor shall train site engineers of Purchaser/Owner so that they are fully conversant with both electrical and mechanical part of the package.
- m) The contractor shall furnish the operation and maintenance manual specifically compiled for each of the sub-stations. The draft O&M manual shall be submitted within 20 weeks after award of contract. The O&M manual shall contain the following information:
- i) Description of the system and equipment with design particulars
  - ii) Instruction for erection.
  - iii) Instruction for operation, maintenance and repair.
  - iv) Recommended inspection practices and inspection schedule.
  - v) Ordering information for all replaceable parts
  - vi) Recommendation for type of lubricants and frequency of lubrication.

<b>Project</b>	<b>765/400KV (UPPTCL) NEW SUBSATATION AT AGRA</b>	<b>TB-376-522-01 Rev 00</b>	
<b>System</b>	<b>FIRE FIGHTING SYSTEM</b>		
<b>Owner</b>	<b>UPPTCL</b>		
<b>Customer</b>	<b>POWER GRID CORPORATION OF INDIA LTD</b>		
<b>Purchaser</b>	<b>BHEL (TRANSMISSION BUSINESS GROUP)</b>		

#### 4.2.2 Civil Works

The following shall be in the scope of Contractor:

- a) Construction of RCC pedestals to support the above ground piping for hydrant & spray system and for pylon supports of HVW spray system outside sump pit, wherever required.
- b) Construction of housing for deluge valve and painting the same on outside & inside. The housing shall have RCC roof.
- c) Minor civil works such as grouting, filling up of crevices/ cut outs etc during installation of equipment shall also be in contractor's scope. Any other damage caused to civil works during ETC work of the equipment/system shall be made good to the original finish by the Contractor at no extra cost to the Purchaser.

#### 4.2.2 Inspection & Testing

All the equipments shall be inspected prior to dispatch in line with relevant IS, approved GTP/ drawing and technical specification.

#### 5.0.0 EXCLUSIONS

- 5.1.0 Supply of power & control cables for the system except for fire detection & alarm system which shall be supplied by contractor.
- 5.2.0 Supply of necessary cable trays for laying power and control cables, wherever required.
- 5.3.0 Supply of GI flat for earthing of equipments is free issue item to contractor. However eathing of all fire fighting equipments shall be done by contractor.
- 5.4.0 Construction of pump house & water storage tank.
- 5.5.0 Construction of equipment foundations inside the pump house. The contractor shall submit foundation details and supply foundation bolts etc. within one month of LOI.
- 5.6.0 Supply of hume pipe at road crossing for firefighting pipes is excluded from contractor's scope. However contractor should provide the details and size of hume pipe in the fire fighting layout.

#### 6.0.0 HANDING & TAKING OVER

It is the responsibility of the Contractor to run and maintain the plant till it is handed over to the owner. Contractor shall assist purchaser to hand over the plant to owner.

#### 7.0.0 UTILITIES AVAILABLE

Construction water and 415 V power shall be available at one point each. Contractor shall be required to make own arrangement for taking supplies from there.

#### 8.0.0 VARIOUS HEADS TO BE QUOTED FOR

- 8.1.0 Based on the above input it is recommended that the bidders shall submit their LUMPSUM offers in the prescribed format only

Sl. No.	Item Description	Quantity	Amount
1.0	Supply of main items pertaining to following:		
	a) Hydrant System	1 Lot	
	b) HVW Spray System	1 Lot	
	c) Fire Detection & Alarm System	1 Lot	
	d) Portable Extinguishers	1 Lot	
	e) Pump house equipments	1 Lot	

<b>Project</b>	<b>765/400KV (UPPTCL) NEW SUBSATATION AT AGRA</b>	<b>TB-376-522-01 Rev 00</b>	
<b>System</b>	<b>FIRE FIGHTING SYSTEM</b>		
<b>Owner</b>	<b>UPPTCL</b>		
<b>Customer</b>	<b>POWER GRID CORPORATION OF INDIA LTD</b>		
<b>Purchaser</b>	<b>BHEL (TRANSMISSION BUSINESS GROUP)</b>		

2.0	Erection, Testing & commissioning of the complete fire protection system	1 Lot	
<b>Total LUMPSUM Price FOR THE PACKAGE</b>			

8.2.0 It may be noted that BOQ furnished by the bidder against main heads as per Table-I in cl. 9.1.0 shall not be considered as limits to scope of supply and ETC. Being a lump sum offer, any other item, which is not specifically mentioned in this specification 'OR' any item not considered by the bidder in his BOQ 'OR' additional quantity of any given item in Bidder's BOQ, which is required for satisfactory operation of the system shall be supplied and erected without any additional cost implication to BHEL/POWERGRID.

8.3.0 Variation in quantities due to change in input by BHEL during contract stage shall be settled on the basis of mutually agreed rates.

#### ANNEXURE- 'A'

#### Cable Sizes being procured by BHEL for Sub-Station

Sl. No.	Item Description	Length (Mtrs)	Remark
<b>1.0</b>	<b>Power Cables (PVC) (1100 V Grade)</b>		<b>Bidder to be furnished the quantity required against the applicable cable size.</b>
A	1 C X 150 SQ. MM AL.		
B	3.5 C X 70 SQ. MM AL.		
C	3.5 C X 35 SQ. MM AL.		
D	4C X 6 SQ.MM AL.		
E	2C X 6 SQ.MM AL.		
F	4C X 16 SQ.MM AL.		
	<b>Power Cables (XLPE) (1100 V Grade)</b>		
G	1 C X 630 SQ. MM AL.		
H	3.5C X 300 SQ.MM AL.		
<b>2.0</b>	<b>Control Cables (Cu)</b>		
A	2C X 2.5 SQ. MM CU.		
B	5C X 2.5 SQ. MM CU.		
C	7C X 2.5 SQ. MM CU.		
D	10C X 2.5 SQ. MM CU.		
E	14C X 2.5 SQ. MM CU.		
F	19C X 2.5 SQ. MM CU.		

<b>Project</b>	<b>765/400KV (UPPTCL) NEW SUBSATATION AT AGRA</b>	<b>TB-376-522-01 Rev 00</b>	
<b>System</b>	<b>FIRE FIGHTING SYSTEM</b>		
<b>Owner</b>	<b>UPPTCL</b>		
<b>Customer</b>	<b>POWER GRID CORPORATION OF INDIA LTD</b>		
<b>Purchaser</b>	<b>BHEL (TRANSMISSION BUSINESS GROUP)</b>		

## SECTION 2 EQUIPMENT SPECIFICATION

Refer the enclosed Powergrid's technical specification (Doc ref: C/ENGG/SPEC/FP Rev-6) for Fire Protection System.

All the requirements pertaining to type, make, quality, testing & inspection of equipments, provisions of control, interlocks, indications, annunciations, alarms etc, as laid down in various clauses of this specification shall be satisfied by the contractor in totality.

**TECHNICAL SPECIFICATION FOR**  
**FIRE PROTECTION SYSTEM**  
**TABLE OF CONTENTS**

<u>Clause No.</u>	<u>Description</u>	<u>Page No.</u>
1.00.00	Intent of Specification	1
2.00.00	Design and construction	2
3.00.00	Tests	14
4.00.00	Spare Parts	16
5.00.00	Horizontal Centrifugal Pumps	16
6.00.00	Diesel Engines	22
7.00.00	Piping, Valves & Specialities	26
8.00.00	Air Vessels	34
9.00.00	Heat detectors/Fire detectors and spray nozzles	35
10.00.00	Portable and Wheel/ Trolley mounted Fire Extinguishers	36
11.00.00	Instruments	38
12.00.00	Electric Motors	41
13.00.00	Battery & Battery chargers	47
14.00.00	Control and Annunciation Panels	49
Appendix-I	P&I for Hydrant & HVW Spray System for 765kV and 400kV Substation	
Appendix-II	Typical Drawings for location of Fire Detectors and Extinguishers	
Appendix-III	Typical Drawings of HVW Spray System for transformer & reactor	
Appendix-IV	Technical Data Sheets	
Appendix-V	List of Approved Vendors	
Appendix-VI	P&I for Hydrant & HVW Spray System for 220kV and 132kV Substation	

**TECHNICAL SPECIFICATION FOR**  
**FIRE PROTECTION SYSTEM**

**1.00.00 INTENT OF SPECIFICATION**

This section covers the design and performance requirements of the following types of fire protection systems;

- a. Hydrant System
- b. High Velocity Water (H.V.W) Spray System
- c. Fire Detection and alarm System
- d. Portable Fire Extinguishers
- e. Wheel/ Trolley mounted Fire Extinguishers

1.00.01 It is not the intent to completely specify all details of design and construction. Nevertheless, the system design and equipment shall conform in all respects to high standard of engineering, design and workmanship and shall be capable of performing in continuous commercial operation in a manner acceptable to the Owner. The system design shall also conform to TAC/ NFPA norms.

1.00.02 The scope of work include complete earthwork (i.e. excavation, backfilling etc.) for the entire buried piping for the system, valve pits and pipe supports for buried, entrenched and overground piping.

1.00.03 **The equipment offered shall comply with the relevant Indian Standards unless specified otherwise.** The equipment conforming to any other approved international standards shall meet the requirement called for in the latest revision of relevant Indian Standard or shall be superior. The Deluge valves, HVW spray nozzles & quartzoid bulb detectors shall have the approval of any of the following agencies;

- a. UL of USA.
- b. F M of USA
- c. LPCB of UK or
- d. VDS of Germany,

1.00.04 Ambient temperature for design of all equipment shall be considered as 50°C.

1.00.05 **The piping and instruments diagram for Hydrant and HVW spray system for 765kV/400kV substations and for 220kV&132kV substation is**

enclosed at Appendix-I and Appendix-VI respectively. The successful bidder shall prepare detailed layout and piping drawing based on this drawing and other drawings such as road, drainage, cable trench, switch yard layout, etc. as furnished by the Employer during detailed engineering.

The typical drawings for location of fire detectors and fire extinguishers in control cum administrative building attached in Appendix-II with this section shall be followed for execution.

- 1.00.06 Equipment under the fire protection system should be supplied from the suppliers approved by POWERGRID (A list of approved vendors is enclosed at Appendix-V). All equipment shall conform to the data sheets attached in Appendix-IV and/or relevant subsections/clauses of this specification. In case of contradiction between data specification sheets and relevant subsections/clauses, then stipulations of the data sheets will prevail.

## 2.00.00 DESIGN AND CONSTRUCTION

### 2.01.00 Hydrant System

Hydrant system of fire protection essentially consists of a large network of pipe, both under ground and over ground which feeds pressurised water to a number of hydrant valves, indoor (if applicable) as well as outdoor. These hydrant valves are located at strategic locations near buildings, Transformers and Reactors. Hose pipes of suitable length and fitted with standard accessories like branch pipes, nozzles etc., are kept in Hose boxes. In case of emergency, these hoses are coupled to the respective hydrant valves through instantaneous couplings and jet of water is directed on the equipment on fire. Hydrant protection shall be provided for the following in all substations of voltage levels 132kV and above (This is not applicable for extension of existing 220kV and 132kV substations where Hydrant system is not available). At least one hydrant post shall be provided for every 60m of external wall measurement of buildings.

- a) Control room building
- b) L.T. Transformer area.
- c) Fire Fighting pump House.
- d) Stores
- e) Transformers

## f) Shunt Reactors/ Bus Reactors.

2.01.01 A warning plate shall be placed near the hydrant points for the transformers and reactors substations to clearly indicate that water shall be sprayed only after ensuring that the power to the transformer/ reactor which is on fire is switched off and there are no live parts within 20metres of distance from the personnel using the hydrant.

2.02.00. **HIGH VELOCITY WATER (H.V.W) SPRAY SYSTEM**

H.V.W. spray type fire protection essentially consists of a network of projectors and an array of heat detectors around the Transformer/Reactor to be protected. On operation of one or more of heat detectors, Water under pressure is directed to the projector network through a Deluge valve from the pipe network laid for this system. **This shall be provided for transformers and reactors in all 132kV & above substations (This is not applicable for extension of existing 220kV and 132kV substations where HVWS system is not available).** Wet detection initiation system shall be employed for automatic operation.

The system shall be designed in such a way that the same can be extended to protect additional Transformer/ Reactor to be installed in future. However, for the purpose of design it shall be assumed that only one Transformer/ Reactor will be on fire. **The main header pipe size in the yard shall be 250mmNB (for 400kV and above level substations) and 200mmNB(for 220kV & 132kV substations). Branch to the equipment (shall not be more than 20metres length) shall be of the same size as of deluge valve.**

2.02.01 The Electrical clearance between the Emulsifier system pipe work and live parts of the protected equipment shall not be less than the values given below :

1.	765 kV bushing	4900 mm
2.	420 kV bushing	3500 mm
3.	245 kV bushing	2150 mm
4.	145 kV bushing	1300 mm
5.	52 kV bushing	630 mm
6.	36 kV bushing	320 mm

2.02.02 System shall be designed in such a way that the Water pressure available at any spray nozzle shall be between 3.5bar and 5.0bar and shall be demonstrated through hydraulic calculations. Water shall be applied at a minimum rate of 10.2 LPM/M<sup>2</sup> of the surface area of the transformer / Reactor including radiator, conservator, oil pipes, bushing turrets, etc. (including bottom surface for transformer). The nozzle arrangement shall ensure direct impingement of water on all exterior surfaces of transformer tank, bushing turrets, conservator and oil pipes, except underneath the transformer, where horizontal spray may be provided. Typical drawings of HVW spray system of a transformer and a reactor is enclosed at Annexure-III for reference.

### 2.02.03 **Deluge Valve**

Deluge Valve shall be water pressure operated manual reset type. The Deluge valve shall be closed water tight when water pressure in the heat detector pipe work is healthy and the entire pipe work shall be charged with water under pressure upto the inlet of the Deluge valve. On fall of water pressure due to opening of one or more heat detectors, the valve shall open and water shall rush to the spray water network through the open Deluge valve. The valves shall be manually reset to initial position after completion of operation. Each Deluge Valve shall be provided with a water motor gong which shall sound an alarm when water after passing through the Deluge valve, is tapped through the water motor.

Each Deluge valve shall be provided with a local panel with provision of opening of Deluge valve from local and remote from control room/ remote centre. In addition to this, each valve shall be provided with local operation latch.

Deluge valves of 100mmNB size shall be used if the flow requirement is  $\leq 200\text{m}^3/\text{hr}$  and 150mmNB size shall be used for flow requirement  $>200\text{m}^3/\text{hr}$ .

Test valves shall simulate the operation of Deluge valves and shall be of quick opening type. The general construction shall conform to requirements under clause no.7.00.00 for piping, valves and specialities.

### 2.02.04 **High Velocity Spray Nozzles (Projectors)**

High velocity spray system shall be designed and installed to discharge water in the form of a conical spray consisting of droplets of water travelling at high velocity, which shall strike the burning surface with sufficient impact to ensure the formation of an emulsion. At the same time the spray shall efficiently cut off oxygen supply and provide sufficient cooling.

2.02.05 Minimum set point of the heat detectors used in the HVW spray system shall be 79°C. The optimum rating shall, however, be selected by the Bidder, keeping in mind the maximum and minimum temperature attained at site.

2.03.00 **Fire Detection and alarm System**

This system shall be provided for control room building and Switchyard panel rooms of substations.

2.03.01 Suitable fire detection system using smoke detectors and/or heat detectors shall be provided for the entire building, including corridor and toilets. Fire detectors shall be located at strategic locations in various rooms of the building. Each Switchyard panel room shall be considered a separate zone. Adequate number of extra zones shall be provided for Switchyard panel rooms for future bays identified in Single line diagram of the substation. The operation of any of the fire detectors/ manual call point should result in the following;

1. A visual signal exhibited in the annunciation panels indicating the area where the fire is detected.
2. An audible alarm sounded in the panel, and
3. An external audible alarm sounded in the building, location of which shall be decided during detailed engineering.
4. If the zone comprises of more than one room, a visual signal shall be exhibited on the outer wall of each room.

2.03.02 Each zone shall be provided with two zone cards in the panel so that system will remain healthy even if one of the cards becomes defective.

2.03.03 Coverage area of each smoke detector shall not be more than 80 m<sup>2</sup> and that of heat detectors shall not be more than 40 m<sup>2</sup>. Ionisation type smoke detectors shall be provided in all areas except pantry room where heat detectors shall be provided. If a detector is concealed, a remote visual indication of its operation shall be provided. Manual call points (Break glass Alarm Stations) shall be provided at strategic locations in the control room building. All cabling shall be done through concealed conduits.

2.03.04 Cables used should be exclusively for fire detection and alarm system and shall be 2Cx1.5sq.mm Cu. cables. Un-armoured PVC insulated FR cables conforming to IS 1554 (Part 1) shall be used.

2.04.00 Portable and Wheel/ Trolley mounted Fire Extinguishers

#### 2.04.01 Portable Fire Extinguishers

Adequate number of portable fire extinguishers of pressurised water, dry chemical powder, and Carbon dioxide type shall be provided in suitable locations in control room building and FFPH building as indicated in the drawing. In addition to this one (1) CO2 type fire extinguisher of 4.5kg capacity shall be provided for each Switchyard panel room. These extinguishers will be used during the early phases of fire to prevent its spread and costly damage.

The design, construction & testing of portable fire extinguishers shall meet the requirements as per clause 10.00.00.

#### 2.04.02 Wheel/ Trolley mounted Fire Extinguishers

Wheel/Trolley mounted Mechanical foam type fire extinguishers of 50litre capacity, conforming to IS:13386, shall be provided for the protection of the following:

1. Transformers and reactors in 220kV and 132 kV substations **where Hydrant/HVWS system is not available.** Two (2) nos. for each 220kV or 132kV transformer and reactor.
2. LT transformers in all substations. One (1) no. for each **LT** transformer.

The design, construction & testing of Mechanical foam type 50 litre capacity shall meet the requirements of relevant IS Codes and clause 10.00.00 of this specification.

#### 2.05.00 Water Supply System

For 400kV and above level substations water for hydrant & HVW system shall be supplied by one electrical motor driven pump of rated capacity 410m<sup>3</sup>/hr. at 70MWC head **& for 220kV and 132kV substations water for hydrant & HVWS system shall be supplied by one electrical motor driven pump of rated capacity 273m<sup>3</sup>/hr. at 70MWC head,** with another pump of same capacity , driven by diesel engine, shall be used as standby. Water storage tank with two compartments of adequate capacity shall be provided. Pumps shall work under positive suction head. Annunciations of the hydrant & HVW spray systems shall be provided in fire water pump house and repeated in control room. **Provision for sending data to remote control centre shall also be available.**

The outdoor piping for the system in general shall be laid above ground on concrete pedestals with proper supporting arrangement. However, at

road/rail crossings, in front/access of buildings, places where movement of cranes/vehicles is expected and at any other place where above ground piping is not advisable, the pipes shall be laid underground. Such locations shall be finalised during detailed engineering.

The whole system will be kept pressurised by providing combination of air vessel and jockey pump of 10.8M<sup>3</sup>/hr. capacity at 80MWC. The capacity of air vessel shall not be less than 3m<sup>3</sup>. Minor leakage will be met by Jockey pump. One additional jockey pump shall be provided as standby. All pumps shall be of horizontal centrifugal type. Pumps and air vessel with all auxiliary equipment will be located in firewater pump house. A pressure relief valve of suitable rating shall be provided in water header to release excess pressure due to atmospheric temperature variations.

Operation of all the pumps shall be automatic and pumps shall be brought into operation at preset pressure. Fire pumps shall only be stopped manually. Manual start/stop provision shall be provided in local control panel.

- 2.05.01 The general design of the fire fighting pump sets shall meet the requirements under clauses no.5.00.00 for Horizontal centrifugal pumps, no.6.00.00 for Diesel engines and no.12.00.00 for Electrical motors.
- 2.05.02 Each pump shall be provided with a nameplate indicating suction lift/delivery head, capacity and number of revolutions per minute.
- 2.05.03 Design, construction, erection, testing and trial operation of piping, valves, strainers, hydrant valves, hoses, nozzles, branch pipes, hose boxes, expansion joints etc. shall conform to the requirements of clause no. 7.00.00.
- 2.06.00 **Instrumentation and Control System**
- 2.06.01 All instruments like pressure indicators, differential pressure indicators, pressure switches, level indicators, level switches, temperature indicators, alarms and all other instruments and panels as indicated in the specification and drawings and those needed for safe and efficient operation of the whole system shall be furnished according to the requirements of clause 11.00.00. Pump running/ fails to start signal shall be taken from the pressure switch immediately after the discharge of the pump.
- 2.06.02 **Control Panel**

Power feeder for motors will be from switchgear board located in control

building but control supply for all local control panels, annunciation panels, battery charger units, space heaters etc. shall be fed from the AC and DC distribution boards located in pump house. These AC & DC distribution boards will be fed from the switchgears and DCDBs located in control building.

a) Panel for motor driven fire water pump

The panel shall be provided with the following:

- |    |  |       |
|----|--|-------|
| 1. | TPN switch   | 1 No. |
| 2. | <b>Auto/manual selection facility</b>              |       |
| 3. | <b>Start/Stop facility</b><br>with indication lamp | 1 Set |
| 4. | DOL starter with<br>thermal O/L relay              | 1 Set |
| 5. | Indicating lamp showing<br>power ON                | 1 Set |
| 6. | Indication lamp with drive<br>ON/OF                | 1 Set |
| 7. | Indication lamp showing<br>Motor Trip              | 1 No. |

**Additional provisions shall be made for controlling the following from the remote control centre:**

**1. Auto/manual selection facility**

**2. Start/Stop facility**

Main power cable from breaker feeder of main switchboard shall be terminated in this panel and another cable shall emanate from this panel which shall be terminated at motor terminals.

b) Panel for Two nos. Jockey Pump 1No.

The panel shall be provided with the following :

- |    |                                   |                     |
|----|-----------------------------------|---------------------|
| 1. | Fuse-switch unit for Jockey pumps | 1 Set for each pump |
|----|-----------------------------------|---------------------|

- |    |  |                     |
|----|--|---------------------|
| 2. | <b>Auto/manual selection facility for each pump</b>  |                     |
| 3. | Selector switch for selecting either jockey pump   | 1 No.               |
| 4. | D.O.L. starter with overload relay self-resetting type, for all the drives.                                | 1 No. each          |
| 5. | Start/stop push button for Jockey Pump with indication lamp with pad-locking arrangements in stop position | 1 Set for each pump |
| 6. | Indication lamp for trip indication  | 1 No. each for pump |

**Additional provisions shall be made for controlling the following from the remote control centre:**

**1. Auto/manual selection facility for each pump.**

- |    |   |       |
|----|---|-------|
| c) | Panel for 2 Nos. battery charger & Diesel Engine driven fire water pump | 1 No. |
|----|---|-------|

The panel shall be provided with the following :

- |    |   |            |
|----|---|------------|
| 1. | <b>Auto/Manual selection facility</b> for Diesel Engine driven pump | 1 No.      |
| 2. | <b>Start/Stop facility</b> with indication lamp                     | 1 Set      |
| 3. | Indicating lamp showing drive ON/OFF                                | 1 Set      |
| 4. | D.C. Voltmeter/Ammeter in the battery charger circuit               | 1 No. each |
| 5. | Battery charger will be as per specification described              | 1 Set      |
| 6. | Selector switch for selecting                                       | 1 No.      |

either of battery chargers  
for the battery sets.

- |    |   |       |
|----|---|-------|
| 7. | Selector switch for selecting either set of batteries for Diesel engine starting. | 1No.  |
| 8. | Selector switch for boost charging/Trickle charging of battery set.               | 1 Set |

**Additional provisions shall be made for controlling the following from the remote control centre:**

**1. Manual Start/Stop of Diesel Engine**

- d) Individual local control panel is to be considered for each transformer/ Reactor deluge system wherever these equipment are envisaged. This panel shall contain push buttons with indicating lamps for spray ON/OFF operation in the valve operation circuit. Push buttons shall be concealed behind glass covers, which shall be broken to operate the buttons. Provision shall be made in the panel for the field signal for the annunciations such as spray ON and fire in the Transformer/Reactor. A signal for spray ON shall also be provided in the control room fire alarm panel for employer's event logger. Remote operation facility to open the Deluge valve from control room/ remote centre shall also be provided.

**2.06.03 Annunciation Panels**

**a) Location: Fire Water Pump House**

- i) Indicating lamps showing power supply "ON".
- ii) Annunciation windows complete with buttons. Details are as follows:

Sl.No.	Description	Number
1.	Electric motor driven fire water pump running	1
2.	Electric motor driven fire water pump fails to start	1
3.	Diesel engine driven fire water pump running.	1
4.	Diesel engine driven water pump fails	1

	to start	
5.	Jockey pump-1 running	1
6.	Jockey pump-1 fails to start	1
7.	Jockey pump-2 running	1
8.	Jockey pump-2 fails to start	1
9.	Fire in Transformer/ Reactor	1 for each equipment
10.	Deluge system operating for Transformer/Reactor	1 for each equipment
11.	Header pressure low	1
12.	Fire in smoke detection system zone (Common Fire Signal)	1
13.	Water storage tank water level low	2
14.	High speed diesel tank level low	1
15.	Spare	10

b) **Location: Substation Control Room**

- i) Indication lamp showing power supply 'ON'
- ii) Provision shall be made in the panel for a signal for spray ON for each Transformer/Reactor for owner's use for event logger.
- iii) Each Switchyard panel room shall be considered as separate zone for fire detection and alarm system.
- iv) Following annunciations shall be provided.

Sl.No.	Description	Number
--------	-------------	--------

1.	Fire in Transformer/ Reactor	1 for each equipment
2.	Diesel engine driven fire water pump in operation	1
3.	Motor driven fire water pump in operation	1
4.	Jockey pump in operation	1
5.	Fire fighting Water storage tank level Low	2
6.	Fire/Fault (zone alarm module)	1+1(duplicate) For each zone as applicable
7.	Spare windows complete in all respect, with relays	10
8.	Spare zone alarm modules	Number of future A/c Kiosks required for the bays identified as per SLD

c) Each annunciation panel shall be provided with a hooter. **A hooter in parallel to the hooter in fire panel shall be provided in the security room of substation for alert in case of fire.**

d) Indication for fault in respective areas shall also be provided. Each zone alarm module shall exhibit 'FIRE' and 'FAULT' conditions separately.

**e) Provision for sending data to Remote Control Unit for the following**

**(i) Fire in Switchyard Panel Room (Switchyard Panel room shall be considered as separate zone for fire detection and alarm system).** Present and future scope

**(ii) Fire in Transformer/Reactor (1 for each equipment)** Present and future scope

**(iii) Diesel engine driven fire water pump in operation.**

**(iv) Motor driven fire water pump in operation**

**(v) Fire/Fault in Control Room.**

**(vi) Water Storage tank level (low and very low for each storage tank).**

**(vii) High Speed Diesel tank level (low & very low)**

**(viii) AC Mains Supply Healthy/Fail for Main Pump & Jockey Pump**

**(ix) DC Control Supply Healthy/Fail for Main Pump & Jockey Pump**

**(x) DC Control Supply Healthy/Fail for Diesel Engine driven pump.**

2.06.04 The control and interlock system for the fire protection system shall meet the following requirements:

**1. Electric Motor Driven Fire water Pump**

Pump should start automatically when the System header pressure is low.

Pump should be stopped manually only. Pump should also be started manually if required from local control panel.

**2. Diesel Engine Driven Standby Pump**

The pump should automatically start under any of the following conditions:

- a) System Header pressure low.
- b) Electric motor operated fire water pump fails to start.

Pump should be stopped manually only. Pump should also be started manually if required from the local control panel. The battery set which is connected for starting of Diesel engine shall not be subjected to boost charge.

**3. Jockey Pump**

It shall be possible to select any one of the Jockey pumps as main and the other as standby. Main Jockey pump shall start automatically when water pressure in header falls below the set value. If the main jockey pump fails to start then the standby should start. Jockey pump shall stop automatically when the pressure is restored to its normal value.

Manual starting/stopping shall be possible from the local control

panel.

### 3.00.00 TESTS

#### 3.01.00 Shop Tests

3.01.01 Shop tests of all major equipment centrifugal pumps, diesel engines, electrical drive motors, piping, valves and specialties, pressure and storage vessels, MCC, electrical panels, controls, instrumentation etc. shall be conducted as specified in various clauses and as per applicable standards/codes.

3.01.02 Shop tests shall include all tests to be carried out at Contractor's works, works of his sub-contractor and at works where raw materials supplied for manufacture of equipment are fabricated. The tests to be carried out shall include but not be limited to the tests described as follows :

- a) Materials analysis and testing.
- b) Hydrostatic pressure test of all pressure parts, piping, etc.
- c) Dimensional and visual check.
- d) Balancing test of rotating components.
- e) Response of heat/smoke detectors.
- f) Performance characteristics of HVW spray nozzles (projectors).
- g) Flow rate and operational test on Flow control valves.
- h) Operational test of alarm valve (water-motor gang).
- i) Calibration tests on instruments and tests on control panel.
- j) Destruction/burst tests on 2% or minimum one (1) no. of hoses and portable type fire extinguishers for each type as applicable. Any fraction number shall be counted as next higher integer.
- k) Performance test on fire extinguishers as required in the code.

3.01.03 In the absence of any Code/Standard, equipment shall be tested as per mutually agreed procedure between the supplier and the Employer.

3.01.04 A comprehensive visual and functional check for panels would be conducted and will include a thorough check up of panel dimensions,

material of construction, panel finish, compliance with tubing and wiring specifications, quality of workmanship, proper tagging & locations of instruments/accessories. The wiring check shall be complete point to point ring out and check for agreement with installation drawings and equipment vendor prints of the complete system and an inspection of all field connection terminals and levelling.

3.01.05 All test certificates and reports shall be submitted to the Employer for approval.

3.01.06 The Employer's representative shall be given full access to all tests. The manufacturer shall inform the Employer allowing adequate time so that, if the Employer so desires, his representatives can witness the test.

### 3.02.00 **Pre-commissioning Tests**

#### 3.02.01 **General**

- a) All piping and valves, after installation will be tested hydraulically at a pressure of 16kg/cm<sup>2</sup> for a period of 30 minutes to check against leak tightness.
- b) All manually operated valves/gates shall be operated throughout 100% of the travel and these should function without any trouble whatsoever, to the satisfaction of the Employer.
- c) All pumps shall be run with the specified fluid from shut off condition to valve wide open condition. Head developed will be checked from the discharge pressure gauge reading. During the test, the pumps and drives shall run smoothly without any undue vibration, leakage through gland, temperature rise in the bearing parts, noise, flow pulsation etc.
- d) All pressure vessels should be tested hydraulically at the specified test pressure, singly or in the system.
- e) Painting shall be checked by dry type thickness gauges.
- f) Visual check on all structural components, welding, painting etc. and if doubt arises, these will be tested again.
- g) All test instruments and equipment shall be furnished by the Contractor to the satisfaction of the Employer.
- h) Automatic starting of all the fire pumps by operating the test valves.

- i) Automatic operation of the Jockey pump
- j) Operation of the Deluge valve by breaking a detector as well as manual and remote operation of the deluge valve.
- k) Operation of entire annunciation system.

Replacement of fused/damaged quartzoid bulb detectors during the test shall be responsibility of contractor.

- 3.02.02 After erection at site, the complete HVW spray protection and hydrant system shall be subject to tests to show satisfactory performance for which detailed procedure shall be submitted for Employer's approval.

Full flow tests with water shall be done for the system piping as a means of checking the nozzle layout, discharge pattern and coverage, any obstructions and determination of relation between design criteria and actual performance, also to ensure against clogging of the smaller piping and the discharge devices by foreign matter carried by the water.

Rigidity of pipe supports shall also be checked during the water flow.

- 3.02.03 All the detectors installed shall be tested for actuation by bringing a suitable source of heat/smoke near the detector and creating a stream of hot air/ smoke over the detector. The exact procedure of this test shall be detailed out by the Employer to the successful Bidder.

#### 4.00.00 **SPARE PARTS**

The Contractor shall indicate in his scope of supply all the mandatory spares in the relevant schedules. The list of mandatory spares is indicated in 'Section - Projects'.

#### 5.00.00 **HORIZONTAL CENTRIFUGAL PUMPS**

This clause covers the design, performance, manufacturing, construction features and testing of horizontal centrifugal pumps used for the purpose of fire fighting.

- 5.01.00 The materials of the various components shall conform to the applicable IS/BS/ASTM/DIN Standards.

- 5.01.01 In case of any contradiction with the aforesaid standards and the stipulations as per the technical specification as specified hereinafter, the stipulations of the technical specification shall prevail.

#### 5.02.00 **General Performance Requirements**

- 5.02.01 The pump set shall be suitable for continuous operation at any point within the "Range of operation".
- 5.02.02 Pumps shall have a continuously rising head capacity characteristics from the specified duty point towards shut off point, the maximum being at shut off.
- 5.02.03 Pumps shall be capable of furnishing not less than 150% of rated capacity at a head of not less than 65% of the rated head. The shut off head shall not exceed 120% of rated head. Range of operation shall be 20% of rated flow to 150% of rated flow.
- 5.02.04 The pump-motor set shall be designed in such a way that there is no damage due to the reverse flow through the pump which may occur due to any mal-operation of the system.

5.02.05 **Drive Rating**

The drive rating shall not be less than the maximum power requirement at any point within the "Range of Operation" specified.

During starting under reverse flow condition, the motor shall be capable of bringing the pump to rated speed at normal direction with 90% rated voltage at motor terminals.

- 5.02.06 Pump set along with its drive shall run smooth without undue noise and vibration. Acceptable peak to peak vibration limits shall generally be guided by Hydraulic Institute Standards.
- 5.02.07 The Contractor under this specification shall assume full responsibility in the operation of the pump and drive as one unit.

5.03.00 **Design & Construction**

- 5.03.01 Pump casing may be axially or radially split. The casing shall be designed to withstand the maximum pressure developed by the pump at the pumping temperature.
- 5.03.02 Pump casing shall be provided with adequate number of vent and priming connections with valves, unless the pump is made self-venting & priming. Casing drain, as required, shall be provided complete with drain valves.
- 5.03.03 Under certain conditions, the pump casing nozzles will be subjected to reactions from external piping. Pump design must ensure that the nozzles are capable of withstanding external reactions not less than those specified in API-610.
- 5.03.04 Pump shall preferably be of such construction that it is possible to

service the internals of the pump without disturbing suction and discharge piping connections.

#### 5.03.05 **Impeller**

The impeller shall be secured to the shaft and shall be retained against circumferential movement by keying, pinning or lock rings. On pumps with overhung shaft impellers shall be secured to the shaft by an additional locknut or cap screw. All screwed fasteners shall tighten in the direction of normal rotation.

#### 5.03.06 **Wearing Rings**

Replaceable type wearing rings shall be furnished to prevent damage to impeller and casing. Suitable method of locking the wearing ring shall be used.

#### 5.03.07 **Shaft**

Shaft size selected shall take into consideration the critical speed, which shall be at least 20% away from the operating speed. The critical speed shall also be atleast 10% away from runaway speed.

#### 5.03.08 **Shaft Sleeves**

Renewable type fine finished shaft sleeves shall be provided at the stuffing boxes/mechanical seals. Length of the shaft sleeves must extend beyond the outer faces of gland packing or seal and plate so as to distinguish between the leakage between shaft & shaft sleeve and that past the seals/gland.

5.03.09 Shaft sleeves shall be securely fastened to the shaft to prevent any leakage or loosening. Shaft and shaft sleeve assembly should ensure concentric rotation.

#### 5.03.10 **Bearings**

Bearings of adequate design shall be furnished for taking the entire pump load arising from all probable conditions of continuous operation throughout its "Range of Operation" and also at the shut-off condition. The bearing shall be designed on the basis of 20,000 working hours minimum for the load corresponding to the duty point.

Bearings shall be easily accessible without disturbing the pump assembly. A drain plug shall be provided at the bottom of each bearing housing.

#### 5.03.11 **Stuffing Boxes**

Stuffing box design shall permit replacement of packing without

removing any part other than the gland. Stuffing boxes shall be sealed/cooled by the fluid being pumped and necessary piping, fittings, valves, instruments, etc. shall form an integral part of the pump assembly.

#### 5.03.12 **Shaft Couplings**

All shafts shall be connected with adequately sized flexible couplings of suitable design. Necessary guards shall be provided for the couplings.

#### 5.03.13 **Base Plates & Sole Plate**

A common base plate mounting both for the pump and drive shall be furnished.

The base plate shall be of rigid construction, suitably ribbed and reinforced. Base plate and pump supports shall be so constructed and the pumping unit so mounted as to minimise misalignment caused by mechanical forces such as normal piping strain, hydraulic piping thrust etc. Suitable drain taps and drip lip shall be provided.

#### 5.03.14 **Material of Construction**

All materials used for pump construction shall be of tested quality. Material of construction of the major parts of the pumps shall be as given below :

a)	Casing	Casting Grade FG: 260 of IS 210
b)	Impeller	Bronze Grade LTB 2 of IS:318
c)	Wearing ring	Bronze Grade LTB 2 of IS:318
d)	Shaft	Grade 40C8 of IS 1570 (Part 2, section 1.): 1979.
e)	Shaft sleeve	Bronze Grade LTB 2 of IS:318 or Chrome steel 07Cr13 of IS 1570 (part 5) :1985.
f)	Stuffing box	2.5% Nickel CI Grade FG 260 of IS:210
g)	Gland	--- do ---

#### 5.03.15 **Balancing**

All rotating components shall be statically and dynamically balanced at

shop.

5.03.16 All the components of pumps of identical parameters supplied under this specification shall be interchangeable.

5.04.00 **Tests and Inspection**

5.04.01 The manufacturer shall conduct all routine tests required to ensure that the equipment furnished conform to the requirements of this specification and are in compliance with the requirements of applicable Codes and Standards. The particulars of the proposed tests and the procedures for the tests shall be submitted to the Employer/Engineer for approval before conducting the tests.

5.04.02 Where stage inspection is to be witnessed by Employer, in addition to above, the Bidder shall submit to the Employer/Engineer at the beginning of the contract, the detailed PERT-Chart showing the manufacturing programme and indicating the period where Employer or his authorised inspecting agency are required at the shop.

5.04.03 **Material of Construction**

All materials used for pump construction shall be of tested quality. Materials shall be tested as per the relevant standards and test certificates shall be made available to the Employer/Engineer.

5.04.04 Where stage inspection is to be witnessed by Employer, all material test certificates shall be correlated and verified with the actual material used for construction before starting fabrication, by Employer's Inspector who shall stamp the material. In case mill test certificates for the material are not available, the Contractor shall carry out physical and chemical tests at his own cost from a testing agency approved by the Employer, as per the requirements of specified material standard. The samples for physical and chemical tests shall be drawn up in presence of Employer's inspector who shall also witness the tests.

5.04.05 Shaft shall be subjected to 100% ultrasonic test and machined portion of the impeller shall be subject to 100% DP test. On finished shaft DP test will also be carried out.

5.04.06 **Hydraulic test at shop**

All pressure parts shall be subjected to hydraulic testing at a pressure of 150% of maximum pressure generated by the pump at rated speed or 200% of total dynamic head whichever is higher, for a period not less than one (1) hour.

5.04.07 **Performance test at shop**

Pumps shall be subjected to routine tests to determine the performance of the pumps. These tests shall be conducted in presence of

Employer/Engineer's representative as per the requirements of the Hydraulic Institute Standards/ASME Power Test Code PTC 8.2/BS-599/I.S.S., latest edition. Routine tests shall be done on all the pumps.

- 5.04.08 Performance tests shall be conducted to cover the entire range of operation of the pumps. These shall be carried out to span 150% of rated capacity upto pump shut-off condition. A minimum of five combinations of head and capacity are to be achieved during testing to establish the performance curves, including the design capacity point and the two extremities of the Range of operation specified.
- 5.04.09 Tests shall preferably be conducted alongwith the actual drives being supplied.
- 5.04.10 The Bidders shall submit in his proposal the facilities available at his works to conduct performance testing. If because of limitations of available facilities, a reduced speed test or model test has to be resorted to establish pump performance, the same has to be highlighted in the offer.
- 5.04.11 In case of model testing, the stipulations of latest edition of Hydraulic Institute Standards shall be binding. Prototype or model tests, however, shall be conducted with the suction condition identical to the field conditions i.e. sigma values of prototype and model is to be kept same.
- 5.04.12 Prior to conducting model testing, calculations establishing model parameters, sizes and test procedure will be submitted to Employer/Engineer for approval.
- 5.04.13 All rotating components of the pumps shall be subjected to static and dynamic balancing tests.
- 5.04.14 The Employer or his authorised representative shall have full access to all tests. Prior to performance tests, the Contractor shall intimate the Employer allowing adequate time so that if the Employer so desires, his representative can witness the test.
- 5.04.15 Report and test certificates of the above tests shall be submitted to the Employer/Engineer for approval.
- 5.04.16 **Pre commissioning tests.**

After installation, pumps offered may be subjected to testing at field also by Employer. If the performances at field are not found to meet the requirement, then the equipment shall be rectified by the Contractor without any extra cost. Prior to performance testing, the procedure for such tests will be mutually agreed between Employer and Contractor. The Contractor shall furnish all necessary instruments, accessories and personnel for testing. Prior to testing, the calibration curves of all instruments and permissible tolerance limit of instruments shall be mutually agreed upon.

## 6.00.00 DIESEL ENGINES

This Clause covers the design, performance, manufacturing construction features and testing of compression ignition diesel engines, used primarily for driving centrifugal pumps, used for the purpose of fire fighting.

### 6.01.00 Design and Construction

#### General

6.01.01 The diesel engine shall be of multicylinder type four-stroke cycle with mechanical (airless) injection, cold starting type.

6.01.02 The continuous engine brake horse power rating (after accounting for all auxiliary power consumption) at the site conditions shall be atleast 20% greater than the requirement at the duty point of pump at rated RPM and in no case, less than the maximum power requirement at any condition of operation of pump.

6.01.03 Reference conditions for rated output of engine shall be as per IS:10000, part II or ISO:3046, part I.

6.01.04 The engine shall be designed with regard to ease of maintenance, repair, cleaning and inspection.

6.01.05 All parts subjected to substantial temperature changes shall be designed and supported to permit free expansion and contraction without resulting in leakage, harmful distortion or misalignment.

#### 6.01.06 Starting

The engine shall be capable of both automatic and manual start. The normal mode of starting is automatic but in the event of failure of automatic start or at the discretion of the operator, the engine can be started manually from the LCP.

Since the fire pumping unit driven by the diesel engine is not required to run continuously for long periods and the operation will not be frequent, special features shall be built into the engine to allow it to start within a very short period against full load even if it has remained idle for a considerable period.

6.01.07 If provision for manual start (cranking) is provided, all controls/mechanisms, which have to be operated during the starting process, shall be within easy reach of the operator.

6.01.08 Automatic cranking shall be effected by a D.C. motor having high starting torque to overcome full engine compression. Starting power will

be supplied from either of the two (2) sets of storage batteries. The automatic starting arrangement shall include a 'Repeat Start' feature for 3 attempts. The battery capacity shall be adequate for 3 (three) consecutive starts without recharging with a cold engine under full compression.

- 6.01.09 The batteries shall be used exclusively for starting the diesel engine and be kept fully charged all the time in position. Arrangement for both trickle and booster charge shall be provided.

Diesel engine shall be provided with two (2) battery charger units of air-cooled design. The charger unit shall be capable of charging one (1) set of battery at a time. Provision shall, however, be made so that any one of the charger units can be utilised for charging either of the two (2) batteries.

- 6.01.10 For detail design of battery and battery charger, sub-section Electrical may be referred to.

6.01.11 **Governing System:**

The engine shall be fitted with a speed control device, which will control the speed under all conditions of load.

- 6.01.12 The governor shall offer following features:

- a) Engine should be provided with an adjustable governor capable of regulating engine speed within 5% of its rated speed under any condition of load between shut-off and maximum load conditions of the pumps. The governor shall be set to maintain rated pump speed at maximum pump load.
- b) Engine shall be provided with an over speed shut-down device. It shall be arranged to shut-down the engine at a speed approximately 20% above rated engine speed and for manual reset, such that the automatic engine controller will continue to show an over speed signal until the device is manually reset to normal operating position (Vol.II, NFPA, 1978).

- 6.01.13 The governor shall be suitable for operation without external power supply.

6.01.14 **Fuel System**

The diesel engine will run on High Speed Diesel.

- 6.01.15 The engine shall be provided with fuel oil tank of 250 litres capacity. The fuel oil tank shall preferably be mounted near the engine. No fuel oil tank will be provided by the Employer.

- 6.01.16 The fuel oil tank shall be of welded steel constructed to relevant standards for mild steel drums. The outlet of the tank shall be above the inlet of fuel injection pump of the diesel engine to ensure adequate pressure at suction of injection pump.
- 6.01.17 The fuel oil tank shall be designed in such a way that the sludge and sediment settles down to the tank bottom and is not carried to the injection pump. A small sump shall be provided and fitted with drain plug to take out sludge/sediment and to drain oil. Adequate hand holes (greater than 80 mm size) shall be provided to facilitate maintenance.
- 6.01.18 Pipeline carrying fuel oil shall be gradually sloped from the tank to the injection pump. Any valve in the fuel feed pipe between the fuel tank and the engine shall be placed adjacent to the tank and it shall be locked in the open position. A filter shall be incorporated in this pipeline, in addition to other filters in the fuel oil system. Pipe joints shall not be soldered and plastic tubing shall not be used. Reinforced flexible pipes may also be used.
- 6.01.19 The complete fuel oil system shall be designed to avoid any air pocket in any part of the pipe work, fuel pump, sprayers/injectors, filter system etc. No air relief cock is permitted. However, where air relief is essential, plugs may be used.
- 6.01.20 A manual fuel pump shall be provided for priming and releasing of air from the fuel pipelines.

6.01.21 **Lubricating Oil System**

Automatic pressure lubrication shall be provided by a pump driven by the crank shaft, taking suction from a sump and delivering pressurised oil through cooler and fine mesh filters to a main supply header fitted in the bed plate casing. High pressure oil shall be supplied to the main and big end bearings, cam-shaft bearings, cam-shaft chain and gear drives, governor, auxiliary drive gears etc. Valve gear shall be lubricated at reduced pressure through a reducing valve and the cams by an oil bath.

6.01.22 **Cooling Water System**

Direct cooling or heat exchanger type cooling system shall be employed for the diesel engine. Water shall be tapped from the fire pump discharge. This water shall be led through duplex strainer, pressure breakdown orifice and then after passing through the engine, the water at the outlet shall be taken directly to the sump through an elevated funnel.

6.02.00 **Testing & Inspection**

- 6.02.01 The manufacturer shall conduct all tests required, to ensure that the equipment furnished conforms to the requirement of this sub-section

and in compliance with requirements of applicable codes. The particulars of the proposed tests and the procedure for the tests shall be submitted to the Employer for approval before conducting the tests.

- 6.02.02 At manufacturer's works, tests shall be carried out during and after completion of manufacture of different component/parts and the assembly as applicable. Following tests shall be conducted.
- 6.02.03 Material analysis and testing.
- 6.02.04 Hydrostatic pressure testing of all pressure parts.
- 6.02.05 Static and dynamic balance tests of rotating parts at applicable over-speed and determination of vibration level.
- 6.02.06 MPI/DPT on machined parts of piston and cylinder.
- 6.02.07 Ultrasonic testing of crankshaft and connecting rod after heat treatment.
- 6.02.08 Dimensional check of close tolerance components like piston, cylinder bore etc.
- 6.02.09 Calibration tests of all fuel pumps, injectors, standard orifices, nozzles, instruments etc.
- 6.02.10 Over speed test of the assembly at 120% of rated speed.
- 6.02.11 Power run test.
- 6.02.12 Performance test of the diesel engine to determine its torque, power and specific fuel consumption as function of shaft speed. Performance test of the engine shall be carried for 12 hours out of which 1 hour at full load and one hour at 110% overload.
- 6.02.13 Measurement of vibration & noise.

(i) Measurement of vibration

The vibration shall be measured during full load test as well as during the overload test and limit shall be 100 microns.

(ii) Measurement of noise level

The equivalent 'A' weighted sound level measured at a distance of 1.5 M above floor level in elevation and 1.0 M horizontally from the base of the equipment, expressed in dB to a reference of 0.0002 microbar shall not exceed 93 dBA.

Above tests for vibration shall be repeated at site as pre-commissioning

tests.

6.02.14 Adjustment of speed governor as per BS:5514.

6.02.15 Diesel engine shall be subjected to routine tests as per IS:10000/BS:5514.

## 7.00.00 **PIPING, VALVES AND SPECIALITIES**

This clause covers the design, manufacture, shop testing, erection, testing and commissioning of piping, valves and specialities.

### 7.02.00 **Scope**

The piping system which shall include but not be limited to the following:

7.02.01 Plain run of piping, bends, elbows, tees, branches, laterals, crosses, reducing unions, couplings, caps, expansion joints, flanges, blank flanges, thrust blocks, anchors, hangers, supports, saddles, shoes, vibration dampeners, sampling connections, hume pipes etc.

7.02.02 Gaskets, ring joints, backing rings, jointing material etc. as required. Also all welding electrodes and welding consumables including special ones, if any.

7.02.03 Instrument tapping connections, stubs etc.

7.02.04 Gate and globe valves to start/stop and regulate flow and swing check valves for one directional flow.

7.02.05 Basket strainers and Y-type strainers

7.02.06 Bolts, nuts, fasteners as required for interconnecting piping, valves and fittings as well as for terminal points. For pipe connections into Owner's R.C.C. works, Bidder will furnish all inserts.

7.02.07 Painting, anti-corrosive coatings etc. of pipes and equipment.

Adequate number of air release valves shall be provided at the highest points in the piping system to vent any trapped air in the system.

### 7.03.00 **Design**

7.03.01 Material of construction of various pipes shall be as follows :

#### (a) **Buried Pipes**

Mild steel black pipes as per IS:1239, Part-I medium grade (for pipes of sizes 150 NB and below) or IS:3589, Fe 410 grade (for pipes of sizes 200 NB and above) suitably lagged on the outside to

prevent soil corrosion, as specified elsewhere.

(b) **Overground Pipes normally full of water**

Mild steel black pipes as per IS:1239, Part-I medium grade (for pipes for sizes 150 NB and below) or IS:3589, Fe 410 grade (for pipes of sizes 200 NB and above).

(c) Overground pipes normally empty, but periodic charge of water and for detector line for HVW System.

Mild steel galvanised pipes as per IS:1239, Part-I medium grade (for pipes of sizes 150 NB and below) or IS:3589, Fe 410 grade (for pipes of sizes 200 NB and above).

- 7.03.02 All fittings to be used in connection with steel pipe lines upto a size of 80 mm shall be as per IS:1239. Part-II Mild steel tubulars and other wrought steel pipe fittings, Heavy grade. Fittings with sizes above 80 mm upto 150 mm shall be fabricated from IS:1239 Heavy grade pipes or steel plates having thickness not less than those of IS:1239 Part-I Heavy grade pipes. Fittings with sizes above 150 mm shall be fabricated from IS:3589 Class-2 pipes. All fitting used in GI piping shall be threaded type. Welding shall not be permitted on GI piping.
- 7.03.03 Pipe sizes shall not be less than the sizes indicated in the attached drawings.
- 7.03.04 For steel pipeline, welded construction should be adopted unless specified otherwise.
- 7.03.06 All piping system shall be capable of withstanding the maximum pressure arising from any condition of operation and testing including water hammer effects.
- 7.03.09 Gate/sluice valve shall be used for isolation of flow in pipe lines and **construction** shall be as per IS:778 (for size up to 40 mm) and IS:14846 (for sizes above 40 mm) except **for valve spindle movement**. Valves shall be of rising spindle type and of PN 1.6 class
- 7.03.10 Gate Valves shall be provided with the following :
- (a) Hand wheel.
  - (b) Position indicator.
  - (c) Locking facility (where necessary).
- 7.03.11 Gate valves shall be provided with back seating bush to facilitate gland removal during full open condition.

- 7.03.12 Globe valves shall be provided with contoured plug to facilitate regulation and control of flow. All other requirements should generally follow those of gate valve.
- 7.03.13 Non-return valves shall be swing check type. Valves will have a permanent "arrow" inscription on its body to indicate direction of flow of the fluid. These valves shall generally conform to IS:5312.
- 7.03.14 Whenever any valve is found to be so located that it cannot be approached manually from the nearest floor/gallery/platform hand wheel with floor stand or chain operator shall be provided for the same.
- 7.03.15 Valves below 50 mm size shall have screwed ends while those of 50 mm and higher sizes shall have flanged connections.

7.03.14 **Basket Strainer**

- a) Basket strainers shall be of 30mesh and have the following materials of construction :

Body: Fabricated mild steel as per IS:2062 (Tested Quality).  
Strainer Wires: stainless steel (AISI : 316), 30 SWG, suitably reinforced.

- b) Inside of basket body shall be protected by two (2) coats of heavy duty bitumastic paint.
- c) Strainers shall be Simplex design. Suitable vent and drain connections with valves shall be provided.
- d) Screen open area shall be at least 4 times pipe cross sectional area at inlet.
- e) Pressure drop across strainer in clean condition shall not exceed **1.5 MWC at 410M3/hr (for 765kV/400kV substations) and 1 MWC at 273M3/hr flow (for 220kV & 132kV substations)**. Pressure drop test report of strainer of same design shall be furnished.

7.03.15 **Y-type On-line Strainer**

Body shall be constructed of mild steel as per IS:2062 (tested quality). Strainer wires shall be of stainless steel AISI:316, 30 SWG, 30 mesh.

Blowing arrangement shall be provided with removable plug at the outlet. Screen open area shall be atleast 4 times pipe cross-sectional area at inlet.

Pressure drop test report of strainer of same design shall be furnished.

7.03.16 **Hydrant Valve (Outdoor) and Indoor Hydrant Valves (Internal**

### Landing Valves).

The general arrangement of outdoor stand post assembly, consisting of a column pipe and a hydrant valve with a quick coupling end shall be as per TAC requirement.

Materials of construction shall be as follows :

- |                              |   |
|------------------------------|---|
| a) Column pipe               | M.S. IS:1239 med. grade.                          |
| b) Hydrant Valve             |   |
| i) Body                      | <b>Stainless steel.</b>                           |
| ii) Trim                     | Leaded tin bronze as per IS:318, Grade-LTB 2.     |
| iii) Hand Wheel              | Cast Iron as per IS:210, Grade FG:200.            |
| iv) Washer, gasket, etc.     | Rubber as per IS:638.                             |
| v) Quick coupling connection | Leaded tin bronze as per IS:318, Grade-LTB 2.     |
| vi) Spring                   | Phosphor Bronze as per IS:7608.                   |
| vii) Cap and chain           | Leaded tin bronze as per IS:318, Grade-LTB etc.2. |

The general design of hydrant valve shall conform to IS:5290.

#### 7.03.17 Hoses, Nozzles, Branch pipes and Hose boxes

- (a) Hose pipes shall be of reinforced rubber-lined canvas construction as per type A of IS:636 with nominal size of 63 MM (2 1/2") and lengths of 15 metre or 7.5 metre, as indicated elsewhere. All hoses shall be ISI marked.
- (b) Hosepipes shall be capable of withstanding an internal water pressure of not less than 35.7 kg/cm<sup>2</sup> without bursting. It must also withstand a working pressure of 8.5 kg/cm<sup>2</sup> without undue leakage or sweating.
- (c) Each hose shall be fitted with instantaneous spring lock type couplings at both ends. Hose shall be fixed to the coupling ends by copper rivets and the joint shall be reinforced by 1.5 mm galvanised mild steel wires and leather bands.

- (d) Branch pipes shall be constructed of copper and have rings of leaded tin bronze (as per IS:318 Grade-2) at both ends. One end of the branch pipe will receive the quick coupling while the nozzles will be fixed to the other end.
- (e) Nozzles shall be constructed of leaded tin bronze as per IS:318, Grade-2.
- (f) Suitable spanners of approved design shall be provided in adequate numbers for easy assembly and dismantling of various components like branch pipes, nozzles, quick coupling ends etc.
- (g) Hose pipes fitted with quick coupling ends, branch pipes, nozzles spanner etc. will be kept in a hose box, which will be located near point of use. The furnished design must meet the approval of Tariff Advisory Committee.
- (h) All instantaneous couplings, as mentioned under clause Nos.3.03.19, 3.03.20 and 3.03.21 above shall be of identical design (both male and female) so that any one can be interchanged with another. One male, female combination shall get locked in by mere pushing of the two halves together but will provide leak tightness at a pressure of 8 kg/cm<sup>2</sup> of water. Designs employing screwing or turning to have engagement shall not be accepted.

#### 7.04.00 **Fabrication & Erection**

7.04.01 The contractor shall fabricate all the pipe work strictly in accordance with the related approved drawings.

#### 7.04.02 **End Preparation**

- (a) For steel pipes, end preparation for butt welding shall be done by machining.
- (b) Socket weld end preparation shall be sawing/machining.
- (c) For tees, laterals, mitre bends, and other irregular details cutting templates shall be used for accurate cut.

#### 7.04.03 **Pipe Joints**

- (a) In general, pipes having sizes over 25 mm shall be joined by butt welding. Pipes having 25 mm size or less shall be joined by socket welding/screwed connections. Galvanised pipes of all sizes shall have screwed joints. No welding shall be permitted on GI pipes. Screwed joints shall have tapered threads and shall be assured of leak tightness without using any sealing compound.
- (b) Flanged joints shall be used for connections to vessels, equipment,

flanged valves and also on suitable straight lengths of pipe line of strategic points to facilitate erection and subsequent maintenance work.

#### 7.04.04 **Overground Piping**

- (a) Piping to be laid overground shall be supported on pipe rack/supports. Rack/supports details shall have to be approved by Employer/Engineer.
- (b) Surface of overground pipes shall be thoroughly cleaned of mill scale, rust etc. by wire brushing. Thereafter one (1) coat of **red oxide primer** shall be applied. Finally two (2) coats of synthetic enamel paint of approved colour shall be applied.

#### 7.04.05 **Buried Pipe Lines**

- (a) Pipes to be buried underground shall be provided with protection against soil corrosion by coating and wrapping with two coats of coal tar hot enamel paint and two wraps of reinforced fibre glass tissue. The total thickness of coating and wrapping shall not be less than 3 mm. Alternatively corrosion resistant tapes can also be used for protection of pipes against corrosion.
- (b) Coating and wrapping and holiday testing shall be in line with IS:10221.
- (c) Buried pipelines shall be laid with the top of pipe one meter below ground level.
- (d) At site, during erection, all coated and wrapped pipes shall be tested with an approved Holiday detector equipment with a positive signalling device to indicate any fault hole breaks or conductive particle in the protective coating.

#### 7.05.00 **General Instruction for Piping Design and Construction**

7.05.01 While erecting field run pipes, the contractor shall check, the accessibility of valves, instrument tapping points, and maintain minimum headroom requirement and other necessary clearance from the adjoining work areas.

7.05.02 Modification of prefabricated pipes, if any, shall have to be carried out by the contractor at no extra charge to the Employer.

#### 7.05.03 **Welding**

- (i) Welding shall be done by qualified welders only.

- (ii) Before welding, the ends shall be cleaned by wire brushing, filing or machine grinding. Each weld-run shall be cleaned of slag before the next run is deposited.
- (iii) Welding at any joint shall be completed uninterrupted. If this cannot be followed for some reason, the weld shall be insulated for slow and uniform cooling.
- (iv) Welding shall be done by manual oxyacetylene or manual shielded metal arc process. Automatic or semi-automatic welding processes may be done only with the specific approval of Employer/ Consultant.
- (v) As far as possible welding shall be carried out in flat position. If not possible, welding shall be done in a position as close to flat position as possible.
- (vi) No backing ring shall be used for circumferential butt welds.
- (vii) Welding carried out in ambient temperature of 5°C or below shall be heat-treated.
- (viii) Tack welding for the alignment of pipe joints shall be done only by qualified welders. Since tack welds form part of final welding, they shall be executed carefully and shall be free from defects. Defective welds shall be removed prior to the welding of joints.

Electrodes size for tack welding shall be selected depending upon the root opening.

- (ix) Tacks should be equally spaced as follows :
  - for 65 NB and smaller pipes : 2 tacks
  - for 80 NB to 300 NB pipes : 4 tacks
  - for 350 NB and larger pipes : 6 tacks
- (x) Root run shall be made with respective electrodes/filler wires. The size of the electrodes/filler wires. The size of the electrodes shall not be greater than 3.25 mm (10 SWG) and should preferably be 2.3 mm (12 SWG). Welding shall be done with direct current values recommended by the electrode manufacturers.
- (xi) Upward technique shall be adopted for welding pipes in horizontally fixed position. For pipes with wall thickness less than 3 mm, oxyacetylene welding is recommended.

- (xii) The root run of butt joints shall be such as to achieve full penetration with the complete fusion of root edges. The weld projection shall not exceed 3 mm inside the pipe.
- (xiii) On completion of each run craters, weld irregularities, slag etc. shall be removed by grinding or chipping.
- (xiv) Fillet welds shall be made by shielded metal arc process regardless of thickness and class of piping. Electrode size shall not exceed 10 SWG. (3.25 mm). At least two runs shall be made on socket weld joints.

#### 7.06.00 **Tests at Works**

##### 7.06.01 **Pipes**

- (i) Mechanical and chemical tests shall be performed as required in the codes/standards.
- (ii) All pipes shall be subjected to hydrostatic tests as required in the codes/standards.
- (iii) 10% spot Radiography test on welds of buried pipes shall be carried out as per ASME VIII.

##### 7.06.02 **Valves**

- (i) Mechanical and chemical tests shall be conducted on materials of the valve as required in the codes/standards.
- (ii) All valves shall be tested hydrostatically for the seat as well as required in the code/standards for a period of ten minutes.
- (iii) Air test shall be conducted to detect seat leakage.
- (iv) Visual check on the valve and simple operational test in which the valve will be operated thrice from full open to full close condition.
- (v) No repair work on CI valve body, bonnet or wedge shall be allowed.

##### 7.06.03 **Strainers**

- (i) Mechanical and chemical tests shall be conducted on materials of the strainer.
- (ii) Strainers shall be subjected to a hydrostatic test pressure of 1.5 times the design pressure or 10 kg/cm<sup>2</sup> whichever is higher for a period of one hour.

#### 7.06.04 **Hydrant valves and Indoor Hydrant Valves (Internal Landing Valves)**

- (i) The stand post assembly along with the hydrant valve (valve being open and outlet closed) shall be pressure tested at a hydrostatic pressure of 21 kg/cm<sup>2</sup>g to detect any leakage through defects of casting.
- (ii) Flow test shall be conducted on the hydrant valves at a pressure of 7 kg/cm<sup>2</sup>g and the flow through the valve shall not be less than 900 litres/min.
- (iii) Leak tightness test of the valve seat shall be conducted at a hydrostatic test pressure of 14 kg/cm<sup>2</sup>g.

#### 7.06.05 **Hoses, Nozzles, Branch Pipes and Hose Boxes**

Reinforced rubber-lined canvas hoses shall be tested hydrostatically. Following tests shall be included as per IS:636.

- a) Hydrostatic proof pressure test at 21.4 kgf/cm<sup>2</sup>g
- b) Internal diameter

The branch pipe, coupling and nozzles shall be subjected to a hydrostatic test pressure of 21 kg/cm<sup>2</sup>g for a period of 2<sup>1</sup>/<sub>2</sub> minutes and shall not show any sign of leakage or sweating.

Dimensional checks shall be made on the hose boxes and nozzle spanners.

#### 8.00.00 **AIR VESSELS**

8.01.00 Air vessels shall be designed and fabricated of mild steel as class-II vessels as per IS:2825 for a pressure of 14kg/cm<sup>2</sup> and shall be minimum 3 m<sup>3</sup> capacity.

8.02.00 Inside surface of the tank shall be protected by anti-corrosive paints/coatings/linings as required.

8.03.00 Outside surfaces of the vessels shall be provided with one (1) coat of red lead primer with two (2) coats of synthetic enamel paint of approved colour and characteristics.

#### 8.04.00 **Tests & Inspection**

8.04.01 Air vessels shall be hydraulically tested at 21kg/cm<sup>2</sup> for a period not less than one (1) hour.

8.04.02 All materials used for fabrication shall be of tested quality and test

certificates shall be made available to the Owner.

8.04.03 Welding procedure and Welder's qualification tests will be carried out as per relevant IS Standard.

8.04.04 NDE tests, which will include 100% Radiography on longitudinal seams and spot Radiography for circumferential seams, for pressure vessel will be carried out.

## 9.00.00 HEAT DETECTORS/FIRE DETECTORS AND SPRAY NOZZLES

### 9.00.01 Intent of Specification

This specification lays down the requirements of the smoke detectors, heat detectors and spray nozzles for use in various sub-systems of the fire protection system.

### 9.00.02 Codes and Standards

All equipment supplied shall conform to internationally accepted codes and standards. All equipment offered by Bidders should be TAC approved or have been in use in installations which have been approved by TAC.

### 9.01.00 Heat Detectors, Quartzoid bulb type. (Used in HVW spray system)

- a) Heat detectors shall be of any approved and tested type. Fusible chemical pellet type heat detectors are however not acceptable.
- b) Temperature rating of the heat detector shall be selected by the Bidder taking into consideration the environment in which the detectors shall operate. Minimum set point shall, however, be 79°C.
- c) Heat detectors shall be guaranteed to function properly without any maintenance work for a period of not less than twenty five (25) years.
- d) The heat detectors shall be mounted on a pipe network charged with water at suitable pressure. On receipt of heat from fire, the heat detector will release the water pressure from the network. This drop in water pressure will actuate the Deluge valve.

### 9.02.00 HVW Spray Nozzles (Projectors)

High velocity water spray system shall be designed and installed to discharge water in the form of a conical spray consisting of droplets of water travelling at high velocity which shall strike the burning surface with sufficient impact to ensure the formation of an emulsion. At the same time the spray shall efficiently cut off oxygen supply and provide

sufficient cooling. Integral non-ferrous strainers shall be provided in the projectors ahead of the orifice to arrest higher size particle, which are not allowed to pass through the projectors.

**9.03.00 Fire Detectors (Used in fire detection and alarm system)**

- 9.03.01 Fire detectors shall be approved by FOC-London or similar international authorities.
- 9.03.02 Both smoke and heat type fire detectors shall be used. Bidder shall clearly indicate the mode of operation of detectors in his proposal.
- 9.03.03 The set point shall be selected after giving due consideration for ventilating air velocity and cable insulation.
- 9.03.04 Fire detectors shall be equipped with an integral L.E.D. so that it shall be possible to know which of the detectors has been operated. The detectors, which are to be placed in the space above the false ceiling or in the floor void shall not have the response indicators on the body but shall be provided with remote response indicators.
- 9.03.05 Approval from Department of Atomic Energy (DAE), Government of India shall be made available for ionisation type smoke detectors. All accessories required to satisfy DAE shall also be included in the scope of supply.
- 9.03.06 Fire detectors shall be guaranteed to function properly without any maintenance work for a period of not less than ten (10) years.

**10.00.00 PORTABLE AND WHEEL/ TROLLEY MOUNTED FIRE EXTINGUISHERS**

- 10.00.01 This specification lays down the requirement regarding fire extinguishers of following types :

Portable fire extinguishers.

- a) Pressurised water type.
- b) Dry chemical powder type
- c) Carbon Dioxide type

Wheel/ Trolley mounted fire extinguishers.

- a) Mechanical foam type

- 10.00.02 All the extinguishers offered by the Bidder shall be of reputed make and shall be ISI marked.

### 10.01.00 **Design and Construction**

- 10.01.01 All the portable extinguishers shall be of freestanding type and shall be capable of discharging freely and completely in upright position.
- 10.01.02 Each extinguisher shall have the instructions for operating the extinguishers on its body itself.
- 10.01.03 All extinguishers shall be supplied with initial charge and accessories as required.
- 10.01.04 Portable type extinguishers shall be provided with suitable clamps for mounting on walls or columns.
- 10.01.05 All extinguishers shall be painted with durable enamel paint of fire red colour conforming to relevant Indian Standards.
- 10.01.06 Pressurisation of water type fire extinguishers shall either be done by compressed air or by using gas cartridge. **Both constant air pressure and the gas pressure type shall conform to IS 15683:2006.** Both these extinguishers shall be ISI marked.
- 10.01.07 **Dry chemical powder type portable extinguisher shall conform to IS 15683:2006.**
- 10.01.08 **Carbon Dioxide type portable extinguisher shall conform to IS:15683:2006 and Carbon Dioxide type trolley mounted extinguisher shall conform to IS:2878.**
- 10.01.09 Wheel/ trolley mounted fire extinguishers of 50 litre capacity Mechanical foam type shall conform to IS:13386

### 10.02.00 **Tests and Inspection**

- 10.02.01 A performance demonstration test at site of five (5) percent or one (1) number whichever is higher, of the extinguishers shall be carried out by the Contractor. All consumable and replaceable items require for this test would be supplied by the Contractor without any extra cost to Employer.
- 10.02.02 Performance testing of extinguisher shall be in line of applicable Indian Standards. In case where no Indian Standard is applicable for a particular type of extinguisher, the method of testing shall be mutually discussed and agreed to before placement of order for the extinguishers.

### 10.03.00 **Painting**

Each fire extinguisher shall be painted with durable enamel paint of fire red colour conforming to relevant Indian Standards.

## 11.00.00 INSTRUMENTS

### 11.00.01 Intent of Specification

The requirements given in the sub-section shall be applicable to all the instruments being furnished under this specification.

11.00.02 All field mounted instruments shall be weather and dust tight, suitable for use under ambient conditions prevalent in the subject plant. All field mounted instruments shall be mounted in suitable locations where maximum accessibility for maintenance can be achieved.

### 11.01.00 Local Instruments

Pressure/ Differential Gauges & Switches.

11.01.01 The pressure sensing elements shall be continuous 'C' bourdon type.

11.01.02 The sensing elements for all gauges/switches shall be properly aged and factory tested to remove all residual stresses. They shall be able to withstand atleast twice the full scale pressure/vacuum without any damage or permanent deformation.

11.01.03 For all instruments, connection between the pressure sensing element and socket shall be braced or hard soldered.

11.01.04 Gauges shall be of 150 mm diameter dial with die-cast aluminium, stoved enamel black finish case, aluminium screwed ring and clear plastic crystal cover glass. Upper range pointer limit stop for all gauges shall be provided.

11.01.05 All gauges shall be with stainless steel bourdon having rotary geared stainless steel movements.

11.01.06 Weatherproof type construction shall be provided for all gauges. This type of construction shall be fully dust tight, drip tight, weather resistant and splash proof with anti-corrosive painting conforming to NEMA- 4.

11.01.07 All gauges shall have micrometer type zero adjuster.

11.01.08 Neoprene safety diaphragm shall be provided on the back of the instruments casing for pressure gauges of ranges 0-10 Kg/cm<sup>2</sup> and above.

11.01.09 Scales shall be concentric, white with black lettering and shall be in metric units.

11.01.10 Accuracy shall be  $\pm 1.0$  percent of full range or better.

- 11.01.11 Scale range shall be selected so that normal process pressure is approximately 75 percent of full scale reading. For pressure gauges and pressure switches, the range shall not be less than 0 -16 Kg/cm<sup>2</sup>
- 11.01.12 All gauges shall have 1/2 inch NPT bottom connection.
- 11.01.13 All instruments shall conform to IS: 3624 - 1966.
- 11.01.14 All instruments shall be provided with 3 way gauge isolation valve or cock. Union nut, nipple and tail pipe shall be provided wherever required.
- 11.01.15 Switch element contact shall have two (2) NO and two (2) NC contacts rated for 240 Volts, 10 Amperes A.C. or 220 Volts, 5 Amperes D.C. Actuation set point shall be adjustable throughout the range. ON-OFF differential (difference between switch actuation and de-actuation pressures) shall be adjustable. Adjustable range shall be suitable for switch application.
- 11.01.16 Switches shall be sealed diaphragm, piston actuated type with snap action switch element. Diaphragm shall be of 316 SS.
- 11.01.18 Necessary accessories shall be furnished.

#### 11.02.00 **Timers**

- 11.02.01 The timers shall be electro-mechanical type with adjustable delay on pick-up or reset as required.
- 11.02.02 Each timer shall have two pairs of contacts in required combination of NO and NC.

#### 11.03.00 **Level Gauges/Indicator/Switches**

##### 11.03.01 **Level Gauges**

- i) Gauge glasses shall be used for local level indication wherever shown in the flow diagram.
- ii) Gauge glasses, in general, shall be flag glass type with bolted cover. Body and cover material shall be of carbon steel with rubber lining.
- iii) Level coverage shall be in accordance with operating requirements. Maximum length of a single gauge glass shall not exceed 1.4 M. Should a larger gauge glass be required, multiple gauges of preferably equal length shall be used with 50 mm overlap in visibility.
- iv) Reflex type gauge glasses shall be used for colourless liquids and

transparent type gauge glasses shall be used for all liquids having colour.

- v) Each gauge glass shall be complete with a pair of offset valves. Valves shall have union bonnet, female union level connection, flanged tank connection, and vent and drain plug.
- vi) Offset valves shall have corrosion resistant ball-check to prevent fluid loss in the event of gauge glass breakage. Valve body shall have a working pressure of 200 percent of the maximum static pressure at the maximum process fluid temperature. Valve body materials shall be of carbon steel with rubber lining.

#### 11.03.02 Level Indicators

- i) Float type mechanical level gauges with linear scale type indicator shall be offered for measuring level of tanks wherever shown in the flow diagram.
- ii) AISI-316 stainless steel float, guide rope and tape shall be used. Housing shall be of mild steel painted with anti-corrosive painting.
- iii) The scale indicator shall be provided at a suitable height for ease of reading.
- iv) Accuracy shall be + 1% of scale range or better.

#### 11.03.03 Level Switches

- i) Level switches shall be of ball float operated magnetic type complete with cage.
- ii) Materials of construction shall be suitable for process and ambient conditions. The float material shall be AISI-316 stainless steel.
- iii) Actuating switches shall be either hermetically sealed mercury type or snap acting micro-switches. Actuation set point shall be adjustable. ON-OFF differential (difference between switch actuation and de-actuation levels) shall be adjustable. Adjustable range shall be suitable for switch application. All switches shall be repeatable within + 1.0 percent of liquid level change required to activate switch. Contacts shall be rated for 50 watts resistive at 240 V A.C. Number of contacts shall be two NO and two NC for each level switch.

#### 11.04.00 Solenoid Valves

11.04.01 The body of the valves shall be Forged brass or stainless steel.

11.04.02 The coil shall be continuous duty, epoxy moulded type Class-F, suitable for high temperature operation.

11.04.03 The enclosure shall be watertight, dust-tight and shall conform to NEMA-4 Standard.

11.04.04 The valves shall be suitable for mounting in any position.

**11.05.00 Switches, Lamps, Meters Etc.**

All electrical components on the panel namely push buttons, switches, lamps, meters etc. shall meet the requirements of sub-section Electrical enclosed with the specification.

11.06.00 All local instruments shall be inspected by Employer/Consultant as per the agreed quality plan.

11.07.00 Makes of control panel and local instruments, accessories shall be as per Employer's approval.

**12.00.00 ELECTRIC MOTORS**

**12.01.00 General**

12.01.01 This clause covers the requirements of three phase squirrel cage induction motors and single-phase induction motors.

12.01.02 The motors to be furnished, erected and commissioned as covered under this specification shall be engineered, designed, manufactured, erected, tested as per the requirements specified herein. These requirements shall however be read along with the requirements of the respective driven equipment being supplied under the specification of which this specification forms a part.

12.01.03 The motor supplied under this specification shall conform to the standards specified in GTR.

12.01.04 Terminal point for all motors supplied under this specification shall be at the respective terminal boxes.

12.01.05 Materials and components not specifically stated in this specification but are necessary for satisfactory operation of the motor shall be deemed to be included in the scope of supply of this specification.

12.01.06 Notwithstanding anything stated in this motor specification, the motor has to satisfy the requirement of the mechanical system during normal and abnormal conditions. For this the motor manufacturer has to co-ordinate with the mechanical equipment supplier and shall ensure that the motor being offered meets the requirements.

**12.02.00 Codes & Standards**

- 12.02.21 The design, manufacture, installation and performance of motors shall conform to the provisions of latest Indian Electricity Act and Indian Electricity Rules. Nothing in these specifications shall be construed to relieve the Contractor of his responsibility.
- 12.02.22 In case of contradiction between this specifications and IS or IEC, the stipulations of this specification shall be treated as applicable.
- 12.02.23 National Electrical code for hazardous location and relevant NEMA standard shall also be applicable for motors located in hazardous location.

### 12.03.00 **Design Features**

#### 12.03.01 **Rating and type**

- (i) The induction motors shall be of squirrel cage type unless specified otherwise.
- (ii) The motors shall be suitable for continuous duty in the specified ambient temperature.
- (iii) The MCR KW rating of the motors for 50°C ambient shall not be less than the power requirement imposed at the motor shaft by the driven equipment under the most onerous operation conditions as defined elsewhere, when the supply frequency is 51.5 Hz (and the motor is running at 103% of its rated speed).
- (iv) Motors shall be capable of giving rated output without reduction in the expected life span when operated continuously in the system having the following particulars :
  - a) Rated terminal voltage
 

From 0.2 to 200 KW	415V (3 Phase, solidly earthed)
Below 0.2 KW	240 V (1 Phase, solidly earthed)

Variation in voltage  $\pm$  6%.
  - b) Frequency     50 Hz  $\pm$  3%.
  - c) Any combination of (a) & (b)

#### 12.03.02 Enclosure

Motors to be installed outdoor and semi-outdoor shall have hose proof enclosure equivalent to IP-55 as per IS: 4691. For motors to be installed indoor, the enclosure shall be dust proof equivalent to IP-54 as

per IS: 4691.

#### 12.03.03 **Cooling method**

Motors shall be TEFC (totally enclosed fan cooled) type.

#### 12.03.04 **Starting requirements**

##### (i) **Induction motor**

- a) All induction motors shall be suitable for full voltage direct on-line starting. These shall be capable of starting and accelerating to the rated speed alongwith the driven equipment without exceeding the acceptable winding temperature even when the supply voltage drops down to 80% of the rated voltage.
- b) Motors shall be capable of withstanding the electro-dynamic stresses and heating imposed if it is started at a voltage of 110% of the rated value.
- c) The starting current of the motor at rated voltage shall not exceed six (6) times the rated full load current subject to tolerance as given in IS : 325.
- d) Motors when started with the driven equipment imposing full starting torque under the supply voltage condition specified under Clause 12.03.01 (iv) (a) shall be capable of withstanding at least two successive starts with coasting to rest between starts and motor initially at the rated load operating temperature. The motors shall also be suitable for three equally spread starts per hour, the motor initially at a temperature not exceeding the rated operating temperature.
- e) The locked rotor withstand time under hot condition at 110% of rated voltage shall be more than the starting time with the driven equipment at minimum permissible voltage (clause 12.03.04 (i) (a) by at least two seconds or 15% of the accelerating time whichever is greater. In case it is not possible to meet the above requirement the Bidder shall offer centrifugal type speed switch mounted on the motor shaft which shall remain closed for speeds lower than 20% and open for speeds above 20% of the rated speed. The speed switch shall be capable of withstanding 120% of the rated speed in either direction of rotation.

#### 12.03.05 **Running requirements**

- (i) When the motors are operating at extreme condition of voltage and frequency given under clause no.12.03.01 (iv) the maximum permissible temperature rise over the ambient temperature of 50oC shall be within the limits specified in IS : 325 after adjustment due

to increase ambient temperature specified herein.

- (ii) The double amplitude of motor vibration shall be within the limits specified in IS: 4729. Vibration shall also be within the limits specified by the relevant standard for the driven equipment when measured at the motor bearings.
- (iii) All the induction motors shall be capable of running at 80% of rated voltage for a period of 5 minutes with rated load commencing from hot condition.
- (iv) Induction motors shall be so designed as to be capable of withstanding the voltage and torque stresses developed due to the difference between the motor residual voltage and incoming supply voltage during fast changeover of buses. The necessary feature incorporated in the design to comply with this requirement shall be clearly indicated in the proposal.
- (v) Motors shall be capable of developing the rated full load torque even when the supply voltage drops to 70% of rated voltage. Such operation is envisaged for a period of one second. The pull out torque of the induction motors to meet this requirement shall not be less than 205% of full load torque.
- (vi) The motors shall be capable of withstanding for 10 seconds without stalling or abrupt change in speed (under gradual increase of torque) an excess torque of 60 percent of their rated torque, the voltage and frequency being maintained at their rated value.
- (vii) Guaranteed performance of the motors shall be met with tolerances specified in respective standards.

#### 12.04.00 **Construction Features**

##### 12.04.01 **Stator**

###### (i) **Stator frame**

The stator frames and all external parts of the motors shall be rigid fabricated steel or of casting. They shall be suitably annealed to eliminate any residual stresses introduced during the process of fabrication and machining.

###### (ii) **Stator core**

The stator laminations shall be made from suitable grade magnetic sheet steel varnished on both sides. They shall be pressed and clamped adequately to reduce the core and teeth vibration to minimum.

###### (iii) **Insulation and winding**

All insulated winding conductor shall be of copper. The overall motor winding insulation for all 415 volts motors shall be of epoxy thermosetting type i.e., class 'F' but limited to class-B operating from temperature rise consideration. Other motors may be of conventional class-B type. The windings shall be suitable for successful operation in hot, humid, tropical climate with the ambient temperature of 50°C.

#### 12.04.02 **Rotor**

- (i) Rotors shall be so designed as to keep the combined critical speed with the driven equipment away from the running speed by atleast 20%.
- (ii) Rotors shall also be designed to withstand 120% of the rated speed for 2 minutes in either direction of rotation.

#### 12.04.03 **Terminal box leads**

- (i) For motors of 415 Volts and below a single terminal box may be provided for power and accessories leads.
- (ii) Terminal boxes shall be of weatherproof construction designed for outdoor service. To eliminate entry of dust and water, gaskets of neoprene or approved equivalent shall be provided at cover joints and between box and motor frame.
- (iii) Terminal box shall be suitable for top and bottom entry of cables.
- (iv) Unless otherwise approved, the terminal box shall be capable of being turned through 360° in steps in 90°.
- (v) The terminals shall be complete with all accessories for connecting external cables. They shall be designed for the current carrying capacity and shall ensure ample phase to phase to ground clearances.
- (vi) Suitable tinned brass compression type cable glands and cable lugs shall be supplied by the Contractor to match Employer's cable.
- (vii) Terminal box for single core cable shall be of non- magnetic material.
- (viii) Marking of all terminals shall be in accordance with IS : 4728.

#### 12.04.04 **Rating Plates**

- (i) Rating plates shall be provided for all motors giving the details as called for in IS:325 (for three phase squirrel cage induction

motors).

- (ii) In addition to above, the rating plate shall indicate the following :
  - a) Temperature rise in oC under normal working conditions.
  - b) Phase sequence corresponding to the direction of rotation for the application.
  - c) Bearing identification number (in case of ball/ roller bearing) and recommended lubricants.

#### 12.04.05 **Other Constructional Features**

- (i) Two independent earthing points shall be provided on opposite sides of the motor for bolted connection of Employer's earthing conductor to be specified to the successful Bidder.
- (ii) Motor weighing more than 25 kg. shall be provided with eyebolts, lugs or other means to facilitate lifting.

#### 12.05.00 **Paint and Finish**

12.05.01 Motor external parts shall be finished and painted to produce a neat and durable surface, which would prevent rusting and corrosion. The equipment shall be thoroughly degreased, all sharp edges and scales removed and treated with one coat of primer and two coats of grey enamel paint.

12.05.02 Motor fans shall also be painted to withstand corrosion.

12.05.03 All fasteners used in the construction of the equipment shall be either of corrosion resistant material or heavy cadmium plated.

12.05.04 Current carrying fasteners shall be either of stainless steel or high tensile brass.

#### 12.06.00 **Tests at Manufacturers Works**

12.06.01 Motors shall be subject to routine tests in accordance with IS : 325 & IS : 4029 standards.

12.06.02 In addition, the following tests shall also be carried out :

- a) 20% over speed test for 2 minutes on all rotors.
- b) Measurement of vibration.
- c) Measurement of noise level.

- d) Phase sequence and polarity checks relative to mechanical rotation.

#### 12.06.03 Tests after installation at site

- (i) After installation and commissioning at site, the motors alongwith the driven equipment shall be subject to tests to ascertain their conformity with the requirement of this specification and those of the driven equipment specification and the performance data quoted by the Bidder.
- (ii) In case of non-conformity of the motor with these specifications and performance requirement, the Engineer may at his discretion reject or ask for necessary rectification/replacement as detailed in general Terms and Conditions of Contract (GCC) Volume-I.

#### 13.00.00 BATTERY & BATTERY CHARGERS

This clause covers the design, performance, manufacturing, construction features and testing of Battery and Battery charger used primarily for starting the diesel engine driving the fire water pumps. Battery Chargers shall be housed in Diesel Engine Panel.

##### 13.01.00 General Information

- 13.01.01 The equipment specified hereinafter are required for starting the diesel engines and other operation of the plant as required.
- 13.01.02 For each diesel engine there shall be two (2) sets of Battery and two (2) sets of Battery Charger.
- 13.01.03 The D.C. voltage shall be obtained normally after necessary rectification by battery charger. The Battery Charging system shall be capable of meeting the following requirements :
- 13.01.04 Float charging the Battery.
- 13.01.05 Boost Charging the Battery.
- 13.01.06 The battery shall be large enough to crank the engine **3** times without charging in between and without getting drained to an extent which will affect its life.
- 13.01.07 The Bidder shall indicate the battery voltage and battery capacity in Ampere- Hour at ten (10) hour discharge rate. The battery voltage at any time during operation shall not be less than the minimum voltage required for operation of the D.C. loads.

##### 13.02.00 General Design

The Battery shall be located indoor

#### 13.02.01 **Battery**

- (i) The cells shall be lead-acid type. The Battery shall be automotive type.
- (ii) The cells shall be sealed in type with anti-splash type vent plug.
- (iii) The cell terminal posts shall be provided with connector bolts and nuts, effectively coated with lead to prevent corrosion. Lead or lead coated copper connectors shall be furnished to connect up cells of battery set.
- (iv) Positive and Negative terminal posts shall be clearly and indelibly marked for easy identification.
- (v) The electrolyte shall be of battery grade Sulphuric Acid conforming to IS : 226-2962. Water for storage batteries conforming to IS : 1069 shall be used in the preparation of the electrolyte.

#### 13.02.02 **Battery Charger**

- (i) The Bidder shall furnish the battery charging scheme complete with all necessary accessories such as transformers, switches, fuses, starters, contactors, diodes, ammeters, voltmeters and other devices as required for trouble free operation. All devices and equipment shall conform to relevant Indian Standard or shall be Superior to it.
- (ii) The scheme of the battery charger shall be such that the battery can be charged automatically as well as manually.
- (iii) The boost charger shall have sufficient capacity to restore a fully discharged Battery to a state of full charge in eight (8) hours with some spare margin over maximum charging rate. Suitable provision shall be kept so that, for a particular engine, any of the two (2) charger units can be used for charging any of the two (2) batteries.
- (iv) The instruments, switches and lamps shall be flush/semi-flush mounted on the front panel. Name plate of approved type shall be provided for each of these equipment.
- (v) The panel shall be complete with internal wiring and input-output terminal block. Terminal blocks shall be clip on type of suitable rating. All equipment and wire terminals shall be identified by symbols corresponding to applicable schematic/wiring diagram.

- (vi) Space heaters of adequate capacity shall be provided to prevent moisture condensation in the panel.

### 13.03.00 **Testing**

- 13.03.01 The Battery Charger shall also be subjected to the following tests at manufacturer's works as per IS - 4540
- 13.03.02 Insulation test.
- 13.03.03 Connection checking.
- 13.03.04 Measurement of voltage regulation.
- 13.03.05 Auxiliary of devices.
- 13.03.06 Alternating current measurement.
- 13.03.07 Performance test.
- 13.03.08 Temperature rise test.
- 13.03.09 Following acceptance tests shall be carried out in batteries as per IS:1651.
- a) Marking and packing
  - b) Verification of dimensions
  - c) Test for capacity
  - d) Test for voltage during discharge

Battery and battery charger shall be checked for auto charging and providing sufficient power for three consecutive starting kicks to diesel engine within five minutes with A.C. supply switched off.

## 14.00.00 **CONTROL & ANNUNCIATION PANELS**

### 14.01.00 **Intent of Specification**

The following requirement shall be applicable to the control and annunciation panels furnished under these specifications.

### 14.02.00 **General Information**

- 14.02.01 The equipment specified herein are required for controlling, metering, monitoring and indication of electrical systems of the plant offered.

14.02.02 The selection and design of all the equipment shall be so as to ensure reliable and safe operation of the plant and shall be subjected to approval by the Employer.

14.02.03 The reference ambient temperature outside the panel shall be taken as 50°C and relative humidity 100%.

#### 14.03.00 **Equipment to be Furnished**

Control & annunciation panels shall be furnished complete with all accessories and wiring for safe and trouble free operation of the plant. Details are included in sub-section General.

#### 14.04.00 **Constructional Details**

14.04.01 The panel frames shall be fabricated using suitable mild steel structural sections or pressed and shaped cold-rolled sheet steel of thickness not less than 2.5 mm. Frames shall be enclosed in cold-rolled sheet steel of thickness not less than 1.6 mm. Stiffeners shall be provided wherever necessary.

14.04.02 Panels shall be of free standing type and shall be provided with hinged door with locking arrangement. The access doors, cutest and covers shall be equipped with neoprene/synthetic rubber gaskets (conforming to IS 11149-1984) all around and the latches sufficiently strong to hold them in alignment when closed. The panels to be installed outdoor or semi outdoor shall have a degree of protection of IP:55 and those installed indoor shall have a degree of protection of IP:52 as per IS:13947 Part-1.

14.04.03 If a panel consists of a number of panels, each panel should be mounted side by side and bolted together to form a compact unit, when two panels meet, the joints shall be smooth, close fittings and un-obstructive.

14.04.04 Removable eye bolt or lifting lugs shall be provided on all panels to facilitate easy lifting.

14.04.05 The heights of all operating equipment on the panel shall be between 800 mm to 1600 mm from the finished floor level. The proper supporting arrangement shall be provided by the Contractor.

14.04.06 Cable entries to the panel may be from bottom or top. The cable entry required will be intimated to the successful Bidder. A suitable removable gland plate of 3 mm thick shall be mounted not less than 200 mm above the floor level.

14.04.07 All equipment mounted on the front face of the panels shall be flush or semi-flush type. All equipment shall be so located that their terminal

and adjustment are readily accessible for inspection or maintenance and their removal and replacement can be done without interruption of service to other equipment. The contractor shall submit the panel general arrangement drawings clearly bringing out internal mounting details, dimensions of equipment, clearance between the equipment and the edges of the panel, for approval.

#### 14.05.00 **Name Plates and Labels**

- 14.05.01 Each panel shall be provided with prominent, engraved identification plates for all front mounted equipment. Panel identification name plate shall be provided at front and rear as required.
- 14.05.02 All name plates shall be of non-rusting metal or 3 ply lamicold, with white engraved lettering on black background. Inscription and lettering sizes shall be subjected to Employer's approval.
- 14.05.03 Suitable plastic sticker labels shall be provided for easy identification of all equipment located inside the panel. These labels shall be positioned so as to be clearly visible and shall give the device number, as mentioned in the wiring drawings.

#### 14.06.00 **AC/DC Power Supply**

- 14.06.02 The Employer will provide one feeder each for AC and DC to the panel. The Contractor shall make for his own arrangements for providing these power supplies to different panels.
- 14.06.02 The Contractor shall provide suitable isolating switch fuse unit in the control panel for receiving the above incoming AC and DC supplies. Fuse and link shall be provided for isolating of individual circuit without disturbing other circuits.

#### 14.07.00 **Wiring**

- 14.07.01 All inter panel wiring and connections between panels (if there is group of panels) including all bus wiring for AC & DC supplies shall be provided by the Contractor.
- 14.07.02 All internal wiring shall be carried out with 1100 V grade, single core, 1.5 square mm or larger stranded copper wires having colour-coded PVC insulation. CT circuits shall be wired with 2.5 square mm copper wires, otherwise similar to the above.
- 14.07.03 Extra-flexible wire shall be used for wiring to devices mounted on moving parts such as doors.
- 14.07.04 Spare contacts of auxiliary relays, timers and switches shall be wired out to the terminal blocks as required by the Employer/Engineer at the time of detailed engineering.

#### 14.08.00 **Terminal Blocks**

14.08.01 Terminal Blocks shall be of 650V grade, rated for 10 Amps and in one-piece moulding. It shall be complete with insulating barriers, clip-on-type terminals, and identification strips. Marking on terminal strip shall correspond to the terminal numbering on wiring diagrams. It shall be similar to 'Elmex-Standard' type terminals.

14.08.02 Terminal blocks shall be arranged with at least 100 mm clearance between two sets of terminal block.

14.08.03 The terminal blocks shall have at least 20% spare terminals.

#### 14.09.00 **Grounding**

A continuous copper bus 25 x 3 mm size shall be provided along the bottom of the panel structure. It shall run continuously throughout the length of the panel and shall have provision at both ends for connection to the station grounding grid (25 x 6 mm MS Flat).

#### 14.10.00 **Space Heater and Lighting**

14.10.01 Space heaters shall be provided in the panels for preventing harmful moisture condensation.

14.10.02 The space heaters shall be suitable for continuous operation on 240V AC, 50 Hz, single phase supply and shall be automatically controlled by thermostat. Necessary isolating switches and fuses shall also be provided.

14.10.03 Free standing panel shall have a 240V AC, plug point and a fluorescent light operated by door switch.

#### 14.11.00 **Control and Selector Switches**

14.11.01 Control and selector switches shall be of rotary type, with escutcheon plates clearly marked to show the function and positions.

14.11.02 Control/selector switches shall be spring return or stay put type as per the requirements. Handles of control/selector switches shall be black in colour. Shape and type of handles shall be to the approval of the Employer.

14.11.03 The contact ratings shall be at least the following :

- i) Make and carry continuously      10 Amp.
- ii) Breaking current at 240V DC      1Amp. (Inductive)

iii) Breaking current at 240V DC 5 Amp. at 0.3 p.f. lagging

#### 14.12.00 **Push Buttons**

14.12.01 Push buttons shall be spring return, push to actuate type and rated to continuously carry and break 10A at 240V AC and 0.5A (Inductive) at 220V DC. The push buttons shall have at least 1 NO and 1 NC contact. All contact faces shall be of silver or silver alloy.

14.12.02 All push buttons shall be provided with integral escutcheon plates marked with its function.

14.12.03 The colour of buttons shall be as follows :

Green For motor START, Breaker CLOSE, Valve/ damper OPEN.

Red For motor TRIP, Breaker OPEN, Valve/ damper CLOSE.

Black For all annunciation functions, overload reset and miscellaneous.

14.12.04 Red push buttons shall always be located to the left of green push buttons. In case of clinker grinder etc. the push buttons would be black-red-green from left to right.

#### 14.13.00 **Indicating Lamps**

14.13.01 Indicating lamps shall be of the panel mounting, filament type and of low-watt consumption. Lamps shall be provided with series resistors preferably built-in- the lamps assembly. The lamps shall have escutcheon plates marked with its function, wherever necessary.

14.13.02 Lamp shall have translucent lamp covers of the following colours :

Red for motor OFF, Valve/damper OPEN, Breaker CLOSED.

Green for motor ON, Valve/damper CLOSED, Breaker OPEN.

White for motor AUTO-TRIP.

Blue for all healthy conditions (e.g. control supply, lub oil pressure and also for spring charged).

Amber for all ALARM conditions (e.g. pressure low, over load and also for 'service' and 'Test' position indication).

14.13.03 Bulbs and lamps covers shall be easily replaceable from the front of the panel.

14.13.04 Indicating lamps should be located directly above the associated push

button/control switches. Red lamps shall variably be located to the right of the green lamp. In case a white lamp is also provided, it shall be placed between the red and green lamps. Blue and amber lamps should normally be located above the red and green lamps.

#### 14.14.00 **Fuses**

- 14.14.01 All fuses shall be of HRC cartridge plug-in-type and shall be of suitable rating, depending upon circuit requirements.
- 14.14.02 All fuses shall be mounted on fuse carriers, which shall be mounted on fuse-bases.

#### 14.15.00 **Contactors**

- 14.15.01 Contactors shall be of air break, electromagnetic type rated as per requirement. These shall be of utilisation category AC 3 as per IS:2959.
- 14.15.02 Operating coils of AC contactors shall be of 240V AC or 220V DC as required. AC contactors shall operate satisfactorily between 85% to 110% of the rated voltage. The Contactor shall not drop out at 70% of the rated voltage.
- 14.15.03 DC contactors shall have a coil voltage of 220V DC and shall be suitable for satisfactory continuous operation at 80% to 110% of the rated voltage.

#### 14.16.00 **Relays and Timers**

- 14.16.01 All auxiliary relays & timers shall be of proven design and of reputed make. Contacts of relays and timers shall be of solid silver or silver cadmium oxide or solid silver faced. Timers shall have the provision to adjust the delay on pick-up or reset as required.
- 14.16.02 All relays and timers shall have at least two NO and two NC contacts.
- 14.16.03 All relays and timers shall be suitable for 240V AC and 220V DC as required. DC relays shall operate satisfactorily between 70% to 110% and AC relays shall be suitable for voltage variation between 80% to 110%.

#### 14.17.00 **Indication Instruments**

- 14.17.01 All indicating and integrating meters shall be flush mounted on panel front. The instruments shall be of at least 96 mm square size with 90 degree scales and shall have an accuracy class of 2.0 or better. The covers and cases of instruments and meters shall provide a dust and vermin proof construction.
- 14.17.02 All instruments shall be compensated for temperature errors and factory

calibrated to directly read the primary quantities. Means shall be provided for zero adjustment removing or dismantling the instruments.

14.17.03 All instruments shall have white dials with black numerals and lettering. Black knife edge pointer with parallax free dials will be preferred.

14.17.04 Ammeters provided on motor feeders shall have a compressed scale at the upper current region to cover the starting current.

#### 14.18.00 **Annunciation System**

14.18.01 The annunciation system shall be complete with all necessary relays, flashers and other accessories required for the proper operation of the equipment and shall be completely solid state. The control circuit shall be mounted on plug-in type glass epoxy printed circuit boards. Audible alarms for the system shall be mounted inside the panel. One set of acknowledge, test and reset push buttons shall be mounted on the panel.

14.18.02 Indications shall be engraved on Acrylic inscription plate window and shall be visible clearly when the indication lamp is lighted (black letters on white background). Each window shall be provided with two lamps.

14.18.03 Audible hooter shall sound when a trouble contact operates and shall continue to sound until the acknowledge button is pressed. In addition to the hooters provided on annunciation panels, a hooter shall be provided outside FFPH which shall sound in any fire alarm condition.

14.18.04 Indication lamps shall flash when trouble contact operates and shall continue flashing until acknowledge button is pressed.

14.18.05 After acknowledge button is pressed, the hooter and flashing shall stop but the indication lamp shall remain lighted.

14.18.06 After trouble is cleared indication lamps shall be ready and shall go off only when reset.

14.18.07 Silencing the hooter in conjunction with one trouble contact shall not stop and hooter sounding if another trouble contact operates.

14.18.08 When test button is pressed, all lamps shall flash and hooter shall sound.

14.18.09 Annunciator systems shall operate on 220V DC Systems.

14.18.10 The annunciation system shall include alarm for AC control system failure (working on DC supply), DC supply failure (working on AC supply) and test facilities for these alarms.

14.18.11 List of annunciations required on the panels has been listed elsewhere.

The Contractor shall also provide additional annunciations if desired by the Employer/Engineer during Vendor drawing review stage and for such additional annunciations no extra charges shall be claimed by the Contractor, if the number of such additions are within 10% of the number stipulated in this specification.

14.18.12 20% spare windows shall be provided on the panel.

#### 14.19.00 **Painting**

14.19.01 **Painting procedure adopted shall conform to requirements given in GTR. The paint thickness shall not be less than 60 microns.** Finished parts shall be coated by peelable compound by spraying method to protect the finished surface from scratches, grease, dirt and oily spots during testing, transportation handling and erection.

#### 14.20.00 **Tests**

14.20.01 Following tests/inspection shall be carried out by the Contractor in the presence of Employer's representative :

##### (A) Factory Tests

1. Compliance with approved drawings, data and specification.
2. Visual check for workmanship.
3. Wiring continuity and functional checks.
4. Calibration of instruments, relays and metres wherever required by inspector.
5. HV test
6. Insulation resistance measurement before and after HV test.

##### (B) Inspection/Testing at site :

1. IR test before and after HV test
2. HV Test
3. Functional Testing.

##### (C)

1. The Fire detection and annunciation panel shall be subjected to functional tests.
2. The Annunciation System shall be routine tested

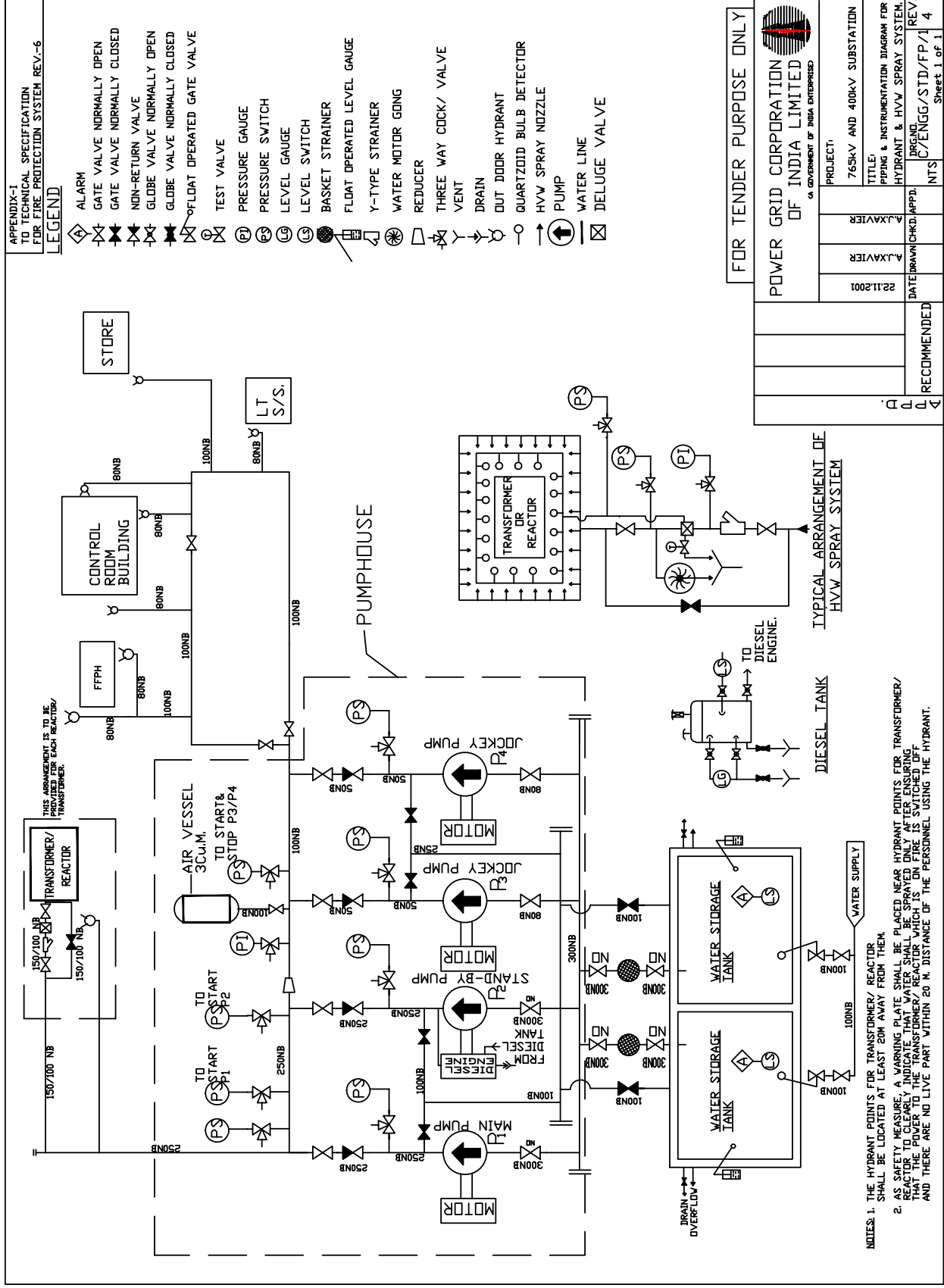

APPENDIX-II  
TO TECHNICAL SPECIFICATION  
FOR FIRE PROTECTION SYSTEM REV.-6

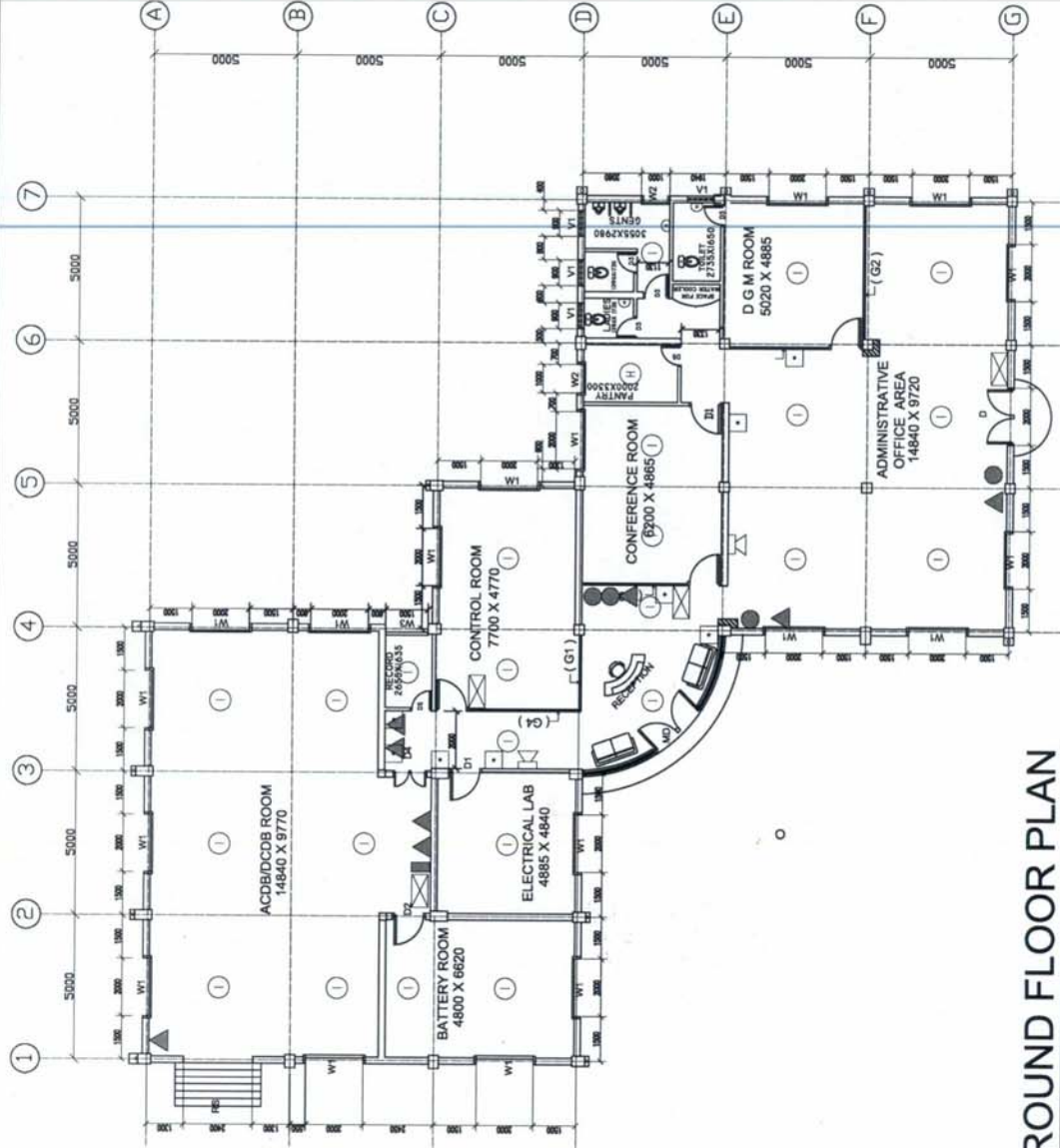

**GROUND FLOOR PLAN**

BILL OF QUANTITY FOR FIRE EXTINGUISHERS.		
SYMBOL	TYPE	QUANTITY
▲	4.5 KG CO2	08+1*
●	9 LITRE WATER	04
■	5 KG DCP	01+4*

\* FOR FIRE WATER PUMP HOUSE AND DG SET.

BILL OF QUANTITY FOR FIRE DETECTORS.		
SYMBOL	ITEM	QUANTITY
⊖	IONIZATION DETECTORS	24
⊕	HEAT DETECTOR	01
⊙	REMOTE RESPONSE INDICATOR	08
⊗	MANUAL CALL POINT	04
⊠	HOOTER	02+1#

# FOR FIRE WATER PUMP HOUSE.

NOTES :-  
ALL DIMENSIONS ARE IN MM. UNLESS OTHERWISE SPECIFIED.



PROJECT :	800/400/220 KV SUB-STATION
TITLE :	STANDARD CONTROL ROOM BUILDING LOCATION OF DETECTORS AND PORTABLE EXTINGUISHERS
DRAWING NO.	C-ENG/CRB-400/FP-STD-02
SCALE	1:100
REV.	0

REV.	DESCRIPTION	CIVIL	MECH.	ELEC.	HYD.	DATE





APPENDIX-III (SHEET 3 OF 4)  
TO TECHNICAL SPECIFICATION  
FOR FIRE PROTECTION SYSTEM REV.-6

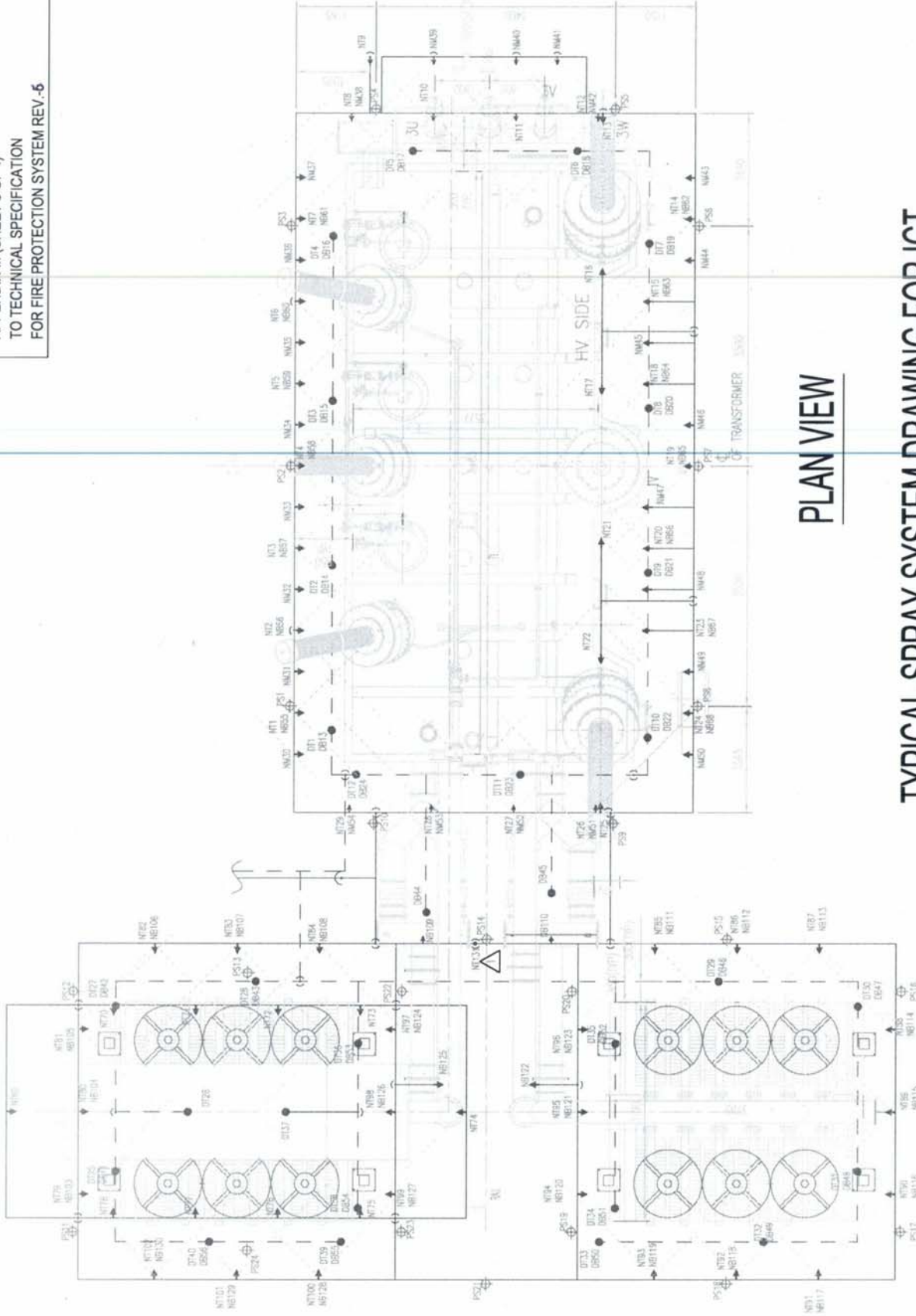

PLAN VIEW

TYPICAL SPRAY SYSTEM DRAWING FOR ICT

APPENDIX-III (SHEET 4 OF 4)  
TO TECHNICAL SPECIFICATION  
FOR FIRE PROTECTION SYSTEM REV-6

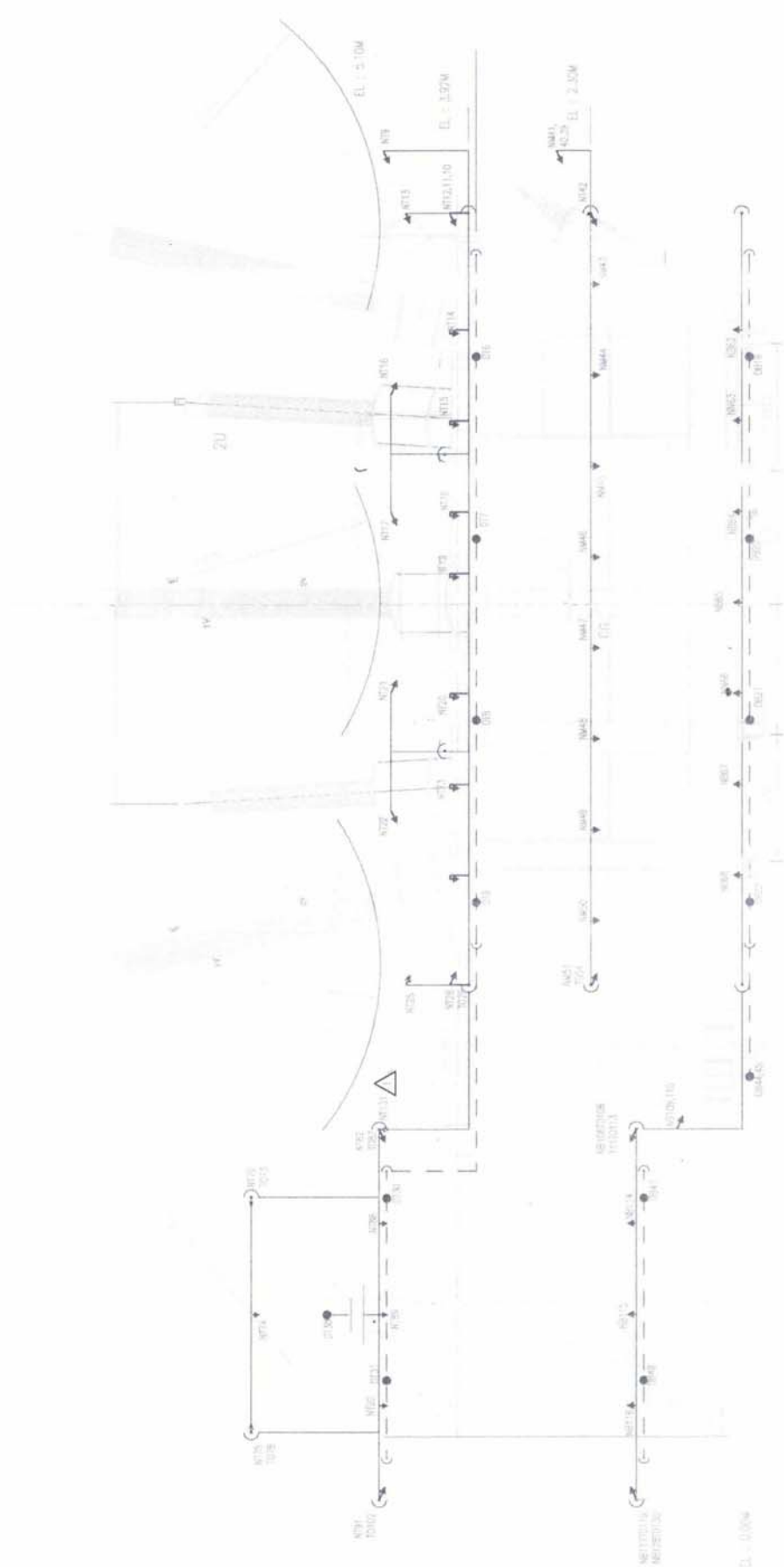

**ELEVATION**  
**TYPICAL SPRAY SYSTEM DRAWING FOR ICT**

**TECHNICAL DATA SHEETS**

<b><u>DATA SHEET FOR DELUGE VALVE</u></b>		
1.0	Manufacturer	POWERGRID Approved make
2.0	Number & size	As per approved system drawings.
3.0	Type	Differential Diaphragm type.
4.0	Rating	
4.1	Flow in M <sup>3</sup> /hr. 1. 150 mm ø 2. 100 mm ø	170 to 650 50 to 225
4.2	Pressure	Working Pressure – 12.3 kg/cm <sup>2</sup> Test Pressure - 25 kg/cm <sup>2</sup> .
4.3	Pressure drop in equivalent length 1. 150 mm ø 2. 100 mm ø	19M 11M
5.0	<b>Material of construction</b>	
5.1	Body	CI IS:210 Gr. FG 260
5.2	Valve internal	Cast Bronze – IS:318-LTB 2
5.3	Seat Seal	Neoprene Rubber
5.4	Diaphragm	Neoprene Rubber
6.0	Differential pressure required for operation	Differential Ratio – 50%
7.0	Water Motor Gong provided	Yes
7.1	Type	Hydraulic type
7.2	<b>Material of Construction:</b>	
7.2.1	Housing	Al. Alloy-IS:617
7.2.2	Cover/Rotor./Gong	Aluminium to IS:737
7.2.3	Manual actuation lever provided?	Yes
8.0	Remote actuation with Solenoid Valve provided?	Yes
9.0	Resetting type	Manual resetting type
10.0	Deluge valve complete with test and drain valves, manual operation arrangement, supporting structures and all necessary accessories.	Yes
11.0	Approval of Deluge Valve.	FM of USA, UL of USA, LPCB of U.K. or VDS of Germany

**DATASHEET FOR HVW SPRAY NOZZLE**

1.0	Make	POWERGRID Approved make
2.0	Type	High velocity water spray type
3.0	Working pressure	3.5 bar to 5 bar
4.0	Material	Brass
5.0	K factor	As per approved design & drawings
6.0	Quantity	As per approved design & drawings
7.0	Integral non-ferrous strainer provide	Yes
8.0	Approval of HVW spray Nozzle.	FM of USA, UL of USA, LPCB of U.K. or VDS of Germany

**DATA SHEET FOR QUARTZOID BULB DETECTORS**

1.0	Make	POWERGRID Approved make
2.0	Type	Quartzoid bulb type
3.0	Rated pressure	12.3 kg/ cm <sup>2</sup> (175 PSI).
4.0	Hydrotest pressure	30kg/cm <sup>2</sup>
5.0	Material of construction	
5.1	Frame	Bronze
5.2	Bulb	Glass
5.3	Deflector	Copper
6.0	Temperature rating	79°C
7.0	Quantity	As per approved drawings
8.0	Approval of Detector	FM of USA, UL of USA, LPCB of U.K. or VDS of Germany

**DATA SHEET FOR OPTICAL SMOKE DETECTOR**

1.0	Manufacturer	POWERGRID Approved make
2.0	Principle of operation	Light scattering by smoke particles.
3.0	Max. recommended spacing	9 m.
4.0	Normal operating temperature	-10°C to 60°C
5.0	Guaranteed to function properly without any maintenance work for a period of not less than ten (10) years	Yes. Accumulated dust to be removed periodically by blowing air.
6.0	Approval of detector	FM of USA, UL of USA, LPCB of U.K. or VDS of Germany
7.0	Cabling.	2C x 1.5 sq.mm. Un-armoured PVC insulated FR cables conforming to IS 1554 (Part 1).

**DATA SHEET FOR HEAT DETECTOR**

1.0	Manufacturer	POWERGRID Approved make
2.0	Principle of operation	Rate of rise-cum-fixed temperature type.
3.0	Set point of operation	5°C per minute / 55°C
4.0	Max. recommended spacing	6 m.
5.0	Normal operating temperature	-20°C to 70°C
6.0	Guaranteed to function properly without any maintenance work for a period of not less than ten (10) years	Yes. Accumulated dust to be removed periodically by blowing air.
7.0	Approval of detector	FM of USA, UL of USA, LPCB of U.K. or VDS of Germany
8.0	Cabling.	2C x 1.5 sq.mm. Un-armoured PVC insulated FR cables conforming to IS 1554 (Part 1).

**DATA SHEET FOR IONISATION SMOKE DETECTOR**

1.0	Manufacturer	POWERGRID Approved make
3.0	Principle of operation	Ionisation of air by Radio-active source.
4.0	Radio-active source	Americium - 241
5.0	Max. recommended spacing	9 m.
6.0	Normal operating temperature	-10°C to 60°C
8.0	Guaranteed to function properly without any maintenance work for a period of not less than ten (10) years	Yes. Accumulated dust to be removed periodically by blowing air.
9.0	Approval of detector	FM of USA, UL of USA, LPCB of U.K. or VDS of Germany
10.0	Cabling.	2C x 1.5 sq.mm. Un-armoured PVC insulated FR cables conforming to IS 1554 (Part 1).

<b><u>DATA SHEET FOR 2C x 1.5sq.mm Un-armoured cable.</u></b>		
1	Make	POWERGRID approved make
2	Type	Control Cable
3.	Number of cores	Two (2)
4.	Size	1.5 sq. mm.
5.	Voltage Grade	1.1 kV
6.	Applicable standard	IS:1554 Part 1
7.	Conductor Material	Plain annealed electrolytic copper
8.	Conductor construction	Stranded
9	Conductor resistance.	12.1 Ohms/kM at 20° C
10	Insulation material	PVC insulation Type A as per IS:5831
11	Insulation thickness	0.8 mm Nominal
12	Identification	Red & Black
13	Inner sheath material	PVC compound Type ST1 as per IS:5831
14	Inner sheath thickness	0.3 mm Minimum
15	Outer sheath material	PVC compound Type ST2 as per IS:5381,FR.
16	Outer sheath thickness	1.8 mm Nominal.
17	outer sheath colour	Grey
18	Overall Diameter	As per manufacturer design data

**DATA SHEET FOR MANUAL CALL POINT**

1.0	Manufacturer	POWERGRID Approved make
2.0	Construction	Deep drawn sheet steel
3.0	Type	Break glass with push button.
4.0	Operating Voltage	24V DC $\pm$ 10%
5.0	Type of control	Pole- NO/NC
6.0	Degree of protection	IP 52
7.0	Material of housing.	M.S. 18 Gauge
8.0	Colour	FIRE RED
9.0	Accessories	Hammer & Chain assembly

**DATA SHEET FOR FIRE ALARM SOUNDER (HOOTER)**

1.0	Manufacturer	POWERGRID Approved make
2.0	Construction	Deep drawn sheet steel
3.0	Type	Dual tone/ Single tone
4.0	Operating Voltage	24V DC $\pm$ 10%
5.0	Output	Not less than 80dB(A) but not more than 120dB(A) at 1.5m distance.
6.0	Output frequency range	500Hz. to 1000 Hz.
7.0	Operating time	50 minutes (Minimum)
8.0	Material of housing.	M.S. 18 Gauge
9.0	Colour	FIRE RED
10.0	Marking	FIRE ALARM.

<b><u>DATA SHEET FOR GLOBE VALVE.</u></b>		
1.0	Nominal size in mm.	15 TO 40
2.0	Make	POWERGRID approved make
3.0	Type	Globe
4.0	Number	As per approved system drawings.
5.0	<b>Material of construction</b>	
5.1	Body	Bronze to IS 318 Grade LTB 2
5.2	Hand wheel	Grey cast iron, grade FG200 of IS 210.
5.3	Bonnet & Bonnet Wedge	Bronze to IS 318 Grade LTB 2
5.4	Trim	Bronze to IS 318 Grade LTB 2
6.0	End connection	Screwed
7.0	Standard	IS:778
8.0	Rating	PN 1.6
9.0	Hydrostatic test pressure	
9.1	Body	24 kg/cm <sup>2</sup>
9.2	Seat	16 kg/cm <sup>2</sup>

<b><u>DATA SHEET FOR GUN METAL GATE/ SLUICE VALVE.</u></b>			
1.0	Nominal size in mm.	15 to 40	50 to 300
2.0	Make	POWERGRID Approved make	
3.0	Type	Gate/Sluice	
4.0	Number	As per approved system drawings.	
5.0	<b>Material of construction</b>		
5.1	Body	Bronze to IS 318 Grade LTB 2	Grey cast iron, grade FG200 of IS 210.
5.2	Hand wheel	Grey cast iron, grade FG200 of IS 210.	
5.3	Bonnet & Wedge	Bronze to IS 318 Gr.LTB 2	Grey cast iron, grade FG200 of IS 210.
5.4	Stem	High tensile brass, grade HT1 or HT2 of IS:320	Stainless steel
6.0	End connection	Screwed	Flanged
7.0	Standard	IS:778	IS:14846
8.0	Rating	PN 1.6	
9.0	Hydrostatic test pressure		
9.1	Body	24 kg/cm <sup>2</sup>	
9.2	Seat	16 kg/cm <sup>2</sup>	

Appendix-IV  
Sheet 12 of 13

<b><u>DATA SHEET FOR FLOAT OPERATED VALVE</u></b>		
1.0	Manufacturer	POWERGRID Approved make
2.0	Type	Float operated valve
3.0	Size	100 MM
4.0	Quantity	2 nos.
5.0	Material of construction	
5.1	Body	Cast Iron (IS:210 FG:200)
5.2	Seat Ring	Gun Metal (IS:318, LTB-2)
5.3	Disc Ring	Gun Metal (IS:318, LTB-2)
5.4.	Spindle	13% Cr. Stainless steel
5.5	Piston	Cast Iron (IS:210, FG:200)
5.6	Lever	Mild Steel (IS:226)
5.7	Float	Tin Coated Copper
5.8	Fulcrum	Mild Steel (IS:226)
5.9	Pilot Valve	Stainless Steel (AISI-304)
5.10	Gland Packing	Graphited Asbestos Rope
5.11	Bonnet	Cast Iron (IS:210, FG:200)
6.0	Hydrostatic test pressure	
6.1	Body	15 kg / cm <sup>2</sup>
6.2	Seat	10 kg / cm <sup>2</sup>
7.0	End connection	Flanged connection

<b><u>DATA SHEET FOR CHECK VALVES (NON-RETURN VALVES)</u></b>		
1.0.0	Make	POWERGRID Approved make
1.1.0	Type	Swing Check Type
1.2.0	Standard followed	IS:5312
1.3.0	Rating	PN 1.6
1.4.0	Material of construction, Dimensions.	As per IS;5312
1.5.0	Inlet Outlet details	Flanged
1.6.0	Hydraulic test pressure, kg/cm <sup>2</sup>	
1.6.1	Body	24
1.6.2	Seat	16

**APPENDIX -V**  
**Page 1 of 2**

**VENDOR LIST FOR FIRE PROTECTION PACKAGE**

S.No.	Equipment/Material	Make
1.	Pumps (Horizontal Centrifugal)	KBL/M&P/B&C
2.	Motors (L.T.)	RAJENDRA ELECT.IND./GEC SIEMENS/ ABB/CROMPTON
3.	Diesel Engine	Ruston & Hornsby (Greaves)/ KIRLOSKAR OIL ENGINE LTD
4.	Air Compressor	KGK/ELGI/INGERSOL RAND
5.	Batteries	EXIDE/AMCO/AMARA RAJA
6.	M.S./G.I Pipes	JINDAL/PRAKASH/ SAIL/ LLOYD METALS & ENGINEERS LTD.
7.	C. I. Valves (Gate & Check)	H. Sarkar/Venus/Kalpana
8.	Gun Metal Valves (Globe)	Leader
9.	Float operated Gate Valve	Levcon/Sigma
10.	Deluge Valve	ACE Turnkey/H.D. Fire
11.	Strainer (Y-Type & Basket Type)	Grandprix/Jaypee/Multitex/ Gujarat Otofilt
12.	Hume pipe	Indian Hume Pipe/Pargate Concrete Udyog Delhi
13.	H. V. Spray Nozzles	H.D. Fire/ACE Turnkey
14.	Q. B. Detectors	H.D Fire/ACE Turnkey
15.	Pressure Gauge	H. Guru/General Instrument
16.	Pressure Switches	Indfos/Switzer/Verma Trafag
17.	Level Switches	Levcon/Sigma
18.	Level Indicator	Levcon/Sigma

**APPENDIX -V**  
**Page 2 of 2**

S.No.	Equipment/Material	Make
19.	Level Gauge	Levcon/Sigma
20.	Hydrant Valves & Accessories	Sukan/Shah Bhogilal
21.	Hoses (Flax Canvas)	Jayshree Calcutta/Newage
22.	Solenoid Valves	AVCON/ROTEX
23.	Heat & Smoke Detectors	Apollo, U.K. /Pyrotonics / System Sensor/ Nittan
24.	Cables	Polycab/PRWE/GEMSCAB/ KEI/PARAMOUNT
25.	Fire Extinguishers	Nitin/Vijay Fire/Lightex/ Zenith/ Minimax
26.	Fire alarm Panels	ECD
27.	Annunciators	Peacon/Piri/Procon
28.	Dished Ends	Anoop Engg./Motilal/Kanara
29.	Local control panels & Annunciation panels.	Suchitra/ Vikas Engg./UNILEC/JASPER/ MIKA/ Bose corporation.
30.	Response Indicators/Hooters Break Glass Units	M.C. Engineering Delhi/ Maths, Bombay/ Mehta & Associates, Ahmedabad.

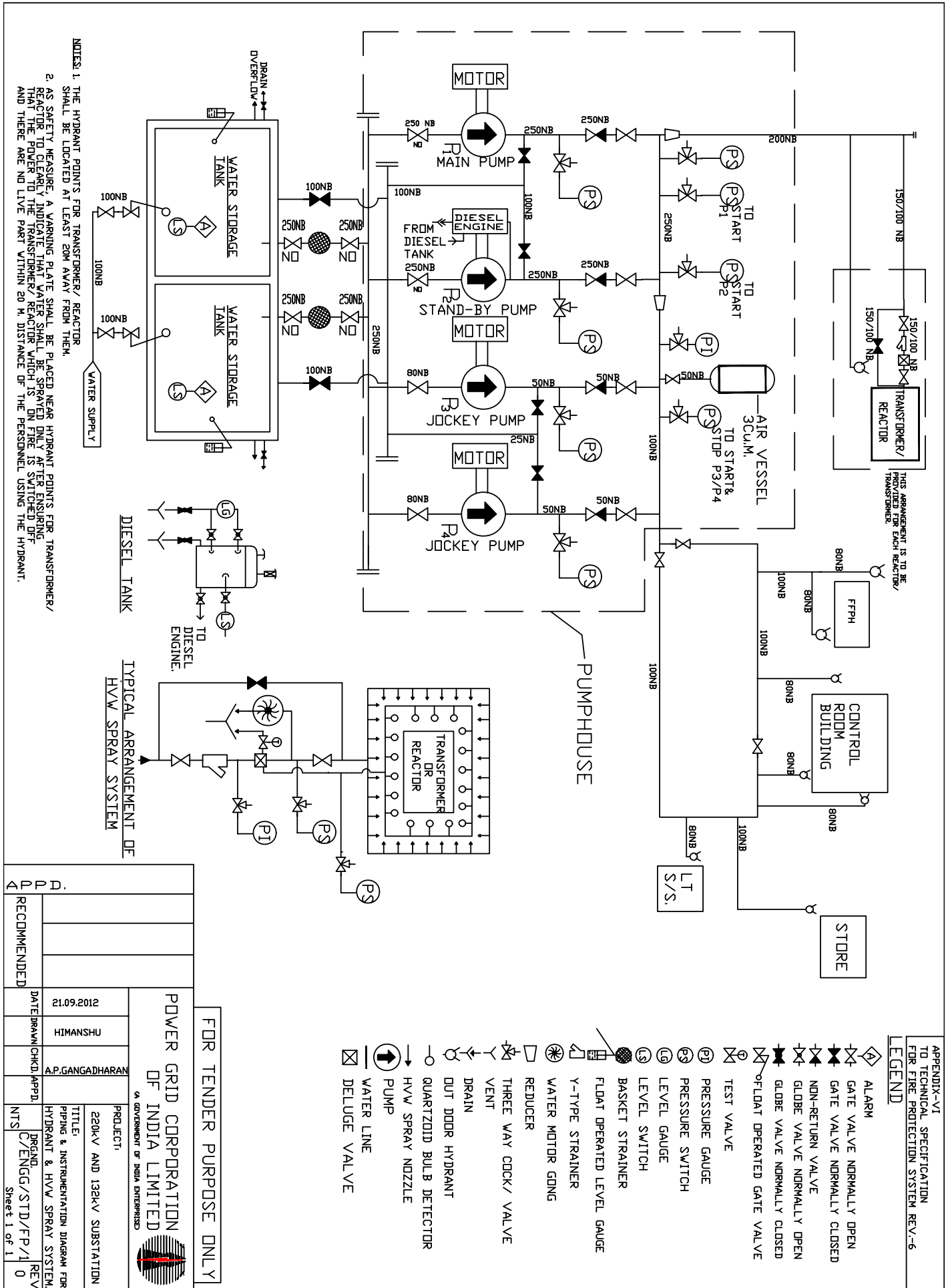

**NOTES:**

1. THE HYDRANT POINTS FOR TRANSFORMER/ REACTOR SHALL BE LOCATED AT LEAST 20M AWAY FROM THEM.
2. AS SAFETY MEASURE, A WARNING PLATE SHALL BE PLACED NEAR HYDRANT POINTS FOR TRANSFORMER/ REACTOR TO CLEARLY INDICATE THAT WATER SHALL BE SPRAYED ONLY AFTER ENSURING THAT THE POWER TO THE TRANSFORMER/ REACTOR WHICH IS ON FIRE IS SWITCHED OFF AND THERE ARE NO LIVE PART WITHIN 20 M. DISTANCE OF THE PERSONNEL USING THE HYDRANT.

**TYPICAL ARRANGEMENT OF HVV SPRAY SYSTEM**

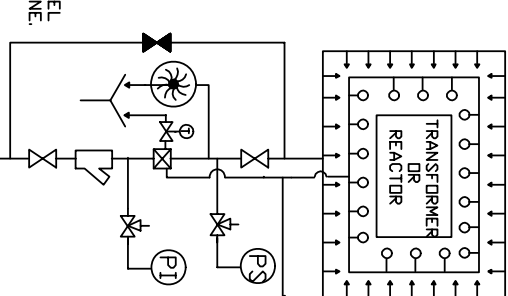

THIS ARRANGEMENT IS TO BE PROVIDED FOR EACH REACTOR/ TRANSFORMER

<b>Project</b>	<b>765/400KV (UPPTCL) NEW SUBSATATION AT AGRA</b>	<b>TB-376-522-01 Rev 00</b>	
<b>System</b>	<b>FIRE FIGHTING SYSTEM</b>		
<b>Owner</b>	<b>UPPTCL</b>		
<b>Customer</b>	<b>POWER GRID CORPORATION OF INDIA LTD</b>		
<b>Purchaser</b>	<b>BHEL (TRANSMISSION BUSINESS GROUP)</b>		

## SECTION-3

## PROJECT DETAILS &amp; GENERAL SPECIFICATION

## SITE INFORMATION

	Particular	Details
a)	Owner	UP POWER TRANSMISSION CORPORATION Ltd
b)	Customer	POWERGRID
c)	Project Title	765kV/400kV Agra UPPTCL (New)Substation
d)	Location	Fatehabad (Agra ) UP
e)	Transport Facilities	RAOD/TRAIN
SITE CONDITIONS		
a)	Max. ambient air temp.	50°C
b)	Min. ambient air temp.	0°C
c)	Max. design ambient temp.	50°C
d)	Design reference temp.	50°C
e)	Average Humidity	Max. 100%
f)	Special corrosion conditions	No
g)	Solar Radiation	1.2kW/sqmtr
h)	Atmospheric UV radiation	High
i)	Altitude above sea level	Less than 1000meter
j)	Pollution Severity	High Pollution level (25mm/kV)
k)	Seismic Zone	As per the seismic zone defined in the relevant BIS but not less than 0.3g horizontal
WIND DATA		
	Wind velocity	As per IS

<b>Project</b>	<b>765/400KV (UPPTCL) NEW SUBSATATION AT AGRA</b>	<b>TB-376-522-01 Rev 00</b>	
<b>System</b>	<b>FIRE FIGHTING SYSTEM</b>		
<b>Owner</b>	<b>UPPTCL</b>		
<b>Customer</b>	<b>POWER GRID CORPORATION OF INDIA LTD</b>		
<b>Purchaser</b>	<b>BHEL (TRANSMISSION BUSINESS GROUP)</b>		

	Average No. of thunderstorm days per annum	As per IS
--	--	-----------

## 1.0 GENERAL

This Chapter covers Technical Requirements and requirements of auxiliary items.

- Equipment furnished shall be complete in every respect with all mountings, fittings, fixtures and standard accessories normally provided with such equipment and/or needed for erection, completion and safe operation of the equipment as required by applicable codes unless included in the list of exclusions.
- Material and components not specifically stated in this specification but which are necessary for satisfactory operation of the equipment and accessories specified in this specification shall be deemed to be included unless specifically excluded and shall be supplied at no extra cost.
- Whenever a material or article is specified or described by the name of a particular brand, manufacturer or vendor, the specific name mentioned shall be understood as establishing type, function and quality and not as limiting competition.
- In case any Deviation Schedule, Bid Proposal Sheet, Schedule of Data Requirements (DRS), test reports or any other document/information are not furnished along-with the bid, the bid is liable to be rejected. Unless brought out clearly, the Bid will be deemed to conform to the specification scrupulously. All deviations from the specification shall be clearly brought out in the respective deviation schedule.

Auxiliary supplies as described below would be available at site.

Normal Voltage (Volts)	Variation in voltage (Hz)	Frequency	Phase	Neutral connection
415	+ 10 %	50 + 5 %	3 Ph- 4wire	Solidly earthed
240	+ 10 %	50 + 5 %	1 Ph-2wire	Solidly earthed
220	+ 10 %	DC		Isolated(2 wire system)
48		DC		Isolated(2 wire system) (+ Earthed)

<b>Project</b>	<b>765/400KV (UPPTCL) NEW SUBSATATION AT AGRA</b>	<b>TB-376-522-01 Rev 00</b>	
<b>System</b>	<b>FIRE FIGHTING SYSTEM</b>		
<b>Owner</b>	<b>UPPTCL</b>		
<b>Customer</b>	<b>POWER GRID CORPORATION OF INDIA LTD</b>		
<b>Purchaser</b>	<b>BHEL (TRANSMISSION BUSINESS GROUP)</b>		

- 
- f) The Bidder shall clearly indicate in the bid, the specific standards in accordance with which the works will be carried out.
  - g) The equipment must be new, of highest grade, the best quality of their kind, to best engineering practice and latest state of art, and in accordance with purpose for which they are intended and ensure satisfactory performance throughout the service life.
  - h) All similar parts of the equipment shall be made to gauge and shall be interchangeable with and shall be made of same materials and workmanship as the corresponding parts of the equipment. Where feasible, common components, units shall be employed in different pieces of equipment in order to optimize the spare part stock-up and utilization.
  - i) The requirement regarding external RIV as specified for equipment shall include the terminal fittings and the equipment shall have been tested preferably with fittings, if any.

#### **2.0 SERVICES TO BE PERFORMED BY THE EQUIPMENT BEING FURNISHED**

- a) The equipment furnished under this specification shall perform all its functions and operate satisfactorily without showing undue strain, restrike etc.
- b) The equipment shall be able to withstand forces due to wind load, short circuit, system over voltages, fluctuations, frequency variations etc., all forces considered together.

#### **3.0 SUPPORT STRUCTURES (If in the scope of Bidder)**

- a) The support structures should be hot dip galvanised with minimum 610 gram/m<sup>2</sup> net of zinc.
- b) The design calculations taking into account the environmental conditions of the substations shall be furnished for sizing of the structures.

#### **4.0 STANDARDS**

- a) The equipment to be furnished under this specification shall conform to latest issue with all amendments of standard specified under respective Chapters of this Specification. The Bidder shall note that standards mentioned in the specification are not mutually exclusive or complete in themselves, but intended to compliment each other. The bidder shall also note that list of standards presented in this specification is not complete. Whenever necessary the list of standards shall be considered in conjunction with specific IS/IEC. When the specific requirements stipulated in the specifications exceed or differ than those required by the applicable standards, the stipulation of the specification shall take precedence.
- b) Other internationally accepted standards which ensure equivalent or better performance than that specified in the standards referred shall also be accepted.

<b>Project</b>	<b>765/400KV (UPPTCL) NEW SUBSATATION AT AGRA</b>	<b>TB-376-522-01 Rev 00</b>	
<b>System</b>	<b>FIRE FIGHTING SYSTEM</b>		
<b>Owner</b>	<b>UPPTCL</b>		
<b>Customer</b>	<b>POWER GRID CORPORATION OF INDIA LTD</b>		
<b>Purchaser</b>	<b>BHEL (TRANSMISSION BUSINESS GROUP)</b>		

- c) In case governing standards for the equipment is different from IS or IEC, the salient points of difference shall be clearly brought out in additional information schedule alongwith English language version of standard or relevant extract of the same. The equipment conforming to standards other than IS/IEC shall be subject to POWERGRID's approval.

## **5.0 ENGINEERING DATA AND DRAWINGS**

- 5.1 The list of drawings/documents which are to be submitted to the Purchaser shall be discussed and finalised by the Purchaser at the time of award. The supplier shall necessarily submit all the drawings/ documents unless anything is waived.
- 5.2 The Contractor shall submit 4 (four) sets of drawings/ design documents /data / detailed bill of quantity and 1 (one) set of test reports for the approval of the Purchaser. The contractor shall also submit the softcopy of the above documents in addition to hardcopy.
- 5.3 Drawings
- 5.3.1 All drawings submitted by the Contractor shall be in sufficient detail to indicate the type, size, arrangement, material description, Bill of Materials, weight of each component, break-up for packing and shipment, dimensions, internal & the external connections, fixing arrangement required and any other information specifically requested in the specifications.
- 5.3.2 Drawings submitted by the Contractor shall be clearly marked with the name of the Purchaser, the unit designation, the specifications title, the specification number and the name of the Project. POWERGRID has standardized a large number of drawings/documents of various make including type test reports which can be used for all projects having similar requirements and in such cases no project specific approval (except for list of applicable drawings alongwith type test reports) is required. However, distribution copies of standard drawings/documents shall be submitted as per provision of the contract. All titles, noting, markings and writings on the drawing shall be in English. All the dimensions should be in SI units.
- 5.3.3 The review of these data by the Purchaser will cover only general conformance of the data to the specifications and documents, interfaces with the equipment provided under the specifications, external connections and of the dimensions which might affect substation layout. This review by the Purchaser may not indicate a thorough review of all dimensions, quantities and details of the equipment, materials, any devices or items indicated or the accuracy of the information submitted. This review and/or approval by the Purchaser shall not be considered by the Contractor, as limiting any of his responsibilities and liabilities for mistakes and deviations from the requirements, specified under these specifications and documents.
- 5.4 All manufacturing and fabrication work in connection with the equipment prior to the approval of the drawings shall be at the Contractor's risk. The Contractor may make any changes in the design which are necessary to make the equipment conform to the provisions and intent of the Contract and such changes will again be

<b>Project</b>	<b>765/400KV (UPPTCL) NEW SUBSATATION AT AGRA</b>	<b>TB-376-522-01 Rev 00</b>	
<b>System</b>	<b>FIRE FIGHTING SYSTEM</b>		
<b>Owner</b>	<b>UPPTCL</b>		
<b>Customer</b>	<b>POWER GRID CORPORATION OF INDIA LTD</b>		
<b>Purchaser</b>	<b>BHEL (TRANSMISSION BUSINESS GROUP)</b>		

subject to approval by the Purchaser. Approval of Contractor's drawing or work by the Purchaser shall not relieve the contractor of any of his responsibilities and liabilities under the Contract.

5.5 All engineering data submitted by the Contractor after final process including review and approval by the Purchaser shall form part of the Contract Document and the entire works performed under these specifications shall be performed in strict conformity, unless otherwise expressly requested by the Purchaser in Writing.

#### 5.7 Approval Procedure

The scheduled dates for the submission of the drawings as well as for, any data/information to be furnished by the Purchaser would be discussed and finalised at the time of award. The following schedule shall be followed generally for approval and for providing final documentation.

- |       |  |   |
|-------|--|---|
| i)    | Approval/comments/<br>Purchaser on initial   | As per agreed by<br>schedule submission               |
| ii)   | Resubmission<br>(whenever<br>required)   | Within 3 (three) weeks<br>from date of comments       |
| iii)  | Approval or comments   | Within 3 (three) weeks of<br>receipt of resubmission. |
| iv)   | Furnishing of distribution<br>copies (5 hard copies per<br>substation and one scanned<br>copy (pdf format) for Corporate<br>Centre)          | 2 weeks from the date<br>of approval                  |
| v)    | Furnishing of distribution copies of test reports  |   |
| (a)   | Type test reports<br>(one scanned softcopy in<br>pdf format per substation plus one for corporate centre<br>& one hardcopy per substation)   | 2 weeks from the date<br>of final approval            |
| (b)   | Routine Test Reports<br>(one copy for each substation)   | -do-  |
| vi)   | Furnishing of instruction/<br>manuals (2 copies<br>per substation and one softcopy<br>(pdf format) for corporate centre<br>& per substation) | As per agreed schedule operation                      |
| (vii) | As built drawings (two sets of<br>hardcopy per substation & one<br>softcopy (pdf format) for<br>corporate centre & per substation)           | On completion of entire works                         |

NOTE :

- (1) The supplier may please note that all resubmissions must incorporate all

<b>Project</b>	<b>765/400KV (UPPTCL) NEW SUBSATATION AT AGRA</b>	<b>TB-376-522-01 Rev 00</b>	
<b>System</b>	<b>FIRE FIGHTING SYSTEM</b>		
<b>Owner</b>	<b>UPPTCL</b>		
<b>Customer</b>	<b>POWER GRID CORPORATION OF INDIA LTD</b>		
<b>Purchaser</b>	<b>BHEL (TRANSMISSION BUSINESS GROUP)</b>		

comments given in the earlier submission by BHEL/POWERGRID or adequate justification for not incorporating the same must be submitted failing which the submission of documents is likely to be returned.

- (2) All drawings should be submitted in softcopy form, however substation design drawings like SLD, GA, all layouts etc. shall also be submitted in AutoCAD Version. SLD, GA & layout drawings shall be submitted for the entire substation in case of substation extension also.
- (3) The instruction Manuals shall contain full details of drawings of all equipment being supplied under this contract, their exploded diagrams with complete instructions for storage, handling, erection, commissioning, testing, operation, trouble shooting, servicing and overhauling procedures.
- (4) If after the commissioning and initial operation of the substation, the instruction manuals require any modifications/ additions/changes, the same shall be incorporated and the updated final instruction manuals shall be submitted by the supplier to BHEL/POWERGRID.
- (5) The manufacturer shall furnish to the Purchaser catalogues of spare parts.
- (6) All As-built drawings/documents shall be certified by site indicating the changes before final submission.

## **6.0 MATERIAL WORKMANSHIP**

### **6.1 General Requirement**

- 6.1.1 Where the specification does not contain references to workmanship, equipment, materials and components of the covered equipment, it is essential that the same must be new, of highest grade of the best quality of their kind, conforming to best engineering practice and suitable for the purpose for which they are intended.
- 6.1.2 In case where the equipment, materials or components are indicated in the specification as "similar" to any special standard, the Purchaser shall decide upon the question of similarity. When required by the specification or when required by the Purchaser the Contractor shall submit, for approval, all the information concerning the materials or components to be used in manufacture. Machinery, equipment, materials and components supplied, installed or used without such approval shall run the risk of subsequent rejection, it being understood that the cost as well as the time delay associated with the rejection shall be borne by the supplier.
- 6.1.3 The design of the Works shall be such that installation, future expansions, replacements and general maintenance may be undertaken with a minimum of time and expenses. Each component shall be designed to be consistent with its duty and suitable factors of safety, subject to mutual agreements. All joints and fastenings shall be devised, constructed and documented so that the component parts shall be accurately positioned and restrained to fulfill their required function. In general, screw threads shall be standard metric threads. The use of other thread forms will only be permitted when prior approval has been obtained from the BHEL/POWERGRID.

<b>Project</b>	<b>765/400KV (UPPTCL) NEW SUBSATATION AT AGRA</b>	<b>TB-376-522-01 Rev 00</b>	
<b>System</b>	<b>FIRE FIGHTING SYSTEM</b>		
<b>Owner</b>	<b>UPPTCL</b>		
<b>Customer</b>	<b>POWER GRID CORPORATION OF INDIA LTD</b>		
<b>Purchaser</b>	<b>BHEL (TRANSMISSION BUSINESS GROUP)</b>		

- 6.1.4 Whenever possible, all similar part of the Works shall be made to gauge and shall also be made interchangeable with similar parts. All spare parts shall also be interchangeable and shall be made of the same materials and workmanship as the corresponding parts of the Equipment supplied under the Specification. Where feasible, common component units shall be employed in different pieces of equipment in order to minimize spare parts stocking requirements. All equipment of the same type and rating shall be physically and electrically interchangeable.
- 6.1.5 All materials and equipment shall be installed in strict accordance with the manufacturer's recommendation(s). Only first-class work in accordance with the best modern practices will be accepted. Installation shall be considered as being the erection of equipment at its permanent location. This, unless otherwise specified, shall include unpacking, cleaning and lifting into position, grouting, levelling, aligning, coupling of or bolting down to previously installed equipment bases/foundations, performing the alignment check and final adjustment prior to initial operation, testing and commissioning in accordance with the manufacturer's tolerances, instructions and the Specification. All factory assembled rotating machinery shall be checked for alignment and adjustments made as necessary to re-establish the manufacturer's limits suitable guards shall be provided for the protection of personnel on all exposed rotating and / or moving machine parts and shall be designed for easy installation and removal for maintenance purposes. The spare equipment(s) shall be installed at designated locations and tested for healthiness.
- 6.1.6 The supplier shall apply oil and grease of the proper specification to suit the machinery, as is necessary for the installation of the equipment. Lubricants used for installation purposes shall be drained out and the system flushed through where necessary for applying the lubricant required for operation. The supplier shall apply all operational lubricants to the equipment installed by him.
- 6.1.7 All oil, grease and other consumables used in the Works/ Equipment shall be purchased in India unless the Contractor has any special requirement for the specific application of a type of oil or grease not available in India. In such is the case he shall declare in the proposal, where such oil or grease is available. He shall help POWERGRID in establishing equivalent Indian make and Indian Contractor. The same shall be applicable to other consumables too.
- 6.1.8 Corona and radio interference voltage test and seismic withstand test (for 132kV and above voltage level) procedures for equipments shall be in line with the procedure given at Annexure-A and B respectively.

## **6.2 Provisions For Exposure to Hot and Humid climate**

Outdoor equipment supplied under the specification shall be suitable for service and storage under tropical conditions of high temperature, high humidity, heavy rainfall and environment favourable to the growth of fungi and mildew. The indoor equipments located in non-air conditioned areas shall also be of same type.

### **6.2.1 Space Heaters**

- 6.2.1.1 The heaters shall be suitable for continuous operation at 240V as supply voltage.

<b>Project</b>	<b>765/400KV (UPPTCL) NEW SUBSATATION AT AGRA</b>	<b>TB-376-522-01 Rev 00</b>	
<b>System</b>	<b>FIRE FIGHTING SYSTEM</b>		
<b>Owner</b>	<b>UPPTCL</b>		
<b>Customer</b>	<b>POWER GRID CORPORATION OF INDIA LTD</b>		
<b>Purchaser</b>	<b>BHEL (TRANSMISSION BUSINESS GROUP)</b>		

On-off switch and fuse shall be provided.

6.2.1.2 One or more adequately rated thermostatically connected heaters shall be supplied to prevent condensation in any compartment. The heaters shall be installed in the compartment and electrical connections shall be made sufficiently away from below the heaters to minimize deterioration of supply wire insulation. The heaters shall be suitable to maintain the compartment temperature to prevent condensation.

6.2.1.3 Suitable anti condensation heaters with the provision of thermostat shall be provided.

#### **6.2.2 FUNGI STATIC VARNISH**

Besides the space heaters, special moisture and fungus resistant varnish shall be applied on parts which may be subjected or predisposed to the formation of fungi due to the presence or deposit of nutrient substances. The varnish shall not be applied to any surface of part where the treatment will interfere with the operation or performance of the equipment. Such surfaces or parts shall be protected against the application of the varnish.

#### **6.2.3 Ventilation opening**

Wherever ventilation is provided, the compartments shall have ventilation openings with fine wire mesh of brass to prevent the entry of insects and to reduce to a minimum the entry of dirt and dust. Outdoor compartment openings shall be provided with shutter type blinds and suitable provision shall be made so as to avoid any communication of air / dust with any part in the enclosures of the Control Cabinets, Junction boxes and Marshalling Boxes, panels etc.

#### **6.2.4 Degree of Protection**

The enclosures of the Control Cabinets, Junction boxes and Marshalling Boxes, panels etc. to be installed shall provide degree of protection as detailed here under:

- a) Installed out door: IP- 55
- b) Installed indoor in air conditioned area: IP-31
- c) Installed in covered area: IP-52
- d) Installed indoor in non air conditioned area where possibility of entry of water is limited: IP-41.
- e) For LT Switchgear (AC & DC distribution Boards) : IP-52

The degree of protection shall be in accordance with IS:13947 (Part-I) / IEC-60947(Part-I) / IS 12063 / IEC-60529. Type test report for degree of protection test, shall be submitted for approval.

### **6.3 RATING PLATES, NAME PLATES AND LABELS**

Each main and auxiliary item of substation is to have permanently attached to it in a conspicuous position a rating plate of non-corrosive material upon which is to be engraved manufacturer's name, year of manufacture, equipment name, type or serial number together with details of the loading conditions under which the

<b>Project</b>	<b>765/400KV (UPPTCL) NEW SUBSATATION AT AGRA</b>	<b>TB-376-522-01 Rev 00</b>	
<b>System</b>	<b>FIRE FIGHTING SYSTEM</b>		
<b>Owner</b>	<b>UPPTCL</b>		
<b>Customer</b>	<b>POWER GRID CORPORATION OF INDIA LTD</b>		
<b>Purchaser</b>	<b>BHEL (TRANSMISSION BUSINESS GROUP)</b>		

item of substation in question has been designed to operate, and such diagram plates as may be required by the Purchaser. The rating plate of each equipment shall be according to IEC requirement.

All such nameplates, instruction plates, rating plates of transformers, reactors, CB, CT, CVT, SA, Isolators, C & R panels and PLCC equipments shall be bilingual with Hindi inscription first followed by English. Alternatively two separate plates one with Hindi and the other with English inscriptions may be provided.

#### **6.4 FIRST FILL OF CONSUMABLES, OIL AND LUBRICANTS**

All the first fill of consumables such as oils, lubricants, filling compounds, touch up paints, soldering/brazing material for all copper piping of circuit breakers and essential chemicals etc. which will be required to put the equipment covered under the scope of the specifications, into successful Operation, shall be furnished by the supplier unless specifically excluded under the exclusions in these specifications and documents.

#### **7.0 DESIGN IMPROVEMENTS / COORDINATION**

- 7.1 The bidder shall note that the equipment offered by him in the bid only shall be accepted for supply. However, the Purchaser or the Contractor may propose changes in the specification of the equipment or quality thereof and if the Purchaser & contractor agree upon any such changes, the specification shall be modified accordingly.
- 7.2 If any such agreed upon change is such that it affects the price and schedule of completion, the parties shall agree in writing as to the extent of any change in the price and/or schedule of completion before the Contractor proceeds with the change. Following such agreement, the provision thereof, shall be deemed to have been amended accordingly.
- 7.3 The supplier shall be responsible for the selection and design of appropriate equipments to provide the best co-ordinated performance of the entire system. The basic design requirements are detailed out in this Specification. The design of various components, sub-assemblies and assemblies shall be so done that it facilitates easy field assembly and maintenance.
- 7.4 The supplier has to coordinate designs and terminations with the agencies (if any) who are Consultants/Contractor for the Purchaser. The names of agencies shall be intimated to the successful bidders.
- 7.5 The supplier will be called upon to attend design co-ordination meetings with the Engineer, other Contractor's and the Consultants of the Purchaser (if any) during the period of Contract. The Contractor shall attend such meetings at his own cost at POWERGRID Corporate Centre, Gurgaon (Haryana) or at mutually agreed venue as and when required and fully cooperate with such persons and agencies involved during those discussions.

#### **8.0 QUALITY ASSURANCE PROGRAMME**

- 8.1 To ensure that the equipment and services under the scope of this Contract whether manufactured or performed within the supplier's Works or at

<b>Project</b>	<b>765/400KV (UPPTCL) NEW SUBSATATION AT AGRA</b>	<b>TB-376-522-01 Rev 00</b>	
<b>System</b>	<b>FIRE FIGHTING SYSTEM</b>		
<b>Owner</b>	<b>UPPTCL</b>		
<b>Customer</b>	<b>POWER GRID CORPORATION OF INDIA LTD</b>		
<b>Purchaser</b>	<b>BHEL (TRANSMISSION BUSINESS GROUP)</b>		

his Sub- contractor's premises or at the Purchaser's site or at any other place of Work are in accordance with the specifications, the supplier shall adopt suitable quality assurance programme to control such activities at all points necessary. The detailed programme shall be submitted by the contractor after the award for reference. A quality assurance programme of the supplier shall generally cover the following:

- (a) His organisation structure for the management and implementation of the proposed quality assurance programme;
- (b) Documentation control system;
- (c) Qualification data for bidder's key personnel;
- (d) The procedure for purchases of materials, parts components and selection of sub-Contractor's services including vendor analysis, source inspection, incoming raw material inspection, verification of material purchases etc.
- (e) System for shop manufacturing and site erection controls including process controls and fabrication and assembly control;
- (f) Control of non-conforming items and system for corrective actions;
- (g) Inspection and test procedure both for manufacture and field activities.
- (h) Control of calibration and testing of measuring instruments and field activities;
- (i) System for indication and appraisal of inspection status;
- (j) System for quality audits;
- (k) System for authorising release of manufactured product to the Purchaser.
- (l) System for maintenance of records;
- (m) System for handling storage and delivery; and
- (n) A quality plan detailing out the specific quality control measures and procedures adopted for controlling the quality characteristics relevant to each item of equipment furnished and/or services rendered.

POWERGRID/BHEL or his duly authorised representative reserves the right to carry out quality audit and quality surveillance of the system and procedure of the supplier/his vendor's quality management and control activities.

## **8.2 Quality Assurance Documents**

The supplier would be required to submit all the Quality Assurance Documents as stipulated in the Quality Plan at the time of POWERGRID/BHEL inspection of equipment/material

## **9.0 TYPE TESTING, INSPECTION, TESTING & INSPECTION CERTIFICATE**

- 9.1 All equipment being supplied shall conform to type tests as per technical specification and shall be subject to routine tests in accordance with requirements stipulated under respective sections.

<b>Project</b>	<b>765/400KV (UPPTCL) NEW SUBSATATION AT AGRA</b>	<b>TB-376-522-01 Rev 00</b>	
<b>System</b>	<b>FIRE FIGHTING SYSTEM</b>		
<b>Owner</b>	<b>UPPTCL</b>		
<b>Customer</b>	<b>POWER GRID CORPORATION OF INDIA LTD</b>		
<b>Purchaser</b>	<b>BHEL (TRANSMISSION BUSINESS GROUP)</b>		

9.2 The reports for all type tests as per technical specification shall be furnished by the supplier alongwith equipment / material drawings. However, type test reports of similar equipments/ material already accepted in POWERGRID shall be applicable for all project with similar requirement. The type tests conducted earlier should have either been conducted in accredited laboratory (accredited based on ISO / IEC Guide 25 / 17025 or EN 45001 by the national accreditation body of the country where laboratory is located) or witnessed by POWERGRID or representative authorized by POWERGRID or Utility or representative of accredited test lab or reputed consultant.

The test reports submitted shall be of the tests conducted within last 10 (ten) years prior to the date of bid opening i.e. 26.08.11. In case the test reports are of the test conducted earlier than 10 (ten) years prior to the date of bid opening, the contractor shall repeat these test(s) at no extra cost to BHEL.

Further, in the event of any discrepancy in the test reports i.e. any test report not acceptable due to any design/manufacturing changes (including substitution of components) or due to non-compliance with the requirement stipulated in the Technical Specification or any/all type tests not carried out, same shall be carried out without any additional cost implication to the Purchaser.

The supplier shall intimate the BHEL/POWERGRID the detailed program about the tests atleast two (2) weeks in advance in case of domestic supplies & six (6) weeks in advance in case of foreign supplies.

Further, in case type tests are required to be conducted/repeated and the deputation of Inspector/Purchaser's representative is required, then all the expenses shall be borne by the supplier.

9.3 The Purchaser intends to repeat the type tests on Power Transformer and Shunt Reactor except Dynamic short circuit tests on transformers, for which test charges shall be payable as per provision of contract. The price of conducting type tests shall be included in Bid price and break up of these shall be given in the relevant schedule of Bid Proposal Sheets. These Type test charges would be considered in bid evaluation. In case Bidder does not indicate charges for any of the type tests or does not mention the name of any test in the price schedules, it will be presumed that the particular test has been offered free of charge. Further, in case any Bidder indicates that he shall not carry out a particular test, his offer shall be considered incomplete and shall be liable to be rejected. BHEL/POWERGRID reserves the right to witness any or all the type tests. The BHEL/POWERGRID also reserves the right to waive the repeating of type tests partly or fully and in case of waiver, test charges for the same shall not be payable.

The Purchaser shall bear all expenses for deputation of purchaser's representative(s) for witnessing the type tests under this clause except in the case of re-deputation if any, necessitated due to no fault of the purchaser.

For outdoor receptacles, trefoil clamps, diesel engine, alternator, motors, cable glands, lighting fixtures, ACSR/AAC conductor, IPS aluminum tube and junction boxes, type test reports are not required to be submitted for the makes

<b>Project</b>	<b>765/400KV (UPPTCL) NEW SUBSATATION AT AGRA</b>	<b>TB-376-522-01 Rev 00</b>	
<b>System</b>	<b>FIRE FIGHTING SYSTEM</b>		
<b>Owner</b>	<b>UPPTCL</b>		
<b>Customer</b>	<b>POWER GRID CORPORATION OF INDIA LTD</b>		
<b>Purchaser</b>	<b>BHEL (TRANSMISSION BUSINESS GROUP)</b>		

indicated at Annexure-E /POWERGRID approved list of subvendors. For the new makes(other than those indicated at Annexure-E / POWERGRID approved list of subvendors), type test reports as per relevant standard shall be submitted for POWERGRID's approval.

- 9.4 The Purchaser, his duly authorised representative and/or outside inspection agency acting on behalf of the Purchaser shall have at all reasonable times free access to the Contractor's/sub-vendors premises or Works and shall have the power at all reasonable times to inspect and examine the materials and workmanship of the Works during its manufacture or erection if part of the Works is being manufactured or assembled at other premises or works, the Contractor shall obtain for the Engineer and for his duly authorised representative permission to inspect as if the works were manufactured or assembled on the Contractor's own premises or works. Inspection may be made at any stage of manufacture, despatch or at site at the option of the Purchaser and the equipment if found unsatisfactory due to bad workmanship or quality, material is liable to be rejected.
- 9.5 The supplier shall give the Purchaser /Inspector fifteen (15) days written notice for on-shore and six (6) weeks notice for off-shore material being ready for joint testing including contractor and POWERGRID. Such tests shall be to the Contractor's account except for the expenses of the Inspector. The Purchaser/inspector, unless witnessing of the tests is virtually waived, will attend such tests within fifteen (15) days of the date of which the equipment is notified as being ready for test/inspection, failing which the Contractor may proceed alone with the test which shall be deemed to have been made in the Inspector's presence and he shall forthwith forward to the Inspector duly certified copies of tests in triplicate.
- 9.6 The Purchaser or Inspector shall, within fifteen (15) days from the date of inspection as defined herein give notice in writing to the Contractor, of any objection to any drawings and all or any equipment and workmanship which in his opinion is not in accordance with the Contract. The Contractor shall give due consideration to such objections and shall either make the modifications that may be necessary to meet the said objections or shall confirm in writing to the Purchaser /Inspector giving reasons therein, that no modifications are necessary to comply with the Contract.
- 9.7 When the factory tests have been completed at the Contractor's or Sub- Contractor's works, the Purchaser/inspector shall issue a certificate to this effect within fifteen (15) days after completion of tests but if the tests are not witnessed by the Purchaser /Inspector, the certificate shall be issued within fifteen (15) days of receipt of the Contractor's Test certificate by the Engineer/Inspector. Failure of the Purchaser /Inspector to issue such a certificate shall not prevent the Contractor from proceeding with the Works. The completion of these tests or the issue of the certificate shall not bind the Purchaser to accept the equipment should, it, on further tests after erection, be found not to comply with the Contract. The equipment shall be dispatched to site only after approval of test reports and issuance of CIP by the Purchaser.

<b>Project</b>	<b>765/400KV (UPPTCL) NEW SUBSATATION AT AGRA</b>	<b>TB-376-522-01 Rev 00</b>	
<b>System</b>	<b>FIRE FIGHTING SYSTEM</b>		
<b>Owner</b>	<b>UPPTCL</b>		
<b>Customer</b>	<b>POWER GRID CORPORATION OF INDIA LTD</b>		
<b>Purchaser</b>	<b>BHEL (TRANSMISSION BUSINESS GROUP)</b>		

9.8 In all cases where the Contract provides for tests whether at the premises or at the works of the Contractor or of any Sub-Contractor, the Contractor except where otherwise specified shall provide free of charge such items as labour, materials, electricity, fuel, water, stores, apparatus and instruments as may be reasonably demanded by the Purchaser /Inspector or his authorised representative to carry out effectively such tests of the equipment in accordance with the Contract and shall give facilities to the Purchaser /Inspector or to his authorised representative to accomplish testing.

9.9 The inspection by Purchaser and issue of Inspection Certificate thereon shall in no way limit the liabilities and responsibilities of the Contractor in respect of the agreed quality assurance programme forming a part of the Contract.

9.10 The Purchaser will have the right of having at his own expenses any other test(s) of reasonable nature carried out at Contractor's premises or at site or in any other place in addition of aforesaid type and routine tests, to satisfy that the material comply with the specification.

9.11 The Purchaser reserves the right for getting any field tests not specified in respective sections of the technical specification conducted on the completely assembled equipment at site. The testing equipments for these tests shall be provided by the Purchaser.

## **10.0 TESTS**

### **10.1 Pre-commissioning Tests**

On completion of erection of the equipment and before charging, each item of the equipment shall be thoroughly cleaned and then inspected jointly by the Purchaser and the Contractor for correctness and completeness of installation and acceptability for charging, leading to initial pre-commissioning tests at Site. The list of pre-commissioning tests to be performed are given in respective chapters and shall be included in the Contractor's quality assurance programme.

### **10.2 Commissioning Tests**

10.2.1 The available instrumentation and control equipment will to be used during such tests and the Purchaser will calibrate, all such measuring equipment and devices as far as practicable.

10.2.2 Any special equipment, tools and tackles required for the successful completion of the Commissioning Tests shall be provided by the Contractor, free of cost.

10.2.3 The specific tests requirement on equipment have been brought out in the respective chapters of the technical specification.

10.3 The Contractor shall be responsible for obtaining statutory clearances from the concerned authorities for commissioning the equipment and the switchyard. However necessary fee shall be reimbursed by POWERGRID on production of requisite documents.

## **11.0 PACKAGING & PROTECTION**

11.1 All the equipments shall be suitably protected, coated, covered or boxed and crated to prevent damage or deterioration during transit, handling and

<b>Project</b>	<b>765/400KV (UPPTCL) NEW SUBSATATION AT AGRA</b>	<b>TB-376-522-01 Rev 00</b>	
<b>System</b>	<b>FIRE FIGHTING SYSTEM</b>		
<b>Owner</b>	<b>UPPTCL</b>		
<b>Customer</b>	<b>POWER GRID CORPORATION OF INDIA LTD</b>		
<b>Purchaser</b>	<b>BHEL (TRANSMISSION BUSINESS GROUP)</b>		

storage at Site till the time of erection. On request of the Purchaser, the Contractor shall also submit packing details/associated drawing for any equipment/material under his scope of supply, to facilitate the Purchaser to repack any equipment/material at a later date, in case the need arises. While packing all the materials, the limitation from the point of view of availability of Railway wagon sizes in India should be taken into account. The Contractor shall be responsible for any loss or damage during transportation, handling and storage due to improper packing. Any demurrage, wharfage and other such charges claimed by the transporters, railways etc. shall be to the account of the Contractor. Purchaser takes no responsibility of the availability of the wagons.

11.2 All coated surfaces shall be protected against abrasion, impact, discolouration and any other damages. All exposed threaded portions shall be suitably protected with either a metallic or a non-metallic protecting device. All ends of all valves and pipings and conduit equipment connections shall be properly sealed with suitable devices to protect them from damage.

## **12.0 FINISHING OF METAL SURFACES**

12.1 All metal surfaces shall be subjected to treatment for anti-corrosion protection. All ferrous surfaces for external use unless otherwise stated elsewhere in the specification or specifically agreed, shall be hot-dip galvanized after fabrication. High tensile steel nuts & bolts and spring washers shall be electro galvanized to service condition 4. All steel conductors including those used for earthing/grounding (above ground level) shall also be galvanized according to IS:2629.

### **12.2 HOT DIP GALVANISING**

12.2.1 The minimum weight of the zinc coating shall be 610 gm/sq.m and minimum average thickness of coating shall be 86 microns for all items having thickness 6mm and above. For items lower than 6mm thickness requirement of coating thickness shall be as per relevant ASTM. For surface which shall be embedded in concrete, the zinc coating shall be 610 gm/sq. m minimum.

12.2.2 The galvanized surfaces shall consist of a continuous and uniform thick coating of zinc, firmly adhering to the surface of steel. The finished surface shall be clean and smooth and shall be free from defects like discoloured patches, bare spots, unevenness of coating, spelter which is loosely attached to the steel globules, spiky deposits, blistered surface, flaking or peeling off, etc. The presence of any of these defects noticed on visual or microscopic inspection shall render the material liable to rejection.

12.2.3 After galvanizing. no drilling or welding shall be performed on the galvanized parts of the equipment excepting that nuts may be threaded after galvanizing. Sodium dichromate treatment shall be provided to avoid formation of white rust after hot dip galvanization.

12.2.4 The galvanized steel shall be subjected to six one minute dips in copper sulphate solution as per IS-2633.

12.2.5 Sharp edges with radii less than 2.5 mm shall be able to withstand

<b>Project</b>	<b>765/400KV (UPPTCL) NEW SUBSATATION AT AGRA</b>	<b>TB-376-522-01 Rev 00</b>	
<b>System</b>	<b>FIRE FIGHTING SYSTEM</b>		
<b>Owner</b>	<b>UPPTCL</b>		
<b>Customer</b>	<b>POWER GRID CORPORATION OF INDIA LTD</b>		
<b>Purchaser</b>	<b>BHEL (TRANSMISSION BUSINESS GROUP)</b>		

four immersions of the Standard Preece test. All other coatings shall withstand six immersions. The following galvanizing tests should essentially be performed as per relevant Indian Standards.

- Coating thickness
- Uniformity of zinc
- Adhesion test
- Mass of zinc coating

12.2.6 Galvanised material must be transported properly to ensure that galvanised surfaces are not damaged during transit. Application of zinc rich paint at site shall not be allowed.

### 12.3 PAINTING

12.3.1 All sheet steel work shall be degreased, pickled, phosphated in accordance with the IS-6005 "Code of practice for phosphating iron and sheet". All surfaces, which will not be easily accessible after shop assembly, shall beforehand be treated and protected for the life of the equipment. The surfaces, which are to be finished painted after installation or require corrosion protection until installation, shall be shop painted with at least two coats of primer. Oil, grease, dirt and swaf shall be thoroughly removed by emulsion cleaning. Rust and scale shall be removed by pickling with dilute acid followed by washing with running water, rinsing with slightly alkaline hot water and drying.

12.3.2 After phosphating, thorough rinsing shall be carried out with clean water followed by final rinsing with dilute dichromate solution and oven drying. The phosphate coating shall be sealed with application of two coats of ready mixed, stoving type zinc chromate primer. The first coat may be "flash dried" while the second coat shall be stoved.

12.3.3 After application of the primer, two coats of finishing synthetic enamel paint shall be applied, each coat followed by stoving. The second finishing coat shall be applied after inspection of first coat of painting.

12.3.4 The exterior and interior colour of the paint in case of new substations shall preferably be RAL 7032 for all equipment, marshalling boxes, junction boxes, control cabinets, panels etc. unless specifically mentioned under respective sections of the equipments. Glossy white colour inside the equipments /boards/panels/junction boxes is also acceptable. The exterior colour for panels shall bematching with the existing panels in case of extension of a substation. Each coatof primer and finishing paint shall be of slightly different shade to enable inspection of the painting. A small quantity of finishing paint shall be supplied for minor touching up required at site after installation of the equipments.

12.3.5 In case the Bidder proposes to follow his own standard surface finish and protection procedures or any other established painting procedures, like electrostatic painting etc., the procedure shall be submitted alongwith the Bids for Purchaser's review & approval.

<b>Project</b>	<b>765/400KV (UPPTCL) NEW SUBSATATION AT AGRA</b>	<b>TB-376-522-01 Rev 00</b>	
<b>System</b>	<b>FIRE FIGHTING SYSTEM</b>		
<b>Owner</b>	<b>UPPTCL</b>		
<b>Customer</b>	<b>POWER GRID CORPORATION OF INDIA LTD</b>		
<b>Purchaser</b>	<b>BHEL (TRANSMISSION BUSINESS GROUP)</b>		

12.3.6 The colour scheme as given below shall be followed for Fire Protection systems

S.No.	PIPE LINE	Base colour	Band colour
<b>Fire Protection System</b>			
1	Hydrant and Emulsifier system pipeline	FIRE RED	-
2	Emulsifier system detection line – water	FIRE RED	Sea Green
3	Emulsifier system detection line – Air	FIRE RED	Sky Blue
4	Pylon support pipes	FIRE RED	

12.3.7 For aluminium casted surfaces, the surface shall be with smooth finish. Further, in case of aluminium enclosures the surface shall be coated with powder (coating thickness of 60 microns) after surface preparation for painting.

### 13.0 HANDLING, STORING AND INSTALLATION

- 13.1 In accordance with the specific installation instructions as shown on manufacturer's drawings or as directed by the Purchaser or his representative, the Contractor shall unload, store, erect, install, wire, test and place into commercial use all the equipment included in the contract. Equipment shall be installed in a neat, workmanlike manner so that it is level, plumb, square and properly aligned and oriented. Commercial use of switchyard equipment means completion of all site tests specified and energisation at rated voltage.
- 13.2 Contractor may engage manufacturer's Engineers to supervise the unloading, transportation to site, storing, testing and commissioning of the various equipment being procured by them separately. Contractor shall unload, transport, store, erect, test and commission the equipment as per instructions of the manufacturer's supervisory Engineer(s) and shall extend full cooperation to them.
- 13.3 The contractor shall have to ensure that the hard and flat indoor and outdoor storage areas are in place prior to commencement of delivery of material at site. Contractor shall also ensure availability of proper unloading and material handling equipment like cranes etc. and polyester/nylon ropes of suitable capacity to avoid damage during unloading and handling of material at site. All indoor equipments shall be stored indoors. Outdoor equipment may be stored outdoors but on a hard and flat raised area properly covered with waterproof and dustproof covers to protect them from water seepage and moisture ingress. However, all associated control panels, marshalling boxes operating boxes etc. of outdoor equipments are to be stored indoors only. Storage of equipment on top of another one is not permitted if the wooden packing is used. Material opened for joint inspection shall be repacked properly as per manufacturer's recommendations. During storage of material regular periodic monitoring of important parameters like oil level / leakage, SF6 /

<b>Project</b>	<b>765/400KV (UPPTCL) NEW SUBSATATION AT AGRA</b>	<b>TB-376-522-01 Rev 00</b>	
<b>System</b>	<b>FIRE FIGHTING SYSTEM</b>		
<b>Owner</b>	<b>UPPTCL</b>		
<b>Customer</b>	<b>POWER GRID CORPORATION OF INDIA LTD</b>		
<b>Purchaser</b>	<b>BHEL (TRANSMISSION BUSINESS GROUP)</b>		

Nitrogen pressure etc. shall be ensured by the contractor.

- 13.4 In case of any doubt/misunderstanding as to the correct interpretation of manufacturer's drawings or instructions, necessary clarifications shall be obtained from the Purchaser. Contractor shall be held responsible for any damage to the equipment consequent to not following manufacturer's drawings/instructions correctly.
- 13.5 Where assemblies are supplied in more than one section, Contractor shall make all necessary mechanical and electrical connections between sections including the connection between buses. Contractor shall also do necessary adjustments/alignments necessary for proper operation of circuit breakers, isolators and their operating mechanisms. All components shall be protected against damage during unloading, transportation, storage, installation, testing and commissioning. Any equipment damaged due to negligence or carelessness or otherwise shall be replaced by the Contractor at his own expense.
- 13.6 Supplier shall be responsible for examining all the shipment and notify the Purchaser immediately of any damage, shortage, discrepancy etc. for the purpose of Purchaser's information only. The Contractor shall submit to the Purchaser every week a report detailing all the receipts during the weeks. However, the Contractor shall be solely responsible for any shortages or damages in transit, handling and/or in storage and erection of the equipment at Site Any demurrage, wharfage and other such charges claimed by the transporters, railways etc. shall be to the account of the Contractor.
- 13.7 The supplier shall be fully responsible for the equipment/material until the same is handed over to the Purchaser in an operating condition after commissioning. Contractor shall be responsible for the maintenance of the equipment/material while in storage as well as after erection until taken over by Purchaser, as well as protection of the same against theft, element of nature, corrosion, damages etc.
- 13.8 Where material / equipment is unloaded by Purchaser before the Contractor arrives at site or even when he is at site, Purchaser by right can hand over the same to Contractor and there upon it will be the responsibility of Contractor to store the material in an orderly and proper manner.
- 13.9 The Contractor shall be responsible for making suitable indoor storage facilities, to store all equipment which requires indoor storage.
- 13.10 The words 'erection' and 'installation' used in the specification are synonymous.
- 13.11 Exposed live parts shall be placed high enough above ground to meet the requirements of electrical and other statutory safety codes.
- 13.12 Equipment Bases
- A cast iron or welded steel base plate shall be provided for all rotating equipment which is to be installed on a concrete base unless otherwise

<b>Project</b>	<b>765/400KV (UPPTCL) NEW SUBSATATION AT AGRA</b>	<b>TB-376-522-01 Rev 00</b>	
<b>System</b>	<b>FIRE FIGHTING SYSTEM</b>		
<b>Owner</b>	<b>UPPTCL</b>		
<b>Customer</b>	<b>POWER GRID CORPORATION OF INDIA LTD</b>		
<b>Purchaser</b>	<b>BHEL (TRANSMISSION BUSINESS GROUP)</b>		

agreed to by the Purchaser. Each base plate shall support the unit and its drive assembly, shall be of a neat design with pads for anchoring the units, shall have a raised lip all around, and shall have threaded drain connections.

#### 14.0 TOOLS AND TACKLES

The Contractor shall supply with the equipment one complete set of all special tools and tackles for the erection, assembly, dis-assembly and maintenance of the equipment. However, these tools and tackles shall be separately, packed and brought on to Site.

#### 15.0 AUXILIARY SUPPLY

- 15.1 The sub-station auxiliary supply is normally met through a system indicated under section "Electrical & Mechanical Auxiliaries" having the following parameters. The auxiliary power for station supply, including the equipment drive, cooling system of any equipment, air-conditioning, lighting etc shall be designed for the specified Parameters as under. The DC supply for the instrumentation and PLCC system shall also conform the parameters as indicated in the following.

Normal Voltage	Variation in Voltage	Frequency in HZ	Phase/Wire	Neutral connection
415V	± 10%	50 ± 5%	3/4 Wire	Solidly Earthed.
240V	± 10%	50 ± 5%	1/2 Wire	Solidly Earthed.
220V	190V to 240V	DC	-	Isolated 2 wire System
48V	-	DC	-	2 wire system (+) earthed

Combined variation of voltage and frequency shall be limited to ± 10%.

#### 16.0 SUPPORT STRUCTURE (If in the scope of supplier)

- 16.1 The equipment support structures shall be suitable for equipment connections at the first level i.e 14.0 meter, 8.0 meter and 5.9 meter from plinth level for 765 kV, 420 kV and 245 kV substations respectively. All equipment support structures shall be supplied alongwith brackets, angles, stools etc. for attaching the operating mechanism, control cabinets & marshalling box (wherever applicable) etc.
- 16.2 Support structure shall meet the following mandatory requirements:
- 16.2.1 The minimum vertical distance from the bottom of the lowest porcelain part of the bushing, porcelain enclosures or supporting insulators to the bottom of the equipment base, where it rests on the foundation pad shall be 2.55 metres.

#### 17.0 CLAMPS AND CONNECTORS INCLUDING TERMINAL CONNECTORS

- 17.1 All power clamps and connectors shall conform to IS:5561 & NEMA CC1 and shall be made of materials listed below :
- a) For connecting ACSR conductors
- Aluminum alloy casting, conforming to designation A6 of IS:617 and all test shall

<b>Project</b>	<b>765/400KV (UPPTCL) NEW SUBSATATION AT AGRA</b>	<b>TB-376-522-01 Rev 00</b>	
<b>System</b>	<b>FIRE FIGHTING SYSTEM</b>		
<b>Owner</b>	<b>UPPTCL</b>		
<b>Customer</b>	<b>POWER GRID CORPORATION OF INDIA LTD</b>		
<b>Purchaser</b>	<b>BHEL (TRANSMISSION BUSINESS GROUP)</b>		

- conform to IS:617
- b) For connecting equipment terminals made of copper with ACSR conductors Bimetallic connectors made from aluminum alloy casting, conforming to designation A6 of IS:617 with 2mm thick bimetallic liner and all test shall conform to IS:617
- c) For connecting G.I Galvanised mild steel shield
- d) i) Bolts, nuts & Plain, washers i) Electrogalvanised for sizes below M12, for others hot dip galvanised.
- ii) Spring washers items 'a' to 'c' ii) Electro-galvanised mild for steel suitable for atleast service condition-3 as per IS:1573
- 17.2 Necessary clamps and connectors shall be supplied for all equipment and connections. The requirement regarding external corona and RIV as specified for any equipment shall include its terminal fittings. If corona rings are required to meet these requirements they shall be considered as part of that equipment and included in the scope of work.
- 17.3 Where copper to aluminum connections are required, bi-metallic clamps shall be used, which shall be properly designed to ensure that any deterioration of the connection is kept to a minimum and restricted to parts which are not current carrying or subjected to stress.
- 17.4 Low voltage connectors, grounding connectors and accessories for grounding allequipment as specified in each particular case, are also included in the scope of Work.
- 17.5 No current carrying part of any clamp shall be less than 10 mm thick. All ferrous parts shall be hot dip galvanised. Copper alloy liner of minimum 2 mm thickness shall be cast integral with aluminum body or 2 mm thick bi-metallic strips shall be provided for Bi-metallic clamps.
- 17.6 All casting shall be free from blow holes, surface blisters, cracks and cavities. All sharp edges and corners shall be blurred and rounded off.
- 17.7 Flexible connectors, braids or laminated straps made for the terminal clamps for bus posts shall be suitable for both expansion or through (fixed/sliding) type connection of 4" IPS AL. tube as required. In both the cases the clamp height (topof the mounting pad to centre line of the tube) should be same.
- 17.8 Clamp shall be designed to carry the same current as the conductor and the temperature rise shall be equal or less than that of the conductor at the specified ambient temperature. The rated current for which the clamp/connector is designed with respect to the specified reference ambient temperature, shall also be indelibly marked on each component of the clamp/connector, except on the hardware.
- 17.9 All current carrying parts shall be designed and manufactured to have

<b>Project</b>	<b>765/400KV (UPPTCL) NEW SUBSATATION AT AGRA</b>	<b>TB-376-522-01 Rev 00</b>	
<b>System</b>	<b>FIRE FIGHTING SYSTEM</b>		
<b>Owner</b>	<b>UPPTCL</b>		
<b>Customer</b>	<b>POWER GRID CORPORATION OF INDIA LTD</b>		
<b>Purchaser</b>	<b>BHEL (TRANSMISSION BUSINESS GROUP)</b>		

minimum contact resistance.

17.10 Clamps and connectors shall be designed to be corona controlled.

#### 17.11 Tests

17.11.1 Clamps and connectors should be type tested as per IS:5561 and shall also be subjected to routine tests as per IS:5561. Following type test reports shall be submitted for approval as per clause 9.2 above except for sl. no.(ii) & (iii) for which type test once conducted shall be applicable (i.e. the requirement of test conducted within last ten years shall not be applicable).

- i) Temperature rise test (maximum temperature rise allowed is 35°C over 50°C ambient)
- ii) Short time current test
- iii) Corona (dry) and RIV (dry) test (for 220 KV and above voltage level clamps)
- iv) Resistance test and tensile test

#### 18.0 CONTROL CABINETS, JUNCTION BOXES, TERMINAL BOXES & MARSHALLING BOXES FOR OUTDOOR EQUIPMENT

- 18.1 All types of boxes, cabinets etc. shall generally conform to & be tested in accordance with IS-5039/IS-8623, IEC-60439, as applicable, and the clauses given below:
- 18.2 Control cabinets, junction boxes, Marshalling boxes & terminal boxes shall be made of sheet steel or aluminum enclosure and shall be dust, water and vermin proof. Sheet steel used shall be atleast 2.0 mm thick cold rolled or 2.5 mm hot rolled or alternately 1.6 mm thick stainless steel can also be used. The box shall be properly braced to prevent wobbling. There shall be sufficient reinforcement to provide level surfaces, resistance to vibrations and rigidity during transportation and installation. In case of aluminum enclosed box the thickness of aluminum shall be such that it provides adequate rigidity and long life as comparable with sheet steel of specified thickness.
- 18.3 A canopy and sealing arrangements for operating rods shall be provided inmarshalling boxes / Control cabinets to prevent ingress of rain water.
- 18.4 Cabinet/boxes shall be provided with double hinged doors with padlocking arrangements. The distance between two hinges shall be adequate to ensure uniform sealing pressure against atmosphere. The quality of the gasket shall be such that it does not get damaged/cracked during the operation of the equipment.
- 18.5 All doors, removable covers and plates shall be gasketed all around with suitably profiled EPDM/Neoprene gaskets. The gasket shall be tested in accordance with approved quality plan, IS:11149 and IS:3400. Ventilating Louvers, if provided, shall have screen and filters. The screen shall be fine wire mesh made of brass.
- 18.6 All boxes/cabinets shall be designed for the entry of cables from bottom by meanof weather proof and dust-proof connections. Boxes and cabinets shall be designed with generous clearances to avoid interference between

<b>Project</b>	<b>765/400KV (UPPTCL) NEW SUBSATATION AT AGRA</b>	<b>TB-376-522-01 Rev 00</b>	
<b>System</b>	<b>FIRE FIGHTING SYSTEM</b>		
<b>Owner</b>	<b>UPPTCL</b>		
<b>Customer</b>	<b>POWER GRID CORPORATION OF INDIA LTD</b>		
<b>Purchaser</b>	<b>BHEL (TRANSMISSION BUSINESS GROUP)</b>		

the wiring entering from below and any terminal blocks or accessories mounted within the box or cabinet. Suitable cable gland plate above the base of the marshalling kiosk/box shall be provided for this purpose along with the proper blanking plates. Necessary number of cable glands shall be supplied and fitted on this gland plate. Gland plate shall have provision for some future glands to be provided later, if required. The Nickel plated glands shall be dust proof, screw on & double compression type and made of brass. The gland shall have provision for securing armour of the cable separately and shall be provided with earthing tag. The glands shall conform to BS:6121.

- 18.7 A 240V, single phase, 50 Hz, 15 amp AC plug and socket shall be provided in the cabinet with ON-OFF switch for connection of hand lamps. Plug and socket shall be of industrial grade.
- 18.8 For illumination, a fluorescent tube or CFL of approximately 9 to 15 watts shall be provided. The switching of the fittings shall be controlled by the door switch. .  
For junction boxes of smaller sizes such as lighting junction box, manual operated earth switch mechanism box etc., plug socket, heater and illumination is not required to be provided.
- 18.9 All control switches shall be of MCB/rotary switch type and Toggle/piano switches shall not be accepted.
- 18.10 Positive earthing of the cabinet shall be ensured by providing two separate earthing pads. The earth wire shall be terminated on to the earthing pad and secured by the use of self etching washer. Earthing of hinged door shall be done by using a separate earth wire.
- 18.11 The bay marshalling kiosks shall be provided with danger plate and a diagram showing the numbering/connection/feruling by pasting the same on the inside of the door.
- 18.12 a) The following routine tests alongwith the routine tests as per IS:5039 shall also be conducted:  
i) Check for wiring  
ii) Visual and dimension check  
b) The enclosure of bay marshalling kiosk, junction box, terminal box shall conform to IP-55 as per IS:13947 including application of, 2.5 KV rms for 1 (one) minute, insulation resistance and functional test after IP-55 test.
- 19.0 Deleted.
- 20.0 TERMINAL BLOCKS AND WIRING**
- 20.1 Control and instrument leads from the switchboards or from other equipment will be brought to terminal boxes or control cabinets in conduits. All interphase and external connections to equipment or to control cubicles will be made through terminal blocks.
- 20.2 Terminal blocks shall be 650V grade and have continuous rating to carry the maximum expected current on the terminals and non breakable type. These shall be of moulded piece, complete with insulated barriers, stud type terminals, washers, nuts and lock nuts. Screw clamp, overall insulated, insertion type, rail mounted terminals can be used in place of stud type terminals. But preferably the terminal blocks shall be non-disconnecting stud

<b>Project</b>	<b>765/400KV (UPPTCL) NEW SUBSATATION AT AGRA</b>	<b>TB-376-522-01 Rev 00</b>	
<b>System</b>	<b>FIRE FIGHTING SYSTEM</b>		
<b>Owner</b>	<b>UPPTCL</b>		
<b>Customer</b>	<b>POWER GRID CORPORATION OF INDIA LTD</b>		
<b>Purchaser</b>	<b>BHEL (TRANSMISSION BUSINESS GROUP)</b>		

type of Elmex or Phoenix or Wago or equivalent make.

- 20.3 Terminal blocks for current transformer and voltage transformer secondary leads shall be provided with test links and isolating facilities. The current transformer secondary leads shall also be provided with short circuiting and earthing facilities.
- 20.4 The terminal shall be such that maximum contact area is achieved when a cable is terminated. The terminal shall have a locking characteristic to prevent cable from escaping from the terminal clamp unless it is done intentionally.
- 20.5 The conducting part in contact with cable shall preferably be tinned or silver plated however Nickel plated copper or zinc plated steel shall also be acceptable.
- 20.6 The terminal blocks shall be of extensible design.
- 20.7 The terminal blocks shall have locking arrangement to prevent its escape from the mounting rails.
- 20.8 The terminal blocks shall be fully enclosed with removable covers of transparent, non-deteriorating type plastic material. Insulating barriers shall be provided between the terminal blocks. These barriers shall not hinder the operator from carrying out the wiring without removing the barriers.
- 20.9 Unless otherwise specified terminal blocks shall be suitable for connecting the following conductors on each side.
- |    |                                    |  |
|----|------------------------------------|--|
| a) | All circuits except CT/PT circuits | Minimum of two of 2.5 sq mm copper flexible. |
| b) | All CT/PT circuits                 | Minimum of 4 nos. of 2.5 sq copper flexible. |
- 20.10 The arrangements shall be in such a manner so that it is possible to safely connect or disconnect terminals on live circuits and replace fuse links when the cabinet is live.
- 20.11 Atleast 20 % spare terminals shall be provided on each panel/cubicle/box and these spare terminals shall be uniformly distributed on all terminals rows.
- 20.12 There shall be a minimum clearance of 250 mm between the First/bottom row of terminal block and the associated cable gland plate for outdoor ground mounted marshalling box and the clearance between two rows of terminal blocks shall be a minimum of 150 mm.
- 20.13 The supplier shall furnish all wire, conduits and terminals for the necessary interphase electrical connections (where applicable) as well as between phases and common terminal boxes or control cabinets. For equipments rated for 400 kV and above the wiring required in these items shall be run in metallic ducts or shielded cables in order to avoid surge overvoltages either transferred through the equipment or due to transients induced from the EHV circuits.
- 20.14 All input and output terminals of each control cubicle shall be tested for surgewithstand capability in accordance with the relevant IEC Publications, in both longitudinal and transverse modes. The Contractor shall also provide all necessary filtering, surge protection, interface relays and any other measures necessary to achieve an impulse withstand level at the cable

<b>Project</b>	<b>765/400KV (UPPTCL) NEW SUBSATATION AT AGRA</b>	<b>TB-376-522-01 Rev 00</b>	
<b>System</b>	<b>FIRE FIGHTING SYSTEM</b>		
<b>Owner</b>	<b>UPPTCL</b>		
<b>Customer</b>	<b>POWER GRID CORPORATION OF INDIA LTD</b>		
<b>Purchaser</b>	<b>BHEL (TRANSMISSION BUSINESS GROUP)</b>		

interfaces of the equipment.

## 21.0 LAMPS & SOCKETS

### 21.1 Sockets

All sockets (convenience outlets) shall be suitable to accept both 5 Amp & 15 Amp pin round Standard Indian plugs. They shall be switched sockets with shutters.

### 21.2 Hand Lamp:

A 240 Volts, single Phase, 50 Hz AC plug point shall be provided in the interior of each cubicle with ON-OFF Switch for connection of hand lamps.

### 21.3 Switches and Fuses:

21.3.1 Each panel shall be provided with necessary arrangements for receiving, distributing, isolating and fusing of DC and AC supplies for various control, signalling, lighting and space heater circuits. The incoming and sub-circuits shall be separately provided with miniature circuit breaker / switchfuse units. Selection of the main and Sub-circuit fuse ratings shall be such as to ensure selective clearance of sub-circuit faults. Potential circuits for relaying and metering shall be protected by HRC fuses.

21.3.2 All fuses shall be of HRC cartridge type conforming to IS:9228 mounted on plug-in type fuse bases. Miniature circuit breakers with thermal protection and alarm contacts will also be accepted. All accessible live connection to fuse bases shall be adequately shrouded. Fuses shall have operation indicators for indicating blown fuse condition. Fuse carrier base shall have imprints of the fuse rating and voltage.

## 22.0 Bushings, Hollow Column Insulators, Support Insulators:

22.1 Bushings shall be manufactured and tested in accordance with IS:2099 & IEC- 60137 while hollow column insulators shall be manufactured and tested in accordance with IEC-62155/IS:5621. The support insulators shall be manufactured and tested as per IS:2544/IEC-60168 and IEC-60273. The insulators shall also conform to IEC-60815 as applicable. The bidder may also offer composite hollow insulators, conforming to IEC-61462.

22.2 Support insulators, bushings and hollow column insulators shall be manufactured from high quality porcelain. Porcelain used shall be homogeneous, free from laminations, cavities and other flaws or imperfections that might affect the mechanical or dielectric quality and shall be thoroughly vitrified tough and impervious to moisture.

22.3 Glazing of the porcelain shall be uniform brown in colour, free from blisters, burrs and similar other defects.

22.4 Support insulators/bushings/hollow column insulators shall be designed to have ample insulation, mechanical strength and rigidity for the conditions under which they will be used.

22.5 When operating at normal rated voltage there shall be no electric discharge between the conductors and bushing which would cause corrosion or injury to conductors, insulators or supports by the formation of substances produced by chemical action. No radio interference shall be

<b>Project</b>	<b>765/400KV (UPPTCL) NEW SUBSATATION AT AGRA</b>	<b>TB-376-522-01 Rev 00</b>	
<b>System</b>	<b>FIRE FIGHTING SYSTEM</b>		
<b>Owner</b>	<b>UPPTCL</b>		
<b>Customer</b>	<b>POWER GRID CORPORATION OF INDIA LTD</b>		
<b>Purchaser</b>	<b>BHEL (TRANSMISSION BUSINESS GROUP)</b>		

caused by the insulators/bushings when operating at the normal rated voltage.

22.6 Bushing porcelain shall be robust and capable of withstanding the internal pressures likely to occur in service. The design and location of clamps and the shape and the strength of the porcelain flange securing the bushing to the tank shall be such that there is no risk of fracture. All portions of the assembled porcelain enclosures and supports other than gaskets, which may in any way be exposed to the atmosphere shall be composed of completely non hygroscopic material such as metal or glazed porcelain.

22.7 All iron parts shall be hot dip galvanised and all joints shall be air tight. Surface of joints shall be trued up porcelain parts by grinding and metal parts by machining. Insulator/bushing design shall be such as to ensure a uniform compressive pressure on the joints.

#### 22.8 Tests

In bushing, hollow column insulators and support insulators shall conform to type tests and shall be subjected to routine tests in accordance with IS: 2099 & IS:2544 & IS : 5621.

#### 23.0 MOTORS

Motors shall be "Squirrel Cage" three phase induction motors of sufficient size capable of satisfactory operation for the application and duty as required for the driven equipment and shall be subjected to routine tests as per applicable standards. The motors shall be of approved make.

#### 23.1 Enclosures

- Motors to be installed outdoor without enclosure shall have hose proof enclosure equivalent to IP-55 as per IS: 4691. For motors to be installed indoor i.e. inside a box, the motor enclosure, shall be dust proof equivalent to IP-44 as per IS: 4691.
- Two independent earthing points shall be provided on opposite sides of the motor for bolted connection of earthing conductor.
- Motors shall have drain plugs so located that they will drain water resulting from condensation or other causes from all pockets in the motor casing.
- Motors weighing more than 25 Kg. shall be provided with eyebolts, lugs or other means to facilitate lifting.

#### 23.2 Operational Features

- Continuous motor rating (name plate rating) shall be at least ten (10) percent above the maximum load demand of the driven equipment at design duty point and the motor shall not be over loaded at any operating point of driven equipment that will rise in service.
- Motor shall be capable at giving rated output without reduction in the expected life span when operated continuously in the system having the particulars as given in Clause 15.0 of this Section.

#### 23.3 Starting Requirements:

- All induction motors shall be suitable for full voltage direct-on-line

<b>Project</b>	<b>765/400KV (UPPTCL) NEW SUBSATATION AT AGRA</b>	<b>TB-376-522-01 Rev 00</b>	
<b>System</b>	<b>FIRE FIGHTING SYSTEM</b>		
<b>Owner</b>	<b>UPPTCL</b>		
<b>Customer</b>	<b>POWER GRID CORPORATION OF INDIA LTD</b>		
<b>Purchaser</b>	<b>BHEL (TRANSMISSION BUSINESS GROUP)</b>		

starting. These shall be capable of starting and accelerating to the rated speed alongwith the driven equipment without exceeding the acceptable winding temperature even when the supply voltage drops down to 80% of the rated voltage.

- b) Motors shall be capable of withstanding the electrodynamic stresses and heating imposed if it is started at a voltage of 110% of the rated value.
- c) The locked rotor current shall not exceed six (6) times the rated full load current for all motors, subject to tolerance as given in IS:325.
- d) Motors when started with the driven equipment imposing full starting torque under the supply voltage conditions specified under Clause 15.0 shall be capable of withstanding atleast two successive starts from cold condition at room temperature and one start from hot condition without injurious heating of winding. The motors shall also be suitable for three equally spread starts per hour under the above referred supply condition.
- e) The locked rotor withstand time under hot condition at 110% of rated voltage shall be more than starting time with the driven equipment of minimum permissible voltage by at least two seconds or 15% of the accelerating time whichever is greater. In case it is not possible to meet the above requirement, the Bidder shall offer centrifugal type speed switch mounted on the motor shaft which shall remain closed for speed lower than 20% and open for speeds above 20% of the rated speed. The speed switch shall be capable of withstanding 120% of the rated speed in either direction of rotation.

#### **23.4 Running Requirements:**

- a) The maximum permissible temperature rise over the ambient temperature of 50 degree C shall be within the limits specified in IS:325 (for 3 - phase induction motors) after adjustment due to increased ambient temperature specified.
- b) The double amplitude of motor vibration shall be within the limits specified in IS: 4729. Vibration shall also be within the limits specified by the relevant standard for the driven equipment when measured at the motor bearings.
- c) All the induction motors shall be capable of running at 80% of rated voltage for a period of 5 minutes with rated load commencing from hot condition.

#### **23.5 TESTING AND COMMISSIONING**

An indicative list of tests is given below. Contractor shall perform any additional test based on specialities of the items as per the field Q.P./Instructions of the equipment Contractor or Purchaser without any extra cost to the Purchaser. The Contractor shall arrange all instruments required for conducting these tests alongwith calibration certificates and shall furnish the list of instruments to the Purchaser for approval.

- (a) Insulation resistance.
- (b) Phase sequence and proper direction of rotation.
- (c) Any motor operating incorrectly shall be checked to determine the cause.

<b>Project</b>	<b>765/400KV (UPPTCL) NEW SUBSATATION AT AGRA</b>	<b>TB-376-522-01 Rev 00</b>	
<b>System</b>	<b>FIRE FIGHTING SYSTEM</b>		
<b>Owner</b>	<b>UPPTCL</b>		
<b>Customer</b>	<b>POWER GRID CORPORATION OF INDIA LTD</b>		
<b>Purchaser</b>	<b>BHEL (TRANSMISSION BUSINESS GROUP)</b>		

**SECTION 4**  
**GUARANTEED TECHNICAL PARTICULARS**

Powergrid 's standard GTPs for the fire fighting items are attached in section-2 for reference. However final GTP shall be submitted and approved by customer during detailed engineering.

<b>Project</b>	<b>765/400KV (UPPTCL) NEW SUBSATATION AT AGRA</b>	<b>TB-376-522-01 Rev 00</b>	
<b>System</b>	<b>FIRE FIGHTING SYSTEM</b>		
<b>Owner</b>	<b>UPPTCL</b>		
<b>Customer</b>	<b>POWER GRID CORPORATION OF INDIA LTD</b>		
<b>Purchaser</b>	<b>BHEL (TRANSMISSION BUSINESS GROUP)</b>		

**SECTION- 5**  
**ENCLOSURES TO SPECIFICATION**

**SCHEDULES TO BE FILLED UP BY THE BIDDER**

- Schedule 1    **Schedule of Deviations**
  - Schedule 2    **Details of contact persons (technical & commercial)**
  - Schedule 3    **Enclosures to Specification**
- a) List of Powergrid approved makes (APPENDIX-V of section-2)**
  - b) Drawings**

<b>Project</b>	<b>765/400KV (UPPTCL) NEW SUBSATATION AT AGRA</b>	<b>TB-376-522-01 Rev 00</b>	
<b>System</b>	<b>FIRE FIGHTING SYSTEM</b>		
<b>Owner</b>	<b>UPPTCL</b>		
<b>Customer</b>	<b>POWER GRID CORPORATION OF INDIA LTD</b>		
<b>Purchaser</b>	<b>BHEL (TRANSMISSION BUSINESS GROUP)</b>		

## SCHEDULE-1

### SCHEDULE OF TECHNICAL DEVIATION

The following are the deviations / variations / exceptions from the specification:

Section	Clause No./ Page No.	Statement of deviation/ Variations/Exceptions
---------	-------------------------	--

- 1) In case, this schedule is not submitted, it will be presumed that the equipment /material to be supplied under this contract is deemed to be in compliance with the specification.
- 2) If there is NIL deviation, even then the format to be filled as **NIL DEVIATION**
- 3) Continuation sheets of like size and format may be used as per the Bidder's Requirement and shall be annexed to this schedule.

Place

Signature of the authorized representative of Bidder

Name -----

Date

Designation-----

Company seal-----

<b>Project</b>	<b>765/400KV (UPPTCL) NEW SUBSATATION AT AGRA</b>	<b>TB-376-522-01 Rev 00</b>	
<b>System</b>	<b>FIRE FIGHTING SYSTEM</b>		
<b>Owner</b>	<b>UPPTCL</b>		
<b>Customer</b>	<b>POWER GRID CORPORATION OF INDIA LTD</b>		
<b>Purchaser</b>	<b>BHEL (TRANSMISSION BUSINESS GROUP)</b>		

## SCHEDULE-2

### DETAILS OF CONTACT PERSON BOTH TECHNICAL AND COMMERCIAL

Name

Address for correspondence

Phone No.

Fax No.

Email

Place

Signature of the authorized representative of Bidder

Date

Name-----

Designation-----

Company seal -----

Note: Continuation sheets of like size and format may be used as per the Bidder's Requirement and shall be annexed to this schedule.

<b>Project</b>	<b>765/400KV (UPPTCL) NEW SUBSATATION AT AGRA</b>	<b>TB-376-522-01 Rev 00</b>	
<b>System</b>	<b>FIRE FIGHTING SYSTEM</b>		
<b>Owner</b>	<b>UPPTCL</b>		
<b>Customer</b>	<b>POWER GRID CORPORATION OF INDIA LTD</b>		
<b>Purchaser</b>	<b>BHEL (TRANSMISSION BUSINESS GROUP)</b>		

### SCHEDULE -3

#### ENCLOSURES TO SPECIFICATION

a) **List of approved makes (Please refer section2, Powergrid's specification-APPENDIX-V)**

b) **DRAWINGS**

1. LAYOUT PLAN AND SECTIONAL ELEVATION FOR 765/400KV AGRA UPPTCL (NEW) SUB-STATION  
*DRG. NO. TB-0-376-316-002, REV-01*
2. CIVIL ARCHITECHTURAL/ STRUCTURAL DRAWING FOR STANDARD CONTROL BUILDING (PLAN & ELEVATION)  
*DRG. NO.: C-ENGG\_NR-1-AGRA-CRB-ARCH-01, 02, 03 & 04, REV-0.*
3. CIVIL ARCHITECHTURAL/ STRUCTURAL DRAWING FOR FIRE FIGHTING PUMP HOUSE BUILDING (PLAN, SECTIONS & ELEVATIONS) & FIRE WATER RESERVOIR  
*DRG. NO. C/ENGG/STD/FFPH-01 TO C/ENGG/STD/FFPH-15*
4. OGA FOR 500 MVA AUTO-TRANSFORMER (TBEA- Make for estimation purpose only)  
*DRG. NO.TBEA-500-765T-A0001-01*
5. OGA OF 80 MVAR REACTOR  
*DRG. NO. L01-0466*
6. OGA of 125 MVAR REACTORS  
*DRG. NO.34690001389, REV-01*
7. *STANDARD SWITCHYARD AC PANEL ROOM DRAWING*  
*DRG. NO. C-ENGG-STD-PR-ARCH-3000, REV-0*