

CLAUSE NO.

TECHNICAL REQUIREMENTS



The enclosures shall be constructed of 3 mm sheet plate and shall be of modular construction with one or more modules and two end assemblies bolted together to form an enclosure. Double inter locking doors shall be provided. The doors shall be the three-point locking type constructed of not less than 1.6 mm thick steel. Doors shall have concealed quick removal type pinned hinges and locking handles. Door locks shall accept the same key.

Gaskets shall be used between all mating sections to achieve protection class of IP-55.

The instrument racks shall be free standing type constructed of suitable 5 mm thick channel frame of steel and shall be provided with a canopy to protect the equipment mounted in racks from falling objects, water etc. The canopy shall not be less than 3 mm thick steel, and extended beyond the ends of the rack. Bulk heads, especially designed to provide isolation from process line vibration shall be provided. Exact fabrication details shall be as finalized during detailed engineering stage. The junction box for racks also shall conform to IP 55 protection class.

Enclosures/racks shall be reinforced as required to ensure true surface and to provide adequate support for instruments and equipment mounted therein. Centre posts or any member which would reduce access shall not be provided.

Each transmitter enclosure housing instruments requiring purge air for continuous air purging, shall be provided with common purge air header, redundant air filter regulators of sufficient capacity, required pressure gauges, valves, fittings, SS tubing and individual purge meters for each purge line etc. as required and indicated in Instrument Installation drawings enclosed herewith.

A 15 mm NB service air header shall be furnished in each instrument enclosure housing air & flue gas and coal mill instruments. The header shall be furnished complete with a pressure regulating valve, pressure gauge, and quick disconnect connections. A hose for connecting each header to the draft instrument line four-way valves shall be furnished. The hose shall be self-storing nylon tubing having a burst pressure of 15 kg/sq. cm. The size of the hose shall be 1/2" minimum. The service air header shall originate at a bulkhead penetration or fitting located on one of the bulkhead plates.

The contractor shall prepare the piping drawings and the general arrangement layout drawings for each of the enclosures and racks. Special attention shall be given in the piping layout to avoid air traps in liquid filled piping or water pockets in piping intended to be dry. Drawings shall indicate the arrangement of all equipment, piping, valves and fittings within, the enclosure/racks and shall be subject to Employer's approval.

All liquid filled blow down lines, except those measuring vacuum shall be connected to a two inch header which is extended through one end of the enclosure and turned downward for directing the blow down into a drain. The material of the blow down header shall be carbon steel as per ASTM A 106 Gr. C.

The Contractor shall submit to the Employer with his proposal a copy of his welding procedure specification together with proof of his compliance with the latest applicable welding ANSI code. Prior to any welding being performed, the Contractor shall submit the qualifications of the craftsmen who will perform the work.

LARA STPP (2x800MW) /  
DARLIPALI STPP-I (2 x 800MW) /  
GAJMARA STPP-I (2x 800MW) /  
KUDGI STPP-I (3 x 800MW) /  
STEAM GENERATOR PACKAGE

TECHNICAL SPECIFICATION  
SECTION-VI  
BID DOC NO.: CS-9548/ 9549/ 9566/  
9573-102-2

PART - B  
SUB-SECTION-IV  
I-6 (PROCESS  
CONNECTION & PIPING)

PAGE 5 OF 6

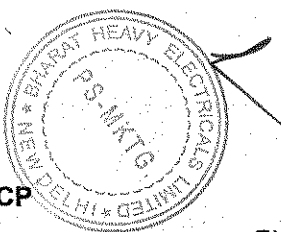

7.00.00 TABLE PCP



System/Line Description	Piping Class	Schedule (Size)	Materials for Fitting/Valve Body	Valve Material	Stem	Rating of Piping/ Fittings	Pr. Class of Valve
Main Steam/ Upstream of HP bypass and Auxiliary Steam Pressure reducing valve, Drum Level	A	XXS (1/2 inch)	(Note-2)	(Note-2)		9000 lb	3000 SPL
BFP disch, superheater attemperator, spray to PRDS, Phosphate dozing pp disch, BCW pump	B	160 (1/2 inch)	ASTM-A105	ASTM-A-182 Gr.F6a		6000 lb	2500
Reheater attemperator	C	160 (1/2 inch)	ASTM-A105	-do-		6000 lb	1500
Hot Reheat/ down stream of Aux. Steam press. Reducing valve upto desuper heater/ Flash tank drain manifold, HP heater level.	D	160 (1/2 inch)	ASTM-A182 22	Gr.F- (Note-2)		3000 lb	900
Cold reheat upto Tee-off for HP Bypass / Extraction steam to HPH	E	80 (1/2 inch)	ASTM-A182 22	Gr.F- ASTM-A-182 Gr.F6a		3000 lb	800
Cold reheat down steam of Tee-off (HP Bypass)	F	80 (1/2 inch)	ASTM-A105	-do-		3000 lb	800
BFP suction, Condensate System/ Extraction to LPH/ Ext-4 to BFPT, Deaerator/ auxiliary steam, service air, inst air, ECW pump, ACW pump and other low pr water services	G	80 (1/2 inch)	ASTM-A105	-do-		3000 lb	800
Air/ Flue gas outside furnace	M	80 (3/4 inch)	ASTM-A105	-do-		3000 lb	800
Air/ Flue gas inside furnace	N	80 (3/4 inch)	ASTM-A182 22	Gr. F- -do-		3000 lb	800

169

NOTE:

- 1 Rating of piping/fittings/valves etc. is subjected to the final design pressure & temperature during the detailed engineering.
- 2 Specification for fittings and valves in this table are minimum requirement. Bidder to provide fittings and valves meeting process requirements and as per piping specified in Mechanical Sub-Section- Power Cycle piping System & LPP. Materials for fittings, specialties and valves shall be compatible with process pipe material.

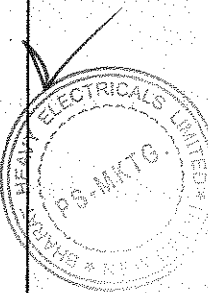
LARA STPP (2x800MW) / DARLIPALI STPP-I (2 x 800MW) / GAJMARA STPP-I (2x 800MW) / KUDGI STPP-I (3 x 800MW) STEAM GENERATOR PACKAGE	TECHNICAL SPECIFICATION SECTION-VI BID DOC. NO.: CS-9548/ 9549/ 9566/ 9573-102-2	PART - B SUB-SECTION-IV I-6 (PROCESS CONNECTION & PIPING)	PAGE 6 OF 6
---	---	---	-------------

CLAUSE NO.	<b>TECHNICAL REQUIREMENTS</b> 		
9.03.00	Bidder shall furnish two completely new sets of cable termination kits like Crimping tools, etc., which are required for maintenance of the system as per the type of termination used.		
9.04.00	Cables, which terminate in cabinets of draw out sections shall have sufficient cable coiled in the bottom of the cabinet to permit full withdrawal of draw out sections without disconnecting the cables. When prefabricated cables with factory connectors on both ends are longer than required, the excess cable shall be coiled in the bottom of one or both termination cabinets.		
9.05.00	No splices shall be made in conductors for instrument and control circuits except where required at connections to devices equipped with factory installed pigtails. Such splices shall be made only in approved splicing boxes of fitting with removable cover. The splices shall be made with sufficient slack left in the wires to permit withdrawal of the splice from the splicing box for ease of future disconnection of the splices. All exposed conductor or connector surfaces shall be covered with a minimum of three half-lapped layers of all weather vinyl plastic electrical tape. Taping shall extend a minimum of two cable diameters over the cable jacket and a similar distance over the other insulation or connections requiring insulation.		
9.06.00	The Bidder shall be responsible for proper grounding of all equipment under C&I package. Further, proper termination of cable shields shall be verified and the grounding of the same shall be coordinated so as to achieve grounding of all instrumentation cable shields at same potential. This shall be completed prior to system tests. All the cables etc. required for grounding of all equipments supplied under this package are to be supplied by the Bidder.		
9.07.00	The Contractor shall take full care while laying / installing cables as recommended by cable manufacturers regarding pulling tensions and cable bends. Cables damaged in any way during installation shall be replaced at the expense of the Contractor.		
<b>10.00.00</b>	<p><b>FIELD MOUNTED LOCAL JUNCTION BOXES</b></p> <ul style="list-style-type: none"> <li>(i) No. of ways 12/24/36/48/64/72/96/128 with 20% spares terminals.</li> <li>(ii) Material and Thickness 4mm thick Fiberglass Reinforced Polyester (FRP).</li> <li>(iii) Type Door gasket shall be of synthetic rubber.</li> <li>(iv) Mounting clamps and accessories Suitable for mounting on walls, columns, structures etc. The brackets, bolts, nuts, screws, glands and lugs required for erection shall be of brass, included in Bidders scope of supply.</li> <li>(v) Type of terminal blocks Rail mounted cage-clamp type suitable for conductor size upto 2.5 mm<sup>2</sup>. A M6 earthing stud shall be provided.</li> <li>(vi) Protection Class IP: 55 minimum for indoor &amp; IP-65 minimum for outdoor applications.</li> <li>(vii) Grounding To be provided.</li> <li>(viii) Color To be decided during detailed engineering &amp; subject to Employer's approval.</li> </ul>		
		<b>TECHNICAL SPECIFICATION SECTION-VI</b> <b>BID DOC NO.: CS-9548/ 9549/ 9566/ 9573-102-2</b>	<b>PART - B</b> <b>SUB-SECTION-IV: I7</b> <b>(INSTR. AND POWER SUPPLY CABLE)</b> <b>PAGE 12 OF 14</b>

This document is the property of NATIONAL THERMAL POWER CORPORATION LTD. No part of this document will be reproduced by any means without the written permission.

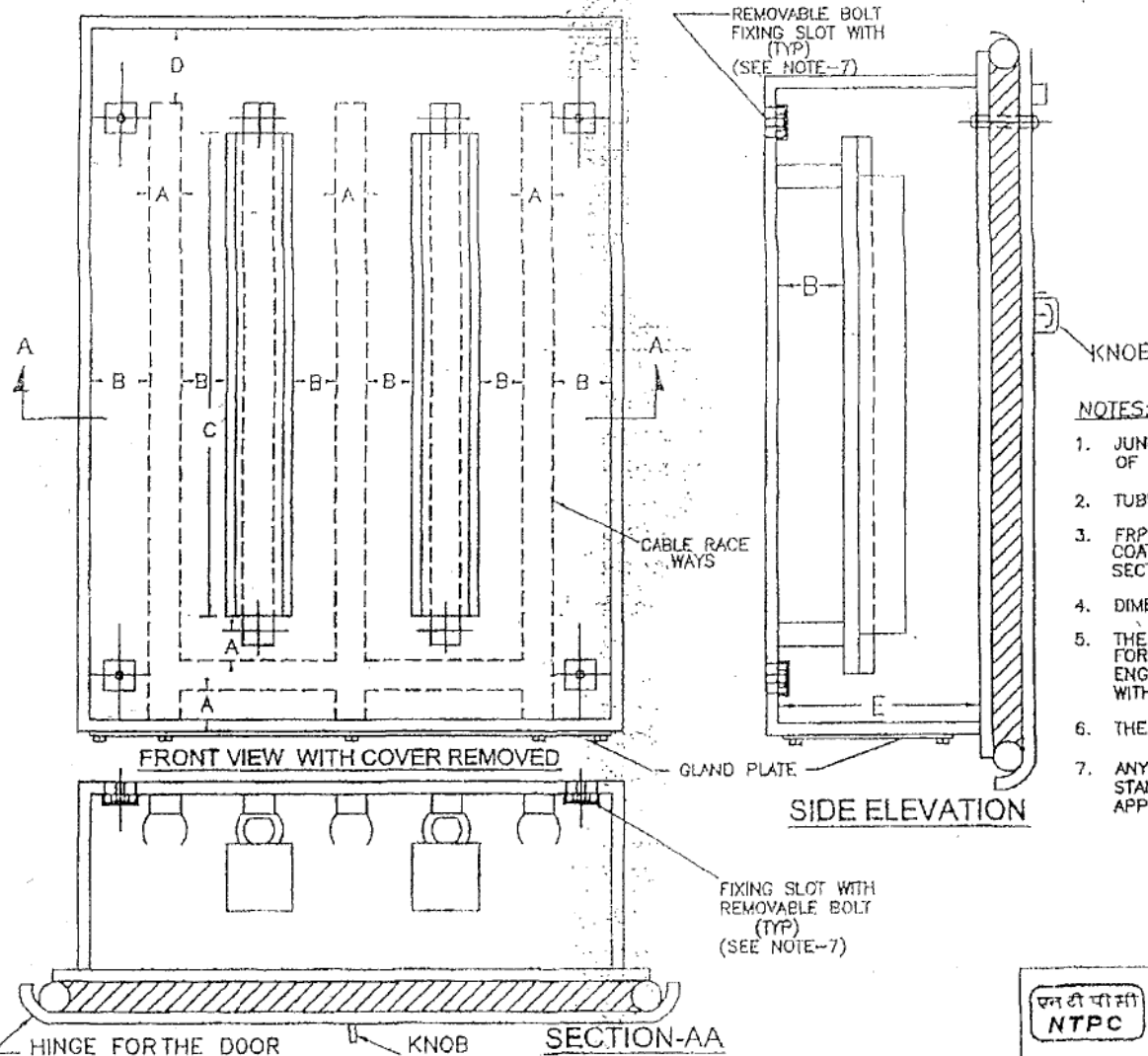

- A - 75 mm
- B - 25 mm
- C - SEE NOTE-4
- D - 100 mm
- E - 150 mm

**NOTES:-**

1. JUNCTION BOXES SHALL HAVE GLAND PLATES AT THE BOTTOM OF THE BOX ONLY.
2. TUBULAR TYPE GASKETS WILL BE USED.
3. FRP JUNCTION BOXES, SHALL BE PROVIDED WITH POLYETHYLENE COATING. ALSO REFER SUB SECTION INST CABLE, PART-B SECTION-VI FOR DETAILS.
4. DIMENSION OF 'F' SHALL BE BASED ON NO. OF TERMINAL BLOCKS.
5. THE EXACT TYPE & DIMENSION OF JUNCTION BOXES TO BE USED FOR A PARTICULAR APPLICATION SHALL BE AS DECIDED DURING DETAIL ENGG. STAGE AND SHALL BE SUBJECT TO EMPLOYER'S APPROVAL WITHOUT ANY PRICE REPERCUSSION.
6. THE KNOB FOR ALL THE JUNCTION BOXES SHALL BE IDENTICAL.
7. ANY TYPE OF SEALED FIXING ARRANGEMENT AS PER MANUFACTURER'S STANDARD CAN ALSO BE PROVIDED SUBJECT TO EMPLOYER'S APPROVAL.

FOR TENDER PURPOSE ONLY

नेशनल थर्मल पावर कारपोरेशन लिमिटेड  
**National Thermal Power Corporation Ltd.**  
 (A GOVERNMENT OF INDIA ENTERPRISE)  
 ENGINEERING DIVISION

REV. NO.	DESCRIPTION	DRAWN	DESIGN	CHKD.	U	E	C	C&I	ARCH.	APPD	DATE
D	GENERALLY REVISED		JU	KS							30.11.05
C	GENERALLY REVISED		JU	KS							04.08.05
B	GENERALLY REVISED	S.K.	A.R	PS							04.08.05
A	FIRST ISSUE	S.K.	A.R	PS							04.08.05
CLEARED BY											

PROJECT		TYPICAL THERMAL POWER PLANT	
TITLE		LOCAL JUNCTION BOX CONNECTION DETAILS	
SIZE	SCALE	DRG. NO.	REV. NO.
A3	H.T.S.	0000-999-POI-A-017	D

This document is the property of NATIONAL THERMAL POWER CORPORATION LTD. No part of this document will be reproduced by any means without the written permission.

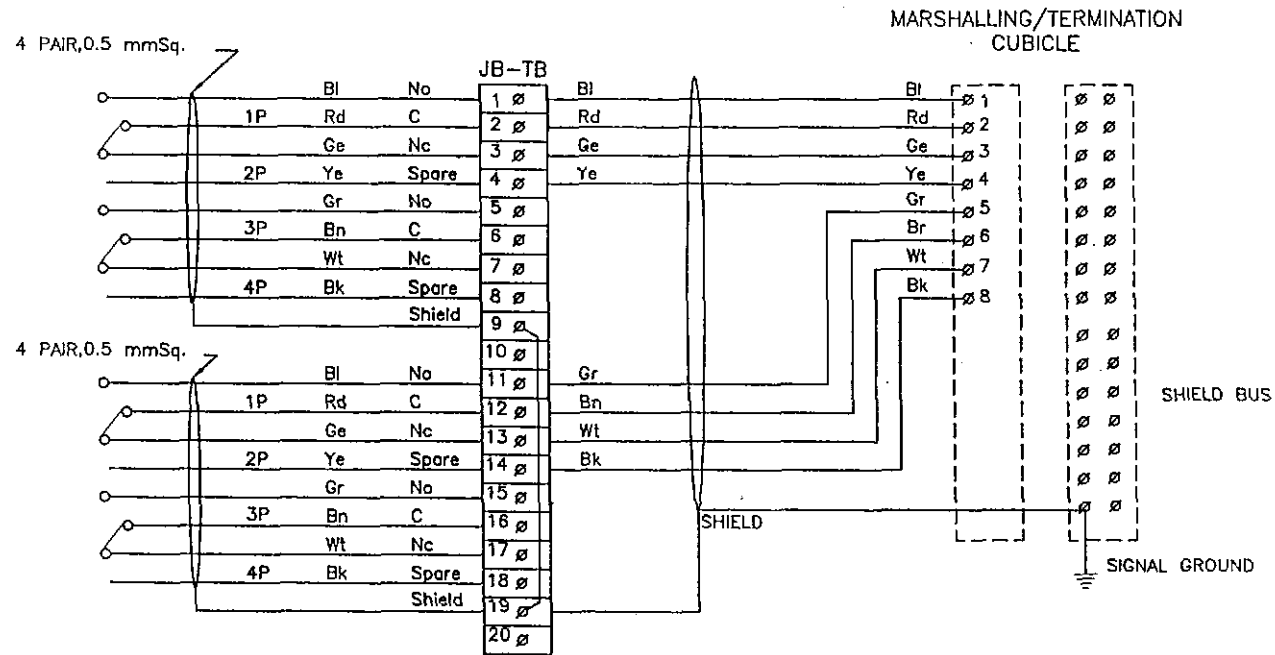

FOR TENDER PURPOSE ONLY



**एन टी पी सी लिमिटेड**  
**NTPC LIMITED**  
 ( A GOVERNMENT OF INDIA ENTERPRISE )  
 ENGINEERING DIVISION

PROJECT		TYPICAL THERMAL POWER PROJECT		
TITLE		INTERFACING OF FIELD INSTRUMENTS/ SWGR SWITCH (COC) TERMINATION DETAILS		
REV. NO.	DESCRIPTION	DRAWN	DESIGN	CHKD.
A	FIRST ISSUE	<i>[Signature]</i>	<i>[Signature]</i>	<i>[Signature]</i>
		M	E	C
		C&I	ARCH.	APPD.
				DATE
				29.04.06
SIZE	SCALE	DRG. NO.	REV. NO.	
A3	NTS	0000-999-POI-A-065	A	
SH 01 2754				

This document is the property of NATIONAL THERMAL POWER CORPORATION LTD. No part of this document will be reproduced by any means without the written permission.

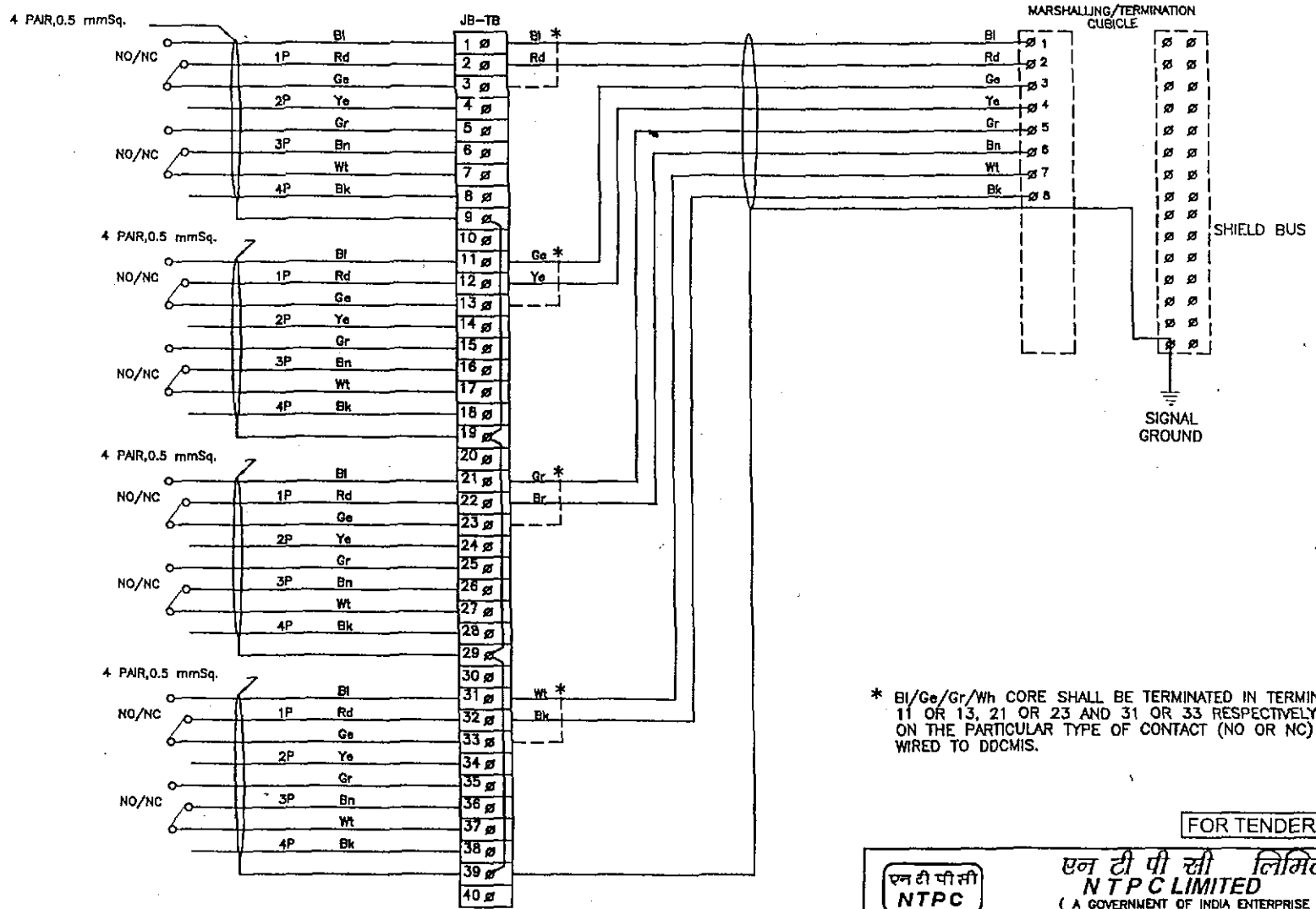

\* BI/Ge/Gr/Wt CORE SHALL BE TERMINATED IN TERMINAL 1 OR 3, 11 OR 13, 21 OR 23 AND 31 OR 33 RESPECTIVELY DEPENDING ON THE PARTICULAR TYPE OF CONTACT (NO OR NC) IS TO BE WIRED TO DDCMIS.

FOR TENDER PURPOSE ONLY

		<b>एन टी पी सी लिमिटेड</b> <b>NTPC LIMITED</b> ( A GOVERNMENT OF INDIA ENTERPRISE ) ENGINEERING DIVISION	
PROJECT		TYPICAL THERMAL POWER PROJECT	
TITLE		INTERFACING OF FIELD INSTRUMENTS SWITCH TERMINATION DETAILS NO/NC	
REV. NO.	DESCRIPTION	DRAWN	DESIGN
A	FIRST ISSUE	<i>[Signature]</i>	<i>[Signature]</i>
REV. NO.	DESCRIPTION	CHKD.	M
			E
			C
			C&I
			ARCH.
			APPD
			DATE
			29.04.06
SIZE	SCALE	DRG. NO.	REV. NO.
A3	NTS	0000-999-POI-A-065	A

CLEARED BY

This document is the property of National Thermal Power Corporation Ltd. No part of this document will be reproduced by any means without the written permission.

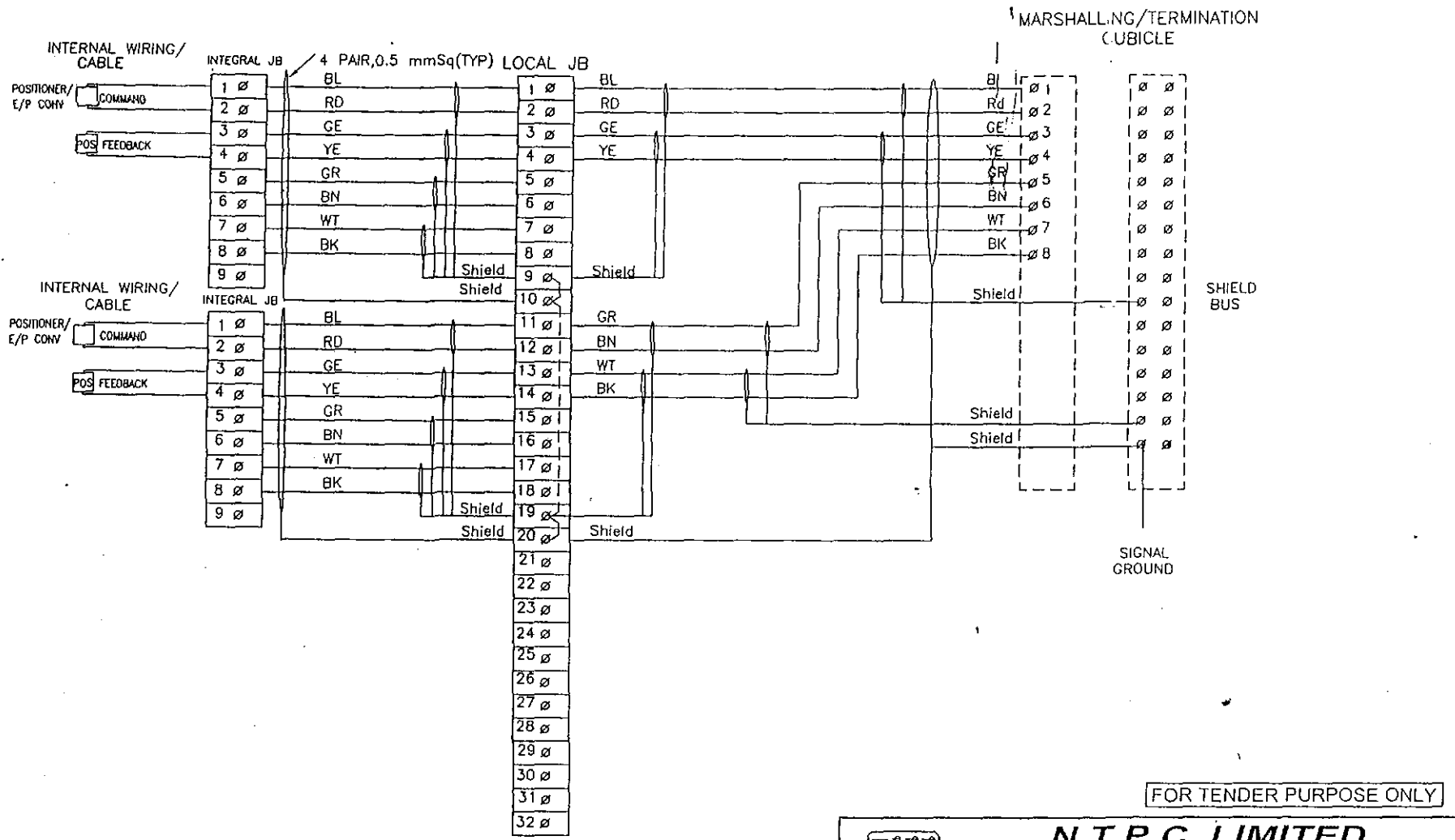

FOR TENDER PURPOSE ONLY

**NTPC LIMITED**  
(A GOVERNMENT OF INDIA ENTERPRISE)  
 ENGINEERING DIVISION

REV. NO.	DESCRIPTION	DRAWN	DESIGN	CHKD.	M	E	C	C&I	ARCH.	APPD	DATE
B	INTERNAL WIRING/INTEGRAL JB INDICATED	<i>M.A.</i>	<i>M.A.</i>	<i>M.A.</i>							29.08.06
A	FIRST ISSUE	<i>M.A.</i>	<i>M.A.</i>	<i>M.A.</i>							29.04.06

PROJECT	TYPICAL THERMAL POWER PROJECT		
TITLE	INTERFACING OF FIELD INSTRUMENTS CONTROL VALVE		
SIZE	SCALE	DRG. NO.	REV. NO.
A3	NTS	0000-999-POI-A-065	B
SH 03 OF 14			

This document is the property of NATIONAL THERMAL POWER CORPORATION LTD. No part of this document will be reproduced by any means without the written permission.

INTERNAL WIRING/2 PAIR,0.5 mmSq.(TYP)

INTEGRAL JB OF LIE/LIR  
(4-20mA)

MARSHALLING/TERMINATION  
CUBICLE

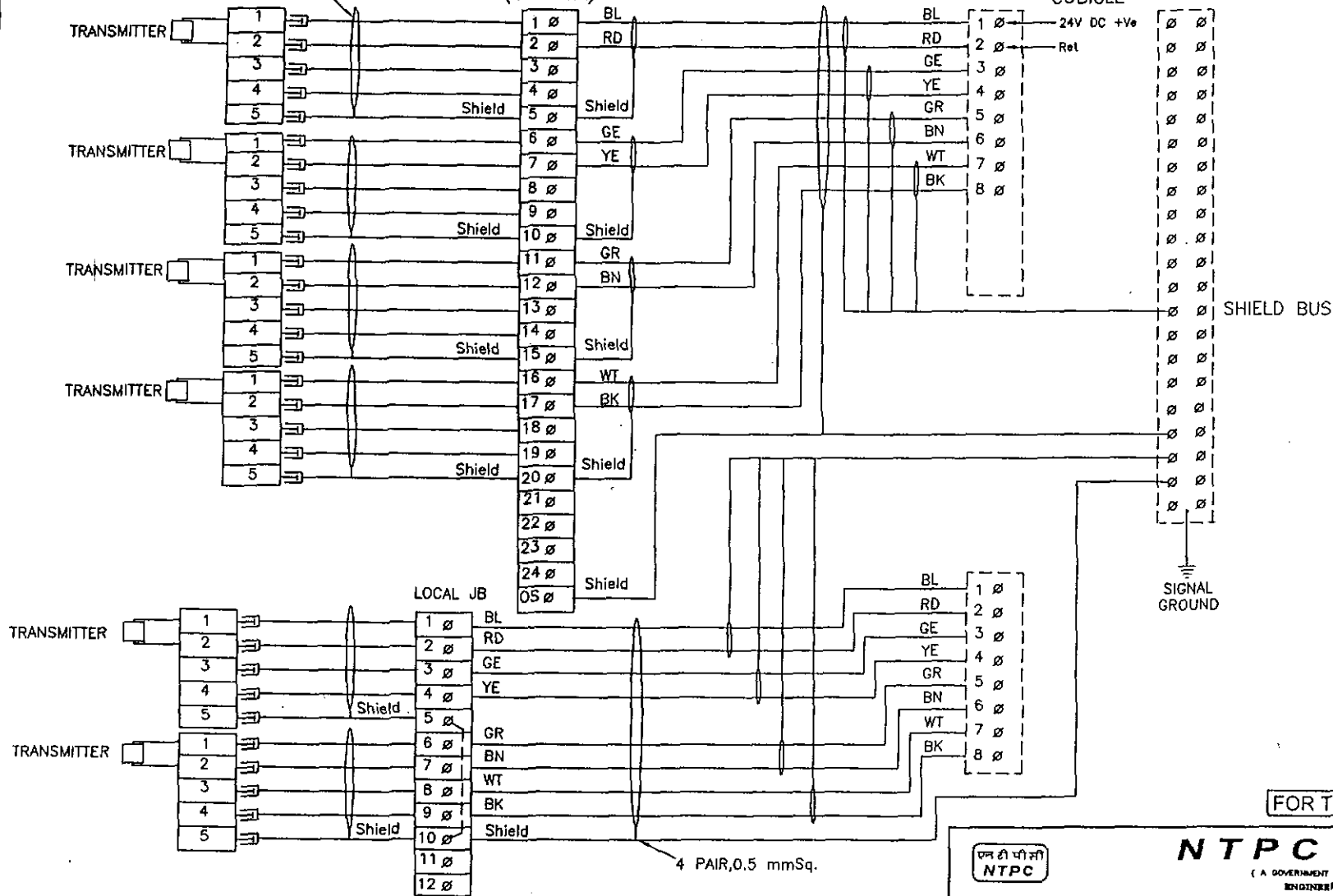

FOR TENDER PURPOSE ONLY



**NTPC LIMITED**

( A GOVERNMENT OF INDIA ENTERPRISE )  
ENGINEERING DIVISION

										PROJECT		TYPICAL THERMAL POWER PROJECT					
INTERNAL WIRING FOR LIE/LIR MOUNTED SHOWN										TITLE		INTERFACING OF FIELD INSTRUMENTS					
WIRING OF STAND ALONE TXTR SHOWN												4-20mA					
FIRST ISSUE																	
REV. NO.	DESCRIPTION			DRAWN	DESIGN	CHKD.	M	E	C	C&I	ARCH.	APPD	DATE	SIZE	SCALE	DRG. NO.	REV. NO.
							CLEARED BY							A3	NTS	0000-999-POI-A-065	278 B
SH 04 OF 14																	

This document is the property of NATIONAL THERMAL POWER CORPORATION LTD. No part of this document will be reproduced by any means without the written permission.

MARSHALLING/ TERMINATION CUBICLES

4 PAIR, 0.5 Sq. m MCC/SWGR D

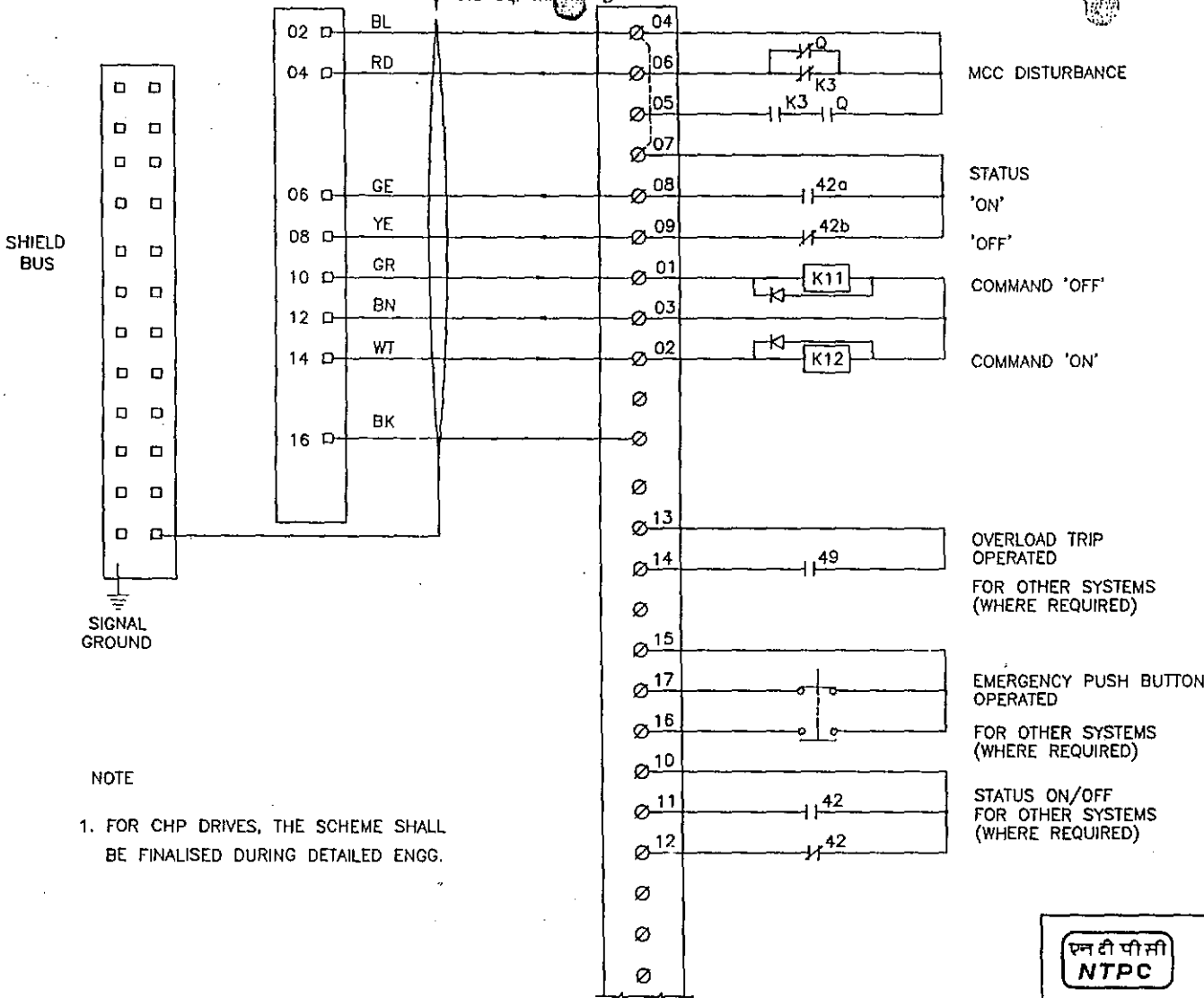

NOTE

1. FOR CHP DRIVES, THE SCHEME SHALL BE FINALISED DURING DETAILED ENGG.

FOR TENDER PURPOSE ONLY

**एन टी पी सी लिमिटेड**  
**NTPC LIMITED**  
 ( A GOVERNMENT OF INDIA ENTERPRISE )  
 ENGINEERING DIVISION

										PROJECT		TYPICAL THERMAL POWER PROJECT			
										TITLE		INTERFACING OF FIELD INSTRUMENTS INTERFACE OF DDCMIS-WITH MCC/SWGR/ACTUATOR (LT MOTORS)			
REV. NO.	DESCRIPTION	DRAWN	DESIGN	CHKD.	M	E	C	C&I	ARCH.	APPD	DATE	SIZE	SCALE	DRG. NO.	REV. NO.
A	FIRST ISSUE										29.04.06	A3	NTS	0000-999-POI-A-065	A
CLEARED BY															

This document is the property of NATIONAL THERMAL POWER CORPORATION LTD. No part of this document will be reproduced by any means without the written permission.

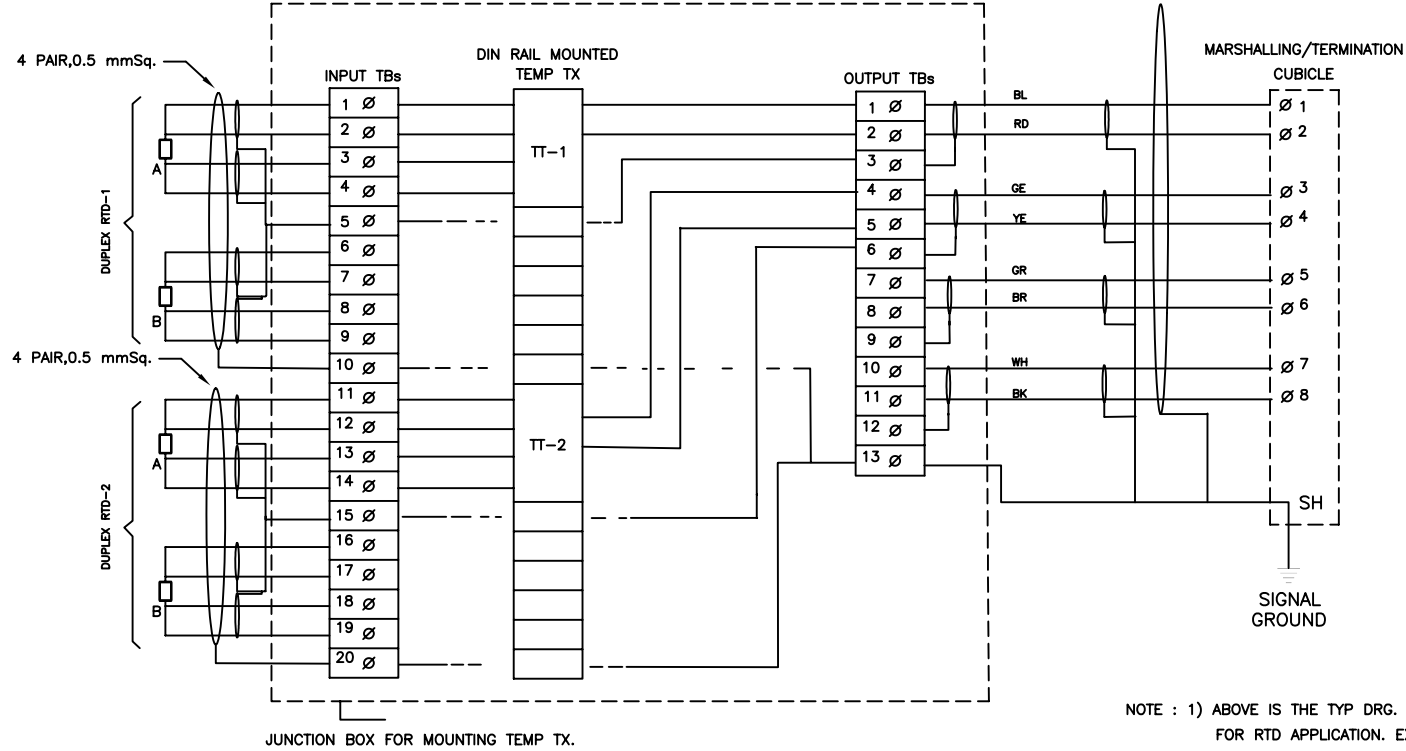

- NOTE : 1) ABOVE IS THE TYP DRG. FOR DIN RAIL MOUNTED TEMP TRANSMITTERS FOR RTD APPLICATION. EXACT TYPE OF TEMP TRANSMITTER SHALL BE AS PER PART-A OF SPECIFICATION.  
 2) THE EXACT GROUPING OF TEMP TXs SHALL BE FINALISED DURING DETAILED ENGG. STAGE.

FOR TENDER PURPOSE ONLY



**NTPC LIMITED**  
 ( A GOVERNMENT OF INDIA ENTERPRISE )  
**ENGINEERING DIVISION**

PROJECT	TYPICAL THERMAL POWER PROJECT														
TITLE	INTERFACING OF FIELD INSTRUMENTS TYPICAL RTD CONNECTION WITH TEMP TRANSMITTERS INJBS														
REV. NO.	DESCRIPTION	DRAWN	DESIGN	CHKD.	M	E	C	C&I	ARCH.	APPD	DATE	SIZE	SCALE	DRG. NO.	REV. NO.
A	FIRST ISSUE										29.04.06	A3	NTS	0000-999-POI-A-065	C
CLEARED BY											280	SH 06 OF 14			

This document is the property of NATIONAL THERMAL POWER CORPORATION LTD. No part of this document will be reproduced by any means without the written permission.

MARSH./TERM CUBICLE 4 PAIR 0.5 Sq. mm

MCC/SWGR D-

MCC/SWGR D-

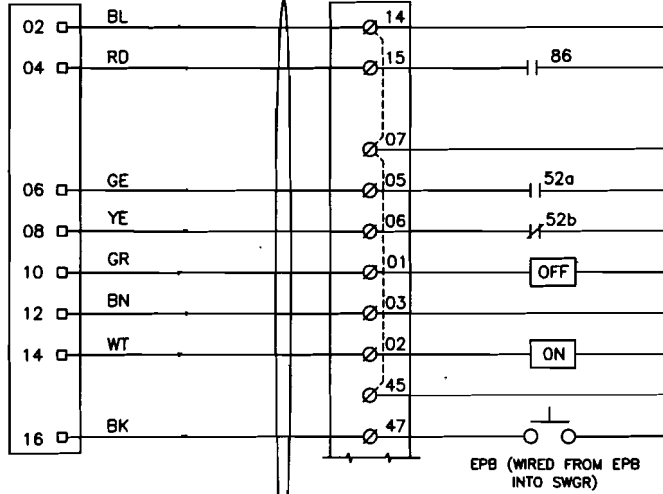

ELECT. PROTECTION OPERATED (RELAY/ MET CABINET)

STATUS ON } FROM BREAKER  
OFF }

COMMAND 'OFF' } 24 V SIGNAL FROM DDCMIS FOR SWGR RELAY/ MET CABINET  
COMMAND 'ON' }

EPB (WIRED FROM EPB INTO SWGR)

SHIELD BUS

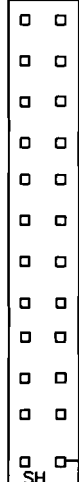

SIGNAL GROUND

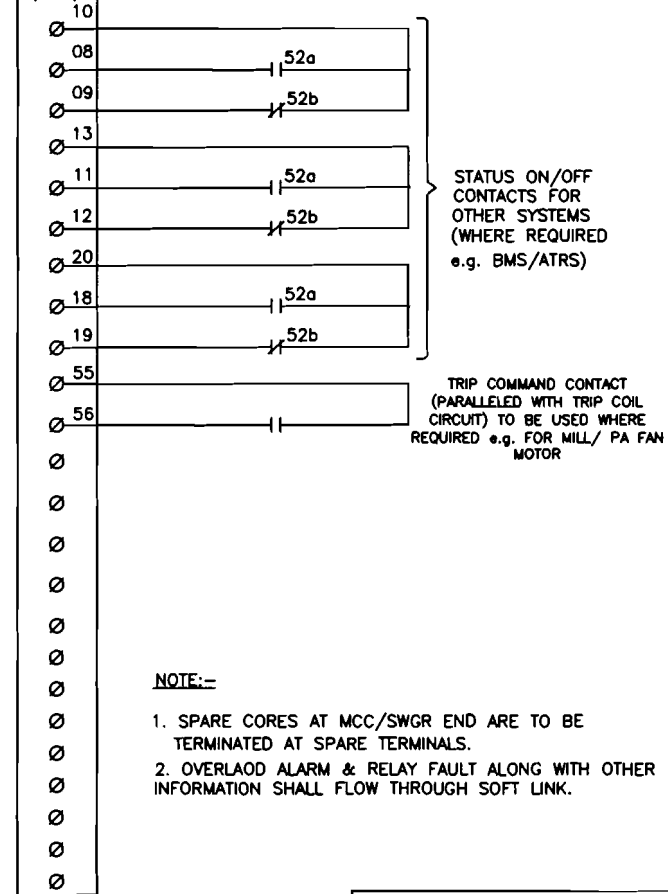

NOTE:-

1. SPARE CORES AT MCC/SWGR END ARE TO BE TERMINATED AT SPARE TERMINALS.
2. OVERLOAD ALARM & RELAY FAULT ALONG WITH OTHER INFORMATION SHALL FLOW THROUGH SOFT LINK.

FOR TENDER PURPOSE ONLY



एन टी पी सी लिमिटेड  
**NTPC LIMITED**  
( A GOVERNMENT OF INDIA ENTERPRISE )  
ENGINEERING DIVISION

PROJECT	TYPICAL THERMAL POWER PROJECT													
TITLE	INTERFACING OF FIELD INSTRUMENTS INTERFACE OF DDCMIS WITH MCC/SWGR/ACTUATOR (HT MOTORS)													
REV. NO.	DESCRIPTION	DRAWN	DESIGN	CHKD.	M	C	C&I	ARCH.	APPD.	DATE	SIZE	SCALE	DRG. NO.	REV. NO.
B	Revised for Numerical relay based SWGR									14.02.08	A3	NTS	0000-999-POI-A-065	B
CLEARED BY														

SH 07 OF 14

This document is the property of NATIONAL THERMAL POWER CORPORATION LTD. No part of this document will be reproduced by any means without the written permission.

Marshalling/ Termination Cubicle  
POST-A

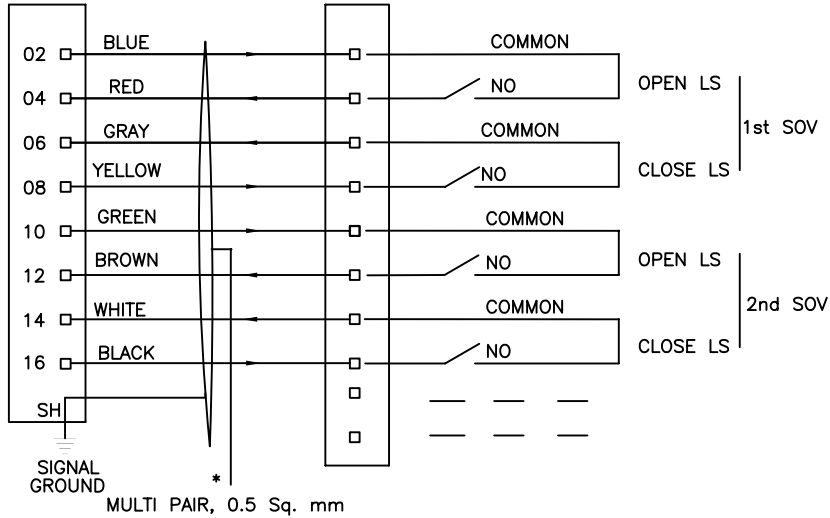

Marshalling/  
Termination Cubicle  
POST-B

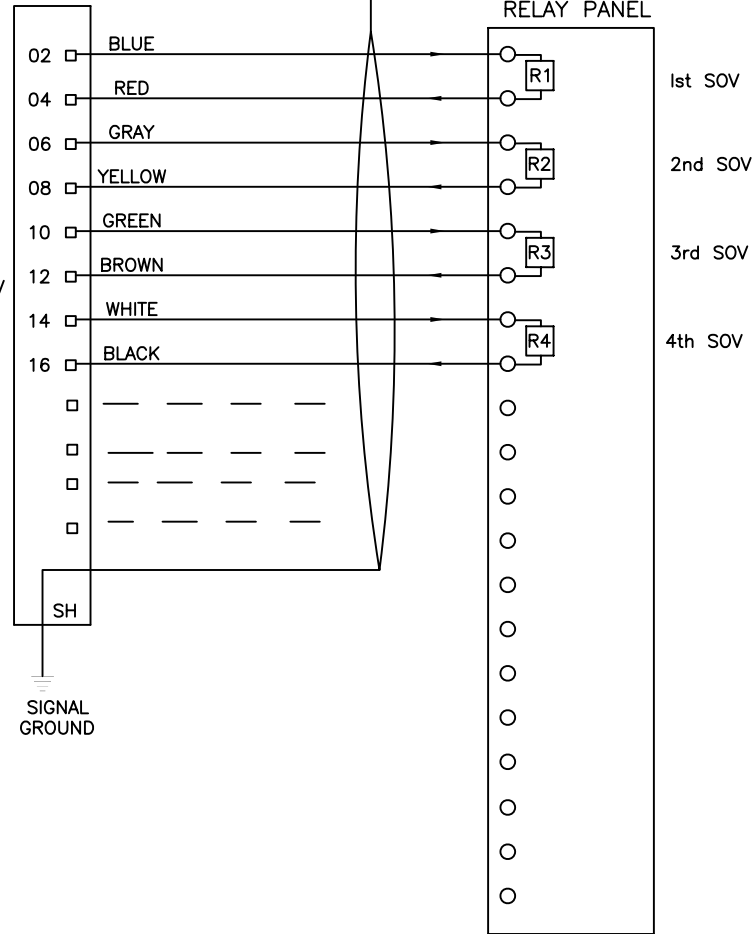

- 1) \* FEEDBACKS OF SOVs CAN BE GROUPED IN FIELD JB AND MULTI PAIR CABLE IS TO BE USED FROM FIELD JB TO MARSHALLING/TERMINATION CUBICLE FOR FEEDBACKS OF GROUP OF SOVs. TYP ARRANGEMENT IS SHOWN FOR A GROUP OF TWO SOVs WITH OPEN AND CLOSE LIMIT SWITCHES.
- 2) NO. OF LIMIT SWITCHES/NO. OF CONTACT IN LIMIT SWITCHES SHALL BE PROVIDED FOR EACH VALVE AS PER SPEC. REQUIREMENT/ PHILOSOPHY FOR RESPECTIVE SYSTEM.
- 3) \*\* MULTIPAIR CABLE IS TO BE USED FOR CONNECTION OF COMMAND OUTPUTS FROM MARSHALLING/TERMINATION CUBICLE TO RELAY PANEL FOR A GROUP OF SOVs.

 नैशनल थर्मल पावर कारपोरेशन लिमिटेड  
**National Thermal Power Corporation Ltd.**  
 ( A GOVERNMENT OF INDIA ENTERPRISE )  
**ENGINEERING DIVISION**

PROJECT		TYPICAL THERMAL POWER PROJECT	
TITLE		INTERFACING OF FIELD INSTRUMENTS INTERFACE OF DDCMIS WITH MCC/SWGR/ACTUATOR (SINGLE COIL SOLENOID)	
REV. NO.	B	FIRST ISSUE	30.10.02
REV. NO.	DESCRIPTION		REV. NO.
SIZE	SCALE	DRG. NO.	REV. NO.
A3	NTS	0000-999-POI-A-065	C
CLEARED BY		282	SH 08 OF 14

This document is the property of NATIONAL THERMAL POWER CORPORATION LTD. No part of this document will be reproduced by any means without the written permission.

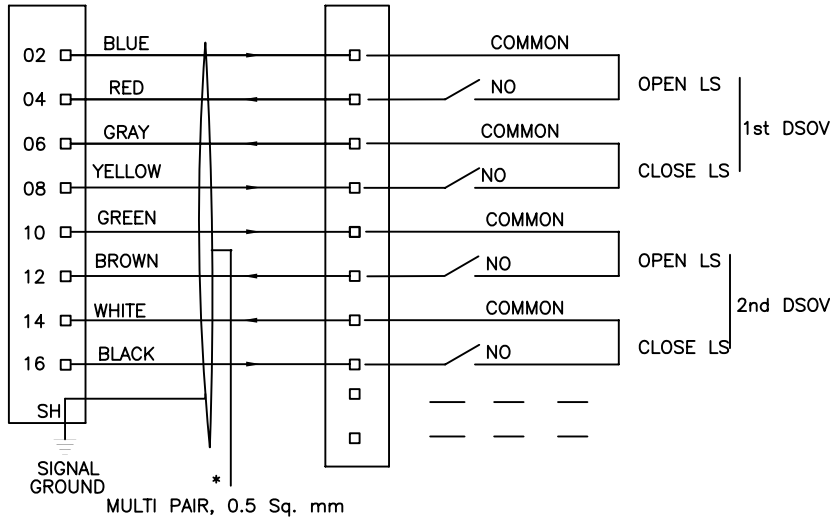

Marshalling/ Termination Cubicle  
POST-A

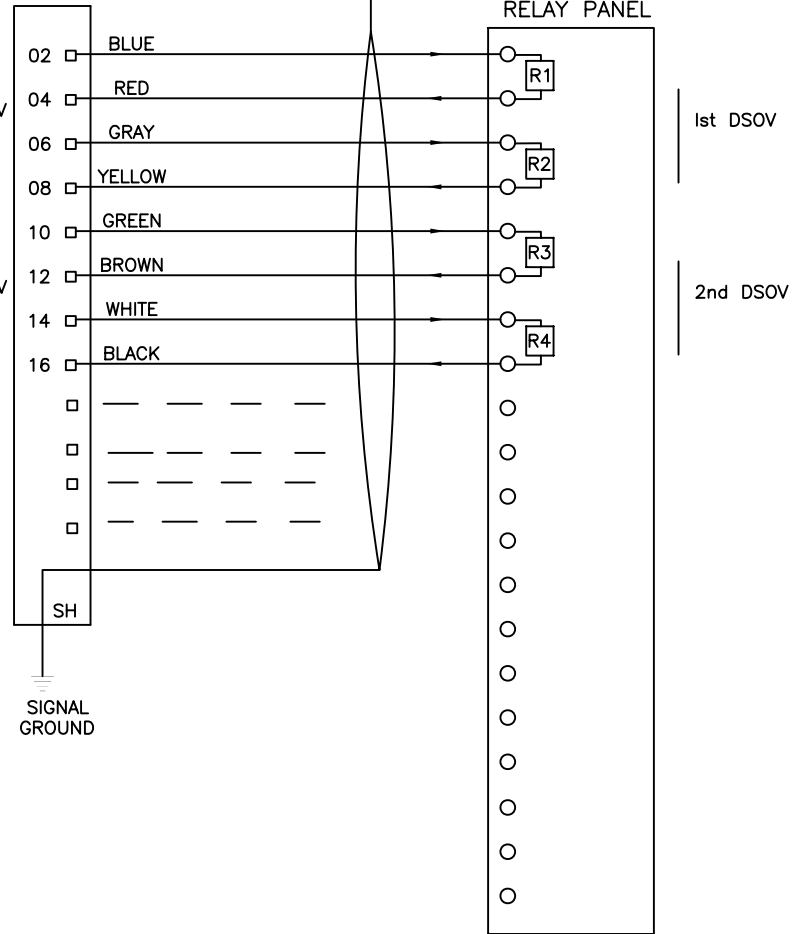

Marshalling/  
Termination Cubicle  
POST-B



- 1) \* FEEDBACKS OF DSOVs CAN BE GROUPED IN FIELD JB AND MULTI PAIR CABLE IS TO BE USED FROM FIELD JB TO MARSHALLING/TERMINATION CUBICLE FOR FEEDBACKS OF GROUP OF DSOVs. TYP ARRANGEMENT IS SHOWN FOR A GROUP OF TWO DSOVs WITH OPEN AND CLOSE LIMIT SWITCHES.
- 2) NO. OF LIMIT SWITCHES/NO. OF CONTACT IN LIMIT SWITCHES SHALL BE PROVIDED FOR EACH VALVE AS PER SPEC. REQUIREMENT/ PHILOSOPHY FOR RESPECTIVE SYSTEM.
- 3) \*\* MULTIPAIR CABLE IS TO BE USED FOR CONNECTION OF COMMAND OUTPUTS FROM MARSHALLING/TERMINATION CUBICLE TO RELAY PANEL FOR A GROUP OF DSOVs.

		नैशनल थर्मल पावर कार्पोरेशन लिमिटेड <i>National Thermal Power Corporation Ltd.</i> ( A GOVERNMENT OF INDIA ENTERPRISE ) ENGINEERING DIVISION	
PROJECT		TYPICAL THERMAL POWER PROJECT	
TITLE		INTERFACING OF FIELD INSTRUMENTS INTERFACE OF DDCMIS WITH MCC/SWGR/ACTUATOR (DOUBLE COIL SOLENOID)	
REV.NO.	DESCRIPTION	DRAWN	DESIGN
B	FIRST ISSUE		
		CHKD.	
		M	E
		C	C&I
		ARCH.	APPD
			DATE
			30.10.02
SIZE	SCALE	DRG. NO.	REV. NO.
A3	NTS	0000-999-POI-A-065	C
		283	
		SH 09 OF 14	

This document is the property of NATIONAL THERMAL POWER CORPORATION LTD. No part of this document will be reproduced by any means without the written permission.

MARSHALLING/  
TERMINATION CUBICLE

4 PAIR  
0.5 Sq. mm

MCC/SWGR

MCC/SWGR

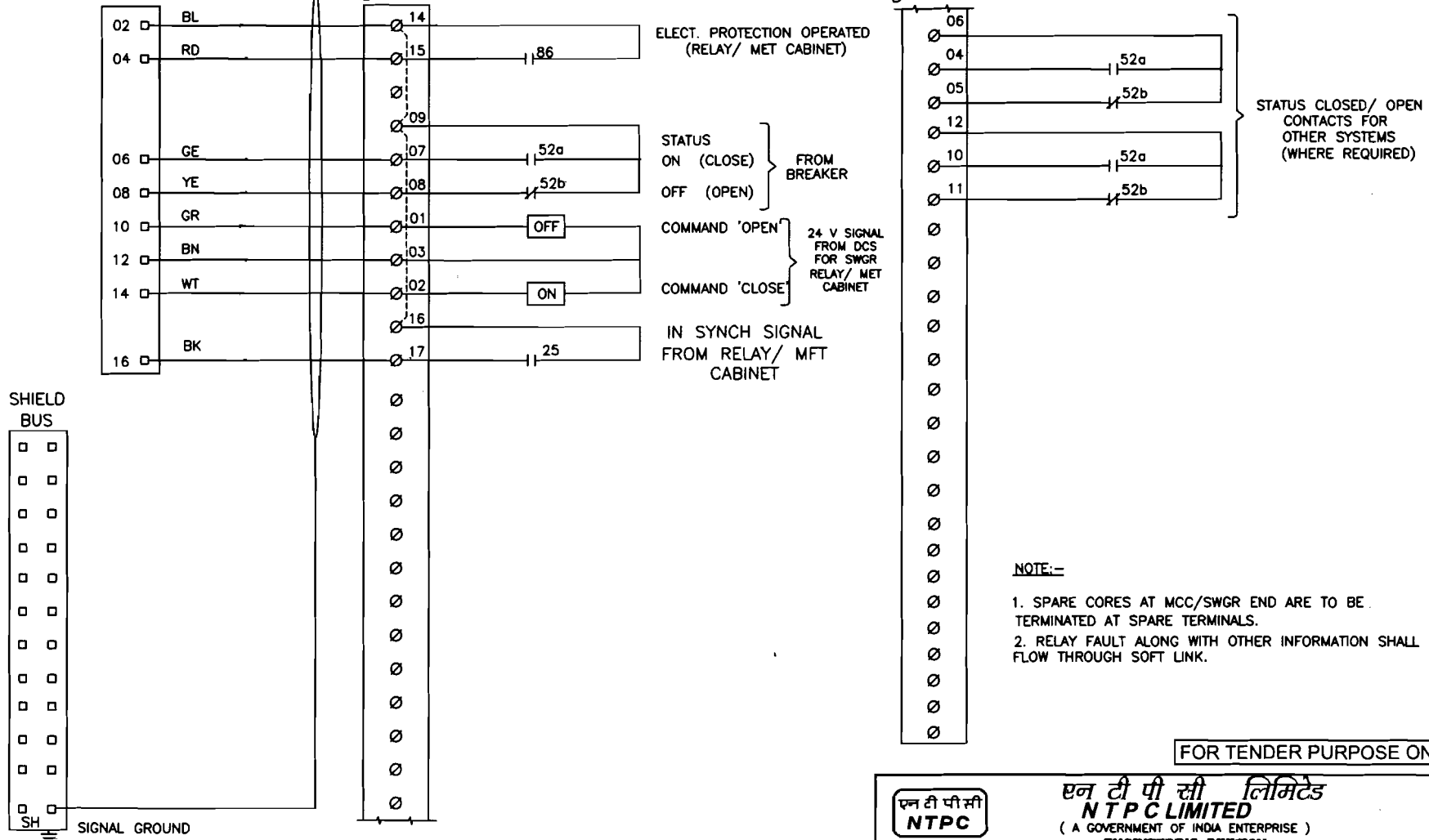

NOTE:-

1. SPARE CORES AT MCC/SWGR END ARE TO BE TERMINATED AT SPARE TERMINALS.
2. RELAY FAULT ALONG WITH OTHER INFORMATION SHALL FLOW THROUGH SOFT LINK.

FOR TENDER PURPOSE ONLY

एन टी पी सी  
NTPC

एन टी पी सी लिमिटेड  
NTPC LIMITED  
( A GOVERNMENT OF INDIA ENTERPRISE )  
ENGINEERING DIVISION

PROJECT	TYPICAL THERMAL POWER PROJECT		
TITLE	INTERFACING OF FIELD INSTRUMENTS INTERFACE OF DDCMIS WITH MCC/SWGR/ACTUATOR (Elect. Bkr. - Sync.-LT)		
DATE	14.02.08	SIZE	A3
SCALE	NTS	DRG. NO.	0000-405-POI-A-065
REV. NO.	B	REV. NO.	B
Cleared by		SH 10 OF 14	

REV. NO.	B	DESCRIPTION	Revised for Numerical Relay based SWGR.	DRAWN	DESIGN	CHKD.	M	E	C	C&I	ARCH.	APPD.	DATE	14.02.08
Cleared by														

This document is the property of NATIONAL THERMAL POWER CORPORATION LTD. No part of this document will be reproduced by any means without the written permission.

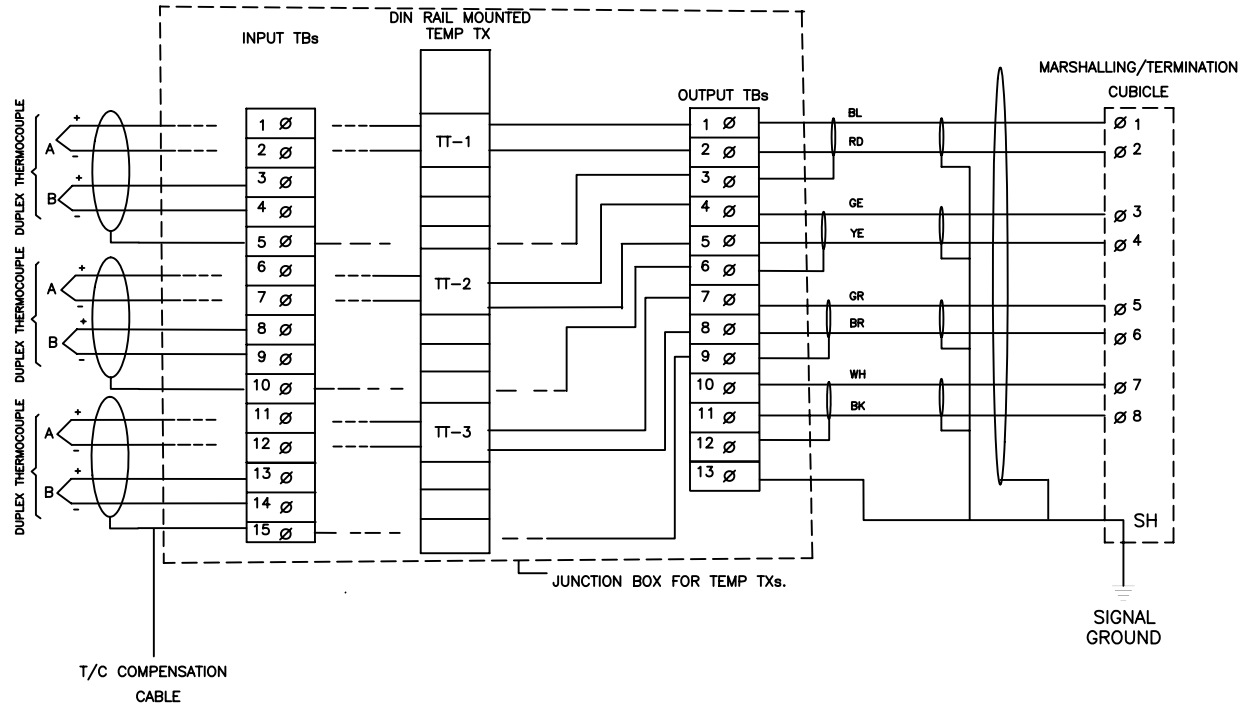

- NOTE: 1) ABOVE IS THE TYP DRG. FOR DIN RAIL MOUNTED TEMP TRANSMITTER FOR T/C APPLICATION. EXACT TYPE OF TEMP TRANSMITTERS SHALL BE AS PER PART-A OF SPECIFICATION.
- 2) THE EXACT GROUPING OF TEMP TXs SHALL BE FINALISED DURING DETAILED ENGG. STAGE.
- 3) AFTER GLANDING OF T/C CABLES ON JB, THE CABLE PAIR OF FIRST ELEMENT WILL BE DIRECTLY CONNECTED TO TT AND FOR CABLE PAIR OF SECOND ELEMENT LOOP SHALL BE KEPT, BEFORE TERMINATION AT INPUT TBs FOR FUTURE USE.

FOR TENDER PURPOSE ONLY



**NTPC LIMITED**  
( A GOVERNMENT OF INDIA ENTERPRISE )  
**ENGINEERING DIVISION**

PROJECT	TYPICAL THERMAL POWER PROJECT														
TITLE	INTERFACING OF FIELD INSTRUMENTS TYPICAL T/C CONNECTION WITH TEMP TXs IN JBs														
REV. NO.	DESCRIPTION	DRAWN	DESIGN	CHKD.	M	E	C	C&I	ARCH.	APPD	DATE	SIZE	SCALE	DRG. NO.	REV. NO.
A	FIRST ISSUE										29.04.06	A3	NTS	0000-999-POI-A-065	C
CLEARED BY											285	SH 11 OF 14			

This document is the property of NATIONAL THERMAL POWER CORPORATION LTD. No part of this document will be reproduced by any means without the written permission.

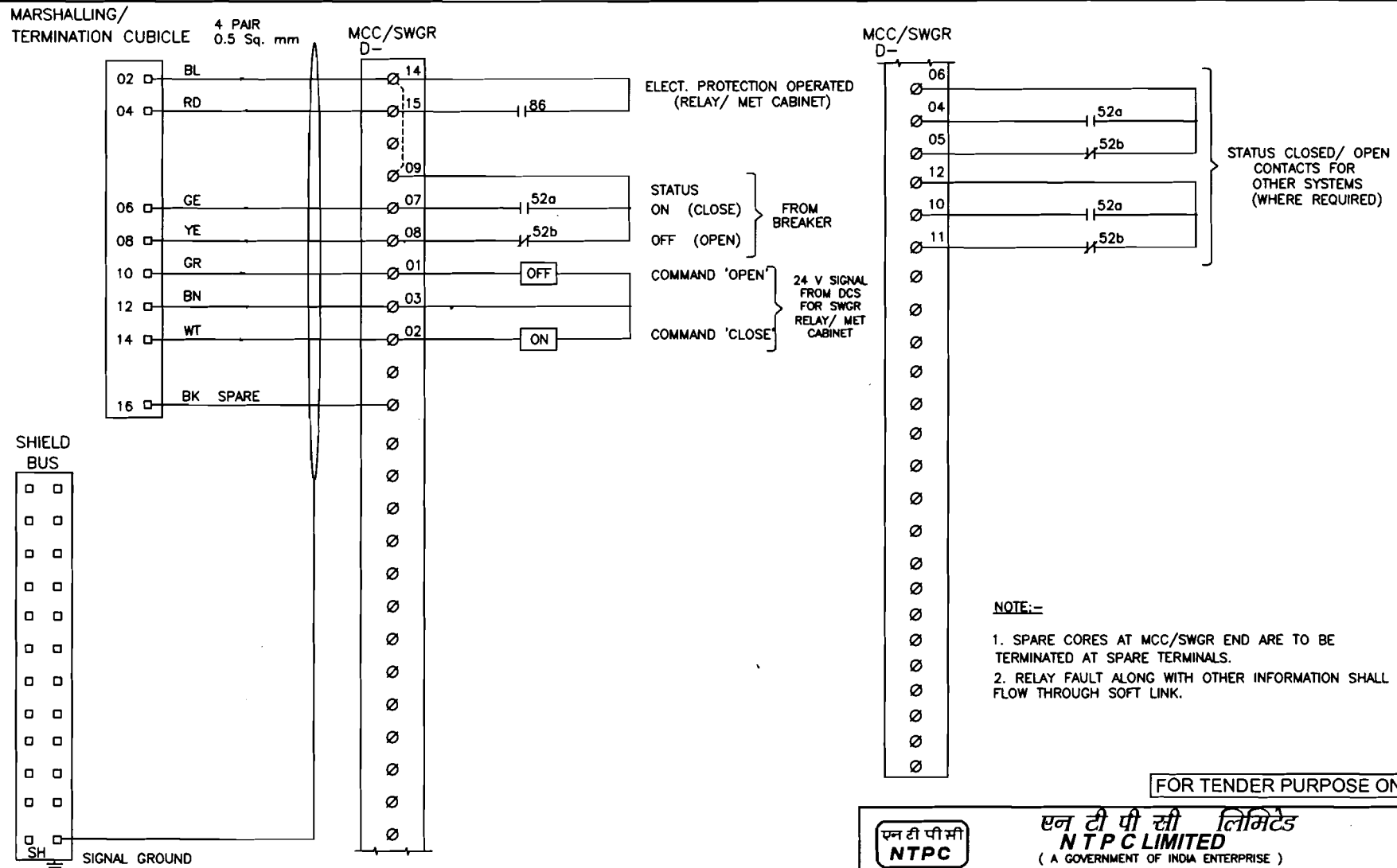

FOR TENDER PURPOSE ONLY

		<b>एन टी पी सी लिमिटेड</b> <b>NTPC LIMITED</b> ( A GOVERNMENT OF INDIA ENTERPRISE ) <b>ENGINEERING DIVISION</b>	
PROJECT		TYPICAL THERMAL POWER PROJECT	
TITLE		INTERFACING OF FIELD INSTRUMENTS INTERFACE OF DDCMIS WITH MCC/SWGR/ACTUATOR (Elect. Bkr. - Non. Sync.-LT)	
REV. NO.	DESCRIPTION	DATE	REV. NO.
B	Revised for Numerical Relay based SWGR.	14.02.08	B
REV. NO.	DESCRIPTION	DRAWN	DESIGN
		CHKD.	M
		C	C&I
		ARCH.	APPD
		DATE	DATE
SIZE	SCALE	DRG. NO.	REV. NO.
A3	NTS	0000-405-POI-A-065	B
SH 12 OF 14			

This document is the property of NATIONAL THERMAL POWER CORPORATION LTD. No part of this document will be reproduced by any means without the written permission.

MARSH./TERM CUBICLE 4 PAIR 0.5 Sq. mm

MCC/SWGR D-

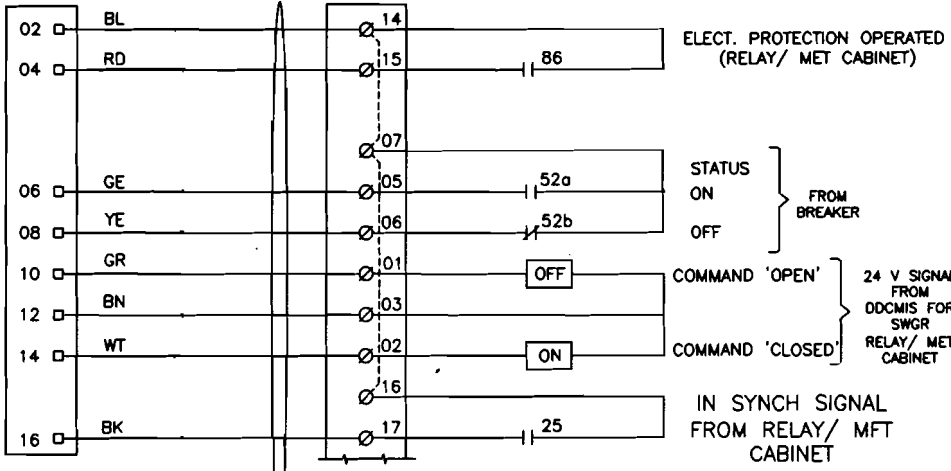

MCC/SWGR D-

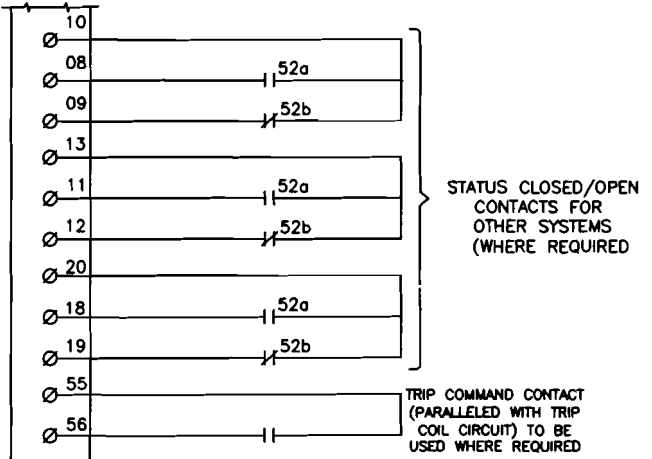

SHIELD BUS

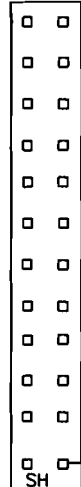

NOTE:-

1. SPARE CORES AT MCC/SWGR END ARE TO BE TERMINATED AT SPARE TERMINALS.
2. RELAY FAULT ALONG WITH OTHER INFORMATION SHALL FLOW THROUGH SOFT LINK.

FOR TENDER PURPOSE ONLY

**एन टी पी सी लिमिटेड**  
**NTPC LIMITED**  
 ( A GOVERNMENT OF INDIA ENTERPRISE )  
**ENGINEERING DIVISION**

PROJECT										TYPICAL THERMAL POWER PROJECT				
TITLE										INTERFACING OF FIELD INSTRUMENTS INTERFACE OF DDCMIS WITH MCC/SWGR/ACTUATOR (Elect. Brkr. - Sync.-HT)				
REV. NO.	DESCRIPTION	DRAWN	DESIGN	CHKD.	M	C	C&d	ARCH.	APPD	DATE	SIZE	SCALE	DRG. NO.	REV. NO.
B	Revised for Numerical relay based SWGR									14.02.08	A3	NTS	0000-405-POI-A-065	B
CLEARED BY										SH 13 OF 14				





Technical specification for  
**CONTROL & INSTRUMENTATION**  
2 X 800 MW DARLIPALI TPP, ODISHA

SECTION D	
REV. NO. 00	DATE : 04.06.2015

# LCP SPECIFICATION



## SPECIFICATION FOR LOCAL PANELS

SPECIFICATION NO.: PE-SS -999- 145 -054A

VOLUME II B

SECTION D

REV. NO. 03

DATE : 16-09-2013

SHEET 1 OF 6

### 1.0 SCOPE

This specification covers the Design, Manufacture, Inspection and Testing at the manufacturer's works, proper packing for transportation and delivery to site, **supervision, erection, and commissioning at site** of Local Panels required for control and monitoring of the Auxiliary Plant & Equipment.

### 2.0 CODES AND STANDARDS

2.1 All the equipments specified herein shall comply with the requirements of the latest issue of the relevant National and International standards.

2.2 As a minimum requirement, the following standards shall be complied with:

- a) IS-6005 : 1998 : Code of practice for phosphating of iron and steel.
- b) IS-5 : 2007 : Colors for ready mixed paints and enamels.
- c) IS-1248:2003 : Direct Acting Indicating Analog Elec Measuring Instruments.
- d) IS/IEC 60947:Part 1:2004 : Low Voltage switchgear & control gear: Part-I (General Rules)
- e) IS-8828:1996 : Circuit breaker for household and similar installations.
- f) IS-13947 (Part-I):1993 : Low Voltage switchgear & control gear : Part-I (General Rules)
- g) ISA-18.1:1979 : Annunciator Sequences and Specification
- h) NFPA-496:2003 : Purged & Pressurised Enclosure for Electrical Equipment in Hazardous Locations.

### 3.0 TECHNICAL REQUIREMENTS

3.1 Panel Construction

3.1.1 The local panels shall house the secondary instruments, annunciation system, Single loop controller, Control switches / push buttons, indicating lamps/**LED cluster**, relays, timers and other devices required for operation and monitoring of the equipment locally.

3.1.2 The panels shall be of free standing type either welded construction on angle iron (minimum section of 50 x 50 x 4 mm) structure or folded construction by sheet metal formation depending upon the equipments to be mounted on it. The panels shall be robustly built and **stiffeners** as necessary shall be provided.

3.1.3 The panel shall be suitably reinforced to ensure adequate support for all instruments mounted thereon. All welds on exposed panel surfaces shall be ground smooth.

3.1.4 **The salient features of construction shall be:**

**Sheet material: Cold rolled sheet steel**

**Frame thickness: Not less than 3.0mm**

**Enclosure thickness: Not less than 2.5 mm for load bearing sections (Mounted with instruments)  
1.6 mm for doors and Not less than 2.0 mm for others**

**Panel Height: Not less than 2365 mm (Refer data sheet-A (No. PES-145A-DS1-0)**

**Gland plate thickness: 3.0mm**

**Base channel: ISMC 100 with anti-vibration mounting & foundation bolts.**

3.1.5 The panel shall be provided with rear doors with integral lockable handle. The door when locked shall be held at minimum three places. The door width shall not be more than 550mm. The doors shall be provided with suitable **stiffeners** to prevent buckling. The handle shall be on the right side of the door. The door shall be removable type with concealed hinges to facilitate maintenance work. Suitable pocket inside the door shall be provided for keeping the drawings / documents. **Double door shall be provided with suitable glass windows, as per the requirement.**

3.1.6 Suitable neoprene gasket shall be provided on all doors and removable covers. Suitable ventilation **system along with louvers** shall be provided at bottom and top of the doors covered with removable wire mesh.



## SPECIFICATION FOR LOCAL PANELS

SPECIFICATION NO.: PE-SS -999- 145 -054A

VOLUME II B

SECTION D

REV. NO. 03

DATE : 16-09-2013

SHEET 2 OF 6

- 3.1.7 The class of protection shall be in accordance with IP-42 unless otherwise specified in the data sheet – A (No. PES-145-54A-DS1-0).
- 3.1.8 All steel surfaces shall be cleaned by sand / pellet blasting, treated for pickling, degreasing and phosphating etc. by seven tank method. The panel shall have a high quality finish and appearance. The panel shall be painted with two coats of primer followed by two coats of epoxy / synthetic enamel based final paint of color shade and finish as given in data sheet-A (No. PES-145A-DS1-0). Minimum thickness of the paint shall be 85 microns for external paint and 70 microns for internal paint.
- 3.1.9 The cable glands of the required size and type as given in data sheet-A (No. PES-145A-DS1-0) shall be supplied alongwith the Panel.
- 3.1.10 All operable and indicating devices shall be mounted on the front of the panel while aux. Relays / timers MCBs etc. required for realization of control logics shall be mounted on a mounting plate inside the panel. Auxiliary relays and timers etc. shall be grouped according to the control function. No operable or indicating devices shall be mounted below 750 mm and above 1800 mm (w.r.t. finished ground level). The devices shall be located in such a way so as to ensure easy access for operation / maintenance.
- 3.1.11 Single / dual control power supply feeders of voltage class as specified in data sheet-A (No. PES-145A-DS1-0) shall be provided by the purchaser. In case redundant power supply feeders are provided then auto changeover unit shall be mounted on the panel are in the panel supplier's scope. Where DC control power supply is specified an additional 240V, 50 Hz AC supply feeder for powering of space heater and lighting shall be provided by the purchaser. Suitable arrangement shall be provided inside the panel to receive and terminate the power supply feeder(s). For this purpose MCBs of suitable current rating shall be provided by the vendor. A supervisory relay along with a pilot lamp to indicate control supply 'ON' shall be provided on the panel. Any other power supply required for the operation of the devices mounted in the panel shall be arranged by the vendor.
- 3.1.12 The internal wiring shall be carried out with 1100 volt grade PVC insulated copper multi strand wire / flexible of 1.5mm<sup>2</sup> size. AC & DC wires shall be kept separate from each other. Separate coloured wires to be used for AC and DC circuits. All wires shall be properly numbered and identified with ferrules as per the Control scheme / wiring diagram. Wires shall be routed and run through PVC troughs.
- 3.1.13 Terminal blocks shall be clip on type, 1100 volts grade. Separate terminal blocks shall be used for AC & DC circuits. The terminals shall be suitable for terminating 0.5 mm<sup>2</sup> to 2.5mm<sup>2</sup> external cables. **The TB points in terminal block shall be cage clamp type / screw type.** The terminal for ammeters shall be provided with removable links for shorting CTs. Each terminal strip shall be provided with identification strip. The terminal shall not be mounted below 250 mm **height from finished floor. The panel shall have ten (20) percent spare terminal.**
- 3.1.14 The interior of each panel shall be suitably illuminated through fluorescent **lamps / tube lights with shrouded cover of minimum 15W** operable on 240V 50 Hz AC power supply through panel door switch. A 15 Amp. 3-pin Power receptacle shall be provided.
- 3.1.15 Suitable space heaters operable on 240 Volts 50 Hz AC power system shall be provided at the panel bottom. These shall be designed to maintain the panel temperature five (5) deg. C above the ambient temperature during maintenance shutdown. Suitable isolating and control devices comprising of MCB, thermostat etc. shall be provided for the space heater.
- 3.1.16 The panel shall be provided with a copper earth bus of 25 x 6 mm size running throughout the width of the panel. It shall be terminated internally with 10 mm bolts at extreme ends for connection to; main station earth. The panel mounted equipments / devices shall be connected to earth bus through green coloured PVC insulated stranded copper conductor of 2.5 mm<sup>2</sup> size.
- 3.1.17 Local Panel shall be provided with main name plate of 150 mm x 40 mm size having inscription of 20 mm height. The individual devices on the panels shall be as provided with separate name plate with inscription of 3 mm height. The instrument / devices shall be provided with stick on label plates inside the panel. The material of the main and individual labels shall be three (3) ply 3 mm thick Traffolyte



## SPECIFICATION FOR LOCAL PANELS

SPECIFICATION NO.: PE-SS -999- 145 -054A

VOLUME II B

SECTION D

REV. NO. 03

DATE : 16-09-2013

SHEET 3 OF 6

Sheet / 2 mm Anodised Aluminium Plate. The inscription shall be with white letters on black background on traffolyte sheet. The labels shall be fixed by self tapping non-rusting screws.

3.1.18 Vendor shall furnish electric load and heat load list ( in case panel is to be placed in ac environment ) of each panel.

### 3.2 Hazardous Area Panel Requirement

3.2.1 The Local Panel located in hazardous area shall be pressurized as per NFPA-496 requirements to render it non-hazardous. Alarms shall be provided for local and remote annunciation when pressurisation falls below 2.5 mm of water column. Protection shall be of type Z of NFPA-496. It shall not be possible to switch ON the power of purged section unless it is purged as per the recommendation of NFPA-496. Vendor must provide a protective device on the panel to protect the panel from over pressurisation.

3.2.2 Vendor shall supply pressurisation kit consisting of valves, restriction orifices, dual filter regulation, pressure gauges, pressure switches, rotameter etc. Pressurisation kit shall be surface mounting on a metal board and located outside the local panel. Pressurisation kit shall further consist of solenoid valve flow switch, timer blow off safety device etc., so as to make purging fully automatic. However final start shall be manual. Panel protection against over pressure to be provided as per NFPA-496.

3.2.3 Pressurised local control panel pressurization kit assembly design shall provide minimum leakage flow through the Local Control Panel. Panel venting shall be as per NFPA-496.

3.2.4 All components in the local panel like indicating instruments, push buttons switches, lamps etc., which are required to be energized without panel pressurization or before completion of purge cycle shall be explosion proof as per NEMA-7 & suitable for area classification.

3.2.5 All push buttons etc. requiring frequent operation during machine running shall have good positive sealing. Weatherproof housing or cover to be provided wherever necessary. Vendor shall provide pressurisation bypass switch outside explosion proof enclosure of pressurized panel with lamp indication. This shall be used only during maintenance. All hinges, screws, other non-painted metallic parts shall be of stainless steel material.

3.2.6 Provision to switch off manually all types of power shall be provided in the panel. In addition, it shall also be possible to switch off power circuits / components which are powered from motor control centre or control room manually in case of pressurization failure. All such cables from MCC and main control room shall be terminated in explosion proof boxes (NEMA-7).

### 3.3 Control & Monitoring devices

3.3.1 Instruments like Indicators, recorders, single loop controllers etc. as applicable and specified elsewhere for the plant / equipment shall be supplied and mounted on the panel.

#### 3.3.2 Alarm Annunciator System

It shall be solid state discrete facia type having a sequence of ISA-S18.1A or as specified, opaque facia windows of 70 mm x 50 mm size, having two (2) lamps per window, and hooter of 10W, and provision for repeat group alarm at remote. The annunciator shall be provided with ten (10) percent spare windows or minimum two (2) windows along with electronics.

#### 3.3.3 Relays

The relays shall be electromagnetic type suitable for specified control supply. Its contact configuration and rating shall be suitable for the specified control function. However minimum contact rating shall be 5 Amp AC & 2 Amp DC as applicable. There shall be ten (10) percent spare contacts.

#### 3.3.4 Timers

The timers shall be electronic type suitable for specified control supply. Its contact configuration and rating shall be suitable for the specified control function. However, minimum contact rating shall be 5 Amp AC & 2 Amp DC as applicable.



## SPECIFICATION FOR LOCAL PANELS

SPECIFICATION NO.: PE-SS -999- 145 -054A

VOLUME II B

SECTION D

REV. NO. 03

DATE : 16-09-2013

SHEET 4 OF 6

### 3.3.5 Control / Selector Switches

Switches shall be Rotary Cam type with minimum of 5 Amps AC & 2 Amp DC continuous current rating. Selector switches shall be stay put type while control switches shall be spring-return-to-neutral type. Contact configuration and rating shall be as per the control function requirement. The switches shall be lockable type wherever specified. Each switch shall be provided with engraved plates indicating the switch position / functions.

### 3.3.6 Push Buttons / Indicating Lights

The push buttons shall be momentary action self-resetting type, however stop P.B. for unidirectional drives shall be provided with manual reset facility. Its contact configuration & rating shall be as required for the control function but minimum 2 NO + 2 NC of 5 Amp. AC rating. It shall have round coloured projecting tab and engraved escutcheon plate / inscription plate. Colour coding of push buttons shall be as under:

RED	Motor OFF / Valve CLOSE	YELLOW	Alarm acknowledge	Left Hand Side
GREEN	Motor ON / Valve OPEN	BLACK	Lamp test	Right Hand Side

Indicating lights shall be suitable for direct connections across specified power supplies. It shall be fitted with built in resistance to prevent circuit tripping on shorting of lamp filament. It shall be fitted with LED cluster type lamp replaceable from front.

GREEN	Motor OFF / Valve CLOSED condition	AMBER	Motor tripped	Left Hand Side
RED	Motor ON / Valve OPEN condition	WHITE	Normal / healthy	Right Hand Side

### 3.3.7 Ammeters

Ammeter shall be 96 x 96 mm size, 90 deg. deflection, 1.5% accuracy, 1 Amp. CT operated or with 4-20mA input and Flush mounting type as called for in the data sheet-A (No. PES-145-54A-DS1-0). Ammeters for motors shall have six (6) times folded scale at upper end to enable motor starting current indication

### 3.3.8 Miniature Circuit Breaker (MCB)

These shall be instantaneous magnetic trip type for short circuit in addition to current time inverse delayed thermal trip feature for over current protection. The housing of MCB shall be made of non-ignitable, high impact material. It shall have minimum short circuit rating of 9 KA for AC Voltages and 4 KA for DC Voltages.

### 3.3.9 Makes of various instruments / devices shall be as given below

1.	Alarm Annunciators	:	Procon / IIC
2.	Ammeters	:	AEP / IMP
3.	Control / Selector Switches	:	Alsthom / Kaycee / Siemens / L&T
4.	Push Buttons / Indicating Lamps	:	Siemens / L&T / Teknic / Alsthom
5.	Auxiliary Relays	:	Jyoti / Siemens / L&T / OEN
6.	Timers	:	L&T / Alsthom / Bhartiya Cutler Hammer
7.	MCBs	:	S&S Power Engg. / Indo Asian / MDS
8.	Terminal Blocks	:	Jyoti / Elmex

## 4.0 TESTING AND INSPECTION

4.1 The bidder shall adopt suitable quality assurance program to ensure that the equipments offered will meet the specification requirements in full.

4.2 BHEL's standard Quality Plan for LCP is enclosed with the specification. The bidder shall furnish his acceptance to BHEL's QP and submit the signed and stamped copy of QP along with the offer.



## SPECIFICATION FOR LOCAL PANELS

SPECIFICATION NO.: PE-SS -999- 145 -054A

VOLUME II B

SECTION D

REV. NO. 03

DATE : 16-09-2013

SHEET 5 OF 6

4.3 The vendor shall conduct the following tests as a minimum requirement:

4.3.1 Routine Tests

1. High Voltage (H.V.)
2. Insulation Resistance (I.R.)
3. Functional

4.3.2 Type Tests

1. Enclosure Class Test



## SPECIFICATION FOR LOCAL PANELS

SPECIFICATION NO.: PE-SS -999- 145 -054A

VOLUME II B

SECTION D

REV. NO. 03

DATE : 16-09-2013

SHEET 6 OF 6

### 5.0 SPARES AND CONSUMABLES

#### 5.1 Commissioning Spares and consumables

The bidder shall supply all commissioning spares and consumables 'as required' during Start-up, as part of the main equipment supply.

#### 5.2. Mandatory Spares

The bidder shall offer alongwith main offer, the Mandatory Spares as specified elsewhere in the specification. The Mandatory Spares offered shall be of the same make and type as the main equipment.

#### 5.3. Recommended Spares

The bidder shall furnish a list of Recommended Spares indicating the normal service expectancy period and frequency of replacement; quantities recommended for 3 years operation alongwith unit rate against each item to enable BHEL/BHEL's Customer to place a separate order later, if required.

### 6.0 DRAWINGS AND DOCUMENTS

#### 6.1 The bidder shall furnish the following documents in required number of copies along with the bid :

1. Data Sheet no. PES-145A-DS1-0
2. General Arrangement Drawing.
3. Catalogue and technical information for instruments and devices.
4. Quality Plan.

#### 6.2 The vendor shall furnish the following documents in required number as agreed after the award of contract:

1. Data Shee No. PES-145A-DS2-0
2. GA Drawing indicating layout of instruments, construction details, foundation details, cable gland plate alongwith cable glands and all details mentioned in this specification.
3. Control Schematic Diagram along with grouping of different terminals for various functions.
4. Catalogue and technical information for instruments and devices with selected options clearly marked.
5. O&M Manuals.
6. "As Built" Drawing.
7. CDs.

### 7.0 MARKING AND PACKING

#### 7.1 Panel with all instruments / devices mounted on it shall be suitably packed & protected for the entire period of despatch, storage and erection against impact, abrasion, corrosion, incidental damage due to vermin, sunlight, high temperature, rain moisture, humidity, dust, sea-water spray (where applicable) as well as rough handling and delays in Transit and storage in open.

### 8.0 APPLICABLE DATA SHEET FORMS

This document shall be read with one or more of the following data sheet forms :

- |                                   |   |                               |
|-----------------------------------|---|-------------------------------|
| - Data sheet A&B for Local Panels | : | Data sheet no. PES-145A-DS1-0 |
| - Data sheet C for Local Panels   | : | Data sheet no. PES-145A-DS2-0 |



## DATA SHEET FOR LOCAL PANELS

SPECIFICATION NO.: PE-SS-999-145-054A

VOLUME

SECTION

REV. NO. 02

DATE: 10.02.2015

SHEET 1

OF 3

TAG No. .... Qty.....

Data Sheet No.: PES-145A-DS1-0

### Data Sheet A & B

DATA SHEET-A FOR LOCAL PANEL  
(TO BE FILLED BY PURCHASER)

DATA SHEET-B  
(TO BE FILLED-UP BY  
BIDDER)

GENERAL	MANUFACTURER	
	CONSTRUCTION	<input checked="" type="checkbox"/> FOLDED <input type="checkbox"/> WELDED (As per requirement EDN)
	ENCLOSURE SHEET THICKNESS	FRONT <input checked="" type="checkbox"/> 2.0 mm
		OTHER <input checked="" type="checkbox"/> 2.0 mm
		DOOR <input checked="" type="checkbox"/> 1.6 mm
		HEIGHT <input checked="" type="checkbox"/> 2365 mm for stand alone panels. <input type="checkbox"/> Other .....
		OTHER <input checked="" type="checkbox"/> Load bearing sheet front shall have 3mm thickness
TECHNICAL	INPUT POWER SUPPLY *	<input type="checkbox"/> 240V 50 Hz AC <input type="checkbox"/> 220V DC <input type="checkbox"/> 415V 3 PHASE 3W <input checked="" type="checkbox"/> 415V 3 PHASE 4W (ANY OTHER POWER REQUIREMENT TO BE DERIVED FROM THIS SUPPLY ONLY)
	NO. OF FEEDERS	<input type="checkbox"/> ONE <input checked="" type="checkbox"/> TWO
	STARTER WITH MCC (CHECK WITH MAUX/ELEC)	<input type="checkbox"/> REQUIRED <input checked="" type="checkbox"/> NOT REQUIRED
	IPR POSITION	<input checked="" type="checkbox"/> MCC <input type="checkbox"/> RELAY PANEL
	CONTACT RATING OF RELAY	<input checked="" type="checkbox"/> 5 Amp, 230 V AC <input type="checkbox"/> 0.25 Amp, 220V DC
	CONTROL SUPPLY	<input type="checkbox"/> 110V AC <input type="checkbox"/> 220V AC <input type="checkbox"/> 220V DC <input type="checkbox"/> Other. <input checked="" type="checkbox"/> (As per requirement)
	ALARM ANNUNCIATOR WINDOW (EXCLUDING SPARES)	__During Detailed Engineering__ NOS. (AS REQUIRED)
	TEMP SCANNER (IF REQUIRED –NO. OF CHANNELS TO BE SPECIFIED UNDER SEC-C )	<input type="checkbox"/> REQUIRED <input checked="" type="checkbox"/> NOT REQUIRED
	PAINT TYPE	<input type="checkbox"/> EPOXY ENAMEL <input checked="" type="checkbox"/> EPOXY POWDER COATED
	MIMIC (TYPE OF MIMIC- MATERAIL, THICKNESS TO BE SPECIFIED DURING DETAILED ENGG. )	<input type="checkbox"/> REQUIRED <input checked="" type="checkbox"/> NOT REQUIRED
	PANEL COLOUR (EXTERNAL)	<input checked="" type="checkbox"/> LIGHT GREY (Shade 631 IS-5) <input type="checkbox"/> OPALINE GREEN (Shade 275)
	FINISH (EXTERNAL)	<input type="checkbox"/> MATT <input checked="" type="checkbox"/> GLOSSY <input type="checkbox"/> SEMI GLOSSY
	PANEL COLOUR (INTERNAL)	<input checked="" type="checkbox"/> WHITE <input type="checkbox"/> CREAM <input type="checkbox"/> OFF WHITE
	FINISH (INTERNAL)	<input type="checkbox"/> MATT <input checked="" type="checkbox"/> GLOSSY <input type="checkbox"/> SEMI GLOSSY
	CLASS OF PROTECTION	<input type="checkbox"/> IP-42 (FOR INDOOR SERVICE) <input checked="" type="checkbox"/> IP-55 (FOR OUTDOOR SERVICE) <input type="checkbox"/> ANY OTHER
	CONTROL HARDWARE	<input type="checkbox"/> RELAY BASED



**DATA SHEET FOR LOCAL PANELS**

SPECIFICATION NO.: PE-SS-999-145-054A	
VOLUME	
SECTION	
REV. NO. 02	DATE: 10.02.2015
SHEET 2	OF 3

TAG No. .... Qty.....

Data Sheet No.: **PES-145A-DS1-0**

**Data Sheet A & B**

DATA SHEET-A FOR LOCAL PANEL  
(TO BE FILLED BY PURCHASER)

DATA SHEET-B  
(TO BE FILLED-UP BY  
BIDDER)

FOUNDATION ARRANGEMENT	<input type="checkbox"/> FOUNDATION BOLTS <input type="checkbox"/> ANCHOR FASTENERS <input checked="" type="checkbox"/> SKID MOUNTED	
WEIGHT OF PANEL (Kg.)	.....(Vendor to specify )	
PANEL TYPE	<input type="checkbox"/> PRESSURISED <input checked="" type="checkbox"/> UNPRESSURISED As per Requirement	
CABLE GLAND	<input checked="" type="checkbox"/> DOUBLE COMPRESSION	
AMMETER (TYPE OF INPUT) *	<input type="checkbox"/> 1 Amp CT <input type="checkbox"/> 4-20 mA	
SCOPE OF SUPERVISION FOR ERECTION & COMMISSIONING	<input type="checkbox"/> APPLICABLE <input checked="" type="checkbox"/> NA	

\* TO BE CO-ORDINATED WITH PEM ELECTRICAL

NAME DESIGNATION  SIGNATURE  DATE	<b>PREPARED BY</b>	<b>CHECKED BY</b>	<b>APPROVED BY</b>	COMPANY SEAL  NAME:  SIGNATURE:  DATE:



**DATA SHEET FOR LOCAL PANELS**

SPECIFICATION NO.: PE-SS-999-145-054A

VOLUME

SECTION

REV. NO.

02

DATE: 16.09.2013

SHEET

3

OF

3

TAG No. .... Qty.....

Data Sheet No.: **PES-145A-DS1-0**

**Data Sheet C**

DATA SHEET-C FOR LOCAL PANEL  
(TO BE FILLED BY CONTRACTOR AFTER AWARD OF CONTRACT)

<b>GENERAL</b>	MANUFACTURER		
	CONSTRUCTION		<input type="checkbox"/> FOLDED <input type="checkbox"/> WELDED (As per requirement EDN)
	ENCLOSURE SHEET THICKNESS	FRONT	
		OTHER	
		DOOR	
		HEIGHT	
OTHER			
<b>TECHNICAL</b>	INPUT POWER SUPPLY		
	NO. OF FEEDERS		
	CONTACT RATING OF RELAY		
	TEMP SCANNER		
	CONTROL SUPPLY		
	ALARM ANNUNCIATOR WINDOW (EXCLUDING SPARES)		
	PAINT TYPE		
	PANEL COLOUR (EXTERNAL)		
	FINISH (EXTERNAL)		
	TYPE OF MIMIC		
	MATERIAL OF MIMIC		
	THICKNESS OF MIMIC		
	PANEL COLOUR (INTERNAL)		
	FINISH (INTERNAL)		
	CLASS OF PROTECTION		
	CONTROL HARDWARE		
	FOUNDATION ARRANGEMENT		
WEIGHT OF PANEL (Kg.)			



**DATA SHEET FOR LOCAL PANELS**

SPECIFICATION NO.: PE-SS-999-145-054A

VOLUME

SECTION

REV. NO. 02

DATE: 16.09.2013

SHEET 3 OF 3

TAG No. .... Qty.....

Data Sheet No.: **PES-145A-DS1-0**

**Data Sheet C**

DATA SHEET-C FOR LOCAL PANEL  
(TO BE FILLED BY CONTRACTOR AFTER AWARD OF CONTRACT)

	PANEL TYPE			
	CABLE GLAND			
	AMMETER (TYPE OF INPUT)			
	SCOPE OF SUPERVISION			
NAME SIGNATURE DATE	PREPARED BY	CHECKED BY	APPROVED BY	COMPANY SEAL NAME: SIGNATURE: DATE:



Technical specification for  
**CONTROL & INSTRUMENTATION**  
2 X 800 MW DARLIPALI TPP, ODISHA

SECTION D

REV. NO. 00

DATE : 04.06.2015

# LCP Quality Plan