

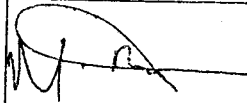

\*\*\*\*\*

TITLE : TECHNICAL SPECIFICATION FOR BOUGHT OUT ITEMS FOR ESP  
 ITEM : ELECTRONIC CONTROLLER PANEL & HIGH VOLTAGE RECTIFIER TRANSFORMER (EC-HVR)  
 PROJECT : BHEL STANDARD

NAME		DESIGNATION	SIGNATURE	DATE
PREPARED	M. BOOPATHY	EF		07.12.2004
CHECKED	C.R.JAYACHANDRAN	SR.MGR		07.12.2004
APPROVED	C.R.JAYACHANDRAN	SR.MGR		07.12.2004

ISSUED BY  
 EDC - AQCS

\*\*\*\*\*

## 1.0.0 SCOPE

1.1.0 The high voltage DC Power supply equipment having High voltage transformer rectifiers (HVR) and Electronic controller Panel (EC) shall be supplied complete with all fittings and accessories as detailed in specification and as required to make the system complete. The scope also included commissioning of EC – HVR at site.

1.2.0 BHEL / BAP / Ranipet will supply microprocessor based TR set controller (BAPCON) along with the following accessories directly to site, for mounting and wiring in the Electronic control panel. However necessary fixing provision, termination provision and wiring provision for Firing card shall be provided by supplier and suitable fixing clamps shall be provided for interconnecting cable support.

- a) Microprocessor based controller.
- b) Firing (Triggering) card.
- c) 1.8 m length screened connecting with disconnecting type plug in connector at both ends.

1.3.0 One set of typical microprocessor based controller shall be collected from BHEL / BAP / Ranipet on returnable basis at the time of Routine / type test as applicable and the same shall be duly returned to BHEL / BAP / Ranipet immediately on completion of such tests.

1.4.0 The HVR and EC shall be suitable Electrostatic Precipitator (ESP) application. It is the responsibility of the bidder to know all aspects of ESP, which decides the design & performance of the HVR & EC.

## 2.0.0 PROJECT INFORMATION :

2.1.0 Ambient conditions :

2.1.1 Ambient temperature 1°C to 50°C.

2.1.2 Humidity Upto 100%.

2.2.0 Location :

2.2.1 High voltage transformer  
Rectifier unit Outdoor, on top of ESP.

2.2.2 Electronic controller Indoor.

2.3.0 Quantity As per enquiry.

2.4.0 Environment The atmosphere will be very dusty and of very high abrasive nature. The equipment shall be suitably tropicalized, designed and manufactured for such environment.

## 3.0.0 APPLICABLE STANDARDS:

### 3.1.0 GENERAL

The equipment shall be designed, manufactured and tested as per applicable standards listed below and as per this technical specification.

\*\*\*\*\*

If there is any contradiction between the specification and standards, the specification shall apply. If there is any contradiction between standards listed or between various clauses, the most onerous condition shall apply. Further to above, the panels & transformer shall meet local statutory regulation as applicable.

### 3.2.0 STANDARDS:

IS 5, IS 5578, IS 11353, IS 694, IS 1248, IS 3947, IS 2026, DIN 57146, IS 9924, IS 3043, IS 4064, IS 4237, IS 6875, IS 9000

### 4.0.0 TERMINAL CONDITIONS :

- |   |   |
|---|---|
| 4.1.1 Power supply available  | 415V, 1Phase, 2 Wire, 50HZ AC ( In case any other power source is indicated, the same shall be complied with) |
| 4.1.2 Power supply variation  |   |
| 4.1.2.1 Voltage.  | + / - 10%.  |
| 4.1.2.2 Frequency.  | + / - 5%.   |
| 4.1.2.3 Combined variation of Voltage & Frequency                       | 10% (Absolute sum).   |
| 4.2.1. Rated output voltage and out put current will be as per Enquiry. |   |
| 4.2.2 Capacitance of precipitator (PF)                                  | 200 X rated output ct. (mA).  |
| 4.2.3 Form factor to be considered for HVR                              | : 1.4 max. for input current and 1.15 for input voltage.  |
| 4.3.1 Output terminal   | : Through single horizontal terminal.   |

### 5.0.0 FUCNTION

The Transformer Rectifier unit along with the Electronic Controller with Microprocessor based controller is meant as automatic constant current source of power to the Electrostatic Precipitator.

### 6.0.0 DESIGN & OPERATIONAL REQUIREMENTS :

- 6.1.0 The HVR unit along with its Electronic controller is meant as a source of DC supply for ESP. The unit shall be thyristor controlled type suitable for 24 hours a day operation continuously, with frequent sparking in the precipitator load, occasionally having 200 sparks per minute. The basic mode of operation of the rectifier shall be constant current regulation.
- 6.2.0 The EC – HVR, fitted with the BHEL supplied microprocessor based TR set controller (BAPCON) , shall regulate the output current to the set value within + / - 5 % for any non sparking load conditions between 0 to 100% of the rated output current for any / all of the following conditions :

\*\*\*\*\*

1. Variation in impedance of EP load.
  2. Variation in EC – Panel input voltage between  $415 + 10 \%$  to  $415 - 10 \%$ . The HVR shall deliver the rated secondary voltage and current with load connected, when the transformer primary voltage is 373.5 V.
- 6.3.0 It shall be noted that the precipitator is a dead load, the electrodes inside the Precipitator keep swinging slightly with frequency of 5 to 10 HZ. Under certain conditions, the precipitator may act like a tuned – circuit, since the precipitator can be regarded as a capacitive load. A critically adjusted controller may be completely stable when connected to a resistive load but not necessarily when connected to a Precipitator load, such regulator instability will not be accepted. The unit shall be capable of operating at any secondary current provided the primary current is not exceeded. The unit shall be capable of operating under accidental no load, which may occur during startup, maintenance and operation, without damage. The unit may be subjected to short circuit condition when the ESP Electrodes gets snapped during operation. The EC –HVR unit shall be suitable for the above condition.
- 6.4.0 The EC & HVR, in association with BAPCON, the Microprocessor based TR set controller, shall regulate and control the electric power input to the Electrostatic Precipitators. The EC & HVR shall maintain the spark rate at a set level for great variations of gas temperature, dust composition, gas flow etc. The EC & HVR shall regulate the thyristor in such a way, that current through Electrostatic Precipitator is corrected as the conditions for sparking are changed.
- 6.5.0 The EC –HVR to be supplied shall be field proven type and shall be type tested type.
- 7.0.0 BHEL MAKE MICROPROCESSOR BASED TR SET CONTROLLER:
- The EC & HVR shall be completely suitable for BHEL make microprocessor based TR set controller (BAPCON). The bidder is advised to know the necessary details about BHEL make microprocessor based controller (BAPCON), so that the EC& HVR can be designed to suit BHEL make microprocessor based controller (BAPCON).
- 8.0.0 CONSTRUCTIONAL & DESIGN FEATURES OF TRANSFORMER RECTIFIER :
- 8.1.0 The high voltage transformer rectifier shall be as per IS 2026 & DIN 57146. the transformer rectifier shall be suitable for operation with Microprocessor based TR set controller with charge ratio 1 : 1 to 1 : 159 and base charge range of 0 – 49 % of set current. The controller will limit current peaks to 204 % under intermittent charging mode .
- 8.2.0 The HV transformer rectifier shall consist of suitably rated single phase high voltage step-up transformer, the secondary of which is connected to a full wave bridge connected rectifier. The transformer windings, magnetic circuit and other associated components and rectifier stack shall be housed in a common transformer tank made of robust, leak proof welded steel structure, rectangular in shape and shall have “ON” type cooling. The transformer shall be filled with mineral oil as per IS 335 or silicon oil as per the enquiry / purchase order. Suitably sized CONSERVATOR shall be provided to take care of the oil expansion due to the operating conditions & ambient conditions. Access shall be provided to the internals for convenience and

\*\*\*\*\*

ease of maintenance and repairs. The wheels of HVR shall be separated at a distance of 900 mm (along the Bushing) and at a distance of 550 mm (across the Bushing ). The wheels shall have approximate thickness of 50 mm. The distance between Bushing center line and the wheel bottom shall be 700 mm. Other dimensions of the transformer shall be decided by the vendor to suit the rating. The winding shall be of copper. The transformer shall be designed to meet all type acceptance and routine tests indicated in this specification and Quality plan referred in the enquiry / purchase order.

- 8.3.0 Following accessories and fittings shall be provided for the transformer in addition to those covered under IS 2026 Part – I.
- (i) Two float Buchholz relay with isolating valves on either side.
  - (ii) Dial thermometer with two sets of contacts. The sets of contacts shall have a setting difference of 5 to 10°C. the dial thermometer shall be housed in a weather proof box. The first set of contact shall be for alarm only and the other set of contact shall be for trip and alarm.
  - (iii) Thermometer pocket.
  - (iv) Magnetic oil level indicator (MOG) with marking to indicate the minimum level of oil. One set of contact shall be provided to interface with controller to trip under oil level low. Apart from MOG, prismatic oil type level indictor shall also be provided.
  - (v) Two numbers of filter valves. The bottom valve will be used for draining oil and shall have sampling port.
  - (vi) An explosion vent / Pressure Relief valve.
  - (vi) Bottom supporting frame with bolting arrangement castors, lifting lugs and bi directional wheels.
  - (vii) Danger plate – 2 Nos.
  - (viii) The HVR shall be provided with Double compression type nickel coated Brass cable Glands ( COMMET / BRACCO make) and Pre insulated Annealed Tinned Copper lugs (Dowells / Commet make) to receive the external cables. The quantity and size of Glands & Lugs will be indicated during drawing approval
- 8.4.0 The feedback DC current shunt shall be located outside the transformer tank. The shunt shall be enclosed in a weather proof box for external termination. A high voltage resistor column for measurement of DC output voltage shall be located in side the transformer tank. Measuring terminals shall be brought out for external termination. Necessary protections in the form of glow tube and voltage clamping devices shall be provided.
- 8.5.0 Power connections for LT supply shall be extended with adequate support such that power cables can be terminated vertically without bending the cable cores.
- 8.6.0 The positive lead of rectifier output shall be taken through an earth bushing. The earth bushing shall be located on the transformer tank. The negative terminal of the rectifier output shall be through side mounted high voltage busing insulator. This bushing shall be provided on the side wall of the transformer. The terminal side of the bushing shall have M10 threading.

\*\*\*\*\*

- 8.7.0 A suitable metallic duct enclosing the negative bushing shall be provided with flange for the protection of the Bushing Insulator against adverse condition such as rain and accumulation of dust.. This flange shall match the flange provided in the Disconnecting Switch (supplied by BHEL), The metallic duct shall have square flange of dimension 650 mm X 650 mm with 24 nos. 9.5 mm dia. holes, to connect the duct with purchaser's equipment. An opening to clean the insulator shall be provided in the duct.
- 8.8.0 There shall be two separate grounding terminals for +ve grounding of tank. The positive busing terminal shall be connected by tinned copper strips to the earth terminal, externally. The positive terminal shall also be earthed, internally within the TR set.
- 8.9.0 There shall be a Marshalling box mounted on the transformer. The Marshalling box shall house terminations for Bucholzs relay, dial type thermostat contacts. Heavy Duty brass double compression cable glands and pre insulated Annealed tinned Copper lugs shall be provided for terminating external power, control cable and screened cables.
- 8.10.0 The HVR shall be provided with Double compression type nickel coated Brass cable Glands and Pre insulated ATC lugs to receive the external cables. The quantity and size of Glands & Lugs will be indicated during drawing approval.
- 8.11.0 Interlocking type or colour coded ferrules of proper size shall be used for control and signal wiring.
- 8.12.0 Non conducting barrier shall be provided between LV and HV connection. Hylam is not accepted as barrier.
- 8.13.0 The rectifier shall be made of silicon diode stacks. The diodes shall have adequate safety factor and protections and shall be mounted on printed circuit / moulded discs.
- 8.14.0 A suitable linear reactor with adequate impedance to limit short circuit current 2.5 to 3 times rated current shall be located inside the tank. The reactor shall be designed to generate minimum vibration and noise.
- 8.15.0 A suitably rated Radio Frequency Choke shall be located inside the Transformer Tank to protect the HVR from the sparking that may occur in the ESP.
- 8.16.0 The HVR Transformer shall be provided with Danger Plate.
- 8.17.0 The HVR Transformer shall deliver the rated Secondary voltage & current with load connected, when the Transformer primary voltage is at 90% of the system voltage.
- 8.18.0 The HVR shall be designed to pass the Double voltage Double frequency testing.
- 8.19.0 SEALED OR HERMETICALLY TYPE TRANSFORMER:

Whenever, the Enquiry / Purchase Order calls for Sealed Type or Hermetically Sealed type HVR, then the HVR Transformer shall be provided with Expandable Fins at the HVR side walls to take care of oil expansion. In addition the HVR shall be provided with Oil Level switches,

\*\*\*\*\*

Pressure Relief valve, Dial Type Thermometer, Oil level Gauge, Pressure switch etc. CONSERVATOR and Bucholz Relay should not be provided in such cases. All other requirements are, as per the HVR Transformer with Conservator.

#### 9.0.0 ELECTRONIC CONTROLLER PANEL (EC):

- 9.1.0 The Electronic controller shall be suitable for operation with HV transformer rectifier unit and BHEL supplied BAPCON. It shall be dust and vermin proof, free standing floor mounted type-having opening from rear and front with enclosure meeting IP54 degree of protection Neoprene gaskets / natural rubber shall be provided for all metal-to-metal joints. The panel shall be suitable for continued trouble free operation in dusty atmosphere. The construction of panel shall be such that free access is possible to all components for eases of troubleshooting and maintenance.
- 9.2.0 The Electronic controller shall have provision of mounting BHEL supplied Microprocessor based TR set controller ( BAPCON) module on front door at a suitable operating height. Terminal blocks for interfacing of microprocessor based TR set controller & its Firing Card, shall be provided in the ELECTRONIC CONTROLLERS. The EC panel shall be provided with a cut-out of dimensions 255 x 180mm for mounting the BAPCON. The dimensions of BAPCON are 280 mm (W) X 200 mm (D) and 210 mm (H). The EC panel lay out shall be such that, the BAPCON shall not foul with any component. The General Arrangement of the EC panel., the components lay out inside the EC panels and the Electrical Scheme of EC & HVR are subjected to BHEL approval.
- 9.3.0 The panel shall be made of 2 mm thick steel sheet. (If higher thickness is asked in the Enquiry / Purchase order then higher thickness shall be provided). The panel doors shall be rigid enough to avoid wobbling. Cubicle light with door operated switches and 15A, 230V single phase 5 pin socket for soldering iron / blower supply shall be provided at the incoming supply terminal through a adequately rated transformer. The front door of cubicle shall be interlocked to ensure that the interior of panel can not be reached until the mains supply is made OFF.
- 9.4.0 Apart from this, cutouts as per the sketch indicated in the Annexure, for mounting a special rotary interlock, which shall be fitted by buyer, shall also be provided on cubicle front to de – energies the rectifier when the key of the special interlock is removed. This facility is intended for interlocking of the HV transformer rectifier with the Precipitator for safety of operating personnel and equipment. Necessary wiring and terminations shall be made to include the NC contact of this key interlock in the coil circuit of main contactor.
- 9.5.0 Supplier shall provide LED TYPE INDICATING LAMPS wherever applicable.
- 9.6.0 All controls and instrumentation shall be insensitive to vibration, dust & humidity and shall be fully tropicalized
- 9.7.0 Necessary foundation frames (min 75 mm height), bolts, nuts, washer etc shall be provided along with controller for installation. Ant vibration pads, where specified in the enquiry shall be provided. The total dimensions of the panel shall be 700 mm (W) X 650 mm (D) X 2000 mm (H). However if any specific dimension is as in the Enquiry /Purchase order, then the panel shall have the dimensions indicated in the Enquiry / Purchase order. In order to meet various criteria

\*\*\*\*\*

specified in this specification and if the manufacturer's design requires higher dimensions, then the panel shall have higher dimension to meet such requirements. The operating height shall be between 700 mm and 1800 mm . The height of the panel is subjected to the approval of BHEL, which is based on end user's requirement. There shall not be any commercial implications on account of such approvals.

9.8.0 The bus bar support shall be of moulded type, non – hygroscopic, anti – tracking and non – inflammable. The location of power terminals shall be above 270 mm from gland plate. Bus-bar shall be suitable to terminate four runs incoming power cables and 4 runs of out going power cable. All hardwires such as bolts, nuts and washers shall be nickel / cadmium plated / zinc passivated.

9.9.0 The Electronic controller shall house the following:

- a) Heavy duty load break Fuse switch unit with HRC fuse or MCCB, as per Enquiry / Purchase order ( of L&T / SIEMENS / ABB make)
- b) Thyristor units with rear mounted black insulating painted heat sinks along with necessary protections.
- c) Control and other auxiliary power circuit shall have double pole MCB (L&T/ SIEMENS make). Glass fuses are not acceptable.
- d) Audible alarm in the form of hooter to annunciate fault conditions.
- e) Visual indications for ON / OFF , ALARM & TRIP signals by LED lamps. (L&T / SIEMENS make)
- f) Accept pushbutton (of L&T / SIEMENS make) shall be provided for alarm. The accept pushbutton operation shall make the Hooter OFF, while lamps shall be kept glowing, unless the fault is rectified or removed. First fault shall be annunciated along with visual alarm while subsequent faults shall be annunciated even if previous fault is not cleared. However they shall be indicated by visual alarm.
- g) Resin cast current transformer for protection and metering.
- h) Auxiliary contactors as required. The contactors shall be of heavy duty. (L&T / SIEMENS make ). Relays are not acceptable. MOVs shall be provided across all contactors.
- i) Control supply transformer of adequate rating and class B insulation with primary tappings for + / - 10% shall be provided. For firing card 18 VAC power supply with primary tappings for + / - 1- % shall be provided.
- j) Double compression type nickel plated Brass cable glands ( COMMET / BRACCO make) and Pre insulated Annealed Tinned Copper Lugs (Dowells / Commet make), to terminate external cables, shall be provided in the EC panel. The quantity and size of Glands & Lugs will be indicated during drawing approval. The cable glands shall be fitted on removable gland plate of thickness of 3mm.
- k) Following connectors are to be provided with EC panel to interface BAPCON & FIRING CARD

BAPCON

Cable No	Phoenix Make	Male / Female
	Type reference	

\*\*\*\*\*

1 to 7	MSTBVK 2.5/7-G-5.08	F
8 TO 13	MSTBVK 2.5/7-G-5.08	F
18 - 19	MSTBVK 2.5/4-G-5.08	F
28 - 29	MSTBVK 2.5/4-G-5.08	F
20 - 23	MSTBVK 2.5/4-G-5.08	F
24 - 27	MSTBVK 2.5/4-G-5.08	F
14 - 17	MSTBVK 2.5/4-G-5.08	F

FIRING CARD

Connector	Phoenix Make Type reference	Male / Famale
J1 - J2	MVSTBW 2.5/ 2	M
J3 - J6	MVSTBW 2.5/ 4	M
J7 - J10	MVSTBW 2.5/ 4	M

- (l) Din rail EN50045 shall be provided for mounting terminals required for BAPCON interface.
- (m) Suitable DIN RAIL(EN50045) of length 220 mm, shall be provided to mount the Firing card. The details of FIRING CARD are indicated in the Annexure.
- (n) DIN rail shall comply with latest European standards and make up of steeling accordance with DIN - VDE 0611 part 3.
- (o) 5 digit time totalizer of Non Reset able type.

9.10.0 All internal wiring shall be neatly laid out. Ferrule numbering shall be adopted for wiring. Inter component wiring shall be done with extra flexible stranded copper conductor PVC insulated wires. More than two wires shall not be terminated in a terminal block. Each wire shall be provided with a separate lug for termination. Suitable pre - insulated ATC lugs and clip on type terminals shall be used in wiring. All power wiring shall be done with tinned copper bus bars of suitable size to withstand 50 KA for 1 Sec. For CT shorting link, ELMEX CATD or equivalent type shall be provided. All the wires shall be laid down through cable tray channel. For control and signal wiring, 1 sq mm copper PVC insulated wires to be used.

9.11.0 20% spare control terminal blocks shall be provided in the panel for each row / group of terminal. Terminal block of phenolic, polyetelene or hylum are not acceptable. It shall be made of melamine. The insulating material of epoxy or fibreglass shall be preferred. The current rating of terminal blocks shall be at least twice that of terminated wires.

9.12.0 The Earth Bus shall be provided with 9 nos. lugs to receive screening of external cables.

9.13.0 GROUNGING

A tinned copper ground bus of minimum 150 sq mm cross - section shall be run along the entire width of the panel. Two external grounding points with M12 bolts, nuts and washer for connecting purchaser's ground conductor (50 x 6 GI) shall be earthed to the ground bus separately. All ground points shall be connected to ground separately. Insulated ATC lugs to earth, screens of external screen cable shall be provided.

\*\*\*\*\*

9.14.0 MEASURING INSTRUMENTS :

Separate C.T's shall be provided for metering and protection. All instrument transformers required for metering shall be of class 1 accuracy and those for protection shall have class 5P3 accuracy. Adequate burden shall be provided for transformer. The indicating meters shall be of flush mounting type. The dial range shall be such that it shall read rated value at 75% deflection of indicator. Ammeter and current coil of meters shall continuously withstand 120% of rated current and 5 times rated current for 0.5 sec without loss of accuracy. Voltmeters and potential coils shall withstand 120% of rated voltage continuously and twice the rated voltage for 0.5 sec.

Instrument dial shall be white with black numerals and lettering. Knife-edge pointers are preferred. There shall be red mark on dial corresponding to rated value. The measuring instruments shall be identified as follows. All indicating meters shall be of AE / IMP make.

AC ammeter to measure primary current shall be labeled as "AC PRIMARY CURRENT" and AC Voltmeter to measure primary voltage shall be labeled as "AC PRIMARY VOLTAGE".

DC milli-ammeter to measure precipitator current shall be labeled as "PRECIPITATOR CURRENT". The signal to meter shall be from shunt resistor. The meter shall be of moving coil type giving arithmetic mean reading. DC kilo voltmeter to measure precipitator voltage shall be labeled as "PRECIPITATOR VOLTAGE". The meter shall be of moving coil type giving arithmetic mean reading.

5 digit time totalizer shall be labeled as "POWER SUPPLY OPERATION". This shall be non reset able type. The time totalizer shall indicate the cumulative time in hours up to last digit. At the time of dispatch the initial reading of time totalizer shall not exceed two digits.

9.15.0 The EC panel shall be provided with separate LED (Clustered LED ) type indication lamps to indicate MAINS ON, HT ON, ALARM(Common), TRIP (Common), SCR TEMPERATURE HIGH, TR TEMPERATURE HIGH, TR TEMPERATURE VERY HIGH, BUCH. TOP FLOAT, BUCH. BOTTOM FLOAT, UNDER VOLTAGE, ASH LEVEL HIGH, HOPPER TEMPERATURE HIGH, CONVEYOR NOT RUNNING, MINIMUM OIL LEVEL, THERMAL OVERLOAD etc. Necessary Auxiliary contactors shall be provided for this purpose.

9.16.0 No loose component shall be terminated to any of the components. Potentiometers for calibration if any shall be provided in PCB's / Part of cards.

9.17.0 Danger plate and rating shall be fitted on the door front.

9.18.0 Potential free, 5A 230V AC rated "NO" contacts shall be provided for customer use for HT "ON", HT "OFF", Main supply "ON", Trip and Alarm. Also provision shall be made in the panel to receive HVR ON , OFF commands from Remote.

9.19.0 The panel shall be provided with Anti-vibration pads.

9.20.0 COMPONENT IDENTIFICATION AND LABELLING :

\*\*\*\*\*

All the components of Electronic controller shall be identified by fixing anodized Aluminium labels for the items mounted on the door. For components mounted inside the panel / Marshalling box, Aluminium foil sticker shall be followed.

#### 10.0.0 PAINTING OF HV TRANSFORMER :

The internal and external surfaces including fluids filled chambers and structural steel work of transformer shall be sand blasted / approved equivalent method , to remove all rust and scales or foreign adhering material. All steel surfaces in contact with insulating fluid shall be painted with two coats of heat resistant fluid insoluble in insulating fluid. All steel surfaces exposed to weather shall be given a primary coat of zinc chromate, second coat of weather resistant epoxy paint of colour distinct from primary. Finally two coats of glossy fluid and weather resistant non fading paint of shade 631 of IS 5 or as specified by Enquiry / Purchase order, shall be provided . Air drying may be followed for transformers painting. Minimum thickness of paint shall be 50 micron. **If the Enquiry / Purchase order calls for any other painting process, then the same shall be followed.**

#### 11.0.0 PAINTING OF ELECTONIC CONTROLLER

All sheet steel shall be pretreated in tanks in accordance with IS 6005. Degreasing shall be done by alkaline cleaning, rust and scales shall be removed by pickling with acid. After pickling the parts shall be washed in running water. These items shall be rinsed in slightly alkaline hot water and dried. The phosphate coating shall be of class "C" as specified in IS 6005. The phosphates surface shall be rinsed and passivated prior to application, of stove lead oxide primer coating. After primer application, finishing synthetic enamel stoving paint shall be applied. Thickness of paint shall not be less than 50 microns. The final shade shall be 631 of IS 5 or as specified by customer. Peelable coating shall be applied on panel after final painting. **If the Enquiry / Purchase order calls for any other painting process, then the same shall be followed.**

#### 12.0.0 MAKES OF COMPONENTS :

12.1.0 The makes of components indicated above are only tentative. The makes of components are subjected to BHEL approval, which is based on end user requirements. Only the Make of components which are approved by BHEL shall be used. If any specific makes of components are indicated in the Enquiry / Purchase Order, then the specific makes only shall be used. There shall not be any commercial implication on account of such approvals.

#### 13.0.0 DOCUMENTS TO BE SUBMITTED FOR APPROVAL ON PLACEMENT OF PURCHASE ORDER..

13.1.0 General arrangement of HVR, General arrangement of EC, Inside component layout of the EC, Wiring drawing for EC and HVR, Bill of material for EC, Bill of material for HVR. Power and control scheme, Rating and Diagram plate and technical particulars as per IS 2026.

13.2.0 Detailed calculation for selection / sizing of KVA rating of transformer , Rating of Linear reactor, RF choke, Diode stack, HV resistor column, Conservator sizing and transformer tank sizing.

\*\*\*\*\*

13.3.0 Interconnection diagram between HVR and EC panel / other panels.

13.4.0 Six sets of the above drawings shall be submitted to BHEL for approval, before taking up with manufacture.

**14.0.0 O & M MANUAL:**

14.1.0 O&M manual in required numbers, as per Enquiry / Purchase order, shall be supplied along with the dispatch of the EC & HVR. The O&M manual shall be directly sent to BHEL RANIPET.

14.2.0 The O & M manual shall contain relevant GA drawings, power & control schemes, operational write up, detailed bill of materials indicating description, rating, quantity, make etc., wiring drawings, Rating and diagram plate, Do's and Don'ts, details on storage, handling, pre – commissioning points, set parameters, operation spares with part numbers, manufacturer's catalogue for various bought out components etc.,

14.3.0 The scheme drawings shall indicate all the components so that trouble shooting can be made easier. A single drawing explaining all circuit connection shall be furnished.

14.4.0 Exhaustive BOM shall be furnished.

**15.0.0 TESTING :**

The EC & HVR shall be tested based on the following documents:

- (i) BHEL Purchase order
- (ii) BHEL Technical specification
- (iii) Project specific requirements, if any, indicated in the P.O
- (iv) Quality checklist / Quality Plan indicated in the P.O
- (v) Test Procedure TP:109: (latest revision).
- (vi) BHEL approved vendor drawings.

**16.0.0 PACKING**

16.1.0 The equipment shall be properly packed to avoid any damage during storage / transit. The packing shall be weather proof and suitable for out door storage. Necessary provisions / marks for handling shall be provided. Each packing shall contain a packing slip showing all the components, instruction manual, name of supplier, brief equipment description, purchase order number, relevant test certificate, serial number of equipment and destination address. Loose components if any, shall be clearly indicated in packing slip.

16.2.0 Each Electronic controller and High voltage transformer rectifier to be packed separately.

16.3.0 Each crate shall indicate the Purchaser order number, Name and address of the consignee, Approximate weigh, Name of equipment (Electronic controller / High voltage transformer rectifier) , Shipping marking etc.

16.4.0 For Export orders, only Sea worthy packing shall be provided

\*\*\*\*\*

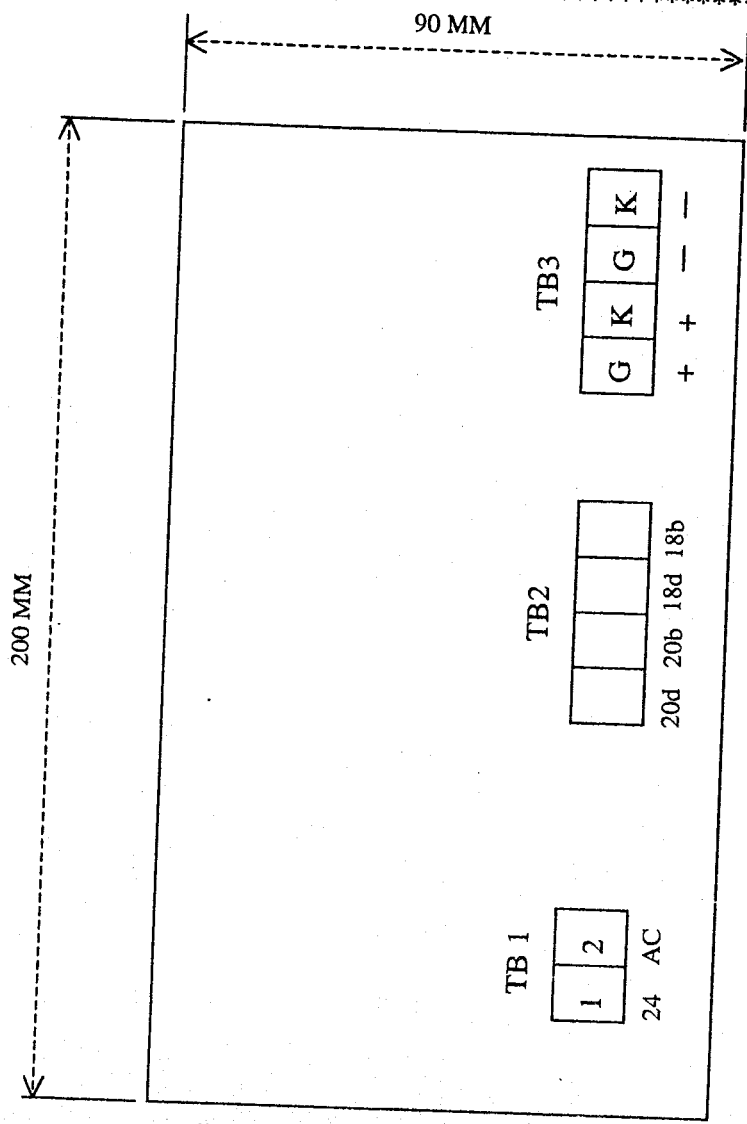

**FIRING CARD DETAIL**

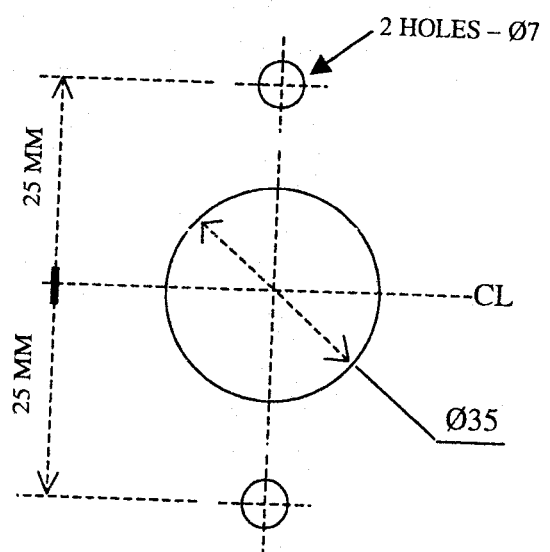

**DRILLING DATA ON PANEL (FOR FIXING INTERLOCK)**

**ANNEXURE TO R-INDENT NUMBER: R-7750868**

**ADDITIONAL REQUIREMENTS OF EC-HVR**

- 01. The HVR shall deliver the rated secondary voltage and current with load connected. when the transformer primary voltage is 373.5V.
- 02. The HVR shall be designed for double voltage double frequency testing.
- 03. Only HRC fuses for power and MCB for control shall be provided. Glass fuses are not acceptable.
- 04. The scheme drawing shall be very clear indicating all the components. The drawing shall be prepared in such a manner that trouble shooting can be made easier. A single drawing explaining all circuit connection shall be furnished.
- 05. Draft O&M manual shall be furnished along with the drawing for Approval.
- 06. Only Auxiliary contactors and power contactors shall be provided. Relays are not permitted.
- 07. Magnetic Oil Level Guage to be linked to Alarm/warning/trip circuit.
- 08. Double compression type cable gland shall be provided as given below for each set:

For EC : 4 Nos. 2C-185 sq. mm. Armoured PVC - FRLS AL. CABLE.  
 1 No 10C-2.5 sq. mm. Armoured PVC-FRLS CU.CABLE.  
 3 Nos. 4C-1.5 sq. mm. Armoured PVC-FRLS Screened CU.CABLE.  
 2 Nos. 3C-2.5 sq. mm. Armoured PVC-FRLS CU.CABLE.

For HVR : 2 Nos 2C-185 sq. mm. Armoured PVC-FRLS AL.CABLE.  
 1 No 10C-2.5 sq. mm. Armoured PVC-FRLS CU.CABLE.  
 1 No 4C- 1.5 sq. mm. Armoured PVC-FRLS Screened CU.CABLE.  
 1 No. 3C-2.5 sq. mm. Armoured PVC-FRLS CU.CABLE.

- 09. The following connectors are to be mounted on suitable DIN rail for ARECA -II

Phoenix make &  
 Type reference

Cable No:1	MSTBVK 2.5/16-G-5.08 – 1 No.
Cable No:2	MSTBVK 2.5/12-G-5.08 – 1 No.
Cable No:3	MSTBVK 2.5/3 -G-5.08 – 1 No.

**TECHNICAL CONFIRMATION CHECKLIST**

- 1.0 Enquiry reference :
- 2.0 Bidder Name :
- 3.0 Bidder offer reference :
- 4.0 Item Description : High voltage Transformer Rectifier and Electronic control panel but without Microprocessor based TR set controller.
- 5.0 Technical confirmation (Page 3 of ECI: TUTICORIN:EC-HVR:REV01) : YES / NO
- 5.1 Compliance to enquiry Technical specification : YES / NO
- 5.2 Compliance to Additional Requirements of EC-HVR as Indicated in the enquiry Document Ref. ECI:TUTICORIN:EC-HVR REV 01 : YES / NO
- 5.3 Rating of EC-HVR as per enquiry : YES / NO
- 5.4 Commissioning of EC-HVR Included in the scope : YES / NO
- 5.5 Supply of O&M Manual Included in the scope : YES / NO
- 5.6 Compliance to Quality Plan/ Checklist indicated in the Enquiry : YES / NO
- 5.7 Compliance to the painting details Indicated in the enquiry Technical Specification : YES / NO

SIGNATURE WITH OFFICIAL SEAL.