	TITLE	SPECIFICATION NO.
	<b>MOTOR DATA SHEET - C</b>	VOLUME II B
		SECTION D
		REV NO. 00 DATE 08/09/2010
		SHEET 2 OF 7

- a. Voltage (Volts)
  - b. Frequency (Hz)
  - c. Combined voltage and frequency
14. Rated speed at rated voltage and frequency(RPM)
15. At rated Voltage and frequency:
- a. Full load current
  - b. No load current
16. Power Factor at
- a. 100% load
  - b. NO load
  - c. Starting.
17. Efficiency at rated voltage and frequency,
- a. 100% load
  - b. 75% load
  - c. 50% load
18. Starting current (amps) at
- a. 100 % voltage
  - b. 85% voltage
  - c. 80% voltage
19. Minimum permissible starting Voltage (Volts)
20. Starting time with minimum permissible voltage
- a. Without driven equipment coupled
  - b. With driven equipment coupled

NAME OF VENDOR			SEAL	REV.	
NAME	SIGNATURE	DATE			

	TITLE	SPECIFICATION NO.
	<b>MOTOR</b>  <b>DATA SHEET - C</b>	VOLUME II B
		SECTION D
		REV NO. 00 DATE 08/09/2010
		SHEET 3 OF 7

21. Safe stall time with 100% and 110% of rated voltage
- a. From hot condition
  - b. From cold condition
22. Torques :
- a. Starting torque at min. permissible voltage(kg-mtr.)
  - b. Pull up torque at rated voltage.
  - c. Pull out torque
  - d. Min accelerating torque (kg.m) available
  - e. Rated torque (kg.m)
23. Stator winding resistance per phase (ohms at 20 Deg.C.)
24.  $GD^2$  value of motors
25. No of permissible successive starts when motor is in hot condition
26. Locked Rotor KVA Input
27. Locked Rotor KVA/KW
28. Vibration limit :Velocity (mm/s)
29. Noise level limit (dBA)

### C. CONSTRUCTIONAL FEATURES

1. Stator winding insulation
  - a. Class & Type
  - b. Winding Insulation Process
  - c. Tropicalised (Yes/No)

NAME OF VENDOR			SEAL	REV.	
NAME	SIGNATURE	DATE			

	TITLE	SPECIFICATION NO.	
	<b>MOTOR DATA SHEET - C</b>	VOLUME	II B
		SECTION D	
		REV NO. 00	DATE 08/09/2010
		SHEET	4 OF 7

- d. Temperature rise over specified maximum ambient temperature of 50 deg C
  - e. Method of temperature measurement
  - f. Stator winding connection
2. Main Terminal Box
- a. Type
  - b. Location (viewed from NDE side)
  - c. Entry of cables(bottom/side)
  - d. Recommended cable size (To be matched with cable size envisaged by owner)
  - e. Fault level (MVA), Fault level duration (sec)
  - f. Cable glands & lugs details (shall be suitable for power cable)
3. Type of DE/NDE Bearing
4. Motor Paint shade
5. Weight of
- a. Motor stator (KG)
  - b. Motor Rotor (KG)
  - c. Total weight (KG)
- D. List of accessories.**
- 1. Space Heaters (Applicable for 30 KW & above motor) (Nos./Power in watts/supply voltage)
  - 2. Terminal Box for Space Heater (Yes/No)
  - 3. Speed switch (Yes/No)  
No of contacts and contact ratings of speed switch

NAME OF VENDOR			SEAL	REV.	
NAME	SIGNATURE	DATE			

	TITLE	SPECIFICATION NO.
	<b>MOTOR DATA SHEET - C</b>	VOLUME II B
		SECTION D
		REV NO. 00 DATE 08/09/2010
		SHEET 5 OF 7

4. Insulation of bearing (Yes/No)
5. Noise reducer(Yes/No)
6. Grounding pads
  - i) No and size on motor body
  - ii) Nos on terminal Box
7. Vibration pads
  - i) Nos and size
  - ii) Location
8. Any other fitments

**E. List of curves.**

1. Torque speed characteristic of the motor
2. Thermal withstand characteristic
3. Starting. current Vs. Time
4. Starting. current Vs speed
5. P.F. and Effi. Vs Load

**F. Additional Data to be filled for each rating of DC Motor**

1. Rated armature voltage (Volt)
2. Rated field excitation (Amp)
3. Permissible % variation in voltage
4. Minimum Permissible Starting voltage (volt)
  - At rated voltage
    - i) Full load Armature current.(Amp)
    - ii) Full load Field current (Amp)

NAME OF VENDOR			SEAL	REV.	
NAME	SIGNATURE	DATE			

	TITLE	SPECIFICATION NO.
	<b>MOTOR</b>  <b>DATA SHEET - C</b>	VOLUME II B
		SECTION D
		REV NO. 00 DATE 08/09/2010
		SHEET 6 OF 7

- iii) No load Armature current (Amp)
6. Full load Field current (Amp)
7. No load Aramature current (Amp)
8. Minimum permissible field current(Amp) to avoid overspeeding at
- i) Maximum permissible voltage
- ii) Rated voltage
- iii) Minimum Permissible Voltage
9. Resistance (indicative Values) in ohm
- i) Armature winding (Arm + IP + Series) at 25 deg.C
- ii) Field Winding at 25 deg. C
10. Inductance (indicative values)
- i) Armature winding
- ii) Field winding
11. Value of trimmer resistance (ohm) to be connected in series with the shunt field to obtain rated speed at
- i) 220 V DC
- ii) 250 V DC
- iii) 187 V DC
12. Value of the external resistance (ohm) required to be connected in series with armature during starting only
13. Technical data sheet for external resistance box
14. GA drawing of motor
15. Starting time calculation

NAME OF VENDOR			SEAL	REV.	
NAME	SIGNATURE	DATE			

	TITLE	SPECIFICATION NO.
	<p style="text-align: center;"><b>MOTOR</b> <b>DATA SHEET - C</b></p>	VOLUME II B
		SECTION D
		REV NO. 00 DATE 08/09/2010
		SHEET 7 OF 7

- 16. Starter resistance design calculation
- 17. Electrical connection diagram of motor

NAME OF VENDOR			SEAL	REV.	
NAME	SIGNATURE	DATE			

THIS IS A PART OF TECHNICAL SPECIFICATION NO.-PE-TS-410-155A-A001

	<b>QUALITY PLAN</b>		CUSTOMER :			PROJECT 1X800MW KOTHAGUDEM			SPECIFICATION :			
	SHEET 1 OF 2		BIDDER/ VENDOR :			TITLE			NUMBER :			
			SYSTEM			QUALITY PLAN NUMBER PED-506-00-Q-006, REV-01			SPECIFICATION TITLE			
					ITEM AC ELECT. MOTORS BELOW 55KW (LV)			SECTION		VOLUME III		
SL. NO.	COMPONENT/OPERATION	CHARACTERISTICS CHECK	CAT.	TYPE/METHOD OF CHECK	EXTENT OF CHECK	REFERENCE DOCUMENT	ACCEPTANCE NORM	FORMAT OF RECORD	AGENCY			REMARKS
									P	W	V	
1	2	3	4	5	6	7	8	9	10			11
1.0	ASSEMBLY	1.WORKMANSHIP 2.DIMENSIONS 3.CORRECTNESS COMPLETENESS TERMINATIONS/ MARKING/COLOUR CODE	MA MA MA	VISUAL -DO- VISUAL	100% -DO- 100%	MANUF'S SPEC MFG. DRG./ MFG. SPEC. MFG.SPEC./ RELEVANT IS	MANUF'S SPEC MFG. DRG./ MFG. SPEC. MFG.SPEC. RELEVANT IS	-DO- -DO- -DO-	2 2 2	- - -	- - -	
2.0	PAINTING	1.SHADE	MA	VISUAL	SAMPLE	MANUFR'S SPEC/BHEL SPEC./RELEVANT STANDARD	BHEL SPEC. SAME AS COL.7	LOG BOOK	2	-	-	
3.0	TESTS	1.ROUTINE, TYPE TEST INCLUDING SPECIAL TEST AS PER BHEL SPEC. 2.OVERALL DIMENSIONS & ORIENTATION	MA MA	-DO- MEASUREMENT & VISUAL	100% 100%	IS-325/ BHEL SPEC./ DATA SHEET APPROVED DRG/DATA SHEET	SAME AS COL.7 APPROVED DRG/DATA SHEET & RELEVANT IS	TEST REPORT INSPN. REPORT	2 2	1*	-	* NOTE -1 & NOTE-3  NOTE -1 & NOTE-3
<b>BHEL</b>			<b>PARTICULARS</b>			<b>BIDDER/VENDOR</b>						
			<b>NAME</b>									
			<b>SIGNATURE</b>									

**THIS IS A PART OF TECHNICAL SPECIFICATION NO.-PE-TS-410-155A-A001**

	<b>QUALITY PLAN</b>		CUSTOMER :			PROJECT 1X800MW KOTHAGUDEM			SPECIFICATION :			
			BIDDER/ :			TITLE			NUMBER :			
	SHEET 2 OF 2		VENDOR			QUALITY PLAN			SPECIFICATION :			
		SYSTEM			NUMBER PED-506-00-Q-006, REV-01			TITLE :				
		ITEM AC ELECT. MOTORS BELOW 55KW (LV)			SECTION			VOLUME III				
SL. NO.	COMPONENT/OPERATION	CHARACTERISTICS CHECK	CAT.	TYPE/METHOD OF CHECK	EXTENT OF CHECK	REFERENCE DOCUMENT	ACCEPTANCE NORM	FORMAT OF RECORD	AGENCY			REMARKS
									P	W	V	
1	2	3	4	5	6	7	8	9	10			11
		3.NAMEPLATE DETAILS	MA	VISUAL	100%	IS-325 & DATA SHEET	IS-325 & DATA SHEET	INSPN. REPORT	2	1	-	
<p>NOTES:</p> <p>1 ROUTINE TESTS ON 100% MOTORS SHALL BE DONE BY THE VENDOR. HOWEVER, BHEL SHALL WITNESS ROUTINE, TYPE TESTS ON RANDOM SAMPLES. THE SAMPLING PLAN SHALL BE MUTUALLY AGREED UPON</p> <p>2 WHERE EVER CUSTOMER IS INVOLVED IN INSPECTION, (1) SHALL MEAN BHEL AND CUSTOMERS BOTH TOGETHER.</p> <p>3 FOR EXHAUST/VENTILATION FAN MOTORS OF RATING UPTO 1.5KW , ONLY ROUTINE TEST CERTIFICATES SHALL BE FURNISHED FOR SCRUTINY.</p> <p><u>Legends for Inspection agency</u></p> <p>1. BHEL/CUSTOMER 2. VENDOR (MOTOR MANUFACTURER) 3. SUB-VENDOR (RAW MATERIAL/COMPONENTS SUPPLIER)</p> <p>P. PERFORM W. WITNESS V. VERIFY</p>												
<b>BHEL</b>			<b>PARTICULARS</b>			<b>BIDDER/VENDOR</b>						
									<b>BIDDER'S/VENDORS COMPANY SEAL</b>			

THIS IS A PART OF TECHNICAL SPECIFICATION NO.-PE-TS-410-155A-A001

		QUALITY PLAN			CUSTOMER :			PROJECT 1X800MW KOTHAGUDEM			SPECIFICATION :		
					BIDDER/ :			TITLE			NUMBER :		
		SHEET 1 OF 9			VENDOR :			QUALITY PLAN			SPECIFICATION :		
					SYSTEM			NUMBER PED-506-00-Q-007, REV-03			TITLE		
SL. NO.	COMPONENT/OPERATION	CHARACTERISTIC CHECK	CAT.	TYPE/METHOD OF CHECK	EXTENT OF CHECK	REFERENCE DOCUMENT	ACCEPTANCE NORM	FORMAT OF RECORD	SECTION			VOLUME III	
										AGENCY			REMARKS
										P	W	V	
1	2	3	4	5	6	7	8	9	10			11	
1.0	RAW MATERIAL & BOUGHT OUT CONTROL												
1.1	SHEET STEEL, PLATES, SECTION, EYEBOLTS	1.SURFACE CONDITION	MA	VISUAL	100%	-	FREE FROM BLINKS, CRACKS, WAVINESS ETC	LOG BOOK	3	-	-		
		2.DIMENSIONS	MA	MEASUREMENT	SAMPLE	MANFR'S DRG./SPEC	MANFR'S DRG./SPEC	-DO-	3	-	-		
		3.PROOF LOAD TEST (EYE BOLT)	MA	MECH. TEST	-DO-	-DO-	-DO-	INSPEC. REPORT	3	-	2		
1.2	HARDWARES	1.SURFACE CONDITION	MA	VISUAL	100%		FREE FROM CRACKS, UN-EVENNESS ETC.	-DO-	3	-	-		
		2.PROPERTY CLASS	MA	VISUAL	SAMPLES	MANFR'S DRG./SPEC BOOK	RELEVANT IS/SPEC.	SUPPLIERS TC & LOG	3	-	2	PROPERTY CLASS MARKING SHALL BE CHECKED BY THE VENDOR	
1.3	CASTING	1.SURFACE CONDITION	MA	VISUAL	100%		FREE FROM CRACKS, BLOW HOLES ETC.	LOG BOOK	3	-	2		
		2.CHEM. & PHY. PROP.	MA	CHEM & MECH TEST	1/HEAT NO.	MANFR'S DRG./SPEC	RELEVANT IS/	SUPPLIER'S TC	3	-	2	HEAT NO. SHALL BE VERIFIED	
		3.DIMENSIONS	MA	MEASUREMENT	100%	MANUFR'S DRG.	MANUFR'S DRG.	LOG BOOK	3	-	2		
1.4	PAINT & VARNISH	1.MAKE, SHADE, SHELF LIFE & TYPE	MA	VISUAL	100% CONTINUOUS	MANFR'S DRG./SPEC	MANFR'S DRG./SPEC	LOG BOOK	3	-	2		
<b>BHEL</b>			<b>PARTICULARS</b>			<b>BIDDER/VENDOR</b>							
			NAME										
			SIGNATURE										
			DATE						BIDDER'S/VENDORS COMPANY SEAL				

THIS IS A PART OF TECHNICAL SPECIFICATION NO.-PE-TS-410-155A-A001

		<b>QUALITY PLAN</b>			CUSTOMER :			PROJECT 1X800MW KOTHAGUDEM		SPECIFICATION :		
		SHEET 2 OF 9			BIDDER/ VENDOR :			TITLE		NUMBER :		
					SYSTEM			QUALITY PLAN NUMBER PED-506-00-Q-007, REV-03		SPECIFICATION :		
					ITEM: AC ELECT. MOTORS 55 KW & ABOVE (LV & MV)			SECTION		VOLUME III		
SL. NO.	COMPONENT/OPERATION	CHARACTERISTIC CHECK	CAT.	TYPE/METHOD OF CHECK	EXTENT OF CHECK	REFERENCE DOCUMENT	ACCEPTANCE NORM	FORMAT OF RECORD	AGENCY			REMARKS
									P	W	V	
1	2	3	4	5	6	7	8	9	10			11
1.5	SHAFT (FORGED OR ROLLED)	1. SURFACE COND.	MA	VISUAL	100%	-	FREE FROM VISUAL DEFECTS	-DO-	3	-	-	VENDOR'S APPROVAL IDENTIFICATION SHALL BE MAINTAINED
		2. CHEM. & PHYSICAL PROPERTIES	MA	CHEM. & PHYSICAL TESTS	1/HEAT NO. OR HEAT TREATMENT BATCH NO	MFG. DRG. SPEC.	RELEVANT IS	SUPPLIER'S TC	3	-	2	
		3. DIMENSIONS	MA	MEASUREMENT	100%	-DO-	MANUFR'S DRG.	LOG BOOK	3	-	2	
		4.INTERNAL FLAWS	CR	UT	-DO-	ASTM-A388	MANUFR'S SPEC. BHEL SPEC.	-DO-	3	2	1	
1.6	SPACE HEATERS, CONNECTORS, TERMINAL BLOCKS, CABLES, CABLE LUGS, CARBON BRUSH TEMP. DETECTORS, RTD, BTD'S	1. MAKE & RATING	MA	VISUAL	-DO-	MANUFR'S DRG. SPEC.	MANUFR'S DRG. SPEC.	-DO-	3	-	2	
		2. PHYSICAL COND.	MA	-DO-	-DO-	-	NO PHYS. DAMAGE, NO ELECTRICAL DISCONTINUITY	-DO-	3	-	2	
		3.DIMENSIONS (WHEREVER APPLICABLE)	MA	MEASUREMENT	SAMPLE	MANUFR'S DRG./ SPEC.	MANUFR'S DRG. / SPEC.	-DO-	3	-	2	
		4.PERFORMANCE/ CALIBRATION	MA	TEST	100%	-DO-	-DO-	INSP. REPORT	3	-	2	
<b>BHEL</b>			<b>PARTICULARS</b>			<b>BIDDER/VENDOR</b>						
			NAME									
			SIGNATURE									
			DATE						BIDDER'S/VENDORS COMPANY SEAL			

THIS IS A PART OF TECHNICAL SPECIFICATION NO.-PE-TS-410-155A-A001

		<b>QUALITY PLAN</b> SHEET 3 OF 9			CUSTOMER :			PROJECT TITLE 1X800MW KOTHAGUDEM			SPECIFICATION NUMBER :		
					BIDDER/ VENDOR :			QUALITY PLAN NUMBER PED-506-00-Q-007, REV-03			SPECIFICATION TITLE :		
					SYSTEM :			ITEM: AC ELECT. MOTORS 55 KW & ABOVE (LV & MV)			SECTION		VOLUME III
SL. NO.	COMPONENT/OPERATION	CHARACTERISTIC CHECK	CAT.	TYPE/METHOD OF CHECK	EXTENT OF CHECK	REFERENCE DOCUMENT	ACCEPTANCE NORM	FORMAT OF RECORD	AGENCY			REMARKS	
1	2	3	4	5	6	7	8	9	P	W	V	11	
1.7	OTHER INSULATING MATERIALS LIKE SLEEVES, BINDINGS CORDS, PAPERS, PRESS BOARDS ETC.	1. SURFACE COND. ETC.  2. OTHER CHARACTERISTICS	MA  MA	VISUAL  TEST	100%  SAMPLE	-  MANUF'S SPEC.	NO VISUAL DEFECTS  MANUF'S SPEC.	INSPT. REPORT  LOG BOOK AND OR SUPPLIER'S TC	3  3	-  -	2  2		
1.8	SHEET STAMPING (PUNCHED)	1. SURFACE COND.  2.DIMENSIONS INCLUDING BURS HEIGHT  3. ACCEPTANCE TESTS	MA  MA  MA	VISUAL  MEASUREMENT  ELECT. & MECH TESTS	100%  SAMPLE  -DO-	-  MANUFR'S DRG. .  MANUF'S SPEC./ RELEVANT IS	NO VISUAL DEFECTS (FREE FROM BURS)  MANUFR'S DRG.  RELEVANT IS	LOG BOOK  -DO-  SUPPLIER'S TC	3  3  3	-  -	-  2  2	FOR MV MOTOR INSULATION/VARNISH THICKNESS SHALL BE MORE THAN THE BURS HEIGHT	
1.9	CONDUCTORS	1. SURFACE FINISH  2.ELECT. PROP. & MECH. PROP	MA  MA	VISUAL  ELECT. & MECH.TEST	100%  SAMPLES	-  RELEVANT IS/ BS OR OTHER STANDARDS	FREE FROM VISUAL DEFECTS  RELEVANT IS/ BS OR OTHER STANDARDS	LOG BOOK  SUPPLIERS TC & VENDOR'S INSPN. REPORTS	3*  3	-  -	2*  2	* MOTOR MANUFACTURER TO CONDUCT VISUAL CHECK FOR SURFACE FINISH ON RANDOM BASIS (10% SAMPLE) AT HIS WORKS AND MAINTAIN RECORD FOR VERIFICATION BY BHEL/CUSTOMER.	
<b>BHEL</b>			<b>PARTICULARS</b>			<b>BIDDER/VENDOR</b>							
			NAME										
			SIGNATURE										
			DATE			BIDDER'S/VENDORS COMPANY SEAL							

THIS IS A PART OF TECHNICAL SPECIFICATION NO.-PE-TS-410-155A-A001

		QUALITY PLAN			CUSTOMER :			PROJECT 1X800MW KOTHAGUDEM			SPECIFICATION :		
		SHEET 4 OF 9			BIDDER/ VENDOR			TITLE			NUMBER :		
		SYSTEM			ITEM: AC ELECT. MOTORS 55 KW & ABOVE (LV & MV)			QUALITY PLAN NUMBER PED-506-00-Q-007, REV-03			SPECIFICATION : TITLE		
								SECTION			VOLUME III		
SL. NO.	COMPONENT/OPERATION	CHARACTERISTIC CHECK	CAT.	TYPE/ METHOD OF CHECK	EXTENT OF CHECK	REFERENCE DOCUMENT	ACCEPTANCE NORM	FORMAT OF RECORD	AGENCY			REMARKS	
									P	W	V		
1	2	3	4	5	6	7	8	9	10			11	
1.10	BEARINGS	3.DIMENSIONS	MA	MEASUREMENT	-DO-	-DO-	-DO-	Log Book	3	-	2		
		1.MAKE & TYPE	MA	VISUAL	100%	MANFR'S DRG./ APPROVED DATASHEET	MANFR'S DRG./ APPROVED DATASHEET	-DO-	3	-	2		
		2.DIMENSIONS	MA	MEASUREMENT	SAMPLE	BHEL DATA SHEET	BHEL DATA SHEET BEARING MANUF'S CATALOGUES	-DO-	3	-	2		
1.11	SLIP RING (WHEREVER APPLICABLE)	3.SURFACE FINISH	MA	VISUAL	100%	-	FREE FROM VISUAL DEFECTS	-DO-	3	-	2		
		1.SURFACE COND.	MA	VISUAL	100%	-	-DO-	-DO-	3	-	-		
		2.DIMENSIONS	MA	MEASUREMENT	SAMPLE	MANUF'S DRG	MANUF'S DRG	-DO-	3	-	-		
		3.TEMP.WITH-STAND CAPACITY	MA	ELECT.TEST	-DO-	MANUF'S SPEC./ BHEL SPEC.	MANUF'S SPEC./ BHEL SPEC.	-DO-	3	-	2		
1.12	OIL SEALS & GASKETS	4.HV/IR	MA	-DO-	100%	-DO-	-DO-	-DO-	3	-	2		
		1.MATERIAL OF GASKET	MA	VISUAL	100%	MANUF'S DRG/SPECS	MANUF'S DRG./ SPECS.	-DO-	3	-	-		
		2.SURFACE COND.	MA	VISUAL	100%	-	FREE FROM VISUAL DEFECTS	-DO-	3	-	-		
		3.DIMENSIONS	MA	MEASUREMENT	SAMPLE	MANUF'S DRG	MANUF'S DRG	-DO-	3	-	-		
BHEL			PARTICULARS			BIDDER/VENDOR							
			NAME										
			SIGNATURE										
			DATE									BIDDER'S/VENDORS COMPANY SEAL	

THIS IS A PART OF TECHNICAL SPECIFICATION NO.-PE-TS-410-155A-A001

		QUALITY PLAN			CUSTOMER :			PROJECT 1X800MW KOTHAGUDEM			SPECIFICATION :		
		SHEET 5 OF 9			BIDDER/ VENDOR			TITLE			NUMBER :		
		SYSTEM			ITEM: AC ELECT. MOTORS 55 KW & ABOVE (LV & MV)			SECTION			VOLUME III		
SL. NO.	COMPONENT/OPERATION	CHARACTERISTIC CHECK	CAT.	TYPE/ METHOD OF CHECK	EXTENT OF CHECK	REFERENCE DOCUMENT	ACCEPTANCE NORM	FORMAT OF RECORD	AGENCY			REMARKS	
1	2	3	4	5	6	7	8	9	P	W	V	11	
2.0	IN PROCESS												
2.1	STATOR FRAME WELDING (IN CASE OF FABRICATED STATOR )	1.WORKMANSHIP & CLEANNESS	MA	VISUAL	100%	-DO-	GOOD FINISH	LOG BOOK	3/2	2	-		
		2.DIMENSIONS	MA	MEASUREMENT	-DO-	MANUF'S DRG	MANUF'S DRG	-DO-	2	-	-		
2.2	MACHINING	1.FINISH	MA	VISUAL	100%	-DO-	GOOD FINISH	LOG BOOK	2	-	-		
		2.DIMENSIONS	MA	MEASUREMENT	-DO-	MANUF'S DRG	MANUF'S DRG	-DO-	2	-	-		
		3.SHAFT SURFACE FLOWS	MA	PT	-DO-	RELEVANT SPEC./ ASTM-E165	MANUF'R'S SPEC./ BHEL SPEC./	-DO-	2	-	1		
2.3	PAINTING	1.SURFACE PREPARATION	MA	VISUAL	100%	MANFR'S SPEC/BHEL SPEC./ RELEVANT STAND	BHEL SPEC. SAME AS COL.7	LOG BOOK	2	-	-		
		2.PAINT THICKNESS (BOTH PRIMER & FINISH COAT)	MA	MEASUREMENT BY ELCOMETER	SAMPLE	-DO-	-DO-	-DO-	2	-	-		
		3.SHADE	MA	VISUAL	-DO-	-DO-	-DO-	Log Book	2	-	-		
		4.ADHESION	MA	CROSS CUTTING & TAPE TEST	-DO-	-DO-	-DO-	Log Book	2	-	-		
BHEL			PARTICULARS			BIDDER/VENDOR							
			NAME										
			SIGNATURE										
			DATE						BIDDER'S/VENDORS COMPANY SEAL				

THIS IS A PART OF TECHNICAL SPECIFICATION NO.-PE-TS-410-155A-A001

		QUALITY PLAN			CUSTOMER :			PROJECT 1X800MW KOTHAGUDEM		SPECIFICATION :		
		SHEET 6 OF 9			BIDDER/ VENDOR			TITLE		NUMBER :		
		SYSTEM			QUALITY PLAN NUMBER PED-506-00-Q-007, REV-03			SPECIFICATION :		TITLE		
		ITEM: AC ELECT. MOTORS 55 KW & ABOVE (LV & MV)			SECTION		VOLUME III					
SL. NO.	COMPONENT/OPERATION	CHARACTERISTIC CHECK	CAT.	TYPE/ METHOD OF CHECK	EXTENT OF CHECK	REFERENCE DOCUMENT	ACCEPTANCE NORM	FORMAT OF RECORD	AGENCY			REMARKS
									P	W	V	
1	2	3	4	5	6	7	8	9	10			11
2.4	SHEET STACKING	1.COMPLETENESS	MA	MEASUREMENT	SAMPLE	MANUFR'S SPEC.	MANUFR'S SPEC.	Log Book	2	-	-	(FOR MOTORS OF 2MW AND ABOVE) * ON 10% RANDOM SAMPLE  FOR MV MOTOR  THREE DIPS TO BE GIVEN
		2.COMPRESSION & TIGHTENING	MA	MEASUREMENT	100%	-DO-	-DO-	Log Book	2	-	-	
		3.CORE LOSS & HOTSPOT	MA	ELECT.TEST	-DO-	-DO-	-DO-	Log Book	2	1*	1	
2.5	WINDING	1.COMPLETENESS	CR	VISUAL	100%	MANUFR'S SPEC./BHEL SPEC.	MANUFR'S SPEC./BHEL SPEC.	Log Book	2	-	-	
		2.CLEANLINESS	CR	-DO-	-DO-	-DO-	-DO-	Log Book	2	-	-	
		3.IR-HV-IR	CR	ELECT. TEST	-DO-	-DO-	-DO-	Log Book	2	-	1	
		4.RESISTANCE	CR	-DO-	-DO-	-DO-	-DO-	Log Book	2	-	1	
		5.INTERTURN INSULATION	CR	-DO-	-DO-	-DO-	-DO-	Log Book	2	-	-	
		6.SURGE WITH STAND AND TAN. DELTA TEST	CR	-DO-	-DO-	-DO-	-DO-	Log Book	2	-	1	
2.6	IMPREGNATION	1.VISCOSCITY	MA	PHY. TEST	AT STARTING	-DO-	-DO-	Log Book	2	-	-	
		2.TEMP. PRESSURE VACCUM	MA	PROCESS CHECK	CONTINUOUS	-DO-	-DO-	Log Book	2	-	-	
		3.NO. OF DIPS	MA	-DO-	-DO-	-DO-	-DO-	Log Book	2	-	1	
BHEL			PARTICULARS			BIDDER/VENDOR						
			NAME									
			SIGNATURE									
			DATE			BIDDER'S/VENDORS COMPANY SEAL						

THIS IS A PART OF TECHNICAL SPECIFICATION NO.-PE-TS-410-155A-A001

		QUALITY PLAN			CUSTOMER :			PROJECT 1X800MW KOTHAGUDEM		SPECIFICATION :		
		SHEET 7 OF 9			BIDDER/ :			TITLE		NUMBER :		
		VENDOR			SYSTEM			QUALITY PLAN		SPECIFICATION :		
		ITEM: AC ELECT. MOTORS 55 KW & ABOVE (LV & MV)			SECTION		VOLUME III		TITLE			
SL. NO.	COMPONENT/OPERATION	CHARACTERISTIC CHECK	CAT.	TYPE/METHOD OF CHECK	EXTENT OF CHECK	REFERENCE DOCUMENT	ACCEPTANCE NORM	FORMAT OF RECORD	AGENCY			REMARKS
									P	W	V	
1	2	3	4	5	6	7	8	9	10			11
2.7	COMPLETE STATOR ASSEMBLY	4.DURATION 1.COMPACTNESS & CLEANLINESS	MA	-DO- VISUAL	-DO- 100%	-DO- -DO-	-DO- -DO-	Log Book	2	-	1	VERIFICATION FOR MV MOTOR ONLY
2.8	BRAZING/COMPRESSION JOINT	1.COMPLETENESS 2.SOUNDNESS	CR	-DO- MALLETT TEST & UT	-DO- -DO-	-DO- -DO-	-DO- -DO-	Log Book	2	-	-	
2.9	COMPLETE ROTOR ASSEMBLY	3.HV 1.RESIDUAL UNBALANCE	MA	ELECT. TEST DYN. BALANCE	-DO- -DO-	-DO- MFG SPEC./ ISO 1940	-DO- MFG. DWG.	Log Book	2	-	1	
		2.SOUNDNESS OF DIE CASTING	CR	ELECT. (GROWLER TEST)	-DO-	MFG. SPEC.	MFG. SPEC.	Log Book	2	-	1	
2.10	ASSEMBLY	1.ALIGNMENT	MA	MEAS.	-DO-	-DO-	-DO-	Log Book	2	-	-	
		2.WORKMANSHIP	MA	VISUAL	-DO-	-DO-	-DO-	Log Book	2	-	-	
		3.AXIAL PLAY	MA	MEAS.	-DO-	-DO-	-DO-	Log Book	2	-	1	
		4.DIMENSIONS	MA	-DO-	-DO-	MFG.DRG./ MFG SPEC.	MFG. DRG/ RELEVANT IS	Log Book	2	-	-	
		5.CORRECTNESS, COMPLETENESS TERMINATIONS/ MARKING/ COLOUR CODE	MA	VISUAL	100%	MFG SPEC. RELEVANT IS	MFG SPEC. RELEVANT IS	Log Book	2	-	-	
		6. RTD, BTD & SPACE HEATER MOUNTING.	MA	VISUAL	100%	MFG SPEC. RELEVANT IS	MFG SPEC. RELEVANT IS	Log Book	2	-	1	
BHEL			PARTICULARS		BIDDER/VENDOR							
			NAME									
			SIGNATURE									
			DATE					BIDDER'S/VENDORS COMPANY SEAL				

**THIS IS A PART OF TECHNICAL SPECIFICATION NO.-PE-TS-410-155A-A001**

		<b>QUALITY PLAN</b> SHEET 8 OF 9			CUSTOMER :		PROJECT 1X800MW KOTHAGUDEM		SPECIFICATION :				
					BIDDER/ VENDOR :		TITLE		NUMBER :		TITLE		
SYSTEM		ITEM: AC ELECT. MOTORS 55 KW & ABOVE (LV & MV)		SECTION		VOLUME III							
SL. NO.	COMPONENT/OPERATION	CHARACTERISTIC CHECK	CAT.	TYPE/ METHOD OF CHECK	EXTENT OF CHECK	REFERENCE DOCUMENT	ACCEPTANCE NORM	FORMAT OF RECORD	AGENCY			REMARKS	
									P	W	V		
1	2	3	4	5	6	7	8	9	10			11	
3.0	TESTS	1.TYPE TESTS INCLUDING SPECIAL TESTS AS PER BHEL SPEC.	MA	ELECT.TEST	1/TYPE/SIZE	IS-325/ BHEL SPEC./ DATA SHEET	IS-325/ BHEL SPEC./ DATA SHEET	TEST REPORT	2	1*	1	* NOTE - 1	
		2.ROUTINE TESTS INCLUDING SPECIAL TEST AS PER BHEL SPEC.	MA	-DO-	100%	-DO-	-DO-	-DO-	2	1 <sup>s</sup>	1	<sup>s</sup> NOTE - 2	
		3.VIBRATION & NOISE LEVEL	MA	-DO-	100%	IS-12075 & IS-12065	IS-12075 & IS-12065	-DO-	2	1 <sup>s</sup>	1	<sup>s</sup> NOTE - 2	
		4.OVERALL DIMENSIONS AND ORIENTATION	MA	MEASUREMENT & VISUAL	100%	APPROVED DRG/DATA SHEET	APPROVED DRG/DATA SHEET & RELEVANT IS	INSPC. REPORT	2	1	-	-	-
		5.DEGREE OF PROTECTION	MA	ELECT. & MECH. TEST	1/TYPE/ SIZE	RELEVANT IS	BHEL SPEC. AND DATA SHEET	TC	2	-	1	TC FROM AN INDEPENDENT LABORATORY, REFER NOTE-3	
		6. MEASUREMENT OF RESISTANCE OF RTD & BTD	MA	-DO-	100%	-DO-	-DO-	-DO-	2	1 <sup>s</sup>	1	<sup>s</sup> NOTE - 2	
		7. MEASUREMENT OF RESISTANCE, IR OF SPACE HEATER	MA	-DO-	100%	-DO-	-DO-	-DO-	2	1 <sup>s</sup>	1	<sup>s</sup> NOTE - 2	
		8. NAMEPLATE DETAILS	MA	VISUAL	100%	IS-325 & DATA SHEET	IS-325 & DATA SHEET	INSPC. REPORT	2	1 <sup>s</sup>	1	<sup>s</sup> NOTE - 2	
		9.EXPLOSION FLAME PROOF NESS (IF SPECIFIED)	MA	EXPLOSION FLAME PROOF TEST	1/TYPE	IS-3682 IS-8239 IS-8240	IS-3682 IS-8239 IS-8240	TC	2	-	1	TC FROM AN INDEPENDENT LABORATORY, REFER NOTE-3	
		10. PAINT SHADE, THICKNESS & FINISH	MA	VISUAL & MEASUREMENT BY ELKOMETER	SAMPLE	BHEL SPEC. & DATA SHEET	BHEL SPEC. & DATA SHEET	TC	2	1 <sup>s</sup>	1	SAMPLING PLAN TO BE DECIDED BY INSPECTION AGENCY <sup>s</sup> NOTE - 2	
BHEL			PARTICULARS			BIDDER/VENDOR							
			NAME										
			SIGNATURE										
			DATE						BIDDER'S/VENDORS COMPANY SEAL				

THIS IS A PART OF TECHNICAL SPECIFICATION NO.-PE-TS-410-155A-A001

		<b>QUALITY PLAN</b>			CUSTOMER :			PROJECT 1X800MW KOTHAGUDEM			SPECIFICATION :		
		SHEET 9 OF 9			BIDDER/ VENDOR :			QUALITY PLAN NUMBER PED-506-00-Q-007, REV-03			SPECIFICATION : TITLE		
		SYSTEM			ITEM: AC ELECT. MOTORS 55 KW & ABOVE (LV & MV)			SECTION			VOLUME III		
SL. NO.	COMPONENT/OPERATION	CHARACTERISTIC CHECK	CAT.	TYPE/METHOD OF CHECK	EXTENT OF CHECK	REFERENCE DOCUMENT	ACCEPTANCE NORM	FORMAT OF RECORD	AGENCY			REMARKS	
									P	W	V		
1	2	3	4	5	6	7	8	9	10			11	
<p>NOTES:</p> <ol style="list-style-type: none"> <li>1 DEPENDING UPON THE SIZE AND CRITICALLY, WITNESSING BY BHEL SHALL BE DECIDED.</li> <li>2 ROUTINE TESTS ON 100% MOTORS SHALL BE DONE BY THE VENDOR. HOWEVER, BHEL SHALL WITNESS ROUTINE TESTS ON RANDOM SAMPLES. THE SAMPLING PLAN SHALL BE MUTUALLY AGREED UPON.</li> <li>3 IN CASE TEST CERTIFICATES FOR THESE TESTS ON SIMILAR TYPE, SIZE AND DESIGN OF MOTOR FROM INDEPENDENT LABORATORY ARE AVAILABLE, THESE TEST MAY NOT BE REPEATED.</li> <li>4 WHEREVER CUSTOMER IS INVOLVED IN INSPECTION, AGENCY (1) SHALL MEAN BHEL AND CUSTOMERS BOTH TOGETHER.</li> </ol> <p><u>Legends for Inspection agency</u></p> <ol style="list-style-type: none"> <li>1. BHEL/CUSTOMER</li> <li>2. VENDOR (MOTOR MANUFACTURER)</li> <li>3. SUB-VENDOR (RAW MATERIAL/COMPONENTS SUPPLIER)</li> </ol> <p>P. PERFORM W. WITNESS V. VERIFY</p>													
BHEL			PARTICULARS			BIDDER/VENDOR							
			NAME										
			SIGNATURE										
			DATE						BIDDER'S/VENDORS COMPANY SEAL				

## ANNEXURE-I

### SUB-VENDOR LIST

The list of approved make of the LT Motors are as mentioned below:

<b>S.No.</b>	<b>LIST OF LT MOTORS</b>
1.	BHARAT BIJLEE LTD.
2.	CROMPTON GREAVES
3.	ASEA BROWN BOVERI
4.	KIRLOSKAR ELECTRIC CO LTD.
5.	NGEF
6.	SIEMENS
7.	MARATHON
8.	GE-POWER
9.	RAJINDRA ELECT INDUSTRIES
10.	LAXMI HYDRAULICS PVT. LTD

However, the final list of makes for the LT Motors is subjected to BHEL/Customer approval, during contract stage, without any commercial implications.





**Explanatory notes for filling up cable list for routing through WinPath, the cable routing program (developed by Corporate R&D) being used in PEM.**

1. For the purpose of clarity, it may please be noted that the information given in regard to the cables to be routed through WinPath as per the system elaborated below is called "Cable List", while the term "Cable Schedule" applies to the cable list with routing information added after routing has been carried out.
2. The cable list shall be entered as an MS Excel file in the format as per enclosed template EXT\_CAB\_SCH\_FORMAT.XLS. No blank lines, special characters, header, footer, lines, etc. shall be introduced in the file. No changes shall be made in the title line (first line) of the template.
3. The field properties shall be as under:
  - a. UNITCABLENO: A/N, up to sixteen (16) characters; each cable shall have its own unique, unduplicated cable number. In case this rule is violated, the cable cannot be taken up for routing.
  - b. FROM: A/N, up to sixty (60) characters; the "From" end equipment/ device description and location to be specified here. Information in excess of 60 characters will be truncated after 60 characters.
  - c. TO: A/N, up to sixty (60) characters; the "To" end equipment/ device description and location to be specified here. Information in excess of 60 characters will be truncated after 60 characters.
  - d. PURPOSE: A/N, up to sixty (60) characters; the purpose (i.e. power cable/ indication/ measurement, etc.) to be specified here. Information in excess of 60 characters will be truncated after 60 characters.
  - e. REMARKS: A/N, up to forty (40) characters; Any information pertinent to routing to be specified here (e.g., cable number of the cable redundant to the cable number being entered). Information in excess of 40 characters will be truncated after 40 characters.
  - f. CABLESIZE: A/N, 7 characters exactly as per the codes indicated below shall be specified here. The program cannot route cables described in any other way/ format.
  - g. PATHCABLENO: Field reserved for utilization by the program. User shall not enter any information here.
4. One list shall be prepared for each system/ equipment (i.e., separate and unique cable lists shall be prepared for each system).
5. The cables shall be described as per the scheme listed below:

A	NN	A	NNN
Cable	No. of cores	Cable code	Cable size
Voltage	(e.g. 01,03,3H, 07)	(See C below)	(e.g. 035,185,2.5, 0.5)
Code (see B below)			

(A) SYSTEM VOLTAGE CODES:

(ac) A = 11KV, B = 6.6KV, C = 3.3KV, D = 415V, E = 240V, F = 110V

(dc) G = 220V, H = 110V, J = 48V, K = +24V, L = -24V

(B) CABLE VOLTAGE CODES:

A = 11KV (Power cables)

**Explanatory notes for filling up cable list for routing through WinPath, the cable routing program (developed by Corporate R&D) being used in PEM.**

- B = 6.6KV (Power cables)
- C = 3.3KV (Power cables)
- D = 1.1KV (LV & DC system power & control cables)
- E = 0.6KV (0.5 sq. mm. Control cables)

(C) CABLE CODES

PVC Copper

- A = Armoured FRLS
- B = Armoured Non-FRLS
- C = unarmoured FRLS
- D = Unarmoured Non-FRLS

PVC Aluminium

- E = Armoured FRLS
- F = Armoured Non-FRLS
- G = unarmoured FRLS
- H = Unarmoured Non-FRLS

XLPE Copper

- J = Armoured FRLS
- K = Armoured Non-FRLS
- L = unarmoured FRLS
- M = Unarmoured Non-FRLS

XLPE Aluminium

- N = Armoured FRLS
- P = Armoured Non-FRLS
- Q = unarmoured FRLS
- R = Unarmoured Non-FRLS

- S = FIRE SURVIVAL CABLES
- T = TOUGH RUBBER SHEATH
- U = OVERALL SCREENED
- V = PAIRED OVERALL SCREENED
- W = PAIRED INDIVIDUAL SCREENED
- Y = COMPENSATING CABLES
- I = PRE-FABRICATED CABLES
- Z = JELLY FILLED CABLES



TITLE:

TECHNICAL SPECIFICATION FOR  
CONDENSATE POLISHING UNIT  
1X800 MW TSGENCO KOTHAGUEM TPS  
STAGE -VII, PALONCHA

SPEC NO: PE-TS-410-155A-A001

VOLUME: II-B

SECTION: C3

REV NO: 01

DATE:

**SECTION – C3**  
**SPECIFIC TECHNICAL REQUIREMENT- C&I**

	<b>1X800 MW KOTHAGUDEM TPS</b>	SPEC NO.: PE-TS-410-145-I	
	<b>CONTROL &amp; INSTRUMENTATION</b>	VOLUME	
	<b>Technical specification for CONDENSATE POLISHING UNIT</b>	SECTION 'D'	
		REV. NO. 00	DATE : 20.03.15
		SHEET	OF

# INDEX

	<p align="center"><b>1X800 MW KOTHAGUDEM TPS</b></p> <p align="center"><b>CONTROL &amp; INSTRUMENTATION</b></p> <p align="center"><b>Technical specification for</b> <b>CONDENSATE POLISHING UNIT</b></p>	SPEC NO.: PE-TS-410-145-I	
		VOLUME	
		SECTION 'D'	
		REV. NO. 00	DATE : 20.03.15
		SHEET	OF

**INDEX:**

1. SPECIFIC TECHNICAL REQUIREMENT
2. DRIVE CONTROL PHILOSOPHY
3. ACTUATOR SPECIFICATION
4. ACTUATOR DATA SHEET
5. INSTUMENT DATASHEET
6. INSTUMENT QUALITY PLAN
7. LCP AND JUNCTION BOX SPECIFICATION
8. LCP QUALITY PLAN
9. CABLE BOQ
10. ERECTION HARDWARE
11. KKS PHILOSOPHY
12. MANDATORY SPARES



Technical specification for  
**CONTROL & INSTRUMENTATION**

**1X800 MW KOTHAGUDEM**

SPEC NO.: **PE-TS-410-145-I**

VOLUME

SECTION

REV. NO. 00

DATE : 10.03.2015

SHEET OF

# SPECIFIC TECHNICAL REQUIREMENT

	<b>Telangana State Power Generation Corporation Ltd. 1x800 MW Kothagudem TPS</b>	<b>SECTION: C</b>
	<b>SPECIFIC TECHNICAL REQUIREMENTS (C&amp;I) CONDENSATE POLISHING UNIT</b>	

**Specific Technical Requirements (C&I):**

- 1.0 Condensate Polishing Unit (CPU) shall be operated from DCS (BHEL's scope).
- 2.0 All instruments shall be terminated on JB/LCP in field and both instrument and JB/LCP are in bidder scope.
- 3.0 Bidder to perform tests of C&I items/instruments/systems as per Quality plans/type test attached in the specification. However, if any test not specified in the quality plan but specified in specification Tests for I&C equipment included elsewhere in specification will have to perform by Bidder without any cost implication.
- 4.0 Bidder to furnish electrical load/UPS load data during detailed engineering
- 5.0 230 V AC UPS Power supply shall be provided by BHEL at a single point, further distribution to various instruments/equipment of the system shall be in bidder scope. Bidder to include necessary power distribution board in his scope. Any power supply other than the above, if required by any instrument/equipment has to be derived by the bidder from the above supply & all necessary hardware for the same shall be in bidder scope. Bidder to submit the power requirement along with the bid.
- 6.0 Bidder's presence is required for 3 Man days (Excluding travel time) at EDN Bangalore during FAT of DDCMIS for certifying correctness & completeness of implementation of Control logic. Intimation to attained FAT shall be informed in 2 days advance. All the expenses like boarding, lodging and travel, Air fare etc. shall be in bidder's scope.
- 7.0 Contractor's C&I representative shall be present at BHEL-PEM for 3 man-days, for preparation of Control scheme of CPU. All the expenses like boarding, lodging and travel, Air fare etc. shall be in bidder's scope.
- 8.0 Bidder's presence is required for 15 Man days (in three visit) at site during commissioning of DDCMIS for assistance related to process correctness. Three visit with total 15 Man days (Excluding travel time) in which one visit shall be of 5 Man days each. All the expenses like boarding, lodging and travel, Air fare etc. shall be in bidder's scope.
- 9.0 Interface of MCC, HT SWGR, field instruments, Actuators etc. with DDCMIS based control system shall be as per Drive Control Philosophy enclosed in specification.
- 10.0 Local control panel if any required for operation shall be in bidder scope.

	<p align="center"><b>Telangana State Power Generation Corporation Ltd. 1x800 MW Kothagudem TPS</b></p>	<p align="center"><b>SECTION: C</b></p>
	<p align="center"><b>SPECIFIC TECHNICAL REQUIREMENTS (C&amp;I) CONDENSATE POLISHING UNIT</b></p>	
<p>11.0</p> <p>12.0</p> <p>13.0</p> <p>14.0</p> <p>15.0</p> <p>16.0</p> <p>17.0</p> <p>18.0</p> <p>19.0</p> <p>20.0</p> <p>21.0</p> <p>22.0</p>	<p>The solenoid operated valves/Dampers/Gate shall have a limit switch for open/close feedback. Solenoid Valve shall be rated for 24V Dc only.</p> <p>Diaphragm seal shall be provided with Instruments having contact with corrosive media.</p> <p>Double root valve shall be provided for all pressure tapings where the pressure exceeds 40kg/cm<sup>2</sup>.</p> <p>Use of process actuated shall be avoided unless unavoidable.</p> <p>Sodium Analyser and Silica Analyser, if applicable, shall be Multi Channel Type.</p> <p>Bidder to include all the instruments (PG, PS, PT, LS, RTD, Analysers etc.) required for the package along with necessary fittings, accessories and valve manifold etc.</p> <p>The solenoid operated valves/ damper/gates shall have limit switches for open/ close feedback. Solenoid valve shall be rated for 24 V DC only.</p> <p>The junction boxes/LIEs for termination of instruments /solenoid valve limit switches etc are in bidder's scope.</p> <p>BHEL shall provide 230 VAC UPS supply feeder at a single point. Further distribution to various instruments shall be in Bidder's scope. Bidder to include necessary power distribution board in his scope. Any power supply other than the above, if required by any instrument/device, has to be derived by the Bidder and all necessary hardware/software for the same shall be in bidder's scope. Bidder to furnish UPS power requirement along with the bid.</p> <p>The make/model of various instruments/items/systems shall be subject to approval of owner/purchaser during detailed engineering stage. No commercial implication in this regard shall be acceptable. In case of any conflict or repetition of clauses in the specification, the more stringent requirements among them are to be complied with.</p> <p>Mandatory spare to be supplied by bidder as per mandatory spares list.</p> <p>The design, manufacture, inspection, testing, site calibration and installation of all C&amp;I equipment and systems covered under this specification shall conform to the latest editions of applicable codes and standards eg. ANSI, ASME, IEEE, ISO, IEC, IGCI, AWS, NFPA, AISC, IGS, SAMA, UBC, UL, NESC, NEMA, ISA, DIN, VDE, IS etc.</p>	

	<p align="center"><b>Telangana State Power Generation Corporation Ltd. 1x800 MW Kothagudem TPS</b></p>	<p align="center"><b>SECTION: C</b></p>
	<p align="center"><b>SPECIFIC TECHNICAL REQUIREMENTS (C&amp;I) CONDENSATE POLISHING UNIT</b></p>	
<p>23.0</p> <p>24.0</p> <p>25.0</p> <p>26.0</p> <p>27.0</p> <p>28.0</p> <p>29.0</p> <p><b>Note:-</b></p>	<p>The scope of cable shall be referred in Electrical scope split sheet in Electrical portion of the specification.</p> <p>Instrument installation drawings are to be provided by bidder. All instrument fitting and erection hardware as per instrument installation diagram shall be in bidder's scope.</p> <p>Every panel-mounted instrument, requiring power supply, shall be provided with a pair of easily replaceable glass cartridge fuses of suitable rating. Every instrument shall be provided with a grounding terminal and shall be suitably connected to the panel grounding bus.</p> <p>Provision for separate Terminal block/wiring diagram for power and control blocks of control panel to be ensured.</p> <p>The make of all the items shall be from approved sub-vendor list.</p> <p>Bidder shall provide Cable Schedule in BHEL excel format provided in Electrical portion of the specification. Also, cable interconnections details for complete system shall be in Bidders' scope.</p> <p>Editable &amp; pdf copy of Drawings/Documents and data to be furnished after award of the contract:</p> <ul style="list-style-type: none"> <li>• Control &amp; operational write-up for the system</li> <li>• Recommended control scheme/ logic diagram</li> <li>• Process manuscript for implementation in DCS</li> <li>• List of Drives ( Solenoid valves etc)</li> <li>• I/O list (DCS)</li> <li>• GA &amp; wiring diagram of local panel.</li> <li>• Power requirement.</li> <li>• Local control panel and field instruments quality plan.</li> <li>• Local control panel &amp; instruments data sheet.</li> <li>• JB grouping document.</li> <li>• Cable schedule and cable interconnection drawing.</li> <li>• Instrument schedule</li> <li>• Alarm Schedule</li> <li>• SOE schedule</li> <li>• Instrument hook-up diagram.</li> <li>• Mandatory spare BOQ</li> <li>• UPS load list</li> <li>• Any other document decided during detailed engineering.</li> </ul>	

 <p>बी एच ई एल <b>BHEL</b></p>	<p><b>Telangana State Power Generation Corporation Ltd. 1x800 MW Kothagudem TPS</b></p>	<p><b>SECTION: C</b></p>
	<p><b>SPECIFIC TECHNICAL REQUIREMENTS (C&amp;I) CONDENSATE POLISHING UNIT</b></p>	
<ol style="list-style-type: none"><li>1. All equipment items shall be of latest design with proven on track record.</li><li>2. The above given scope is indicative &amp; minimum. Any item/ equipment not indicated above however required for the completeness of the system is to be supplied by bidder without any technical, commercial and delivery implication to BHEL.</li><li>3. Documents of C&amp;I System shall be submitted to end user/owner for approval during detail engineering. Changes, if any, shall be accommodated by the bidder without any price/time implication.</li><li>4. Uniformity of make and type of instruments and control components shall be followed throughout for rationalization of spares' inventory, except for certain proprietary items where this requirement cannot be met.</li></ol>		



Technical specification for  
**CONTROL & INSTRUMENTATION**

**1X800 MW KOTHAGUDEM**

SPEC NO.: **PE-TS-410-145-I**

VOLUME

SECTION

REV. NO. 00

DATE : 10.03.2015

SHEET OF

# Drive Control Philosophy

# DCS INTERFACE FOR BIDIRECTIONAL DRIVE (WITH INTEGRAL STARTER)

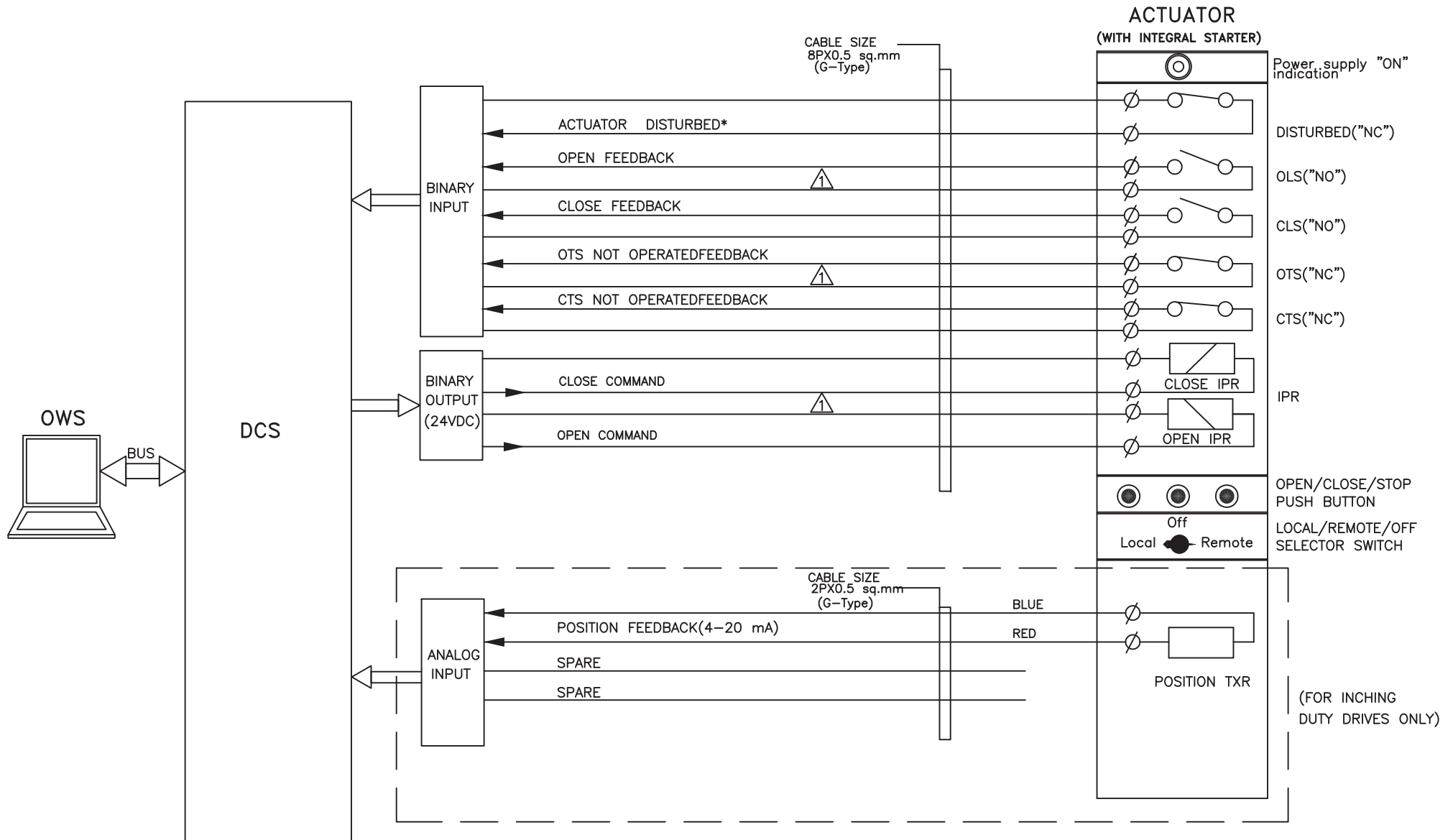

**NOTE:**

\* DISTURBED= Loss of Power supply (1 Phase/3 Phase)/  
 Loss of control supply/ Motor thermostat trip/  
 Thermal over load/Torque open/close cutoff mode/  
 Local/Off/Remote Sel. switch  
 Stop PB optd.



Maharatna Company

PROJECT:	1X800 KOTHAGUEM TPS STAGE-VII, UNIT-12		DRG.NO.	PE-DM-410-145-1002
	TITLE:		DATE	09.03.2015
			REV.NO.	01
			SHT	7 OF 11

# DCS INTERFACE FOR UNIDIRECTIONAL LT DRIVE

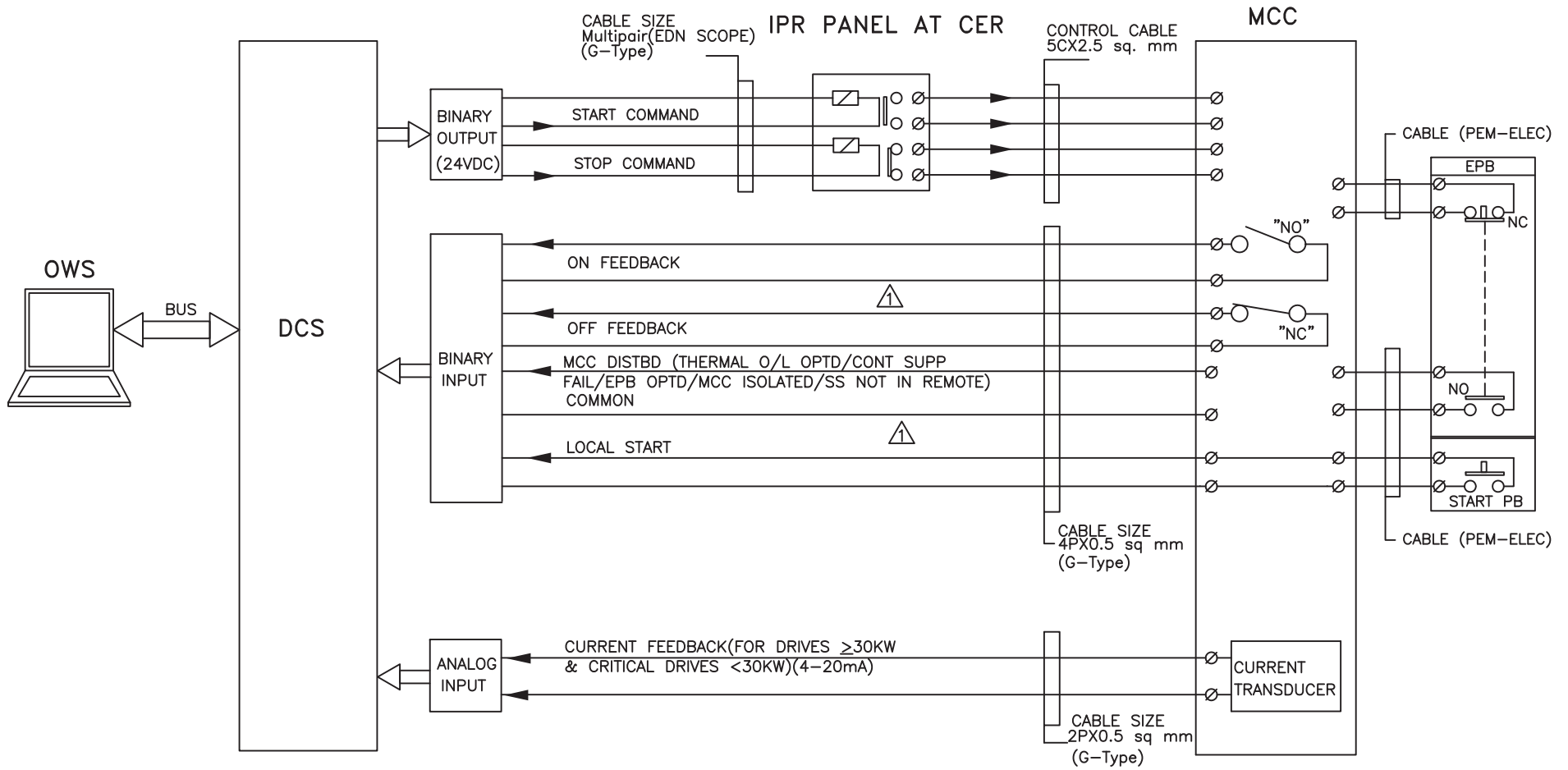

\* FOR LTUD DRIVES ALL LUBE OIL PUMPS, SCANNER AIR FANS, SEAL AIR FANS, 4-20mA CURRENT TRANSDUCER SHALL BE CONSIDERED.



PROJECT:	1X800 KOTHAGUEM TPS STAGE-VII, UNIT-12	DRG.NO.	PE-DM-410-145-1002
TITLE:	DDCMIS INTERFACE FOR UNIDIRECTIONAL LT DRIVE	DATE	09.03.2015
		REV.NO.	01
		SHT	8 OF 11

## DCS INTERFACE FOR SOLENOID DRIVE (24V DC / 240V AC UPS)

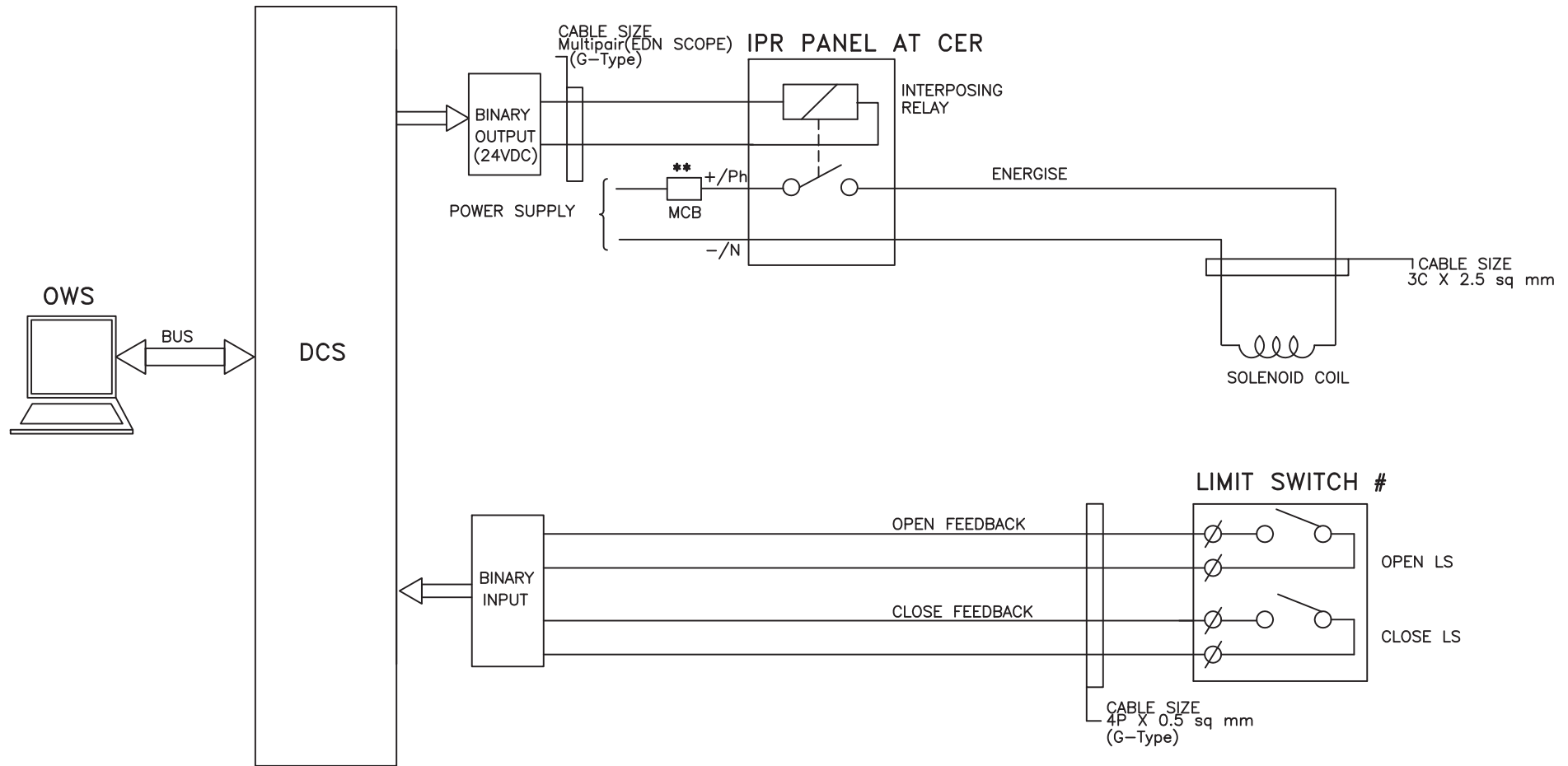

**NOTES:**

\*\* MCB SHALL BE PROVIDED FOR EACH SOLENOID

# FOR ON/OFF TYPE, SOLENOID ACTUATED CONTROL VALVE.



PROJECT:	1X800 KOTHAGUEM TPS STAGE-VII, UNIT-12	DRG.NO.	PE-DM-410-145-1002
		DATE	09.03.2015
TITLE:	DDCMIS INTERFACE FOR SOLENOID DRIVE (SINGLE COIL)	REV.NO.	01
		SHT	9 OF 11

# DCS INTERFACE FOR SOLENOID DRIVE (24V DC / 240V AC UPS)

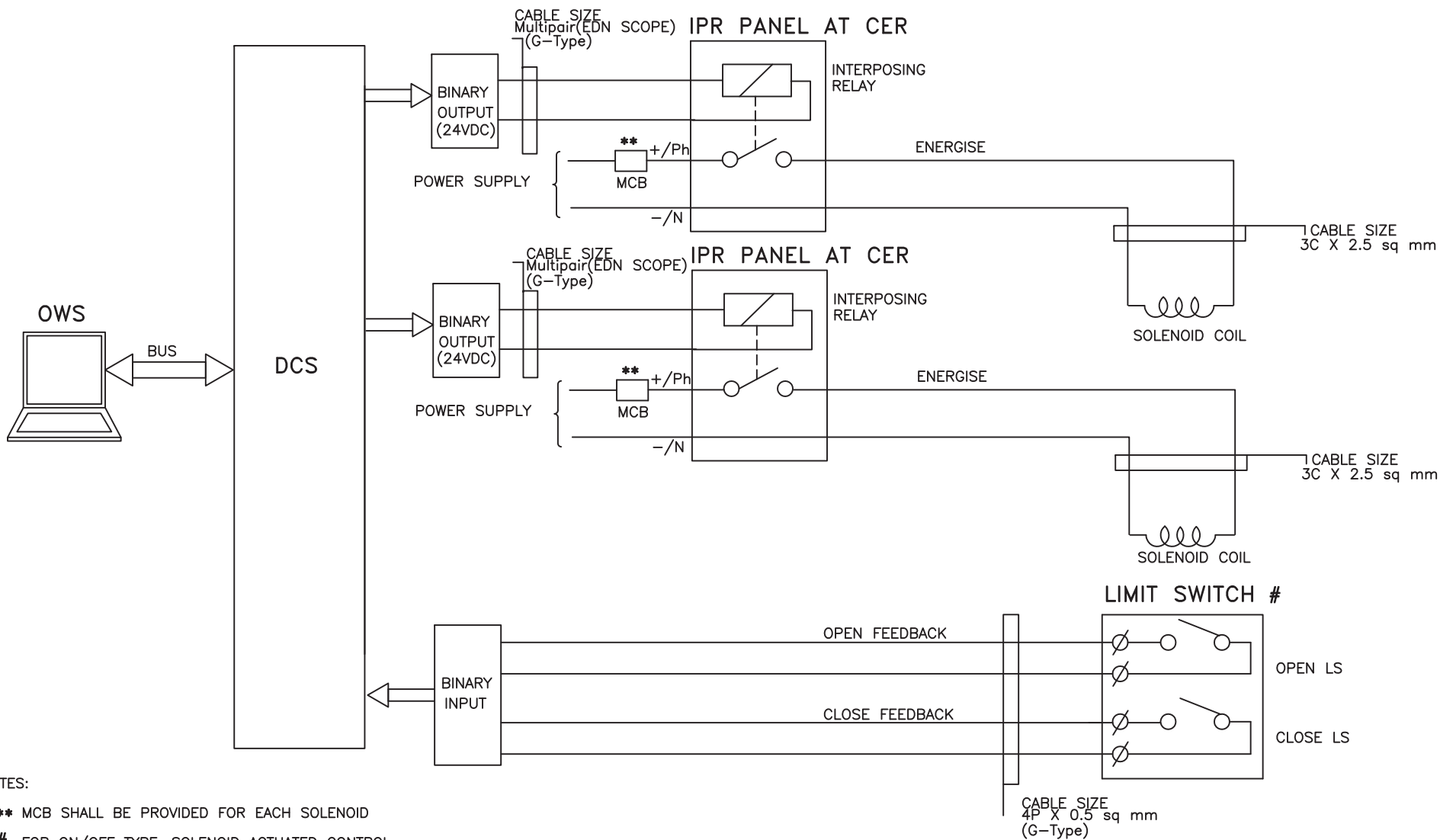

**NOTES:**

- \*\* MCB SHALL BE PROVIDED FOR EACH SOLENOID
- # FOR ON/OFF TYPE, SOLENOID ACTUATED CONTROL VALVE.



<b>PROJECT:</b>	1X800 KOTHAGUDEM TPS STAGE-VII, UNIT-12	<b>DRG.NO.</b>	PE-DM-410-145-1002
		<b>DATE</b>	09.03.2015
<b>TITLE:</b>	DDCMIS INTERFACE FOR SOLENOID DRIVE (DOUBLE COIL)	<b>REV.NO.</b>	01
		<b>SHT</b>	9a OF 11

# DCS INTERFACE FOR HT/LT UNIDIRECTIONAL DRIVES(BREAKER OPERATED)

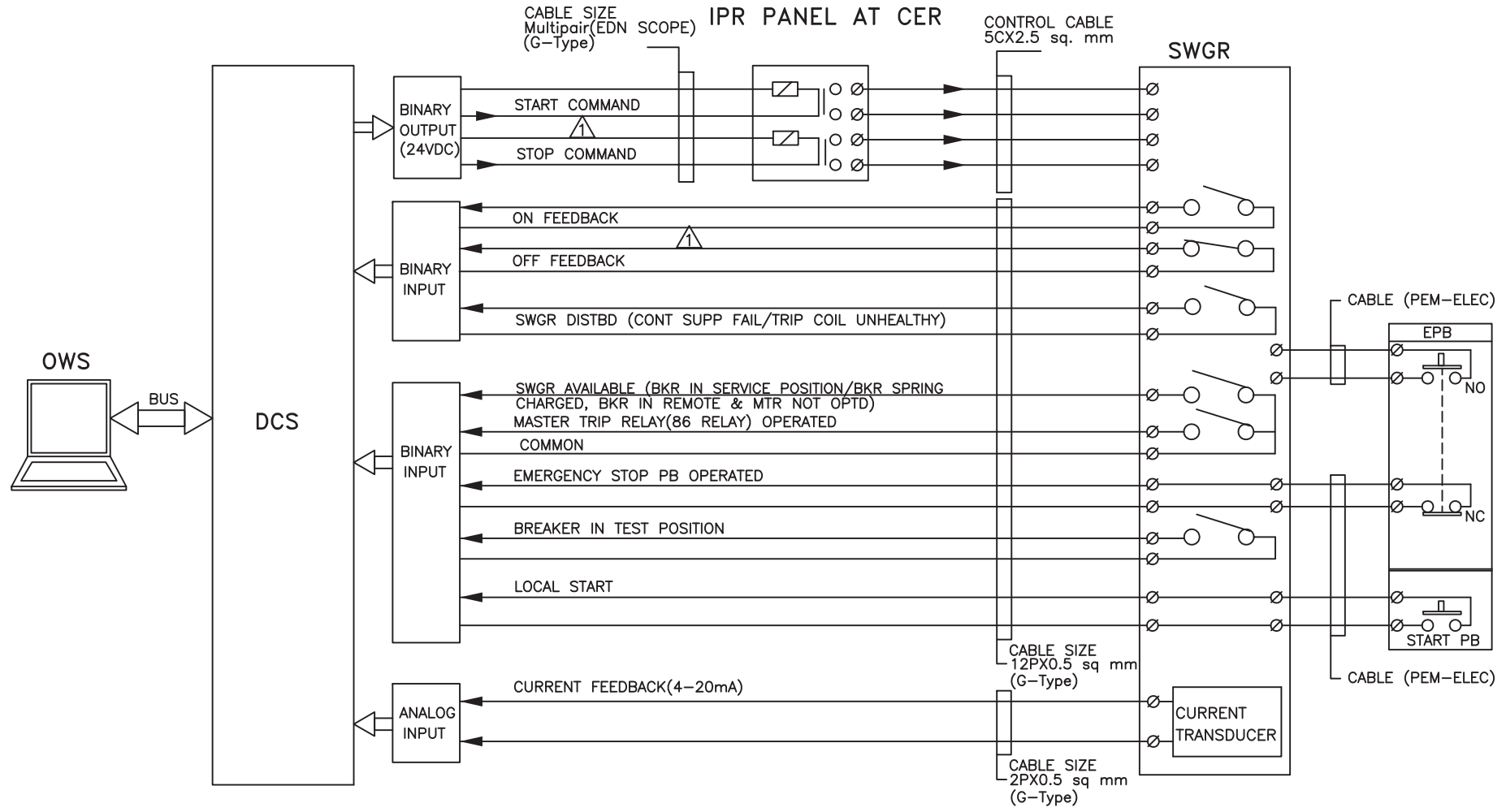

 Maharatna Company	<b>PROJECT:</b>	1X800 KOTHAGUDEM TPS STAGE-VII, UNIT-12	<b>DRG.NO.</b>	PE-DM-410-145-I002
	<b>TITLE:</b>	DDCMIS INTERFACE FOR UNIDIRECTIONAL HT DRIVE	<b>DATE</b>	09.03.2015
			<b>REV.NO.</b>	01
			<b>SHT</b>	10 OF 11

# DCS INTERFACE FOR ANALOG DRIVE (WITH SMART POSITIONER)

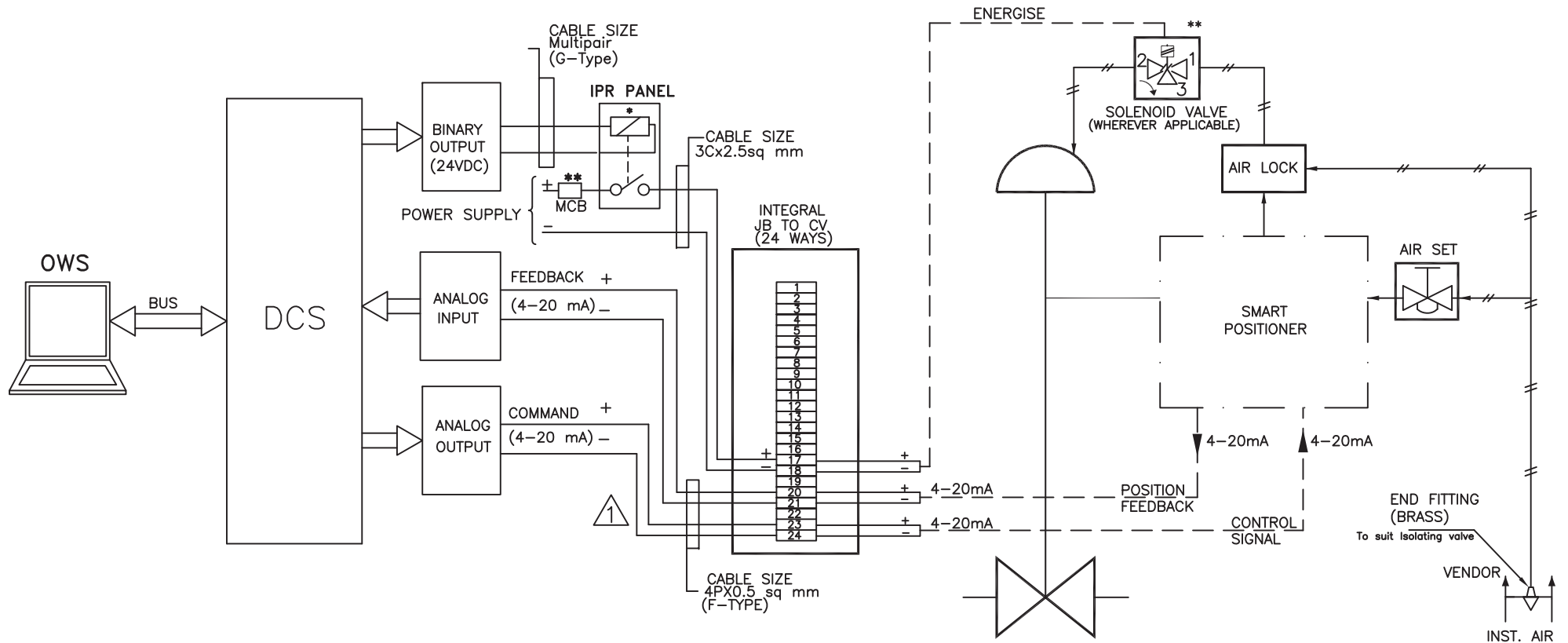

**NOTES:**

\*\* APPLICABLE TO VALVES WHERE PROTECTION OPEN/CLOSE ACTION FOR CONTROL DEMAND OVERRIDING IS REQUIRED.



<b>PROJECT:</b>	1X800 KOTHAGUDEM TPS STAGE-VII, UNIT-12	<b>DRG.NO.</b>	PE-DM-410-145-1002
		<b>DATE</b>	09.03.2015
<b>TITLE:</b>	TYPICAL HOOK-UP DIAGRAM ANALOG DRIVE (WITH SMART POSITIONER)	<b>REV.NO.</b>	01
		<b>SHT</b>	11 OF 11



Technical specification for  
**CONTROL & INSTRUMENTATION**

**1X800 MW KOTHAGUDEM**

SPEC NO.: **PE-TS-410-145-I**

VOLUME

SECTION

REV. NO. 00

DATE : 10.03.2015

SHEET OF

# ACTUATOR SPECIFICATION

**VOLUME: V-A****SECTION-III****TECHNICAL SPECIFICATION  
FOR  
ELECTRIC MOTOR ACTUATORS**

- 1.00.00      **SCOPE**
- 1.01.00      This Section covers the general requirements of Electric Motor Actuators for valves/dampers.
- 1.02.00      All electric motor actuators shall be furnished in accordance with this general specification and the accompanying driven equipment specification. All the electrical actuators shall be INTEGRAL type only.
- 2.00.00      **STANDARDS**
- 2.01.00 All      electrical equipment shall conform to the latest applicable IS, ANSI and NEMA Standards, except when stated otherwise herein or in driven equipment specification.
- 2.02.00      Major standards, which shall be followed, are listed below. Other applicable Indian Standards for any component part even if not covered in the listed standards shall also be followed
- i) IS            -9334
- ii)                IS-325
- 3.00.00      **SERVICE CONDITIONS**
- 3.01.00      The actuator shall be suitable for operation in hot, humid and tropical atmosphere, highly polluted at places with coal dust and/or fly ash.
- 3.02.00      Unless otherwise noted, electrical equipment/system design shall be based on the service conditions and auxiliary power supply given in the general specification.
- 3.03.00      For actuator motor installed outdoor and exposed to direct sun rays, the effect of solar heat shall be considered in the determination of the design ambient temperature.
- 4.00.00      **RATING**
- 4.01.00      For isolating service, the actuator shall be rated for three successive open-close operation of the valve/damper or 15 minutes, whichever is longer.
- 4.02.00      For regulating service, the actuator shall be suitably time-rated for the duty cycle involved with necessary number of starts per hour, but in no case less than 150 starts per hour.