

PRE-QUALIFICATION REQUIREMENTS

Following are the pre-qualification requirements (PQR) for the vendors who are not registered with BHEL-Haridwar for supply of Thermal Insulation of TIP. Offer of registered vendors (i.e. registered for supply of Thermal Insulation of TIP) shall be processed according to their registration status with BHEL at the time of opening of price-bid.

Sl No	Pre-Qualification Requirements	Vendors Confirmation Indicating page no. where documents are placed
1.	Vendor should have an experience in design, supply & application of Thermal Insulation of hot pipes (as per IS 14164:2008 or equivalent) of at least 2 complete SG/TG sets of 200MW or above projects and satisfying the criteria below: <ul style="list-style-type: none"> a. Min pipe size covered= Nb400 b. Temperature of operating fluid= 350°C and above 	
2.	Vendor should furnish the following documents: <ul style="list-style-type: none"> a. Purchase order copy in support of sr. no. 1 above along with all technical annexures like BOM, site data conditions etc. This purchase order should not be older than 5 years as on the date of bid opening. 	
3	Those vendors, who have already received purchase order from BHEL, Haridwar for Thermal Insulation as per sr. no. 1 above, need not to furnish documents pertaining to 2 (a) above.	
4.	For vendors already registered at BHEL, Haridwar for enquiry items, inspection by BHEL nominated inspection agency M/s TUV as per BHEL SQP No. QA/BE/QP/316_Obra Rev. 0 (enclosed). Vendor to endorse and give compliance of the same.	
5.	Quality requirement for new indigenous vendors: <ul style="list-style-type: none"> a. Vendor to submit quality plan in enclosed quality plan format for BHEL approval. b. Inspection by BHEL nominated inspection agency M/s TUV as per BHEL approved quality plan. 	
6.	Quality requirement for new foreign vendors: <ul style="list-style-type: none"> a. Vendor to submit quality plan in enclosed quality plan format for BHEL approval. b. Inspection by third party inspection agency (TUV/LRS/BVQ) as per BHEL approved quality plan. 	
7.	Scope of inspection: Witness of tests as per clause 10.1 and verification as per clause 10.2 of BHEL specification.	

Notes:

1. BHEL would consider the offers and open the price bids of only those bidders, who fulfill the Pre-Qualification requirements (PQRs).

DRG.NO. 412114C5000
REV.NO. 00
DATE: 18/09/14

THERMAL INSULATION SCHEDULE FOR TG INTEGRAL PIPING

PROJECT: 200/210 MW

PROJECT STAGE: CONTRACT

SPEC.NO. ST29005

DESIGN PARAMETERS:

COLD FACE TEMPERATURE: 60 DEG C

AMBIENT TEMPERATURE: 45 DEG C

EMISSIVITY OF AL. SHEET: 0.2

WIND VELOCITY: 0.5 M/S

MATERIALS:

INSULATION MATERIAL: LIGHTLY RESIN BONDED ROCKWOOL
AS PER IS: 8183

DENSITY: 1. 100 KG/M3 FOR HOT FACE TEMP. UPTO 400°C
2. 150 KG/M3 FOR HOT FACE TEMP. ABOVE 400°C

CLADDING MATERIAL: ALUMINIUM SHEET

DESIGN HEAT LOSS AT
CLADDING SURFACE: 180 KCAL/SQM hr

Checked by	Prepared by
S K Gupta SDGM/PED	Navneet Chakrapani Engr- PED

DATA FOR THERMAL INSULATION FOR TURBINE INTEGRAL PIPING

DOC.NO. 412114C5001

REV.00

DATE: 11.09.2014

210 MW RUSSIAN STEAM TURBINE SETS

SL. NO.	SYSTEM DESCRIPTION	O.D. OF PIPE (MM)	HOT FACE TEMP. (DEG.C)	APPROX. LENGTH (M)	VALVES IN LINE		PIPE FITTINGS		
					NOS	SIZE (MM)	NB FLANGES (NOS)	BENDS (NOS)	ELBOWS (NOS)
<u>STEAM ADMISSION PIPES FROM ESV TO HPC</u>									
01		219	535	14	-	-	-	4 (90deg)	-
02		273	535	20	-	-	-	3 (90deg)	-
03		273	535	6	-	-	-	1 (75deg)	-
04		273	535	13	-	-	2	2 (30deg)	-
05		273	535	10	-	-	-	-	-
06		219	535	10	-	-	-	-	-
<u>STEAM ADMISSION PIPES OF IPT</u>									
01		426	535	13	-	-	-	4 (45deg)	-
02		426	535	11	-	-	-	2 (90deg)	-
03		426	535	22	-	-	-	6 (90deg)	-
04		426	535	11	-	-	2	2 (45deg)	-
05		426	535	7	-	-	-	2 (15deg)	-
06		426	535	11	-	-	2	2 (30deg)	-
<u>PIPELINE FOR STEAM SUPPLY TO FRONT SEALS OF HPT AND IPT</u>									
01		26.7	535	25	-	-	-	-	-
02		73	535	25	-	-	-	-	-
<u>PIPELINE FOR HEATING FLANGE AND STUDS FOR HPT AND IPT</u>									
01		26.7	535	52	-	-	-	-	-
02		60.3	535	70	12	50	2	-	-
03		73	535	63	12	70	1	-	-
04		114.3	535	7	-	-	2	-	1
05		168	535	12	-	-	1	-	3
06		219	535	10	-	-	2	-	2
<u>SEAL STEAM SYSTEM</u>									
01		33.4	290	7	-	-	-	-	-
02		33.4	535	25	-	-	-	-	-
03		42.2	290	26	-	-	-	-	-
04		48.3	535	12	-	-	-	-	-
05		60.3	290	65	-	-	-	-	-
06		60.3	465	3	-	-	-	-	-
07		60.3	535	37	-	-	-	-	-

PREPARED BY

Al

APPROVED BY

Harsh

DATA FOR THERMAL INSULATION FOR TURBINE INTEGRAL PIPING

DOC.NO. 412114C5001

REV.00

DATE: 11.09.2014

210 MW RUSSIAN STEAM TURBINE SETS

SL. NO.	SYSTEM DESCRIPTION	O.D. OF PIPE (MM)	HOT FACE TEMP. (DEG.C)	APPROX. LENGTH (M)	VALVES IN LINE		PIPE FITTINGS		
					NOS	SIZE (MM)	NB FLANGES (NOS)	BENDS (NOS)	ELBOWS (NOS)
08		73	290	115	-	-	-	-	-
09		73	535	8	-	-	-	-	-
10		88.9	290	26	-	-	-	-	-
11		114.3	170	24	-	-	-	8	-
12		114.3	290	80	-	-	-	22	-
13		114.3	500	14	-	-	-	1	-
14		114.3	535	9	6	125	-	2	-
15		141.3	170	20	-	-	1	2	-
16		141.3	290	33	-	-	8	6	-
17		141.3	535	10	-	-	-	4	-
18		219.1	465	73	2	200	-	-	-
19		273	290	3	-	-	-	-	-
20		508	465	7	-	-	-	-	-
21		508	170	3	-	-	-	-	-

Note: Above BOM may vary by +/-3%.



PREPARED BY

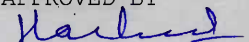

APPROVED BY

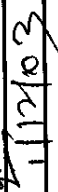
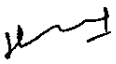

दिनांक एवं हस्ताक्षर SIGN & DATE		उत्पाद मानक STEAM TURBINE ENGINEERING PRODUCT STANDARD	ST 29005 पृष्ठ 23 का 1 Page 1 of 23
सामग्री सूची संख्या को अधिकृत करवा है	SUPERSEDES INVENTORY NO.	BASED ON! RHEL EXPERIENCE	
COPYRIGHT AND CONFIDENTIAL The information on this documents is the property of Bharat Heavy Electrical Limited. It must not be used directly or indirectly in any way detrimental to the interest of the company.		<h1>SPECIFICATION FOR THERMAL INSULATION</h1> <h2>FOR T.G. INTEGRAL PIPING SYSTEM</h2>	
स्वत्वाधिकार एवं गोपनीय इस प्रलेख की सबूत भारत हेवी इलेक्ट्रिकल्स की सम्पत्ति है इसका प्रकाश एवं अप्रकाश रूप से किसी भी तरह प्रयोग, जो कि कंपनी के हित में सापेक्षताएँ हो न किया जाए।			
दिनांक एवं हस्ताक्षर SIGN & DATE	1-12-03		
सामग्री सूची संख्या INVENTORY NO.	P-5788		
	सहमत विभाग AGREED DEPTT.	नाम NAME	दिनांक एवं हस्ताक्षर DATE & SIGNATURE
	QAX	S.S. CHAUHAN	अनुवादक TRANSLATED BY
	TSX	KISHAN LAL	निर्माणकर्ता WORKED BY
		27-11-03	जांचकर्ता CHECKED BY
			पर्यवेक्षणकर्ता SUPERVISED BY
			V.K.GURJA
			स्वीकृति APPROVED : (B.K. BHALLA) AGM (STE)
			जारी ISSUED : STE (TL)
			दिनांक : DATE : 1-6-89
	REV.NO. 04		ST 8.20
	Dt. 04.02.05		निर्माण : PREPARED : STE

दिनांक एवं हस्ताक्षर SIGN & DATE		उत्पाद मानक PRODUCT STANDARD STEAM TURBINE ENGINEERING	ST29005			
सुपरसेड्स इन्वेंटोरी नं. SUPERSEDES INVENTORY NO.	आपूर्ति सूची संख्या को अधिकारित करना है	<p>1.0 <u>INTRODUCTION</u></p> <p>In a thermal power station, thermal insulation of all piping carrying hot fluids is essential for heat economy and protection of operating personnel. In any pipe which is at a temperature higher than its surroundings will loose heat and the amount of heat lost will depend upon the temperature of the fluid conveyed and the thermal conductivity of the piping material. The heat lost through bare pipes increases with:</p> <p>(a) Increase in the temperature of fluid conveyed.</p> <p>(b) Air velocity of the surroundings.</p> <p>Providing proper and adequate insulation on to the facilities and equipments controls heat transfer and maintain the required skin temperatue. The use of high quality insulation can return 20% or more per year on the investment.</p> <p>2.0 <u>SCOPE</u></p> <p>This specifications covers the design, technical requirements and essential particulars for the supply, application & finishing of the thermal insulation complete with all auxiliary materials for the integral piping systems for thermal power stations. Thermal insulation will be applied over integral steam piping having a rated operated temperature of above 60°c for the protection of the operating person & for energy conservation.</p> <p>2.1 The scope of supply shall be defined in data sheet of the project.</p> <p>(a) The description of the components to be insulated.</p> <p>(b) Maximum continuous operating temperature of the components.</p> <p>(c) Design ambient temperature.</p> <p>(d) Type of insulation ordered.</p> <p>(e) Cold face temperature of the insulation above ambient.</p> <p>(f) Other instruction and notes concerning the design, manufacture and supply of insulation.</p> <p>2.2 Attachment, devices & accessories shall form the part of the scope of supply.</p> <p>2.3 Application of the insulation shall be done at site after consultation with or at the request of the chief of the erection group of BHEL at site.</p> <p>2.4 In case the requirements specified in the data sheet for a particular project are different than what is given in this specification, the data sheet requirements shall be considered as final and binding for that project.</p> <p>2.5 The pipe lengths given in data of the insulation schedule are inclusive of the equivalent length of tees/stub and reducer. The vertical / near vertical runs of piping are included in the pipe length given in the data of insulation schedule. Additional supporting arrangements are required for insulation on vertical / near vertical piping. The bidder should include the charges for these supporting arrangements in the contract cost based on his experience. No breakup of vertical and horizontal runs are to be furnished to the bidder.</p>				
COPYRIGHT AND CONFIDENTIAL The information on this documents is the property of Bharat Heavy Electrical Limited. It must not be used directly or indirectly in any way detrimental to the interest of the company.						
स्वत्वाधिकार एवं गोपनीय इस प्रलेख में दी गई सूचना भारत हेवी इलेक्ट्रिकल्स की संपत्ति है इसका प्रकाश एवं अप्रकाश रूप से किसी भी तरह प्रयोग, जो कि कंपनी के हित में हानिकारक हो न किया जाए।						
दिनांक एवं हस्ताक्षर SIGN & DATE						
आपूर्ति सूची संख्या INVENTORY NO.	REV. NO. 04		निर्माणाकर्ता WORKED BY	S.K.G.		12.11.03
P-5788			जांचकर्ता CHECKED BY	V.K.G.		12.11.03

चिनांक एवं दिनांक SIGN & DATE		उत्पाद मानक STEAM TURBINE ENGINEERING PRODUCT STANDARD	ST29005	
सामग्री सूची संख्या का INVENTORY NO.	SUPERSEDES INVENTORY NO.		पृष्ठ 23 का 3 Page 3 of 23	
COPYRIGHT AND CONFIDENTIAL The information on this documents is the property of Bharat Heavy Electrical Limited. It must not be used directly or indirectly in any way detrimental to the interest of the company	<p>2.6 Data furnished for the items to be insulated is based on pipe erection drawings. No physical measurement of insulation work will be done. The conversion factors for the valve and fittings will be taken from IS:14164.</p> <p>3.0 <u>DESIGN AND PERFORMANCE REQUIREMENTS</u></p> <p>3.1 For the design of the insulation shall be assumed that the surface temperature of the equipment is taken equal to the temperature of the steam. Heat loss at the surface of insulation shall not exceed 180 Kcal / m²h unless specified in data sheet.</p> <p>3.2 In principal all the equipments operating above 60°C shall be insulated. However the contractor shall be guided by BHEL regarding the scope as per clause No.2.</p> <p>3.3 If the ambient temperature is not specified in the data sheet, the same shall be assumed as 40°C.</p> <p>3.4 Insulation thickness shall be completed based on the design parameters given in data sheet of the project. The thickness given in insulation schedule shall be reviewed by the bidder.</p> <p>3.5 Insulation shall be supplied in thickness 25, 40, 50, 65 and 75mm. Higher thickness shall be made up in multiple layers from them. The breakup of thickness of multiple layers is given under the column insulation thickness in the insulation schedule.</p> <p>4.0 <u>MATERIALS</u></p> <p>4.1 <u>INSULATING MATERIALS</u></p> <p>The insulating materials and protective covering shall be new and fresh, incombustible , non-hygroscopic and shall be guaranteed to withstand continuously and without deterioration the maximum temperature to which they will be subjected under the specified application. The insulation material and any component of the finished insulation job shall not react chemically by itself or in combination with water or moisture to form the substances which are more actively corrosive to the applied surfaces than water or moisture alone. The material shall not offer substance to fungus or vermin and must not pose a health hazard. The bidder shall submit with the bid the details of application of protective coatings or other methods he proposes to use for corrosion protection of insulated surface.</p>			
स्वत्वाधिकार एवं गोपनीय इस प्रलेख में दी गई सूचना भारत के दो इलेक्ट्रिकल्स की सम्पत्ति है इसका प्रत्यक्ष एवं अप्रत्यक्ष रूप से किसी भी तरह प्रयोग, जो कि कंपनी के हित में हानिकारक हो न किया जाए।	चिनांक एवं दिनांक SIGN & DATE 14.8.04			
सामग्री सूची संख्या INVENTORY NO. P-5788	REV. NO. 04	निर्माणकर्ता WORKED BY S.K.G.	जांचकर्ता CHECKED BY V.K.G.	7/7/04 7.7.04



PRODUCT STANDARD
STEAM TURBINE ENGINEERING

ST 29005

PAGE 4 OF 23

SIGN & DATE

SUPERSEDES
INVENTORY No.

COPYRIGHT AND CONFIDENTIAL

The information on this document is the property of BHARAT HEAVY ELECTRICALS LIMITED. It must not be used directly or indirectly in any way detrimental to the interest of the company.

SIGN & DATE

22/6/89

INVENTORY No.

P-5788

REV.
NO.
04

The material of insulation used for mattress shall be bonded mineral (rock) as per IS8183.

If Preformed pipe section are used, it shall be as per IS9842.

4.2 SHEATHING MATERIAL

The sheathing material for all insulated piping & equipment shall be aluminium sheet confirming to IS 737. Unless otherwise specified in Data sheet, the thickness of aluminium sheathing to be used shall be as follows:

a) Pipes of 450 mm (18 inch.) and above; over outside diameter of insulation :- 1.219 mm (18 SWG).

b) Pipes of 150 mm (6inch) and above; over outside diameter of insulation :- 0.914 mm (20 SWG).

c) Pipes less than 150 mm (6inch); over outside diameter of insulation :- 0.711 mm (22SWG)

4.3 BINDING & LACING WIRE

Binding & lacing wire shall be 20 SWG galvanized steel wire. Where interface temperature is 400°C or more, the binding wire shall be 20 SWG stainless steel wire.

4.4 STRAPS & BANDS

All straps & bands shall be galvanized steel. For securing aluminium sheathing material, stainless steel or anodized aluminium bands shall be used. Bands shall be 20 mm wide & 0.6 mm thick.

4.5 SCREWS

Screws shall be of self tapping type & shall be cadmium/zinc plated.

5.0 APPLICATION OF INSULATION

5.1 GENERAL

The application of thermal insulation is highly skilled job contrary to the general belief. Badly fitted/laid insulation can lead to greater heat loss or surface

WORKED BY:- *Rizam*CHECKED BY:- *Sanjay*



PRODUCT STANDARD
STEAM TURBINE ENGINEERING

ST 29005

PAGE 5 OF 23

SIGN & DATE

SUPERSEDES
INVENTORY No.

COPYRIGHT AND CONFIDENTIAL
The information on this document is the property of BHARAT HEAVY ELECTRICALS LIMITED.
It must not be used directly or indirectly in any way detrimental to the interest of the company.

SIGN & DATE

INVENTORY No.

2-7-6/89

P. 5768

REV.
No.
04

temperature than that estimated & also to constant maintenance. Ample provision shall be made for maximum possible thermal movement & the insulation shall be applied in a manner which will avoid breaking or telescoping due to alternate periods of expansion & contraction. A single layer of insulation shall not be more than 75 mm thick.

The following are some of the points to be considered in the application of insulation

a) Surfaces must be clean, dry, & free from grease, loose scale, moisture etc. before application of insulation.

b) Insulation thickness on flanges & valves should be equal to that of the adjacent/associated pipes.

c) Where contamination by chemicals or oil spillage is possible, it is important that precaution be taken to avoid contamination of insulation.

d) Pipe hangers & supports and any penetrations should be covered in such a way that moisture cannot penetrate.

e) The bare insulation must be stored in a proper place (indoor) to avoid contamination which will lead to change in weight & thermal conductivity values.

f) Rigid sections should have staggered joints where more than one layer is involved & they must be held in close contact with pipe & fitting face by means of wire or bands.

5.2 PIPING :-

5.2.1 For insulation of piping with preformed pipe sections the same shall be applied over the pipe and finally insulation shall be held in position with 15 mm wide aluminium band at not greater than 400 mm spacing.

5.2.2 For insulation of piping with mattresses having backing GI wire or SS wire netting, the required lengths & shapes are cut from the blankets & wrapped on the piping with edges pulled together tightly at the longitudinal joint and secured by lacing wire & this joint shall be at lower side.

If the interface temperature is 400°C or more the wire netting shall be from 20 SWG stainless steel wire and having hexagonal opening of 25 mm size. Otherwise each layer of mattress shall have GI wire netting from 20 SWG & having hexagonal opening of 25 mm size. The ends of all wire loops shall be firmly twisted together with pliers, bent over & carefully pressed into the surface of the insulation.

Preformed insulation & mattress insulation on vertical or near vertical piping must be supported in position by means of metal rings & at intervals as per enclosed sketches.

GI band/Aluminium bands are to be used for tightly securing the different layers of insulation.

5.2.3 Piping bends shall be insulated to the same specification/ as adjacent straight piping and should form a smooth external surface. Where preformed material is used, it

WORKED BY:- *Rigam*CHECKED BY:- *Shankar*



PRODUCT STANDARD

ST 29005

STEAM TURBINE ENGINEERING

PAGE 6 OF 23

SIGN & DATE

SUPERSEDES
INVENTORY No.

COPYRIGHT AND CONFIDENTIAL
 The information on this document is the property of BHARAT HEAVY ELECTRICALS LIMITED.
 It must not be used directly or indirectly in any way detrimental to the interest of the company.

SIGN & DATE

INVENTORY No.

22/6/89

P-5788

REV.
NO.
04

should be cut lobster back finish and wired or strapped into position.

5.2.4 All insulation shall be protected by an outer covering of aluminium sheathing. All insulation sheathing joints shall be sealed and made effectively weather & waterproof. All flat surfaces shall be adequately sloped to prevent pools of water collecting. The sheathing shall be protected internally with two coats of anti corrosive paint as per IS 158. The jackets shall be installed with the longitudinal lap joint at 45° below the horizontal for horizontal pipes and the joints sealed with sealing compound.

Arrangements for securing the metal finish over the insulation shall ensure that direct metal contact between the insulated surface and outer metal cladding is avoided. 4 mm thick asbestos board packing shall be used as interfaces to thermally isolate the metal covering from supporting arrangements. There shall be over lapping of 50 mm on both longitudinal & circumferential joints. The screws shall be provided at not greater than 150 mm spacing. Sealing compound is to be applied at all sheathing joints. The overlapping in outer casing should always be at the bottom for horizontal piping so that no rain water enters into the insulation through the joints & the lapping must be done so that water will have a natural drainage. In case of vertical & inclined piping, circumferential overlapping is made such that no rain water enters into the insulation through the joints by proper lapping sequence.

5.2.5 All joints in the insulation shall be staggered. For multiple layers of insulation the different layers shall be applied so that the butt joints of one layer do not coincide with those of the other layer.

6.0 VALVES & FLANGES INSULATION

The insulation on all valves & flanged joints shall be enclosed in a removable jacketing so that it may be removed without disturbing the concerned equipment or piping. The thickness of insulation shall be same as that of the pipe line in which these valves and fittings are located. A typical arrangements shown in drawing at sheet no 15.

7.0 GENERAL INSTRUCTIONS FOR ERECTION OF INSULATION

a) Persons doing the actual job can alter the method of fixing of sheet metal as and when necessary, only after consulting the concerned field engineer.

b) Care shall be taken to see that the flexible insulation mattresses are not unduly compressed.

c) The day to day insulation works are covered by sheathing or with suitable protective materials to prevent the rain water entry.

WORKED BY:— *Rigan*CHECKED BY:— *Shunda*



PRODUCT STANDARD
STEAM TURBINE ENGINEERING

ST 29005

PAGE 7 OF 23

SIGN & DATE

SUPERSEDES
INVENTORY No.

COPYRIGHT AND CONFIDENTIAL
The information on this document is the property of BHARAT HEAVY ELECTRICALS LIMITED.
It must not be used directly or indirectly in any way detrimental to the interest of the company.

SIGN & DATE

22/6/89

INVENTORY No.

P.5788

REV.
No.
04

d) The indicated insulation thickness are minimum requirements which should be maintained, and are based on LRB mattresses. If the bidder desires to use pipe section or combination of pipe section & LRB mattresses, the same should be done after prior approval of design engineer.

e) Where junctions between bodies of different diameter occur and difference of insulation thickness is specified, the greater thickness is to be continued for a length equal to one diameter of the smaller body and then smoothly tapered to the required smaller thickness over a length equal to two diameters of the smaller body.

f) Once the insulation is laid walking on the insulated pipe should be avoided. Suitable scaffoldings are to be used. Similarly slinging of pipes over the insulation should be avoided.

g) The layers** of wool mattresses to be adopted, to obtain the specified insulation thickness, are as per table below unless otherwise specified

Thickness of insulation(mm)	Ist layer	IIInd layer	IIIrd layer	IVth layer
80	40	40	--	--
100	50	50	--	--
110	65	50	--	--
120	75	50	--	--
130	65	40	25	--
140	75	65	--	--
150	75	75	--	--
200	75	75	50	--

**If the mattress thickness combination are indicated in the insulation schedule, the above instruction is to be ignored. The necessary guide lines of fixing arrangement for pipe section & mattresses are given in the drawings at sheet nos 10 & 11.

h) Insulation Fixing Arrangements:-
Typical fixing arrangements for insulation of pipes & pipe fittings are shown vide drawings listed below;

i) Fixing arrangement pipe section and lightly bonded mattresses/ mattresses at sheet nos. 10, 12 & 13.

WORKED BY: - *Rigam*

CHECKED BY: - *[Signature]*



PRODUCT STANDARD

ST 29005

STEAM TURBINE ENGINEERING

PAGE 8 OF 23

SIGN & DATE

SUPERSEDES
INVENTORY No.

COPYRIGHT AND CONFIDENTIAL

The information on this document is the property of BHARAT HEAVY ELECTRICALS LIMITED, it must not be used directly or indirectly in any way detrimental to the interest of the company.

SIGN & DATE

INVENTORY No.

P-5768

2-16/89

REV.
NO.
04

- ii) Fixing arrangements for lightly bonded mattress at sheet nos 11,12 & 13.
- iii) Lugs at sheet no 14.
- iv) Flats at sheet no. 15.
- v) Fixing of insulation on valves at sheet no. 16.
- vi) Insulation of tee at sheet no. 17.
- vii) Insulation of elbow at sheet no. 18.
- viii) Pipe clamp carbon steel at sheet no. 19.
- ix) Pipe clamp alloy steel at sheet no. 20.

8.0 PROTECTION OF MATERIALS DURING STORAGE

The supplier shall protect the insulation materials from weather at all times from delivery to finish. Decking & covering tarpaulins alone are not adequate for any length of time & shall not be allowed except in extreme emergencies and only for short periods. Stacking of insulating materials directly on ground shall not be done.

9.0 GUARANTEES

The supplier shall guarantee that if the specified maximum surface temperatures are exceeded on actual measurement, the supplier shall either replace the insulation with a superior material or provide additional insulation thickness at the BHEL'S/ site engineers discretion at no extra cost to the BHEL.

The supplier shall also guarantee the quality of the materials used & workmanship for a period of 18 months from the date of commissioning. Any defects arising from faulty materials or workmanship during this period shall be rectified by the supplier at no extra cost to BHEL.

10.0 INSPECTION & TESTING





10.1 Thermal insulating material :-

Supplier shall arrange for carrying out all the tests for establishing thermal conductivity values, physical & chemical properties as required by relevant IS & or BS codes and standards. The tests shall be done on representative samples drawn from each lot of insulation material to be supplied under this specification & prior intimation shall be given so that BHEL can depute their representative to witness any or all the tests. For thermal conductivity values, test certificates from independent authorized testing agency (subject to BHEL'S approval) shall be furnished to BHEL for approval.

10.2 Other materials :-

For other materials i.e. cladding sheet, wire netting, binding wires, stitching & lacing wires etc., manufacturers correlated test certificates as per relevant codes & standards shall be furnished. In case correlating test certificates are not available, the supplier shall arrange to carry out necessary tests in presence of BHEL'S representative.

WORKED BY: - *Rigam*CHECKED BY: - *Shinde*

दिनांक एवं हस्ताक्षर SIGN & DATE		उत्पाद मानक STEAM TURBINE ENGINEERING PRODUCT STANDARD	ST29005 पृष्ठ 23 का 9 Page 9 of 23			
सामग्री सूची संख्या को अधिकृतित करना है	SUPERSEDES INVENTORY NO.	<p>All test certificates shall be furnished & written approval shall be taken from BHEL before commencement of the supply of material.</p> <p>11.0 DOCUMENTS TO BE SUBMITTED</p> <p>Two copies of the following pre-approval documents shall be submitted by the bidder along with the offer :-</p> <p>(i) Thermal conductivity values of the insulating materials at various mean temperatures not older than 2 years for densities 100, 120 & 150 Kg/m³ from government approved lab for information.</p> <p>(ii) Manufacturer's descriptive and illustrative literature for insulating materials offered with complete properties as per relevant standards.</p> <p>(iii) Quality plan duly signed on BHEL format for approval.</p> <p>(iv) Total bill of material of each item, giving the material specification, density / size / thickness, quantity and the wastage allowance considered shall be indicated in Data Sheet / Insulation schedule, alongwith its thickness calculation.</p>				
COPYRIGHT AND CONFIDENTIAL. The information on this documents is the property of Bharat Heavy Electrical Limited. It must not be used directly or indirectly in any way detrimental to the interest of the company.						
स्वत्वाधिकार एवं गोपनीय इस दस्तावेज में दी गई सूचना भारत भारती इलेक्ट्रिकल्स की सम्पत्ति है इसका प्रत्यक्ष एवं अप्रत्यक्ष रूप से किसी भी तरह प्रयोग, जो कि कंपनी के हित में हानिकारक हो न किया जाए ।						
हस्ताक्षर एवं दिनांक SIGN & DATE	 11/12/05					
सामग्री सूची संख्या INVENTORY NO.	REV. NO.		निर्माणकर्ता WORKED BY	S.K.G.		4/2/05
P-5788	04		जांचकर्ता CHECKED BY	V.K.G.		04.02.05

PRODUCT STANDARD

ST 29005

STEAM TURBINE ENGINEERING

PAGE 10 OF 23



SIGN & DATE

SUPERSEDES INVENTORY No.

COPYRIGHT AND CONFIDENTIAL
The information on this document is the property of BHARAT HEAVY ELECTRICALS LIMITED. It must not be used directly or indirectly in any way detrimental to the interest of the company.

SIGN & DATE

INVENTORY No. P-5788

REV. NO. 04

WORKED BY: - *Rigam*

CHECKED BY: - *Shunder*

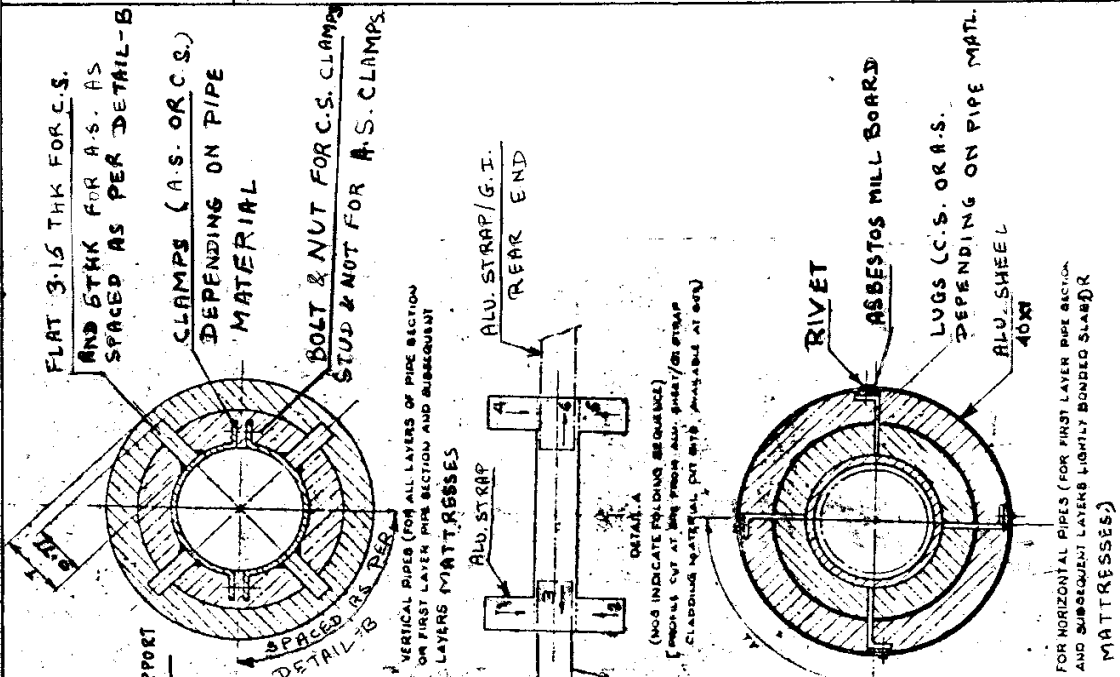

GI BAND 30X0.71
 SECURED TIGHTLY ON
 FINAL LAYER AS PER
 DETAIL - A AND FASTENED
 WITH TWO NOS OF SELF
 TAPPING SCREWS
 SELF TAPPING SCREWS
 2 Nos.



PRODUCT STANDARD
STEAM TURBINE ENGINEERING

ST 29005

PAGE 11 OF 23

INVENTORY No. P-5788	SIGN & DATE 22/4/89	COPYRIGHT AND CONFIDENTIAL The information on this document is the property of BHARAT HEAVY ELECTRICALS LIMITED. It must not be used directly or indirectly in any way detrimental to the interest of the company.	SUPERSEDES INVENTORY No.	SIGN & DATE
REV. NO. D4				

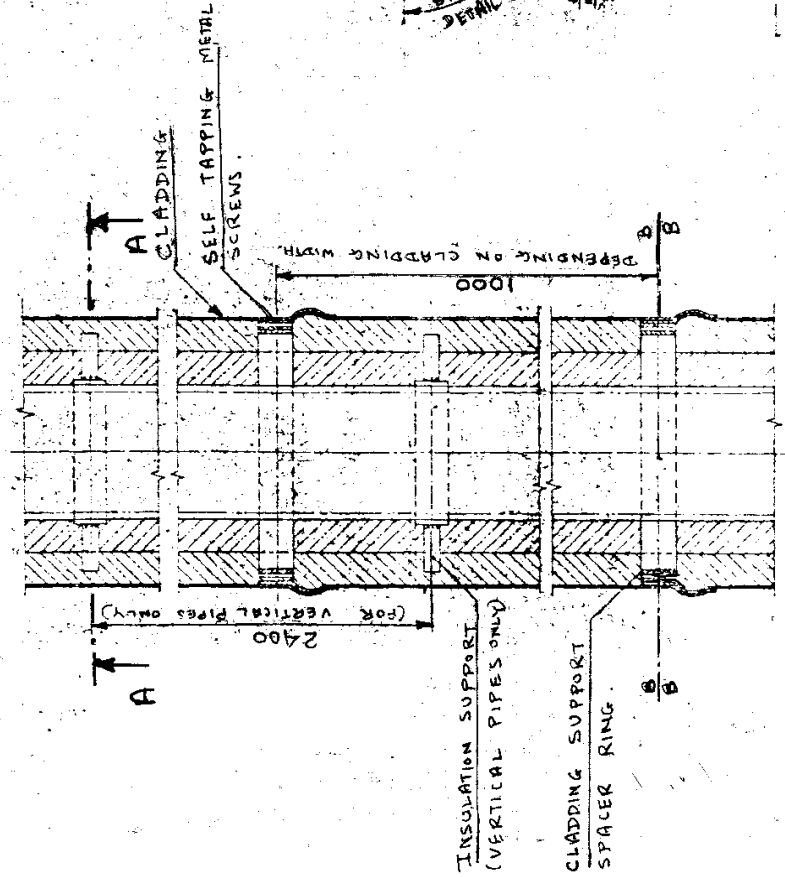
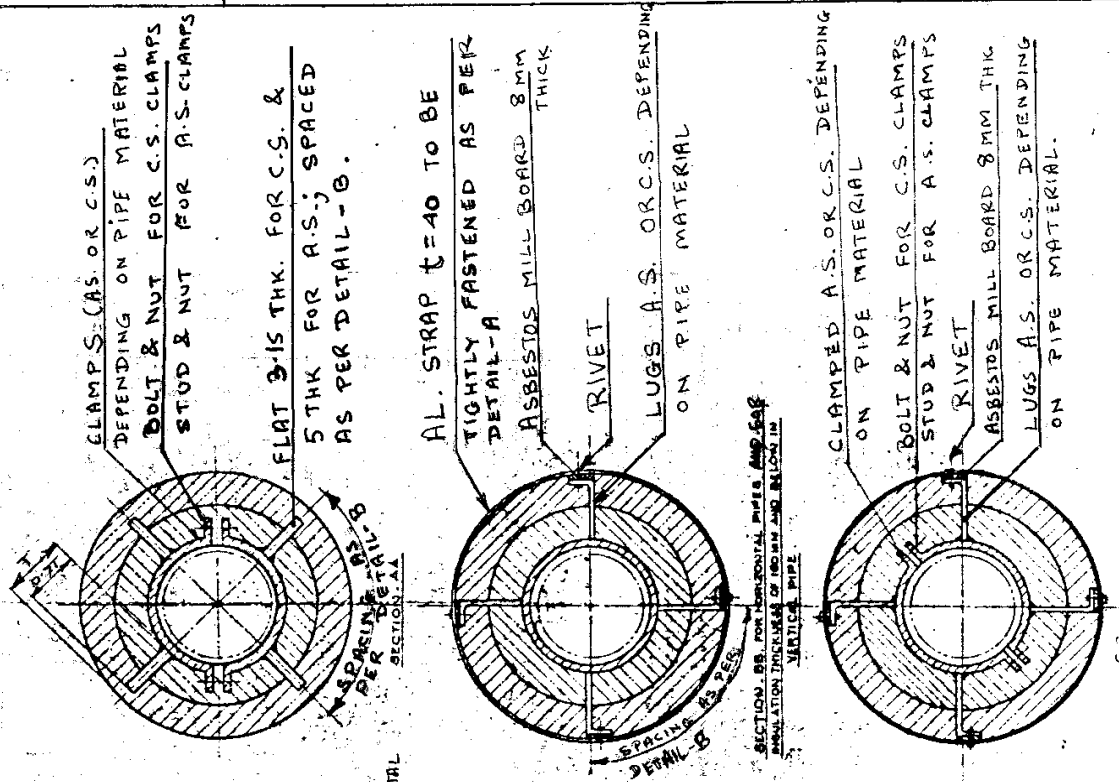

WORKED BY: - Rigan

CHECKED BY: - [Signature]



PRODUCT STANDARD
STEAM TURBINE ENGINEERING

ST 29005

PAGE 12 OF 23

SIGN & DATE

SUPERSEDES
INVENTORY No.

COPYRIGHT AND CONFIDENTIAL

The information on this document is the property of BHARAT HEAVY ELECTRICALS LIMITED. It must not be used directly or indirectly in any way detrimental to the interest of the company.

SIGN & DATE

INVENTORY No.

P-5788 20/6/89

REV.
NO.
04**NOTES ON ERECTION :-****A. (ONLY PIPE SECTION)**

1. Fix support spider on vertical pipes. Bottom most spider at tangent point of bend/tee.
2. Commence insulation of all layers except last layers of insulation, from support spider level in vertical pipes.
3. Fit each layer of insulation and secure with 30 x 0.71 GI bands at spacing as shown. Secure it tightly by cutting the alu. sheet as per detail-A.
4. Secure last layer of insulation and fasten it at a GI band 30 x 0.71 (as detail-A).
5. Fix cladding sheet and apply sealant.
6. For horizontal pipes use GI bands 30 x 0.71 and secure it as per detail-A.

B. FIRST LAYER PIPE SECTION AND SUBSEQUENT LAYERS LRB**MATTRESSES OR MATTRESSES.**

1. For horizontal pipes secure tightly the first layer of pipe section using 30 x 0.71 GI bands and as per detail-A.
2. Insert lugs for horizontal pipes and secure it tightly using alu. sheet 40 x 1 as per detail-A.
3. Fit in asbestos mill board and rivet.
4. Insert the LRB mattresses or mattresses with field cut slots from edge in felt and wire netting to clear lugs.
5. Fix cladding sheet and apply sealant.
6. For fixing of insulation in vertical pipes follow the same as the one for pipe section.



C. GENERAL

- a) After proper folding (as per detail-A) the ends are to be properly fastened by using two nos. self tapping screws per band.
- b) Lugs/flats are issued in standard length running meters. They are to be cut at site depending on insulation thickness.

D. NOTES ON APPLICATION

1. Fix insulation support spiders on vertical pipes. Bottom most spider at tangent point of bend/tee at bottom.
2. Fix cladding support spacer ring at specified intervals by using aluminium strap tightly (as per detail-A).
3. Commence insulation on all layers of insulation except last layer from support spider level in vertical pipes.
4. Insert insulation at support spacer rings locations with field cut slots from edge in felt and wire netting to clean lugs/projection.
5. Stitch wire netting together at all edges and field cuts.

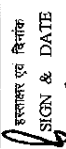
WORKED BY: - *Rigam*CHECKED BY: - *Rigam*

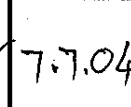
चिह्नक एवं दिनांक SIGN & DATE		उत्पाद मानक STEAM TURBINE ENGINEERING PRODUCT STANDARD	ST29005 पृष्ठ 23 का 13 Page 13 of 23									
सामग्री सूची संख्या को सुपरसेडस इन्वेंटरी नम्बर & सुपरसेडस इन्वेंटरी नम्बर	<ol style="list-style-type: none"> 6. Adjacent layers of insulation to be disposed to result in 50 mm overlap. 7. Fit last layer of insulation. 8. All gaps in insulation to be filled with cuttings & finished. 9. Provide and fix cladding with sealing compound. 10. Lugs and flats are issued for standard height. It has to be cut at site depending on insulation thickness (refer insulation schedule for the thickness of insulation). 11. This is applicable for LRB mattresses or mattresses (both for horizontal and vertical piping). 											
COPYRIGHT AND CONFIDENTIAL The information on this documents is the property of Bharat Heavy Electrical Limited. It must not be used directly or indirectly in any way detrimental to the interest of the company.	<p style="text-align: center;"><u>DETAIL-B</u></p> <table border="1" style="width: 100%; border-collapse: collapse;"> <thead> <tr> <th style="text-align: left;">OUTER DIA. OF PIPE</th> <th style="text-align: right;">NO.OFF</th> </tr> </thead> <tbody> <tr> <td>Upto 219</td> <td style="text-align: right;">4</td> </tr> <tr> <td>273 to 406</td> <td style="text-align: right;">6</td> </tr> <tr> <td>Above 406</td> <td style="text-align: right;">8</td> </tr> </tbody> </table> <p>E. Inspection at site during and after application of insulation shall be carried out as stipulated in the enclosed field quality plan.</p> <p>F. <u>CROSS REFERRED STANDARDS :-</u></p> <p>IS:737</p> <p>IS:8183</p> <p>IS:9842</p> <p>IS:14164</p>				OUTER DIA. OF PIPE	NO.OFF	Upto 219	4	273 to 406	6	Above 406	8
OUTER DIA. OF PIPE	NO.OFF											
Upto 219	4											
273 to 406	6											
Above 406	8											
स्वत्वाधिकार एवं गोपनीय इस दस्तावेज में की गई सूचना भारत में ही इलेक्ट्रिकल्स की सम्पत्ति है इसका प्रयोग एवं अपरयोग अन्य से किसी भी तरह प्रयोग, जो कि कंपनी के हित में हानिकारक हो न किया जाए ।												
चिह्नक एवं दिनांक SIGN & DATE  14.8.04												
सामग्री सूची संख्या INVENTORY NO. P-5788	REV. NO. 04		निर्माणकर्ता WORKED BY S.K.G.	 7/7/04	जांचकर्ता CHECKED BY V.K.G.	 7.7.04						



PRODUCT STANDARD
STEAM TURBINE ENGINEERING

ST 29005

PAGE 14 OF 23

SIGN & DATE
SUPERSEDES
INVENTORY No.

COPYRIGHT AND CONFIDENTIAL
The information on this document is the property of BHARAT HEAVY ELECTRICALS LIMITED. It must not be used directly or indirectly in any way detrimental to the interest of the company.

INVENTORY No.
SIGN & DATE

P-5788

22/6/89

REV. NO. 04

WORKED BY: - *Rigam*

CHECKED BY: - *[Signature]*

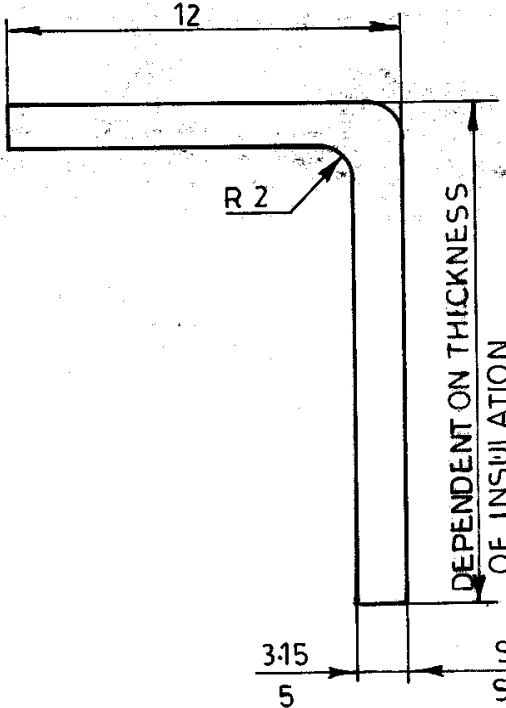

LUGS

INVENTORY No. P-5788 SIGN & DATE 22/6/89

SUPERSEDES INVENTORY No. _____ SIGN & DATE _____

COPYRIGHT AND CONFIDENTIAL
 The information on this document is the property of BHARAT HEAVY ELECTRICALS LIMITED. It must not be used directly or indirectly in any way detrimental to the interest of the company.

PRODUCT STANDARD
STEAM TURBINE ENGINEERING

FORM ST 29005
 PAGE 16 OF 23

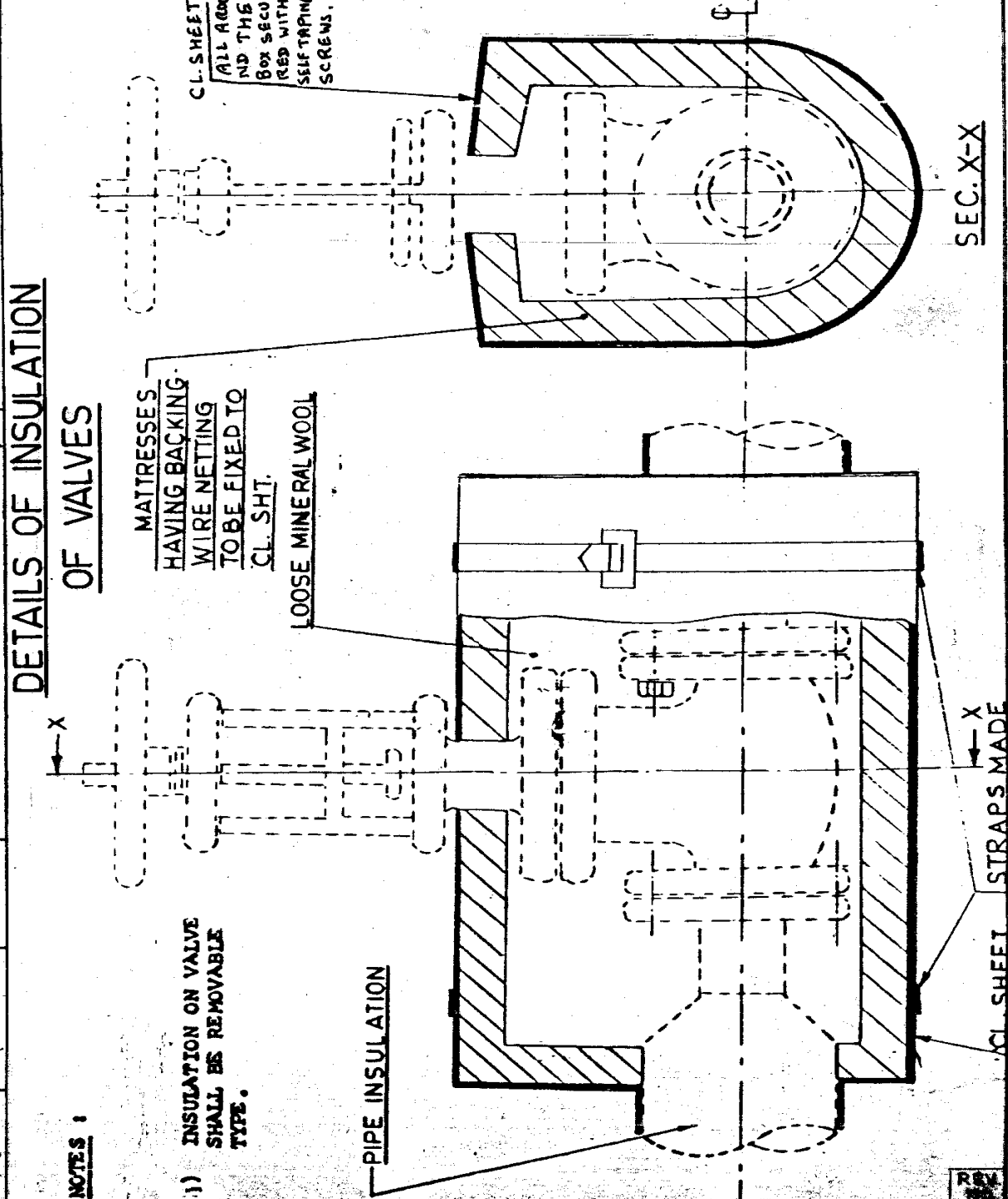

DETAILS OF INSULATION OF VALVES

- NOTES :**
- INSULATION ON VALVE SHALL BE REMOVABLE TYPE.

CL. SHEET
 ALL ABOVE AND THE BOX SECURED WITH SELF TAPPING SCREWS.

MATTRESSES HAVING BACKING WIRE NETTING TO BE FIXED TO CL. SHT.

LOOSE MINERAL WOOL

PIPE INSULATION

STRAPS MADE FROM CL. SHEET

SEC. X-X

WORKED BY: Riga CHECKED BY: [Signature]



PRODUCT STANDARD
STEAM TURBINE ENGINEERING

ST 29005

PAGE 17 OF 23

INVENTORY No. P-5788	SIGN & DATE vsl/6/89	COPYRIGHT AND CONFIDENTIAL The information on this document is the property of BHARAT HEAVY ELECTRICALS LIMITED. It must not be used directly or indirectly in any way detrimental to the interest of the company.	SUPERSEDES INVENTORY No.	SIGN & DATE

FIXING OF INSULATION ON TEES

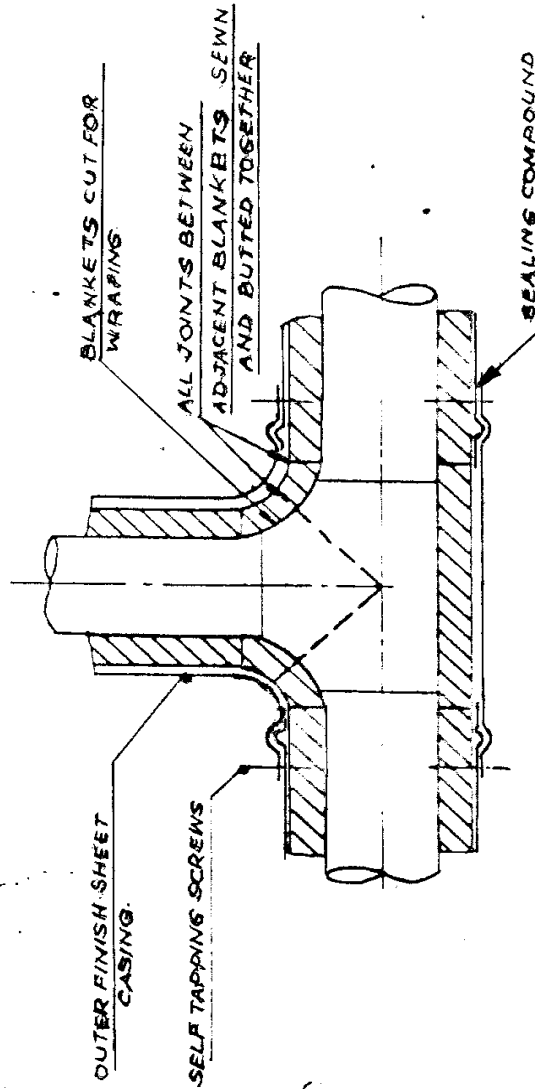

TEE INSULATION
(WITH MATTRESS INSULATION)

WORKED BY:- *Rigan*

CHECKED BY:- *Randu*

REV. NO. 04



PRODUCT STANDARD

ST 29005

STEAM TURBINE ENGINEERING

PAGE 18 OF 23

SIGN & DATE

SUPERSEDES INVENTORY No.

COPYRIGHT AND CONFIDENTIAL
The information on this document is the property of BHARAT HEAVY ELECTRICALS LIMITED. It must not be used directly or indirectly in any way detrimental to the interest of the company.

SIGN & DATE

INVENTORY No.

22-11-09

P-5708

REV. 04

FIXING OF INSULATION ON BENDS / ELBOWS

SHEET METAL CLADDING

ALL JOINTS BETWEEN ADJACENT BLANKETS SEWN & BUTTED TOGETHER.

SEALING COMPOUND TO BE APPLIED ON SHEET.

CASING JOINTS BLANKETS CUT FOR BEING WRAPPED AROUND THE ELBOW/ BEND.

ALL METAL SHEETS AT JOINTS TO OVERLAP BY 40 mm.

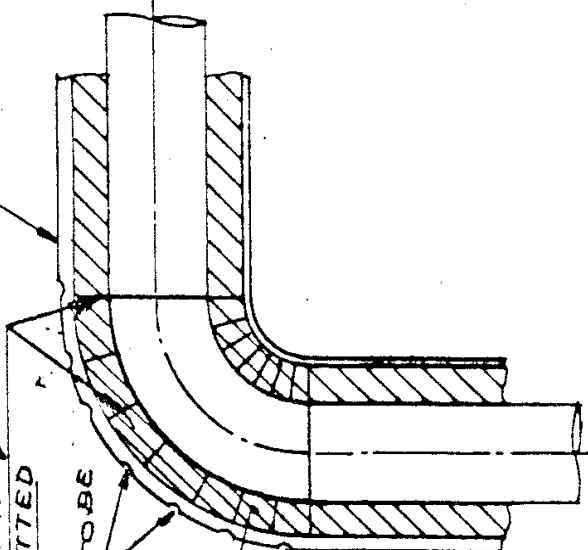

WITH MATTRESS

WORKED BY: - *Rigam*

CHECKED BY: - *Sharma*



**PRODUCT STANDARD
STEAM TURBINE ENGINEERING**

ST 29005

PAGE 20 OF 23

PIPE CLAMPS (ALLOY STEEL)

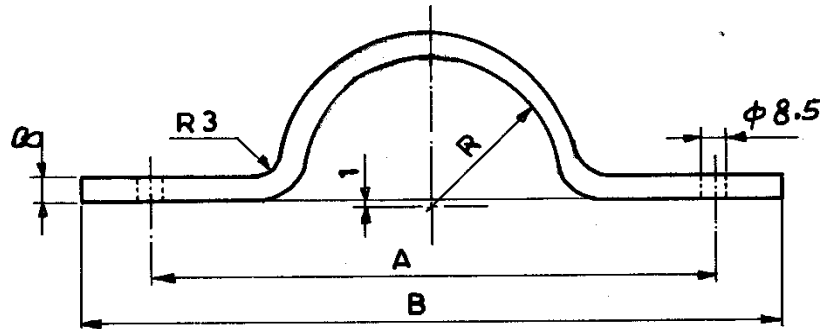

SIGN & DATE

SUPERSEDES INVENTORY No.

COPYRIGHT AND CONFIDENTIAL
The information on this document is the property of BHARAT HEAVY ELECTRICALS LIMITED. It must not be used directly or indirectly in any way detrimental to the interest of the company.

SIGN & DATE

INVENTORY NO.

VAR	A	B	R	NB	DESCRIPTION	MATL.SPCN.	UNIT WT.
01	76	91	30	50	PL. 8X50X125	13CrMo44	0.400
02	88	103	37	65	PL. 8X50X150	↑	0.480
03	183	198	84	150	PL. 8X50X295		0.920
04	234	249	110	200	PL. 8X50X380		1.200
05	288	303	137	250	PL. 8X50X460		1.450
06	371	306	178	350	PL. 8X50X590		1.850
07	421	436	203	400	PL. 8X50X670		2.100
08	473	488	229	450	PL. 8X50X752		2.400
09	523	538	254	500	PL. 8X50X824		2.600
10	626	644	305	600	PL. 8X50X990		3.000
11	123	138	54	100	PL. 8X50X200		0.630
12	129	144	57	100	PL. 8X50X210		0.660
13	174	189	80	150	PL. 8X50X282		0.900
14	339	354	162	300	PL. 8X50X540		1.700
15	365	380	175	350	PL. 8X50X580		1.820
16	569	584	280	550	PL. 8X50X910		2.860
17	104	119	44	80	PL. 8X50X166		0.520
18	156	171	70	125	PL. 8X50X248	↓	0.78
19	730	745	356	700	PL. 8X50X1150	13CrMo44	3.610

22/6/2019

P-5788

REV. NO. 04

WORKED BY:- *Rizwan*

CHECKED BY:- *[Signature]*



PRODUCT STANDARD
STEAM TURBINE ENGINEERING

ST 29005

PAGE 21 OF 23

SUPERSEDES INVENTORY No. SIGN & DATE

COPYRIGHT AND CONFIDENTIAL
The information on this document is the property of BHARAT HEAVY ELECTRICALS LIMITED. It must not be used directly or indirectly in any way detrimental to the interest of the company.

INVENTORY No. SIGN & DATE

P-5788

22/6/89

FIELD QUALITY PLAN :

SL NO	COMPONENT/ OPERATION	CHARACTERISTIC CHECKED	CAT	TYPE/ METHOD OF CHECK	EXTENT OF CHECK	REFERENCE DOCUMENT	ACCEPTANCE NORM	FORMAT OF RECORD	REMARKS
01	STORAGE AND HANDLING	Damage in transit and handling	MA	Visual	100%	Specif. & IS 10556	Specif. & IS 10556	Log Sheet	No breakage and damage of insulating materials. No distortion or tearing off the packing.
		Storage location	MA	-do-	-do-	-do-	-do-	-do-	Stacked under covered shed.
		Storage space and surroundings.	MA	-do-	-do-	-do-	-do-	-do-	Free from damp, oil, fume and sulphur bearing gases.
		Stacking height	MA	-do-	-do-	-do-	-do-	-do-	2 M. for pipe sections and 3 M. for mattresses.
		Platform	MA	-do-	-do-	-do-	-do-	-do-	Concrete or wooden.

Contd. on page 22

WORKED BY :- *Rigam*

CHECKED BY :- *[Signature]* REV. No. 04



PRODUCT STANDARD
STEAM TURBINE ENGINEERING

ST 29005

PAGE 22 OF 23

SIGN & DATE

SUPERSEDES
INVENTORY No.

COPYRIGHT AND CONFIDENTIAL
The information on this document is the property of BHARAT HEAVY ELECTRICALS LIMITED. It must not be used directly or indirectly in any way detrimental to the interest of the company.

FIELD QUALITY PLAN :-

SL NO	COMPONENT/ OPERATION	CHARACTERISTIC CHECKED	CAT	TYPE/ METHOD OF CHECK	EXTENT OF CHECK	REFERENCE DOCUMENT	ACCEPTANCE NORM	FORMAT OF RECORD	REMARKS
02	APPLICATION	Surface cleanliness	MA	Visual	Random	Specification	Specification	Log Sheet	Surface shall be free from dirt, rust, scale, oil etc. and dried.
		Insulation material appearance.	MA	-do-	-do-	-do-	-do-	-do-	Material shall be uniform and free from cracks, voids etc.
		Binding wires/ Bands spacing	MA	-do-	-do-	Appd. drg & specif.	Appd. drg & specif.	-do-	
		Wire netting dimensions and location.	MA	-do-	-do-	-do-	-do-	-do-	
		Wire ends	MA	-do-	-do-	-do-	-do-	-do-	Wire ends shall be twisted and bent inside.
		Supports arrangements & spacing	MA	-do-	-do-	-do-	-do-	-do-	
		Expansion joints spacing.	MA	-do-	-do-	-do-	-do-	-do-	
		Insulation thickness test	MA	Physical	10%	IS 7413 & Specf.	IS 7413 & Specf.	-do-	
		Uniformity of thickness	MA	-do-	-do-	-do-	-do-	-do-	
		Bulk density test	MA	-do-	-do-	-do-	-do-	-do-	

SIGN & DATE

m/6/89

INVENTORY No.

P-5788

Contd. on page 23

WORKED BY :- *Prigam*

REV. NO.
04

CHECKED BY :- *[Signature]*

SIGN & DATE

SUPERSEDES INVENTORY No.

COPYRIGHT AND CONFIDENTIAL
The information on this document is the property of BHARAT HEAVY ELECTRICALS LIMITED. It must not be used directly or indirectly in any way detrimental to the interest of the company.

SIGN & DATE

SIGN & DATE

INVENTORY No.



PRODUCT STANDARD
STEAM TURBINE ENGINEERING

ST 29005
PAGE 23 OF 23

FIELD QUALITY PLAN

SL NO	COMPONENT/ OPERATION	CHARACTERISTIC CHECKED	CAT	TYPE/ METHOD OF CHECK	EXTENT OF CHECK	REFERENCE DOCUMENT	ACCEPTANCE NORM	FORMAT OF RECORD	REMARKS	
03	FINISHING	Cladding material thickness	MA	Visual	Random	Appd. Drg & Specif.	Appd. Drg & Specif.	Log Sheet		
		ST Screws	MA	-do-	-do-	-do-	-do-	-do-		
		Grooving/ overlapping	MA	-do-	-do-	-do-	-do-	-do-		
		Joints Sealing	MA	-do-	-do-	-do-	-do-	-do-		
		Appearance	MA	-do-	-do-	-do-	-do-	-do-	Surfaces shall be uniform & free from cracks, dents etc.	
04	PERFORMANCE TESTING This shall be conducted after commissioning the plant.	Ambient temperat.	MA	Physical	10%	Specif.	Specif.	Log sheet	Shall be measured at a distance of 1 M from the insulation surface	
		Ambient air velocity	MA	-do-	-do-	-do-	-do-	-do-	-do-	-do-
		Cold face temperature	MA	-do-	-do-	-do-	-do-	-do-	-do-	Shall be measured at insulation cladding surface. This shall not be more than the specified value at the specified design conditions.

246789

1-5788

REV. NO. 04

WORKED BY: - *Rigam*

CHECKED BY: - *[Signature]*

MANUFACTURER'S NAME AND ADDRESS		STANDARD QUALITY PLAN		TO BE FILLED BY BHEL		TO BE FILLED BY BHEL				
VENDOR'S NAME AND ADDRESS		THERMAL INSULATION FOR TURBINE INTEGRAL PIPING		QP. NO.:	QA/BE/QP/316_Obra					
BHEL		DRG. NO.: 412114C5000 & 412114C5G01		REV. NO.:	00					
SPEC. NO.:		ST 29005		Page 1 of 2						
REV. NO.:		04								
SL. NO.	COMPONENT & OPERATIONS	CHARACTERISTICS	CLASS	TYPE OF CHECK	QUANTUM OF CHECK	REFERENCE DOCUMENT	ACCEPTANCE NORMS	FORMAT OF RECORDS	AGENCY	REMARKS
1	2	3	4	5	6	7	8	9	M B N	11

SL. NO.	COMPONENT & OPERATIONS	CHARACTERISTICS	CLASS	TYPE OF CHECK	QUANTUM OF CHECK	REFERENCE DOCUMENT	ACCEPTANCE NORMS	FORMAT OF RECORDS	AGENCY	REMARKS
1	2	3	4	5	6	7	8	9	M B N	11
1.0	Material									
1.0	Bonded mineral / Rockwell mattresses									
1.1	Routine tests									
1.1.1		Chemical Composition	Major	Chemical	1 Sample/lot	Vendor's Std IS 3144	Vendor's Std IS 8183	TC	P	-
1.1.2		Bulk Density	Major	Physical	Sample As Per IS 8183	IS 3144	IS 8183	TC	P	-
1.1.3		Recovery After Compression	Major	Physical	-do-	IS 8183	IS 8183	TC	P	-
1.1.4		Shot Content	Major	Chemical	-do-	IS 3144	IS 8183	TC	P	-
1.1.5		Moisture Content and Moisture Absorption	Major	Physical	-do-	IS 3144	IS 8183	TC	P	-
1.1.6		Incombustibility	Major	Thermal	-do-	IS 3144	IS 8183	TC	P	-
1.1.7		Thermal Conductivity or K-Value	Major	Thermal	Sample As Per IS 3144	IS 3346	IS 8183	TC	P	Refer Note:1
1.1.8		Sulphur Content	Major	Chemical	Sample As Per IS 8183	IS 3144	IS 8183	TC	P	-
1.1.9		Dimensional check	Major	Measurement	-do-	IS 3144	IS 8183	IR	P	-
1.1.10		Fibre Diameter	Major	Measurement	-do-	IS 3144	IS 8183	IR	P	-
1.1.11		Resistance to Vibration	Major	Physical	-do-	IS 3144	IS 8183	TC	P	-
1.1.12		Heat Resistance	Major	Physical	-do-	IS 3144	IS 8183	TC	P	-
1.1.13		Alkalinity	Major	Chemical	-do-	IS 3144	IS 8183	TC	P	-
1.1.14		Corrosive Attack / Chloride Content	Major	Chemical	-do-	IS 3144	IS 8183	TC	P	-
2.0	Sheathing Material- Aluminium Sheet									
2.1		Chemical Composition	Major	Analysis	Sample As Per IS 737	IS 737	IS 737	TC	P	-
2.2		Tensile Test & Elongation	Major	Physical	-do-	IS 737	IS 737	TC	P	-
2.3		Bend test	Major	Physical	-do-	IS 737	IS 737	TC	P	-
2.4		Gauging / Thickness	Major	Measurement	-do-	ST 29005	ST 29005 / Appd BOM	IR	P	-
3.0	Galvanised Steel / Stainless Steel Wire									Material correlation to be submitted along with

MANUFACTURER/SUBCONTRACTOR		FOR CUSTOMER USE		APPROVED BY	
NTRACTOR		LEGEND: ! RECORDS IDENTIFIED WITH (V) 'TICK' SHALL BE ESSENTIALLY INCLUDED BY CONTRACTOR IN QA DOCUMENTATION. M: MANUFACTURER / SUBCONTRACTOR B: BHEL / NOM: INSPECTION AGENCY N: CUSTOMER INDICATE 'P' PERFORM 'W' WITNESS AND 'V' VERIFICATION ALL 'W' INDICATED IN COLUMN 'N' SHALL BE 'CHP' OF CUSTOMER		30/9/2016 M. Chandra	

MANUFACTURER'S NAME AND ADDRESS		STANDARD QUALITY PLAN				TO BE FILLED BY BHEL		TO BE FILLED BY BHEL	
VENDOR'S NAME AND ADDRESS		ITEM		THERMAL INSULATION FOR TURBINE INTEGRAL PIPING		QP. NO.: QA/BE/QP/316_Obra			
BHEL		DRG. NO.: 412114C5000 & 412114C5001		REV. NO.: 00					
SL. NO.		COMPONENT & OPERATIONS		CHARACTERISTICS		CLASS		TYPE OF CHECK	
1		2		3		4		5	
				QUANTUM OF CHECK		REFERENCE DOCUMENT		ACCEPTANCE NORMS	
				6		7		8	
								FORMAT OF RECORDS	
								9	
								D	
								10	
								11	
								REMARKS	

SL. NO.	DESCRIPTION	CLASS	TYPE OF CHECK	QUANTUM OF CHECK	REFERENCE DOCUMENT	ACCEPTANCE NORMS	FORMAT OF RECORDS	AGENCY	REMARKS
3.1	for Netting, Binding, Stitching & Lacing	Major	Analysis	Sample As Per IS 6528 / IS 280	IS 6528/IS 280	IS 6528 / IS 280	TC	P	V -
3.2	Dimensions (Size of netting & Dia / Gauge of Wire)	Major	Measurement	-do-	ST 29005	ST 29005 / Appd BOM	IR	P	V -
3.3	Tensile Test & Elongation	Major	Physical	-do-	IS 6528/IS 280	IS 6528 / IS 280	TC	P	V -
3.4	Wrapping Test	Major	Physical	-do-	IS 6528/IS 280	IS 6528 / IS 280	TC	P	V -
3.5	Bend Test	Major	Physical	-do-	IS 6528 / IS 280	IS 6528 / IS 280	TC	P	V -
3.6	Mass of Coating for GI Wire	Major	Measurement	-do-	IS 280	IS 280	TC	P	V -
4.0	Straps, Bands & Screws								
4.1	Dimensional	Major	Measurement	--	ST 29005	ST 29005	COC	P	-
4.2	Visual	Major	Physical	--	ST 29005	ST 29005	COC	P	-
5.0	Corrosion Protection of Insulated surface								
5.1	Packing / Marking & Storage	Major	Visual	100%	ST 29005	ST 29005	IR	p	-
5.2	Packing & Despatch	Major	Visual	100%	ST 29005	ST 29005	IR	p	-

NOTE: 1. Thermal Conductivity or 'K' Value test report on the samples identified and tested in last one year shall be reviewed by BHEL / BHEL nominated inspection agency and: However samples for Thermal Conductivity or 'K' Value test shall be identified by BHEL / BHEL nominated inspection agency from each lot and test shall be conducted at CBRI Roorkee / IIT Chennai / PIBCO, NEW DELHI / M/s ISOLLOYD ENGINEERING TECHNOLOGIES LIMITED, BADDI. The test report of the same shall be submitted to BHEL for review and acceptance.

MANUFACTURER/SUBCONTRACTOR		FOR CUSTOMER USE	
NTRACTOR		APPROVED BY	
		<p>LEGEND: ! RECORDS IDENTIFIED WITH (V) 'TICK' SHALL BE ESSENTIALLY INCLUDED BY CONTRACTOR IN QA DOCUMENTATION M: MANUFACTURER / SUBCONTRACTOR B: BHEL / NOM. INSPECTION AGENCY N: CUSTOMER INDICATE 'P' PERFORM 'W' WITNESS AND 'V' VERIFICATION ALL 'W' INDICATED IN COLUMN 'N' SHALL BE 'CHP' OF CUSTOMER</p>	

Handwritten signature and date: 20/06/2016

