

Annexure-I

PRICE SCHEDULE FOR 02 TG SETS of NEVELI PROJECTS (2 X 500 MW) FOR FOREIGN SUPPLY (i.e. SUPPLY FROM OUT SIDE INDIA)				
SL NO.	DESCRIPTION OF ITEMS	TOTAL QTY (COL 3)	UNIT PRICE (ON FOB BASIS)	TOTAL PRICE (FOR QTY. IN COLUMN 3) FOB
1.	LP BY PASS STOP & CONTROL VALVE WITH EHAs	04 SETS		
2.	HYDRAULIC POWER SUPPLY UNIT (HPSU)	02 SETS		
3.	WATER INJECTION CONTROL VALVE WITH HYDRAULIC ACTUATOR	04 NOS.		
4.	FLOW NOZZLE FOR WIV	04 NOS.		
5.	TOOL KIT FOR LPBYPASS SYSTEM	01 SET		
6.	MANDATORY SPARES (As per drawing no. 3-12300-36113)	01 SET		
7.	COMMISSIONING SPARES as per BHEL Spec. drawing no. 3-12300-56005	02 SETS		
8.	SERVO VALVE (AS SPARES)	01 NO. OF EACH TYPE		
9.	SOLENOID VALVE (AS SPARES)	01 NO. OF EACH TYPE & MODULE		
10.	TOTAL FOB VALUE FOR THE SCOPE OF SUPPLY MENTIONED ABOVE.	02 TG SETs		
11.	SEA FREIGHT CHARGES UP TO MUMBAI FOR THE TOTAL SCOPE OF SUPPLY MENTIONED ABOVE.	02 TG SETs		
12.	"PER DAY" CHARGES FOR SUPERVISION OF ERECTION & COMMISSIONING AND TRAINING INCLUDING EVERY EXPENSE	--		
13.	"PER VISIT" CHARGES DURING SUPERVISION OF ERECTION & COMMISSIONIGN AND TRAINING INCLUDING EVERY EXPENSE	--		

- THE PRICES ARE TO BE SUBMITTED STRICTLY AS PER ABOVE PRICE SCHEDULE AND FOR THE SCOPE OF SUPPLY AS MENTIONED IN THE ENCLOSED DRAWINGS & SPECIFICATIONS, OTHER WISE THE OFFERS OF VENDORS MAY BE IGNORED.
- PRICE COMPARISON WILL BE DONE ON THE TOTAL LANDED COST TO BHEL TAKING ALL ITEMS & SERVICES TOGETHER.
- IN CASE OF SUPPLIES FROM FOREIGN COUNTRY (SUPPLIES FROM OUTSIDE INDIA) THE PRICES OF EACH AND EVERY ITEM, ARE TO BE QUOTED INCLUSIVE OF THIRD PARTY INSPECTION CHARGES (BY EITHER LLOYDS/BVQI/TUV).
- IN CASE SPECIAL TOOL & TACKLES ARE NOT OFFERED, THESE WILL HAVE TO BE SUPPLIED FREE OF COST, IF REQUIRED, AT ANY STAGE OF THE PROJECT IN FUTURE.
- **PERDAY AND PER VISIT CHARGES FOR SUPERVISION OF ERECTION & COMMISSIONIGN AND TRAINING ARE TO BE QUOTED IN THE PRICE SCHEDULE. FOR SUPERVISION OF ERECTION & COMMISSIONING AND TRAINING, 04 VISITS OF 22 MANDAYS (INCLUSIVE OF 02 DAYS FOR TRAINING) FOR 02 TG SETS WOULD BE TAKEN FOR THE PURPOSE OF EVALUATION. HOWEVER IN THE EVENT OF ORDERING, THE PAYMENT FOR SERVICES WILL BE MADE ON ACTUAL NUMBER OF DAYS / VISITS INVOLVED IN SUPERVISION OF ERECTION/ COMMISSIONING AND TRAINING.**
- SUPPLIER TO FURNISH THEIR TECHNICAL OFFERS IN TRIPLICATE FOR ALL THE ITEMS AS SPECIFIED IN THE SCOPE. ANY INFORMATION/CLARIFICATION TO AVOID ANY AMBIGUITY AT THE TIME OF EXECUTION OF THE CONTRACT MAY BE OBTAINED WELL IN ADVANCE BEFORE SUBMITTING THEIR TECHNICAL-CUM-PRICED OFFER.

Annexure-I

PRICE SCHEDULE FOR 02 TG SETS of NEYVELI PROJECTS (2 X 500 MW) FOR INDIGINOUS SUPPLY (i.e. IN INDIA)				
SL NO.	DESCRIPTION OF ITEMS	TOTAL QTY (COL 3)	UNIT PRICE (INR)	TOTAL PRICE (FOR QTY. IN COLUMN 3)
14.	LP BY PASS STOP & CONTROL VALVE WITH EHAs	04 SETS		
15.	HYDRAULIC POWER SUPPLY UNIT (HPSU)	02 SETS		
16.	WATER INJECTION CONTROL VALVE WITH HYDRAULIC ACTUATOR	04 NOS.		
17.	FLOW NOZZLE FOR WIV	04 NOS.		
18.	TOOL KIT FOR LPBYPASS SYSTEM	01 SET		
19.	MANDATORY SPARES (As per drawing no. 31230036113)	01 SET		
20.	COMMISSIONING SPARES as per BHEL Spec. drawing no. 3-12300-56005	02 SETS		
21.	SERVO VALVE (AS SPARES)	01 NO. OF EACH TYPE		
22.	SOLENOID VALVE (AS SPARES)	01 NO. OF EACH TYPE & MODULE		
23.	TOTAL VALUE FOR THE SCOPE OF SUPPLY MENTIONED ABOVE.	02 TG SETs		
24.	FREIGHT COST UP TO NEYVELI SITE	02 TG SETs		
25.	"PER DAY" CHARGES FOR SUPERVISION OF ERECTION & COMMISSIONING AND TRAINING INCLUDING EVERY EXPENSE.	--		
26.	"PER VISIT" CHARGES DURING SUPERVISION OF ERECTION & COMMISSIONIGN AND TRAINING INCLUDING EVERY EXPENSE	--		

- THE PRICES ARE TO BE SUBMITTED STRICTLY AS PER ABOVE PRICE SCHEDULE AND FOR THE SCOPE OF SUPPLY AS MENTIONED IN THE ENCLOSED DRAWINGS & SPECIFICATIONS, OTHER WISE THE OFFERS OF VENDORS MAY BE IGNORED.
- PRICE COMPARISON WILL BE DONE ON THE TOTAL LANDED COST TO BHEL TAKING ALL ITEMS & SERVICES TOGETHER.
- IN CASE SPECIAL TOOL & TACKLES ARE NOT OFFERED, THESE WILL HAVE TO BE SUPPLIED FREE OF COST, IF REQUIRED, AT ANY STAGE OF THE PROJECT IN FUTURE.
- **PERDAY AND PER VISIT CHARGES FOR SUPERVISION OF ERECTION & COMMISSIONIGN AND TRAINING ERECTION ARE TO BE QUOTED IN THE PRICE SCHEDULE. FOR SUPERVISION OF ERECTION & COMMISSIONING AND TRAINING, 04 VISITS OF 22 MANDAYS (INCLUSIVE OF 02 DAYS FOR TRAINING) FOR 02 TG SETS WOULD BE TAKEN FOR THE PURPOSE OF EVALUATION. HOWEVER IN THE EVENT OF ORDERING, THE PAYMENT FOR SERVICES WILL BE MADE ON ACTUAL NUMBER OF DAYS / VISITS INVOLVED IN SUPERVISION OF ERECTION/ COMMISSIONING AND TRAINING.**
- SUPPLIER TO FURNISH THEIR TECHNICAL OFFERS IN TRIPLICATE FOR ALL THE ITEMS AS SPECIFIED IN THE SCOPE. ANY INFORMATION/CLARIFICATION TO AVOID ANY AMBIGUITY AT THE TIME OF EXECUTION OF THE CONTRACT MAY BE OBTAINED WELL IN ADVANCE BEFORE SUBMITTING THEIR TECHNICAL-CUM-PRICED OFFER.

ANNEXURE-II**LP Bypass System - Check List for Documents to be submitted along with the offer**

Rev.02 Dt. 15.04.11

Sl.No.	Document details	Enclosed	
<i>A. Documents related to LP Bypass Valves & Actuators:</i>			
A.1	Overall general arrangement cross-sectional assembly drawing with all major dimensions required from layout point of view. Steam Inlet & Outlet weld edge sizes, bracket for valve suspension arrangement, location of center of gravity and total assembly weight has to be specified in the drawings. Bill of material (BOM) of the valve with actuator assembly has to be tabulated. Assembly & disassembly maintenance space dimensions shall be indicated in the drawings.	YES	NO
A.2	Separate Stop & Control Valve actuator drawings indicating therein the flange end connection detail, total actuator weight, overall dimension & dismantling space requirement. All items should be marked and listed in the BOM on the drawing itself. On the actuator drawings, schemes for Stop & Control valve actuator shall also to be shown schematically.	YES	NO
A.3	Sizing Calculation for bypass valves & actuators.	YES	NO
A.4	Data Sheets for LP bypass valve & actuators.	YES	NO
A.5	List of special tools (if any)	YES	NO
A.6	Valve characteristics		
(a)	Lift vs. Area ; Lift vs. Flow	YES	NO
(b)	Pressure vs. flow (upstream side/ down stream side)	YES	NO
A.7	Part list of valves & actuators.	YES	NO
<i>B. Documents related to HPSU:</i>			
B.1	Schematic circuit diagram showing connection of HPSU with respective bypass actuators & sizing calculation of HPSU & its main components.	YES	NO
B.2	General arrangement drawing of HPSU indicating therein the total assembly weight, overall major layout dimensions, foundation detail, space requirement for maintenance, flanges end connection detail and their material.	YES	NO
B.3	Schematic diagram duly indicated with all item nos., tag Nos. and legends. In this diagram, tank capacity, pump capacity of each CF Pumps, circulation pumps, rated power consumption of each pump motor, filtration rating of each filter and capacity of each Hydraulic Accumulators has to be specified.	YES	NO
B.4	Part list duly indicated with item no/Position No., quantity, catalogued/ drg. reference no. & source of procurement etc.	YES	NO
B.5	Data Sheet of HPSU alongwith wiring diagram.	YES	NO
<i>C. Documents related to Water injection control valve</i>			
C.1	Data sheets of valve & actuator indicating therein all parameters & material details.	YES	NO
C.2	General arrangement drawing of valve with actuator indicating therein major dimensions, dismantling dimensions & assembly weight. Bill of material must be tabulated on the assembly drawing.	YES	NO
C.3	Pneumatic/ Hydraulic actuator scheme (as applicable) indicating therein part numbers.	YES	NO
C.4	Part List of valve actuator		
C.5	Drawing for valve & actuator coupling arrangement.	YES	NO
C.6	Sizing calculation for valve & actuator.	YES	NO
C.7	Curve for water mass flow vs. % lift (indicating % lift at max. design water mass flow & min. controlled water mass flow).	YES	NO
C.8	Data sheets for all the items mounted on the control manifold.	YES	NO
C.9	Wiring diagram for electrical items.	YES	NO

<u>D. Documents related to C & I</u>			
D.1	Flow Nozzle data sheet as per ISO 5167	YES	NO
D.2	Flow Nozzle drawing	YES	NO
D.3	Flow Nozzle characteristic curve between differential pressure and flow (indicating calculation formula also)	YES	NO
D.4	List of Instruments (HPSU and Actuators) duly indicated with KKS Tag Nos., type, service, set points, range & make etc.	YES	NO
D.5	Feeder load list giving details of power supply, KW rating, current drawn etc. for various motors, fans and other electrical drives (including solenoid valves)	YES	NO
D.6	Valves Actuator Schematics	YES	NO
D.7	Positioner Details	YES	NO
<u>E. Documents related to all the offered equipments:</u>			
E.1	List of commissioning spares for all the offered equipments.	YES	NO
E.2	Priced list of recommended spares for future ordering.	YES	NO
E.3	Detailed 'Quality Plan' for the offered equipments. (As per clause no. 10.0 of ST 47050).	YES	NO
E.4	List of suppliers for major castings & forgings along with their respective quality plan.	YES	NO

MASTER LIST OF DOCUMENTS (MDL) OF LP BYPASS SYSTEM (STE-TG)

Rev.02 Dt.13.04.11

Sl. No.	Document	Remarks
<u>A. Documents to be submitted for BHEL reference prior to manufacturing:</u>		
1.	LP bypass valve sizing calculations	STE-TG
2.	Water injection valve sizing calculations	STE-TG
3.	LP bypass valve actuator selection sheet/sizing calculations	STE-TG
4.	Water injection valve actuator selection sheet/sizing calculations	STE-TG
5.	HPSU & its major component sizing calculations	STE-TG
<u>B. Documents to be submitted for BHEL approval prior to manufacturing:</u>		
1.	LPBP valve drawing, datasheet & bill of material	STE-TG
2.	WIV drawing, datasheet & bill of material	STE-TG
3.	HPSU GA drawing & bill of material	STE-TG
4.	HPSU schematics	STE-TG/CIE
5.	I & R Diagram system	STE-TG/CIE
6.	Steam blowing device & bill of material	STE-TG
7.	Details of Oil/FRF flushing device	STE-TG
8.	Flow nozzle datasheet as per ISO 5167	CIE
9.	Flow nozzle drawing	CIE
10.	Flow Nozzle characteristic curve between differential pressure and flow (indicating calculation formula also)	CIE
<u>C. Other documents to be submitted for BHEL approval :-</u>		
1.	LPBP valve actuator drawing & bill of material	STE-TG
2.	WIV actuator drawing & bill of material	STE-TG
3.	O & M manual	STE-TG
4.	Shipping/dispatch plan of the offered equipments including details of each boxes & sub boxes	STE-TG

Notes:

1. The vendor to submit the documents within 4 weeks from the data of placement of purchase order.
2. While submitting the documents the vendor to clearly mention the exceptions w.r.t. the documents already approved earlier by BHEL against similar projects.

ANNEXURE-IV

EQUIPMENT NAME

PROJECT NAME

VENDOR'S NAME

0009E-00Z1-3
DRAWING No.

DESCRIPTION	LAYOUT / PROCESS DATA				
Design Pressure (ata)	60				
Design Temp. (°C)	568				
Valve Diameter - DN	** - Supplier to specify				
Pressure Rating - PN	** - Supplier to specify				
Weld End connections Sizes -	AS PER BHEL DRG. No.3-12300-36200				
Type of Valve Connections -	Butt welded				
Valve Characteristics- Linear /Quadratic /Equal %	Linear				
Valve Type - Straight / Angle	ANGLE TYPE (SEE SH.NO.2)				
Hydraulic Medium - Mineral Oil / FRF for Actuation	FIRE RESISTANT FLUID (FRF)				
MATERIAL FOR VALVE CASING	A182 Gr:F91/ A217 Gr:C12A				
OPERATING REGIMES	CASE:1	CASE:2	CASE:3	CASE:4	CASE:5
Operating pressure at valve inlet P1 (ata)	24.78	20.00	12.00	12.30	42.78
Operating temp. at valve inlet T1 (°C)	565	480	325	420	565
Operating pressure at valve outlet P2(ata)	12.64	10.20	6.12	6.27	21.82
Steam flow per LP Bypass valve for various operating condition (Tonnes/hour)	518.95	305	200	310	688.14

TECHNICAL REQUIREMENTS :-

- Supplier to offer LP Bypass valves & their Actuators suiting to the input parameters as specified in the Table.
- All other technical requirements of the system not specified here shall be as per ST47050.
- All the technical data required as per ST47050 for the offered system shall be furnished by the supplier at the time of submission of the offer.
- Valve & actuators sizing calculations shall be done by supplier & to be furnished for BHEL review & approval. Valve sizing shall be done by the supplier for critical flow condition (i.e. P2=0.51XP1).
- Seat tightness shall be equivalent to block valve tightness confirming to MSS SP-61.
- FRF shall be used for actuation of actuators. It will be supplied by BHEL. Qty. needed for flushing of units and initial fill with topping up of one year shall be worked out by the vendor and informed with the offer. Also refer ST47050. The FRF shall be 100% trixylenyl phosphate (TXP) and as per any of the following brands.
a) Reloube Turbofluid 46XC or b) Fyrquel EHC-N
Vendor shall ensure compatibility of its actuators with these brands.
- All Valve internals subjected to steam flow shall be designed for design Pressure 60 ata, temp. 568°C & corresponding steam flow.
- 100% RT/UT & DPT/MPI for Valve casing shall be carried out by the vendor as per ANSI B-16.34. Test certificates for the same shall be furnished by the vendor for BHEL review.

NOTE:-

- FOR ANGLE TYPE OF LP BYPASS VALVE
-Stop Valve Actuator shall be : VERTICAL (STANDING)
-Control Valve Actuator shall be: HORIZONTAL

CASE1 : HP/LP BY PASS OPERATION
CASE2 : HOT START
CASE3 : COLD START
CASE4 : WARM START
CASE5 : VWO

MAT.CODE: W90312300158

Ref. Drawing No. _____
Sign & Date _____
Inventory No. _____

GRADE OF UNTOL. DIM
M/CG.- AA0230208 m
WELDING CLASS 'B' OF AA0621104
GAS CUTTING-TABLE 3 OF AA0621104

GMS No./		C B O M		STATUS OF DRG
AGREED DEPT	NAME	SIGN	DATE	

TYPE OF PRODUCT OR NAME OF CUSTOMER/PROJECT		STEAM TURBINE			
 BHARAT HEAVY ELECTRICALS LTD. RANIPUR, HARDWAR	DRN	VIJAY	-SD-	28.03.07	NO. OF VAR - 73 74
	CHD	AMIT	-SD-	28.03.07	
	APPD	R.GULATI	-SD-	28.03.07	
DEPT STE	SCALE	WEIGHT (KG)	REF. TO ASSY. DRG.	ITEM No.	NO. OF ITEMS
CODE 4011	NTS	-----	---	---	75 77
TITLE : LP BYPASS STOP & CONTROL VALVE WITH EHA		CARD CODE	DRAWING NO. 3-12300-36000		---
			SHEET No. 1		No. OF SHEETS 2

THIS DRG. SUPERSEDES THE OLD DRG. UNDER THE SAME NO. WITH CHANGES AS PER CHANGE ADVICE NO. STE-09-F0300.

CHANGED AS PER CHANGE ADVICE NO. STE-14-F0360.

CHANGED AS PER CHANGE ADVICE NO. STE-12-F0342.

COPYRIGHT AND CONFIDENTIAL

THE INFORMATION ON THIS DOCUMENT IS THE PROPERTY OF BHARAT HEAVY ELECTRICALS LIMITED. IT MUST NOT BE USED DIRECTLY OR INDIRECTLY IN ANY WAY DETERIMENTAL TO THE INTEREST OF THE COMPANY.

FIRST ANGLE PROJECTION

FORM DG 38(B)

DRAWING No. 3-12300-36000

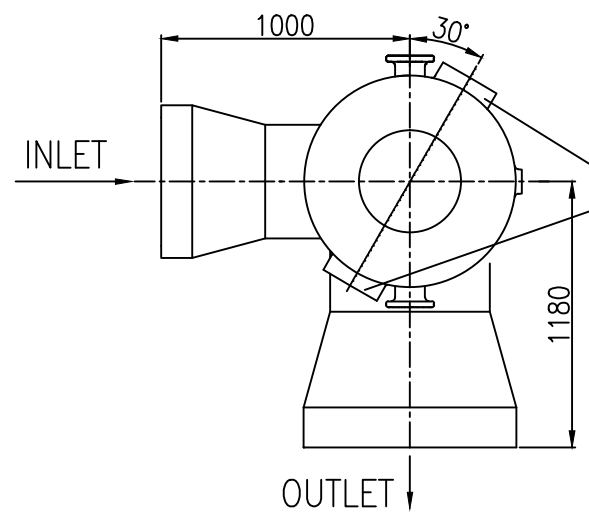

VIEW-Z
(WITHOUT ACTUATOR)

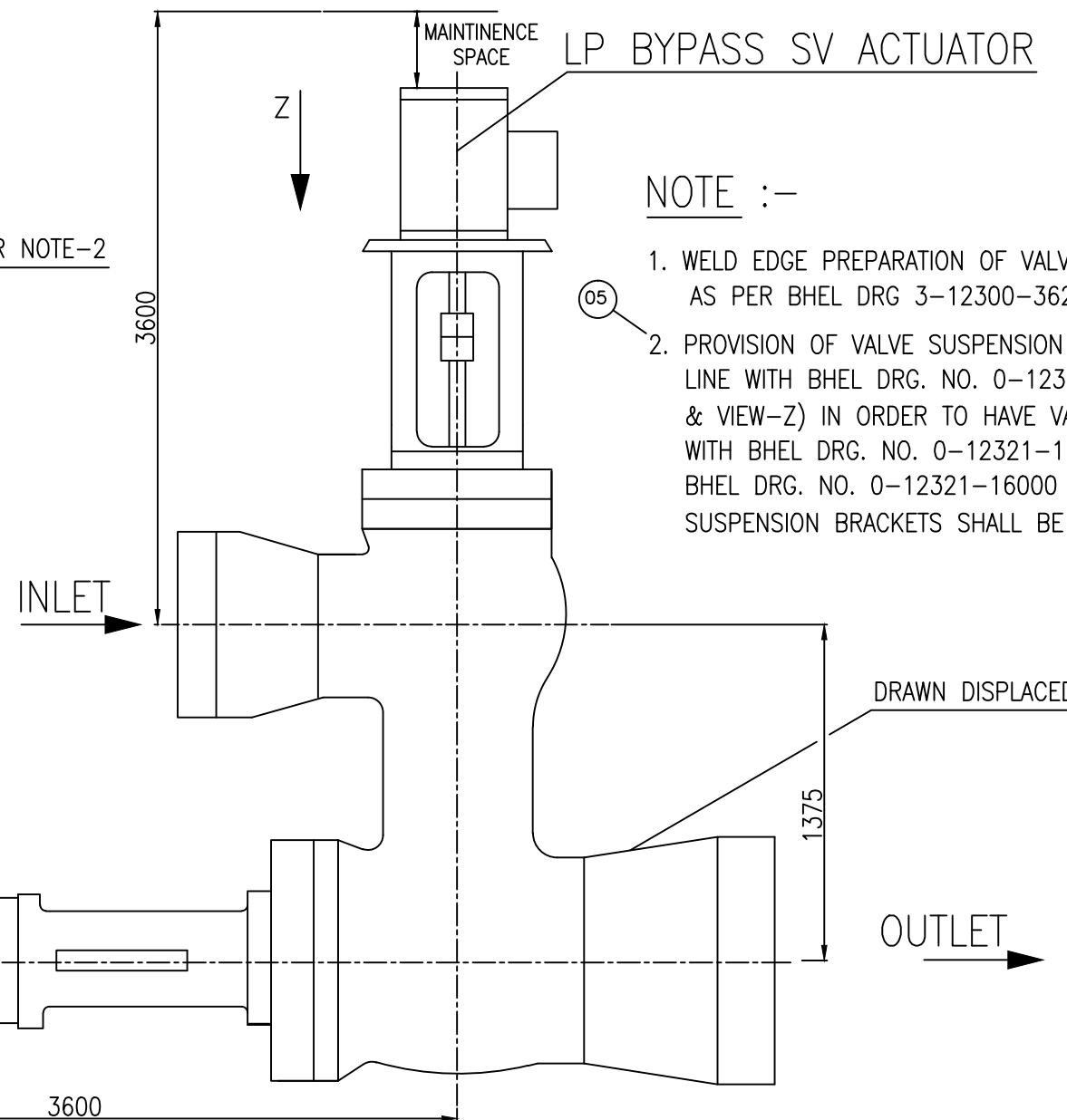

SCHEMATIC ARRANGEMENT OF ANGLE TYPE VALVE

NOTE :-

1. WELD EDGE PREPARATION OF VALVE INLET & OUTLET ENDS SHALL BE AS PER BHEL DRG 3-12300-36200.
2. PROVISION OF VALVE SUSPENSION SHALL BE KEPT BY THE VENDOR IN LINE WITH BHEL DRG. NO. 0-12303-25000 VAR.00 (REFER SECTION D-D & VIEW-Z) IN ORDER TO HAVE VALVE SUSPENSION ARRANGEMENT IN LINE WITH BHEL DRG. NO. 0-12321-16000. SUSPENSION OF VALVE AS PER BHEL DRG. NO. 0-12321-16000 SHALL BE IN BHEL SCOPE. MATERIAL OF SUSPENSION BRACKETS SHALL BE ASTM A182 Gr:F91 OR EQUIVALENT.

3-12300-46400
Ref.Drawing No>

Sign & Date

Inventory No.

GRADE OF UNTOL. DIM
M/CG.- AA0230208 m
WELDING-CLASS 'B' OF AA0621104
GAS CUTTING-TABLE 3 OF AA0621104

-GMS No./		C B O M		STATUS OF DRG
AGREED DEPT	NAME	SIGN	DATE	

TYPE OF PRODUCT OR NAME OF CUSTOMER/PROJECT
STEAM TURBINE

 **BHARAT HEAVY ELECTRICALS LTD.**
RANIPUR, HARDWAR

DRN	NAME	SIGN	DATE	NO. OF VAR
	VIJAY	-SD-	28.03.07	-
CHD	AMIT	-SD-	28.03.07	-
APPD	R.GULATI	-SD-	28.03.07	73 74

REV	DATE	ALTERED	REV	DATE	ALTERED	REV	DATE	ALTERED
		CHECKED	05	27.11.14	CHECKED	03	22.09.09	CHECKED
		UVERMA sd/-			VIKAS sd/-			VIKAS sd/-

DEPT STE
CODE 4011

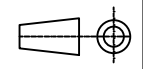

SCALE
NTS

WEIGHT (KG)
12000.00

REF. TO ASSY. DRG.
ITEM No. —

NO. OF ITEMS
75 77

CHANGED AS PER CHANGE ADVICE NO. STE-14-F0360.

THIS DRG. SUPERSEDES THE OLD DRG. UNDER THE SAME NO. WITH CHANGES AS PER CHANGE ADVICE NO. STE-09-F0300.

TITLE : LP BYPASS STOP & CONTROL VALVE WITH EHA

CARD CODE
DRAWING NO.
3-12300-36000

SHEET No. 2 No. OF SHEETS 2

SIZE A3

COPYRIGHT AND CONFIDENTIAL

THE INFORMATION ON THIS DOCUMENT IS THE PROPERTY OF BHARAT HEAVY ELECTRICALS LIMITED. IT MUST NOT BE USED DIRECTLY OR INDIRECTLY IN ANY WAY DETERIMENTAL TO THE INTEREST OF THE COMPANY.

FIRST ANGLE PROJECTION

(ALL DIMENSIONS ARE IN mm)

FORM DG 38(B)

3-12300-36200
DRAWING No.

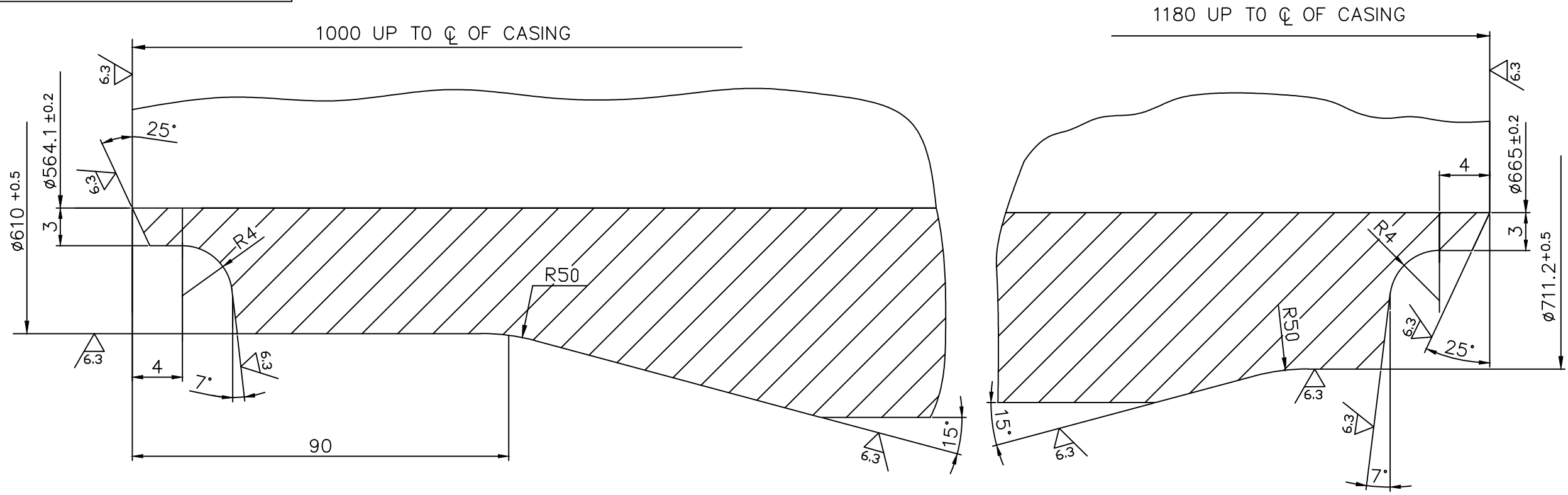

02
EDGE PREPARATION DETAIL AFTER HYDRAULIC TESTING
(STEAM INLET SIDE)
(PRELIMINARY)

02
EDGE PREPARATION DETAIL AFTER HYDRAULIC TESTING
(STEAM OUTLET SIDE)
(PRELIMINARY)

- 01 **TECHNICAL REQUIREMENTS:-**
- MATERIAL FOR WELD ENDS SHALL BE SA182Gr:F91.
 - WELD EDGE PREPARATION AT THE INLET AND OUTLET OF THE VALVE SHOWN IN THE DRAWING ARE PRELIMINARY AND SHALL BE CONFIRMED BY BHEL AFTER THE PLACEMENT OF FIRM ORDER.

STE-TC-033-GS
Ref. Drawing No.
Sign & Date
Inventory No.

GMS No./		C B O M		STATUS OF DRG	TYPE OF PRODUCT OR NAME OF CUSTOMER/PROJECT						
AGREED DEPT	NAME	SIGN	DATE		STEAM TURBINE						
GRADE OF UNTOL.DIM					BHARAT HEAVY ELECTRICALS LTD. RANIPUR, HARDWAR	DRN	NAME	SIGN	DATE	NO. OF VAR	
M/CG.-Ø/M/Ø AA0230208						CHD	VIJAY	-sd-	03.03.07		
WELDING-Ø/B/Ø/Ø AA0621104						APPD	AMIT	-sd-	03.03.07		
GAS CUTTING-'T3'AA0621101										73 74	
REV	DATE	ALTERED	REV	DATE	ALTERED	DEPT	SCALE	WEIGHT (KG)	REF. TO ASSY. DRG.	ITEM No.	NO. OF ITEMS
		CHECKED	02	24.09.08	sd/-	STE	N.T.S	-	-	-	-
		CHECKED	01	21.11.07	sd/-	4011					75 77
EDGE PREPARATION DETAIL AT STEAM INLET & OUTLET SIDE CHANGED AS PER C.A.NO. STE-08-F0282.					CHANGED AS PER C/A NO. STE-07-F0376		TITLE : EDGE PREPARATION DETAILS LPBV		CARD CODE	DRAWING NO. 3-12300-36200	
									7	22 23 24	
									SHEET No.01 No. OF SHEETS 01		

SIZE A3

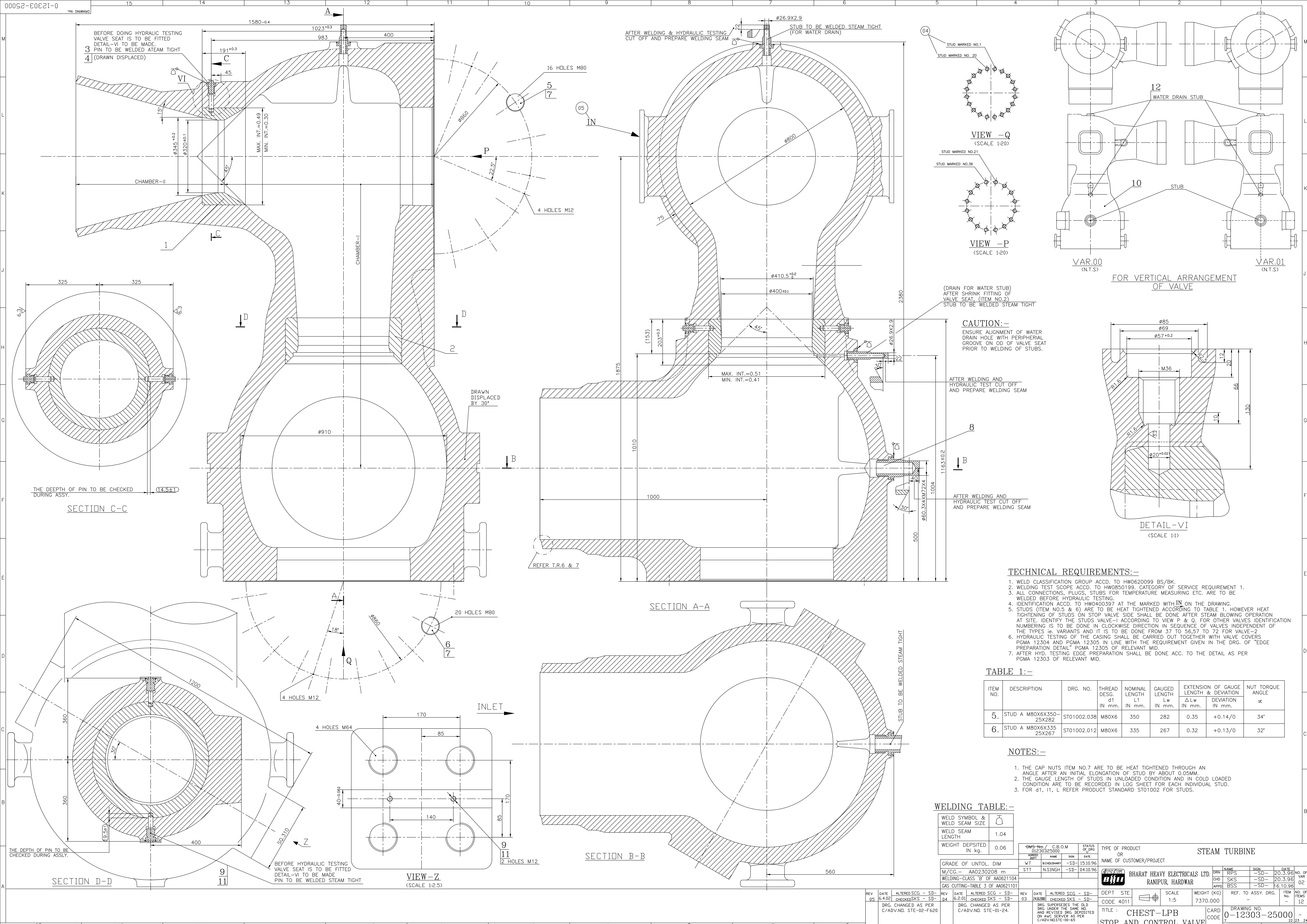

COPYRIGHT AND CONFIDENTIAL INFORMATION ON THIS DOCUMENT IS THE PROPERTY OF BHARAT HEAVY ELECTRICALS LIMITED. IT MUST NOT BE USED DIRECTLY OR INDIRECTLY IN ANY MANNER DETRIMENTAL TO THE INTERESTS OF THE COMPANY.

DRAWING No. 00052-30321-0

ITEM NO.	DESCRIPTION	DRG. NO.	THREAD DESG. d1 IN mm.	NOMINAL LENGTH L1 IN mm.	GAUGED LENGTH Lw IN mm.	EXTENSION OF GAUGE LENGTH & DEVIATION ΔLw IN mm.	DEVIATION IN mm.	NUT TORQUE ANGLE α
5.	STUD A M80X6350-25X282	ST01002.038	M80X6	350	282	0.35	+0.14/0	34°
6.	STUD A M80X6335-25X267	ST01002.012	M80X6	335	267	0.32	+0.13/0	32°

WELDING TABLE:-

WELD SYMBOL & WELD SEAM SIZE	
WELD SEAM LENGTH	1.04
WEIGHT DEPOSITED IN kg.	0.06

GRADE OF UNTOL. DIM M/CG.- AA0230208 m WELDING-CLASS 'B' OF A0621104 GAS CUTTING-TABLE 3 OF A0621101	TYPE OF PRODUCT OR NAME OF CUSTOMER/PROJECT STEAM TURBINE
DEPT STE CODE 4011	TITLE : CHEST-LPB STOP AND CONTROL VALVE
SCALE 1:5	WEIGHT (KG) 7370.000
REF. TO ASSY. DRG.	DRAWING NO. 0-12303-25000
CARD CODE 7	SHEET No. 01 No. OF SHEETS 24

00091-12321-0-12321-16000

COPYRIGHT AND CONFIDENTIAL INFORMATION ON THIS DOCUMENT IS THE PROPERTY OF BHARAT HEAVY ELECTRICALS LIMITED. IT MUST NOT BE REPRODUCED OR TRANSMITTED IN ANY FORM OR BY ANY MEANS, ELECTRONIC OR MECHANICAL, INCLUDING PHOTOCOPYING, RECORDING, OR BY ANY INFORMATION STORAGE AND RETRIEVAL SYSTEM.

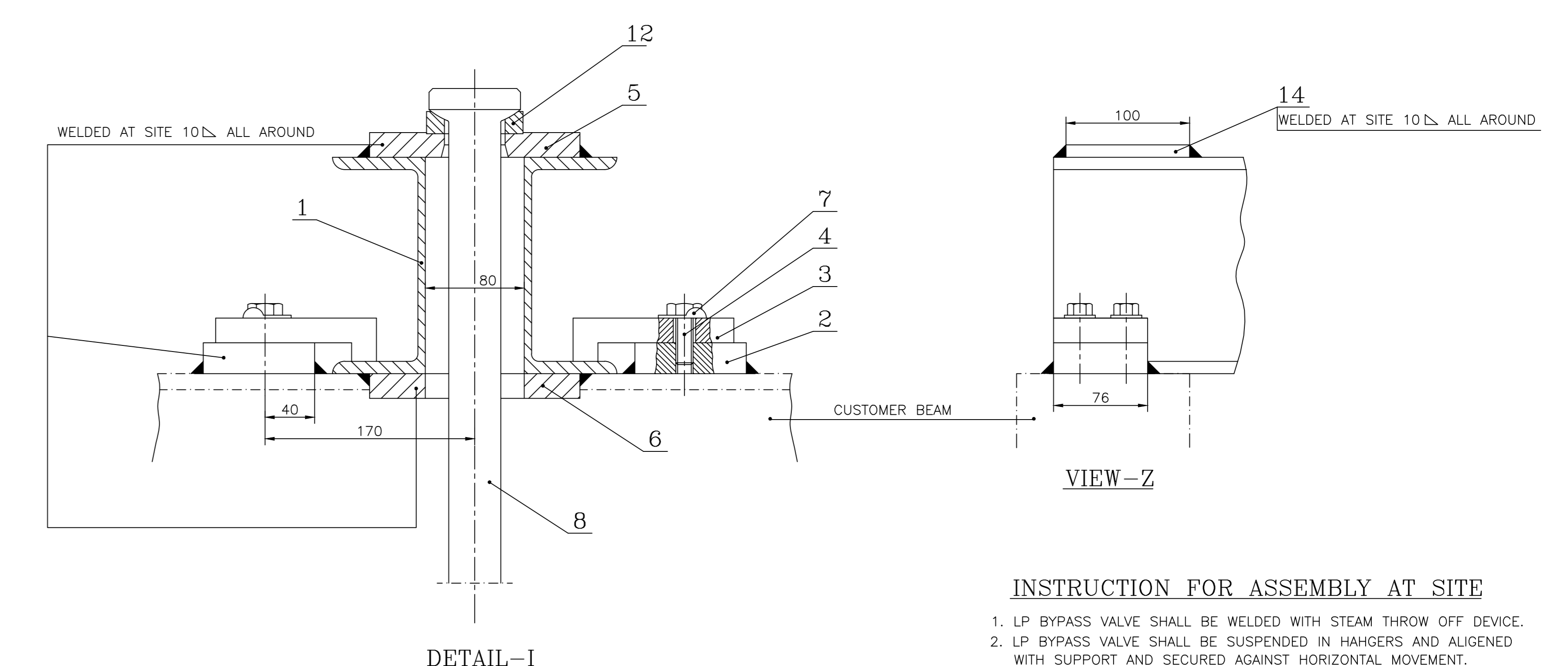
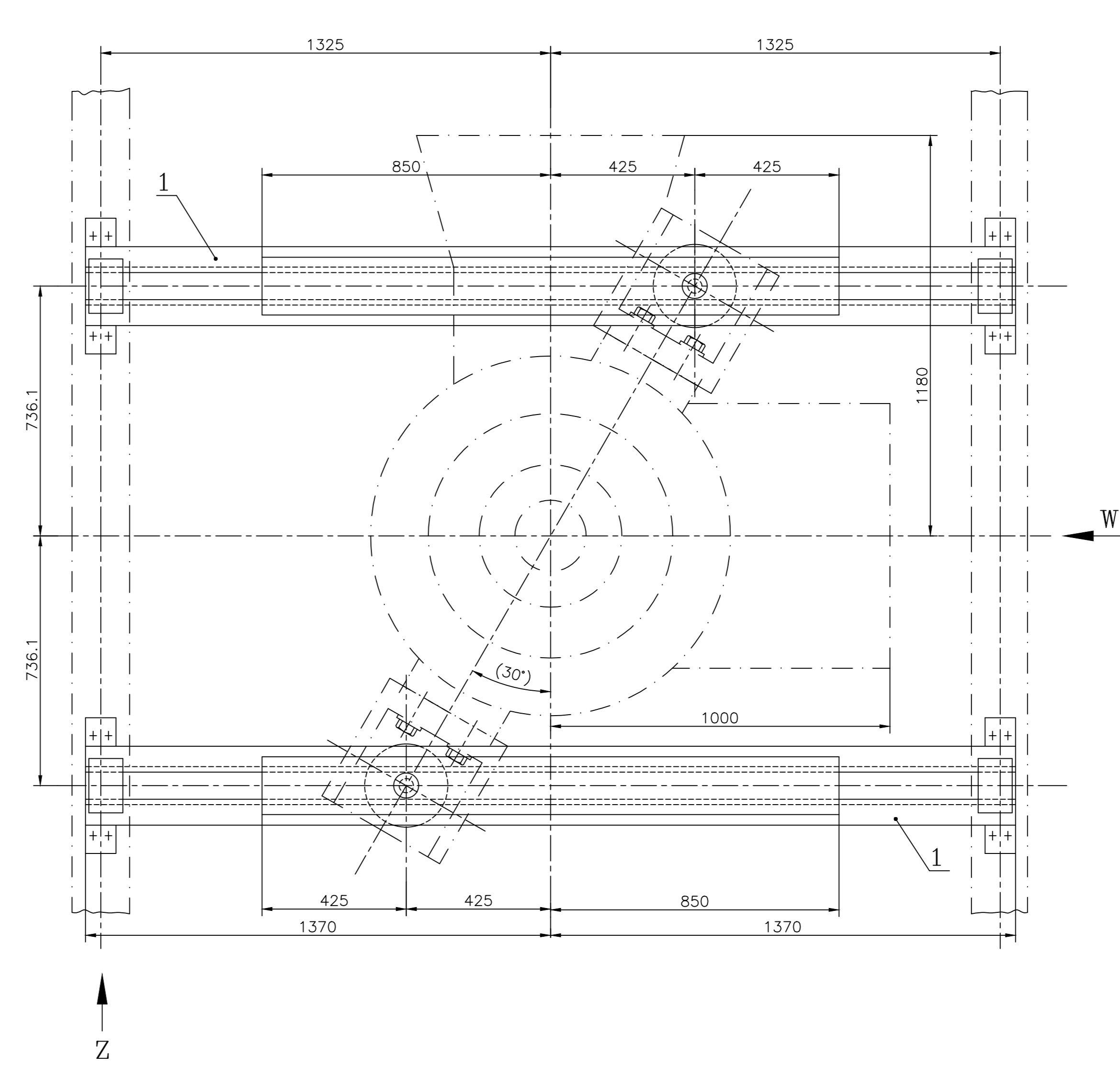
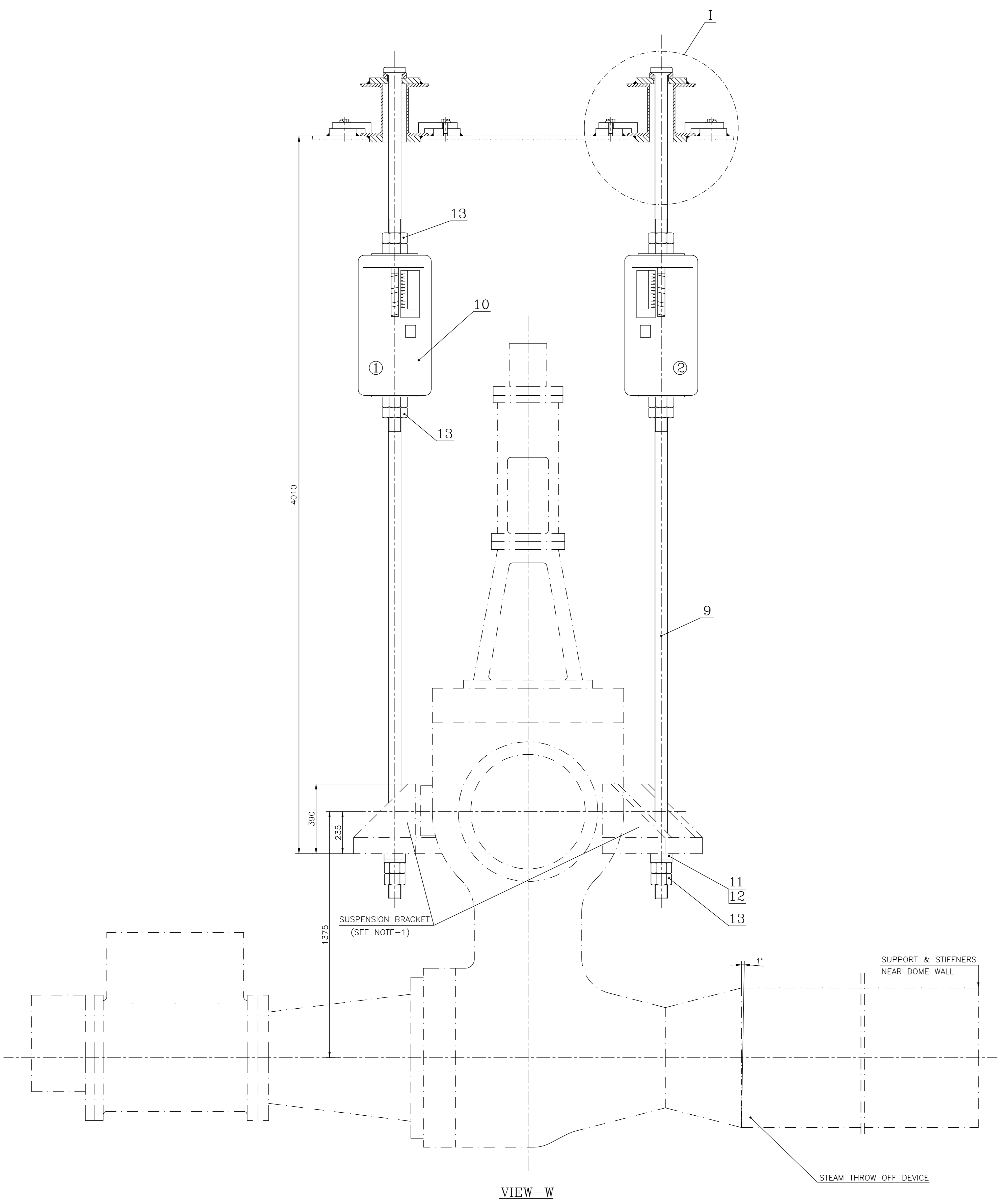





- INSTRUCTION FOR ASSEMBLY AT SITE**
1. LP BYPASS VALVE SHALL BE WELDED WITH STEAM THROW OFF DEVICE.
 2. LP BYPASS VALVE SHALL BE SUSPENDED IN HANGERS AND ALIGNED WITH SUPPORT AND SECURED AGAINST HORIZONTAL MOVEMENT.
 3. ADJUST ROD (ITEM 9) SO THAT BYPASS VALVE IS IN THE SPECIFIED POSITION.
 4. CLASSIFICATION OF WELD GROUP CK SHALL BE AS PER HW0620099.
 5. WELD TEST SCOPE SHALL CONFIRM TO HW0850199 WITH CATEGORY OF SERVICE REQUIREMENT AS 4.

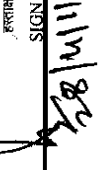

- TECHNICAL REQUIREMENTS**
1. ALL WASHERS ARE BENT ON TWO SIDES OF HEXAGON.
 2. SPRAY MOLYKOTE ON THREADED PARTS AND SLIDING SURFACES OF ITEM 11 & 12.



- NOTE:-**
1. SUSPENSION BRACKETS AS SHOWN SHALL ALSO BE SUPPLIED ALONG WITH LPBP VALVE BY THE VALVE SUPPLIER.
 2. INITIAL COMPRESSION OF SPRING HANGER = 26660N.
 3. SPRING CONSTANT = 533.3N/mm.

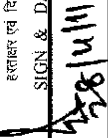
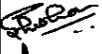
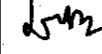

GRADE OF UNTOLDIM M/CG-E/W/F AAO230208		WELDING-K/B/E/B AAO21104		GAS CUTTING-T3 AAO621101																			
REV	DATE	ALTERED	CHECKED	REV	DATE	ALTERED	CHECKED	REV	DATE	ALTERED	CHECKED												
TYPE OF PRODUCT OR NAME OF CUSTOMER/PROJECT STEAM TURBINE			NAME OF CUSTOMER/PROJECT RANIPUR HARDWAR			DEPT CODE 4011			SCALE N.T.S			WEIGHT (KG) 986.00			REF. TO ASSY. DRG. -			ITEM NO. 014			NO. OF ITEMS -		
TITLE : SUSPENSION OF LPBP VALVE												DRAWING NO. 0-12321-16000			CARD CODE SHEET No. 01			No. OF SHEETS 01					



दिनांक एवं हस्ताक्षर SIGN & DATE		उत्पाद मानक PRODUCT STANDARD	ST 47050 पृष्ठ 28 का 2 Page 2 of 28			
सामग्री सूची संख्या को अधिकारित करता है	I TABLE OF CONTENTS					
COPYRIGHT AND CONFIDENTIAL The information on this document is the property of Bharat Heavy Electrical Limited. It must not be used directly or indirectly in any way detrimental to the interest of the company.	1.0 INTENT OF SPECIFICATION <ul style="list-style-type: none"> 1.1 Scope Of Contract 1.2 Responsibility of Bidder 1.3 Reliability & Provenness 2.0 FUNCTION					
	3.0 SCOPE OF SUPPLY					
स्वत्वाधिकार एवं गोपनीय इस प्रतीक में दी गई सूचना भारत हेवी इलेक्ट्रिकल्स की सम्पत्ति है इसका प्रकाश एवं आस्वादा रूप से किसी भी तरह प्रयोग, जो कि कंपनी के हित में हानिकारक हो न किया जाए ।	4.0 COMBINED LP BYPASS STOP & CONTROL VALVE: <ul style="list-style-type: none"> 4.1 Valve Sizing 4.2 Valve Connections (For Piping) 4.3 Valve Seat tightness 4.4 Drain & Warm-up Connections 4.5 Steam Strainer 4.6 Noise Level 4.7 General Valve Mounting Arrangement 4.8 Steam Blowing blanking arrangement 4.9 Other Requirements 5.0 INDIAN BOILER REGULATION					
हस्ताक्षर एवं दिनांक SIGN & DATE 	6.0 LP BYPASS STOP & CONTROL VALVE ACTUATORS <ul style="list-style-type: none"> 6.1 LP Bypass Stop & Control Valve Actuators Schemes (Proposed) <ul style="list-style-type: none"> 6.1.1 Position Measurement of Valves 6.2 Operating Time 6.3 Mounting Arrangement of Actuators <ul style="list-style-type: none"> 6.3.1 Mounting Arrangement of Control Block for Actuators 6.3.2 Actuator Control Fluid Connections 6.4 Control Fluid (CF) Specification 6.5 CF Pressure & Temperature 6.6 Control Fluid Tray for LP Bypass Valve Actuator (Vertically mounted) 7.0 HYDRAULIC POWER SUPPLY UNIT (HPSU) <ul style="list-style-type: none"> 7.1 Electrical Wiring <ul style="list-style-type: none"> 7.1.1 Instruments in HPSU 7.1.2 Interface with BHEL's system. 7.1.3 Power Supply 7.2 Coating, Cleaning & Preservation 					
सामग्री सूची संख्या INVENTORY NO. P-6301	REV. NO. 02		निर्माणकर्ता WORKED BY	SHUBHAM MITTAL		16.4.11
			जांचकर्ता CHECKED BY	R.C. AGARWAL		16.4.11

दिनांक एवं हस्ताक्षर SIGN & DATE		उत्पाद मानक PRODUCT STANDARD	ST 47050		
सामग्री सूची संख्या INVENTORY NO.	SUPERSEDES INVENTORY NO.	पृष्ठ 28 का 3 Page 3 of 28			
COPYRIGHT AND CONFIDENTIAL. The information on this documents is the property of Bharat Heavy Electricals Limited. It must not be used directly or indirectly in any way detrimental to the interest of the company.	<p>8.0 TOOLS & TACKLES</p> <p>9.0 MATERIAL & SURFACE PROTECTION</p> <p>9.1 Material Selection 9.2 Material Testing 9.3 Welding Material & Consumables 9.4 Welder Qualification</p> <p>10.0 FUNCTIONAL & TESTING REQUIREMENTS</p> <p>10.1 TEST CERTIFICATES</p> <p>11.0 SPARES</p> <p>11.1 Commissioning & Start-up Spares 11.2 Mandatory Spares 11.3 Recommended Spares 11.4 General Technical Requirements for Spares</p> <p>12.0 PROCESSING & DOCUMENTATION</p> <p>12.1 Processing Documents 12.2 Review Documents</p> <p>12.2.1 Documents Related to HPSU 12.2.2 Documents Related to LP Bypass Valves & Actuators 12.2.3 Documents Related to Water Injection Valves & Actuators 12.2.4 Other Documents Related to C&I.</p> <p>13.0 MARKING</p> <p>14.0 PACKING & TRANSPORTATION</p> <p>15.0 SUPERVISION DURING ERECTION- COMMISSIONING AND TRAINING AT SITE</p> <p>16.0 GUARANTEE</p> <p>17.0 PRICE</p> <p>18.0 LIST OF CROSS-REFERRED DOCUMENTS</p>				
स्वत्वाधिकार एवं गोपनीय इस दस्तावेज में दी गई सूचना भारत की इलेक्ट्रिकल्स की संपत्ति है इसका प्रत्यक्ष एवं अप्रत्यक्ष रूप से किसी भी तरह प्रयोग, जो कि कंपनी के हित में स्वत्वाधिकार को न नुकसान जाए।					
हस्ताक्षर एवं दिनांक SIGN & DATE 					
सामग्री सूची संख्या INVENTORY NO. P-6301	REV. NO. 02		निर्माणकर्ता WORKED BY	SHUBHAM MITTAL 	16.4.11
			जांचकर्ता CHECKED BY	R.C. AGARWAL 	16.4.11

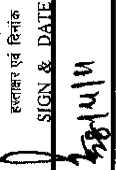

दिनांक एवं हस्ताक्षर SIGN & DATE		उत्पाद मानक PRODUCT STANDARD		ST 47050 पृष्ठ 28 का 4 Page 4 of 28				
सामग्री सूची संख्या को अधिकारित क्रमांक	SUPERSEDES INVENTORY NO.	II LIST OF APPENDICES TO THIS SPECIFICATION						
COPYRIGHT AND CONFIDENTIAL. The information on this documents is the property of Bhatat Heavy Electrical Limited. It must not be used directly or indirectly in any way detrimental to the interest of the company.		- GENERAL ARRANGEMENT OF LP BYPASS VALVES - - HYDRAULIC POWER SUPPLY UNIT FOR LP BYPASS SYSTEM - LP BYPASS STOP VALVE ACTUATOR SCHEME - - LP BYPASS CONTROL VALVE ACTUATOR SCHEME - - LP BYPASS VALVE (SINGLE STEM) ACTUATOR SCHEME - - MANUFACTURING QUALITY PLAN -		APPENDIX-1 APPENDIX-2 (TYPICAL) APPENDIX-3 (TYPICAL) APPENDIX-4 (TYPICAL) APPENDIX-5 (TYPICAL) APPENDIX-6, FORMAT-1				
	स्वत्साधिकार एवं गोपनीय इस प्रलेख में दी गई सूचना भारत हेवी इलेक्ट्रिकल्स की सम्पत्ति है इसका प्रयोग एवं प्रसारण के बिना ही तब तक प्रयोग, जो कि कंपनी के हित में प्रतिकारक हो न किया जाए।							
	हस्ताक्षर एवं दिनांक SIGN & DATE	28/11/11						
	सामग्री सूची संख्या INVENTORY NO.	P-6301	REV. NO: 02		निर्माणकर्ता WORKED BY	SHUBHAM MITTAL		16.4.11
					जांचकर्ता CHECKED BY	R.C. AGARWAL		16.4.11

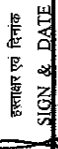

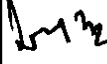
दिनांक एवं हस्ताक्षर SIGN & DATE		उत्पाद मानक PRODUCT STANDARD	ST 47050 पृष्ठ 28 का 5 Page 5 of 28			
शीर्षक एवं संख्या INVENTORY NO.	1.0 INTENT OF SPECIFICATION 1.1 Scope of Contract The Scope of the contract for the system shall be on the basis of the single point responsibility completely covering the following activities and services in respect of all the equipment covered under the specification. <ol style="list-style-type: none"> i. Detailed functional design, calculation, analysis & engineering of all equipment, systems, all type of spares, special tools for assembly & disassembly of various equipments & steam blowing devices. ii. Material Procurement. iii. Complete manufacturing including functional testing. iv. Providing engineering data, drawings for purchaser/owner's approval. v. Providing instruction manuals, as-built drawings, O & M manuals, safety instructions, waste disposal instructions of hydraulic medium etc. vi. Generation of quality/inspection reports indicating therein the complete test details and their acceptance norms i.e. test certificates indicating therein the chemical, physical & mechanical properties. These test certificates are to be provided as per mutually agreed Quality Plan. vii. Furnishing list of commissioning & recommended spares. viii. Seaworthy packing, preservation and transportation from the manufacturer's works to the nearest port for foreign supply; packing and supply ex-works basis for indigenous supply. ix. Supplier is to make provision that the equipments shall be capable for working continuously at an ambient temperature specified in the input data sheet. 					
COPYRIGHT AND CONFIDENTIAL The information on this documents is the property of Bharat Heavy Electrical Limited. It must not be used directly or indirectly in any way detrimental to the interest of the company.	Notes: <ol style="list-style-type: none"> i. No civil work relating to ground level is in bidder's scope. However, the foundation detail and necessary instructions, if any, in respect to locating of the centralized hydraulic supply unit from foundation point of view, has to be furnished by the bidder well in advance. This detail is required for finalization of the interface engineering activities. ii. Foundation bolts and fasteners for equipment fastening shall be in the bidder's scope. iii. Counter flanges along with fasteners & seals suiting to the end connections of actuators & HPSU shall be in bidder's scope. iv. In this bid specification, the company submitting the inquiry, namely 'BHARAT HEAVY ELECTRICALS LIMITED, HARDWAR, INDIA' is herein after referred to as "Purchaser" or "BHEL", the manufacturer tendering the bid is referred to as "Bidder", the bidder to whom contract is awarded to as "Supplier". 					
	स्वत्वधिकार एवं गोपनीय इस प्रलेख में दी गई सूचना भारत भारती इलेक्ट्रिकल लिमिटेड की संपत्ति है। इसका प्रयोग एवं आरक्षण का अधिकार केवल प्रदाता, जो कि कंपनी के हित में हस्ताक्षरकृत होना चाहिए।	1.2 Responsibility of bidder: 1.2.1 The bidder shall be responsible for providing all material, equipment and services, specified or otherwise which are required to complete the system and fulfill the intent of ensuring the successful operation, maintainability and the reliability of the complete work covered under this specification. It is not the intent to specify completely here in, all aspects of design and construction of equipment. Nevertheless, the equipment shall conform in all respects to high standards of engineering, design & workmanship & shall be capable of performing in continuous commercial operation, in a manner acceptable to Purchaser/owner.				
दिनांक एवं हस्ताक्षर SIGN & DATE 28/11/11	REV. NO. 02		निर्माणकर्ता WORKED BY	SHUBHAM MITTAL		16.4.11
शीर्षक एवं संख्या INVENTORY P-630/			जांचकर्ता CHECKED BY	R.C. AGARWAL		16.4.11

दिनांक एवं हस्ताक्षर SIGN & DATE		उत्पाद मानक PRODUCT STANDARD	ST 47050 पृष्ठ 28 का 6 Page 6 of 28	
सामग्री सूची संख्या को अधिकृतित करता SUPERSEDES INVENTORY NO.	<p>1.2.2 The bidder is requested to carefully examine and understand the specification prior to submitting the technical offer. Any deviation with respect to BHEL specifications shall be clearly identified in the offer & shall be submitted for BHEL review and approval. No deviation will be allowed after placement of order.</p> <p>1.2.3 The bidder shall furnish the filled up checklist of documents to ensure completeness of their offer.</p> <p>1.3 Reliability & Provenness:</p> <p>All equipments, components & accessories furnished against this specification shall be from the latest proven product range of the bidder. The satisfactory operation & high reliability of these equipments, components & accessories should have been fully established by a considerable record of successful operation. Purchased items shall be procured only from the proven suppliers & the list of all such items shall be furnished for BHEL review/ approval. The Major casting/ forging shall be procured from experienced vendors only. The vendor to submit list of vendors of major casting/ forgings incorporating their experience in last 5 years for the casting/ forgings of applicable material & weight (equal or higher) for BHEL review/approval.</p> <p>2.0 FUNCTION:</p> <p>During startup, shutdown due to load shedding or turbine trip out, and also at operations below minimum boiler load, the LP turbine cannot accommodate the entire volume of steam. The LP Bypass control system enables to establish an alternative path for dumping the excess steam into the condenser after de-superheating.</p> <p>3.0 SCOPE OF SUPPLY:</p> <p>3.1 The requirement is for LP Bypass Valves comprising of combined Stop & Control valves mounted in a single valve body with respective Electro-hydraulic Actuators and a centralized Hydraulic Power Supply Unit (HPSU). Water injection valve(s) with actuator(s), flow nozzle(s) for measuring water injection quantity are also envisaged in the supplier's scope. The specifications for water injection valve(s) and flow nozzle(s) are separately envisaged. Accessories for valves e.g. hydraulic test device, steam blowing devices, accessories for hydraulic system e.g. flushing device, filling & gauging device for hydraulic accumulator and manually operated control fluid pump for filling of fluid in control fluid tank of HPSU shall also be in the supplier's scope.</p> <p>Desuperheating of downstream steam and Fire Resistant Fluid (FRF) may be or may not be in supplier's scope. Such requirements are clarified in input data sheet enclosed with the specification.</p> <p>Scope of supply with regard to other requirements e.g. special tools & tackles, commissioning spares, mandatory spares, supervision during erection and commissioning, connecting pipe, dump tube etc. shall be as per the input data sheet.</p> <p>3.2 LP bypass valve with only one stem (single stem valve) is foreseen in some projects as per owner's requirements. In such cases, the valve is actuated for stop as well as control functions by its hydraulic actuator. This requirement is defined in the enclosed input data sheet.</p>			
COPYRIGHT AND CONFIDENTIAL The information on this documents is the property of Bharat Heavy Electrical Limited. It must not be used directly or indirectly in any way, detrimental to the interest of the company.				
स्वत्वाधिकार एवं गोपनीय इस दस्तावेज में दी गई सूचना भारत हेवी इलेक्ट्रिकल्स की सम्पत्ति है इस्तेमाल प्रत्यक्ष एवं अप्रत्यक्ष रूप से किसी भी तरह प्रयोग, जो कि कंपनी के हित में हानिकारक हो न किया जाए।				
दिनांक एवं हस्ताक्षर SIGN & DATE 				
सामग्री सूची संख्या INVENTORY NO. P-6301	REV. NO.02		निर्माणकर्ता WORKED BY SHUBHAM MITTAL 	16.4.11
			जांचकर्ता CHECKED BY R.C. AGARWAL 	16.4.11

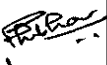

दिनांक एवं हस्ताक्षर SIGN & DATE		उत्पाद मानक PRODUCT STANDARD	ST 47050 पृष्ठ 28 का 7 Page 7 of 28			
सामग्री सूची संख्या का अधिकाधिकत करता	<p>4.0 COMBINED LP BYPASS STOP & CONTROL VALVE:</p> <p>Valves are to be designed to meet the requirements as stipulated in the input data sheet. The supplier shall ensure that LP bypass valve design shall be capable to withstand thermal shocks occurring during operations.</p> <p>4.1 Valve Sizing:</p> <p>Valve supplier will do the valve sizing calculation for critical flow based on steam parameters as indicated in the input data sheets and furnish the same for BHEL review and acceptance. The valve supplier shall also furnish the valve data sheets duly indicating therein the valve casing and valve stem material, steam forces, Cv value, valve stroke, opening and closing times etc. Valve manufacturer shall also furnish the Valve characteristics (<u>Flow vs. lift</u>).</p> <p>4.2 Valve Connections (For Piping) :</p> <p>Valve manufacturer shall also indicate the steam inlet & outlet connection sizes, material & the type of weld edge preparation inline with input data sheet for BHEL review and approval.</p> <p>4.3 Valve Seat Tightness :</p> <p>Seat tightness of LP bypass stop and control valves shall be equivalent to block valve tightness confirming to MSS-SP-61.</p> <p>4.4 Drain & Warm-up Connections:</p> <p>Location for warm-up Connection : To be provided at the lowest position of Stop Valve Location for Drain Connection : To be provided at the lowest position of Control Valve</p> <p>Drain connection size : Ø60.3X3.91 Warm-up connection size : Ø60.3X3.91</p> <p>The supplier shall furnish drain & warm-up connection Size, Material and Weld edge detail for BHEL review and approval.</p> <p>4.5 Steam Strainer:</p> <p>Steam strainer is to be provided on Stop valve side and it is not mandatory for Control Valve side. It should be installed inside the valve casing in such a way that it renders trouble free, reliable and safe service and is also easy to carryout maintenance. Valve manufacturer is to furnish the detailed sectional view drawing indicating therein the strainer material, fitting details and also specify the pressure drop across the strainer.</p> <p>4.6 Noise Level:</p> <p>Maximum Noise Level: 85dB (A) at a distance of 1 meter from the body.</p> <p>4.7 General Valve Mounting Arrangement:</p> <p>Type of valve arrangement shall be in accordance with the input data sheet. The valve may be suspended type or pipe mounted as specified in the input data sheet. A typical arrangement of</p>					
COPYRIGHT AND CONFIDENTIAL The information on this documents is the property of Bharat Heavy Electrical Limited. It must not be used directly or indirectly in any way detrimental to the interest of the company.						
स्वतंत्राधिकार एवं गोपनीय इस दस्तावेज में दी गई सूचना भारत हेवी इलेक्ट्रिकल्स की संपत्ति है इसका प्रयोग एवं आरक्षण इस से किसी भी तरह प्रयोग, जो कि कंपनी के हित में हानिकारक हो न किया जाए ।						
हस्ताक्षर एवं दिनांक SIGN & DATE  28/11/14						
सामग्री सूची संख्या INVENTORY NO. P-6301	REV. NO. 02		निर्माणकर्ता WORKED BY	SHUBHAM MITTAL		16.4.11
			जांचकर्ता CHECKED BY	R.C. AGARWAL		16.4.11

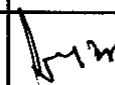

SIGN & DATE		उत्पाद मानक		ST 47050	
		PRODUCT STANDARD		पृष्ठ 28 का 8 Page 8 of 28	
SUPERSEDES INVENTORY NO.	संश्लेषित संख्या को अधिकतम करें	vertically suspended valve is shown in the Appendix-1 .			
<p>COPYRIGHT AND CONFIDENTIAL The information on this document is the property of Bharat Heavy Electrical Limited. It must not be used directly or indirectly in any way detrimental to the interest of the company.</p>		<p>Valve manufacturer shall provide the valve support paws/brackets, which may be welded or integrally cast or fastened to the valve body. Details of the valve support paws/bracket shall be furnished at the time of offer. <i>In case of suspended type valve, frame for valve suspension and valve suspension arrangement shall be in BHEL scope.</i> Valve manufacturer shall furnish the General Arrangement drawing duly indicating therein the overall assembly dimensions, actuators dismantling space, total weight & must show the location of actuator oil connection and C.G (Center of Gravity) of the complete assembly.</p>			
<p>स्वसाधिका एवं गोपनीय इस प्रलेख में दी गई सूचना भारत हेवी इलेक्ट्रिकल्स की संपत्ति है, प्रकटा प्रलेख एवं अवलोकन रूप से किसी भी तरह प्रयोग, जो कि कंपनी के हित में हानिकारक हो न किया जाए।</p>		<p>4.8 Steam Blowing blanking arrangement: Steam blowing of steam inlet pipes is done before putting the valves in actual operation. Valve supplier shall also supply one no. Steam blowing blanking arrangement per LP Bypass valves per Steam Turbine unit along with the main equipment and furnish the blanking arrangement drawing for review.</p> <p>4.9 Other Requirements: The supplier to furnish leakage flow quantity through glands of stop & control valve for which pressure of 0.5 bar may be considered at the downstream. Size & material of the weld end for leakage flow connections shall be furnished. In case no leakage from valve glands for stop and control valve are foreseen in the design, specific confirmation for this shall be given in the offer.</p> <p>5.0 INDIAN BOILER REGULATION: LP Bypass valves covered under this specification fall under the purview of Indian Boiler Regulation (IBR) and hence must satisfy all the conditions of IBR and the test certificate in IBR form III-C counter signed by an independent inspecting agency/authority approved by Indian Boiler Board shall be required. Assembly drawings of LP bypass valve shall be duly approved/countersigned by the IBR approved inspecting agency/authority.</p> <p>6.0 LP BYPASS STOP & CONTROL VALVE ACTUATORS:</p> <p>6.1 LP Bypass Stop & Control Valve Actuators Schemes (Proposed):</p> <p>a) Sizing of actuators and all other elements such as Filters, Cartridge valves, check valves and throttle orifices etc. mounted on the control manifold of the respective actuators is in the supplier's scope. Servo-valves for control valve actuators shall act as an interface between the actuators and BHEL's control system, which shall position the control valves as per system requirement. The vendor may offer Servo-valve/ proportional valve as per their standard practice. The design of the Control Valve Actuator shall be such that in case of interruption of CF supply or the electrical signal, the LP bypass control valve shall remain "IN PLACE" during failure mode. For quick closing of stop valves, 2 nos. solenoid operated Poppet valves (TSV's) shall be supplied. Solenoid shall be with single / double coils as per supplier's standard practice and operation of coil(s) (simultaneous operation on both coils in case of double coils) of any one</p>			
INVENTORY NO.	संश्लेषित एवं दिनांक	REV. NO. 02	निर्माणकर्ता	SHUBHAM MITTAL	16.4.11
P-6301	28/11/11		जांचकर्ता	R.C. AGARWAL	16.4.11

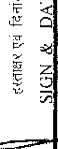
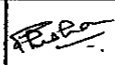
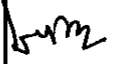
दिनांक एवं हस्ताक्षर SIGN & DATE		उत्पाद मानक PRODUCT STANDARD	ST 47050 पृष्ठ 28 का 9 Page 9 of 28		
शपथी सूची संख्या INVENTORY NO.	<p>TSV should affect trip. The Trip Solenoid valves shall be connected to protection system supplied by BHEL. All Solenoid Valves (Pilot Valves and TSVs) shall be rated for 25V±5V. All the valve actuators shall be capable of operating at 60°C control fluid temperature continuously.</p> <p>Refer proposed actuator schemes as per enclosed Appendix-3 & 4. However, Supplier will prepare their own schemes and submit the same for BHEL review and approval.</p> <p>b) In case of LP bypass valve with one actuator (Single stem valve), the applicable scheme as per Supplier's standard practice shall be submitted for BHEL review & approval. However a typical scheme is attached as per Appendix-5.</p> <p>c) All filters of actuators shall be equipped with differential pressure switches for alarm along with local indication for clogging.</p> <p>6.1.1 Position Measurement of Valves:</p> <p>Each Stop Valve Actuator should be equipped with 4 Limit Switches (i.e. 2 for Open & 2 for Close position). Limit Switches shall be of mechanical type. Each Control Valve actuator should be equipped with non-contact type position transmitter for measuring the position of the Control valve. Details of the same shall be furnished along with the offer. The output of the Position Transmitter shall be 4 mA (valve fully closed) to 20mA (valve fully opened).</p> <p>6.2 Operating Time:</p> <p>(a) For LP bypass stop & control valve (Double stem):</p> <p>(i) LP Bypass Stop Valve Actuator:</p> <p style="margin-left: 40px;">Opening time : < 2 Seconds for full stroke (Against spring force)</p> <p style="margin-left: 40px;">Closing time : = 1±10% Seconds for full stroke (With spring force)</p> <p>(ii) LP Bypass Control Valve Actuator:</p> <p style="margin-left: 40px;">Opening time : < 2 Seconds for full stroke</p> <p style="margin-left: 40px;">Closing time : < 2 Seconds for full stroke</p> <p>(b) For LP bypass valve (Single stem):</p> <p style="margin-left: 40px;">In case of single stem valve actuator, the operating time shall be as follows:</p> <p style="margin-left: 80px;">Opening time : < 2 Seconds for full stroke (Against spring force)</p> <p style="margin-left: 80px;">Closing time : = 1±10% Seconds for full stroke (For emergency closure)</p> <p style="margin-left: 80px;">Closing time : < 2 Seconds for full stroke (For modulating control)</p> <p>To adjust the opening and closing time of actuators, throttle orifices shall be provided wherever necessary.</p>				
COPYRIGHT AND CONFIDENTIAL. The information on this documents is the property of Bharat Heavy Electrical Limited. It must not be used directly or indirectly, in any way, detrimental to the interest of the company.					
	स्वत्वधिकार एवं गोपनीय अप्राप्त कृत्यों को सुरक्षित रखें। इस दस्तावेज़ में उल्लिखित जानकारी को बिना अनुमति के किसी भी तृतीय पक्ष को देना या प्रकट करना गैर-मंजूर है।				
दिनांक एवं हस्ताक्षर SIGN & DATE 28/11/11					
शपथी सूची संख्या INVENTORY NO. P-6301	REV. NO.02		निर्माणकर्ता WORKED BY SHUBHAM MITTAL		16.4.11
			जांचकर्ता CHECKED BY R.C. AGARWAL		16.4.11

निमांक एवं तिथि SIGN & DATE		उत्पाद मानक PRODUCT STANDARD	ST 47050		
SUPERSEDES INVENTORY NO सामग्री सूची संख्या को अतिरिक्त/पिछे को	<p>6.3 Mounting Arrangement of Actuators:</p> <p>Type of arrangement required is specifically mentioned in the input data sheet.</p> <p>A typical arrangement of LP Bypass valve is shown in Appendix-1 for straight type of valves for which orientation of actuators shall be as follows:</p> <ul style="list-style-type: none"> - Stop Valve Actuator : Vertical (Standing) - Control Valve Actuator : Vertical (Hanging) <p>Incase of Angle type of valve arrangement, the Stop valve and Control Valve actuators shall be perpendicular to each other respectively. Supplier is to ensure & make provision for proper venting in the actuators for such angle type of valve arrangement.</p> <p>6.3.1 Mounting Arrangement of Control Block for Actuators:</p> <p>The Control Block for each actuator shall be mounted on the Power Cylinder. EHA supplier shall ensure that supply and return line connections shall preferably be on the same side of the actuators as shown in the enclosed sketch (Appendix-1).</p> <p>6.3.2 Actuator Control Fluid Connections:</p> <p>Supplier will ensure the flange end connections of supply & return pipelines as per sizes given below:</p> <ul style="list-style-type: none"> - Supply Pipeline : Ø26.7X3.91, Material as per ASTM A312, GradeTP321 - Return Pipeline : Ø33.4X2.6, Material as per ASTM A312, GradeTP321 <p>If the actuating medium used is MINERAL OIL of viscosity class as per ISOVG100 according to DIN51519 then supplier shall also make a provision for guarded pipeline connection as per size given below:</p> <ul style="list-style-type: none"> - Guarded Pipeline : Ø88.9X5.49, Material Carbon Steel 				
COPYRIGHT AND CONFIDENTIAL. The information on this documents is the property of Bharat Heavy Electrical Limited. It must not be used directly or indirectly in any way detrimental to the interest of the company.	<p>6.4 Control Fluid (CF) Specification:</p> <p>(a) The Electro-hydraulic actuation (EHA) system shall be designed suiting to the control fluid medium as specified in the input data sheet. Total control fluid quantity comprising of quantities required for regular bypass system operation + flushing of the complete EHA system + sufficient quantity for one year make-up shall be worked out by the EHA supplier and informed to BHEL at the time of offer.</p> <p>(b) If specified in the input data sheet control fluid of required quantity shall be supplied by the supplier. The supplier shall furnish the specification and source of procurement for BHEL review and approval.</p>				
	स्वात्वाधिकार एवं गोपनीय इस प्रलेख में की गई सूचना भारत हेवी इलेक्ट्रिकल्स लिमिटेड की संपत्ति है इसका प्रयोग एवं आभार के बिना किसी भी तरह प्रयोग, को बिना लिखित अनुमति के, बिना की जाये।				
निमांक एवं तिथि SIGN & DATE 28/11/11					
सामग्री सूची संख्या INVENTORY NO P-6301	REV. NO.02		निमांककर्ता WORKED BY SHUBHAM MITTAL		16.4.11
			जांचकर्ता CHECKED BY R.C. AGARWAL		16.4.11

दिनांक व हस्ताक्षर SIGN & DATE		उत्पाद मानक PRODUCT STANDARD	ST 47050		
सुपरसेडिंग्स INVENTORY NO.	शीर्षक संख्या को अतिरिक्त प्रवेश	<p>6.5 CF Pressure & Temperature:</p> <ul style="list-style-type: none"> - Normal operating pressure - 160 bar - Minimum operating pressure - 115 bar - Normal Control Fluid temperature - 50+5°C - Maximum Control Fluid temperature - 75°C <p>6.6 Control Fluid Tray for LP Bypass Valve Actuator (Vertically mounted):</p> <p>CF tray shall be provided to prevent CF falling on valve body in case of leakage & CF sensor shall also be provided in the CF tray to detect leakage for indication in control room.</p> <p>7.0 HYDRAULIC POWER SUPPLY UNIT (HPSU): (Refer Appendix-2, Proposed)</p> <p>The Hydraulic Power Supply Unit (HPSU) is required for actuation of LP Bypass Stop & Control Valve Actuators and water injection valve actuator(s) (if hydraulically actuated water injection valve(s) are envisaged in applicable specification). The EHA supplier, suiting to the control medium as specified in the input data sheet, shall do the design & sizing of HPSU. HPSU will consist of all necessary components like CF pumps, filters, hydraulic accumulators, check valves, pressure & temperature measuring instruments, Level measuring instruments, filtration-cum-cooling unit and regeneration unit for Control Fluid (CF) purification.</p> <p>Supplier to ensure that all the surfaces coming in contact with control fluid including control fluid tank shall be made of stainless steel.</p> <p>The Control fluid (CF) tank shall be adequately sized to accommodate total system quantity of fluid including fluid contained in pressure lines, return lines, actuators & hydraulic accumulators etc. Suitable provision for vapor extraction shall be provided by the supplier in the CF tank.</p> <p>Two nos. CF Pumps shall be provided in the CF tank with their pressure and flow control valves and shall be immersed into the CF medium in the CF tank. The electric motors of CF pumps and the pressure control valves for system pressure adjustment shall be mounted on the CF tank cover. Two CF pumps are required in the HPSU, one of that can be pre-selected for operation, whereas the other shall act as standby, operation of which shall be automatically switched over in case of any fault. Changeover of pumps shall take place depending on the CF pressure as well as outage of the working pump motor. Control of Pumps & cooling circuit will be realized in BHEL's control system. Pumps are to be designed by the HPSU supplier as pressure-controlled pumps, which shall maintain the constant pressure to a constant preset value i.e. 160bar and shall regulate the CF quantity according to the demand. Pressure surges/pulsations are required to be dampened by bladder type hydraulic accumulators, which will also ensure that the system pressure does not collapse. Accumulators shall ensure positive supply of oil to hydraulic actuators even when hydraulic oil pumps are not available. Accumulators shall be adequately sized to ensure supply for at least two complete stroking operations of all connected actuators. Sizing of the accumulators shall be done by the HPSU supplier and supplier shall decide the quantity & capacity of accumulators for reliable operation of the actuators.</p>	पृष्ठ 28 का 11 Page 11 of 28		
COPYRIGHT AND CONFIDENTIAL. The information on this document is the property of Bharat Heavy Electrical Limited. It must not be used directly or indirectly, in any way, detrimental to the interest of the company.					
स्वत्वाधिकार एवं गोपनीय इस दस्तावेज में दी गई सूचना भारत हेवी इलेक्ट्रिकल्स की संपत्ति है। इसका प्रयोग एवं अप्रत्यक्ष रूप से किसी भी तरह प्रयोग, जो कि कंपनी के हित में हितकारक हो सकता है।					
दिनांक व हस्ताक्षर SIGN & DATE	 28/11/11				
शीर्षक संख्या INVENTORY	P-6301	REV. NO. 02	निर्माणकर्ता WORKED BY	SHUBHAM MITTAL 	16.4.11
जांचकर्ता CHECKED BY			जांचकर्ता CHECKED BY	R.C. AGARWAL 	16.4.11

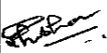
दिनांक एवं हस्ताक्षर SIGN & DATE		उत्पाद मानक PRODUCT STANDARD	ST 47050 पृष्ठ 28 का 12 Page 12 of 28	
सामग्री सूची संख्या के अधिकाधिकार कठोरता	SUPERSEDES INVENTORY NO.	<p>Two nos. separate cooling-cum-filtration circuits (filtration rate of return line filters is 3μ absolute) shall be provided in order to maintain the cleanliness of the system and to ensure proper cooling. Separate AC driven circulation pumps with 2X100% capacity shall be provided to pump CF into these circuits. 2X100% coolers shall be provided for cooling of CF. The fans of the coolers shall cut in and out depending upon the CF temperature. The circulation pumps shall also pump CF into the regeneration circuit, which shall be equipped with filter (12μ) for continuous filtration of the CF. (Applicable if CF is used). Cooling by air shall be foreseen if the ambient temperature is up to 49°C. For ambient temperature more than 49°C, cooling with water shall be foreseen. Water quantity & quality requirements shall be furnished by the supplier along with the offer for arranging the same by the purchaser. Provision of heater for heating the control fluid shall be kept for projects where ambient temperature goes up to 5°C and below.</p> <p>The HPSU supplier shall mount a console containing local pressure gauges, pressure switches & nipples for commissioning measurements on the CF tank. Moreover, coarse filters with contamination indicator & pressure relief valves for pump protection are to be provided by the supplier. The complete HPSU shall be housed inside the cabinet and for emergency manual tripping, a switch shall be provided on the terminal box. HPSU Circuit diagrams drawn on either metallic or plastic sheet in color should be riveted inside the door panel. Supplier is to make an arrangement for mounting electric lamps inside the housing.</p> <p>The HPSU supplier shall provide 03 no. pressure line and 03 no. return line connections in HPSU as per the following details:</p> <ol style="list-style-type: none"> 01 no. each of pressure and return line connections for LPBP stop & control valve no.-1. 01 no. each of pressure and return line connections for LPBP stop & control valve no.-2. 01 no. each of pressure and return line connections for water injection valve(s). <p>In case the water injection valve(s) are with pneumatic actuators only 2 no. of pressure and 2 no. of return line connections shall be applicable as mentioned at sl. no. a) & b) above.</p>		
COPYRIGHT AND CONFIDENTIAL The information on this document is the property of Bharat Heavy Electricals Limited. It must not be used, directly or indirectly, in any way detrimental to the interest of the company	<p>7.1 Electric Wiring:</p> <p>Electrical wiring of all the hydraulic assemblies is part of the supplier's scope of supply. It includes measuring & signal devices. All electric components must be wired up to junction box (JB) of the unit. The JB will have IP55 degree of protection. A separate JB meant for pump motors connection shall also be provided. No internal wiring shall be done by BHEL inside the HPSU housing cabinet. JB wiring diagram along with data of all the electrical equipment as mounted on HPSU & as well as on control block of Actuators, Position measuring instruments and cable termination details must be supplied along with the main equipment. Internal wiring to JB must be housed in protective channels of galvanized sheet metal with removable covers. Steel-clad hose/conduit must protect the connecting cable to individual components. The length of free cables (i.e. at plugs or connections) should not be longer than 500mm.</p> <p>Protective devices for wiring should also be supplied for equipment, which is not wired (i.e. motors, solenoid valves), ending at the appropriate location of the base frame.</p>			
स्वत्वाधिकार एवं गोपनीय इस प्रलेख में दी गई सूचना भारत हेतु इलेक्ट्रिकल्स की सम्पत्ति है इसका प्रत्यक्ष एवं अप्रत्यक्ष रूप से किसी भी तरह का उपयोग, जोकि कंपनी के हित में हानिकारक हो न किया जाए।				
हस्ताक्षर एवं दिनांक SIGN & DATE 28/4/11				
सामग्री सूची संख्या INVENTORY NO. P-6301	REV. NO. 02	निर्माणकर्ता WORKED BY SHUBHAM MITTAL		16.4.11
		जांचकर्ता CHECKED BY R.C. AGARWAL		16.4.11

दिनांक एवं तिथि SIGN & DATE		उत्पाद मानक PRODUCT STANDARD	ST 47050 पृष्ठ 28 का 13 Page 13 of 28		
SUPERSIDES INVENTORY NO.	7.1.1 Instruments in HPSU: <ul style="list-style-type: none"> (a) Pressure transmitter is to be provided at the discharge of each CF pump and also in the CF header. All pressure transmitter to be 'SMART' type with HART protocol. (b) All filters to be equipped with differential pressure switches for alarm along with local indication for clogging. (c) Suitable pressure switches and gauges to be provided in HPSU. (d) Two (2) nos. Resistance temperature detectors along with temperature transmitters to be provided for measuring the temperature in the tank. (e) Suitable level gauges & three (3) no. level transmitters to be provided on the CF tank for level measuring. (f) Contact rating of all the switches to be furnished. (g) Number & type of instruments shall be subject to BHEL approval. Complete instrument list showing range, model no. and set point of various instruments shall be furnished for BHEL approval. 				
COPYRIGHT AND CONFIDENTIAL. The information on this documents is the property of Bharat Heavy Electrical Limited. It must not be used directly or indirectly, in any way, detrimental to the interest of the company.	7.1.2 Interface with BHEL's System: Signals from the instruments shall be processed in BHEL's system & commands from BHEL's control system shall go for controlling the motors, fans etc in the HPSU and also the Pilot valves, Servo-valves/proportional valve and TSVs in the valve actuators. Supplier is to furnish the recommended operation logics for the entire system enabling BHEL to develop suitable control schemes. <ul style="list-style-type: none"> (a) For operation of Control Valves, BHEL shall supply ± 7.5 mA / ± 30 mA signal to servo-valves/ proportional valves from its DCS. (b) In case vendor system is not able to accept this signal, 4-20 mA demand signal can be furnished by BHEL. In such a case suitable positioner shall be supplied by the vendor for interfacing with servo-valve / proportional valve. In this case, final operation of all the components of actuators (stop valves, control valves and water injection valves), i.e. TSVs, Pilot valves and interlocking valves shall also be from vendor's system. Suitable signals shall be provided from BHEL's DCS for control of these elements. Necessary software for calibration / parameterization of the positioner shall also be supplied. 				
स्वत्वाधिकार एवं गोपनीय इस दस्तावेज में दी गई सूचना भारत भारी इलेक्ट्रिकल्स की सम्पत्ति है इसका प्रयोग एवं अप्रत्याशित रूप से किसी भी तरह प्रयोग, जो कि कंपनी को हित में हानिकारक हो न किया जाय।	7.1.3 Power Supply: Power supply requirements for all 3 phase motors shall be 415V \pm 10% AC. In case of different requirement the same shall be specified in the input data sheet.				
दिनांक SIGN & DATE 28/11/11	7.2 Coating, Cleaning and Preservation: Supplier shall furnish the colour scheme for BHEL review and acceptance. Before preservation, the interior surface of the HPSU must be cleaned thoroughly. Before delivery of HPSU, the unit should be coated inside with hydraulic fluid containing a suitable inhibitor. Additives used must not degrade the quality of hydraulic medium. All external connections must be sealed with metal plugs. All items as listed in the supplier's part list have TAG nos. & must have nameplates, which shall be attached in such a way so that they can be seen & read easily. Nameplates must be designed 10X50 mm with 7-mm inscription height & mounted by notch spikes.				
शपथी सूची संख्या INVENTORY NO. P-6301	REV. NO. 02		निर्माणकर्ता WORKED BY SHUBHAM MITTAL		16.4.11
			जांचकर्ता CHECKED BY R.C. AGAWRAL		16.4.11

सामग्री सूची संख्या
INVENTORY NO.

8.0 TOOLS & TACKLES:

The bidder shall submit with the equipment one complete set of all special tools & tackles & other instrument required for site erection & commissioning, assembly, disassembly & proper maintenance of the LP Bypass system. The bidder along with the offer shall submit a list of such tools and tackles. In case, new requirement of any special tool arises during installation of LP bypass system equipments the same shall be supplied by the supplier free of cost.

COPYRIGHT AND CONFIDENTIAL
 The information on this documents is the property of Bhatia Heavy Electrical Limited. It must not be used directly or indirectly in any way, detrimental to the interest of the company.

9.0 MATERIAL & SURFACE PROTECTION:

9.1 Material Selection

The materials for all components must be for maximum corrosion resistance under the prevailing ambient conditions. The material utilized for manufacture of various components shall be those, which are already established for use in such applications. Material of all the major items of LP Bypass valves, actuators & HPSU shall be informed during offer stage for purchaser's acceptance. However, during detailed engineering stage if it is established that the materials as informed by the bidder is inferior to present practices, the supplier without any commercial implications shall change it.

9.2 Material Testing:

Product forms for load-bearing parts shall be supplied with **Inspection Certificate 3.1 B as per EN10204**. The product forms for other parts shall be specified in the parts list including bill of material, indicating therein the material number and the standard, including trade names if necessary.

स्वाम्यधिकार एवं गोपनीय
 इस प्रलेख में दी गई सूचना भारत हेतु इलेक्ट्रिकल्स की संपत्ति है इसका प्रत्यक्ष एवं अप्रत्यक्ष रूप से किसी भी तरह प्रयोग, जो कि कम्पनी के हित में संश्लेषणक हो न किया जाए।

9.3 Welding Materials & Consumables:

The properties of welding materials and consumables to be employed (mechanical, chemical, thermal, long term performance etc.) shall be matched to the base metal. The supplier shall ensure that the welding materials and consumables have National/International approval for the intended application. For site erection purpose, the supplier shall submit to the purchaser the Field Welding Schedule (FWS) for field welding activities. The FWS shall be submitted to the Purchaser/Owner along with all supporting procedures, like welding procedures, heat treatment procedures, NDT procedures etc., at least 30 days before schedule start of erection work at site.

9.4 Welder Qualifications:

For the work to be performed only those welders shall be used who are qualified as per DIN EN287-1 or per any comparable Indian/International standard for metals to be welded and the welding procedure to be employed.

हस्ताक्षर एवं दिनांक
SIGN & DATE
 28/11/11

सामग्री सूची संख्या
INVENTORY NO.
 P-6301

REV. NO. 02		निर्माणकर्ता WORKED BY	SHUBHAM MITTAL	16.4.11
		जांचकर्ता CHECKED BY	R.C. AGARWAL	16.4.11



उत्पाद मानक

ST 47050

पृष्ठ 28 का 15

PRODUCT STANDARD

Page 15 of 28

दिनांक एवं हस्ताक्षर
SIGN & DATE

सामग्री सूची संख्या
को अधिलेखित करना
SUPERSEDES
INVENTORY NO.

COPYRIGHT AND CONFIDENTIAL
The information on this documents is the property of Bharat Heavy Electrical Limited. It must not be used directly or indirectly in any way detrimental to the interest of the company

स्वत्वाधिकार एवं गोपनीय
इस प्रलेख में तीनों पक्षों भारत भारती इंजीनियरिंग्स की संपत्ति है इकाई प्रत्यक्ष एवं अप्रत्यक्ष रूप से किसी भी तरह प्रयोग, को कि कंपनी के हित में हानिकारक हो न किया जाए।

हस्ताक्षर एवं दिनांक
SIGN & DATE

सामग्री सूची संख्या
INVENTORY NO.

10.0 FUNCTIONAL & TESTING REQUIREMENTS: (Refer Format-1, APPENDIX-6)

Supplier shall furnish & specify the various functional & test requirements of LP Bypass valves, Actuators & HPSU in the prescribed format as enclosed and submit the same for BHEL approval.

The supplier shall also furnish copies of the reference documents/their standards/acceptance norms/tests & inspection procedure etc. as specified in the format-1. Without approval of functional & testing requirements, the supplier will not start manufacturing. This document shall form a part of the contract.

BHEL/Owner shall identify customer hold points (CHP), i.e. test/checks which shall be carried out in presence of the BHEL/Owner's Engineer or his authorized representative and beyond which the work will not proceed without consent of Purchaser/Owner/Authorized representative in writing.

Following functional tests are to be carried out at supplier works:





1. HPSU testing as per suppliers approved test procedure
2. LP Stop & Control Valve Actuators testing without bypass valve as per supplier's approved procedure
3. Cv test (type test) of LP Bypass Valve without actuators:
 - (i) Cv test will be carried out for LP Bypass valve as per ISA 75.02 and test report shall be submitted for BHEL approval. The Cv test can be carried out physically on the valve or through computer simulation.
 - (ii) The Cv test shall be carried out in presence of the BHEL representative, for which minimum 30 days notice shall be given by the supplier. The supplier shall obtain the BHEL approval for the Cv test procedure before conducting the Cv test. The Cv test procedure shall clearly specify the test set-up, instruments to be used, procedure, acceptance norms, recording of different parameters, interval of recording, precautions to be taken etc. for the Cv test to be carried out.
 - (iii) In case test report is already available on the same model/type/size/rating of the valve as proposed to be supplied under this contract and the Cv test have been either conducted at any independent laboratory or have been witnessed by a client, the same can be considered if Cv test have been carried out not more than 5 years from the date of bid opening.
 - (iv) In case the offered valve is already in successful operation using the same valve body, seat and trim combination as of the offered valve, the vendor may furnish the name of project, data sheet, cross sectional drawing of that valve for review in lieu of the Cv test report.



4. NDT of castings/forgings:
 - (a) The ultrasonic test shall be carried out as follows:
 - I. Forgings conforming to quality level-4 as per EN 10228-3.
 - II. Castings conforming to the following requirements as per EN 12680-2:
 - (i) All the weld seams, high stress areas and sealing surfaces shall conform to quality level-I.
 - (ii) Rest of the casting shall conform to quality level-II.

REV. NO. 02

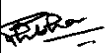
निर्माणकर्ता WORKED BY	SHUBHAM MITTAL		16.4.11
जांचकर्ता CHECKED BY	R.C. AGARWAL		16.4.11



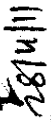



P-6301

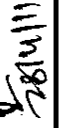
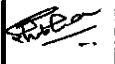
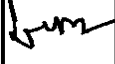

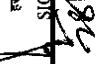
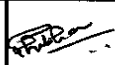
दिनांक एवं हस्ताक्षर SIGN & DATE		उत्पाद मानक PRODUCT STANDARD	ST 47050 पृष्ठ 28 का 16 Page 16 of 28	
सामग्री सूची संख्या को अतिरिक्त संख्या SUPERSEDES INVENTORY NO.	<p>(b) WPS & PQR shall be got approved by BHEL, before start of welding on weld seams.</p> <p>(c) Stress relieving shall be performed after welding. The vendor shall report the hardness survey of the heat affected zone (HAZ), weld and parent materials.</p> <p>(d) All the weld seams shall be radiographically tested conforming to quality level-I as per ASTM E446.</p> <p>5. Hydrostatic body test of LP bypass valve in accordance with ANSI B-16.34 prior to seat leakage test.</p> <p>6. Valve closure test and seat leakage test in accordance with ANSI B-16.34 and as per the leakage class MSS SP61.</p> <p>7. LP Bypass valves testing along with actuators in assembled condition.</p> <p>8. Functional test: The fully assembled valves including actuators control devices and accessories shall be functionally tested to demonstrate times from open to close position.</p> <p>Any additional requirement, if any, shall be separately specified in the purchase order.</p> <p>In general, highest quality of workmanship shall be ensured while manufacturing and assembly of LP Bypass valves, their actuators and HPSU.</p> <p>10.1 TEST CERTIFICATES:</p> <p>Supplier has to furnish the Test Certificates, Material Certificates; certificates for weld examination, leakage test, hot tensile tests etc before delivery.</p> <p>11.0 SPARES:</p> <p>11.1 Commissioning & Startup Spares:</p> <p>Spare & wear parts are included in the scope of supply up to completion of trial operation. The supplier shall prepare lists of all probable spares and wear parts, which indicate the recommended quantities and clear parts identification. The parts shall be manufactured in accordance with the requirements of this specification.</p> <p>(1) It will be the responsibility of the supplier to provide all commissioning and startup spares required for initial operation till the satisfactory completion of the Trial Operation. The supplier to ensure that no hold ups shall occur at site during erection & commissioning due to non-availability of commissioning spares. The supplier shall furnish a list of all such spares within 60 days from the date of Letter of award & such list shall be reviewed by the purchaser/Owner & mutually agreed to. List of commissioning spares shall include 1 set each of all those items which may get damage during transportation/storage such as receptical connectors & other items e.g. gaskets, packing rings, filters etc.</p> <p>(2) These spares will be received & stored by the purchaser at least 3 months prior to the date of commencement of trial operation & utilized as and when required.</p>			
COPYRIGHT AND CONFIDENTIAL The information on this documents is the property of Bharat Heavy Electrical Limited. It must not be used directly or indirectly in any way detrimental to the interest of the company				
	स्वत्वाधिकार एवं गोपनीय इस प्रलेख में दी गई सूचना भारत की स्वतंत्रता को सुरक्षित है इसका प्रकाश एवं अपरिष्कार रूप से किसी भी तरह प्रयोग, जो कि कंपनी के हित में हानिकारक हो न किया जाए।			
हस्ताक्षर एवं दिनांक SIGN & DATE 	28/11/11			
सामग्री सूची संख्या INVENTORY NO. P-6301	REV. NO. 02		निर्माणकर्ता WORKED BY SHUBHAM MITTAL 	16.4.11
			जांचकर्ता CHECKED BY R.C. AGARWAL 	16.4.11

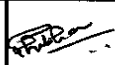
दिनांक एवं हस्ताक्षर SIGN & DATE		उत्पाद मानक PRODUCT STANDARD	ST 47050 पृष्ठ 28 का 17 Page 17 of 28	
सामग्री सूची संख्या को SUPERSEDES INVENTORY	<p>11.2 Mandatory Spares:</p> <p>The bidder shall submit their commercial offer separately for the mandatory spares as per the list furnished by the Purchaser/Owner. List of mandatory spares furnished by the bidder shall be duly correlated with their bill of material.</p> <p>11.3 Recommended Spares:</p> <p>In addition to the mandatory spares, the bidder is required to submit as part of the contract, a complete list of recommended spare parts, for the equipment supplied based on his experience, which are essential for a plant operation of ten (10) years. In the offer, the bidder is required to furnish item wise price and total lump sum price. The purchaser is free to order these recommended spare parts at any time.</p> <p>The bidder shall also indicate the service expectancy period for the spare parts under normal operating condition before the replacement is necessary. All categories of spares to be supplied under this contract shall be strictly interchangeable with the parts for which they are intended for replacement. The spares shall be treated and packed for long storage under the climate conditions prevailing at the site e.g. small items shall be packed in sealed transparent plastic bags with desiccators packs as necessary.</p> <p>Each spare shall be clearly marked or labeled on the outside of the packing with its description and assembly parts number.</p> <p>11.4 General Technical requirements for Spares:</p> <p>(i) All the mandatory spares covered under the contract shall be manufactured along with the main equipment as a continuous operation and the delivery of the spares will be affected along with the main equipment. In case of recommended spares the above will be applicable provided the order for the recommended spares have been placed with the supplier prior to commencement of manufacture of the main equipment.</p> <p>(ii) The quality plan and the inspection requirement finalized for the main equipment will also be applicable to the corresponding spares.</p> <p>(iii) The bidder will submit along with the offer the manufacturing drawings, catalogues, assembly drawings and any other document to identify the recommended spares.</p> <p>(iv) The supplier will provide the purchaser with all the addresses and particulars of his sub-vendors while placing the order on them for items/components/equipment covered under the contract. He will further ensure that the purchaser/Owner if so desires will have the right to place order for spares directly on his sub-suppliers on mutually agreed terms based on their offers.</p>			
COPYRIGHT AND CONFIDENTIAL The information on this documents is the property of Bharat Heavy Electrical Limited. It must not be used directly or indirectly in any way detrimental to the interest of this company		स्वत्साधिकार एवं गोपनीय इस दस्तावेज में कोई भी सूचना भारत हेवी इलेक्ट्रिकल्स की संपत्ति है इसका प्रत्यक्ष एवं अप्रत्यक्ष रूप से किसी भी तरह प्रयोग, जो कि कंपनी के हित में हानिकारक हो न		
हस्ताक्षर एवं दिनांक SIGN & DATE 				
सामग्री सूची संख्या INVENTORY NO P-6301	REV. NO. 02		निर्माणकर्ता WORKED BY SHUBHAM MITTAL 	16.4.11
			जांचकर्ता CHECKED BY R.C. AGARWAL 	16.4.11

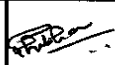
दिनांक एवं हस्ताक्षर SIGN & DATE		उत्पाद मानक PRODUCT STANDARD		ST 47050	
				पृष्ठ 28 का 18 Page 18 of 28	
सामग्री सूची सूचना को	SUPERSEDES INVENTORY	12.0 PROCESSING & DOCUMENTATION: <p>It is the duty of the system supplier to clarify interfaces and good cooperation with their sub-suppliers of products that interface with his scope of supply, both in the planning phase as well as on site. The supplier will be notified in writing in the event of any changes (additions or deletions) in the scope of supply and services, with written confirmation to follow on the part of the purchaser. The written confirmation does not constitute acceptance of the indicated additional or reduced costs.</p> <p>All major functional and mechanical design decisions shall be made together with the purchaser as per mutually agreed meeting schedules.</p> <p>12.1 Processing Documents:</p> <p>All verification analysis, which demonstrates compliance with design warranted & specified data and which include information on interface to adjacent systems shall subsequently be designated processing, documents and shall be submitted to the purchaser for review.</p> <p>Verification analysis required by legislative bodies, regulatory authorities or similar entities of this nature should also be treated as processing documents. The documents to be reviewed by the purchaser or his authorized representative are listed in Section 14.2 & 14.3 below. The purchaser or designated authorized inspectors can also demand to see the documents or verification analysis to be submitted for preliminary review. All documents shall be reviewed by the supplier before being submitted unsolicited to the purchaser /authorized representative.</p> <p>Fabrication/Manufacturing may begin only after the submission of approved documents by the purchaser.</p> <p>The supplier shall check the drawings provided for parts from outside vendors for any interface with his own parts at his own end. The supplier shall also finalize all type of interface activities with their own sub-vendors. The supplier shall be held responsible for any mistake done during detailed engineering or manufacturing by their sub-vendor. The extra cost incurred due to this interface shall be borne by the supplier.</p> <p>The lists and schematic diagrams for instrumentation and open- and closed loop controls if prepared by the supplier shall be thoroughly checked by the supplier for completeness and correctness. All necessary drawings, detailed drawings and spare parts drawings shall be prepared using computer- based drawing programs. These must be deposited finally to the purchaser on disk and must be "AutoCAD" compatible. The required scope of documentation is established in the scope of supply. All documents shall be prepared in the project-specific language stipulated.</p> <p>In all instances, project-specific requirements must be duly noted and complied with when preparing & identifying the documents.</p> <p>The purchaser shall be made aware of all changes in the supplier's drawings by pointing out the revision remarks and indices on them is not sufficient. Physical parameters and drawing dimensions shall be given in metric units in accordance with Indian Standards.</p>			
COPYRIGHT AND CONFIDENTIAL The information on this documents is the property of Bharat Heavy Electrical Limited. It must not be used directly or indirectly in any way detrimental to the interest of the company					
स्वाधिकार एवं गोपनीय इस दस्तावेज में दी गई सूचना भारत इलेक्ट्रिकल्स की सम्पत्ति है और इसका प्रयोग एवं आश्रय के बिना से किया जा सकता है। जो कि भारत के हित में हानिकारक हो न किया जाए।					
हस्ताक्षर एवं दिनांक SIGN & DATE 5/8/11					
सामग्री सूची संख्या INVENTORY NO. P-6301	REV. NO. 02		निर्मापकता WORKED BY SHUBHAM MITTAL		16.4.11
			जांचकर्ता CHECKED BY R.C. AGARWAL		16.4.11

नमूने का संख्या SIGN & DATE		उत्पाद मानक PRODUCT STANDARD	ST 47050	
शरणी सूची संख्या को अधिकतम करता	SUPERSEDES INVENTORY NO.	<p>12.2 Review Documents:</p> <p>Following drawings and data are to be furnished along with the technical offers in triplicate.</p> <p>12.2.1 Documents related to HPSU:</p> <ol style="list-style-type: none"> 1. Schematic circuit diagram showing connection of HPSU with respective bypass actuators & Sizing calculation of HPSU & its main components. 2. General arrangement drawing of HPSU indicating therein the total assembly weight, overall major layout dimensions, foundation detail, space requirement for maintenance, Flanges end connection detail and their material. 3. Schematic diagram duly indicated with all item nos., Tag Nos. and legends. In this diagram, tank capacity, pump capacity of each CF Pumps, Circulation Pumps, rated power consumption of each pump motor, filtration rating of each filter and capacity of each Hydraulic Accumulators has to be specified. 4. Part list duly indicated with item no/Position No., quantity, catalogued / Drg. reference no. & source of procurement etc. BHEL will indicate their TAG nos. against each item for identification purpose and submit the same to the supplier for necessary updation. 5.* HPSU Test procedure duly indicating therein the test detail & their acceptance norms. 6. Data sheets & *functional description of all individual items. Electrical wiring diagram. 7.* Operation, Maintenance & Erection manual. 8.* Field Weld Schedule and erection instruction for site engineers. 9.* List of Bought out items, the source of procurement has to be specified for each item. 10. List of recommended and commissioning spares. 11. Detailed 'Quality Plan' for HPSU. (See Clause no. 10.0) <p>12.2.2 Documents related to LP Bypass Valves & Actuators:</p> <ol style="list-style-type: none"> 1. Overall General arrangement cross-sectional assembly drawing with all major dimensions required from layout point of view. Steam Inlet & Outlet weld edge sizes, bracket for Valve suspension arrangement, and location of center of gravity and also total assembly weight has to be specified in the drawings. Bill of material (BOM) of the valve with actuator assembly has to be tabulated. Assembly & disassembly maintenance space dimensions should be indicated in the drawings. 2. Separate Stop & Control Valve actuator drawings indicating therein the flange end connection detail, total actuator weight, overall dimension & dismantling space requirement. All items should be marked and listed in the BOM on the drawing itself. On the actuator drawings, schemes for Stop & Control valve actuator should also to be shown schematically. 3.* Catalogs and technical literature of Solenoid valves, Servo-valves, proportional valves, Position transducer, Positioners, Limit Switches, Relief Valves etc. 4. Sizing Calculation for Bypass valves & actuators. 5. Valve Data Sheets for LP Bypass Valve 6. List of special tools (if any) 		
COPYRIGHT AND CONFIDENTIAL The information on this documents is the property of Bharat Heavy Electrical Limited. It must not be used, directly or indirectly in any way detrimental to the interest of the company				
स्वत्वाधिकार एवं गोपनीय इस दस्तावेज में दी गई सूचना भारत हेवी इलेक्ट्रिकल्स की संपत्ति है इसका प्रत्यक्ष एवं अप्रत्यक्ष रूप से किसी भी तरह प्रयोग, जो कि कंपनी के हित में अधिकारक हो न किया जाए।				
हस्ताक्षर एवं दिनांक SIGN & DATE 				
शरणी सूची संख्या INVENTORY NO. P-6301	REV. NO. 02		निर्माणकर्ता WORKED BY SHUBHAM MITTAL 	16.4.11
			जांचकर्ता CHECKED BY R.C. AGARWAL 	16.4.11

दिनांक एवं हस्ताक्षर SIGN & DATE		उत्पाद मानक PRODUCT STANDARD	ST 47050 पृष्ठ 28 का 20 Page 20 of 28								
सामग्री सूची संख्या INVENTORY NO	7. Valve characteristics - Lift vs Area ; Lift vs Flow - Pressure vs flow (upstream side/ down stream side) 8.* Part list of Valves, Actuators. BHEL will indicate their Tag nos. against each item and the same shall be submitted to the supplier for necessary updation. This is required for identification purpose. 9. List of Recommended & Commissioning spares. The supplier along with the main equipment shall supply commissioning spares for Valves, Actuators & HPSU. 10.* Valve & actuator test procedure. Test log sheets for valves and actuators. 11. Detailed QP for combined LP Bypass Stop & Control valves and their actuators. 12.* List of Instruments duly indicated with BHEL Tag Nos., service, set points, range & make etc. to be furnished. 12.2.3 Documents related to Water Injection Valves & Actuators: 1. Data sheets of valve & actuator indicating therein all parameters & material details. 2. General arrangement drawing of valve with actuator indicating therein major dimensions, dismantling dimensions & assembly weight. Bill of material must be tabulated on the assembly drawing. 3. Pneumatic/ Hydraulic actuator scheme (as applicable) indicating therein part numbers. 4. Part List of valve actuator. 5. Drawing for valve & actuator coupling arrangement. 6. Sizing calculation for valve & actuator. 7. Curve for water mass flow vs. % lift (indicating % lift at max. design water mass flow & min. controlled water mass flow). 8. Data sheets for all the items mounted on the control manifold. 9. Wiring diagram for electrical items. 12.2.4 Other Documents related to C & I: 1. Flow Nozzle data sheet as per ISO 5167. 2. Flow Nozzle drawing. 3. Flow Nozzle characteristic curve between differential pressure and flow (indicating calculation formula also). 4. List of Instruments (HPSU and Actuators) duly indicated with KKS Tag Nos., type, service, set points, range & make etc. 5.* Consumer list, Drive list, Signal I/O List. 6.* Recommended system logics/write-up. 7.* Electrical Terminal Wiring Details (HPSU Junction Boxes/Positioners and other components) 8.* Cabling Layout Diagram. 9.* Electro-pneumatic positioner catalogue (If applicable). 10.* Instruments Catalogues and data sheets of all electrical components. 11.* Separate feeder load list to be furnished, giving details of Power Supply, KW rating, Current drawn etc. for various motors, fans and other electrical drives. Note: '*'- These documents are required separately after placement of order.										
COPYRIGHT AND CONFIDENTIAL The information on this document is the property of Bharat Heavy Electrical Limited. It must not be used directly or indirectly in any way, detrimental to the interest of the company.											
स्वत्वाधिकार एवं गोपनीय इस प्रलेख में दी गई सूचना भारत हेवी इलेक्ट्रिकल्स की संपत्ति है इस्का प्रयोग एवं आरक्षण के बिना किसी भी तरह प्रयोग, जो कि कंपनी के हित में सांझाकरण हो न किया जाए !											
हस्ताक्षर एवं दिनांक SIGN & DATE 											
सामग्री सूची संख्या INVENTORY P-6301	REV. NO. 02		<table border="1"> <tr> <td>निर्माणकर्ता WORKED BY</td> <td>SHUBHAM MITTAL</td> <td></td> <td>16.4.11</td> </tr> <tr> <td>जांचकर्ता CHECKED BY</td> <td>R.C. AGARWAL</td> <td></td> <td>16.4.11</td> </tr> </table>	निर्माणकर्ता WORKED BY	SHUBHAM MITTAL		16.4.11	जांचकर्ता CHECKED BY	R.C. AGARWAL		16.4.11
निर्माणकर्ता WORKED BY	SHUBHAM MITTAL		16.4.11								
जांचकर्ता CHECKED BY	R.C. AGARWAL		16.4.11								

दिनांक एवं तिथि SIGN & DATE		उत्पाद मानक PRODUCT STANDARD	ST 47050 पृष्ठ 28 का 22 Page 22 of 28	
शीर्षक सूची संख्या INVENTORY NO	SUPERSEDES INVENTORY NO	15.0 SUPERVISION DURING ERECTION-COMMISSIONING & TRAINING AT SITE: <p>The supplier shall depute their representative at project site for erection & commissioning supervision. The lump sum charges for site supervision shall be included in the main offer for which the supplier has to provide the justification in the offer.</p> <p>The supplier shall conduct minimum 2 days training program at site regarding design/construction features, operation & maintenance of the supplied equipments (including C&I) for customer engineers and BHEL engineers during erection and commissioning. Schedule of the program shall be mutually agreed between supplier and customer/ BHEL engineers.</p> <p>The vendor to clearly indicate the extent of association of their service engineer during erection and commissioning of the supplied equipments at site in their offer. Further special instructions which are required to be followed at site during erection and commissioning shall be furnished by the vendor as per the schedule mentioned in the enclosed MDL.</p>		
शीर्षक सूची संख्या INVENTORY NO	SUPERSEDES INVENTORY NO	16.0 GUARANTEE: <p>The complete unit shall be guaranteed for 24 months of trouble free performance from the date of shipment or 18 months from commissioning date whichever is earlier. In case of any failure or trouble reported from site, the supplier would depute their representative immediately to attend the problem and replace the defective component/parts if required.</p>		
स्वत्वधिकार एवं गोपनीय <small>इस प्रलेख में दी गई सूचना भारत के विद्युत विभाग की सम्पत्ति है इसका प्रयोग एवं आश्रय रूप से किसी भी तरह प्रयोग, जो कि कंपनी के हित में हानिकारक हो न किया जाए।</small>	COPYRIGHT AND CONFIDENTIAL. <small>The information on this documents is the property of Bharat Heavy Electrical Limited. It must not be used directly or indirectly in any way detrimental to the interest of the company</small>	17.0 PRICE: <p>The supplier is to furnish the price against each assembly separately for the scope of supply as indicated in the input data sheet.</p>		
दिनांक एवं तिथि SIGN & DATE	दिनांक एवं तिथि SIGN & DATE	18.0 LIST OF CROSS REFERRED DOCUMENTS: - ASTM A312; DIN51519; EN10204; DIN EN287-1, EN 10228-3, EN 12680-2, ASTM E446.		
शीर्षक सूची संख्या INVENTORY NO	REV. NO. 02	निर्माणकर्ता WORKED BY	SHUBHAM MITTAL	 16.4.11
शीर्षक सूची संख्या INVENTORY NO	P-6301	जांचकर्ता CHECKED BY	R.C. AGARWAL	 16.4.11



उत्पाद मानक PRODUCT STANDARD

APPENDIX-1

GENERAL ARRANGEMENT OF LP BYPASS VALVES (TYPICAL)

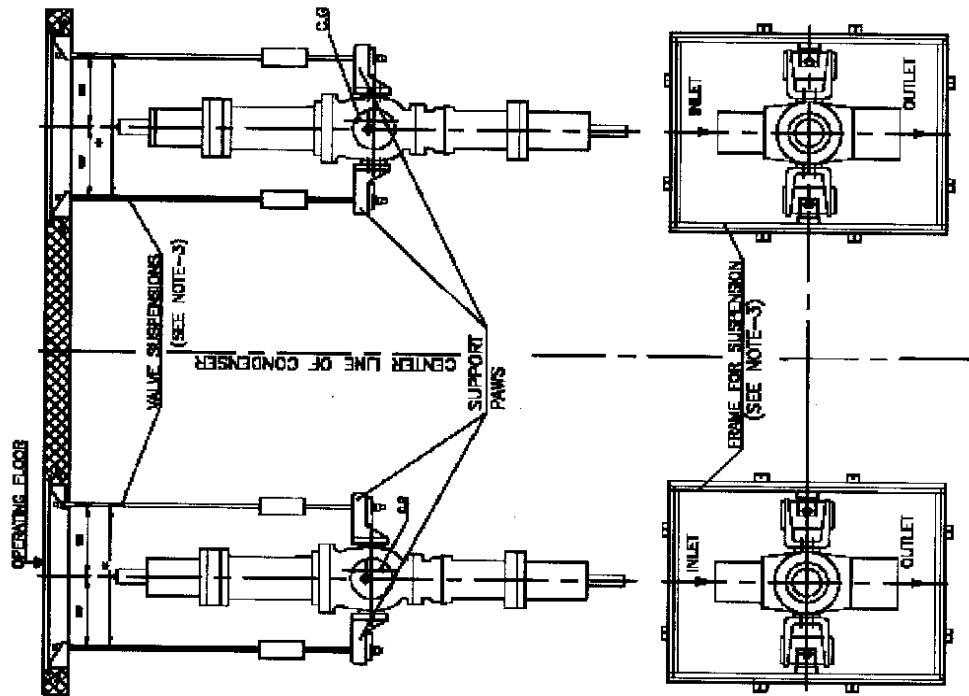

- NOTE :**
1. SUPPORT PAWS AS SHOWN SHALL BE AN INTERNAL PART OF VALVE AND THESE SHALL BE IN SCOPE OF VALVE MANUFACTURER DIMENSIONS AS MARKED * SHALL BE FURNISHED BY VALVE MANUFACTURER ALONGWITH THE TECHNICAL OFFER.
 2. FRAME FOR VALVE SUSPENSION AND BYPASS VALVE SUSPENSION SHALL BE IN THE PURCHASER SCOPE I.e. IN BHEL SCOPE.
 3. VALVE MANUFACTURER HAS TO FURNISH THE TOTAL ASSEMBLY WEIGHT AND ALL MAJOR DIMENSIONS AND ALSO THE CO-ORDINATES OF C.G.
 4. STEAM OUTLET CONNECTION OF BYPASS VALVE SHALL BE CONNECTED WITH PIPE CONNECTED FURTHER WITH CONDENSER WITH 1° SLOPE.

रणनीति संख्या INVENTORY NO. P-6301	रणनीति संख्या एवं तिथि SIGN & DATE 28/11/11	स्वतंत्रता एवं गोपनीय इस दस्तावेज़ में दी गई सूचना भारत देश की आर्थिक/सुरक्षा के सम्बन्धित है इसका प्रयोग अथवा इसमें कोई भी परिवर्तन, जो कि किसी भी रूप में किया जाए :	COPYRIGHT AND CONFIDENTIAL The information on this document is the property of Bharat Heavy Electrical Limited. It must not be used directly or indirectly in any way detrimental to the interest of the company.	रणनीति संख्या INVENTORY NO. ST 47050	पृष्ठ 28 का 23 Page 23 of 28
---	--	---	--	---	---------------------------------

रणनीति संख्या INVENTORY NO. P-6301	रणनीति संख्या एवं तिथि SIGN & DATE 28/11/11	स्वतंत्रता एवं गोपनीय इस दस्तावेज़ में दी गई सूचना भारत देश की आर्थिक/सुरक्षा के सम्बन्धित है इसका प्रयोग अथवा इसमें कोई भी परिवर्तन, जो कि किसी भी रूप में किया जाए :	COPYRIGHT AND CONFIDENTIAL The information on this document is the property of Bharat Heavy Electrical Limited. It must not be used directly or indirectly in any way detrimental to the interest of the company.	रणनीति संख्या INVENTORY NO. ST 47050	पृष्ठ 28 का 23 Page 23 of 28
---	--	---	--	---	---------------------------------

	REV. NO. 02				
				निर्माणकर्ता WORKED BY SHUBHAM MITTAL	16.4.11
				जांचकर्ता CHECKED BY R.C. AGARWAL	16.4.11

शशी सूची संख्या
INVENTORY NO

COPYRIGHT AND CONFIDENTIAL.
 The information on these documents is the property of Bharat Heavy Electricals Limited. It must not be used directly or indirectly in any way detrimental to the interest of the company.

स्वत्वाधिकार एवं गोपनीय
 इस प्रलेख में दी गई सूचना भारत भारी इलेक्ट्रिकल्स लीमिटेड की सम्पत्ति है इसका प्रयोग एवं प्रसारण इस से किली भी तब तक प्रयोग न कीजिये जब तक कि लिखित रूप से अनुमति न मिले।

दिनांक एवं संवत्
SIGN & DATE
 28/11/11

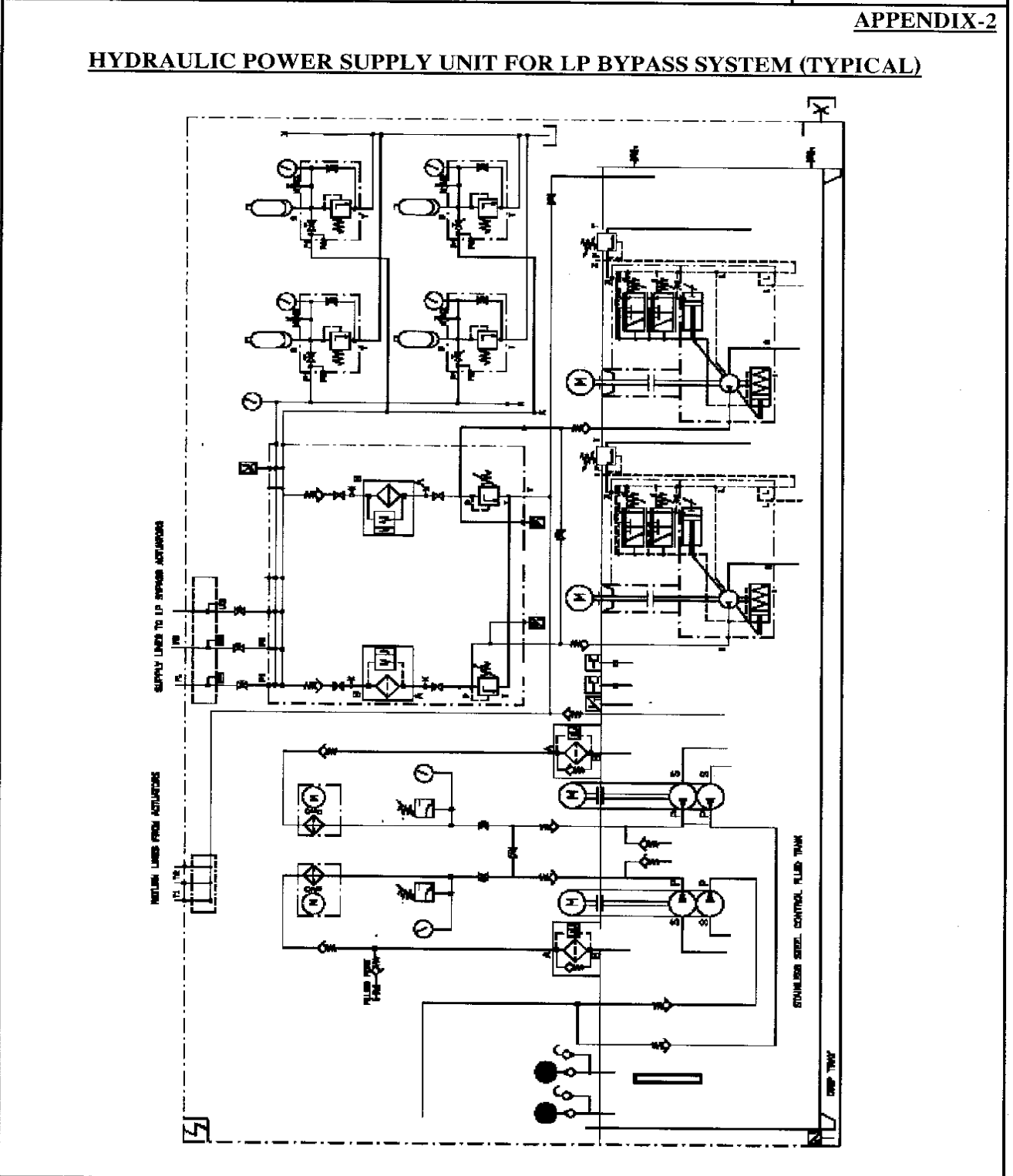

शशी सूची संख्या
INVENTORY NO
 P-6301



REV. NO. 02

निर्माणकर्ता
WORKED BY
SHUBHAM MITTAL

जांचकर्ता
CHECKED BY
R.C. AGARWAL

		16.4.11
		16.4.11



उत्पाद मानक

PRODUCT STANDARD

ST 47050

पृष्ठ 28 का 25

Page 25 of 28

APPENDIX-3

SCHEME FOR LP BYPASS STOP VALVE ACTUATOR (TYPICAL)

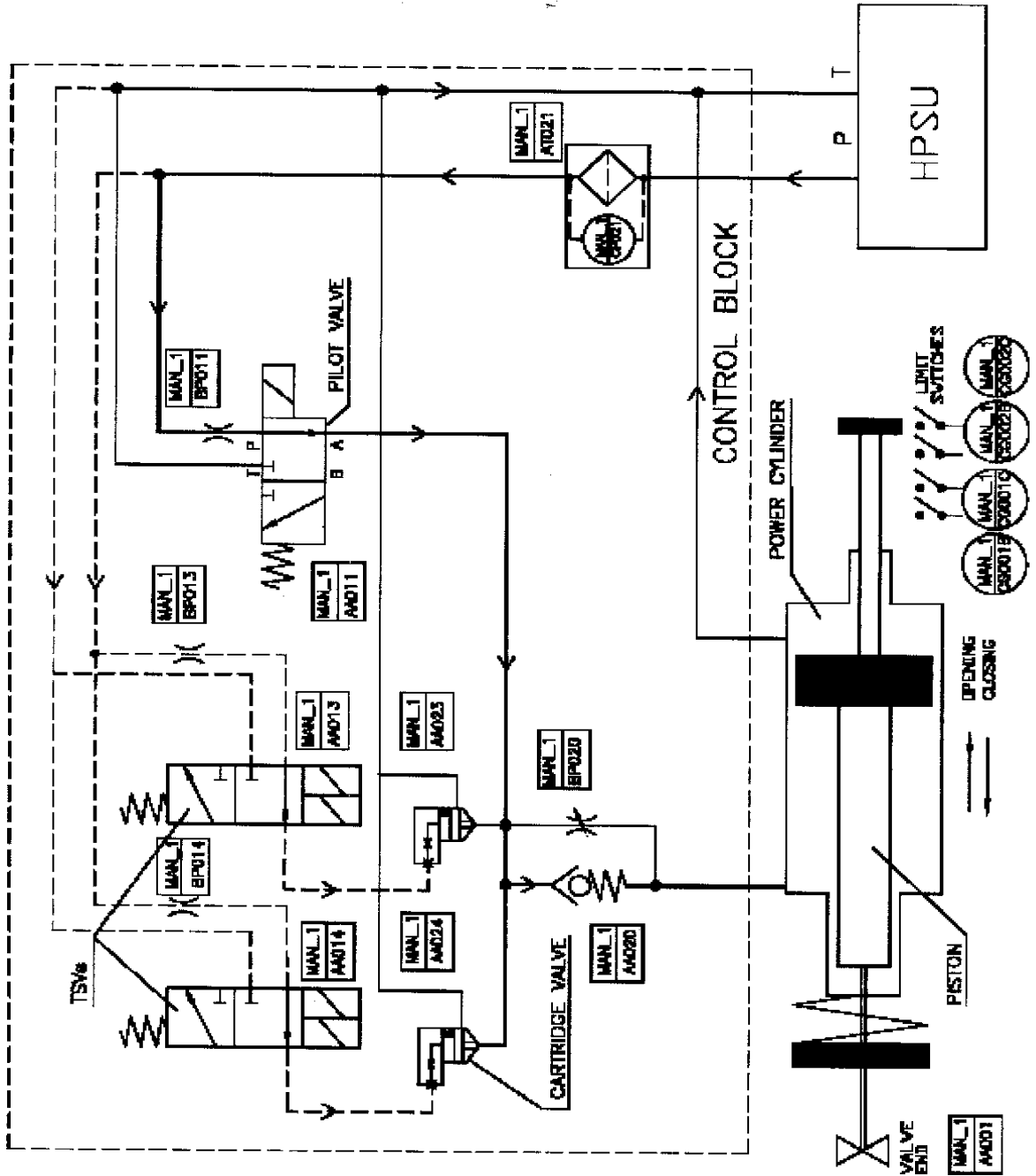

COPYRIGHT AND CONFIDENTIAL
The information on this document is the property of Bharat Heavy Electrical Limited. It must not be used directly or indirectly, in any way detrimental to the interest of the company.

स्वतन्त्रिकार एवं गोपनीय
इस दस्तावेज में की गई प्रतिलिपि के बिना अनुमति के इसका प्रयोग एवं प्रकाशन कानून से निषेधित है। इस दस्तावेज में उल्लिखित की गई जानकारी को किसी भी रूप में प्रकाशित करना गैर-गोपनीय है।

हस्ताक्षर एवं तिथि
SIGN & DATE

शुभम श्रुती संख्या
INVENTORY NO.
P-6-301

REV. NO. 02

निर्माणकर्ता WORKED BY	SHUBHAM MITTAL	16.4.11
जांचकर्ता CHECKED BY	R.C. AGARWAL	16.4.11

निर्माण एवं तारीख
SIGN & DATE



उत्पाद मानक
PRODUCT STANDARD

ST 47050
पृष्ठ 28 का 26
Page 26 of 28

समूची सूची संख्या
को अतिरिक्त संख्या
SUPERSEDES
INVENTORY NO

APPENDIX-4

COPYRIGHT AND CONFIDENTIAL
The information on this documents is the property of Bharat Heavy Electrical Limited. It must not be used directly or indirectly in any way detrimental to the interest of the company.

SCHEME FOR LP BYPASS CONTROL VALVE ACTUATOR (TYPICAL)

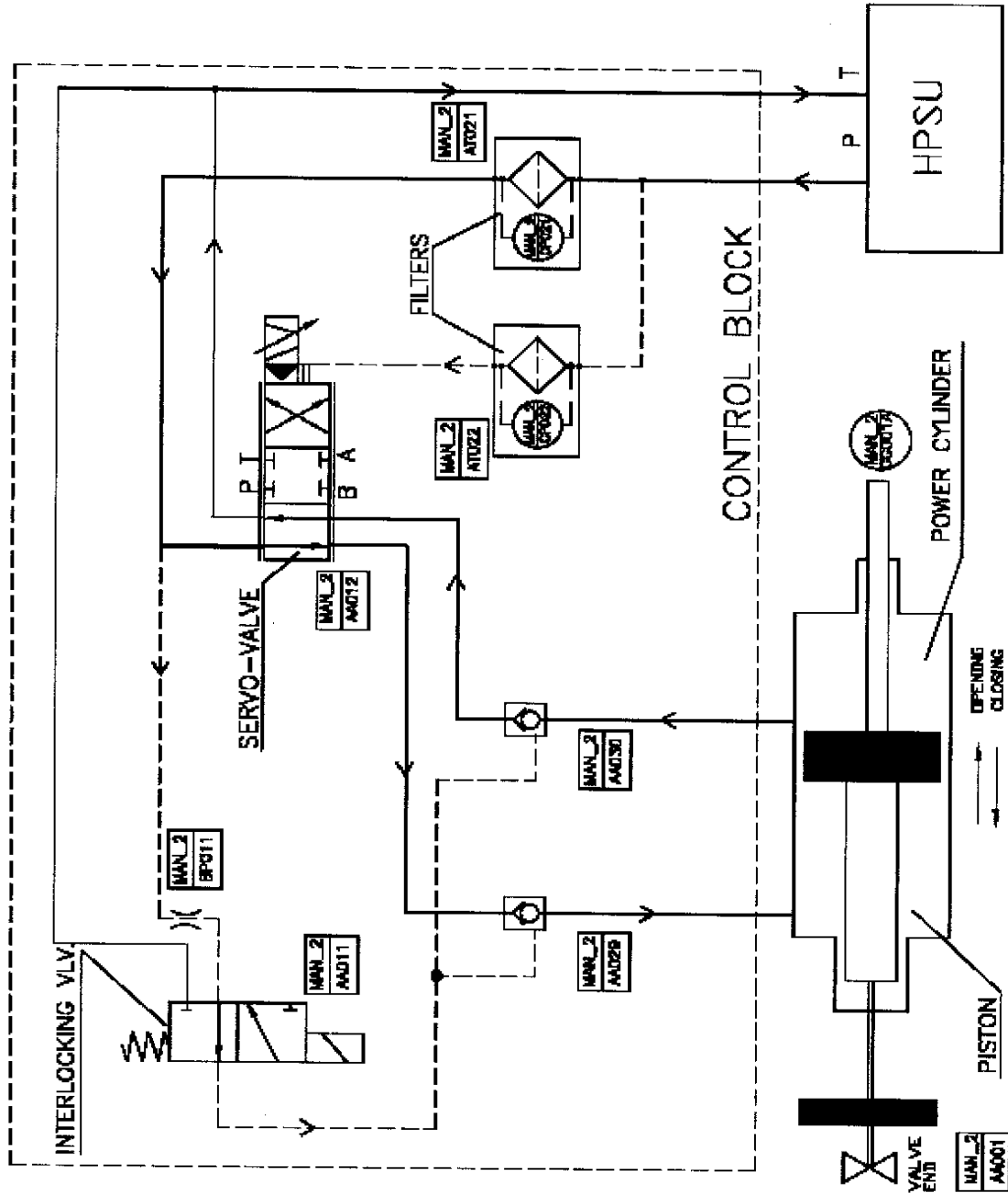

स्वाधिकार एवं गोपनीय
एन प्रोडस में दी गई सूचना भारत हेमो इलेक्ट्रिकल लि. की संपत्ति है तथाक प्रोडस एवं आरक्षण एवं को किसी भी तरह प्रयोग, जो कि कंपनी के हित में हितिकारक हो न किया जाए ।

रखतार एवं तिनांक
SIGN & DATE
28/11/11

समूची सूची संख्या
INVENTORY NO
P-6301

REV. NO. 02

निर्माणकर्ता
WORKED BY
SHUBHAM MITTAL

जांचकर्ता
CHECKED BY
R.C. AGARWAL

16.4.11

16.4.11

16.4.11

APPENDIX-5

SCHEME FOR LP BYPASS VALVE (SINGLE STEM) ACTUATOR (TYPICAL)

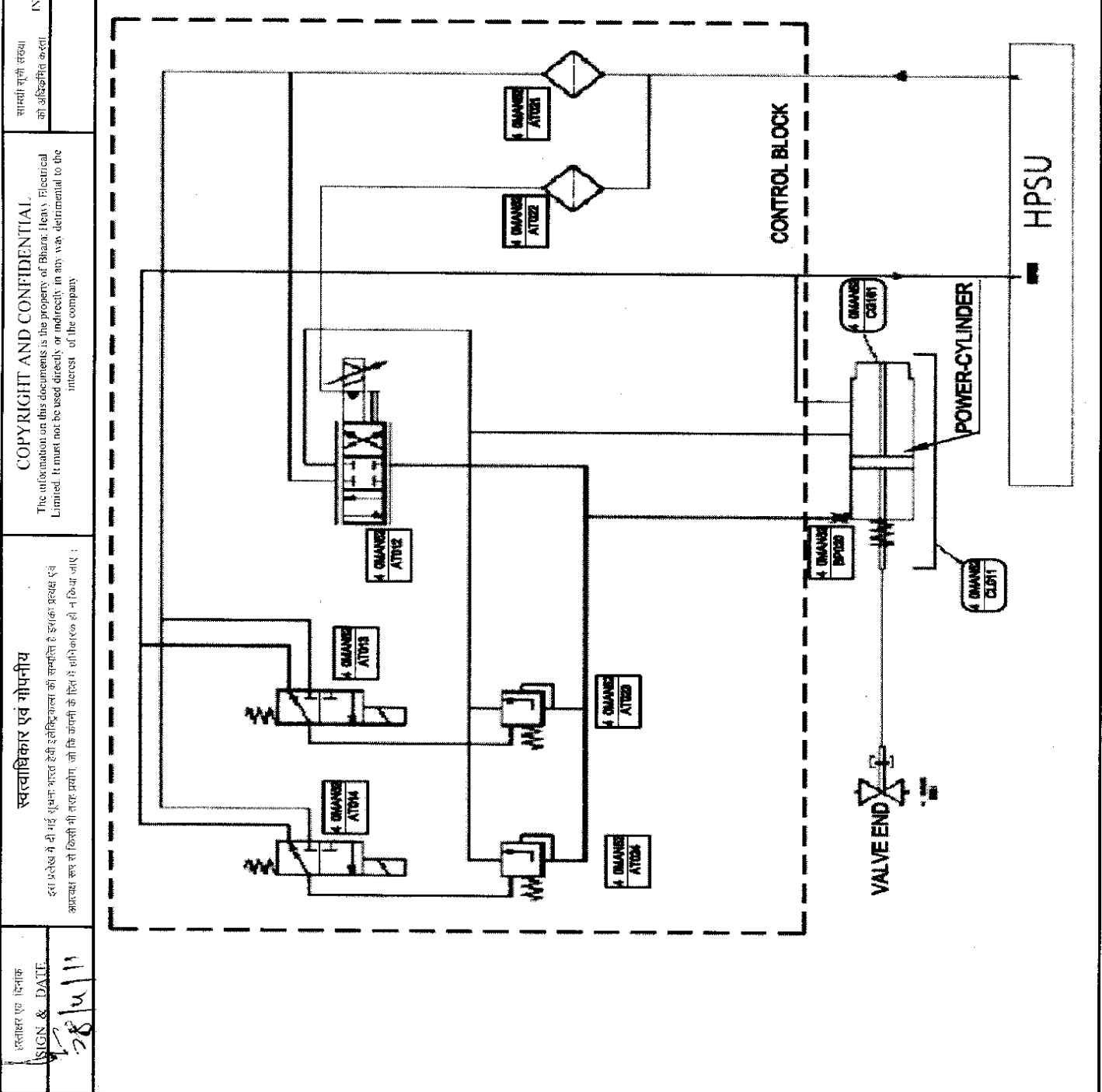

COPYRIGHT AND CONFIDENTIAL.
 The information on this document is the property of Bhabha Engineering Works Limited. It must not be used directly or indirectly in any way detrimental to the interest of the company.

स्वाधिकार एवं गोपनीय
 इस दस्तावेज में दी गई सूचना भारत देश की इलेक्ट्रिकल्स की सम्पत्ति है इसका प्रयोग एवं आविष्कार करके से किसी भी तरह प्रयोग को बिना Bhabha Engineering Works Limited की लिखित आज्ञा के नहीं किया जायेगा।

दिनांक एवं हस्ताक्षर
 SIGN & DATE
 28/4/11

सामग्री सूची संख्या P-6301	REV. NO. 02	निर्माणकर्ता WORKED BY SHUBHAM MITTAL	जांचकर्ता CHECKED BY R.C. AGARWAL	16.4.11 16.4.11
--------------------------------------	-------------	--	--	--------------------

गो सूची संख्या INVENTORY P-6301	हस्ताक्षर एवं तिथि SIGN & DATE 28/4/11	स्वत्वाधिकार एवं गोपनीयता इस प्रलेख में दी गई सूचना भारत देशी इलेक्ट्रिकल्स की सम्पत्ति है इस्का प्रयोग एवं अपवाद रूप से किसी भी तरह प्रयोग, जो बि. कंपनी के हित में हानिकारक हो न किया जाए।	कॉपीप्राइट AND CONFIDENTIAL The information on this documents is the property of Bharat Heavy Electrical Limited. It must not be used directly or indirectly in any way detrimental to the interest of the company.	समूची सूची संख्या क) सुविधाएँ बताने SUPERSEDES INVENTORY NO.	दिनांक, साक्षर SIGN & DATE
--	---	--	--	---	-------------------------------



उत्पाद मानक
PRODUCT STANDARD

APPENDIX-6, FORMAT-1

FORMAT-1		MANUFACTURER'S NAME & ADDRESS				MANUFACTURING QUALITY PLAN				PROJECT				
SL. NO.	COMPONENT OPERATION	CHARACTERISTICS	CLASS	TYPE OF CHECK	QUANTITY OF CHECK	PAGE REFER. DOC.	REV.	DATE	ACCEPTANCE OF NORMS	FORMAT OF RECORD	AGENCY REMARKS	PACKAGE		
												CONTRACT NO. :		
												CONTRACTOR :		
1	2	3	4	5	6	7			8	S				
										D	10	11		
<p>LEGEND: RECORDS IDENTIFIED WITH 'TICK' SHALL BE ESSENTIALLY INCLUDED BY CONTRACTOR IN QA DOCUMENTATION * M : MANUFACTURER/SUBCONTRACTOR C : CONTRACTOR/NOMINATED INSPECTION AGENCY INDICATE 'P'-PERFORM 'W'-WITNESS & 'V'-VERIFICATION AS APPROPRIATE, 'CHP' -SHALL BE IDENTIFIED IN COLUMN-11</p>												FOR BHEL USE	DOC NO.	
<p>MANUFACTURER/ SUB-CONTRACTOR SIGNATURE:</p>												CONTRACTOR	REVIEWED BY	NAME & SIGN OF APPRV. AUTHORITY & SEAL

निर्माणकर्ता WORKED BY SHUBHAM MITTAL	जाँचकर्ता CHECKED BY R.C. AGARWAL	16.4.11	16.4.11
--	--	---------	---------

ADDENDUM TO ST47050 Rev. 02, FOR UNCHAHAR & NEYVELI PROJECTS:-

Rev00 dtd 13.12.2014

1. For motor, paint shade shall be RAL 5012 (BLUE) for indoor and outdoor equipment.
2. Motor efficiency shall be Class-I conforming to IS 12615 or high efficiency IE2as per IEC:60034-30.
3. Clause No.6.1 (a) and wherever else applicable in BHEL specification, supplier to note that well proven Servo-Valves are to be supplied for control of LPBP Valve & Water Injection Valve in place of Proportional Valve.
4. Flow switches wherever applicable should be replaced by pressure switches.
5. There should be 3 Pressure Transmitter in the common header.
6. There should be 20 % spare terminals in each JB.
7. Cable Glands for both ends (equipment end and DCS end) shall be in Vendor's scope of supply.
8. Position feedback transmitter shall be of Balluf make.
9. In addition of Clause No.7.2, painting of equipments shall be carried as per the details given below:-
 - a) All un-insulated equipments, pipes, valves shall be painted with Epoxy resin based paints with minimum DFT of 150 micron.
 - b) The paint shall be applied in three stages i.e. primer, intermediate & finish coats in the following manner.
 - Primer coat- Epoxy based Zinc phosphate
 - Intermediate- Epoxy based TiO2 pigmented coat
 - Finish coat- Epoxy based finish coat
 - c) Equipment, pipes etc. with high temperature service shall be painted with heat resistant Aluminium paint (to be selected based on service condition of component as per IS-13183). Two coats of paint shall be applied with total DFT 40 micron.

(Vikas Malhotra)
(STE)

(S. K. Das)
(CIE)

0009E-07271-2
DRAWING No. 2-12320-36000

COPYRIGHT AND CONFIDENTIAL
THE INFORMATION ON THIS DOCUMENT IS THE PROPERTY OF BHARAT HEAVY ELECTRICALS LIMITED. IT MUST NOT BE USED DIRECTLY OR INDIRECTLY IN ANY WAY DETERIMENTAL TO THE INTEREST OF THE COMPANY.

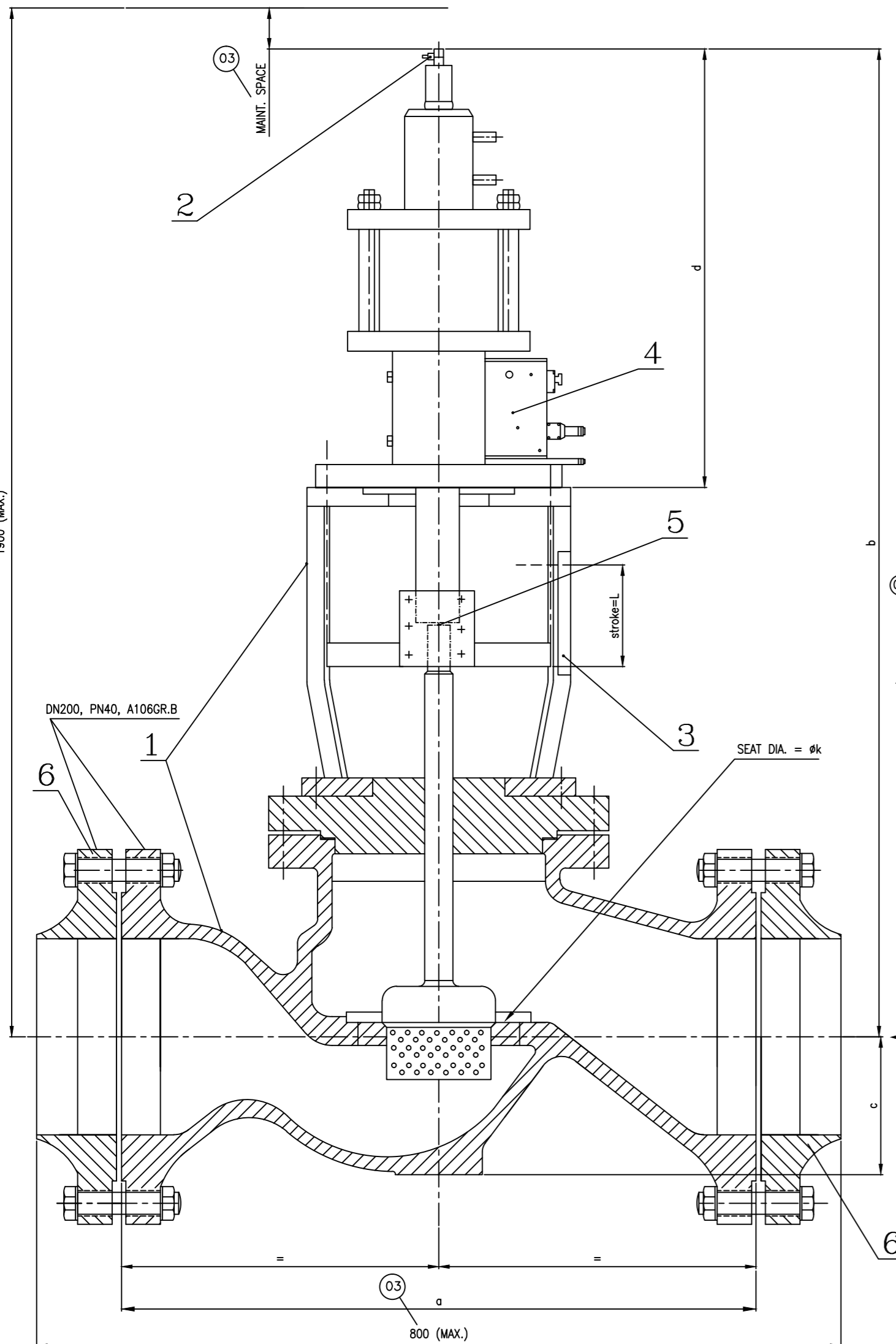

INPUT DATA FOR VALVE & ACTUATOR:

NO. OF VALVES WITH ACTUATOR	: TWO	(05)
MAX. CALCULATED WATER MASS FLOW	: 94.50 KG/SEC	(05)
MIN. CONTROLLED WATER MASS FLOW	: 12 KG/SEC	
MAX. WATER PRESSURE/TEMPERATURE	: 40 BAR / 100°C	
MAX. WATER PRESSURE ACROSS THE VALVE	: 34 BAR	(04)
WATER PRESSURE AT VALVE INLET	: 18.65 BAR	(04)
WATER INLET TEMPERATURE	: 30 TO 60°C	
NOISE REQUIREMENTS	: < 85 dB(A)	
INLET & OUTLET CONNECTIONS	: SHALL BE FLANGED END (AS SHOWN)	
SIZE AND MATL. OF PIPE FOR INLET/ OUTLET ENDS	: φ219.1x6.35 ASTM A106 GR:B	
VALVE SIZE	: DN 200	
ACTUATOR TYPE:	: ELECTRO-HYDRAULIC	
OPERATING MEDIUM	: FIRE RESISTANT FLUID (FRF)	
CONTROL FLUID NORMAL OPERATING PRESSURE	: 160 BAR (*)	
CONTROL FLUID MINIMUM OPERATING PRESSURE	: 115 BAR (*)	
NORMAL CONTROL FLUID TEMPERATURE	: 50+5°C	
MAXIMUM CONTROL FLUID TEMPERATURE	: 75°C	
CONTROL SIGNAL	: 4 TO 20mA/±30mA	
OPENING TIME	: <=3 SEC. (MAX.)	
ACTUATOR SPINDLE MOUNTING	: VERTICAL	
WATER FLOW TO BE REGULATED	: AS PER TABLE-1	
VALVE CHARACTERISTICS	: EQUAL PERCENTAGE	
FAILURE MODE	: STAY PUT	

(*) - HYDRAULIC OPERATING PRESSURE SHALL BE MADE AVAILABLE FROM THE CENTRALISED HYDRAULIC POWER SUPPLY UNIT (HPSU). MEANT FOR TURBINE BYPASS SYSTEM.

NOTES:-

1. ACTUATOR FLANGE END CONNECTIONS:

SUPPLY LINE : φ26.7X3.91, MATERIAL AS PER ASTM A312, GRADE TP321
RETURN LINE : φ33.4X2.60, MATERIAL AS PER ASTM A312, GRADE TP321

2. VALVE INLET & OUTLET COUNTER FLANGE END CONNECTIONS:

φ219.1X6.35, MATERIAL AS PER ASTM A105 (04)

TECHNICAL REQUIREMENTS:-

- VALVE TO BE SUPPLIED ALONG WITH INLET / OUTLET COUNTER FLANGES PREFERABLY IN C22.8 (1.0460) MATERIAL (WELD NECK, RAISED TYPE), ASSOCIATED FASTENERS AND SEALINGS
- SCOPE OF SUPPLY SHALL BE AS PER TABLE-2 (04)
- BODY MATERIAL : GS-C25 (CAST STEEL 1.0619)/ASTM A216WCB
- VALVE SUPPLIER MUST SHOW THE WATER FLOW DIRECTION WITH AN ARROW EMBOSSED OVER THE VALVE BODY.
- THE ACTUATOR SHALL BE CAPABLE OF MANUAL OPERATION & TO BE PROVIDED WITH HAND WHEEL.
- CONTROL BLOCK/MANIFOLD SHOULD BE MOUNTED ON THE POWER CYLINDER AND IT SHOULD CONSIST OF SERVO-VALVE, FILTER, SOLENOID VALVES, CARTRIDGES/CHECK VALVES ETC.
- ELECTRONIC POSITION FEEDBACK TRANSMITTER SHALL BE NON-CONTACT TYPE REQUIRED FOR MEASURING THE POSITION OF THE CONTROL VALVE. OUTPUT OF THE POSITION TRANSMITTER SHALL BE 4mA (VALVE FULLY CLOSED) TO 20mA (VALVE FULLY OPENED).
- VALVE BODY SHALL BE HYDRAULICALLY TESTED AT MIN. 1.5 TIMES DESIGN PRESSURE AS PER DIN 3230 PT III BA/BQ/ANSI B16.34.
- STRENGTH & LEAK TIGHTNESS TEST : AS PER CLASS V ANSI B 16.104. (04)

DOCUMENTS REQUIRED ALONG WITH THE OFFER ARE:-

- VALVE DATA SHEET INDICATING THEREIN ALL PARAMETERS, MATERIAL DETAIL ETC.
- GENERAL ARRANGEMENT DRAWING OF VALVE WITH ACTUATOR INDICATING THEREIN MAJOR DIMENSIONS, DISMANTLING DIMENSIONS & ASSEMBLY WEIGHT.
- DRAWING FOR VALVE & ACTUATOR COUPLING ARRANGEMENT
- HYDRAULIC ACTUATOR SCHEME INDICATING THEREIN PART NUMBERS.
- OPERATION & MAINTAINENCE INSTRUCTION/MANUAL.
- DATA SHEETS FOR ALL THE ITEMS MOUNTED ON THE CONTROL MANIFOLD. FURNISH THE WIRING DIAGRAM FOR ELECTRICAL ITEMS ALSO.
- LIST OF ALL RECOMMENDED SPARES FOR VALVE & ACTUATOR.
- BILL OF MATERIAL MUST BE TABULATED ON THE ASSEMBLY DRAWING.
- MATERIAL DETAIL OF THE COUNTER FLANGES TO BE FURNISHED.
- SIZING CALCULATION FOR VALVE & ACTUATOR
- QUALITY PLAN

Table-1 (05)

FLOW PARAMETERS (CASES SHALL BE AS DEFINED IN DRG. NO.31230036000 SH-1)	CHARACTERISTICS-EQUAL PERCENTAGE				
	CASE-1	CASE-2	CASE-3	CASE-4	CASE-5
WATER PRESSURE AT THE OUTLET OF W.I.V. (bar)	13.68	10.28	6.34	6.76	15.48
TOTAL QTY. OF WATER MASS FLOW TO BE REGULATED THRU' W.I.V. (Kg/Sec)	71.85	34.20	13.20	29.30	94.50

Table-2 (03)

IT.NOS.	ITEM DESCRIPTION
1.	CONTROL VALVE WITH HYDRAULIC ACTUATOR
2.	POSITION TRANSMITTER
3.	SCALE FOR LOCALISED DISPLAY
4.	CONTROL MANIFOLD
5.	COUPLING
6.	COUNTER FLANGES WITH FASTENERS
7.	COMMISSIONING SPARES

MAT. CODE : W90312320078

NOTE : - ALL DIMENSIONS AS MARKED SHALL BE FURNISHED BY THE SUPPLIER

REV	DATE	ALTERED CHECKED	REV	DATE	ALTERED CHECKED	REV	DATE	ALTERED CHECKED	REV	DATE	ALTERED CHECKED	REV	DATE	ALTERED CHECKED
05	12.12.14	UVERMA sd/- VIKAS sd/-	04	29.08.12	LOKESH sd/- VIKAS sd/-	03	09.04.10	UVERMA sd/- VIKAS sd/-	02	22.09.09	UVERMA sd/- VIKAS sd/-	01	09.04.09	UVERMA sd/- VIKAS sd/-
		CHANGED AS PER CHANGE ADVICE NO. STE-14-F0389.			CHANGED AS PER CHANGE ADVICE NO. STE-12-F0341.			CHANGED AS PER CHANGE ADVICE NO. STE-10-F0099.					THIS DRG. SUPERSEDES THE OLD DRG. UNDER THE SAME NO. WITH CHANGES AS PER CHANGE ADVICE NO. STE-09-F0301.	

GRADE OF UNTOL.DIM		-GMS No- / CBOM No.		STATUS OF DRG	
M/CG.-φ/M/f	AA0230208	AGREED DEPT	NAME	SIGN	DATE
WELDING-A/B/C/D	AA0621104	CIE	K.B.BATRA	-sd-	28.03.07
GAS CUTTING-T3	AA0621104	HXE	S.BARAI	-sd-	28.03.07

TYPE OF PRODUCT OR NAME OF CUSTOMER/PROJECT: STEAM TURBINE

BHARAT HEAVY ELECTRICALS LTD. RANIPUR, HARDWAR

DRN	VIJAY	SIGN	-sd-	DATE	28.03.07	No. OF VAR -
CHD	AMIT	SIGN	-sd-	DATE	28.03.07	
APPD	R.GULATI	SIGN	-sd-	DATE	28.03.07	

DEPT STE CODE 4011

SCALE NTS

WEIGHT (KG) 400.0

REF. TO ASSY. DRG. -

ITEM No. -

No. OF ITEMS 75-77

TITLE : WATER INJECTION VALVE WITH ACTUATOR

CARD CODE

DRAWING NO. 2-12320-36000

SHEET No. 01 No. OF SHEETS 01

DRAWING No. 3-12300-36100

SCOPE OF SUPPLY:-

S.NO.	ITEM DESCRIPTION	QTY.	UNIT
01.	STEAM BLOWING DEVICE FOR LP BYPASS VALVE	2	SET
02.	HYDRAULIC TEST DEVICE FOR LP BYPASS VALVE	2	SET
03.	ASSEMBLY AND DISASSEMBLY DEVICES	1	SET
04.	FLUSHING DEVICE FOR CONTROL FLUID SYSTEM	1	SET
05.	FILLING AND GAUGING DEVICES FOR HYDRAULIC ACCUMULATOR	1	NO
06.	MANUALLY OPERATED PUMP FOR FILLING OF CONTROL FLUID IN THE TANK OF HPSU	1	NO
07.	SPECIAL TOOLS AND TACKLES AS PER CLAUSE NO. 8.0 OF ST 47050	1	SET

COPYRIGHT AND CONFIDENTIAL
THE INFORMATION ON THIS DOCUMENT IS THE PROPERTY OF BHARAT HEAVY ELECTRICALS LIMITED. IT MUST NOT BE USED DIRECTLY OR INDIRECTLY IN ANY WAY DETERIMENTAL TO THE INTEREST OF THE COMPANY.

MAT. CODE : W90312300433

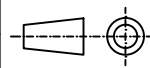
Ref. Drawing No >	GMS No. / C B O M		STATUS OF DRG		TYPE OF PRODUCT		STEAM TURBINE				
	AGREED DEPT	NAME	SIGN	DATE	OR		NAME OF CUSTOMER/PROJECT				
Sign & Date	GRADE OF UNTOL. DIM				 BHARAT HEAVY ELECTRICALS LTD. RANIPUR, HARDWAR	DRN	NAME	SIGN	DATE	NO. OF VAR	
	M/CG.- AA0230208 m					CHD	UVERMA	-SD-	26.11.14		-
	WELDING CLASS 'B' OF AA0621104					APPD	AKS/VM	-SD-	26.11.14		-
Inventory No.	GAS CUTTING-TABLE 3 OF AA0621104				DEPT	STE	SCALE	WEIGHT (KG)	REF. TO ASSY. DRG.	ITEM No.	NO. OF ITEMS
	REV	DATE	ALTERED	CHECKED	REV	DATE	ALTERED	CHECKED	---	---	---
						CODE	4011	 NTS	---	---	73 74
						TITLE : TOOL KIT FOR LP BYPASS SYSTEM		CARD CODE	DRAWING NO. 3-12300-36100		---
								7	22	23	24
								SHEET No. 2		No. OF SHEETS 2	

THE INFORMATION ON THIS DOCUMENT IS THE PROPERTY OF BHARAT HEAVY ELECTRICALS LIMITED. IT MUST NOT BE USED DIRECTLY OR INDIRECTLY IN ANY WAY DETERIMENTAL TO THE INTEREST OF THE COMPANY.

C119C-00C21-C

NO. DRAWING

FIRST ANGLE PROJECTION

(ALL DIMENSIONS ARE IN mm)

FORM DG 38(6)

LIST OF MANDATORY SPARES AS PER CLAUSE NO.1.1.2 OF ST47050:-

S.NO.	CLAUSE NO.	ITEM DESCRIPTION	QTY.	UNIT
01.	1.10.06	SERVO VALVE FOR LP BYPASS CONTROL VALVE SERVO VALVE FOR WATER INJECTION VALVE	02	NO.
02.	1.10.10	SOLENOID VALVE OF EACH TYPE AND MODULE	02	NO.

S.NO.	ITEM DESCRIPTION	QTY.	UNIT
	C & I SPARES		
01.	PRESSURE TRANSMITTER	01	NO.
02.	LEVEL TRANSMITTER	01	NO.
03.	RESISTANCE TEMPERATURE DETECTOR	02	NO.
04.	PRESSURE SWITCH	02 EACH TYPE	NO.
05.	DIFFERENTIAL PRESSURE SWITCH	02 EACH TYPE	NO.
06.	PRESSURE GAUGE	02 EACH TYPE	NO.
07.	LEVEL GAUGE	02	NO.
08.	LIMIT SWITCH	04	NO.
09.	POSITION TRANSMITTER (2 TYPES) 2 FOR LPBP CV + 2 FOR WATER INJECTION VALVE	04	NO.

TECHNICAL REQUIREMENTS :-

1. ALL THE MANDATORY SPARES SHALL BE MANUFACTURED & SUPPLIED CORRESPONDING TO THE MAIN EQUIPMENT.
2. INTERCHANGEABILITY OF ALL THE SPARES WITH THEIR RESPECTIVE PARTS FOR WHICH THEY ARE INTENDED FOR REPLACEMENTS, SHALL BE ENSURED BY THE SUPPLIER.
3. ALL THE SPARES MUST BE PACKED IN SEALED TRANSPARENT PLASTIC BAGS AND CLEARLY MARKED OR LABELED ON THE OUTSIDE OF THE PACKING WITH ITS DESCRIPTION & ASSEMBLY PART NUMBERS.
4. QUALITY CHECKS & TESTING NORMS/REQUIREMENTS FOR SPARES SHALL BE AS PER APPROVED QUALITY PLAN (QP) APPLICABLE FOR THE MAIN EQUIPMENT.
5. ALL THE RELEVANT ASSEMBLY DRGS. SHALL BE FURNISHED BY THE VENDOR MARKING ALL THE OFFERED ITEMS.
6. OFFERED ITEMS SHALL BE CORRELATED WITH THE ITEMS MENTIONED IN THIS DRAWING & WITH RESPECTIVE BOM OF MAIN EQUIPMENT DRAWING.
7. MANDATORY SPARES ARE TO BE OFFERED CONSIDERING ALL INSTRUMENTS MOUNTED ON HPSU AS WELL AS ON ACTUATORS.

MAT. CODE : W99312300865

STEAM TURBINE

GMS No / - C B O M		STATUS OF DRG	
AGREED DEPT	NAME	SIGN	DATE
CIE	S.K.DAS	-SD-	21.11.2014
TYPE OF PRODUCT OR NAME OF CUSTOMER/PROJECT		BOM	
BHARAT HEAVY ELECTRICALS LTD. RANIPUR, HARDWAR		STEAM TURBINE	
DRN	U VERMA	-SD-	20.11.2014
CHD	AKS/VM	-SD-	20.11.2014
APPD	N. GARG	-SD-	21.11.2014
NO. OF VAR			
73			
74			

DEPT	STE	SCALE	WEIGHT (KG)	REF. TO ASSY. DRG.	ITEM NO.	NO. OF ITEMS
CODE	4011	NTS			75	74

TITLE :	MANDATORY SPARES FOR LP BYPASS SYSTEM	CARD CODE	DRAWING NO. 3-12300-36113
SHEET No.	1	No. OF SHEETS	1

Inventory No.	Sign & Date	Ref. Drawing No >
REV	DATE	REV
ALTERED	ALTERED	DATE
CHECKED	CHECKED	

31336041501

ON 9NIMV98/12012 2011

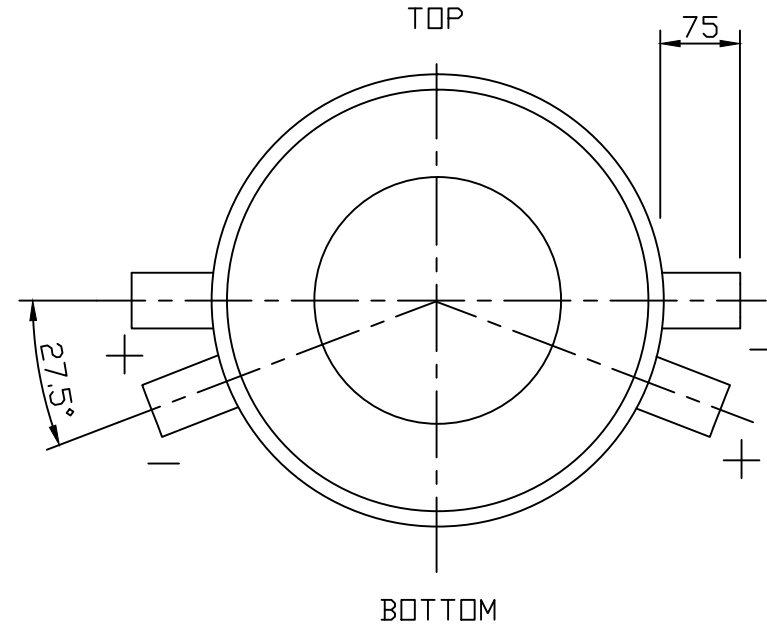
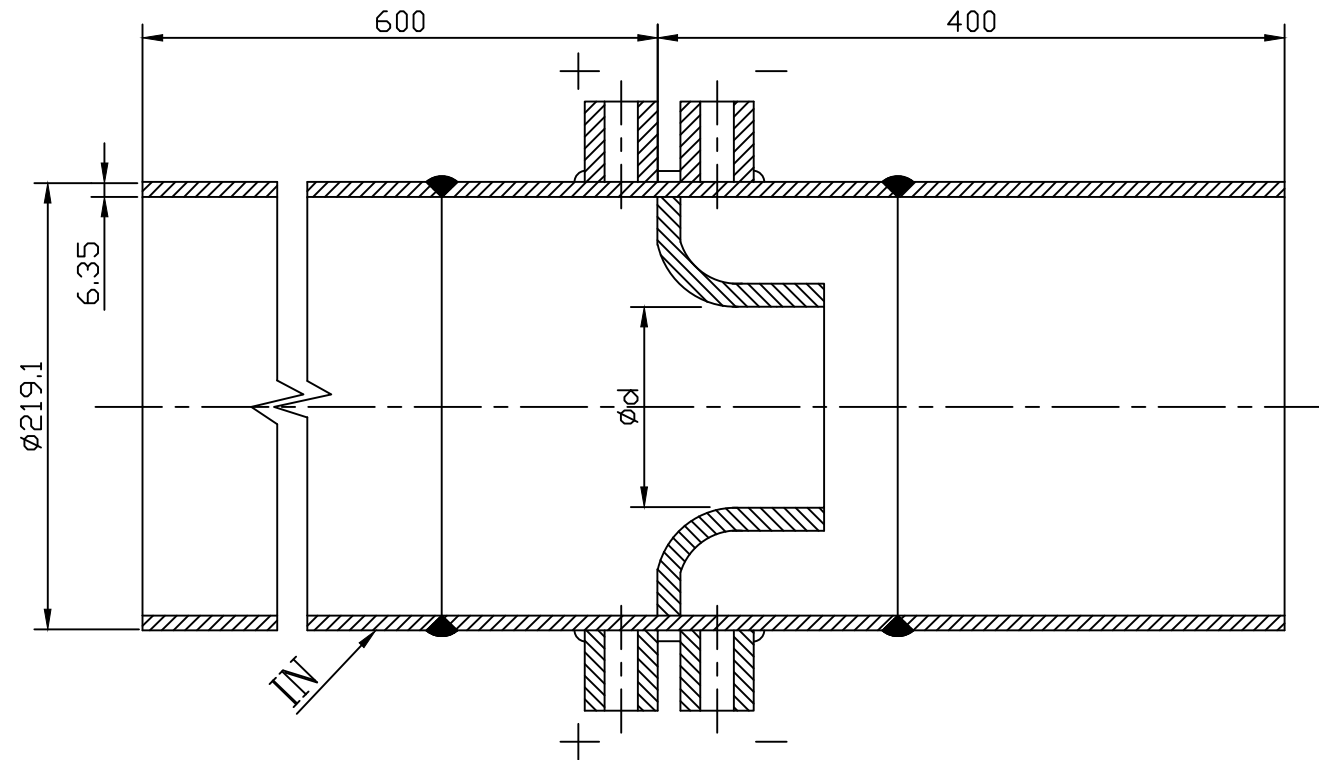

TECH.REQUIREMENTS:-

TYPE	WELD IN TYPE WITH CORNER TAP AS PER ISA 1932.
MATERIAL OF NOZZLE	15 MO 3
PIPE MATERIAL	ASTM A106 Gr.B
PIPE SIZE.....	219.1X6.35
MEDIUM.....	CONDENSATE
MAXIMUM FLOW	110 Kg/Sec.
OPERATING/DESIGN PRESS.....	20/30 KG/CM2
OPERATING/DESIGN TEMP.....	50/100°C
DIFFERENTIAL PRESSURE	Approx. 1500m BAR
(AT MAX. FLOW)	
TAPS	2+2 CORNER TAPS SUTABLE FOR PIPE SIZE 13.5x2.6
TAP LENGTH	75 MM

DOCUMENTS WITH THE OFFER

1. DESIGN CALCULATIONS.
2. DRG. OF THE FLOW NOZZLE.
3. FLOW VERSUS DIFFERENTIAL OF PRESSURE CURVE.

MATERIAL CODE :- W90313360359

असह्य विमाओं का वर्ग GRADE OF UNTOLERANCED DIMENSION		सी.वी.ओ.एम./C.B.O.M. CBOM-21336041500		अभिकल्प का स्तर STATUS OF DRG. U	उत्पाद का प्रकार या ग्राहक/परियोजना का नाम TYPE OF PRODUCT OR NAME OF CUSTOMER/PROJECT	स्टीम टरबाइन STEAM TURBINE						
मशीनिंग - एए0230208 एम MACHINING - AA0230208 m		सहमत विभाग AGREED DEPTT.	नाम/NAME	हस्ताक्षर/ SIGN.	दिनांक/DATE	नाम/NAME	हस्ताक्षर/SIGN	दिनांक/DATE	वैरिएंट संख्या No. of Var.			
वैल्डिंग - एए0621104 की श्रेणी बी WELDING-CLASS 'B' OF AA0621104		---	---	---	---	J.S.BHANDARI	-Sd-	21/05/2008				
गैस कटिंग - एए0621101 की श्रेणी 3 GAS CUTTING-TABLE 3 OF AA0621101						V.KUMAR	-Sd-	21/05/2008				
संशोधन REV.	दिनांक DATE	संशोधनकर्ता ALTERED BY जांचकर्ता CHD	संशोधन REV.	दिनांक DATE	संशोधनकर्ता ALTERED BY जांचकर्ता CHD	विभाग DEPTT.	स्टीम टरबाइन अभि. STE	माप/SCALE N.T.S.	भार कि.ग्रा. WEIGHT (KG) 22.00	असेम्बली अभिकल्प का संदर्भ REFER TO ASSLY. DRG. 21336041500	नग क्रमांक ITEM NO. --	सभी की संख्या NO. OF ITEMS 01
शीर्षक/TITLE FLOW NOZZLE FOR WIV						कार्ड कूट CARD CODE 7	अभिकल्प संख्या/DRAWING NO. 31336041501		पृष्ठ संख्या/Sheets No. 01	पृष्ठों की संख्या/No. of Sheets 01		

COPYRIGHT AND CONFIDENTIAL THE INFORMATION ON THIS DOCUMENT IS THE PROPERTY OF BHARAT HEAVY ELECTRICALS LIMITED. IT MUST NOT BE USED DIRECTLY OR INDIRECTLY IN ANY WAY DETERIMENTAL TO THE INTEREST OF THE COMPANY.

स्वाधिकार एवं गोपनीय इस प्रोजेक्ट में दी गई सूचना भारत हेवी इलेक्ट्रिकल्स लिमिटेड की संपत्ति है। इसका प्रत्यक्ष या अप्रत्यक्ष रूप में किसी भी तरह प्रयोग नहीं किया जाए जो कम्पनी के हित में हानिकारक हो।

संदर्भित अभिकल्प संख्या
REFERENCE DRG. NO.

हस्ताक्षर और दिनांक/SIGN & DATE

सामग्री सूची संख्या
INVENTORY NO.

50095-00621-3

no. DRAWING

FIRST ANGLE PROJECTION

(ALL DIMENSIONS ARE IN mm)

FORM DC 38(6)

COPYRIGHT AND CONFIDENTIAL

THE INFORMATION ON THIS DOCUMENT IS THE PROPERTY OF BHARAT HEAVY ELECTRICALS LIMITED. IT MUST NOT BE USED DIRECTLY OR INDIRECTLY IN ANY WAY DETERIMENTAL TO THE INTEREST OF THE COMPANY.

SL.NO.	QUANTITY	DESCRIPTION
A-HYDRAULIC POWER SUPPLY UNIT:		
1	2 NO. (EACH TYPE)	FILTER INSERT FOR EACH TYPE OF FILTER IN HPSU.
2	1 SET (EACH TYPE)	O-RINGS, GASKETS, SEALING & PACKING (EACH TYPE) IN HPSU.
B-ELECTRO HYDRAULIC ACTUATORS:		
1	2 NO. (EACH TYPE)	FILTER INSERT FOR EACH TYPE OF FILTER IN ELECTRO-HYDRAULIC ACTUATORS.
2	1 SET (EACH TYPE)	O-RINGS, GASKETS, SEALING & PACKING (EACH TYPE) IN ELECTRO-HYDRAULIC ACTUATORS.
3	1 SET (EACH TYPE)	RECEPTACLE CONNECTORS
C-LP BYPASS STOP VALVE, LP BYPASS CONTROL VALVE AND WATER INJECTION CONTROL VALVE:		
1	1 SET (EACH TYPE)	O-RINGS, GASKETS, SEALING & PACKING (EACH TYPE) IN VALVES.
D-C&I ITEMS:		
1	1 NO. (EACH TYPE)	POSITION TRANSMITTERS
E-OTHER ITEMS OFFERED BY THE VENDOR AS PER THEIR STANDARD PRACTICE.		

- NOTES:**
- SUPPLIER TO FURNISH THE RELEVANT BILL OF MATERIAL & EQUIPMENTS DRAWING ALONG WITH THE OFFER CORRELATING EACH OF ABOVE REFERRED ITEMS.
 - THE VENDOR TO OFFER THE COMMISSIONING SPARES TAKING CARE OF UNINTERRUPTED OPERATION OF LP BYPASS SYSTEM FOR ONE YEAR.

Inventory No.	Sign & Date	Ref. Drawing No.	1																													
REV	DATE	ALTERED	REV	DATE																												
		CHECKED																														
<table border="1"> <tr> <td>GRADE OF UNTOL. DIM</td> <td>CIE</td> <td>AGREED BY</td> <td>NAME</td> <td>SIGN</td> <td>DATE</td> <td>STATUS OF DRG</td> </tr> <tr> <td>M/CG.- AA0230208 m</td> <td></td> <td></td> <td>S.SINGH</td> <td>-sd-</td> <td>17.06.13</td> <td></td> </tr> <tr> <td>WELDING-CLASS 'B' OF AA0621104</td> <td></td> <td></td> <td></td> <td></td> <td></td> <td></td> </tr> <tr> <td>GAS CUTTING-TABLE 3 OF AA0621101</td> <td></td> <td></td> <td></td> <td></td> <td></td> <td></td> </tr> </table>					GRADE OF UNTOL. DIM	CIE	AGREED BY	NAME	SIGN	DATE	STATUS OF DRG	M/CG.- AA0230208 m			S.SINGH	-sd-	17.06.13		WELDING-CLASS 'B' OF AA0621104							GAS CUTTING-TABLE 3 OF AA0621101						
GRADE OF UNTOL. DIM	CIE	AGREED BY	NAME	SIGN	DATE	STATUS OF DRG																										
M/CG.- AA0230208 m			S.SINGH	-sd-	17.06.13																											
WELDING-CLASS 'B' OF AA0621104																																
GAS CUTTING-TABLE 3 OF AA0621101																																
<table border="1"> <tr> <td>DEPT</td> <td>STE</td> <td>SCALE</td> <td>WEIGHT (KG)</td> <td>REF. TO ASSY. DRG.</td> <td>ITEM NO.</td> <td>NO. OF ITEMS</td> </tr> <tr> <td>4011</td> <td></td> <td>N.T.S</td> <td>-</td> <td>-</td> <td>75</td> <td>77</td> </tr> </table>					DEPT	STE	SCALE	WEIGHT (KG)	REF. TO ASSY. DRG.	ITEM NO.	NO. OF ITEMS	4011		N.T.S	-	-	75	77														
DEPT	STE	SCALE	WEIGHT (KG)	REF. TO ASSY. DRG.	ITEM NO.	NO. OF ITEMS																										
4011		N.T.S	-	-	75	77																										
<table border="1"> <tr> <td>DRN</td> <td>SS/DK</td> <td>SIGN</td> <td>DATE</td> <td>NO. OF</td> </tr> <tr> <td>CHD</td> <td>LS/RR</td> <td>-sd-</td> <td>01.06.13</td> <td>VAR</td> </tr> <tr> <td>Appd</td> <td>R.C.A</td> <td>-sd-</td> <td>10.06.13</td> <td>73</td> </tr> <tr> <td></td> <td></td> <td></td> <td></td> <td>74</td> </tr> </table>					DRN	SS/DK	SIGN	DATE	NO. OF	CHD	LS/RR	-sd-	01.06.13	VAR	Appd	R.C.A	-sd-	10.06.13	73					74								
DRN	SS/DK	SIGN	DATE	NO. OF																												
CHD	LS/RR	-sd-	01.06.13	VAR																												
Appd	R.C.A	-sd-	10.06.13	73																												
				74																												
<table border="1"> <tr> <td>DEPT</td> <td>STE</td> <td>SCALE</td> <td>WEIGHT (KG)</td> <td>REF. TO ASSY. DRG.</td> <td>ITEM NO.</td> <td>NO. OF ITEMS</td> </tr> <tr> <td>4011</td> <td></td> <td>N.T.S</td> <td>-</td> <td>-</td> <td>75</td> <td>77</td> </tr> </table>					DEPT	STE	SCALE	WEIGHT (KG)	REF. TO ASSY. DRG.	ITEM NO.	NO. OF ITEMS	4011		N.T.S	-	-	75	77														
DEPT	STE	SCALE	WEIGHT (KG)	REF. TO ASSY. DRG.	ITEM NO.	NO. OF ITEMS																										
4011		N.T.S	-	-	75	77																										
<table border="1"> <tr> <td>DRN</td> <td>SS/DK</td> <td>SIGN</td> <td>DATE</td> <td>NO. OF</td> </tr> <tr> <td>CHD</td> <td>LS/RR</td> <td>-sd-</td> <td>01.06.13</td> <td>VAR</td> </tr> <tr> <td>Appd</td> <td>R.C.A</td> <td>-sd-</td> <td>10.06.13</td> <td>73</td> </tr> <tr> <td></td> <td></td> <td></td> <td></td> <td>74</td> </tr> </table>					DRN	SS/DK	SIGN	DATE	NO. OF	CHD	LS/RR	-sd-	01.06.13	VAR	Appd	R.C.A	-sd-	10.06.13	73					74								
DRN	SS/DK	SIGN	DATE	NO. OF																												
CHD	LS/RR	-sd-	01.06.13	VAR																												
Appd	R.C.A	-sd-	10.06.13	73																												
				74																												
<table border="1"> <tr> <td>DRN</td> <td>SS/DK</td> <td>SIGN</td> <td>DATE</td> <td>NO. OF</td> </tr> <tr> <td>CHD</td> <td>LS/RR</td> <td>-sd-</td> <td>01.06.13</td> <td>VAR</td> </tr> <tr> <td>Appd</td> <td>R.C.A</td> <td>-sd-</td> <td>10.06.13</td> <td>73</td> </tr> <tr> <td></td> <td></td> <td></td> <td></td> <td>74</td> </tr> </table>					DRN	SS/DK	SIGN	DATE	NO. OF	CHD	LS/RR	-sd-	01.06.13	VAR	Appd	R.C.A	-sd-	10.06.13	73					74								
DRN	SS/DK	SIGN	DATE	NO. OF																												
CHD	LS/RR	-sd-	01.06.13	VAR																												
Appd	R.C.A	-sd-	10.06.13	73																												
				74																												
<table border="1"> <tr> <td>DRN</td> <td>SS/DK</td> <td>SIGN</td> <td>DATE</td> <td>NO. OF</td> </tr> <tr> <td>CHD</td> <td>LS/RR</td> <td>-sd-</td> <td>01.06.13</td> <td>VAR</td> </tr> <tr> <td>Appd</td> <td>R.C.A</td> <td>-sd-</td> <td>10.06.13</td> <td>73</td> </tr> <tr> <td></td> <td></td> <td></td> <td></td> <td>74</td> </tr> </table>					DRN	SS/DK	SIGN	DATE	NO. OF	CHD	LS/RR	-sd-	01.06.13	VAR	Appd	R.C.A	-sd-	10.06.13	73					74								
DRN	SS/DK	SIGN	DATE	NO. OF																												
CHD	LS/RR	-sd-	01.06.13	VAR																												
Appd	R.C.A	-sd-	10.06.13	73																												
				74																												
<table border="1"> <tr> <td>DRN</td> <td>SS/DK</td> <td>SIGN</td> <td>DATE</td> <td>NO. OF</td> </tr> <tr> <td>CHD</td> <td>LS/RR</td> <td>-sd-</td> <td>01.06.13</td> <td>VAR</td> </tr> <tr> <td>Appd</td> <td>R.C.A</td> <td>-sd-</td> <td>10.06.13</td> <td>73</td> </tr> <tr> <td></td> <td></td> <td></td> <td></td> <td>74</td> </tr> </table>					DRN	SS/DK	SIGN	DATE	NO. OF	CHD	LS/RR	-sd-	01.06.13	VAR	Appd	R.C.A	-sd-	10.06.13	73					74								
DRN	SS/DK	SIGN	DATE	NO. OF																												
CHD	LS/RR	-sd-	01.06.13	VAR																												
Appd	R.C.A	-sd-	10.06.13	73																												
				74																												
<table border="1"> <tr> <td>DRN</td> <td>SS/DK</td> <td>SIGN</td> <td>DATE</td> <td>NO. OF</td> </tr> <tr> <td>CHD</td> <td>LS/RR</td> <td>-sd-</td> <td>01.06.13</td> <td>VAR</td> </tr> <tr> <td>Appd</td> <td>R.C.A</td> <td>-sd-</td> <td>10.06.13</td> <td>73</td> </tr> <tr> <td></td> <td></td> <td></td> <td></td> <td>74</td> </tr> </table>					DRN	SS/DK	SIGN	DATE	NO. OF	CHD	LS/RR	-sd-	01.06.13	VAR	Appd	R.C.A	-sd-	10.06.13	73					74								
DRN	SS/DK	SIGN	DATE	NO. OF																												
CHD	LS/RR	-sd-	01.06.13	VAR																												
Appd	R.C.A	-sd-	10.06.13	73																												
				74																												
<table border="1"> <tr> <td>DRN</td> <td>SS/DK</td> <td>SIGN</td> <td>DATE</td> <td>NO. OF</td> </tr> <tr> <td>CHD</td> <td>LS/RR</td> <td>-sd-</td> <td>01.06.13</td> <td>VAR</td> </tr> <tr> <td>Appd</td> <td>R.C.A</td> <td>-sd-</td> <td>10.06.13</td> <td>73</td> </tr> <tr> <td></td> <td></td> <td></td> <td></td> <td>74</td> </tr> </table>					DRN	SS/DK	SIGN	DATE	NO. OF	CHD	LS/RR	-sd-	01.06.13	VAR	Appd	R.C.A	-sd-	10.06.13	73					74								
DRN	SS/DK	SIGN	DATE	NO. OF																												
CHD	LS/RR	-sd-	01.06.13	VAR																												
Appd	R.C.A	-sd-	10.06.13	73																												
				74																												
<table border="1"> <tr> <td>DRN</td> <td>SS/DK</td> <td>SIGN</td> <td>DATE</td> <td>NO. OF</td> </tr> <tr> <td>CHD</td> <td>LS/RR</td> <td>-sd-</td> <td>01.06.13</td> <td>VAR</td> </tr> <tr> <td>Appd</td> <td>R.C.A</td> <td>-sd-</td> <td>10.06.13</td> <td>73</td> </tr> <tr> <td></td> <td></td> <td></td> <td></td> <td>74</td> </tr> </table>					DRN	SS/DK	SIGN	DATE	NO. OF	CHD	LS/RR	-sd-	01.06.13	VAR	Appd	R.C.A	-sd-	10.06.13	73					74								
DRN	SS/DK	SIGN	DATE	NO. OF																												
CHD	LS/RR	-sd-	01.06.13	VAR																												
Appd	R.C.A	-sd-	10.06.13	73																												
				74																												
<table border="1"> <tr> <td>DRN</td> <td>SS/DK</td> <td>SIGN</td> <td>DATE</td> <td>NO. OF</td> </tr> <tr> <td>CHD</td> <td>LS/RR</td> <td>-sd-</td> <td>01.06.13</td> <td>VAR</td> </tr> <tr> <td>Appd</td> <td>R.C.A</td> <td>-sd-</td> <td>10.06.13</td> <td>73</td> </tr> <tr> <td></td> <td></td> <td></td> <td></td> <td>74</td> </tr> </table>					DRN	SS/DK	SIGN	DATE	NO. OF	CHD	LS/RR	-sd-	01.06.13	VAR	Appd	R.C.A	-sd-	10.06.13	73					74								
DRN	SS/DK	SIGN	DATE	NO. OF																												
CHD	LS/RR	-sd-	01.06.13	VAR																												
Appd	R.C.A	-sd-	10.06.13	73																												
				74																												
<table border="1"> <tr> <td>DRN</td> <td>SS/DK</td> <td>SIGN</td> <td>DATE</td> <td>NO. OF</td> </tr> <tr> <td>CHD</td> <td>LS/RR</td> <td>-sd-</td> <td>01.06.13</td> <td>VAR</td> </tr> <tr> <td>Appd</td> <td>R.C.A</td> <td>-sd-</td> <td>10.06.13</td> <td>73</td> </tr> <tr> <td></td> <td></td> <td></td> <td></td> <td>74</td> </tr> </table>					DRN	SS/DK	SIGN	DATE	NO. OF	CHD	LS/RR	-sd-	01.06.13	VAR	Appd	R.C.A	-sd-	10.06.13	73					74								
DRN	SS/DK	SIGN	DATE	NO. OF																												
CHD	LS/RR	-sd-	01.06.13	VAR																												
Appd	R.C.A	-sd-	10.06.13	73																												
				74																												
<table border="1"> <tr> <td>DRN</td> <td>SS/DK</td> <td>SIGN</td> <td>DATE</td> <td>NO. OF</td> </tr> <tr> <td>CHD</td> <td>LS/RR</td> <td>-sd-</td> <td>01.06.13</td> <td>VAR</td> </tr> <tr> <td>Appd</td> <td>R.C.A</td> <td>-sd-</td> <td>10.06.13</td> <td>73</td> </tr> <tr> <td></td> <td></td> <td></td> <td></td> <td>74</td> </tr> </table>					DRN	SS/DK	SIGN	DATE	NO. OF	CHD	LS/RR	-sd-	01.06.13	VAR	Appd	R.C.A	-sd-	10.06.13	73					74								
DRN	SS/DK	SIGN	DATE	NO. OF																												
CHD	LS/RR	-sd-	01.06.13	VAR																												
Appd	R.C.A	-sd-	10.06.13	73																												
				74																												
<table border="1"> <tr> <td>DRN</td> <td>SS/DK</td> <td>SIGN</td> <td>DATE</td> <td>NO. OF</td> </tr> <tr> <td>CHD</td> <td>LS/RR</td> <td>-sd-</td> <td>01.06.13</td> <td>VAR</td> </tr> <tr> <td>Appd</td> <td>R.C.A</td> <td>-sd-</td> <td>10.06.13</td> <td>73</td> </tr> <tr> <td></td> <td></td> <td></td> <td></td> <td>74</td> </tr> </table>					DRN	SS/DK	SIGN	DATE	NO. OF	CHD	LS/RR	-sd-	01.06.13	VAR	Appd	R.C.A	-sd-	10.06.13	73					74								
DRN	SS/DK	SIGN	DATE	NO. OF																												
CHD	LS/RR	-sd-	01.06.13	VAR																												
Appd	R.C.A	-sd-	10.06.13	73																												
				74																												
<table border="1"> <tr> <td>DRN</td> <td>SS/DK</td> <td>SIGN</td> <td>DATE</td> <td>NO. OF</td> </tr> <tr> <td>CHD</td> <td>LS/RR</td> <td>-sd-</td> <td>01.06.13</td> <td>VAR</td> </tr> <tr> <td>Appd</td> <td>R.C.A</td> <td>-sd-</td> <td>10.06.13</td> <td>73</td> </tr> <tr> <td></td> <td></td> <td></td> <td></td> <td>74</td> </tr> </table>					DRN	SS/DK	SIGN	DATE	NO. OF	CHD	LS/RR	-sd-	01.06.13	VAR	Appd	R.C.A	-sd-	10.06.13	73					74								
DRN	SS/DK	SIGN	DATE	NO. OF																												
CHD	LS/RR	-sd-	01.06.13	VAR																												
Appd	R.C.A	-sd-	10.06.13	73																												
				74																												
<table border="1"> <tr> <td>DRN</td> <td>SS/DK</td> <td>SIGN</td> <td>DATE</td> <td>NO. OF</td> </tr> <tr> <td>CHD</td> <td>LS/RR</td> <td>-sd-</td> <td>01.06.13</td> <td>VAR</td> </tr> <tr> <td>Appd</td> <td>R.C.A</td> <td>-sd-</td> <td>10.06.13</td> <td>73</td> </tr> <tr> <td></td> <td></td> <td></td> <td></td> <td>74</td> </tr> </table>					DRN	SS/DK	SIGN	DATE	NO. OF	CHD	LS/RR	-sd-	01.06.13	VAR	Appd	R.C.A	-sd-	10.06.13	73					74								
DRN	SS/DK	SIGN	DATE	NO. OF																												
CHD	LS/RR	-sd-	01.06.13	VAR																												
Appd	R.C.A	-sd-	10.06.13	73																												
				74																												
<table border="1"> <tr> <td>DRN</td> <td>SS/DK</td> <td>SIGN</td> <td>DATE</td> <td>NO. OF</td> </tr> <tr> <td>CHD</td> <td>LS/RR</td> <td>-sd-</td> <td>01.06.13</td> <td>VAR</td> </tr> <tr> <td>Appd</td> <td>R.C.A</td> <td>-sd-</td> <td>10.06.13</td> <td>73</td> </tr> <tr> <td></td> <td></td> <td></td> <td></td> <td>74</td> </tr> </table>					DRN	SS/DK	SIGN	DATE	NO. OF	CHD	LS/RR	-sd-	01.06.13	VAR	Appd	R.C.A	-sd-	10.06.13	73					74								
DRN	SS/DK	SIGN	DATE	NO. OF																												
CHD	LS/RR	-sd-	01.06.13	VAR																												
Appd	R.C.A	-sd-	10.06.13	73																												
				74																												
<table border="1"> <tr> <td>DRN</td> <td>SS/DK</td> <td>SIGN</td> <td>DATE</td> <td>NO. OF</td> </tr> <tr> <td>CHD</td> <td>LS/RR</td> <td>-sd-</td> <td>01.06.13</td> <td>VAR</td> </tr> <tr> <td>Appd</td> <td>R.C.A</td> <td>-sd-</td> <td>10.06.13</td> <td>73</td> </tr> <tr> <td></td> <td></td> <td></td> <td></td> <td>74</td> </tr> </table>					DRN	SS/DK	SIGN	DATE	NO. OF	CHD	LS/RR	-sd-	01.06.13	VAR	Appd	R.C.A	-sd-	10.06.13	73					74								
DRN	SS/DK	SIGN	DATE	NO. OF																												
CHD	LS/RR	-sd-	01.06.13	VAR																												
Appd	R.C.A	-sd-	10.06.13	73																												
				74																												
<table border="1"> <tr> <td>DRN</td> <td>SS/DK</td> <td>SIGN</td> <td>DATE</td> <td>NO. OF</td> </tr> <tr> <td>CHD</td> <td>LS/RR</td> <td>-sd-</td> <td>01.06.13</td> <td>VAR</td> </tr> <tr> <td>Appd</td> <td>R.C.A</td> <td>-sd-</td> <td>10.06.13</td> <td>73</td> </tr> <tr> <td></td> <td></td> <td></td> <td></td> <td>74</td> </tr> </table>					DRN	SS/DK	SIGN	DATE	NO. OF	CHD	LS/RR	-sd-	01.06.13	VAR	Appd	R.C.A	-sd-	10.06.13	73					74								
DRN	SS/DK	SIGN	DATE	NO. OF																												
CHD	LS/RR	-sd-	01.06.13	VAR																												
Appd	R.C.A	-sd-	10.06.13	73																												
				74																												
<table border="1"> <tr> <td>DRN</td> <td>SS/DK</td> <td>SIGN</td> <td>DATE</td> <td>NO. OF</td> </tr> <tr> <td>CHD</td> <td>LS/RR</td> <td>-sd-</td> <td>01.06.13</td> <td>VAR</td> </tr> <tr> <td>Appd</td> <td>R.C.A</td> <td>-sd-</td> <td>10.06.13</td> <td>73</td> </tr> <tr> <td></td> <td></td> <td></td> <td></td> <td>74</td> </tr> </table>					DRN	SS/DK	SIGN	DATE	NO. OF	CHD	LS/RR	-sd-	01.06.13	VAR	Appd	R.C.A	-sd-	10.06.13	73					74								
DRN	SS/DK	SIGN	DATE	NO. OF																												
CHD	LS/RR	-sd-	01.06.13	VAR																												
Appd	R.C.A	-sd-	10.06.13	73																												
				74																												
<table border="1"> <tr> <td>DRN</td> <td>SS/DK</td> <td>SIGN</td> <td>DATE</td> <td>NO. OF</td> </tr> <tr> <td>CHD</td> <td>LS/RR</td> <td>-sd-</td> <td>01.06.13</td> <td>VAR</td> </tr> <tr> <td>Appd</td> <td>R.C.A</td> <td>-sd-</td> <td>10.06.13</td> <td>73</td> </tr> <tr> <td></td> <td></td> <td></td> <td></td> <td>74</td> </tr> </table>					DRN	SS/DK	SIGN	DATE	NO. OF	CHD	LS/RR	-sd-	01.06.13	VAR	Appd	R.C.A	-sd-	10.06.13	73					74								
DRN	SS/DK	SIGN	DATE	NO. OF																												
CHD	LS/RR	-sd-	01.06.13	VAR																												
Appd	R.C.A	-sd-	10.06.13	73																												
				74																												
<table border="1"> <tr> <td>DRN</td> <td>SS/DK</td> <td>SIGN</td> <td>DATE</td> <td>NO. OF</td> </tr> <tr> <td>CHD</td> <td>LS/RR</td> <td>-sd-</td> <td>01.06.13</td> <td>VAR</td> </tr> <tr> <td>Appd</td> <td>R.C.A</td> <td>-sd-</td> <td>10.06.13</td> <td>73</td> </tr> <tr> <td></td> <td></td> <td></td> <td></td> <td>74</td> </tr> </table>					DRN	SS/DK	SIGN	DATE	NO. OF	CHD	LS/RR	-sd-	01.06.13	VAR	Appd	R.C.A	-sd-	10.06.13	73					74								
DRN	SS/DK	SIGN	DATE	NO. OF																												
CHD	LS/RR	-sd-	01.06.13	VAR																												
Appd	R.C.A	-sd-	10.06.13	73																												
				74																												
<table border="1"> <tr> <td>DRN</td> <td>SS/DK</td> <td>SIGN</td> <td>DATE</td> <td>NO. OF</td> </tr> <tr> <td>CHD</td> <td>LS/RR</td> <td>-sd-</td> <td>01.06.13</td> <td>VAR</td> </tr> <tr> <td>Appd</td> <td>R.C.A</td> <td>-sd-</td> <td>10.06.13</td> <td>73</td> </tr> <tr> <td></td> <td></td> <td></td> <td></td> <td>74</td> </tr> </table>					DRN	SS/DK	SIGN	DATE	NO. OF	CHD	LS/RR	-sd-	01.06.13	VAR	Appd	R.C.A	-sd-	10.06.13	73					74								
DRN	SS/DK	SIGN	DATE	NO. OF																												
CHD	LS/RR	-sd-	01.06.13	VAR																												
Appd	R.C.A	-sd-	10.06.13	73																												
				74																												
<table border="1"> <tr> <td>DRN</td> <td>SS/DK</td> <td>SIGN</td> <td>DATE</td> <td>NO. OF</td> </tr> <tr> <td>CHD</td> <td>LS/RR</td> <td>-sd-</td> <td>01.06.13</td> <td>VAR</td> </tr> <tr> <td>Appd</td> <td>R.C.A</td> <td>-sd-</td> <td>10.06.13</td> <td>73</td> </tr> <tr> <td></td> <td></td> <td></td> <td></td> <td>74</td> </tr> </table>					DRN	SS/DK	SIGN	DATE	NO. OF	CHD	LS/RR	-sd-	01.06.13	VAR	Appd	R.C.A	-sd-	10.06.13	73					74								
DRN	SS/DK	SIGN	DATE	NO. OF																												
CHD	LS/RR	-sd-	01.06.13	VAR																												
Appd	R.C.A	-sd-	10.06.13	73																												
				74																												
<table border="1"> <tr> <td>DRN</td> <td>SS/DK</td> <td>SIGN</td> <td>DATE</td> <td>NO. OF</td> </tr> <tr> <td>CHD</td> <td>LS/RR</td> <td>-sd-</td> <td>01.06.13</td> <td>VAR</td> </tr> <tr> <td>Appd</td> <td>R.C.A</td> <td>-sd-</td> <td>10.06.13</td> <td>73</td> </tr> <tr> <td></td> <td></td> <td></td> <td></td> <td>74</td> </tr> </table>					DRN	SS/DK	SIGN	DATE	NO. OF	CHD	LS/RR	-sd-	01.06.13	VAR	Appd	R.C.A	-sd-	10.06.13	73					74								
DRN	SS/DK	SIGN	DATE	NO. OF																												
CHD	LS/RR	-sd-	01.06.13	VAR																												
Appd	R.C.A	-sd-	10.06.13	73																												
				74																												
<table border="1"> <tr> <td>DRN</td> <td>SS/DK</td> <td>SIGN</td> <td>DATE</td> <td>NO. OF</td> </tr> <tr> <td>CHD</td> <td>LS/RR</td> <td>-sd-</td> <td>01.06.13</td> <td>VAR</td> </tr> <tr> <td>Appd</td> <td>R.C.A</td> <td>-sd-</td> <td>10.06.13</td> <td>73</td> </tr> <tr> <td></td> <td></td> <td></td> <td></td> <td>74</td> </tr> </table>					DRN	SS/DK	SIGN	DATE	NO. OF	CHD	LS/RR	-sd-	01.06.13	VAR	Appd	R.C.A	-sd-	10.06.13	73					74								
DRN	SS/DK	SIGN	DATE	NO. OF																												
CHD	LS/RR	-sd-	01.06.13	VAR																												
Appd	R.C.A	-sd-	10.06.13	73																												
				74																												
<table border="1"> <tr> <td>DRN</td> <td>SS/DK</td> <td>SIGN</td> <td>DATE</td> <td>NO. OF</td> </tr> <tr> <td>CHD</td> <td>LS/RR</td> <td>-sd-</td> <td>01.06.13</td> <td>VAR</td> </tr> <tr> <td>Appd</td> <td>R.C.A</td> <td>-sd-</td> <td>10.06.13</td> <td>73</td> </tr> <tr> <td></td> <td></td> <td></td> <td></td> <td>74</td> </tr> </table>					DRN	SS/DK	SIGN	DATE	NO. OF	CHD	LS/RR	-sd-	01.06.13	VAR	Appd	R.C.A	-sd-	10.06.13	73					74								
DRN	SS/DK	SIGN	DATE	NO. OF																												
CHD	LS/RR	-sd-	01.06.13	VAR																												
Appd	R.C.A	-sd-	10.06.13	73																												
				74																												
<table border="1"> <tr> <td>DRN</td> <td>SS/DK</td> <td>SIGN</td> <td>DATE</td> <td>NO. OF</td> </tr> <tr> <td>CHD</td> <td>LS/RR</td> <td>-sd-</td> <td>01.06.13</td> <td>VAR</td> </tr> <tr> <td>Appd</td> <td>R.C.A</td> <td>-sd-</td> <td>10.06.13</td> <td>73</td> </tr> <tr> <td></td> <td></td> <td></td> <td></td> <td>74</td> </tr> </table>					DRN	SS/DK	SIGN	DATE	NO. OF	CHD	LS/RR	-sd-	01.06.13	VAR	Appd	R.C.A	-sd-	10.06.13	73					74								
DRN	SS/DK	SIGN	DATE	NO. OF																												
CHD	LS/RR	-sd-	01.06.13	VAR																												
Appd	R.C.A	-sd-	10.06.13	73																												
				74																												
<table border="1"> <tr> <td>DRN</td> <td>SS/DK</td> <td>SIGN</td> <td>DATE</td> <td>NO. OF</td> </tr> <tr> <td>CHD</td> <td>LS/RR</td> <td>-sd-</td> <td>01.06.13</td> <td>VAR</td> </tr> <tr> <td>Appd</td> <td>R.C.A</td> <td>-sd-</td> <td>10.06.13</td> <td>73</td> </tr> <tr> <td></td> <td></td> <td></td> <td></td> <td>74</td> </tr> </table>					DRN	SS/DK	SIGN	DATE	NO. OF	CHD	LS/RR	-sd-	01.06.13	VAR	Appd	R.C.A	-sd-	10.06.13	73					74								
DRN	SS/DK	SIGN	DATE	NO. OF																												
CHD	LS/RR	-sd-	01.06.13	VAR																												
Appd	R.C.A	-sd-	10.06.13	73																												
				74																												
<table border="1"> <tr> <td>DRN</td> <td>SS/DK</td> <td>SIGN</td> <td>DATE</td> <td>NO. OF</td> </tr> <tr> <td>CHD</td> <td>LS/RR</td> <td>-sd-</td> <td>01.06.13</td> <td>VAR</td> </tr> <tr> <td>Appd</td> <td>R.C.A</td> <td>-sd-</td> <td>10.06.13</td> <td>73</td> </tr> <tr> <td></td> <td></td> <td></td> <td></td> <td>74</td> </tr> </table>					DRN	SS/DK	SIGN	DATE	NO. OF	CHD	LS/RR	-sd-	01.06.13	VAR	Appd	R.C.A	-sd-	10.06.13	73					74								
DRN	SS/DK	SIGN	DATE	NO. OF																												
CHD	LS/RR	-sd-	01.06.13	VAR																												
Appd	R.C.A	-sd-	10.06.13	73																												
				74																												
<table border="1"> <tr> <td>DRN</td> <td>SS/DK</td> <td>SIGN</td> <td>DATE</td> <td>NO. OF</td> </tr> <tr> <td>CHD</td> <td>LS/RR</td> <td>-sd-</td> <td>01.06.13</td> <td>VAR</td> </tr> <tr> <td>Appd</td> <td>R.C.A</td> <td>-sd-</td> <td>10.06.13</td> <td>73</td> </tr> <tr> <td></td> <td></td> <td></td> <td></td> <td>74</td> </tr> </table>					DRN	SS/DK	SIGN	DATE	NO. OF	CHD	LS/RR	-sd-	01.06.13	VAR	Appd	R.C.A	-sd-	10.06.13	73					74								
DRN	SS/DK	SIGN	DATE	NO. OF																												
CHD	LS/RR	-sd-	01.06.13	VAR																												
Appd	R.C.A	-sd-	10.06.13	73																												
				74																												
<table border="1"> <tr> <td>DRN</td> <td>SS/DK</td> <td>SIGN</td> <td>DATE</td> <td>NO. OF</td> </tr> <tr> <td>CHD</td> <td>LS/RR</td> <td>-sd-</td> <td>01.06.13</td> <td>VAR</td> </tr> <tr> <td>Appd</td> <td>R.C.A</td> <td>-sd-</td> <td>10.06.13</td> <td>73</td> </tr> <tr> <td></td> <td></td> <td></td> <td></td> <td>74</td> </tr> </table>					DRN	SS/DK	SIGN	DATE	NO. OF	CHD	LS/RR	-sd-	01.06.13	VAR	Appd	R.C.A	-sd-	10.06.13	73					74								
DRN	SS/DK	SIGN	DATE	NO. OF																												
CHD	LS/RR	-sd-	01.06.13	VAR																												
Appd	R.C.A	-sd-	10.06.13	73																												
				74																												
<table border="1"> <tr> <td>DRN</td> <td>SS/DK</td> <td>SIGN</td> <td>DATE</td> <td>NO. OF</td> </tr> <tr> <td>CHD</td> <td>LS/RR</td> <td>-sd-</td> <td>01.06.13</td> <td>VAR</td> </tr> <tr> <td>Appd</td> <td>R.C.A</td> <td>-sd-</td> <td>10.06.13</td> <td>73</td> </tr> <tr> <td></td> <td></td> <td></td> <td></td> <td>74</td> </tr> </table>					DRN	SS/DK	SIGN	DATE	NO. OF	CHD	LS/RR	-sd-	01.06.13	VAR	Appd	R.C.A	-sd-	10.06.13	73					74								
DRN	SS/DK	SIGN	DATE	NO. OF																												
CHD	LS/RR	-sd-	01.06.13	VAR																												
Appd	R.C.A	-sd-	10.06.13	73																												
				74																												
<table border="1"> <tr> <td>DRN</td> <td>SS/DK</td> <td>SIGN</td> <td>DATE</td> <td>NO. OF</td> </tr> <tr> <td>CHD</td> <td>LS/RR</td> <td>-sd-</td> <td>01.06.13</td> <td>VAR</td> </tr> <tr> <td>Appd</td> <td>R.C.A</td> <td>-sd-</td> <td>10.06.13</td> <td>73</td> </tr> <tr> <td></td> <td></td> <td></td> <td></td> <td>74</td> </tr> </table>					DRN	SS/DK	SIGN	DATE	NO. OF	CHD	LS/RR	-sd-	01.06.13	VAR	Appd	R.C.A	-sd-	10.06.13	73					74								
DRN	SS/DK	SIGN	DATE	NO. OF																												
CHD	LS/RR	-sd-	01.06.13	VAR																												
Appd	R.C.A	-sd-	10.06.13	73																												
				74																												
<table border="1"> <tr> <td>DRN</td> <td>SS/DK</td> <td>SIGN</td> <td>DATE</td> <td>NO. OF</td> </tr> <tr> <td>CHD</td> <td>LS/RR</td> <td>-sd-</td> <td>01.06.13</td> <td>VAR</td> </tr> <tr> <td>Appd</td> <td>R.C.A</td> <td>-sd-</td> <td>10.06.13</td> <td>73</td> </tr> <tr> <td></td> <td></td> <td></td> <td></td> <td>74</td> </tr> </table>					DRN	SS/DK	SIGN	DATE	NO. OF	CHD	LS/RR	-sd-	01.06.13	VAR	Appd	R.C.A	-sd-	10.06.13	73					74								
DRN	SS/DK	SIGN	DATE	NO. OF																												
CHD	LS/RR	-sd-	01.06.13	VAR																												
Appd	R.C.A	-sd-	10.06.13	73																												
				74																												
<table border="1"> <tr> <td>DRN</td> <td>SS/DK</td> <td>SIGN</td> <td>DATE</td> <td>NO. OF</td> </tr> <tr> <td>CHD</td> <td>LS/RR</td> <td>-sd-</td> <td>01.06.13</td> <td>VAR</td> </tr> <tr> <td>Appd</td> <td>R.C.A</td> <td>-sd-</td> <td>10.06.13</td> <td>73</td> </tr> <tr> <td></td> <td></td> <td></td> <td></td> <td>74</td> </tr> </table>					DRN	SS/DK	SIGN	DATE	NO. OF	CHD	LS/RR	-sd-	01.06.13	VAR	Appd	R.C.A	-sd-	10.06.13	73					74								
DRN	SS/DK	SIGN	DATE	NO. OF																												
CHD	LS/RR	-sd-	01.06.13	VAR																												
Appd	R.C.A	-sd-	10.06.13	73																												
				74																												
<table border="1"> <tr> <td>DRN</td> <td>SS/DK</td> <td>SIGN</td> <td>DATE</td> <td>NO. OF</td> </tr> <tr> <td>CHD</td> <td>LS/RR</td> <td>-sd-</td> <td>01.06.13</td> <td>VAR</td> </tr> <tr> <td>Appd</td> <td>R.C.A</td> <td>-sd-</td> <td>10.06.13</td> <td>73</td> </tr> <tr> <td></td> <td></td> <td></td> <td></td> <td>74</td> </tr> </table>					DRN	SS/DK	SIGN	DATE	NO. OF	CHD	LS/RR	-sd-	01.06.13	VAR	Appd	R.C.A	-sd-	10.06.13	73					74								
DRN	SS/DK	SIGN	DATE	NO. OF																												
CHD	LS/RR	-sd-	01.06.13	VAR																												
Appd	R.C.A	-sd-	10.06.13	73																												
				74																												
<table border="1"> <tr> <td>DRN</td> <td>SS/DK</td> <td>SIGN</td> <td>DATE</td> <td>NO. OF</td> </tr> <tr> <td>CHD</td> <td>LS/RR</td> <td>-sd-</td> <td>01.06.13</td> <td>VAR</td> </tr> <tr> <td>Appd</td> <td>R.C.A</td> <td>-sd-</td> <td>10.06.13</td> <td>73</td> </tr> <tr> <td></td> <td></td> <td></td> <td></td> <td>74</td> </tr> </table>					DRN	SS/DK	SIGN	DATE	NO. OF	CHD	LS/RR	-sd-	01.06.13	VAR	Appd	R.C.A	-sd-	10.06.13	73					74								
DRN	SS/DK	SIGN	DATE	NO. OF																												
CHD	LS/RR	-sd-	01.06.13	VAR																												
Appd	R.C.A	-sd-	10.06.13	73																												
				74																												
<table border="1"> <tr> <td>DRN</td> <td>SS/DK</td> <td>SIGN</td> <td>DATE</td> <td>NO. OF</td> </tr> <tr> <td>CHD</td> <td>LS/RR</td> <td>-sd-</td> <td>01.06.13</td> <td>VAR</td> </tr> <tr> <td>Appd</td> <td>R.C.A</td> <td>-sd-</td> <td>10.06.13</td> <td>73</td> </tr> <tr> <td></td> <td></td> <td></td> <td></td> <td>74</td> </tr> </table>					DRN	SS/DK	SIGN	DATE	NO. OF	CHD	LS/RR	-sd-	01.06.13	VAR	Appd	R.C.A	-sd-	10.06.13	73					74								
DRN	SS/DK	SIGN	DATE	NO. OF																												
CHD	LS/RR	-sd-	01.06.13	VAR																												
Appd	R.C.A	-sd-	10.06.13	73																												
				74																												
<table border="1"> <tr> <td>DRN</td> <td>SS/DK</td> <td>SIGN</td> <td>DATE</td> <td>NO. OF</td> </tr> <tr> <td>CHD</td> <td>LS/RR</td> <td>-sd-</td> <td>01.06.13</td> <td>VAR</td> </tr> <tr> <td>Appd</td> <td>R.C.A</td> <td>-sd-</td> <td>10.06.13</td> <td>73</td> </tr> <tr> <td></td> <td></td> <td></td> <td></td> <td>74</td> </tr> </table>					DRN	SS/DK	SIGN	DATE	NO. OF	CHD	LS/RR	-sd-	01.06.13	VAR	Appd	R.C.A	-sd-	10.06.13	73					74								
DRN	SS/DK	SIGN	DATE	NO. OF																												
CHD	LS/RR	-sd-	01.06.13	VAR																												
Appd	R.C.A	-sd-	10.06.13	73																												
				74																												
<table border="1"> <tr> <td>DRN</td> <td>SS/DK</td> <td>SIGN</td> <td>DATE</td> <td>NO. OF</td> </tr> <tr> <td>CHD</td> <td>LS/RR</td> <td>-sd-</td> <td>01.06.13</td> <td>VAR</td> </tr> <tr> <td>Appd</td> <td>R.C.A</td> <td>-sd-</td> <td>10.06.13</td> <td>73</td> </tr> <tr> <td></td> <td></td> <td></td> <td></td> <td>74</td> </tr> </table>					DRN	SS/DK	SIGN	DATE	NO. OF	CHD	LS/RR	-sd-	01.06.13	VAR	Appd	R.C.A	-sd-	10.06.13	73					74								
DRN	SS/DK	SIGN	DATE	NO. OF																												
CHD	LS/RR	-sd-	01.06.13	VAR																												
Appd	R.C.A	-sd-	10.06.13	73																												
				74																												
<table border="1"> <tr> <td>DRN</td> <td>SS/DK</td> <td>SIGN</td> <td>DATE</td> <td>NO. OF</td> </tr> <tr> <td>CHD</td> <td>LS/RR</td> <td>-sd-</td> <td>01.06.13</td> <td>VAR</td> </tr> <tr> <td>Appd</td> <td>R.C.A</td> <td>-sd-</td> <td>10.06.13</td> <td>73</td> </tr> <tr> <td></td> <td></td> <td></td> <td></td> <td>74</td> </tr> </table>					DRN	SS/DK	SIGN	DATE	NO. OF	CHD	LS/RR	-sd-	01.06.13	VAR	Appd	R.C.A	-sd-	10.06.13	73					74								
DRN	SS/DK	SIGN	DATE	NO. OF																												
CHD	LS/RR	-sd-	01.06.13	VAR																												
Appd	R.C.A	-sd-	10.06.13	73																												
				74																												
<table border="1"> <tr> <td>DRN</td> <td>SS/DK</td> <td>SIGN</td> <td>DATE</td> <td>NO. OF</td> </tr> <tr> <td>CHD</td> <td>LS/RR</td> <td>-sd-</td> <td>01.06.13</td> <td>VAR</td> </tr> <tr> <td>Appd</td> <td>R.C.A</td> <td>-sd-</td> <td>10.06.13</td> <td>73</td> </tr> <tr> <td></td> <td></td> <td></td> <td></td> <td>74</td> </tr> </table>					DRN	SS/DK	SIGN	DATE	NO. OF	CHD	LS/RR	-sd-	01.06.13	VAR	Appd	R.C.A	-sd-	10.06.13	73					74								
DRN	SS/DK	SIGN	DATE	NO. OF																												
CHD	LS/RR	-sd-	01.06.13	VAR																												
Appd	R.C.A	-sd-	10.06.13	73																												
				74																												
<table border="1"> <tr> <td>DRN</td> <td>SS/DK</td> <td>SIGN</td> <td>DATE</td> <td>NO. OF</td> </tr> <tr> <td>CHD</td> <td>LS/RR</td> <td>-sd-</td> <td>01.06.13</td> <td>VAR</td> </tr> <tr> <td>Appd</td> <td>R.C.A</td> <td>-sd-</td> <td>10.06.13</td> <td>73</td> </tr> <tr> <td></td> <td></td> <td></td> <td></td> <td>74</td> </tr> </table>					DRN	SS/DK	SIGN	DATE	NO. OF	CHD	LS/RR	-sd-	01.06.13	VAR	Appd	R.C.A	-sd-	10.06.13	73					74								
DRN	SS/DK	SIGN	DATE	NO. OF																												
CHD	LS/RR	-sd-	01.06.13	VAR																												
Appd	R.C.A	-sd-	10.06.13	73																												
				74																												
<table border="1"> <tr> <td>DRN</td> <td>SS/DK</td> <td>SIGN</td> <td>DATE</td> <td>NO. OF</td> </tr> <tr> <td>CHD</td> <td>LS/RR</td> <td>-sd-</td> <td>01.06.13</td> <td>VAR</td> </tr> <tr> <td>Appd</td> <td>R.C.A</td> <td>-sd-</td> <td>10.06.13</td> <td>73</td> </tr> <tr> <td></td> <td></td> <td></td> <td></td> <td>74</td> </tr> </table>					DRN	SS/DK	SIGN	DATE	NO. OF	CHD	LS/RR	-sd-	01.06.13	VAR	Appd	R.C.A	-sd-	10.06.13	73					74								
DRN	SS/DK	SIGN	DATE	NO. OF																												
CHD	LS/RR	-sd-	01.06.13	VAR																												
Appd	R.C.A	-sd-	10.06.13	73																												
				74																												
<table border="1"> <tr> <td>DRN</td> <td>SS/DK</td> <td>SIGN</td> <td>DATE</td> <td>NO. OF</td> </tr> <tr> <td>CHD</td> <td>LS/RR</td> <td>-sd-</td> <td>01.06.13</td> <td>VAR</td> </tr> <tr> <td>Appd</td> <td>R.C.A</td> <td>-sd-</td> <td>10.06.13</td> <td>73</td> </tr> <tr> <td></td> <td></td> <td></td> <td></td> <td>74</td> </tr> </table>					DRN	SS/DK	SIGN	DATE	NO. OF	CHD	LS/RR	-sd-	01.06.13	VAR	Appd	R.C.A	-sd-	10.06.13	73					74								
DRN	SS/DK	SIGN	DATE	NO. OF																												
CHD	LS/RR	-sd-	01.06.13	VAR																												
Appd	R.C.A	-sd-	10.06.13	73																												
				74																												
<table border="1"> <tr> <td>DRN</td> <td>SS/DK</td> <td>SIGN</td> <td>DATE</td> <td>NO. OF</td> </tr> <tr> <td>CHD</td> <td>LS/RR</td> <td>-sd-</td> <td>01.06.13</td> <td>VAR</td> </tr> <tr> <td>Appd</td> <td>R.C.A</td> <td>-sd-</td> <td>10.06.13</td> <td>73</td> </tr> <tr> <td></td> <td></td> <td></td> <td></td> <td>74</td> </tr> </table>					DRN	SS/DK	SIGN	DATE	NO. OF	CHD	LS/RR	-sd-	01.06.13	VAR	Appd	R.C.A	-sd-	10.06.13	73					74								
DRN	SS/DK	SIGN	DATE	NO. OF																												
CHD	LS/RR	-sd-	01.06.13	VAR																												
Appd	R.C.A	-sd-	10.06.13	73																												
				74																												
<table border="1"> <tr> <td>DRN</td> <td>SS/DK</td> <td>SIGN</td> <td>DATE</td> <td>NO. OF</td> </tr> <tr> <td>CHD</td> <td>LS/RR</td> <td>-sd-</td> <td>01.06.13</td> <td>VAR</td> </tr> <tr> <td>Appd</td> <td>R.C.A</td> <td>-sd-</td> <td>10.06.13</td> <td>73</td> </tr> <tr> <td></td> <td></td> <td></td> <td></td> <td>74</td> </tr> </table>					DRN	SS/DK	SIGN	DATE	NO. OF	CHD	LS/RR	-sd-	01.06.13	VAR	Appd	R.C.A	-sd-	10.06.13	73					74								
DRN	SS/DK	SIGN	DATE	NO. OF																												
CHD	LS/RR	-sd-	01.06.13	VAR																												
Appd	R.C.A	-sd-	10.06.13	73																												
				74																												
<table border="1"> <tr> <td>DRN</td> <td>SS/DK</td> <td>SIGN</td> <td>DATE</td> <td>NO. OF</td> </tr> <tr> <td>CHD</td> <td>LS/RR</td> <td>-sd-</td> <td>01.06.13</td> <td>VAR</td> </tr> <tr> <td>Appd</td> <td>R.C.A</td> <td>-sd-</td> <td>10.06.13</td> <td>73</td> </tr> <tr> <td></td> <td></td> <td></td> <td></td> <td>74</td> </tr> </table>					DRN	SS/DK	SIGN	DATE	NO. OF	CHD	LS/RR	-sd-	01.06.13	VAR	Appd	R.C.A	-sd-	10.06.13	73					74								
DRN	SS/DK	SIGN	DATE	NO. OF																												
CHD	LS/RR	-sd-	01.06.13	VAR																												
Appd	R.C.A	-sd-	10.06.13	73																												
				74																												
<table border="1"> <tr> <td>DRN</td> <td>SS/DK</td> <td>SIGN</td> <td>DATE</td> <td>NO. OF</td> </tr> <tr> <td>CHD</td> <td>LS/RR</td> <td>-sd-</td> <td>01.06.13</td> <td>VAR</td> </tr> <tr> <td>Appd</td> <td>R.C.A</td> <td>-sd-</td> <td>10.06.13</td> <td>73</td> </tr> <tr> <td></td> <td></td> <td></td> <td></td> <td>74</td> </tr> </table>					DRN	SS/DK	SIGN	DATE	NO. OF	CHD	LS/RR	-sd-	01.06.13	VAR	Appd	R.C.A	-sd-	10.06.13	73					74								
DRN	SS/DK	SIGN	DATE	NO. OF																												
CHD	LS/RR	-sd-	01.06.13	VAR																												
Appd	R.C.A	-sd-	10.06.13	73																												
				74																												
<table border="1"> <tr> <td>DRN</td> <td>SS/DK</td> <td>SIGN</td> <td>DATE</td> <td>NO. OF</td> </tr> <tr> <td>CHD</td> <td>LS/RR</td> <td>-sd-</td> <td>01.06.13</td> <td>VAR</td> </tr> <tr> <td>Appd</td> <td>R.C.A</td> <td>-sd-</td> <td>10.06.13</td> <td>73</td> </tr> <tr> <td></td> <td></td> <td></td> <td></td> <td>74</td> </tr> </table>					DRN	SS/DK	SIGN	DATE	NO. OF	CHD	LS/RR	-sd-	01.06.13	VAR	Appd	R.C.A	-sd-	10.06.13	73					74								
DRN	SS/DK	SIGN	DATE	NO. OF																												
CHD	LS/RR	-sd-	01.06.13	VAR																												
Appd	R.C.A	-sd-	10.06.13	73																												
				74																												
<table border="1"> <tr> <td>DRN</td> <td>SS/DK</td> <td>SIGN</td> <td>DATE</td> <td>NO. OF</td> </tr> <tr> <td>CHD</td> <td>LS/RR</td> <td>-sd-</td> <td>01.06.13</td> <td>VAR</td> </tr> </table>					DRN	SS/DK	SIGN	DATE	NO. OF	CHD	LS/RR	-sd-	01.06.13	VAR																		
DRN	SS/DK	SIGN	DATE	NO. OF																												
CHD	LS/RR	-sd-	01.06.13	VAR																												

SIGN & DATE



PRODUCT STANDARD
STEAM TURBINE

ST 22007

PAGE 1 OF 7

SUPERSEDES
INVENTORY No.Based on BHEL experience**COPYRIGHT AND CONFIDENTIAL**

The information on this document is the property of Bharat Heavy Electrical Limited. It must not be used directly or indirectly in any way detrimental to the interest of the company.

**TECHNICAL DELIVERY
SPECIFICATIONS
FOR
FIRE RESISTANT FLUID**

SIGN & DATE	ISE & CPL	NAME	DATE & SIGN	SUPERVISED	NAME	SIGN & DATE
P-5573 25/6/01	ISE & CPL	VIRENDRA KUMAR	<i>Virendra Kumar</i> 23.10.04	DRAWN	RPS / UKH	<i>RPS</i> 19.6.01
	TSX	KISHAN LAL	<i>KL</i> 20/6/01	WORKED	RCA	<i>RCA</i> 19.6.01
	QAX	S.SHAUHAN	<i>S.Shaohan</i>	CHECKED	RCA	<i>RCA</i> 19.6.01
	AGREED DEPTT.	NAME	DATE & SIGN	SUPERVISED	BSS	<i>RPS</i> 19.6.01
				APPROVED	<i>K.M. Singhal</i> 20/6/2001	8.20
					ADDL. GENERAL MANAGER	Gr.No
	REV. No. 02			F REPAIRED:	ISSUED: DATE	
	DATE: 14-7-12			S.T.E-TG	S.T.E-TG 20-6-2001	

SIGN & DATE



PRODUCT STANDARD

ST22007

STEAM TURBINE

Page 2 of 7

SUPERSEDES
INVENTORY No.

1.0 SCOPE:

This specification is applicable for fire resistant fluids, hereafter referred to as FRF, used as a pressure transmitting medium in the turbine control and governing system, electro-hydraulic actuators (compact drives and electro-hydraulic drives) with integrated hydraulic supply (nominal pressure 160 bar). The specification is based on TLV 9012 AUSF 01; 9012 02.

2.0 GENERAL REQUIREMENTS:

2.1 TYPE OF FIRE RESISTANT FLUID:

The FRF shall be Triarylphosphate esters type free from water content. The FRF is designated as HFD according to DIN 51502.

2.2 CHEMICAL COMPOSITION:

The FRF shall be 100% natural Trixylenyl phosphate (TXP), a reaction product of phosphorus oxychloride and xylol. This product has the following chemical formula.

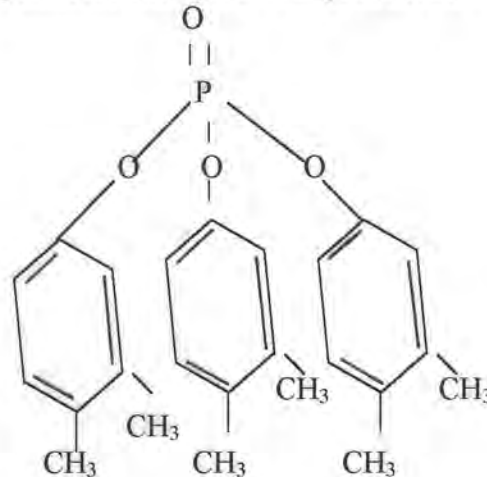

CAS NUMBER 25155 - 23 -1

The final product must be free of neurotoxic quantities of ortho-cresol-compounds. In order to improve certain properties e.g. corrosion protection, oxidation stability, additives may be included provided they have no negative effect on the materials of the FRF-system or its operation.

2.3 CORROSION PROTECTION:

- The FRF shall not cause corrosion to the following materials:
Steel, Copper, Copper Alloys, Zinc, Tin, Aluminum.
- The FRF must be capable of providing sufficient corrosion protection to the materials used in the FRF-system.
- The FRF will be continuously regenerated with a regeneration agent.
- The FRF must not cause any erosion or corrosion on the edges of the control elements.

COPYRIGHT AND CONFIDENTIAL
The information on this document is the property of Bharat Heavy Electrical Limited.
It must not be used directly or indirectly in any way detrimental to the interest of the company

SIGN & Date

17/11/04

INVENTORY
No.

P-5573

REV NO.02

WORKED BY:

RCA

CHECKED BY:

PCB

[Handwritten signature]
[Handwritten signature]

SIGN &
DATE



PRODUCT STANDARD

STEAM TURBINE

ST22007

Page 3 of 7

SUPERSEDES
INVENTORY No.

2.4 VISCOSITY GROUP:

The FRF shall be of viscosity group ISO VG 46.

2.5 LIFE TIME:

Under the mentioned conditions and with regular regeneration, the FRF must provide a minimum life time of 25000 operating hours without any significant change in its properties. The maximum permissible limit of alteration in parameters during its working life are indicated under clause 2.13.

2.6 SHEAR STABILITY:

The FRF must be shear-stable . It should not contain Viscosity Index (VI) improver.

2.7 FIRE RESISTANCE:

The FRF leaking from the system must not ignite or burn in contact with hot surface (upto 550°C).

2.8 THERMAL STABILITY:

The FRF must be capable for withstanding a continuous temperatures of 75°C without physical or chemical degradation.

2.9 COMPATIBILITY WITH ANOTHER BRAND OF FRF:

The FRF must be miscible with traces (Max. 3% by Volume) of TXP of another brand. There should be no deterioration of the FRF in the presence of such trace quantities.

2.10 COMPATIBILITY WITH PACKING MATERIAL:

The FRF must be compatible with the following packing materials used in the system:

Fluorocarbon rubber (FKM), butyl rubber (IIR), Polytetrafluoroethylene (PTFE), Polyethelene (PE), Polyamide (PA), Di-isocyanate adhesive, Polyurethane / Polyester.

The FRF should not have a negative influence on its air-separation capability in the presence of above packing materials.

2.11 PHYSIOLOGICAL CONSIDERATIONS:

The FRF must not cause a safety or health hazard to the persons working with it provided that normal good industrial hygiene practices are followed.

COPYRIGHT AND CONFIDENTIAL
The information on this documents is the property of Bharat Heavy Electrical Limited. It must not be used directly or indirectly in any way detrimental to the interest of the company

SIGN & Date

12/11/04

INVENTORY
No.

P-5573

REV NO.02

WORKED BY:

RCA

CHECKED BY:

PCB

PRODUCT STANDARD

STEAM TURBINE

ST22007

Page 4 of 7

SIGN &
DATE



SUPERSEDES
INVENTORY No.

2.12 PHYSICAL AND CHEMICAL PROPERTIES:

PROPERTY	NUMERICAL VALUE	UNIT	TEST METHOD	
			DIN / ISO	ASTM
Kinematic Viscosity at 40 °C (ISO VG 46)	41.4 - 50.6	mm ² /s	DIN 51 562-1	D 445
Air release at 50 °C	≤ 3	minutes	DIN 51 381	D 3427
Neutralisation number	≤ 0.1	mg KOH/g	DIN 51 558-1	D 974
Water content	≤ 1000	mg/kg	DIN 51 777-3	
Foaming at 25 °C : Tendency	≤ 100 ≤ 450	ml sec		D 892 (Seq.1)
Stability				
Water separability	≤ 300	sec	DIN 51 589-1	
Demulsification	≤ 20	minutes	DIN 51 599	D 1401
Density at 15 °C	≤ 1250	kg/m ³	DIN 51 757	D 1298
Flash point (Cleveland open cup)	> 235	°C	DIN/ISO 2592	D 92
Ignition temperature	> 550	°C	DIN 51 794	
Wick flame persistence time	≤ 5	sec	DIN/ISO 14935	
Pour point	≤ -18	°C	DIN/ISO 3016	D 97
Particle distribution *	≤ 15/12	Code	ISO 4406	
Chlorine content	≤ 50	mg/kg	DIN 51 577-3	
Oxidation stability	≤ 2.0	mg KOH/g	DIN 51 373	
Hydrolytic stability Change of neutralisation number	≤ 2.0	mg KOH/g	DIN 51 348	
Electrical resistivity	> 50	MΩm	IEC 247	

* The cleanliness level refers to the oil condition on delivery. The required system cleanliness is dependent upon the system design. Suitable measures (e.g. filtration, separation) have to be taken to achieve this cleanliness level.

NOTE: THE INFRARED (IR) SPECTRA OF FRF SHALL MATCH WITH THE IR SPECTRA GIVEN AT PAGE-7.

SIGN & Date

25/6/01

INVENTORY No.

P-5573

REV. NO: 02

WORKED BY:

RCA

19.6.2001

CHECKED BY:

BSS

19.6.2001

SIGN & DATE



PRODUCT STANDARD

ST22007

STEAM TURBINE

Page 5 of 7

SUPERSEDES INVENTORY No.

2.13 LIMIT VALUES:

The following limit values should not be exceeded during the required life time:

a) Kinematic viscosity:

Maximum alteration $\pm 5\%$ referring to the condition on delivery

b) Neutralisation number:

Maximum increase 0.20 mg KOH/g referring to the condition on delivery

c) Air release:

Max. 12 minutes

d) Foaming at 25 degrees centigrade:

Tendency: max 200 ml

Stability: max 450 s

3.0 INFORMATION REQUIRED TO BE FURNISHED ALONG WITH THE OFFER:

3.1 The bidder shall furnish the complete technical information of the offered product which may also include a) product description, b) chemical name and structure, c) Infrared spectra of the fluid, d) properties, e) disposal procedure, f) minimum working life, g) storage, handling and safety instructions, h) shipping method to be adopted at the time of delivery.

3.2 The bidder shall furnish confirmation regarding compliance of all the requirements as specified in this purchase specification along with the offer. In case of any deviation, the same shall be clearly informed by the bidder at the time of offer.

3.3 The bidder shall submit list of their customers utilising the fluid for application defined as per clause 1.0.

3.4 The offered grade of FRF should be of approved grade by M/S Siemens, Germany.

3.5 The approval of FRF does not make the supplier free from their responsibility for the quality of their product. The purchaser must be informed without fail in case of any alteration in their product or manufacturing process. In such cases a new approval by BHEL will become necessary.

4.0 DOCUMENTS TO BE FURNISHED AFTER PLACEMENT OF ORDER:

4.1 The supplier shall inform about the test results from internationally accredited lab giving the batch no., parameter, actual value obtained, test method of the batches proposed to be delivered and take approval from the purchaser before its despatch. As a minimum the following parameters have to be checked as per clause 2.12. Viscosity; air release; neutralisation number; water content; foaming tendency, water separability or demulsification.

4.2 Certificate of compliance to the specification, and also certificate of compliance to the properties as per clause 2.12 as well as chemical structure formula as per clause 2.2 shall be furnished.

4.3 The supplier shall furnish a copy of Infrared Spectra of the batches proposed to be delivered.

COPYRIGHT AND CONFIDENTIAL

The information on this document is the property of Bharat Heavy Electricals Limited. It must not be used directly or indirectly in any way detrimental to the interest of the company

SIGN & Date

INVENTORY No.

17/11/04
P-5573

REV NO.02

WORKED BY:

RCA

CHECKED BY:

PCB

PRODUCT STANDARD

ST22007

STEAM TURBINE

Page 6 of 7

SIGN &
DATE



SUPERSEDES
INVENTORY No.

5.0 TEST CERTIFICATES / DOCUMENTS TO BE SUBMITTED WITH SUPPLIES:

10 nos. of hard copies and 3 nos. of soft copies of the following documents shall be furnished by the supplier along with each supply. The customer's and project's name shall be indicated on each document as prescribed by the purchaser.

- a) The test certificates as per clause 4.1 and the compliance certificate to the effect that the product supplied is natural trixylenyl phosphate ester fluid and properties as per clause 2.12.
- b) The supplier shall furnish Material Safety Data Sheet (MSDS) covering all information relating to human safety and environmental impacts of the hazardous materials particularly during its transportation, storage, handling and disposal.
- c) Marking of containers: The FRF must be delivered in cleaned containers. The following information are to be clearly indicated on each container:
 - (i) Product name, manufacturer / supplier, filling date, batch number, Net weight, Gross weight, Expiry date.
 - (ii) Corresponding symbol and minimum worded cautionary notice for flammable/ corrosive / toxic / harmful / irritant and oxidising etc. as applicable.

6.0 SPECIAL AGREEMENTS:

Special agreements concerning variations from the requirements of this specification need authorisation by the purchaser. These must be settled through letter.

7.0 FILLING OF THE SYSTEM BY THE SUPPLIER:

- 7.1 Before filling the system a 2 litre sample shall be taken and sent to the laboratory for analysis. In the case of more than one batch, the supplier will blend a 2 litre sample from those batches. The proportions of the blend should reflect the final mixture that will result from filling the various batches into the hydraulic control system. Permission for filling will be given by the owner / purchaser after review of test results of the sample.
- 7.2 Filling of the system shall be made by the supplier at his own risk and expense.
- 7.3 The filling is to be made through a filter unit having a mesh of 5 micron. The tools used for filling the system must not affect the quality of FRF.

8.0 SAFETY MEASURES:

The safety precautions which are to be observed by the personnel dealing with FRF, shall be clearly demonstrated / informed to the Purchaser by the FRF supplier in the form of specific safety instructions.

9.0 CROSS REFERRED STANDARDS:

DIN 51 502; DIN 51 562-1; DIN 51 381; DIN 51 558-1; DIN 51 777-3; DIN 51 589-1; DIN 51 599; DIN 51 757; DIN ISO 2592; DIN 51 794; DIN ISO 14935; DIN ISO 3016; ISO 4406; DIN 51 577-3; DIN 51 373; DIN 51 348; IEC 247; ASTM D 445; ASTM D 3427; ASTM D 974; ASTM D 1744; ASTM D 892 (Seq.1); ASTM D 1401; ASTM D 1298; ASTM D 92; ASTM D 97.

COPYRIGHT AND CONFIDENTIAL
The information on this documents is the property of Bharat Heavy Electricals Limited.
It must not be used directly or indirectly in any way detrimental to the interest of the company.

SIGN & Date

17/11/04

INVENTORY No.

R-5573

REV NO. 02

WORKED BY:

RCA

CHECKED BY:

PCB

[Handwritten signatures]

SIGN &
DATE



PRODUCT STANDARD

STEAM TURBINE

ST22007

Page 7 of 7

SUPERSEDES
INVENTORY No.

COPYRIGHT AND CONFIDENTIAL

The information on this documents is the property of Bharat Heavy Electrical Limited.
It must not be used directly or indirectly in any way detrimental to the interest of the company

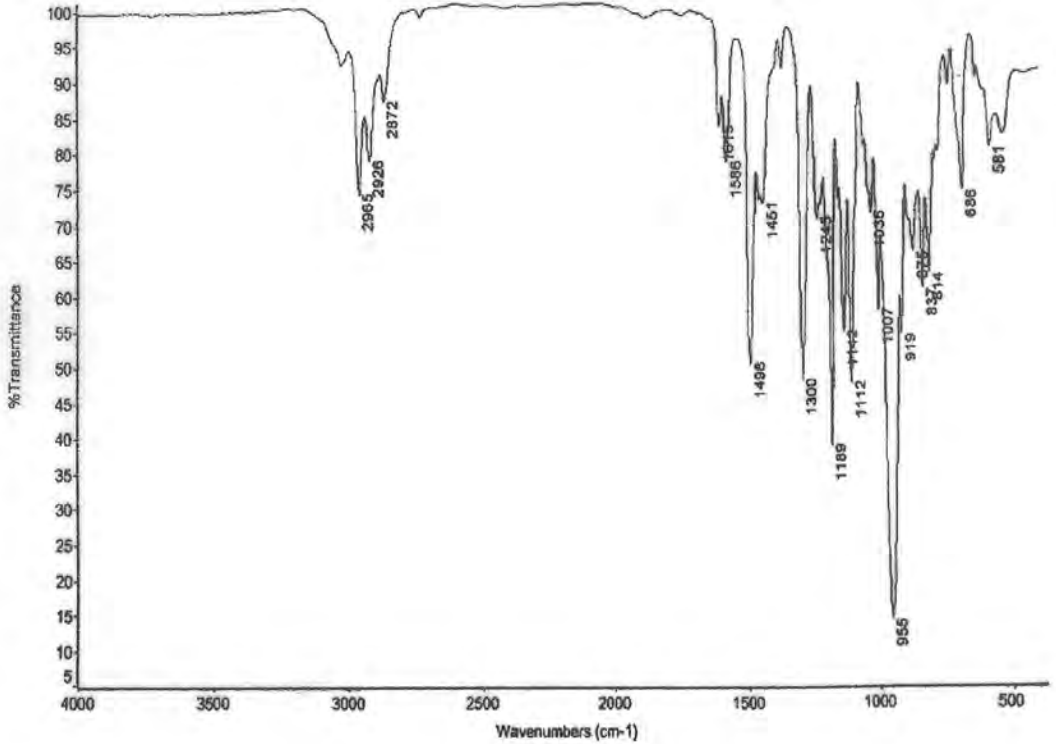

Infrared spectra of FRF (Trixylenyl phosphate)

SIGN & Date

INVENTORY
No.

REV. : 02

WORKED BY:

VIKAS

Vikas
14/7/12

CHECKED BY:

RCA/VK

14/7/12 / Kiran
Kumar

MANUFACTURER'S NAME AND ADDRESS		STANDARD QUALITY PLAN				TO BE FILLED BY BHEL				TO BE FILLED BY BHEL				
VENDOR'S NAME		LP BYPASS SYSTEM		QP NO.	QA/BI/QP/114	REFERENCE DOCUMENT		ACCEPTANCE NORMS		FORMAT OF RECORDS		AGENCY		REMARKS
BHEL		AS PER PO		DATED	10/09/2014	7		8		9		10		11
SL. NO.	COMPONENT & OPERATIONS	DRG. NO.	AS PER PO	TYPE OF CHECK	QUANTUM OF CHECK	CLASS	REFERENCE DOCUMENT	ACCEPTANCE NORMS	FORMAT OF RECORDS	AGENCY	REMARKS			
1	2	3	4	5	6	7	8	9	10	11				
<p>Page 1 of 11</p>														

LPBYPASS STOP& CONTROL VALVE											
1.0	RAW MATERIAL										
1.1	VALVE BODY	A. CHEMICAL COMPOSITION	MAJOR	CHEMICAL ANALYSIS	PERHEAT	AS PER APPROVED DATASHEET	TC	✓	P	V	
		B. MECHANICAL PROPERTIES	MAJOR	-MECH. TEST	PERHEAT	AS PER APPROVED DATASHEET	TC	✓	P	V	
		C. NDT	MAJOR	UT	100% EXCEPT WELD ENDS) ON WELD ENDS	AS PER APPROVED DATASHEET/DRAWING	TC	✓	P	V	
				RT	100%						
				MPI	100%						
1.2	BONNET	A. CHEMICAL COMPOSITION	MAJOR	CHEMICAL ANALYSIS	PERHEAT	AS PER APPROVED DATASHEET	TC	✓	P	V	
		B. MECHANICAL PROPERTIES	MAJOR	-MECH. TEST	PERHEAT	AS PER APPROVED DATASHEET	TC	✓	P	V	
		C. NDT	MAJOR	UT	100%	AS PER APPROVED DATASHEET	TC	✓	P	V	
				MPI	100%						
1.3	NOZZLES	A. CHEMICAL COMPOSITION	MAJOR	CHEMICAL ANALYSIS	PERHEAT	AS PER APPROVED DATASHEET	TC	✓	P	V	
		B. MECHANICAL PROPERTIES	MAJOR	-MECH. TEST	PERHEAT	AS PER APPROVED DATASHEET	TC	✓	P	V	
		C. NDT	MAJOR	UT/MPI	100%	AS PER APPROVED DATASHEET	TC	✓	P	V	
1.4	TRANSITION PIECES	A. CHEMICAL COMPOSITION	MAJOR	CHEMICAL ANALYSIS	PERHEAT	AS PER APPROVED DATASHEET	TC	✓	P	V	
		B. MECHANICAL PROPERTIES	MAJOR	-MECH. TEST	PERHEAT	AS PER APPROVED DATASHEET	TC	✓	P	V	
		C. NDT	MAJOR	UT/MPI	100%	AS PER APPROVED DATASHEET	TC	✓	P	V	
1.5	SUSPENSION	A. CHEMICAL COMPOSITION	MAJOR	CHEMICAL ANALYSIS	PERHEAT	AS PER APPROVED DATASHEET	TC	✓	P	V	

MANUFACTURER/SUB CONTRACTOR		FOR CUSTOMER USE	
<p>LEGEND:</p> <p>I RECORDS IDENTIFIED WITH 'TICK' SHALL BE ESSENTIALLY INCLUDED BY CONTRACTOR IN QA DOCUMENTATION.</p> <p>M: MANUFACTURER / SUBCONTRACTOR B: BHEL / NOM. INSPECTION AGENCY N: CUSTOMER</p> <p>INDICATE 'P' PERFORM 'W' WITNESS AND 'V' VERIFICATION</p> <p>ALL 'W' INDICATED IN COLUMN 'N' SHALL BE 'CHP' OF CUSTOMER</p>		<p>APPROVED BY</p> <p><i>Sanjeev</i></p> <p>27/01/2015</p> <p>संजीव कुमार भारद्वाज</p> <p>Sanjeev Kumar Bhardwaj</p> <p>अभियन्ता/Engineer</p> <p>गुणता आश्वासन/Quality Assurance</p> <p>बी. एच. ई. एल., हरियाणा/BHEL, Haryana</p>	

25

MANUFACTURER'S NAME AND ADDRESS		STANDARD QUALITY PLAN				TO BE FILLED BY BHEL			TO BE FILLED BY BHEL		
VENDOR'S NAME		LP BYPASS SYSTEM		OP NO.	QA/B/OP/114	FORMAT OF RECORDS		AGENCY		REMARKS	
BHEL		DRG. NO.	AS PER PO	DATED	10/09/2014	M	B	N	10	11	
SL. NO.		CHARACTERISTICS	CLASS	TYPE OF CHECK	QUANTUM OF CHECK	REFERENCE DOCUMENT	ACCEPTANCE NORMS	9	D		
1	2	3	4	5	6	7	8				
COMPONENT & OPERATIONS		REV		Page 2 of 11							
SL. NO.		REV		Page 2 of 11							

SL. NO.	COMPONENT & OPERATIONS	CHARACTERISTICS	CLASS	TYPE OF CHECK	QUANTUM OF CHECK	REFERENCE DOCUMENT	ACCEPTANCE NORMS	9	D	M	B	N	REMARKS
		B. MECHANICAL PROPERTIES	MAJOR	-MECH. TEST	PERHEAT	AS PER APPROVED DATASHEET		TC	✓	P	V		
		C. NDT	MAJOR	UT/MP	100%	AS PER APPROVED DATASHEET		TC	✓	P	V		
1.6	BOLTS/NUTS	A. CHEMICAL COMPOSITION	MAJOR	CHEMICAL ANALYSIS	PERHEAT	AS PER APPROVED DATASHEET		TC	✓	P	V		
		B. MECHANICAL PROPERTIES	MAJOR	-MECH. TEST	PERHEAT	AS PER APPROVED DATASHEET		TC	✓	P	V		
1.7	ACTUATOR	CHEKS ON ACTUATOR	MAJOR	TC REVIEW	PERPIECE	AS PER APPROVED DATASHEET		COC	✓	P	V		
2.0	MANUFACTURING												
2.1	MACHINING PARTS	VISUAL & DIMENSIONAL INSPECTION	MAJOR	VISUAL/ MEASUREMENT	PERPIECE	SHOP TRAVELER			✓	P			
2.2	WELDING & HEAT TREATMENT	WPS	MAJOR	VISUAL TIME/TEMPERATURE	PERPIECE	EN287/ASMEIX			✓	P			
2.3	ASSEMBLY	ASSY. DRWG.	MAJOR	VISUAL	PERPIECE	AS PER APPROVED ASSY. DRAWING			✓	P			
3.0	TESTING & INSPECTION												
3.1	NDE WELDING	RT/UT	MAJOR	RT/UT	PERPIECE	ASME SEC. V/VIII/ HW0980830		TC	✓	P	W		IN CASE OF RT VERIFICATION OF X-RAY FILM
3.2	NDE WELDING	MT/PT	MAJOR	MT/PT	PERPIECE	ASME SEC. V/VIII/ HW0980829		TC	✓	P	W		IN CASE OF RT VERIFICATION OF X-RAY FILM
3.3	HYDROSTATIC PRESSURE TEST	ASSY. DRWG.	MAJOR	HYDRAULIC TEST	ALL VALVES	AS PER APPROVED DATASHEET/ DRAWING		TC	✓	P	W		IBR FORM
3.4	SEAT LEAKAGE	ASSY. DRWG.	MAJOR	LEAKAGE TEST	ALL VALVES	AS PER APPROVED DATASHEET/ DRAWING		TC	✓	P	W		

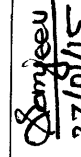
MANUFACTURER/SUB CONTRACTOR		FOR CUSTOMER USE	
		APPROVED BY	
		 27/01/15 Sanjeev Kumar भारद्वाज अभियन्ता/Engineer	
		गुणता आश्वासन/Quality Assurance बी. एच. ई. एल., हरिद्वार/BHEL Haridwar	

LEGEND:
 I RECORDS IDENTIFIED WITH 'TICK' SHALL BE ESSENTIALLY INCLUDED BY CONTRACTOR IN QA DOCUMENTATION.
 M: MANUFACTURER / SUBCONTRACTOR B: BHEL / NOM. INSPECTION AGENCY N: CUSTOMER
 INDICATE 'P' PERFORM 'W' WITNESS AND 'V' VERIFICATION
 ALL 'W' INDICATED IN COLUMN 'N' SHALL BE 'CHP' OF CUSTOMER

29

MANUFACTURER'S NAME AND ADDRESS				STANDARD QUALITY PLAN				TO BE FILLED BY BHEL					
BHEL		VENDOR'S NAME		LP BYPASS SYSTEM		QP NO. DATED		QA/BI/QP/114		10/09/2014		TO BE FILLED BY BHEL	
DRG. NO.		AS PER PO		TYPE OF CHECK		QUANTUM OF CHECK		REFERENCE DOCUMENT		ACCEPTANCE NORMS		FORMAT OF RECORDS	
SPEC.		AS PER PO		5		6		7		8		9 D	
REV		02		CLASS		4		3		3		10 N	
CHARACTERISTICS		3		MEASUREMENT		MAJOR		WELDING+ MAIN DIMENSION		ALL VALVES		AS PERDRAWING	
COMPONENT & OPERATIONS		2		MAJOR		MAJOR		NDE MACHINED		MAJOR		PT	
1		3		MAJOR		MAJOR		FUNCTIONAL TEST AS PERAPPROVED TEST PROCEDURE		MAJOR		PERFORMANCE	
2		4		MAJOR		MAJOR		NOISELEVEL		MAJOR		NOISETEST	
3		5		MAJOR		MAJOR		CV TEST		MAJOR		CV TEST	
4		6		MAJOR		MAJOR		PAINTING,PACKLING AND PRESERVATION		MAJOR		VISUAL	
5		7		MAJOR		MAJOR		PERDESIGN		MAJOR		PERDESIGN	
6		8		MAJOR		MAJOR		ALL VALVES		MAJOR		ALL VALVES	
7		9		MAJOR		MAJOR		VENDOR'S STANDARD		MAJOR		VENDOR'S STANDARD	
8		10		MAJOR		MAJOR		AS PERAPPROVED DATASHEET/ DRAWING		MAJOR		AS PERAPPROVED DATASHEET/ DRAWING	
9		11		MAJOR		MAJOR		ACTUATOR +VALVE		MAJOR		ACTUATOR +VALVE	

SL. NO.	CHARACTERISTICS	CLASS	TYPE OF CHECK	QUANTUM OF CHECK	REFERENCE DOCUMENT	ACCEPTANCE NORMS	FORMAT OF RECORDS	AGENCY	REMARKS
3.5	DIMENSION & WALL THICKNESS CHECK	MAJOR	MEASUREMENT	ALL VALVES	AS PERDRAWING		TC	P	V
3.6	NDE MACHINED	MAJOR	PT	ALL VALVES	ASMESEC. V/VIII/HW0980829		TC	P	V
3.7	FUNCTION / PERFORMANCE TEST	MAJOR	PERFORMANCE	ALL VALVES	AS PERAPPROVED DATASHEET/ DRAWING		TC	P	W
3.8	NOISELEVEL	MAJOR	NOISETEST					P	V
3.9	CV TEST	MAJOR	CV TEST	PERDESIGN	AS PERAPPROVED DATASHEET/ DRAWING		TC	P	V
	PAINTING,PACKLING AND PRESERVATION	MAJOR	VISUAL	ALL VALVES	VENDOR'S STANDARD			P	

MANUFACTURER'S NAME AND ADDRESS		STANDARD QUALITY PLAN		TO BE FILLED BY BHEL	
BHEL		VENDOR'S NAME		LP BYPASS SYSTEM	
DRG. NO.		AS PER PO		TYPE OF CHECK	
SPEC.		AS PER PO		5	
REV		02		3	
CHARACTERISTICS		3		MAJOR	
COMPONENT & OPERATIONS		2		MAJOR	
1		4		MAJOR	
2		6		MAJOR	
3		8		MAJOR	
4		10		MAJOR	
5		11		MAJOR	

LEGEND:
 I: RECORDS IDENTIFIED WITH 'TICK' SHALL BE ESSENTIALLY INCLUDED BY CONTRACTOR IN QA DOCUMENTATION.
 M: MANUFACTURER / SUBCONTRACTOR B: BHEL / NOM. INSPECTION AGENCY N: CUSTOMER
 INDICATE 'P' PERFORM 'W' WITNESS AND 'V' VERIFICATION
 ALL 'W' INDICATED IN COLUMN 'N' SHALL BE 'CHP' OF CUSTOMER

APPROVED BY

Sanjeev
 27/01/15

संजीव कुमार भारद्वाज
 Sanjeev Kumar Bhardwaj
 अभियन्ता/Engineer

गुणत आश्वासन/Quality Assurance
 बी. एच. ई. एल., इंदौर/BHEL Indore

23

MANUFACTURER'S NAME AND ADDRESS		STANDARD QUALITY PLAN				TO BE FILLED BY BHEL				TO BE FILLED BY BHEL			
BHEL		VENDOR'S NAME		LP BYPASS SYSTEM		QP NO. DATED		QA/BI/OP/114		10/09/2014			
		DRG. NO.		AS PER PO									
		SPEC.		AS PER PO									
		REV		02									
SL. NO.		COMPONENT & OPERATIONS		CHARACTERISTICS		CLASS		TYPE OF CHECK		QUANTUM OF CHECK		REFERENCE DOCUMENT	
1		2		3		4		5		6		7	
												8	
												9	
												10	
												11	

SL. NO.	COMPONENT & OPERATIONS	CHARACTERISTICS	CLASS	TYPE OF CHECK	QUANTUM OF CHECK	REFERENCE DOCUMENT	ACCEPTANCE NORMS	FORMAT OF RECORDS	AGENCY	REMARKS			
1	2	3	4	5	6	7	8	9	M	B	N	10	11
1	INCOMING MATERIAL CONTROL												
1.1	OILTANK	DAMAGE	MAJOR	VISUAL	100%	MANUFACTURERDRAWING		COC			P	V	
		DIMENSIONS	MINOR	MEASUREMENT	100%	MANUFACTURERDRAWING		COC			P	V	
		VERIFICATION OF SUPPLIER CERTIFICATE, IDENTIFICATION & CORRELATION FOR RAW MATERIAL PLATES	MAJOR	CERTIFICATE REVIEW	100%	MANUFACTURERDRAWING		COC			P	V	
1.2	BOUGHT OUT ITEMS												
	LEVEL TRANSMITTER	DAMAGE, RUST	MAJOR	VISUAL	100%	DRG./DATASHEET		COC			P	V	
		MODEL CODE	MAJOR	VISUAL	100%	DRG./DATASHEET		COC			P	V	
		CALIBRATION	MAJOR	VISUAL	100%	DRG./DATASHEET		COC			P	V	
	PRESSURE TRANSMITTER	DAMAGE, RUST	MAJOR	VISUAL	100%	DRG./DATASHEET		COC			P	V	
		MODEL CODE	MAJOR	VISUAL	100%	DRG./DATASHEET		COC			P	V	
		CALIBRATION	MAJOR	VISUAL	100%	DRG./DATASHEET		COC			P	V	
	TEMPERATURE TRANSMITTER	DAMAGE, RUST	MAJOR	VISUAL	100%	DRG./DATASHEET		COC			P	V	
		MODEL CODE	MAJOR	VISUAL	100%	DRG./DATASHEET		COC			P	V	
		CALIBRATION	MAJOR	VISUAL	100%	DRG./DATASHEET		COC			P	V	

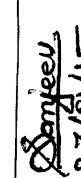
MANUFACTURER/SUB CONTRACTOR		FOR CUSTOMER USE	
LEGEND: I: RECORDS IDENTIFIED WITH 'TICK' SHALL BE ESSENTIALLY INCLUDED BY CONTRACTOR IN QA DOCUMENTATION. M: MANUFACTURER / SUBCONTRACTOR B: BHEL / NOM. INSPECTION AGENCY N: CUSTOMER INDICATE 'P' PERFORM 'W' WITNESS AND 'V' VERIFICATION ALL 'W' INDICATED IN COLUMN 'N' SHALL BE 'CHP' OF CUSTOMER		APPROVED BY	
		 Sanjeev 27/01/15 संजीव कुमार भारद्वाज Sanjeev Kumar Bhatnagar अभियन्ता/Engineer गुणता अश्वासन/Quality Assurance बी. एच. ई. एन., इंदौर/BHEL, Indore.	

22

MANUFACTURER'S NAME AND ADDRESS		STANDARD QUALITY PLAN				TO BE FILLED BY BHEL			TO BE FILLED BY BHEL		
VENDOR'S NAME		LP BYPASS SYSTEM		QP NO.	QA/BI/QP/114	REFERENCE DOCUMENT			AGENCY		
BHEL				DATED	10/09/2014	7			M	B	N
SL. NO.		CHARACTERISTICS		CLASS	TYPE OF CHECK	QUANTUM OF CHECK	8	9	D	11	
1		3		4	5	6	8	9	D	11	

SL. NO.	COMPONENT & OPERATIONS	CHARACTERISTICS	CLASS	TYPE OF CHECK	QUANTUM OF CHECK	REFERENCE DOCUMENT	ACCEPTANCE NORMS	FORMAT OF RECORDS	AGENCY	REMARKS	
1	2	3	4	5	6	7	8	9	M	B	N
	THREEPHASE MOTORS	DAMAGE, RUST	MAJOR	VISUAL	100%	DRG./DATASHEET		COC	N	P	V
		MODEL CODE	MAJOR	VISUAL	100%	DRG./DATASHEET		COC	N	P	V
		VERIFICATION OF SUPPLIER CERTIFICATE	MAJOR	VISUAL	100%	DRG./DATASHEET		COC	N	P	V
	ACCUMUFATOR S	DAMAGE, RUST	MAJOR	VISUAL	100%	DRG./DATASHEET		COC	N	P	V
		MODEL CODE	MAJOR	VISUAL	100%	DRG./DATASHEET		COC	N	P	V
		PRESSURE TEST	MAJOR	VISUAL	100%	DRG./DATASHEET		COC	N	P	V
	PRESSURE RELIEF VALVES	DAMAGE, RUST	MAJOR	VISUAL	100%	DRG./DATASHEET		COC	N	P	V
		MODEL CODE	MAJOR	VISUAL	100%	DRG./DATASHEET		COC	N	P	V
		ADJUSTMENT	MAJOR	VISUAL	100%	DRG./DATASHEET		COC	N	P	V
	PRESSURE GUAGES	DAMAGE, RUST	MAJOR	VISUAL	100%	DRG./DATASHEET		COC	N	P	V
		MODEL CODE	MAJOR	VISUAL	100%	DRG./DATASHEET		COC	N	P	V
		CALIBRATION	MAJOR	VISUAL	100%	DRG./DATASHEET		COC	N	P	V
	THERMOMETER	DAMAGE, RUST	MAJOR	VISUAL	100%	DRG./DATASHEET		COC	N	P	V
	CF AIR COOLER	DAMAGE, RUST	MAJOR	VISUAL	100%	DRG./DATASHEET		COC	N	P	V
	COOLING CUM FILTRATION	DAMAGE, RUST	MAJOR	VISUAL	100%	DRG./DATASHEET		COC	N	P	V

MANUFACTURER/SUB CONTRACTOR		FOR CUSTOMER USE		APPROVED BY	
		LEGEND:		 27/01/15 संजीव कुमार भारद्वाज Sanjeev Kumar Bhardwaj अभियन्ता/Engineer	
		! RECORDS IDENTIFIED WITH 'TICK' SHALL BE ESSENTIALLY INCLUDED BY CONTRACTOR IN QA DOCUMENTATION. M: MANUFACTURER / SUBCONTRACTOR B: BHEL / NOM. INSPECTION AGENCY N: CUSTOMER INDICATE 'P' PERFORM 'W' WITNESS AND 'V' VERIFICATION ALL 'W' INDICATED IN COLUMN 'N' SHALL BE 'CHP' OF CUSTOMER			

गुणत आश्वासन/Quality Assurance
 बी. एच. ई. एल., हरियाणा BHEL Haridwar

21

MANUFACTURER'S NAME AND ADDRESS		STANDARD QUALITY PLAN				TO BE FILLED BY BHEL		TO BE FILLED BY BHEL		
BHEL		VENDOR'S NAME		LP BYPASS SYSTEM	QA/BI/QP/114					
		DRG. NO.	AS PER PO	Q.P. NO.	DATED					
		SPEC.	AS PER PO		10/09/2014					
		REV	02							
SL. NO.	COMPONENT & OPERATIONS	CHARACTERISTICS	CLASS	TYPE OF CHECK	QUANTUM OF CHECK	REFERENCE DOCUMENT	ACCEPTANCE NORMS	FORMAT OF RECORDS	AGENCY	REMARKS
1	2	3	4	5	6	7	8	9	M B N	10
										11

2	CFPUMPS	DAMAGE, RUST	MAJOR	VISUAL	100%	DRG./DATASHEET		COC	N	P	
	GEARPUMPS	DAMAGE, RUST	MAJOR	VISUAL	100%	DRG./DATASHEET		COC	N	P	
	COUPLING	DAMAGE, RUST	MAJOR	VISUAL	100%	DRG./DATASHEET		COC	N	P	
	FILTERS	DAMAGE, RUST	MAJOR	VISUAL	100%	DRG./DATASHEET		COC	N	P	
2	FUNCTION TEST /FINAL INSPECTION										
2.1	HPSU	DIMENSIONS	MAJOR	MEASUREMENT	100%						
2.2	HPSU	CORRECT FITMENT	MAJOR	VISUAL	100%	AS PER DRAWING		TC	N	P	W
2.3	HPSU	FUNCTION TEST	MAJOR	MEASUREMENT	100%	AS PER DRAWING/CIRCUIT DIAGRAM		TC	N	P	W
2.4	HPSU	PAINTING	MAJOR	VISUAL	100%	FP_0019		TC	N	P	W
						DRG./VENDORPROCEDURE			N	P	

MANUFACTURER/SUB CONTRACTOR	FOR CUSTOMER USE		APPROVED BY
	LEGEND: I: RECORDS IDENTIFIED WITH 'TICK' SHALL BE ESSENTIALLY INCLUDED BY CONTRACTOR IN QA DOCUMENTATION. M: MANUFACTURER / SUBCONTRACTOR B: BHEL / NOM. INSPECTION AGENCY N: CUSTOMER INDICATE 'P' PERFORM 'W' WITNESS AND 'V' VERIFICATION ALL 'W' INDICATED IN COLUMN 'N' SHALL BE 'CHP' OF CUSTOMER		 27/01/15 संजीव कुमार भारद्वाज Sanjeev Kumar Bhardwaj अभियन्ता/Engineer

गुणता आश्वासन/Quality Assurance
बी. एच. ई. एल., हरियाणा/BHEL Haridwar

MANUFACTURER'S NAME AND ADDRESS		STANDARD QUALITY PLAN				TO BE FILLED BY BHEL				TO BE FILLED BY BHEL											
BHEL		VENDOR'S NAME		LP BYPASS SYSTEM		QP NO.		QA/B/JP/114		M		B		N							
		DRG. NO.		AS PER PO		DATED		10/09/2014		9		D		10							
		SPEC.		AS PER PO						8											
		REV		02						7											
SL. NO.		COMPONENT & OPERATIONS		CHARACTERISTICS		CLASS		TYPE OF CHECK		QUANTUM OF CHECK		REFERENCE DOCUMENT		ACCEPTANCE NORMS		FORMAT OF RECORDS		AGENCY		REMARKS	
1		2		3		4		5		6		7		8		9		10		11	

WATER INJECTION VALVES

1.0	RAW MATERIAL																				
1.1	BODY & BONNET	A. CHEMICAL COMPOSITION	MAJOR	CHEMICAL ANALYSIS	PERHEAT	AS PER APPROVED DATASHEET															
		B. MECHANICAL PROPERTIES	-	MECH. TEST	PERHEAT	AS PER APPROVED DATASHEET															
		C. APPEARANCE	-	VISUAL INSPECTION	PERLOT	MSS SP-55															
1.2	STUDS & NUTS	A. CHEMICAL COMPOSITION	MAJOR	CHEMICAL ANALYSIS	PERHEAT	EN 10204 TYPE 3.1 ASTM A193 B7															
		MECHANICAL PROPERTIES	-	MECH. TEST	PERHEAT	ASTM A194 2H															
2.0	ASSEMBLY					EN 10204 TYPE 3.1 ASTM A193 B7															
						ASTM A194 2H															
2.1	STEM	DIMENSION / VISUAL	MAJOR	VISUAL & DIMENSIONAL INSPECTION	PERLOT	DRAWING															
2.2	PLUG	DIMENSION / VISUAL	MAJOR	VISUAL & DIMENSIONAL INSPECTION	PERLOT	DRAWING															
2.3	SEATING	DIMENSION / VISUAL	MAJOR	VISUAL & DIMENSIONAL INSPECTION	PERLOT	DRAWING															
2.4	BODY ASSLY	A. HYDRO	MAJOR	HYDRO	ALL VALVES	AS PER APPROVED DATASHEET/ DRG.															
		B. SEATLEAKAGE	MAJOR	LEAKAGE	ALL VALVES	AS PER APPROVED DATASHEET/ DRG.															
		C. FUNCTION	MAJOR	•FUNCTION •DIMENSION •PAINT	ALL VALVES	AS PER APPROVED DATASHEET/ DRG.															

LEGEND:

! RECORDS IDENTIFIED WITH 'TICK' SHALL BE ESSENTIALLY INCLUDED BY CONTRACTOR IN QA DOCUMENTATION.

M: MANUFACTURER / SUBCONTRACTOR B: BHEL / NOM. INSPECTION AGENCY N: CUSTOMER

INDICATE 'P' PERFORM 'W' WITNESS AND 'V' VERIFICATION

ALL 'W' INDICATED IN COLUMN 'N' SHALL BE 'CHP' OF CUSTOMER

FOR CUSTOMER USE

APPROVED BY

Sanjeev

27/01/15

संजीव कुमार भारद्वाज

Sanjeev Kumar Bhardwaj

अभियंता/Engineer

गुणता आश्वासन/Quality Assurance

बी. एच. ई. एल., हरियाणा/BHEL Haryana

MANUFACTURER'S NAME AND ADDRESS				STANDARD QUALITY PLAN				TO BE FILLED BY BHEL				TO BE FILLED BY BHEL									
VENDOR'S NAME		ITEM		LP BYPASS SYSTEM		QP NO. DATED		QA/BI/QP/114		10/09/2014											
BHEL		DRG. NO.		AS PER PO																	
		SPEC.		AS PER PO																	
		REV		02																	
SL. NO.		COMPONENT & OPERATIONS		CHARACTERISTICS		CLASS		TYPE OF CHECK		QUANTUM OF CHECK		REFERENCE DOCUMENT		ACCEPTANCE NORMS		FORMAT OF RECORDS		REMARKS			
1		2		3		4		5		6		7		8		9		10		11	
2.5	TOPASSLY	A. DEMENSION / VISUAL B. PAINT C. PACKING	MAJOR	DIMENSIONAL / VISUAL VISUAL VISUAL	ALL VALVES ALL VALVES ALL VALVES	TOPASSLY DRWG. VENDOR'S STANDARD BHELP O. VENDOR'S STANDARD															

MANUFACTURER/SUB CONTRACTOR	FOR CUSTOMER USE		APPROVED BY संजीव कुमार भारद्वाज Sanjeev Kumar Bhardwaj अभिियन्ता/Engineer
	LEGEND: ! RECORDS IDENTIFIED WITH 'TICK' SHALL BE ESSENTIALLY INCLUDED BY CONTRACTOR IN QA DOCUMENTATION. M: MANUFACTURER / SUBCONTRACTOR B: BHEL / NOM. INSPECTION AGENCY N: CUSTOMER INDICATE 'P' PERFORM 'W' WITNESS AND 'V' VERIFICATION ALL 'W' INDICATED IN COLUMN 'N' SHALL BE 'CHP' OF CUSTOMER		

गुणता आश्वासन/Quality Assurance
बी. एच. ई. एल., हरियाणा/BHEL Hariana

MANUFACTURER'S NAME AND ADDRESS		STANDARD QUALITY PLAN				TO BE FILLED BY BHEL		TO BE FILLED BY BHEL						
VENDOR'S NAME		LP BYPASS SYSTEM		QP NO.	QA/BI/OP/114									
BHEL		AS PER PO		DATED	10/09/2014									
SL. NO.		DRG. NO.		AS PER PO										
1		SPEC.		AS PER PO										
2		REV		02										
3		CHARACTERISTICS		CLASS	TYPE OF CHECK	QUANTUM OF CHECK	REFERENCE DOCUMENT	ACCEPTANCE NORMS	FORMAT OF RECORDS	AGENCY	REMARKS			
2		3		4	5	6	7	8	9	M	B	N	10	11

FLOW NOZZLE FOR WIV														
1.0	RAW MATERIAL													
	BRANCH PIPE	A. CHEMICAL COMPOSITION	MAJOR	CHEMICAL ANALYSIS		PER LOT		AS PER APPROVED DATASHEET/ DRG.	TC					
		B. MECHANICAL PROPERTIES		-MECH. TEST				AS PER APPROVED DATASHEET/ DRG.	TC					
		C. NDT		UT				AS PER APPROVED DATASHEET/ DRG.	TC					
	FLOW NOZZLE	A. CHEMICAL COMPOSITION	MAJOR	CHEMICAL ANALYSIS		-DO-		AS PER APPROVED DATASHEET/ DRG.	TC					
		B. MECHANICAL PROPERTIES		-MECH. TEST				AS PER APPROVED DATASHEET/ DRG.	TC					
2.0	MANUFACTURING							AS PER APPROVED DATASHEET/ DRG.	TC					
2.1	MACHINING PARTS	VISUAL & DIMENSIONAL INSPECTION	MAJOR	VISUAL/ DIMENSIONAL		PER PIECE		SHOP TRAVELER						
2.2	WELDING & HEAT TREATMENT	SEEDRAWING	MAJOR			PER PIECE		EN288 /ASMEIX						
2.3	ASSEMBLY	SEEDRAWING	MAJOR	VISUAL		PER DESIGN		AS PER APPROVED DATASHEET/ DRG.						
3.0	TESTING & INSPECTION													
3.1	NDE WELDING	RT OR UT	MAJOR	RT/UT		PER PIECE		ASMESECV/VIII/HW/0980830	TC					
	NDE MACHINED WELD END	PT	MAJOR	PT		PER PIECE		ASMESECV/VIII/HW/0980830	TC					
3.2	HYDROSTATIC PRESSURE TEST	PRESSURE TEST	MAJOR	HYDRO		PER PIECE		AS PER APPROVED DATASHEET/ DRG./Follow HW/0980829	TC					

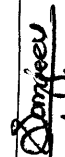
MANUFACTURER/SUB CONTRACTOR		FOR CUSTOMER USE	
LEGEND: ! RECORDS IDENTIFIED WITH 'TICK' SHALL BE ESSENTIALLY INCLUDED BY CONTRACTOR IN QA DOCUMENTATION. M: MANUFACTURER / SUBCONTRACTOR B: BHEL / NOM. INSPECTION AGENCY N: CUSTOMER INDICATE 'P' PERFORM 'W' WITNESS AND 'V' VERIFICATION ALL 'W' INDICATED IN COLUMN 'N' SHALL BE 'CHP' OF CUSTOMER		APPROVED BY	
		 27/01/15 संजीव कुमार भारद्वाज Sarjeev Kumar Bhardwaj अभियन्ता/Engineer गुणता आश्वासन/Quality Assurance बी. एच. ई. एल., हरिद्वार/BHEL Haridwar	

MANUFACTURER'S NAME AND ADDRESS		STANDARD QUALITY PLAN				TO BE FILLED BY BHEL			TO BE FILLED BY BHEL								
VENDOR'S NAME		LP BYPASS SYSTEM		OP NO.	QA/BI/OP/114												
BHEL				DATED	10/09/2014												
DRG. NO.		AS PER PO															
SPEC.		AS PER PO															
REV		02															
CHARACTERISTICS		CLASS		TYPE OF CHECK		QUANTUM OF CHECK		REFERENCE DOCUMENT		ACCEPTANCE NORMS		FORMAT OF RECORDS		AGENCY		REMARKS	
1	2	3	4	5	6	7	8	9	D	10	11						

3.3	DIMENSION CHECK	WELDEND + MAIN DIMENSION	MAJOR	DIMENSIONAL	PERPIECE	DRAWING	TC	N	P	W		
3.4	CALIBRATION REPORT		MAJOR	VISUAL	PERPIECE		COC	N	P	V		
4	FINAL INSPECTION PACK -& SHIPPING	VERIFICATION OF COMPLETION STAMPING PACKING	MAJOR	VISUAL	100%	AS PER APPROVED DRAWING/ DATASHEET	COC	N	P	V		

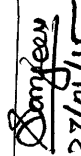
MANUFACTURER/SUB CONTRACTOR		FOR CUSTOMER USE		APPROVED BY	
		LEGEND: ! RECORDS IDENTIFIED WITH 'TICK' SHALL BE ESSENTIALLY INCLUDED BY CONTRACTOR IN QA DOCUMENTATION. M: MANUFACTURER / SUBCONTRACTOR B: BHEL / NOM. INSPECTION AGENCY N: CUSTOMER INDICATE 'P' PERFORM 'W' WITNESS AND 'V' VERIFICATION ALL 'W' INDICATED IN COLUMN 'N' SHALL BE 'CHP' OF CUSTOMER		 27/01/15 संजीव कुमार भारद्वाज Sanjeev Kumar Bharadwaj अभियन्ता/Engineer गुणता आश्वासन/Quality Assurance बी. एच. ई. एल., हरद्वार/BHEL Haridwar	

MANUFACTURER'S NAME AND ADDRESS		STANDARD QUALITY PLAN				TO BE FILLED BY BHEL				TO BE FILLED BY BHEL			
VENDOR'S NAME		LP BYPASS SYSTEM		QP NO.	QA/BI/QP/114								
BHEL		DRG. NO.		DATED	10/09/2014								
		SPEC.		AS PER PO									
		REV		AS PER PO									
		CHARACTERISTICS		02									
SL. NO.		COMPONENT & OPERATIONS		CLASS	QUANTUM OF CHECK	TYPE OF CHECK	REFERENCE DOCUMENT	ACCEPTANCE NORMS	FORMAT OF RECORDS	AGENCY		REMARKS	
1	2	3	4	5	6	7	8	9	D	M	B	N	11

DUMP TUBE

1.0	RAW MATERIAL												
1.1	DUMP TUBE	A. CHEMICAL COMPOSITION	MAJOR	CHEMICAL ANALYSIS	PERHEAT	AS PER APPROVED DATASHEET							
		B. MECHANICAL PROPERTIES	MAJOR	-MECH. TEST	PERHEAT	AS PER APPROVED DATASHEET							
		C. NDT	MAJOR	UT	100	AS PER APPROVED DATASHEET							
2.0	IN PROCESS												
2.1	WELDING & HEAT TREATMENT	WPS	MAJOR	VISUAL TIME/TEMPERATURE	PERPIECE	ASMEIX / EN288							
2.2	NDE WELDING	RT MPI/DPT	MAJOR	RT MPI/DPT	PERPIECE	ASMESEC. V/VIII/ HW0980830							

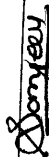
MANUFACTURER/SUB CONTRACTOR		FOR CUSTOMER USE		APPROVED BY	
		LEGEND: I: RECORDS IDENTIFIED WITH 'TICK' SHALL BE ESSENTIALLY INCLUDED BY CONTRACTOR IN QA DOCUMENTATION. M: MANUFACTURER / SUBCONTRACTOR B: BHEL / NOM. INSPECTION AGENCY N: CUSTOMER INDICATE 'P' PERFORM 'W' WITNESS AND 'V' VERIFICATION ALL 'W' INDICATED IN COLUMN 'N' SHALL BE 'CHP' OF CUSTOMER		 27/09/15 संजीव कुमार भारद्वाज Sanjeev Kumar Bharadwaj अभियंता/Engineer गुणता आश्वासन/Quality Assurance बी. एच. ई. एल., हरिद्वार/BHEL Haridwar	