

SIGN & DATE		HP RELIEF VALVE LIST OF DOCUMENTS AND DRAWINGS	413137U4005
			Rev.0
			Page 1 of 1

SUPERSEDES INVENTORY

A. SCOPE OF THE DOCUMENT:

This document lists down the drawings and documents to be followed for executing the order of one number of HP Relief Valve.

B. LIST OF DOCUMENTS AND DRAWINGS:

S.no.	Item description	Drawing / Document no.	Rev/ Index
1	Specification – HP Relief valve with pneumatic actuator	413137U4100 ->	
2	HP Relief valve drg	4-13137-U3201	
3	Technical purchasing specification: Valves	41313795102	
4	Electrical specs for limit switch and solenoid valves	41810221002	

COPYRIGHT AND CONFIDENTIAL
 The information on this documents is the property of Bharat Heavy Electrical Limited. It must not be used directly or indirectly in any way detrimental to the interest of the company



SIGN & DATE

CIE	S Srivastava		PED	Navneet	
AGREED DEPTT.	NAME	DATE & SIGNATURE	DEPTT	NAME	SIGNATURE & DATE

No.	Item	Specifications – HP Relief Valve with Pneumatic Actuator																																										
1.	Doc no. Rev no.	413137U4100 00																																										
2.	Basic data: Valve Body Material : ASTM-A182F22 Inlet connection : 168.3 X 10.97 mm Outlet connection : 273.1 X 7.8 mm <table border="1" data-bbox="239 608 1423 968"> <thead> <tr> <th rowspan="2">Pos*</th> <th rowspan="2">Description</th> <th colspan="2">Dimension acc to ASME B36.10M</th> <th colspan="3">Connection</th> <th rowspan="2">Material</th> </tr> <tr> <th>NPS</th> <th>Schedule</th> <th>Type</th> <th>Form/Figure</th> <th>Standard</th> </tr> </thead> <tbody> <tr> <td>G23</td> <td>Inlet at HP Relief Valve</td> <td>6"</td> <td>80</td> <td>Butt Weld</td> <td>5B</td> <td>ASME B16.25</td> <td>ASTM-A182F22</td> </tr> <tr> <td>G24</td> <td>Outlet at HP Relief Valve</td> <td>10"</td> <td>30</td> <td>Butt Weld</td> <td>4</td> <td>ASME B16.25</td> <td>ASTM-A182F12</td> </tr> <tr> <td>T840</td> <td>Control Air Connection at HP Relief Valve</td> <td>-</td> <td>-</td> <td>Thread</td> <td>-</td> <td>EN ISO 228-1</td> <td>-</td> </tr> </tbody> </table> <p>*See Indicative Drawing for details.</p>							Pos*	Description	Dimension acc to ASME B36.10M		Connection			Material	NPS	Schedule	Type	Form/Figure	Standard	G23	Inlet at HP Relief Valve	6"	80	Butt Weld	5B	ASME B16.25	ASTM-A182F22	G24	Outlet at HP Relief Valve	10"	30	Butt Weld	4	ASME B16.25	ASTM-A182F12	T840	Control Air Connection at HP Relief Valve	-	-	Thread	-	EN ISO 228-1	-
Pos*	Description	Dimension acc to ASME B36.10M		Connection			Material																																					
		NPS	Schedule	Type	Form/Figure	Standard																																						
G23	Inlet at HP Relief Valve	6"	80	Butt Weld	5B	ASME B16.25	ASTM-A182F22																																					
G24	Outlet at HP Relief Valve	10"	30	Butt Weld	4	ASME B16.25	ASTM-A182F12																																					
T840	Control Air Connection at HP Relief Valve	-	-	Thread	-	EN ISO 228-1	-																																					
3.	Valve design	Spindle				vertical																																						
		Steam Flow Direction				Under the valve cone																																						
		Fittings				Perforated cage																																						
		KVS-Valve				200 m ³ /h																																						
		Seat diameter				According to tech. design																																						
		Valve stroke				According to tech. design																																						
		Spindle sealing				Graphite																																						
		Leakage Class				EN 1349-Seat leakage IV L1 (0.01% KVS value)																																						
		Valve welding ends acc.to.				ASME B 16.25 Fig. 4 & 5 B																																						
4.	Pneumatic Actuator	Spring Working Direction				Opens the valve																																						
		Control Air Working Direction				Closes the valve																																						
		Solenoid valves idle				Opens the valve																																						
		Travel Time (100% stroke)				Open ≤ 1 sec. Close ≤ 2 sec.																																						

		Control Air Connection acc. to	G3/4" (Type Thread as per EN ISO 228-1)
		Pressure of control air	5 bar ≤ p < 10 bar
		Min available Control Air Pressure for the design of the actuator	5 bar
		Design differential pressure of actuator	≥ 78.0 bar
		Additional force of the actuator	≥ 20 %
5.	Equipment	3/2-Way-Solenoid valves , connected in series. All pneumatic components are piped. All electrical equipments are wired to a terminal box.	2 pieces
		3/2-way pneumatic valve	2 pieces
		Proximity switch OPEN:	1 piece
		Proximity switch CLOSE:	1 piece
		Filter Regulator with pressure gauge: Adjustment range 0-10 bar, adjusted and sealed at 5 bar	1 piece
6.	Design parameter	Pressure [bar abs]	Temperature [°C]
	Maximal long term	61.5	368
	Maximal short term:	72.3	430
	15 min. per event and max.10,000h of lifetime	20.0	480
	1000 h	20.0	510
	1 min per single event	77.0	510
	The following design data of the adjacent pipes have to be considered:		
	MAWP/MAWT Valve inlet	78.0	510
	MAWP/MAWT Valve outlet	38.0	433
	Maximum temperature difference in operation between valve inlet and valve outlet in design case maximal long term	324°C	
	Minimal pressure at the valve outlet, approx.	0.1 bar (a)	
7.	Seismic Requirements:	Safe operation	Horizontal: 0.3g Vertical: 0.2 g

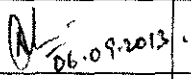
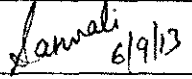
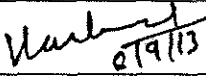
8.	Installation	Indoor	
	Ambient Conditions	Ambient Temperature min/max	0°C / 50°C
		Absolute Humidity	≥ 60 g/m ³
9.	KKS Labeling	Unit code	
	HP-Relief Valve	1 0LBC41AA051	
	3/2-Way Solenoid Valve 1	1 0LBC41AA051A	
	3/2-Way Solenoid Valve 2	1 0LBC41AA051B	
	3/2-Way Pneumatic Valve 1	1 0LBC41AA051C	
	3/2-Way Pneumatic Valve 2	1 0LBC41AA051D	
	Proximity Switch – Position 100% OPEN	1 0LBC41CG051B	
	Proximity Switch – Position 0% CLOSE	1 0LBC41CG051C	
	Air filter	1 0LBC41AT021	
	Pressure Relief Valve	1 0LBC41AA261	
	Pressure Gauge	1 0LBC41CP501	
	Terminal Box	1 0LBC41GF051	
10.	Further Requirements;	We expect in the scope of the agreed quality documentation at least the procurement according to article 10, PED directive 97/23/EC required conformity declaration. The classification of the pressure equipment on the basis of the given layout data in the order (fluid, pressure, volume, nominal size, max temperature) are incumbent on the supplier. As well, the choice of the corresponding conformity quality processes is to carry out by the supplier. The quality declaration must contain all details according to appendix VII of the directive 97/23/EC.	

Prepared by		Approved by	
 06.09.2013	 6/9/13	 6/9/13	
Navneet Chakrapani	Ms Saswati Srivastava	S K Gupta	B S Rana
Engr- PED	SM-CIE	SDGM-PED	SDGM-CIE

COPYRIGHT AND CONFIDENTIAL
 THE INFORMATION ON THIS DOCUMENT IS THE PROPERTY OF BHARAT HEAVY
 ELECTRICALS LIMITED. IT MUST NOT BE USED DIRECTLY OR INDIRECTLY IN
 ANY WAY DETRIMENTAL TO THE INTEREST OF THE COMPANY.

DRAWING NO.

(DIM FOR DISASSEMBLY)

VALVE TAG NUMBER : LBC41AA051

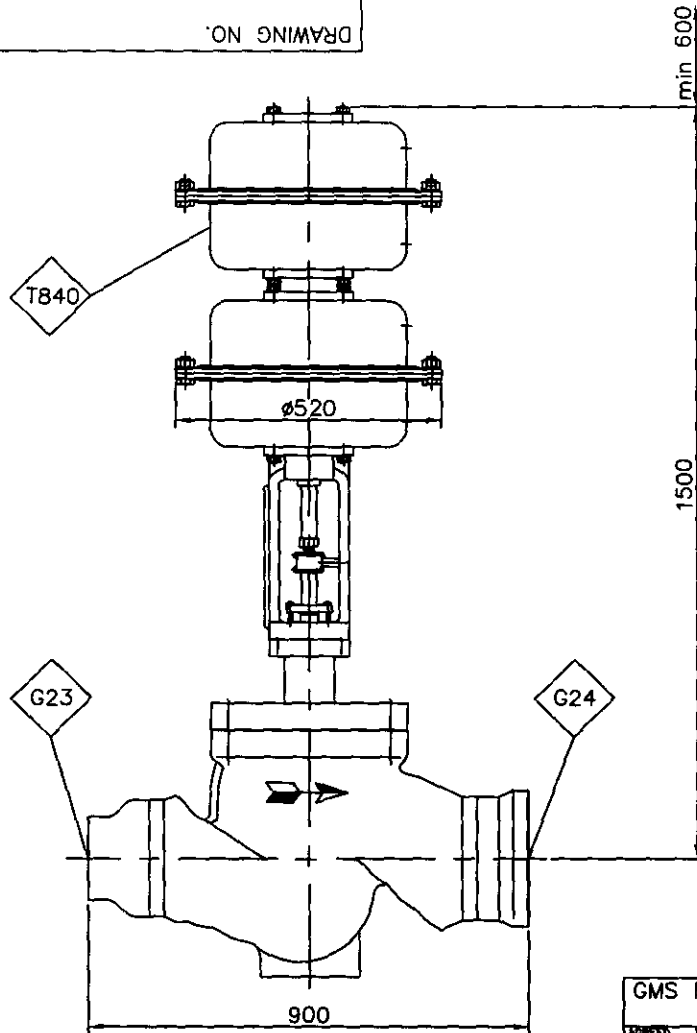

INVENTORY NO.	SIGN & DATE	REF. DRG. NO.	GMS NO./GR SP NO				STATUS OF DRG				TYPE OF PRODUCT							
			NAME		SIGN	DATE	NAME		SIGN	DATE	NAME		SIGN	DATE	NO. OF			
			GRADE OF UNTOL DIM :-				BHARAT HEAVY ELECTRICALS LTD. HARDWAR				DRN P.S.SHARMA		-SD-	6.8.13	VAR.			
			M/CG-C/M/F AA0230208								CHD NAVNEET		-SD-	6.8.13				
			WELDING-A/B/C/D AA0621104								APD S.K.GUPTA		-SD-	6.8.13				
			GAS CUTTING-'T3'AA0621101								REF TO ASSY DRG.		ITEM NO	NO OF ITEMS				
			REV	DATE	ALTERED	CHECKED	REV	DATE	ALTERED	CHECKED	DEPT PED		SCALE	WEIGHT (kg)	REF TO ASSY DRG.		ITEM NO	NO OF ITEMS
											CODE 4266		N.T.S.	---	REF TO ASSY DRG.		ITEM NO	NO OF ITEMS
											TITLE				CARD CODE	DRAWING NO.		REV.
											HP RELIEF VALVE					4-13137-U3201		00
															SHEET NO. 01		NO.OF SHEETS 01	

Table of content		page
1	Scope of Application	2
2	Type-tested Valves	2
3	Referenced Documents	2
4	Technical Data and Design.....	2
5	Inspection certificate / Declaration of Compliance in Dependence on Fluid, Pressure and Temperature	2
6	QA-Requirements regarding the Valve Manufacturer and his Suppliers	2
7	Manufacturing and Inspection Plan (MIP)	3
8	Condition for Manufacturing.....	3
9	Fabrication and Inspection.....	3
9.1	Steel Castings	3
9.2	Rolled or Forged Material.....	3
9.3	Connecting Elements	3
9.4	Welding.....	3
9.5	Manufacturing Inspections	4
10	Marking	4
11	Surface Protection	4
12	Documentation.....	5
13	Final inspection.....	5
14	Delivery and Packing.....	5
15	Guarantee.....	6
16	Spares	6
17	Special Tools & Tackles	6
18	Supplementary Requirements.....	6
19	Deviations	6

Continued page 2 to 6

1 Scope of Application

This Technical Purchasing Specification covers valves for evacuating of bottled up pressurized steam from steam turbine unit during load throw-off. During normal operation of turbine, this valve shall remain in tightly closed position and down steam side of the valve shall be subjected to condenser vacuum. The valve is to be suitably designed to prevent the ingress of air through valve glands into the system.

The requirements of this specification are valid as far as no other requirements are given in the enquiry.

2 Type-tested Valves

Valves with a valid type-testing certificate according to PED97/23/EC and to the corresponding VdTÜV-Merkblätter, of TRD 110 attachment 1 as well as accordingly to the registration of DIN-DVGW fulfill the requirements of this specification.

For these valves the requirements for manufacturing and testing agreed upon with the TÜVs respectively with the DVGW-federation shall be fulfilled (declaration of commitment).

3 Referenced Documents

- AD2000-W 0
- AD2000-W 7
- AD2000-HP 0
- AD2000-HP 5/3
- TRD 100
- EN 287-1
- DIN EN ISO 15607
- DIN EN ISO 15609-1
- DIN EN ISO 15614-1
- EN 1418
- EN 10028
- EN 10204
- EN 10213
- EN 10222
- EN 10273
- DIN 1690-10
- EN 1559-1
- EN 1559-2
- EN 12266-1/-2
- DIN 17175,
- PED 97/23/EC

In case of differences or contradictions of the referenced documents the higher requirements shall be applied.

4 Technical Data and Design

The criteria, e.g. fluid, pressure, temperature, material of the casing, etc., as well as other technical data are given in the enquiry.

5 Inspection certificate / Declaration of Compliance in Dependence on Fluid, Pressure and Temperature

For all valves an Inspection Certification 3.1 according to EN 10204 must be provided.

6 QA-Requirements regarding the Valve Manufacturer and his Suppliers:

The valve manufacturer as well as his suppliers for the main components like e.g. pressure guiding components, instrumentation and control, shall have an introduced and well-working quality management system, e.g. according to EN ISO 9000 series or equivalent standard. Manufacturers of pressure guiding

components shall have in addition a certificate according to AD2000-W 0 respectively TRD 100.

As far as welding will be performed on the valves, the weld shop shall be certified according to AD2000-HP 0.

7 Manufacturing and Inspection Plan (MIP)

The valve manufacturer shall prepare a Manufacturing and Inspection Plan containing sufficient information on the sequence and extent of the valve inspections as well as the main raw material and shall deliver this to the purchaser for review at the latest 4 weeks after order receipt, but at least 2 weeks before starting manufacturing.

8 Condition for Manufacturing

Manufacturing of the valve mentioned in point 7 shall not be started before the review for the design as well as for the MIP has been given by the purchaser. To prohibit any delay the valve manufacturer shall call for missing reviews and remind the purchaser on time.

By reviewing the MIP the purchaser does not take on any responsibility for processes or manufacturing details of the valve manufacturer or his suppliers, or for the valve itself.

9 Fabrication and Inspection

9.1 Steel Castings

Steel castings, e.g. valve casings, covers, etc., shall be manufactured and inspected according to EN 10213 and EN 1559 part 1 and part 2 and DIN 1690 part 10, and following minimum requirements:

- Analysis (chemical composition) per heat
- Mechanical properties per heat and heat treatment batch, for castings with an individual weight > 1000 kg testing per casting
- Amount of non-destructive testing according to DIN 1690 part 10:
 - weld ends of valves without connection pieces: Quality class A with quality grades S1 + V1
 - transition areas: quality class B with quality grades S2 + V2
 - weld ends of valves with connection pieces: Quality class B with quality grades S2 + V2
- remaining areas of the casting: quality class D with quality grades S3 + V4; additionally for castings ≥ 500 kg or DN ≥ 400 mm each casting 100% volume inspection shall be performed.

9.2 Rolled or Forged Material

Rolled or forged material, e.g. connection piece, shall be manufactured and inspected according to the corresponding material standard, e.g. EN 10028, EN 10088, EN 10222, EN 10273, DIN EN 10216-2 and DIN 17440, etc. and following supplements:

- Analysis (chemical composition) per heat
- Mechanical properties per heat and heat treatment batch

9.3 Connecting Elements:

Connecting elements shall be manufactured and tested according to AD2000-W 7. As far as there is a requirement for a test certificate for grade properties, this shall be an inspection certificate 3.1 according to EN 10204.

9.4 Welding

As far as welding will be performed on the valves (also in case of fabrication welding on castings):

- Welding shall be performed only by welders tested in line with EN 287 or mechanized welds by welding operators tested in line with EN 1418
- Corresponding welding procedure specifications and procedure approval records according to
 - DIN EN ISO 15607
 - DIN EN ISO 15609-1
 - DIN EN ISO 15614-1 shall be available.
- Fabrication welds on castings shall be inspected according to DIN 1690.
- Fabrication welds having a length ≥ 150 mm or a depth $\geq 40\%$ of the wall thickness or a depth \geq

25 mm shall be recorded.

- Design welds shall be inspected according to AD2000-HP 5/3. In case of serial production manufacturer-specific inspection concepts may be applied with written agreement of the purchaser.
- If cast steel parts are subjected to heat treatment in the course of valve manufacture, all parts heated shall subsequently be subjected to a 100% surface crack examination.

9.5 Manufacturing Inspections

Manufacturing inspections shall be performed according to PED 97/23/EC / EN 12266. The PED 97/23/EC as a n superior legislation shall be observed and applied. These are especially:

- a) Pressure test
 - Test P10 according to EN 12266 part 1
- b) Leak test
 - Test P11 + P12, leakage class B according to EN 12266 part 1
- c) Functional test
 - Test F20 according to EN12266 part 2
- d) Verification of dimensions
 - Main dimensions
 - connecting dimensions

All tolerance ranges which are important for the function shall be recorded. as

 - Stem diameter
 - Diameters of guides and fits

10 Marking

Valves shall be marked as follows:

- The name and address or other means of identification of the manufacturer and, where appropriate, of his authorized representative established within the Community
- Nominal diameter
- Nominal pressure class
- Casing material
- Flow direction arrow
- Identification-no. (also commission-no.)
- The year of manufacture
- Identification of the pressure equipment according to its nature, such as type, series or batch identification and serial number
- Essential maximum/minimum allowable limits
- CE marking

Valves with a total weight > 1000 kg shall be marked additionally with a permanent information of the weight on the valve or on an safe name- plate.

The provisional KKS-Labels which are fabricated and properly sized are to be made of plastic or similar unbreakable material and attached to the component by wire. The lettering on the labels should include the KKS classification in back, permanent ink.

Marking of the materials for all pressure loaded casing components shall survive during all manufacturing processes according to AD2000-HP 0.

11 Surface Protection

Surface coating of non-stainless steel valves shall be applied as follows

<u>Paint (Coat)</u>	<u>Paint Type</u>	<u>No. of coat</u>	<u>DFT*</u>
Primer Paint	: Epoxy base Zinc rich primer paint	1 Coat	35
Intermediate Paint	: Epoxy TiO2 Pigmented Polyamide Cured Paint	1 Coat	70
Finish (Final) Paint	: Aliphatic Acrylic 2 Pack Polyurethane Finish paint	2 Coats	75

*DFT – Dry Film Thickness (final) in microns

- Shade as per RAL – Grey 9002

12 Documentation

All the documentation for the delivered valve shall remain with the valve manufacturer and shall be stored for at least 10 years. This documentation shall be labelled such as to ensure traceability and allocation to the corresponding valve and shall be marked as belonging to BHEL. The valve manufacturer shall check the documentation with respect to completeness and correctness before shipping the valve. The valve manufacturer shall certify this at the time of the delivery. It is the obligation of the valve manufacturer to hand over a copy of the total documentation to the purchaser on request and free-of-charge.

BHEL expects a documentation of the module/parts including all instructions which are necessary for service, installation and maintenance. Amendments will be requested separately.

In accordance to the Machinery Directive (98/37/EC) and Pressure Equipment Directive (97/23/EC) the following records and logs shall be provided to the purchaser in any case:

- manufactures declaration
- Declaration of conformity
- Material certificates
- Pressure test
- Non-destructive tests

The documentation - also that of the sub suppliers - shall be written in English language and shall contain at least:

- Test certificates of the prematerial (at least inspection certificate 3.1B according to EN 10204)
- Records of all inspections performed by the valve manufacturer or his sub suppliers during manufacturing:
 - Non-destructive inspections of e.g. weld areas or welds
 - Verification of dimensions
 - Pressure and leak tests
 - Functional tests
- Heat treatments performed
- The European Union guidelines and standards which are valid and can be used for the area of application (e.g. PED 97/23/EG, Low-Voltage Guideline 73/23/EWG, etc..) are to be designated in the declaration of conformity according to the remarks and applied quality modules, and shall include all relevant data (see e.g. appendix VII of Guideline 97/23/EG). Risk disclosure and danger analyses in accordance with EN 1050 are to be handed over to BHEL if necessary.
- If materials without European material approval are drawn on for the order (order papers/designs) (e.g. ANSI/ASME materials) appropriate substitute certificates from a designated authority shall be procured and documented accordingly. If the order pertains to a component of a total design group, then all certificates and certification of the component of the highest category of the total design group shall be made available.

13 Final inspection

The purchaser reserves the right to perform final inspections on his ordered parts in the shop of the valve manufacturer, as well as in the shop of his sub suppliers

14 Delivery and Packing

Details regarding delivery are given in the order, however at least following details shall be given together with the delivered parts:

Actualization of standards and instructions

- Purchaser
- Order-no. / project
- Manufacturer commission-no. / works-no.
- Specification
- Number of pieces
- Type / item
- Nominal diameter [DN]
- Maximum allowable pressure [PS]
- Maximum allowable temperature [TS]
- Fluid
- Manufacturer drawing-no.
- Identification-no. of the valve
- Piece weight

Together with the delivery of the valve the valve manufacturer shall hand over a certificate 2.1

according to EN 10204 in English, which confirms that the delivered valve fulfills the requirements given in the order and in this specification. Furthermore the valve manufacturer shall confirm that only materials as listed in the design bill of material have been used and that the documentation is available in his shop in line with Item 12 above and that he has checked the documentation carefully.

Packing of the valve shall be as follows:

- The valve shall be packed and locked that way, that in general case any damage will be prohibited.
- All openings shall be plugged.
- Detail parts respectively components shall be packed individually, however assignment shall be ensured.
- As far as necessary accessory devices for transportation purposes shall be attached to the valve and/or to the packing, e.g. lifting eyes and lifting signs.
- Bearing areas shall be marked, if necessary.

15 Guarantee

The supplier shall guarantee trouble free operation of the equipment for a period of 2 years after installation and commissioning or a period of 3 years from the date of dispatch of equipment whichever is earlier.

If during erection/commissioning and operation at site, any defect in any component is detected, purchaser's / owner's site representative shall prepare the assessment report and a copy of the same shall be forwarded to the supplier. The supplier shall replace / rectify the concerned items free of charge. The supplier, if he so desires, may depute his representative to site at his own cost otherwise the report of purchaser's / owner's site representative shall be binding on the supplier.

16 Spares

The offer of valves shall include the requirement of spares to be made available at the time of erection & commissioning. A separate offer of spares to be required for 3 to 5 years of operation shall also be separately enclosed along with main offer.

17 Special tools & tackles

Any special tools & tackles, required for erection, commissioning and maintenance of valves shall be included in main offer per set of valves.

18 Supplementary Requirements

The valve manufacturer shall send following documents in triplicate written in English language to the purchaser's department for records. Documents listed under a) and c) shall be delivered with the order acknowledgement:

- a) Part drawing showing the function of the valve and the design bill of material
- b) Operating and maintenance instruction
- c) Spare part list

19 Deviations

Any deviation from this purchasing specification has to be reported to the purchaser immediately. Any deviation is accepted only if this has been approved or accepted by the purchaser in writing. In case of any deviation from the specified properties, also if the proof by testing is not required, the purchaser has the right to reject the material.

BERUEHRUNGSLOSER INDUKTIVGEBER

Typ IFL 5-18-1125PK-1952-2

IFL 5-18-1125PK

- : Einbau im Metall
- : Einbaulage
- : Gehäuse
- : Sensortiefe
- : Anzugsmoment
- : Schockfestigkeit
- : Vibrationsfestigkeit
- : Schutzart

- : buendig
- : beliebig
- : Ms-vernickelt
- : Crastin
- : max. 4300 Ncm
- : 30g, 11 ms gem. IEC68-2-27
- : 10 Hz-55 Hz, 1 mm gem. IEC68-2-6
- : IP 67 fuer den Naeherungsschalter
- : IP 54 fuer die Steckverbindung
- : P

Schaltend nach
Elektrischer Anschluss

ueber Steckverbindung Harting HAN 7D mit 0,5mm² Goldkontakten
(Stecker gehoert zum Lieferumfang)

- Messart
- max. Schaltfrequenz
- Nennspannung
- Spannungsbereich
- Restwelligkeit
- Einschaltdauer
- Leertaststrom
- Laststrom
- Verschaltungsschutz
- Uebertast- u. Kurzschlusschutz: ja
- Nennschaltabstand
- Hysterese bei 20 Grad C
- Hysterese bei 110 Grad C
- Wiederholgenauigkeit
bei 20 Grad C
- Wiederholgenauigkeit
bei 110 Grad C
- Temperatur
- Ausgang
- Revisionslose Betriebszeit
- Lieferant

- : induktiv
- : 500 Hz
- : 24 VDC
- : 10-60 VDC
- : -10 %
- : 100 %
- : 4-8 mA
- : -100mA
- : ja
- : 5 mm
- : -0,5 mm (seitliches Anfahren bei 1,5mm Abstand)
- : -1,0 mm (seitliches Anfahren bei 1,5mm Abstand)
- : -0,10 mm (seitliches Anfahren bei 1,5mm Abstand)
- : -0,25 mm (seitliches Anfahren bei 1,5mm Abstand)
- : -25 Grad C bis 110 Grad C
- : Wechsler
- : min. 24.000 h
- : K. A. Schmersal & Co
- : Hoeddinghofe 30
- : 5600 Wuppertal 2

Geräteschlüssel: LGBAD
INSTRUMENTATION KEY:

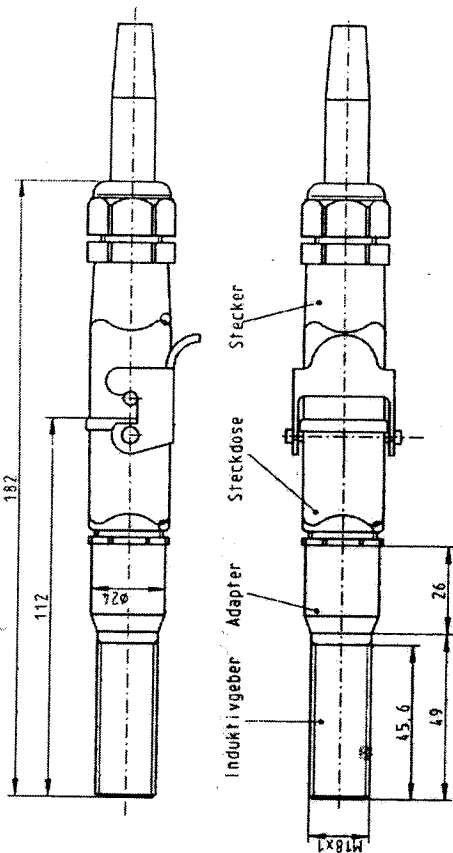

Schaltkurve

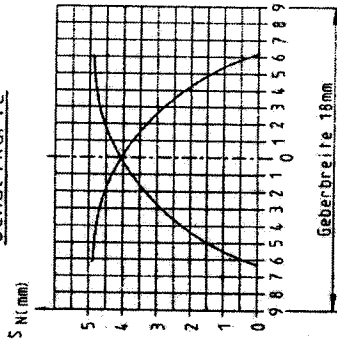

ANSCHLUSSBILD

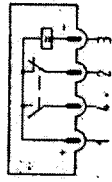

NOTE: 1) Active proximity switch, for taking these wires for termination in J_B, N.C contact not used, R_L refer, sh. 4.

2) FAIL SAFE CONDITION — DE-ENERGISED TO OPEN

TITLE : PROXIMITY SWITCH

BHART HEAVY ELECTRICAL LTD
HARIDWAR, RANIPUR, INDIA-249403

Drawing No. 41810221002 Sh 1

STGRAPH

PROXIMITY SWITCH FOR HPT EVACUATION

Translated version Doc. No. 41810221002

TYP IFL S-18-11zStPK-1952-2

MOUNTING IN METAL:	to be flush in metal
Mounting position:	Any position
Casing:	Ms. Nickel plated
Sensor surface	Crastin
Stud torque	Max 1300 Ncm
Shock reaction	30 gm, 11ms gem. IEC 68-2-27
Resistance to vibration	10Hz 55 Hz, 1mm.
Protection	IP67 for proximity probe
Protection	IP 54 for plug connector
Switching to	.P
Electrical connection	4 wire with Harting HAN 7D plug socket, with 0.5 mm ² gold contact
Mode of measurement	Inductive
Max switching frequency	500Hz
Voltage supply	24V
Supply range	10-6 VDC
Residual ripple	≤ 10%
Running time	100%
Stand by current	≤ 4.8 mA
Running current	≤ 100mA
Non reversible	Yes
Overvoltage protection (short ckt. proof):	Yes
Operating distance	5 mm
Switching hysteresis at 20 Deg	≤ 0.5mm(1.5 mm distance)
Switching hysteresis at 110 Deg	≤ 1.0mm(1.5 mm distance)
Repeat accuracy at 20 Deg	≤ 1.0mm(1.5 mm distance)
Repeat accuracy at 110 Deg	≤ .25mm(1.5 mm distance)
Temp sensor	-25°C to to 110 °C
Output	1 changeover contact with snap action
Inspection time	min 24000 hr
Manufacturer	KA Schemersal & Co Moeddinghofe & co 5600 Wupertal 2

TEST & INSPECTION

- 1.0 Type Test
 - 1.1.0: Degree of protection
- 2.0 Routine Test
 - 2.1.1: Functional and calibration test for limit switch
 - 2.1.2 Fail safe position of actuator
 - 2.1.3 Fully assembly i.e. the valve along with Pneumatic actuator shall be
- 3.0 Tested for proper function.
 - 3.1.0 Test and Guarantee Certificate Results of all tests enumerated in above shall be compiled in test certificate and to be submitted.
- 4.0 Vendor shall provide our inspector or authorized representative all facilities to witness the tests.

LBC41GF051:- X01

1	0	LBC41CG051C
2	0	LBC41CG051C
3	0	LBC41CG051C
4	0	LBC41CG051B
5	0	LBC41CG051B
6	0	LBC41CG051B
7	0	LBC41AA051A
8	0	LBC41AA051A
9	0	LBC41AA051B
10	0	LBC41AA051B
SH	0	SHIELD
SH	0	SHIELD
PE	0	GROUND
PE	0	GROUND

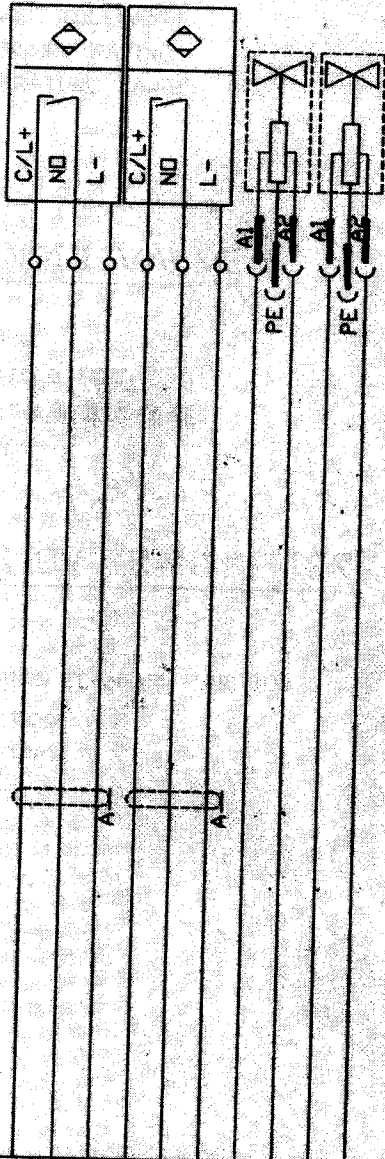

ASSIGNMENT OF CORE CONDUCTOR COLOURS (DINIEC 757)

- BK: BLACK
- BN: BROWN
- BU: BLUE
- GY: GREEN
- GR: GREY
- OR: ORANGE
- PK: PINK
- PU: PURPLE
- RD: RED
- WH: WHITE
- YE: YELLOW

- THE JUNCTION BOX AND THE JUNCTION BOX COVER HAS TO BE LABELLED WITH 'LBC41GF051'
- SHIELD (A), IF AVAILABLE, CONNECTED TO SHIELD TERMINALS (SH)
- GROUND (PE) CONNECTED TO GROUND TERMINALS

REV	REMARKS	TITLE: CONNECTION DIAGRAM HP DUMP VALVE LBC41		SH. NO. 4
		DRAWING NO. 41810221002		BY: /
		BHARAT HEAVY ELECTRICALS LIMITED HARIDWAR		DATE: / /

GENERAL REQUIREMENTS:

VOLTAGE:	24 V DC
VOLTAGE TOLERANCE:	min. +10/-15%
ENCLOSURE RATING:	min. IP65/ NEMA 4
TEMPERATURE RANGE:	+ 5°C TO 70°C (+41°F TO 158°F)

SOLENOID VALVE:

Relative ENERGIZED TIME:	100%
COIL ISOLATION CLASS	CONSTANT RATED
Connection:	F
	plug acc. TO DIN EN 175301-803

POSITION TRANSMITTER:

TYPE:	INDUCTIVE
SWITCHING ELEMENT FUNCTION	PNP NORMAL OPEN
Connection:	3-POLE
Connection:	plug acc. TO DIN EN 175301-803
SHIELD:	NOTREQUIRED BUT WIRED IF AVAILABLE

TITLE: ELECTR. SPEC. SOLENOID/GENERAL
/24DC/INDOOR



BHARAT HEAVY ELECTRICALS LTD
HARIDWAR, RANIPUR, INDIA-249403

DRAWING NO. 41810221002

SH. NO.

5

10 LBC41 AA051

RELATED DRAWINGS:

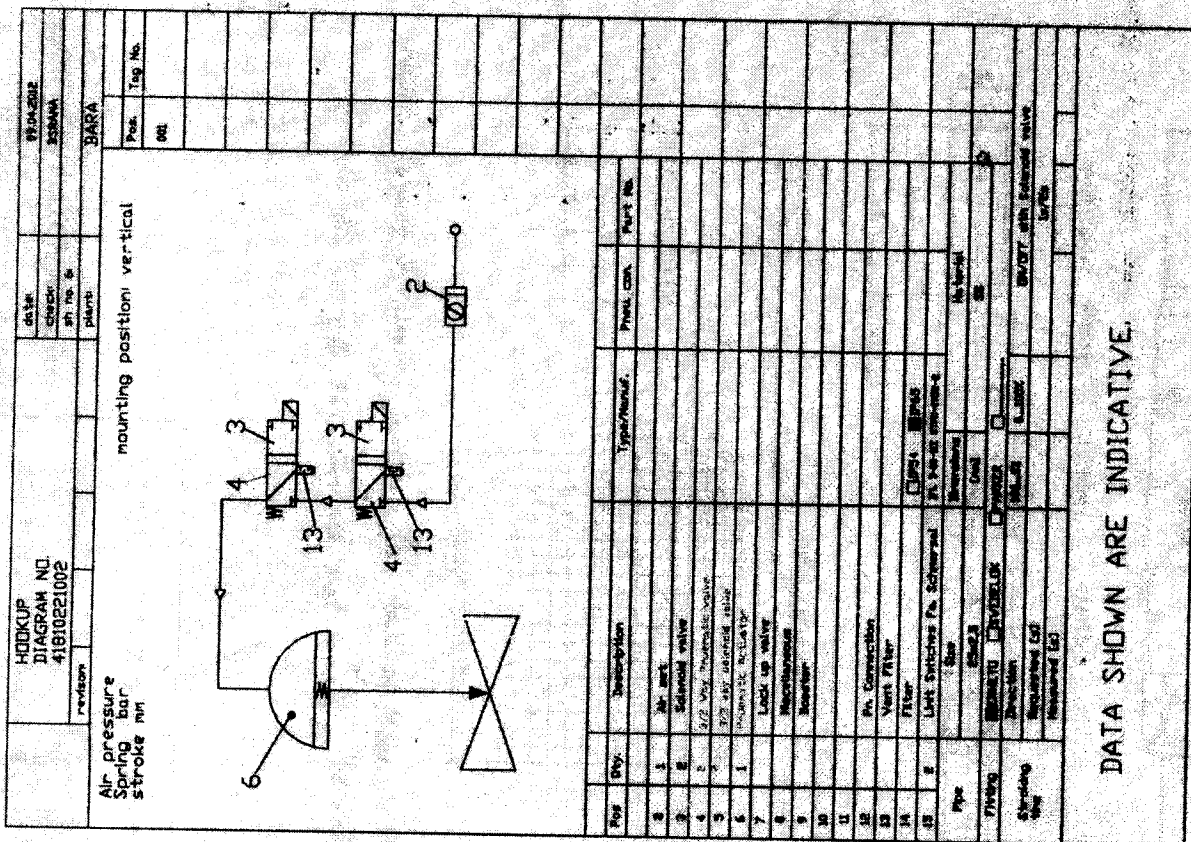

DATA SHOWN ARE INDICATIVE.

MANUFACTURER'S NAME AND ADDRESS		STANDARD QUALITY PLAN				TO BE FILLED BY BHEL			TO BE FILLED BY BHEL			
VENDOR'S NAME		HP RELIEF VALVE		QP NO.	QA BI OP_116							
BHEL		DRG. NO.		DATED								
		AS PER PO		10/02/13								
		SPEC.										
		REV		00		Page 1 of 2						
COMPONENT & OPERATIONS		CHARACTERISTICS		CLASS	TYPE OF CHECK	QUANTUM OF CHECK	REFERENCE DOCUMENT	ACCEPTANCE NORMS	FORMAT OF RECORDS	AGENCY		REMARKS
2		3		4	5	6	7	8	9	M	B	N
1											10	11

1.0- RAW MATERIALS & BOUGHT OUT ITEMS												
Sl. No.	Item	Physical & Chemical Properties	Physical & Chemical Examinations	One per Heat	BHEL, Approved Data Sheet	BHEL, Approved Data Sheet	BHEL, Approved Data Sheet	ASME B 1634 Appendix I	ASME B 1634 Appendix II	BHEL, Approved Data Sheet	Test Certificate	Test Certificate
1.1	Heat Treatment	MA	Verification	One per Heat	BHEL, Approved Data Sheet	BHEL, Approved Data Sheet	BHEL, Approved Data Sheet	ASME B 1634 Appendix I	ASME B 1634 Appendix II	BHEL, Approved Data Sheet	Test Certificate	Test Certificate
1.2	Visual Examination	MA	Visual Examination	100%	BHEL, Approved Data Sheet	BHEL, Approved Data Sheet	BHEL, Approved Data Sheet	ASME B 1634 Appendix I	ASME B 1634 Appendix II	BHEL, Approved Data Sheet	Test Certificate	Test Certificate
1.3	Internal Soundness	CR	Radiograph Test	100% on CA	ASME Sec V	ASME Sec V	ASME Sec V	ASME B 1634 Appendix I	ASME B 1634 Appendix II	BHEL, Approved Data Sheet	Test Certificate	Test Certificate
1.4	Sub surface inspection	CR	Magnetic particle test	100% on Access Area	ASME Sec V	ASME Sec V	ASME Sec V	ASME B 1634 Appendix I	ASME B 1634 Appendix II	BHEL, Approved Data Sheet	Test Certificate	Test Certificate
1.5	Physical & Chemical Properties	MA	Physical & Chemical Examinations	One per Heat	BHEL, Approved Data Sheet	BHEL, Approved Data Sheet	BHEL, Approved Data Sheet	ASME B 1634 Appendix I	ASME B 1634 Appendix II	BHEL, Approved Data Sheet	Test Certificate	Test Certificate
1.6	Trim (Plug Seat Ring & Stem)	MA	Physical & Chemical Examinations	One per Heat	BHEL, Approved Data Sheet	BHEL, Approved Data Sheet	BHEL, Approved Data Sheet	ASME B 1634 Appendix I	ASME B 1634 Appendix II	BHEL, Approved Data Sheet	Test Certificate	Test Certificate
1.7	Prosser Resisting Fasteners	MA	Physical & Chemical Examinations	One per Heat	BHEL, Approved Data Sheet	BHEL, Approved Data Sheet	BHEL, Approved Data Sheet	ASME B 1634 Appendix I	ASME B 1634 Appendix II	BHEL, Approved Data Sheet	Test Certificate	Test Certificate
1.8	Visual Accessories	MA	Visual/Model Verification	100%	BHEL, Approved Data Sheet	BHEL, Approved Data Sheet	BHEL, Approved Data Sheet	ASME B 1634 Appendix I	ASME B 1634 Appendix II	BHEL, Approved Data Sheet	Test Certificate	Test Certificate

2.0- IN PROCESS INSPECTION												
Sl. No.	Item	Physical & Chemical Properties	Physical & Chemical Examinations	One per Heat	BHEL, Approved Data Sheet	BHEL, Approved Data Sheet	BHEL, Approved Data Sheet	ASME B 1634 Appendix I	ASME B 1634 Appendix II	BHEL, Approved Data Sheet	Test Certificate	Test Certificate
2.1	Body, Bonnet, Plug, Seat Rings after machining	MA	Measurement	100%	BHEL, Approved Data Sheet/Drawing	BHEL, Approved Data Sheet/Drawing	BHEL, Approved Data Sheet/Drawing	ASME B 1634 Appendix I	ASME B 1634 Appendix II	BHEL, Approved Data Sheet	IR	IR
2.2	Body & Bonnet	CR	Hydro Test	100%	ASME B 1634/ BHEL, Approved Data Sheet	ASME B 1634/ BHEL, Approved Data Sheet	ASME B 1634/ BHEL, Approved Data Sheet	ASME B 1634 Appendix I	ASME B 1634 Appendix II	BHEL, Approved Data Sheet	IR	IR
2.3	Plug & Seat Contact	MA	Plug & Seat Contact	100%	BHEL, Approved Data Sheet	BHEL, Approved Data Sheet	BHEL, Approved Data Sheet	ASME B 1634 Appendix I	ASME B 1634 Appendix II	BHEL, Approved Data Sheet	IR	IR

MANUFACTURER/SUBCONTRACTOR		FOR CUSTOMER USE		APPROVED BY	
		LEGEND: I RECORDS IDENTIFIED WITH 'TICK' SHALL BE ESSENTIALLY INCLUDED BY CONTRACTOR IN QA DOCUMENTATION. M: MANUFACTURER / SUBCONTRACTOR B: BHEL / NOM. INSPECTION AGENCY N: CUSTOMER INDICATE 'W' PERFORM 'W' WITNESS AND 'V' VERIFICATION ALL 'W' INDICATED IN COLUMN 'N' SHALL BE 'CHP' OF CUSTOMER		 13/01/2015 संजीव कुमार भारद्वाज Sanjeev Kumar Bhardwaj अधिकारी/Engineer गुणता आश्वासन/Quality Assurance बी. एच. ई. एल., हरिकार/BHEL Harikar	

TO BE FILLED BY BHEL

TO BE FILLED BY BHEL

STANDARD QUALITY PLAN

MANUFACTURER'S NAME AND ADDRESS

BHEL	VENDOR'S NAME		ITEM		HP RELIEF VALVE		QA BI QP 116			
	DRG. NO.		QP NO.		DATED		10/02/13			
	SPEC.		AS PER PO							
	REV		AS PER PO							
SL. NO.	COMPONENT & OPERATIONS	CHARACTERISTICS	CLASS	TYPE OF CHECK	QUANTUM OF CHECK	REFERENCE DOCUMENT	ACCEPTANCE NORMS	FORMAT OF RECORDS	AGENCY	REMARKS
1	2	3	4	5	6	7	8	9	M B N	10
										11

Page 2 of 2

3.0- FINAL INSPECTION & TESTING

SL. NO.	DESCRIPTION	TEST	CLASS	TYPE OF CHECK	QUANTUM OF CHECK	REFERENCE DOCUMENT	ACCEPTANCE NORMS	FORMAT OF RECORDS	AGENCY	REMARKS
3.1	Performance Test on Assembled valve fitted with Accessories	Hydro Test	CR	Hydro Test	100%	BHEL, Approved Data Sheet/Drawing	BHEL, Approved Data Sheet/Drawing	Test Certificate	P W	
3.2		Seat Leak Test	CR	Leak Test	100%	BHEL, Approved Data Sheet/Drawing	BHEL, Approved Data Sheet/Drawing	Test Certificate	P W	
3.3		Performance test of Valve	CR	Calibration (hysteresis, Travel, stroke, stroking time)	100%	BHEL, Approved Data Sheet	BHEL, Approved Data Sheet	Test Certificate	P W	
3.4		Packing Tightness	CR	Packing Leak Test	100%	BHEL, Approved Data Sheet	BHEL, Approved Data Sheet	Test Certificate	P W	
3.5		Control Valve Flow Capacity	CR	Capacity Test	One / Type	BHEL Approved Date Sheet/ISA 75.02	BHEL, Approved Full Capacity	Test Certificate	P V	
3.6		Model Verification of Actuator and positioner	MA	Visual	100%	BHEL Approved Date Sheet	BHEL, Approved Data Sheet	Test Certificate	P W	

4.0 PAINTING, PRESERVATION & PACKING

SL. NO.	DESCRIPTION	TEST	CLASS	TYPE OF CHECK	QUANTUM OF CHECK	REFERENCE DOCUMENT	ACCEPTANCE NORMS	FORMAT OF RECORDS	AGENCY	REMARKS
4.1	Final Inspection	Dimension & Visual	MA	Over all Dimension & Visual	100%	App GA Drawing	App GA Drawing	Test Certificate	P W	
4.2	Painting	Paint finish color shade	MA	Visual DFT Measurement	100%	Purchase Specification	Purchase Specification	-	P V	
4.3	Assembled Valve Completeness	Marking/Name Plac & Tagging	MA	Marking/Name Plate & Tagging	100%	BHEL, Approved Data Sheet	BHEL, Approved Data Sheet	-	P W	
4.4	Packing	Packing List, Safety	MA	Verification	100%	Customer Spec	Customer Spec	-	P V	

MANUFACTURER/SUBCONTRACTOR	FOR CUSTOMER USE		LEGEND: I: RECORDS IDENTIFIED WITH 'TICK' SHALL BE ESSENTIALLY INCLUDED BY CONTRACTOR IN QA DOCUMENTATION. M: MANUFACTURER / SUBCONTRACTOR B: BHEL / NOM. INSPECTION AGENCY N: CUSTOMER INDICATE 'P' PERFORM 'W' WITNESS AND 'V' VERIFICATION ALL 'W' INDICATED IN COLUMN 'N' SHALL BE 'CHP' OF CUSTOMER	APPROVED BY: Sanjeev Kumar Bhardwaj अभियंता/Engineer गुणता आश्वासन/Quality Assurance बी. एच. ई. एल., हरियाणा/BHEL, Haryana
	APPROVED BY: Sanjeev Kumar Bhardwaj अभियंता/Engineer गुणता आश्वासन/Quality Assurance बी. एच. ई. एल., हरियाणा/BHEL, Haryana			