

***2x500MW New Neyveli Thermal Power station
UNITS 1&2. NLC Neyveli***

VOLUME – IIB

***TECHNICAL SPECIFICATION FOR
220V DC BATTERY***

BHEL DOCUMENT NO. : PE-TS-402-508-E001, REV-0



**BHARAT HEAVY ELECTRICALS LIMITED
POWER SECTOR
PROJECT ENGINEERING MANAGEMENT
NOIDA – 201301**



**TECHNICAL SPECIFICATION FOR
220V DC BATTERY**

**2x500MW NEW NEYVELI THERMAL POWER
STATION UNITS 1&2, NLC NEYVELI**

SPECIFICATION NO. PE-TS-402-508-E001

VOLUME II B

SECTION -

REVISION 0

SHEET 1 OF 31

CONTENTS

<u>S. NO.</u>	<u>CONTENTS</u>	<u>NO. OF SHEETS</u>
01	INSTRUCTIONS TO BIDDERS	01
02	DEVIATION SCHEDULE	01
03	PREAMBLE	01
04	SECTION – 'A' SCOPE OF ENQUIRY	01
05	SECTION – 'B' PROJECT INFORMATION	03
06	SECTION – 'C' SPECIFIC TECHNICAL REQUIREMENT	08
	ANNEXURE-I BOQ-cum-PRICE SCHEDULE	01
	ANNEXURE-II LIST OF APPLICABLE STANDARDS	01
	ANNEXURE-III LOAD DUTY CYCLE FOR 220V DC SYSTEM	02
	ANNEXURE-IV ONE LINE DIAGRAM FOR 220V DC SYSTEM	01
	ANNEXURE-V ACCESSORIES	02
	ANNEXURE-VI LIST OF STANDARD DELIVERABLES	01
	ANNEXURE-VII NO. OF DRGS / DOCS REQUIRED	01
07	DATASHEET-'A' DC BATTERY	01
08	DATASHEET-'C' DC BATTERY	02
09	QUALITY PLAN	04

TOTAL NO. OF SHEETS = 32 (INCLUDING COVER/ SEPARATOR SHEETS)

(REFER INSTRUCTION NO. 1 OF 'INSTRUCTIONS TO BIDDERS')

**IT IS CONFIRMED THAT OUR TECHNICAL OFFER COMPLIES WITH THE SPECIFICATION IN TOTO, & THAT
THERE ARE NO TECHNICAL DEVIATIONS.**

BIDDER'S STAMP & SIGNATURE



**TECHNICAL SPECIFICATION FOR
220V DC BATTERY**

**2x500MW NEW NEYVELI THERMAL POWER
STATION UNITS 1&2, NLC NEYVELI**

SPECIFICATION NO. PE-TS-402-508-E001

VOLUME II B

SECTION -

REVISION 0

SHEET 2 OF 31

INSTRUCTIONS TO BIDDERS FOR PREPARING TECHNICAL OFFERS

1. In line with clause no. 10.1 of Section-C, Volume-II-B of the specification, two signed and stamped copies of the following shall be furnished by all bidders as technical offer:
 - a. Battery sizing calculation with respect to load duty cycle as per Annexure-III of Section-C to be provided along with supporting documents (capability / discharge curve, temperature correction factor, float charging factor & published technical catalogue) for considered factors.
 - b. Unpriced Price Schedule ("Annexure-I: BOQ cum Price Schedule", as enclosed with the specification) with bidder's signature and company stamp.
 - c. A copy of this sheet ("Instructions to Bidders for Preparing Technical Offer"), with bidder's signature and company stamp.
 - d. A copy of previous sheet ("List of Contents"), with bidder's signature and company stamp.
 - e. A copy of next sheet ("Deviation Schedule"), with "NO DEVIATION" and bidder's signature and company stamp.
 - f. A copy of sheet ("Data Sheet-A"), with required information and bidder's signature and company stamp.
2. No technical submittal except as stated above, such as copies of type test certificates, data Sheets, write-up, drawing, technical literature, etc. is required during tender stage. Any such submission, even if made, shall not be considered as part of offer.
3. Confirmations/ comments (if any) regarding delivery schedules shall be furnished as part of the commercial offer. Any reference elsewhere/ covering letter of technical offer shall not be considered by BHEL.
4. Any comments/ clarifications on technical/ inspection requirements furnished as part of bidder's covering letter shall not be considered by BHEL, and bidder's offer shall be construed to be in conformance with the specification.
5. Any changes made by the bidder in the price schedule with respect to the battery description/ quantities, notes etc. from those given in Annexure-I: BOQ cum Price Schedule shall not be considered (i.e., technical description, quantities, notes etc. as per specification shall prevail).
6. Bidder to note that wherever IS is mentioned equivalent IEC is also acceptable. In case of any technical requirement not covered by IEC, technical requirement as per IS shall prevail.
7. Deviations, if any should be brought out very clearly on deviation schedule enclosed with specification only. Otherwise it will be presumed that the bidder's offer is in line with what has been stated / asked for in this specification.

BIDDER'S STAMP & SIGNATURE



**TECHNICAL SPECIFICATION FOR
220V DC BATTERY**

**2x500MW NEW NEYVELI THERMAL POWER
STATION UNITS 1&2, NLC NEYVELI**

SPECIFICATION NO. PE-TS-402-508-E001

VOLUME II B

SECTION -

REVISION 0

SHEET 3 OF 31

DEVIATION SCHEDULE

SL. NO.	CLAUSE NO.	DEVIATION	REASONS FOR DEVIATION

It is certified that the offer is fully in conformance to the specification requirements except for the deviations, which are specifically brought out in the above prescribed Deviation Schedule.

Signature & seal of Bidder's authorized representative



**TECHNICAL SPECIFICATION FOR
220V DC BATTERY**

**2x500MW NEW NEYVELI THERMAL POWER
STATION UNITS 1&2, NLC NEYVELI**

SPECIFICATION NO. PE-TS-402-508-E001

VOLUME II B

SECTION -

REVISION 0

SHEET 4 OF 31

PREAMBLE

1.0 The Tender documents contains three (3) volumes. The bidder shall meet the requirements of all three volumes.

1.1 **VOLUME - I** **CONDITIONS OF CONTRACT**

This consists of four parts as below:-

Volume – IA This part contains Instructions to bidders for making bids to BHEL.

Volume – IB This part contains General Commercial Conditions of the Tender & includes provision that vender shall be responsible for the quality of item supplied by their sub-vendors.

Volume – IC This part contains Special Conditions of Contract.

Volume – ID This part contains Commercial conditions for Erection & Commissioning site work, as applicable.

1.2 **VOLUME – II** **TECHNICAL SPECIFICATION**

Technical requirements are stipulated in Volume – II, which comprises of:-

Volume – IIA General Technical Conditions.

Volume – IIB Technical Specification including Drawings, if any.

1.3 **VOLUME – IIB**

This volume is sub-divided in to following sections:-

Section – A This section outlines the Intent of Specification

Section – B This section provides “Project Information”.

Section – C This section indicates Technical Requirements specific to Contract.

Data sheet - A :- Specific data and other requirements pertaining to the equipments.

Data sheet – C :- Indicates data / documents to be furnished after the award of Contract as per agreed schedule by the vendor (as applicable)

Quality Plan



**TECHNICAL SPECIFICATION FOR
220V DC BATTERY**

**2x500MW NEW NEYVELI THERMAL POWER
STATION UNITS 1&2, NLC NEYVELI**

SPECIFICATION NO. PE-TS-402-508-E001

VOLUME II B

SECTION -

REVISION 0

SHEET 5 OF 31

SECTION - A

SCOPE OF ENQUIRY

- 1.0 This specification covers the design, manufacture, inspection and testing at manufacturer's works, proper packing and delivery to site of 220V DC Battery as mentioned in different sections of this specification for 2x500MW NEW NEYVELI THERMAL POWER STATION UNITS 1&2, NLC NEYVELI.
- 2.0 It is not the intent to specify herein all the details of design & manufacture. However, the equipment shall conform in all respects to high standards of design engineering and workmanship and shall be capable of performing in continuous commercial operation up to bidder's guarantee.
- 3.0 The general terms and conditions, instructions to bidders and other attachment referred to elsewhere are hereby made part of the Technical Specification.
- 4.0 The bidders shall be responsible for and governed by all requirements stipulated hereinafter.
- 5.0 Bidders shall confirm total compliance to the specification without any deviations from the technical/ quality assurance requirements stipulated.
- 6.0 The documents shall be in English language and MKS system of units.



**TECHNICAL SPECIFICATION FOR
220V DC BATTERY**

**2x500MW NEW NEYVELI THERMAL POWER
STATION UNITS 1&2, NLC NEYVELI**

SPECIFICATION NO. PE-TS-402-508-E001

VOLUME II B

SECTION -

REVISION 0

SHEET 6 OF 31

**SECTION-B
PROJECT INFORMATION**



**TECHNICAL SPECIFICATION FOR
220V DC BATTERY**

SPECIFICATION NO. PE-TS-402-508-E001

VOLUME II B

SECTION -

**2x500MW NEW NEYVELI THERMAL POWER
STATION UNITS 1&2, NLC NEYVELI**

REVISION 0

SHEET 7 OF 31

PROJECT INFORMATION



**2x500 MW, NNTPP, NEYVELI
CONTRACT - I SUPPLIES
STEAM GENERATOR & AUX. PACKAGE - NTA1**



SALIENT FEATURES OF THE SITE & GENERAL PROJECT INFORMATION

1.1 Introduction

The project site at Neyveli has distinct location advantages, being at pit-head distance from the source of lignite supply from Mines, making it convenient for transportation of lignite by belt conveyor. Water source is readily available from the nearby mines lake. Besides, other infrastructure such as access road, railway connection etc, already exist.

1.2 Power Plant Site

The power plant site is located at Neyveli, opposite to the now defunct Fertilizer and Briquetting & Carbonization Plant, near TPS-I Expansion and TPS-II.

1.3 Project & Site Information

- | | | |
|------------------------------------|---|--|
| (i). Owner / Purchaser | : | Neyveli Lignite Corporation Limited (NLC Ltd), Neyveli, Cuddalore District, Tamil Nadu State, India |
| (ii). Consultant | : | Lahmeyer International (India) Pvt. Ltd (LII), Gurgaon, NCR, India. |
| (iii). Project Title | : | 2x500 MW Neyveli New Thermal Power Project (NNTPP) |
| (iv). Location | : | 200 kms south of Chennai and 50 kms south-west of Cuddalore |
| (v). Latitude | : | 11° 34' 00" N to 11° 35' 00" N |
| (vi). Longitude | : | 79° 26' 00" E to 79° 27' 00" E |
| (vii). Elevation above MSL | : | (+) 67 m |
| (viii). Nearest Railway Station | : | Neyveli, |
| (ix). Nearest Sea Port | : | Chennai, at a distance of 200 km |
| (x). Nearest Airport | : | Chennai, at a distance of 200 km |
| (xi). Road Access/Approach to Site | : | Connected by Chennai-Thanjavur NH 45C road and state highway connecting Cuddalore - Virudhachalam via Neyveli. Both NH and state high way roads are well connected to NLC township roads. The approach road is approximately 15 kms from Chennai-Thanjavur NH - 45C road |
| (xii). Site Meteorological Data | : | |
| • Max ambient temperature | : | 42.8° C |
| • Min Ambient Temperature | : | 26.9° C |



CONTRACT - I

VOLUME - I SF & GPI

Page 1 of 2

225





**TECHNICAL SPECIFICATION FOR
220V DC BATTERY**

**2x500MW NEW NEYVELI THERMAL POWER
STATION UNITS 1&2, NLC NEYVELI**

SPECIFICATION NO. PE-TS-402-508-E001

VOLUME II B

SECTION -

REVISION 0

SHEET 8 OF 31



**TECHNICAL SPECIFICATION FOR
220V DC BATTERY**

**2x500MW NEW NEYVELI THERMAL POWER
STATION UNITS 1&2, NLC NEYVELI**

SPECIFICATION NO. PE-TS-402-508-E001

VOLUME II B

SECTION -

REVISION 0

SHEET 9 OF 31

SECTION – ‘C’



**TECHNICAL SPECIFICATION FOR
220V DC BATTERY**

**2x500MW NEW NEYVELI THERMAL POWER
STATION UNITS 1&2, NLC NEYVELI**

SPECIFICATION NO. PE-TS-402-508-E001

VOLUME II B

SECTION -

REVISION 0

SHEET 10 OF 31

SECTION – C

SPECIFIC TECHNICAL REQUIREMENT

1.0 SCOPE OF ENQUIRY

This specification covers the design, manufacture, assembly, testing and inspection at vendor's/sub-vendor's works, packing, despatch to site and supervision of E&C of 220V DC batteries as described in the various sections of this specification. The batteries shall generally conform to IS / IEC. Erection and commissioning is not included in vendor's scope. However Vendor shall still not be absolved of his responsibility of establishing the correctness of equipment at site.

2.0 EQUIPMENT AND SERVICES TO BE FURNISHED BY THE BIDDER

The bidder shall supply the following equipment in accordance with the various sections of this specification. The BOQ cum Price Schedule is enclosed as Annexure-I.

3.0 SERVICES AND EQUIPMENT TO BE EXCLUDED

- A) Civil works like foundation and cable cellar, flooring of the battery room etc.
- B) Ventilation of battery and charger room.
- C) DCDB
- D) Power and control cables
- E) Erection of the equipment
- F) Battery charger, battery fuse box and discharge resistor panel

4.0 CODES AND STANDARDS

Unless otherwise specified, the latest revisions of codes/standards specified in Annexure-II enclosed are applicable and shall be referred to.

5.0 SCHEDULE OF PRICES – BOQ cum Price Schedule for Battery (Annexure-I) Shall Be Considered For Price Evaluation Purpose.

DELIVERY: Ex-works delivery of equipment shall be as per NIT.

6.0 SYSTEM CONCEPT

6.01 220V DC system for each unit shall be an ungrounded system comprising of 2x100% batteries each with individual 2 x 100% float cum boost charger and 1x100% sectionalised DCDB. The 220V DC system is designed to cater the control, protection, and interlocking, emergency DC lighting and emergency DC drives for



**TECHNICAL SPECIFICATION FOR
220V DC BATTERY**

**2x500MW NEW NEYVELI THERMAL POWER
STATION UNITS 1&2, NLC NEYVELI**

SPECIFICATION NO. PE-TS-402-508-E001

VOLUME II B

SECTION -

REVISION 0

SHEET 11 OF 31

complete SG & TG (BTG) package. Each side of DCDB will cater DC load duty cycle requirement as per Annexure-III of Section-C.

- 6.02 Battery and charger will be connected to DCDB as per Annexure-IV. The battery shall be designed to restrict maximum fault level on DCDB limited to 20kA.
- 6.03 In case of failure of AC, battery will meet the DC load requirement. After restoration of power, the float charger will continue to supply the loads as well as trickle charge the battery. Under discharge condition, at a time only one battery will be put to boost charge.
- 6.03 The 220V batteries are sized considering emergency load cycle requirement of 120 minutes and design factors (as per Annexure-III). For lead acid battery, the derating factor for prolong float charging shall be duly taken into account, while estimating the battery capacity.
- 6.04 The voltage at load terminal will not exceed the limits of +10% and -15% of nominal system voltage for 220V DC system.
- 6.05 Batteries shall be connected to DC distribution board through single cores cables copper cable (**1CX630sqmm (Cu)/ pole : Tentative size**) for each pole. Battery terminals shall be made suitable for above cable.
- 6.06 The equipment will be located indoor but in a hot, humid and tropical atmosphere.
- 6.07 Necessary accessories required for maintenance and testing of batteries shall be supplied with each battery bank as per enclosed Annexure-V.

7.0 OTHER TECHNICAL REQUIREMENTS

7.1 Lead-Acid Batteries

- a) Batteries shall be stationery storage Lead Acid Plante high discharge type conforming to IS-1652 / IEC60896-11. The batteries shall meet the 'Load Duty Cycle' requirements under all site-operating conditions as specified.
- b) Containers:
Containers shall be made of clear view SAN type, robust, heat resistant, shock absorbing, leak proof, non-absorbent, acid resistant, non-bulging type and free from flaws such as wrinkles, cracks, blisters, pinholes etc. Electrolyte level lines shall be marked on containers. The marking for the electrolyte level shall be for upper & lower limits. Container shall be SAN container closed/sealed lid type. Open type cells are not acceptable. Lid and sealing compound shall be non-cracking type. The type test report for container made of plastics shall be type tested as per IS-1146



**TECHNICAL SPECIFICATION FOR
220V DC BATTERY**

**2x500MW NEW NEYVELI THERMAL POWER
STATION UNITS 1&2, NLC NEYVELI**

SPECIFICATION NO. PE-TS-402-508-E001

VOLUME II B

SECTION -

REVISION 0

SHEET 12 OF 31

to be submitted. All type tests reports for sealing compound as per IS-3116. The pole sealing arrangement shall be such that no acid particle gets entrapped due to acid creep as a result of capillary action and it shall be possible to remove and refit the sealing to carry out maintenance.

c) Vent Plugs:

Vent plugs shall be provided in each cell. They shall be anti-splash type to prevent explosion and contamination, having more than one exit hole shall allow the gases to escape freely but shall prevent acid from coming out. The design shall be such that the water loss due to evaporation is kept to minimum. In addition the ventilator shall be easily removed from topping up the cells and of such dimensions that the syringe type hydrometer can be inserted into the vent to take electrolyte sample.

d) Plates:

The plates shall be designed for maximum durability during all service conditions including high rate of discharge and rapid fluctuation of load. The construction of plate shall be as per IS-1652 / IEC60896-11.

The separators (made of acid resisting material) shall maintain the electrical insulation between the plates and shall permit free flow of electrolyte. Separators shall be suitable for continuous immersion in the electrolyte without distortion. The positive and negative terminal posts shall be clearly marked. The proper arrangement shall be made inside battery to keep endplates in position. The positive plates shall be supported from the ledges of the SAN container. They should not be supported at the bottom of container. Sufficient space shall allowed to allow the creepage of the plates.

e) Sediment Space:

Sufficient sediment space shall be provided so that cells will not have to be cleaned during normal life and prevent shorts within the cells.

f) Electrolyte:

The electrolyte shall be prepared from battery grade Sulphuric Acid conforming to IS-266 and distilled water conforming to IS-1069. The cells shall be shipped in dry uncharged condition and electrolyte shall be supplied separately in non-returnable containers. 10% extra electrolyte shall be furnished as extra fitting to cover spillage in transit or during erection.

g) Connectors and Fasteners:

Lead or lead coated copper connectors shall be used for connecting up adjacent cells and rows. The cell terminal post shall be provided with bolts, nuts, clamps, connectors and washers shall be lead coated **with minimum thickness 0.025 mm to prevent corrosion**. The thickness of lead coating shall be measured as per appendix-F of IS-6848. All the terminals and inter-cell connectors shall be fully insulated or have insulated shrouds. End take of connections from positive and negative poles of batteries shall be done through single core copper cable having stranded copper conductor and XLPE insulation (1CX630sqmm (Cu)/ pole:



**TECHNICAL SPECIFICATION FOR
220V DC BATTERY**

SPECIFICATION NO. PE-TS-402-508-E001

VOLUME II B

SECTION -

**2x500MW NEW NEYVELI THERMAL POWER
STATION UNITS 1&2, NLC NEYVELI**

REVISION 0

SHEET 13 OF 31

Tentative size). The bidder shall supply lead coated bent copper plate, tubular copper lugs, clamps, bolts, nuts, washers, etc. for termination of these cables on batteries. Suitable numbers of inter rack connectors shall be supplied by the bidder to suit the battery room layout during detailed engineering. Calculation for sizing of connectors and fasteners shall be furnished during detail engineering.

All connectors and lugs shall be capable of continuously carrying the 2 hour discharge current of respective batteries and through fault short circuit current, which the battery can produce and withstand for the period of one second. The successful bidder shall furnish necessary sizing calculations to prove the compliance for the same at contract stage.

h) Battery Racks:

Wooden racks with anti-corrosive epoxy paint for all the battery shall be provided. These racks shall be made of good quality first class seasoned teak. They shall be free standing type mounted on porcelain / hard rubber / PVC pads insulators. Battery shall preferably be located in the single tier arrangement. However battery having a complete cell weight of lower than 50 Kg could be located in the double tier arrangement. The battery rack and wooden support for cable termination shall be coated with three (3) coats of anti-acid paint of approved shade. Numbering tags, resistant to acid, for each cell shall be attached on to the necessary racks. The bottom tier of the stand shall not be less than 150 mm above the floor. Wherever racks are transported in dismantled condition, suitable match markings shall be provided to facilitate easy assembly. The nameplates, resistant to acid, for each cell shall be attached on the necessary racks.

i) Following information shall be indelibly marked on outside of each cell:

- Manufacturer's name and trade marks
- Country and year of manufacturer
- Manufacturer type designation
- AH capacity at 10 hour discharge rate
- Serial number

j) Positive and negative terminal posts shall be clearly and indelibly marked for easy identification. Numbering tags for each cell shall also be attached on to the racks.

k) Following minimum information shall be given on the instruction cards:

- Manufacturer's instructions for filling and initial charging of the battery together with starting and finishing charging rate
- Maintenance instructions
- Designation of cell in accordance with relevant standard
- Storing conditions of electrolyte

8.0 PERFORMANCE GUARANTEE

8.1 Bidders shall guarantee that battery offered shall meet the 'Load Duty Cycle' and information given in annexure –III requirements as stipulated in this specification



**TECHNICAL SPECIFICATION FOR
220V DC BATTERY**

**2x500MW NEW NEYVELI THERMAL POWER
STATION UNITS 1&2, NLC NEYVELI**

SPECIFICATION NO. PE-TS-402-508-E001

VOLUME II B

SECTION -

REVISION 0

SHEET 14 OF 31

and as confirmed by them in technical data sheets. In case the performance of battery at site is not as per the performance guarantee, the bidder will have to replace the battery at site free of cost.

9.0 INSPECTIONS & TESTING

9.1 Offered equipment shall be of type test design. The bidder shall confirm compliance to quality plan enclosed with the specification, which is subject to BHEL & NLC approval and the inspection shall be carried out based on this approved Quality Plan (QP No. PE-QP-999-508-E002, Rev. 00).

9.2 All acceptance and routine tests as per relevant standards and as per QP (attached) shall be carried out by the manufacturer. Charges for all these routine and acceptance tests for all the materials shall be deemed to be included in the bid price.

9.3 Following type tests as per IS-1652 / IEC60896-11 to be conducted on two cells of the each battery
a. Capacity test and test for battery voltage during discharge.
b. Ampere hour & watt hour efficiency test.

9.4 The Capacity test and test for voltage on battery during discharge shall be carried out at site on completion of E&C and immediately prior to putting battery in service. Necessary testing equipment required for testing at site (including site visit) shall be arranged by bidder.

9.5 For all components / materials, for which type test reports have been asked as per relevant standard, such Type tests should have been carried out on identical components / materials. In absence of such type tests reports or in case such reports are not found to be meeting the specification/standards requirements, vendor shall conduct all such type tests without any commercial/delivery implication to BHEL according to the relevant standards and reports shall be submitted to the owner for approval. (Type test charges as per clause 9.6 shall not be applicable in such cases).

9.6 The bidder shall indicate cost of carrying out all the Type tests as specified in clause 9.3 of the specification. The charges for each of the Type tests shall be given separately in price schedule.

9.7 All material used for the construction of the equipment / items shall be new and shall be in accordance with the requirements of this specification. Materials utilised shall be those, which have established themselves for use in such applications.

10.0 DOCUMENTATION



**TECHNICAL SPECIFICATION FOR
220V DC BATTERY**

SPECIFICATION NO. PE-TS-402-508-E001

VOLUME II B

SECTION -

**2x500MW NEW NEYVELI THERMAL POWER
STATION UNITS 1&2, NLC NEYVELI**

REVISION 0

SHEET 15 OF 31

10.1 By all Bidders as technical offer:

- (i) Battery sizing calculation (in IEEE format) with respect to load duty cycle as per Annexure-III of Section-C to be provided along with supporting documents (capability / discharge curve, temperature correction factor, float charging factor & published technical catalogue) for considered factors.
- (ii) Unpriced Price Schedule (“Annexure-I: BOQ cum Price Schedule”, as enclosed with the specification) with bidder’s signature and company stamp.
- (iii) A copy of sheet “Instructions to Bidders for Preparing Technical Offer” with bidder’s signature and company stamp.
- (iv) A copy of sheet “List of Contents” with bidder’s signature and company stamp.
- (v) A copy of sheet “Deviation Schedule” with “NO DEVIATION” and bidder’s signature and company stamp.
- (vi) A copy of sheet “Data Sheet-A” with required information and bidder’s signature and company stamp.

10.2 Final documents to be submitted after award of contract shall be as given in Annexure-VI.

10.3 No. of prints to be submitted by vendor after award of contract shall be as specified under Annexure-VII.

10.4 Instruction Manuals

Instruction manuals for the installation, operation and maintenance of battery to be supplied shall be furnished at least two months before the date of despatch of equipment.

The installation and maintenance manual of battery shall contain the following:

- A) General description giving type and rating of various batteries.
- B) Technical data.
- C) Salient constructional details.
- D) Instruction to be followed on receipt at site.
- E) Instructions for foundations, if any.
- F) Erection procedures and checks (handling at site, erection, pre-commissioning).
- G) Procedure for filling of electrolyte.
- H) Commissioning procedures and site tests.
- I) Routine, periodic and preventive inspection and maintenance procedures.
- J) Safety rules.
- K) Possible faults, their causes and remedies.
- L) Copies of the type, acceptance and routine test certificates in bound volume.



**TECHNICAL SPECIFICATION FOR
220V DC BATTERY**

**2x500MW NEW NEYVELI THERMAL POWER
STATION UNITS 1&2, NLC NEYVELI**

SPECIFICATION NO. PE-TS-402-508-E001

VOLUME II B

SECTION -

REVISION 0

SHEET 16 OF 31

- M) Catalogues, literature and drawings.
- N) Outline dimension drawings showing constructional features, relevant cross sectional views and earthing details, operator oriented description of equipment and accessories.
- O) Operating procedures, maintenance procedures & precautions to be taken during operation and maintenance work.

10.5 Bidder shall furnish field quality plan detailing out the specific quality control procedure covering receipt of material/equipment and handling at site, storage, erection, commissioning, post commissioning etc.

11.0 TOOLS AND TACKLE

Tools & tackle which are essential to facilitate assembly, adjustments, maintenance & dismantling of equipment shall be provided as part of equipment supplied. The above tools shall be supplied along with the initial consignment of equipment so as to be available prior to erection but may not be used for erection purposes.

12.0 BASIC DESIGN DOCUMENTS

'Basic Design Documents' cover: Battery sizing calculations, battery data sheet, connector sizing calculation, Quality Plan, OGA for 220V battery, BOM, List of approved makes, type test reports & type test procedure (if applicable) for battery.

13.0 AS-BUILT DRAWINGS

Though only supply of equipment is under bidder's scope, bidder may note that all as-built correction (as given by purchaser to vendor) shall have to be incorporated in the originals by the vendor and copies of the as-built corrected drawings / documents as per requirement shall be submitted by the vendor.

14.0 Statutory and regulatory requirements as per IE rule 1956 with amendment - 3 rule 1986, rules Nos. 35, 42, 50 & 51 shall be adhered to.

**2x500MW NEW NEYVELI THERMAL POWER STATION UNITS 1&2, NLC NEYVELI
'BOQ-cum-PRICE SCHEDULE FOR 220V DC BATTERY**

**'ANNEXURE-I'
'SPECIFICATION NO. PE-TS-402-508-E001**

Sr. No.	Item code	Item Description	Unit	Quantity	Unit Price	Total price	Remarks
(A)	MAIN ITEMS						
1.0	508-11013-A	LEAD ACID PLANTE 220V UNIT BATTERY	Nos.				220V DC, AH capacity to be decided by bidder as per Annexure-III (UNIT BATTERY) of Section-C, 1.85 ECV, 110 cells, Lead-Acid Plante high discharge battery with 100% electrolyte +10% extra electrolyte, all accessories listed at 1.1, suitable cable termination arrangement and wooden rack properly treated for anti sulphuric acid resistance coated with 3 coats of anti-acid plant.
		Break-up of 1.0					
1.a		220V DC, AH capacity to be decided by bidder as per Annexure-III (UNIT BATTERY) of Section-C, 1.85 ECV, 110 cells, Lead-Acid Plante high discharge battery	Set	4			
1.b		100% Electrolyte (sulphuric acid) for first filling with 10% extra for 220V battery bank	Lot	4			
1.c		Wooden (Teakwood) racks for battery properly treated for anti sulphuric acid resistance coated with 3 coats of anti-acid paint for 220V battery bank	Lot	4			
1.d		Stand insulators plus 5% extra	Lot	4			
1.e		Cell inter-connectors with 5% extra and end take-off with one no. extra	Lot	4			
1.f		Lead coated connection hardware plus 5% extra	Lot	4			
1.g		Cell numbering tags with fixing arrangement (1 set)	Lot	4			
1.h		Teak wood clamps with hardware (1 set)	Lot	4			
1.i		Six extra cell with all accessories without acid	Lot	4			Total Nos=24 cells
1.1		LIST OF ACCESSORIES WITH EACH BATTERY SET					
1.1.1		Inter-connector bolt wrench	No.	1			
1.1.2		Hydrometer to measure specific gravity (in step of 0.005)	No.	1			
1.1.3		Set of hydrometer syringes (suitable for the vent holes in different cells)	SET	1			
1.1.4		Specific gravity correction chart	Nos.	1			
1.1.5		Thermometer with plug & cap, specific gravity correction scale	No.	1			
1.1.6		Digital Cell testing voltmeter (3-0-3V)	No.	1			
1.1.7		Acid resisting funnel	Set	2			
1.1.8		Acid resisting jug of adequate capacity	Set	1			
1.1.9		Rubber apron	Set	1			Part of item 1.0
1.1.10		Pair of rubber hand gloves	set	1			
1.1.11		Set of spanners for cells	set	1			
1.1.12		Cell lifting straps	set	1			
1.1.13		'No smoking' notice	Nos.	2			
1.1.14		Bridging clamps	Set	1			
1.1.15		Goggles (industrial)	Nos.	2			
1.1.16		Instruction card	Nos.	10			
1.1.17		First aid box	Nos.	1			
1.1.18		PVC spill trays under battery set	Nos.	1			
1.1.19		Battery log book	Nos.	1			
2.0	508-11022-A	MANDATORY SPARES					
2.1		Stand insulators	Nos	50			
2.2		Connectors with Nuts and Bolts	Nos	50			
3.0	508-11007-A	E & C SPARES	Set	1			
3.1		Intercell connector	Nos.	90			
3.2		Vent plug	Nos.	50			
3.3		Gloves	Set	2			
4.0	508-11029-A	TYPE TEST	Lot	1			Type test on Two cells of Battery
4.1		Test for capacity & test for voltage during discharge	Lot	1			
4.2		Ampere hour & watt hour efficiency test	Lot	1			
5.0	508-11025-A	SUPV. OF E&C	Set	2			1 Set refers to 1 No. Unit

Notes:

- 1) Cable Lugs at battery terminals shall be in bidder's scope & cable sizes shall be informed during detailed engineering.



**TECHNICAL SPECIFICATION FOR
220V DC BATTERY**

**2x500MW NEW NEYVELI THERMAL POWER
STATION UNITS 1&2, NLC NEYVELI**

SPECIFICATION NO. PE-TS-402-508-E001

VOLUME II B

SECTION -

REVISION 0

SHEET 17 OF 31

ANNEXURE-II

LIST OF APPLICABLE STANDARDS

- | | | |
|-----|---|-------------|
| 1. | STATIONERY LEAD ACID PLANTE BATTERY | IS 1652 |
| 2. | RECOMMENDED PRACTICE FOR SIZING LEAD ACID BATTERIES | IEEE 485 |
| 3. | SPECIFICATION FOR WATER FOR STORAGE BATTERIES | IS 1069 |
| 4. | SPECIFICATION FOR SULPHURIC ACID FOR LEAD ACID BATTERIES | IS 266 |
| 5. | RUBBER & PLASTIC CONTAINERS FOR LEAD ACID BATTERIES | IS 1146 |
| 6. | SYNTHETIC SEPARATORS FOR LEAD ACID BATTERIES | IS 6071 |
| 7. | SEALING COMPOUND FOR LEAD ACID BATTERIES | IS 3116 |
| 8. | METHODS OF TESTS FOR LEAD ACID BATTERIES | IS 8320 |
| 9. | SPECIFICATION FOR HIGH PERFORMANCE PLANTE'S CELLS | BS-6290 |
| 10. | ELECTRICAL VOCABULAR, PRIMARY CELLS AND BATTERIES. | IS: 1885 |
| 11. | LEAD-ACID BATTERIES FOR TRAIN LIGHTING & AIRCONDITIONING SERVICES | IS: 6848 |
| 12. | STATIONARY LEAD-ACID BATTERIES – VENTED TYPES – GENERAL REQUIREMENTS & METHODS OF TESTS | IEC60896-11 |
| 13. | INDIAN ELECTRICITY RULES & INDIAN ELECTRICITY ACTS | |

Note:

Vendor to note that wherever IS is mentioned equivalent IEC is also acceptable. In case of any technical requirement not covered by IEC, technical requirement as per IS shall prevail.



**TECHNICAL SPECIFICATION FOR
220V DC BATTERY**

**2x500MW NEW NEYVELI THERMAL POWER
STATION UNITS 1&2, NLC NEYVELI**

SPECIFICATION NO. PE-TS-402-508-E001

VOLUME II B

SECTION -

REVISION 0

SHEET 18 OF 31

ANNEXURE-III

**(a) LOAD DUTY CYCLE FOR 220V DC SYSTEM (FOR UNIT BATTERY)
220V DC SYSTEM**

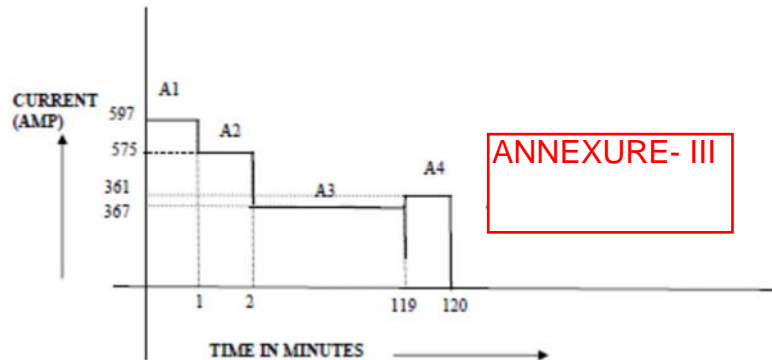

2x500 MW NHTPS
DC LOAD DATA SHEET

		TOTAL EMERGENCY PERIOD 2 HOURS (TABLE-1)							REV02		
SL. No.	LOAD DESCRIPTION	W-S	NAME PLATE RATING	LOAD (A) CONSIDERED	LOAD IN AMPS FOR 0-1 MIN	1-2 MIN	2-119MIN	119-120 MIN	CONT.	REV.	SOURCE
1	UNIT ELECTRICAL CONTROL PANEL	1+1		1.00	1.00	1.00	1.00	1.00	1.00	0	EDN
2	SACP	1+0		1.00	1.00	1.00	1.00	1.00	1.00	0	EDN
3	AVR PANEL	1+1		5.00	5.00	5.00	5.00	5.00	5.00	0	EDN
4	EM. OIL PUMP (TURBINE)	1+0	13.0 kW	97.00	0.00	310.40	97.00	97.00		0	HWR
5	DC SEAL OIL PUMP	1+0	8.5 kW	69.00	220.11	69.00	69.00	69.00		0	HWR
6	ACCOUSTIC ENCLOSURE DC LIGHTING	1+0	5 kW	22.73	22.73	22.73	22.73	22.73	22.73	0	HWR
7	DC LIGHTING			21	21	21	21	21.00		0	PEM
8	ERV CONTROLLER BOX	8+0	0.3 kW	1.40	0.00	0.00	0.00	0.00	0.00	2	TRICHY
9	BMS BPS PANEL	1+0	2kW	10.00	0.00	0.00	0.00	0.00	0.00	2	TRICHY
10	BTS PANEL	1+1		1.00	1.00	0.50	0.50	0.50	0.50	0	BPL
11	11KV SWITCHBOARD TRIP COIL			15.00	15.00	0.00	0.00	0.00		0	BPL
12	11KV BREAKER CLOSING COIL			2.00	0.00	0.00	0.00	2.00		0	BPL
13	3.3KV SWITCHBOARD TRIP COIL			20.00	20.00	0.00	0.00	0.00		0	BPL
14	3.3KV BREAKER CLOSING COIL			2.00	0.00	0.00	0.00	2.00		0	BPL
15	415V SWITCHBOARD TRIP COIL			5.00	5.00	0.00	0.00	0.00		0	CBU
16	415V SWITCHBOARD CLOSING COIL			2.00	0.00	0.00	0.00	2.00		0	CBU
17	GEN. RELAY PANEL	1+1		1.00	1.00	1.00	1.00	1.00	1.00	0	BPL
18	COOLER CONTROL CABINET FOR GT	1+1		0.00	0.00	0.00	0.00	0.00	0.00	2	NTA3
19	COOLER CONTROL CABINET FOR UT-A,B	2+2		0.00	0.00	0.00	0.00	0.00	0.00	2	NTA3
21	COOLER CONTROL CABINET FOR ST	1+1		0.00	0.00	0.00	0.00	0.00	0.00	2	NTA3
22	EM. OIL PUMP (TDBFP)	2+0	11.0 kW	59.00	259.60	118.00	118.00	118.00		0	HYD
23	DC LIGHTS FOR TURBINE ENCLOSURE	2+0	0.5 kW	2.3	4.6	4.6	4.6	4.6	4.6	0	HYD
24	INDICATING LAMP	LOT		5.00	5.00	5.00	5.00	5.00	5.00	0	
25	NUMERICAL RELAY	LOT		5.00	5.00	5.00	5.00	5.00	5.00	0	BPL/CBU
26	MULTIFUNCTION METER	LOT		0.5	0.5	0.5	0.5	0.5	0.5	0	BPL/CBU
27	AUX. RELAY	LOT		9.5	9.5	9.5	9.5	9.5	9.5	0	BPL/CBU
28	DATA CONCENTRATOR -MV	1+1		1.00	0.00	0.00	0.00	0.00	0.00	2	BPL
29	DATA CONCENTRATOR -LV	1+1		1.00	0.00	0.00	0.00	0.00	0.00	2	CBU
TOTAL TG LOAD					596.99	574.18	360.78	366.78	55.78	2	
TG LOAD AFTER ROUNDING OF FOR BATTERY / CHARGER SIZING					597.00	575.00	361.00	367.00	56.00	2	



**TECHNICAL SPECIFICATION FOR
220V DC BATTERY**

**2x500MW NEW NEYVELI THERMAL POWER
STATION UNITS 1&2, NLC NEYVELI**

SPECIFICATION NO. PE-TS-402-508-E001

VOLUME II B

SECTION -

REVISION 0

SHEET 19 OF 31

ANNEXURE-III

FACTORS TO BE CONSIDERED FOR BATTERY SIZING:

- | | |
|----------------------------------|------------------------------|
| 1. AGEING FACTOR | : 1 |
| 2. MIN.ELECTROLYTIC TEMP. | : 15 °C |
| 3. END CELL VOLTAGE | : 1.85V PER CELL |
| 4. DESIGN MARGIN | : 15% |
| 5. ADDITIONAL MARGIN | : 40% |
| 6. TEMPERATURE CORRECTION FACTOR | : As per manufacturer's data |
| 7. MINIMUM RATING OF BATTERY | : 1760Ah AT 27 °C |

PLEASE REFER TO THE FOLLOWING STEPS IN ADDING DESIGN MARGINS

BASE RATING OF THE BATTERY	-	A
TEMPERATURE CORRECTION FACTOR	-	B
DESIGN MARGIN	-	(15%)
ADDITIONAL DESIGN MARGIN	-	(40%)

FINAL RATING = AXBX1.55



**TECHNICAL SPECIFICATION FOR
220V DC BATTERY**

**2x500MW NEW NEYVELI THERMAL POWER
STATION UNITS 1&2, NLC NEYVELI**

SPECIFICATION NO. PE-TS-402-508-E001

VOLUME II B

SECTION -

REVISION 0

SHEET 20 OF 31

ANNEXURE-IV

ONE LINE DIAGRAM FOR 220V UNIT DC SYSTEM

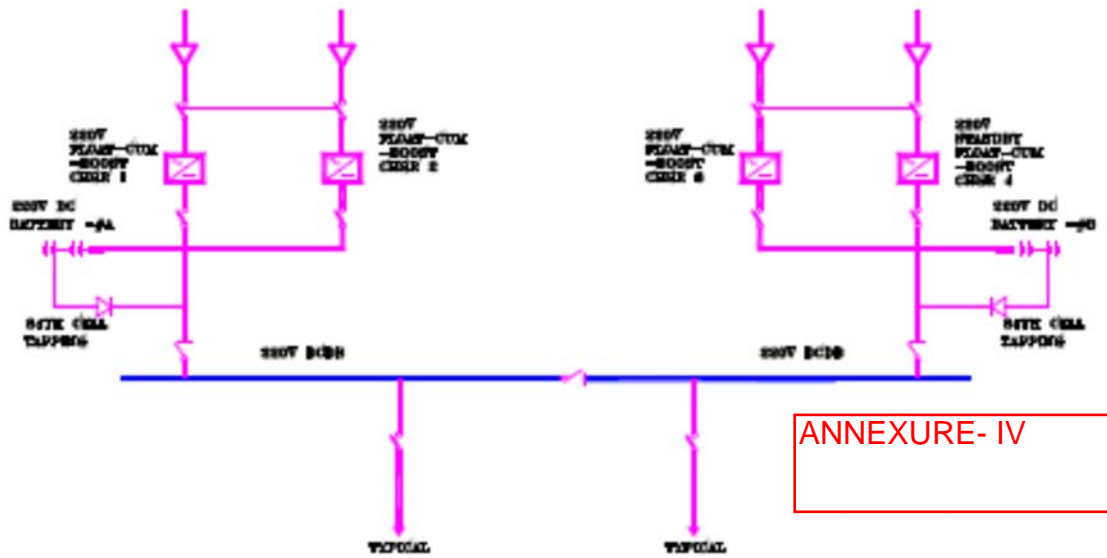



**TECHNICAL SPECIFICATION FOR
220V DC BATTERY**

**2x500MW NEW NEYVELI THERMAL POWER
STATION UNITS 1&2, NLC NEYVELI**

SPECIFICATION NO. PE-TS-402-508-E001

VOLUME II B

SECTION -

REVISION 0

SHEET 21 OF 31

ANNEXURE-V

ACCESSORIES

Following accessories shall be provided for each battery bank:

7.1 Each battery is furnished with following items

Sl. No.	Fittings
1	First charge of electrolyte plus 10% extra
2	Teakwood with 3 coats of anti-acid paint
3	Stand insulators plus 5% extra
4	Cell inter-connectors with 5% extra and end take-off with one no. extra
5	Lead coated connection hardware plus 5% extra
6	Cell numbering tags with fixing arrangement (1 set)
7	Insulated cable clamps with hardware (1 set)
8	Six (6) extra cell with all accessories without acid

7.2 Additionally, following set of accessories shall be provided for each battery:

S no	Name of accessory	QTY (in Nos.)
1	Inter-connector bolt wrench	1
2	Hydrometer to measure specific gravity(in step of 0.005)	1
3	Set of hydrometer syringes (suitable for the vent holes in different cells)	1
4	Specific gravity correction chart	1
5	Thermometer with plug & cap, specific gravity correction scale	1
6	Digital Cell testing voltmeter (3-0-3V) with leads	1
7	Set of Acid resisting funnel	2
8	Set of Acid resisting jug of adequate capacity	1
9	Set of Rubber apron	1
10	Pair of rubber hand gloves' set	1
11	Spanners for cells	1
12	Cell lifting straps	1 set



**TECHNICAL SPECIFICATION FOR
220V DC BATTERY**

**2x500MW NEW NEYVELI THERMAL POWER
STATION UNITS 1&2, NLC NEYVELI**

SPECIFICATION NO. PE-TS-402-508-E001

VOLUME II B

SECTION -

REVISION 0

SHEET 22 OF 31

13	'No smoking' notice	2
14	Bridging clamps	1 Set
15	Goggles (industrial)	2
16	Instruction card	10
17	First aid box	1
18	PVC spill trays under battery cells	1
19	Battery log book	1



**TECHNICAL SPECIFICATION FOR
220V DC BATTERY**

**2x500MW NEW NEYVELI THERMAL POWER
STATION UNITS 1&2, NLC NEYVELI**

SPECIFICATION NO. PE-TS-402-508-E001

VOLUME II B

SECTION -

REVISION 0

SHEET 23 OF 31

ANNEXURE-VI

LIST OF STANDARD DELIVERABLES

S. No.	DOCUMENT TITLE	DWG. / DOCUMENT No.
1	Data Sheet for battery	PE-V0-402-508-E201
2	Battery sizing calculation (Including battery catalogues, curves etc)	PE-V0-402-508-E202
3	Fault calculation & Connector sizing calculation	PE-V0-402-508-E203
4	General Arrangement drawing for Battery	PE-V0-402-508-E204
5	Bill of Material for the battery	PE-V0-402-508-E205
6	List of Mandatory Spares for battery	PE-V0-402-508-E206
7	O & M manual for battery	PE-V0-402-508-E207
8	Field Quality Plan for battery	PE-V0-402-508-E208
9	Type test reports for the battery	PE-V0-402-508-E209
10	Cable Termination arrangement for battery terminal	PE-V0-402-508-E210
11	Quality Plan for battery	PE-QP-999-508-E002
12	Loose items to be shipped with battery	PE-V0-402-508-E211
13	Packing list (to be submitted after dispatch of battery)	PE-V0-402-508-E212



**TECHNICAL SPECIFICATION FOR
220V DC BATTERY**

SPECIFICATION NO. PE-TS-402-508-E001

VOLUME II B

SECTION -

**2x500MW NEW NEYVELI THERMAL POWER
STATION UNITS 1&2, NLC NEYVELI**

REVISION 0

SHEET 24 OF 31

ANNEXURE-VII

DOCUMENTS/ DRAWINGS DISTRIBUTION SCHEDULE

DRAWING/DOCUMENT DISTRIBUTION LIST

All documents & drawings shall be in English and in metric units

SI		LII	NLC (HQ)	NLC-SITE	BHEL SITE	PMG BHEL	PEM/ UNITS/ PSSR	REMARKS
1	Master list of drawings / document (duly indicating schedule of submission)	Soft copy	Soft copy	Soft copy		Soft copy	Soft copy (S)	
2	Drawings / document for Approval/Information (First Submission)	Soft copy + 2 prints	Soft copy + 3 prints	Soft copy + 1 print		Soft copy	Soft copy (S)	
3	Return with comments/approval	Soft copy (S)	Soft copy	Soft copy		Soft copy	Soft copy	
4	Drawings / Documents for approval (second & subsequent submissions till approval)	Soft copy	Soft copy	Soft copy		Soft copy	Soft copy (S)	
5	Drawings / documents for distribution (Approved by NLC, in cat. 1 or Received for Information)	Soft copy + 2 print (HQ+ Site)	Soft copy + 3 prints	Soft copy + 3 prints	Soft copy + 5 prints	Soft copy	Soft copy (S)	
6	Erection Drawings / documents	-	Soft copy + 1 print	Soft copy + 3 prints	Soft copy + 5 prints	Soft copy	Soft copy (S)	
7	As built Drawings / documents	Soft copy + 1 print	Soft copy + 1 print	Soft copy + 3 prints	Soft copy + 5 prints	Soft copy	Soft copy (S)	
8	Operation & Maintenance Manual	-	Soft copy + 1 print	Soft copy + 10 prints	Soft copy + 5 prints	Soft copy	Soft copy (S)	
9	Type Test Certificate	Soft copy	Soft copy + 1 print	Soft copy + 3 prints	Soft copy + 5 prints	Soft copy	Soft copy (S)	

NOTES:

1. The above schedule of submission does not include Docs/Drgs. of quality assurance/inspection and delivery/dispatches. QAP documents to be submitted as per distribution schedule.
2. Date of submitting soft copy is to be taken as date of submission.
3. S – Source for generation of document.



**TECHNICAL SPECIFICATION FOR
220V DC BATTERY**

SPECIFICATION NO. PE-TS-402-508-E001

VOLUME II B

SECTION -

**2x500MW NEW NEYVELI THERMAL POWER
STATION UNITS 1&2, NLC NEYVELI**

REVISION 0

SHEET 25 OF 31

DATASHEET -A

LEAD ACID PLANTE BATTERY

1.	Rated voltage (V)	:	220V DC
2.	Type of Battery	:	Lead Acid Plante high discharge
3.	Design Ambient	:	50°C
4.	Min Electrolyte temp.	:	15°C
5.	Cell Container	:	Transparent SAN
6.	DC System Earthing	:	Unearthed
7.	Conforming to	:	IEEE / IEC / IS standards
8.	No. of cells & End cell voltage	:	110 Nos.; 1.85V
9.	Nominal Float voltage (V)	:	2.25 V/cell
10.	Boost voltage (Maximum) (V)	:	Bidder to furnish the detail along with offer
11.	AH Capacity of battery at temp 'T' (27°C)	:	Bidder to furnish quoted AH capacity and battery sizing calculation along with offer for battery (Min 1760Ah)
12.	Arrangement of batteries on racks	:	Single tier /Double Tier as per IS
13.	Connection from battery to Charger	:	1CX630sqmm (Cu)/ pole (EPR insulated FS cable) (Tentative Size)
14.	Fault current (DC)	:	20 kA (Max)

Notes:

1. Bidder shall furnish following along with offer:

- Battery capability / discharge curve.
- Battery sizing calculation
- Indicate value at sl. No. 10 & 11 above.

2. Bidders stand guarantee that the rating offered at S. No. 11 shall meet 'Load Duty Cycle' taking into factors account for battery sizing **as per Annexure-III of specification.**



**TECHNICAL SPECIFICATION FOR
220V DC BATTERY**

**2x500MW NEW NEYVELI THERMAL POWER
STATION UNITS 1&2, NLC NEYVELI**

SPECIFICATION NO. PE-TS-402-508-E001

VOLUME II B

SECTION -

REVISION 0

SHEET 26 OF 31

DATA SHEET -C

S. No.	PARAMETER	UNIT	VALUE
1.0	Make and Type		
2.0	AH capacity at 27° C and end voltage		
2.1	At 10 Hr discharge rate	AH	
2.2	At 1 Hr discharge rate	AH	
3.0	Battery Discharge current		
3.1	At one minute rate	Amp	
3.2	At 30 minutes rate	Amp	
3.3	At 30 minutes rate at end voltage	Amp	
3.4	At 60 minutes rate	Amp	
3.5	At 60 minutes rate at end voltage	Amp	
4.0	Types of plates		
4.1	Negative plates		
4.2	Positive plates		
5.0	Method of connection between cells		
6.0	Voltage per cell at the end of charge at the finishing rate	V	
7.0	Recommended Trickle charge current	Amp	
8.0	Type and material of separators		
9.0	Material of container		
10.0	Type of container		
11.0	Internal resistance of cells	Ohms	
12.0	Total resistance of connectors	Ohms	
13.0	Insulator Material for		
13.1	Cells		
13.2	Racks		
14.0	Average life	Years	
15.0	Recommended boost charger rating for		
15.1	Charging in 8 hours	Amp	
15.2	Charging in 10 hours	Amp	



**TECHNICAL SPECIFICATION FOR
220V DC BATTERY**

**2x500MW NEW NEYVELI THERMAL POWER
STATION UNITS 1&2, NLC NEYVELI**

SPECIFICATION NO. PE-TS-402-508-E001

VOLUME II B

SECTION -

REVISION 0

SHEET 27 OF 31

S. No.	PARAMETER	UNIT	VALUE
16.0	Allowable ripple content acceptable to battery (r.m.s)	%	
17.0	Hydrogen evaluation		
18.0	Cell designation in accordance with IS: 1651/1652		
19.0	Applicable standard		
20.0	Whether battery performance curve and calculation for capacities enclosed		
21.0	Recommended Maximum period of storage of Electrolyte before first charge		
22.0	Amount and specific gravity of electrolyte per cell required for first filling at 27° C		
23.0	Recommended specific gravity of electrolyte at 27° C		
23.1	When fully charged		
23.2	When fully discharged		
24.0	Container dimensions	(L X B X H)mm	
25.0	Distance between centres of cells when erected	Mm	
26.0	Terminal connectors		
26.1	Type		
26.2	Material		
27.0	Battery Racks		
27.1	Type & Material		
27.2	Outline dimensions	(L X B X H) mm	
27.3	Net weight	Kg	
28.0	Weight per cell	Kg	
28.1	Net dry weight	Kg	
28.2	Net weight with electrolyte	Kg	
29.0	Total shipping weight of one battery unit (without electrolyte)	Kg	
30.0	Taps provided at cell no.		
31.0	Connection from battery to charger (busbar/ cable)		
32.0	Recommended size of (busbar/ cable)		
33.0	Whether backup calculation furnished		
34.0	Cable lugs at battery terminals of suitable size		

		QUALITY PLAN		CUSTOMER : NNTPS			PROJECT: 2x500MW NNTPS , NEVELI		SPECIFICATION NO. PE-TS-402-508-E001			
				BIDDER/ VENDOR :			STANDARD QUALITY PLAN NO.- PE-QP-999-508-E002, REV.0		SPECIFICATION : TS FOR 220V DC BATTERY			
				SYSTEM			ITEM : LEAD ACID BATTERY		DOC. NO.			
SL. NO.	COMPONENT/ OPERATION	CHARACTERISTIC CHECK	CAT.	TYPE/ METHOD OF CHECK	EXTENT OF CHECK	REFERENCE DOCUMENT	ACCEPTANCE NORM	FORMAT OF RECORD	AGENCY			REMARKS
1	2	3	4	5	6	7	8	9	10			11
1.0	RAW MATERIALS & BOUGHT OUT ITEMS											
1.1	(Pure Lead for Pos. plate, Lead Alloy for Neg. plate & Sulphuric acid)	Chemical	MA	Chemical Analysis	Random Sample	IS:1652, IS:266, IS:1069 & MFR's Std.	IS:1652, IS:266, IS:1069 & MFR's Std.	Test Cert.	3/2	-	1	
1.2	SEPARATOR											
a)	Visual	Visual	MA	Visual	Random Sample	IS:1652 & MFR's Std.	IS:1652 & MFR's Std.	Test Cert.	3/2	-	1	
b)	Physical	Physical		Physical	-do-	-do-	-do-	-do-	3/2	-	1	
c)	Chemical	Chemical		Chemical	-do-	(For Synthetic IS : 6071)	(For Synthetic IS : 6071)	-do-	3/2	-	1	
d)	Electrical Resistance Test	Electrical		Electrical	-do-	-do-	-do-	-do-	3/2	-	1	
e)	Acceptance test Dimension, Volume Porosity, Wettability of separator	Test		As per Standard	-do-	-do-	-do-	-do-	3/2	-	1	
1.3	TERMINAL POST											
a)	Dimensional Conformance	Visual	MA	Visual	Random Sample	IS:1652, IS:8320 & MFR's Std.	IS:1652, IS:8320 & MFR's Std.	Test Cert.	3/2	-	1	
b)	Material Conformance	Chemical	CR	Chemical	-do-	-do-	-do-	-do-	3/2	-	1	
c)	Thread size depth & chamfer	Physical	MA	Measurement	-do-	-do-	-do-	-do-	3/2	-	1	
d)	Surface finish & defects	Visual	MA	-do-	100%	-do-	-do-	-do-	3/2	-	1	
e)	Plating Quality	Thickness	CR	-do-	Random Sample	-do-	-do-	-do-	3/2	-	1	
BHEL			PARTICULARS			BIDDER/ VENDOR						
			NAME									
			SIGNATURE									
			DATE						BIDDER'S/ VENDORS COMPANY SEAL			

LEGEND : 1 - BHEL/CUSTOMER 2 - VENDOR 3 - SUB-VENDOR P - PERFORM W - WITNESS V - VERIFICATION

		QUALITY PLAN			CUSTOMER : NNTPS		PROJECT: 2x500MW NNTPS , NEYVELI		SPECIFICATION NO. PE-TS-402-508-E001			
					BIDDER/ VENDOR :		TITLE: 220V DC BATTERY		SPECIFICATION : TS FOR 220V DC BATTERY			
		SHEET 2 OF 3		SYSTEM			ITEM : LEAD ACID BATTERY		DOC. NO.			
SL. NO.	COMPONENT/ OPERATION	CHARACTERISTIC CHECK	CAT.	TYPE/ METHOD OF CHECK	EXTENT OF CHECK	REFERENCE DOCUMENT	ACCEPTANCE NORM	FORMAT OF RECORD	AGENCY			REMARKS
1	2	3	4	5	6	7	8	9	P	W	V	11
1.4	CONNECTOR											
a)	Dimension	Dimension	MA	Measurement	Random Sample	IS:1652, IS:6848 & Appd. Drg./Doc.	IS:1652, IS:6848 & Appd. Drg./Doc.	Test Cert.	3/2	-	1	
b)	Thickness of lead coating	Visual		Visual	-do-	-do-	-do-	-do-	3/2	-	1	
1.5	VENT CAP											
a)	Dimensional Conformance	Dimension	MA	Measurement	-do-	Refer Remarks#	Refer Remarks#	-do-	3/2	-	1	# Vent cap shall be easily removed from topping up the cells and of such dimensions that the syringe type hydrometer can be inserted into vent to take electrolyte sample.
1.6	CONTAINER											
a)	Verification Constructional requirement	Visual	MA	Visual	Sample Plan as per IS:1146	IS:1652, IS:1146, IS:8320	IS:1652, IS:1146, IS:8320	Test Cert.	3/2	-	1	
b)	Verification of Markings	Visual	MA	-do-	-do-	-do-	-do-	-do-	3/2	-	1	
c)	High Voltage Test	Electrical	MA	-do-	-do-	-do-	-do-	-do-	3/2	-	1	
d)	Drops Ball Test	Mechanical	MA	-do-	-do-	-do-	-do-	-do-	3/2	-	1	
e)	Plastic Yield Test	-do-	MA	-do-	-do-	-do-	-do-	-do-	3/2	-	1	
f)	Acid Resistance Test	Chemical	MA	-do-	-do-	-do-	-do-	-do-	3/2	-	1	
g)	Hydraulic thrust endurance test	Physical	MA	-do-	-do-	-do-	-do-	-do-	3/2	-	1	
2.0	FINISHED BATTERY	Routine Test	CR	Elec. & Meas.	100%	IS:1652 & IS:8320	IS:1652 & IS:8320	Test Cert.	3/2	-	1	
3.0	FINAL INSPECTION											
3.1	Type Test #											
a)	Verification Constructional requirement	Visual	MA	Visual	Sample Plan as per IS: 8320	IS:1652	IS:1652	Inspection Report	3/2	1	-	# Conduction of Type Tests from S.No. (d) to (g) shall be as per Annexure-A enclosed.
b)	Verification of Markings	Dimension	MA	Measurement	-do-	-do-	-do-	-do-	3/2	1	-	
c)	Verification of Dimensions	-do-	MA	-do-	-do-	-do-	-do-	-do-	3/2	1	-	
d)	Test for Capacity & Voltage during discharge	Test	CR	As per IS: 1652	-do-	-do-	-do-	-do-	3/2	1	-	
BHEL			PARTICULARS			BIDDER/ VENDOR						
			NAME									
			SIGNATURE									
			DATE									
									BIDDER'S/ VENDORS COMPANY SEAL			

LEGEND : 1 - BHEL/ CUSTOMER 2 - VENDOR 3 - SUB- VENDOR P - PERFORM W - WITNESS V - VERIFICATION



QUALITY PLAN	CUSTOMER : NNTPS	PROJECT: 2x500MW NNTPS , NEVELI	SPECIFICATION NO. PE-TS-402-508-E001
	BIDDER/ VENDOR	TITLE 220V DC BATTERY	SPECIFICATION : TS FOR 220V DC BATTERY
SHEET 3 OF 3		SYSTEM	ITEM : LEAD ACID BATTERY
			DOC. NO.

SL. NO.	COMPONENT/ OPERATION	CHARACTERISTIC CHECK	CAT.	TYPE/ METHOD OF CHECK	EXTENT OF CHECK	REFERENCE DOCUMENT	ACCEPTANCE NORM	FORMAT OF RECORD	AGENCY			REMARKS
									P	W	V	
1	2	3	4	5	6	7	8	9	10			11
e)	AH & WH efficiency Test	-do-	CR	As per IS:1652	Sample Plan as per IS:8320	IS:1652	IS:1652	Inspection Report	3/2	1	-	
f)	*Retension of Charge	-do-	CR	-do-	-do-	-do-	-do-	-do-	-	-	1	
g)	*Endurance Test	-do-	CR	-do-	-do-	-do-	-do-	-do-	-	-	1	
3.2	Acceptance Test											
a)	Verification of Markings	Visual	MA	Visual	Sample Plan as per IS: 8320	IS:1652	IS:1652	Inspection Report	3/2	1	-	
b)	Verification of Dimensions	Dimension	MA	Measurement	-do-	-do-	-do-	-do-	3/2	1	-	
c)	Test for Capacity	Capacity	CR	As per IS: 1652	-do-	-do-	-do-	-do-	3/2	1	-	
d)	Test for Voltage during discharge	Voltage during discharge	CR	-do-	-do-	-do-	-do-	-do-	3/2	1	-	
4.0	ACCESSORIES	Visual & Dimension	MA	Visual	100%	Appd. Drg./Doc.	Appd. Drg./Doc.	-do-	2	1	-	
5.0	CABLE LUGS	Visual	MA	Visual	100%	Appd. DataSheet	Appd. DataSheet	-do-	2	1	-	

NOTE:- Wherever IS is mentioned equivalent IEC is also acceptable. In case of any technical requirement not covered by IEC, technical requirement as per IS shall prevail.
*Type test report of identical battery to be submitted.

BHEL	PARTICULARS	BIDDER/ VENDOR	
	NAME		
	SIGNATURE		
	DATE		
			BIDDER'S/ VENDORS COMPANY SEAL

LEGEND : 1 - BHEL/ CUSTOMER 2 - VENDOR 3 - SUB- VENDOR P - PERFORM W - WITNESS V - VERIFICATION