



BHARAT HEAVY ELECTRICALS LIMITED

TRANSMISSION PROJECTS ENGINEERING MANAGEMENT

| | | | | | | |
|---------------------------------------|---|----------|----|----------|--------------------|--------------------|
| DOCUMENT No. | TB-376-510-010 | Rev. No. | 00 | Prepared | Checked | Approved |
| TYPE OF DOC. | TECHNICAL SPECIFICATION | | | NAME | AA | VK |
| TITLE SUBSTATION AUTOMATION SYSTEM | | | | SIGN | <i>[Signature]</i> | <i>[Signature]</i> |
| | | | | DATE | 23/4/15 | 22/04 |
| | | | | GROUP | TBEM | W.O. No |
| CUSTOMER | UPPTCL | | | | | |
| CONSULTANT | Power Grid Corporation of India Ltd. | | | | | |
| PROJECTS | 765kV/400kV Agra UPPTCL(New) Substation associated with transmission system for evacuation of power from Lalitpur TPP | | | | | |

[Signature] *[Signature]* *[Signature]*
 23/4/15 22/04 23/4/15
 TBEM W.O. No 84006

CONTENTS

| Section | Description | No. of Sheets |
|---------|--|--------------------|
| 1. | SCOPE, SPECIFIC TECHNICAL REQUIREMENTS & BILL OF QUANTITIES , ANNEXURE I | 9 |
| 2. | DETAILED TECHNICAL REQUIREMENTS – A) EQUIPMENT SPECIFICATION B) ANNEXURE-A C) ANNEXURE-B D) ANNEXURE-C | 46 74 3 3 |
| 3. | PROJECT DETAILS AND GENERAL SPECIFICATION | 27 |
| 4. | SCHEDULE OF GUARANTEED TECHNICAL PARTICULARS | 11 |

COPYRIGHT AND CONFIDENTIALITY
The information on this document is the property of BHARAT HEAVY ELECTRICALS LTD. It must not be used directly or indirectly in anyway detrimental to the interest of the company

| | | | | | | | | |
|---------|------|---------|---------|--------------|------------------|------|------|------|
| Rev No. | Date | Altered | Checked | Approved | REVISION DETAILS | | | |
| | | | | Distribution | TBMM | TBQM | TBCM | TBTS |
| | | | | Copies | 2 | - | - | - |

SECTION I **SCOPE, SPECIFIC TECHNICAL REQUIREMENTS AND QUANTITIES**

1.0 SCOPE

This technical specification covers the requirements of design, manufacture and assembly, testing at manufacturer's works, packing and dispatch of 765kV and 400kV Substation automation System at Agra Substation complete with accessories as listed in BOQ below. Testing and Commissioning of all SAS equipments including Protective relays shall be done by the OEM Engineer along with on-site local training to UPPTCL engineers as specified in respective sections.

The fitments offered shall be of PGCIL approved make or its subsequent approval from PGCIL shall be bidder's responsibility, with no commercial or delivery implications to BHEL. If any of the make offered by the bidder is not acceptable to M/s PGCIL/UPPTCL, the bidder has to supply alternate PGCIL approved make, meeting the specification, with no commercial or delivery implications to BHEL.

All auxiliary relays, timers, counters, aux CTs, switches etc required for completeness of the scheme & good engineering are deemed to be included in the offer and no claim whatsoever shall be entertained at contract stage.

In case of any conflict between the technical details mentioned in this section and the remaining sections of this document, then Section-1 shall prevail and is to be considered as binding requirement.

1.1 The equipment is required for the following Project.

Name of Costumer : UPPTCL

Name of Consultant : Power Grid Corporation of India Ltd

Name of the Project : 765/400KV Agra (UPPTCL) Substation associated with transmission system for evacuation of Power from Lalitpur TPP under consultancy services to UPPTCL.

Refer Section - 3 for Project Details and General Specifications.

2.0 SPECIFIC TECHNICAL PARTICULARS

- a) Complete Substation automation including hardware and software along with associated equipments for following bays (bay as defined in Section II Annexure A – Substation Automation System):
 - 765kV – 09 Nos.
 - 400kV - 15Nos.
 - Necessary BCUs for monitoring and control of Substation auxiliary system.Switchyard Panel rooms considered are as below-
765kV Bays - 3 Nos
400kV Bays – 5 Nos
- i) Integration of IEC61850 communication based monitoring equipments like Online dissolved gas analyser , Optical temperature sensor provided on each 765kV Transformer 1Phase unit , 765kV Shunt reactor 1-Phase unit and 420kV 3 Phase Bus Reactor Unit in SAS is included in bidders scope.

ii) Fixed series compensation (Not in scope of supply of bidder) is considered for 765kV Lines , Lalitpur-I , II . Control & Protection of the FSC system is not in bidders scope. However, the FSC signals shall be made available at FSC SAS Gateway by the FSC Package contractor and integration of those FSC Signals in Substation SAS is included in scope of bidder. The necessary coordination with the FSC vendor regarding the exchange of technical information in this respect, for smooth execution of the project is in bidder's scope.

b) The protection to be provided on 400kV D/c Agra-Agra(South) Line shall be as under –

Main-I Protection : Distance Protection Scheme as per Specification clause No.18.8 of Section –II of the Technical Specification.

Main-II Protection : Current Differential Protection . as per Specification Annexure –B of Section-II .

The scope also covers providing a matching Line Current differential relay (With Built-in distance function as back-up) at the 400kV Agra (South) Substation which shall be fitted in the relay panel provided there under a separate contract.

Remote end Line differential relays shall be supplied as loose at the 400kV Agra(South) UPPTCL S/s . The installation and integration with remote panels is not in bidders scope.

The necessary fibre optic cable to connect the current differential relay with the already laid fibre in the substation under a different contract is also in bidders scope at both ends of D/C Agra-Agra(South) line.

Please note:

The distance protection relays to be supplied for 765kV & 400kV Lines should have feature of Load encroachment blinder to safeguard the protection trip during heavy load conditions.

c) The Sub-contractor shall provide necessary interface equipment for communication between substation automation system and remote control centre and between Substation Automation system and regional System coordination centre (RSCC).

All necessary hardware and software shall be supplied except the communication link along with communication equipment between Substation Control room and Remote control centre/RSCC.

In sub-station automation system, for data transfer to RSCC , the contractor shall provide 2 Nos. gateways communicating to RSCC on IEC60870-5-101 as per clause 3.3 of Section-II Annexure-A of Tech. Spec.

Further in addition to above the bidder shall provide 4 Nos. ports on IEC-60870-5-104 redundant gateways which can support four different masters. Out of the 4 (four) , 3 (three) shall be used for day to day operation of the sub-station and 1 No. shall be used in future for RSCC Communication.

The total Number of ports on redundant gateways shall be as under (on each gateway)-

- | | | | |
|-----|--------------------|---|---------|
| i) | On IEC 60870-5-101 | : | 01No. |
| ii) | On IEC 60870-5-104 | : | 04 Nos. |

- d) Seven (7) number of 500 MVA, $(765 / \sqrt{3}) / (400 / \sqrt{3}) / 33$ kV, single phase auto transformers are used as two number bank of 1500 MVA, 765/ 400/ 33 kV, three phase auto transformers with one number unit as spare. The prices for protection of spare 1ph Auto transformer are deemed to be included in the Transformer protection panel prices. No claim for extra pricing shall be entertained at contract stage.
- e) The reactor Protection panel scope shall be as follows:
- i) 765kV Bus Reactor bay with 3 number of 80 MVAR, 765/ $\sqrt{3}$ kV, single phase reactors to be used as one number bank of 240 MVAR, 765 kV three phase bus reactor and one number unit as spare. The prices for the spare reactor protection are deemed to be included in the quoted reactor protection panel prices. No claim for extra pricing shall be entertained at contract stage.
 - ii) 765kV Line reactor where 3 numbers of 80 MVAR, 765/ $\sqrt{3}$ kV, single phase shunt reactors used as two banks of 240 MVAR Reactor for each line.
- f) In sub-station automation system , for data transfer to RSCC , the contractor shall provide 2 Nos. gateways communicating to RSCC on IEC60870-5-101 as per clause 3.3 of Setion-II Annexure-A of Tech. Spec.
Further in addition to above the bidder shall provide 4 Nos. ports on IEC-60870-5-104 redundant gateways which can support four different masters. Out of the 4 (four) , 3 (three) shall be used for day to day operation of the sub-station and 1 No. shall be used in future for RSCC Communication.
The total Number of ports on redundant gateways shall be as under (on each gateway)-
- i) On IEC 60870-5-101 : 01No.
 - ii) On IEC 60870-5-104 : 04 Nos.
- g) Following Circuit breakers are with Controlled Switching devices. Please refer project SLD attached along with Technical Specification for clarity –
- i) 765kV Circuit breakers (Bay wise) : 702 , 703 , 707, 708, 709 ,710, 711, 712
 - ii) 400kV Circuit breakers (Bay wise) : 411 , 412 , 414 , 415 , 417 , 418

The controller shall be mounted on the respective relay panel in Switchyard Panel room. Necessary space shall be considered on the panel. The actual dimension of the controller shall be furnished to successful bidder during detailed engineering.

3.0 QUALIFYING REQUIREMENT:

The manufacturer whose Control, Relay & Protection System (Control & protection Intelligent Electronic Devices (IEDs)), and Sub-station Automation System are offered should have designed, manufactured, tested, installed and commissioned Control, Relay & Protection system along with Sub-station Automation System which must be in satisfactory operation on (i) 400 kV system [for 765kV substation] & (ii) specified voltage level or above [for 400kV & below substation] for atleast 2 (two) years on the date of bid opening (05-09-2014).

AND

The Manufacturer or their joint venture or subsidiary company must have established repair, testing and integration (for at least 4 bays) facilities for Control, relay & protection System and Sub-station Automation System in India.

Please Note: Bidder shall provide all necessary documentary proof against the above requirements along with their offer. The qualification of the bidder shall be assessed based on the documentary proof attached in their offer. No further communication in this regard is envisaged.

4.0 TRAINING :

The bidder shall impart training to UPPTCL Personnel at sub-station site in the field of erection, testing , operation and maintenance of “Protection & Automation“ for 5 days .

The charges for tutorials & other training materials for the trainees shall be included in the prices quoted by bidder. No price implication shall be entertained at a later stage.

However, the travel lodging, & boarding expenses of employers personnel, if any shall be done by Employer.

5.0 PRECOMMISSIONING, COMMISSIONING, TRIAL-RUN & COMPLETION

a. PRECOMMISSIONING: As per requirements specified in Section II.

b. COMMISSIONING :

Charging of the facilities at rated voltage. Further, wherever appearing in this specification, the words –‘commissioning checks’, ‘installation checks’, ‘site tests’, ‘Performance guarantee tests for fire protection system’, are to be considered as ‘pre commissioning checks’.

c. TRIAL-RUN :

Operation of the facilities or any part thereof by BHEL immediately after the Commissioning for a continuous period of 72(Seventy two) hours. In case of interruption due to problem /failure in the equipment, the equipment manufacturer shall rectify the problem and after rectification, continuous 72 (Seventy two) hours period shall start after such rectification.

d. COMPLETION :

Upon successful completion of Trial-run.

‘Guarantee Test(s) and /or ‘Functional Guarantees’ are applicable for Substation Automation System as specified in Section-II.

e. The respective dates of commencement of erection, pre-commissioning, commissioning and trial –run activity by BHEL will be intimated to the equipment manufacturer from time to time , so that arrangements for supervising the activity can be made accordingly by the manufacturer .

6.0 BILL OF QUANTITY:

| S. No. | Description | Unit | Total Quantity |
|--------|---|------|----------------|
| 1.0 | 765 kV | | |
| 1.1 | Circuit Breaker Relay Panel | | |
| 1.1 a) | With Auto Reclose | Nos. | 5 |
| 1.1 b) | Without Auto Reclose | Nos. | 3 |
| 1.2 | Line Protection Panel | Nos. | 2 |
| 1.3 | Transformer Protection Panel (For both HV & MV side) | Nos. | 2 |
| 1.4 | Reactor Protection Panel | Nos. | 3 |
| 1.5 | Bus Bar Protection Panel(Duplicate Bus bar protection) | Set | 1 |
| 2.0 | 400 kV | | |
| 2.1 | Circuit Breaker Relay Panel | | |
| 2.1 a) | With Auto Reclose | Nos. | 12 |
| 2.1 b) | Without Auto Reclose | Nos. | 3 |
| 2.2 | Line Protection Panel | | |
| 2.2 a) | Line Protection Panel : Main-1 Distance Protection , Main-2 Distance Protection | Nos. | 5 |
| 2.2 b) | Line Protection Panel : Main-1 Distance , Main-2 Line Current Differential | Nos. | 2 |
| 2.3 | Reactor Protection Panel | Nos. | 1 |
| 2.4 | Bus Bar Protection Panel.(Duplicated Bus Bar Protection) | Nos. | 1 |
| 2.5 | Line Current Differential Relay for remote end of 400kV Agra (South) Line | Nos. | 2 |
| 3.0 | COMMON EQUIPMENTS | | |
| 3.1 | Time Synchronization Equipment | Nos. | 1 |

| | | | |
|--------|---|------|----|
| 3.2 | Relay Test Kit (As per Section –II of Technical Specification) | Nos. | 1 |
| 4.0 | SUBSTATION AUTOMATION | | |
| 4.1 | Complete Substation automation system for 765/400kV Agra (New) substation as per technical specification | | |
| 4.1 a) | 765 kV Bays | Nos. | 9 |
| 4.1 b) | 400kV Bays | Nos. | 15 |
| 4.1 c) | BCU for Control & Monitoring of Auxiliary System | Set | 1 |
| 5.0 | <p><u>Services:</u> Supervision of Testing and Commissioning of protection relays and complete Substation automation system at site. Scope shall be as follows :</p> <p>a) Testing & commissioning of main protection relays and Numerical Busbar protection including Relay Parameterization and configuration.</p> <p>b) Testing & commissioning of SAS system including termination of network/optical cables (complete with all end connectors, tees etc as required) .</p> <p>c) For network/optical cables which are in the bidder's Scope, the laying of cables shall be in BHEL scope. However, Optical cable will be laid under bidder's supervision. Splicing and Termination shall be in bidder's scope.</p> <p>d) Site acceptance Tests(SAT), Availability Test as per clause 12.0 of Section II Annexure A.</p> <p>e) Arranging all necessary tools , tackles and equipment for protection and communication testing including automatic relay test kit shall be bidder's responsibility.</p> <p>f) Maintenance services as per clause 11.1 of Section II Annexure-A</p> <p>g) Integration of IEC61850 communication based monitoring equipment on 765kV Transformer, 765kV Reactor & 400kV Reactor units , as per clause 2.0 a. i) of Section I</p> | Lot | 1 |
| 6.0 | <u>Services:</u> Testing & Commissioning of remote HMI at RCC/RSCC. | Lot | 1 |
| 7.0 | <u>Services:</u> Training Charges | Lot | 1 |

| | | | |
|---------|---|------|---|
| 8.0 | <u>Services:</u> a) Sketch showing routing of F.O Cable & GI Conduit Pipe giving BOQ (Item 4.t as per Annexure -1 of Section1) b) Relay Setting Calculation , Application checks c) Documentation as per clause 9.0 of Section –II Annexure-A | Lot | 1 |
| 9.0 | <u>Services :</u> Integration of FSC Signals with Substation SAS as per clause 2.0a ii) of Section –I | Lot | 1 |
| 10.0 | MANDATORY SPARES | | |
| 10.1 | Line Protection Panel Equipment | | |
| 10.1 a) | Main-I Numerical distance relay , one of each type (Complete Unit) | Nos. | 1 |
| 10.1 b) | Main-II Numerical distance relay , one of each type (Complete Unit) | Nos. | 1 |
| 10.1 c) | Numerical Line Current Differential relay , one of each type (Complete Unit) | Nos. | 2 |
| 10.2 | Transformers Protection Panel | | |
| 10.2 a) | Transformer differential protection relay | Nos. | 1 |
| 10.2 b) | Restricted earth fault protection relay with non- linear resister | Nos. | 1 |
| 10.3 | Reactor Protection Panel | | |
| 10.3 a) | Reactor differential protection relay | Nos. | 1 |
| 10.3 b) | Reactor Back up impedance relay (If standalone) | Nos. | 1 |
| 10.3 c) | Restricted earth fault protection relay with non-linear resistor | Nos. | 1 |
| 10.4 | Common Spares | | |
| 10.4 a) | Power supply module for Busbar protection. | Nos. | 1 |
| 10.4 b) | Bay unit for Bus Bar Protection (If Applicable) | Nos. | 1 |
| 10.4 c) | LBB Relay if Stand alone | Nos. | 1 |
| 10.5 | Sub-Station Automation system | | |
| 10.5 a) | Bay Control IED of each type | Set | 1 |

| | | | |
|---------|------------------------------|-----|---|
| 10.5 b) | Ethernet switch of each type | Set | 1 |
|---------|------------------------------|-----|---|

Note:

- a) The break-up of Substation Automation System is mentioned in Annexure –I to Section-I for reference. However if any additional item as per the specification for Substation Automation System (Section-II and its Annexures) is required to be supplied for completion of the system over and above the items indicated the same shall be indicated clearly in the offer. Otherwise, the same shall be deemed to be included in the offer.
- h) Itemized price for the breakup of Substation Automation System to be submitted when required by TBMM.
- i) BCUs shall be offered as part of respective protection panel.
- d) Proper sizing of inverter to be done by bidder, which shall be approved by PGCIL / BHEL.
- e) Central Units of both 765kV & 400 kV Numerical Busbar Protection Schemes shall have provision for addition of future bays as indicated in the SLD attached with Section II.
- f) Quantity of F.O Cable mentioned in Annexure-I is tentative .

7.0 TYPE TESTING, INSPECTION, TESTING & INSPECTION CERTIFICATE

The equipments supplied shall be type tested as per type tests specified in Section II. The type testing requirements shall be in line with clause 9.0 of Section III of this technical specification.

8.0 DEVIATIONS :

The bidder shall list all the deviation from the specification separately. Offers without specific deviation will be deemed to be totally in compliance with the specification and NO DEVIATION on any account will be entertained at a later date.

9.0 MANUFACTURING QUALITY PLAN:

Bidder has to follow Powergrid approved Manufacturing Quality Plan , SAT /FAT procedure at contract stage.

10.0 DRAWINGS and SCHEME

The documentation requirements detailed under Section-III shall be submitted to BHEL at various stages of contract. Softcopy of the drawings and schemes are to be submitted at contract stage. Preparation of AS- BUILT drawings is also in the scope of the bidder.

11.0 DOCUMENTS REQUIRED WITH OFFER

- a) Clause-wise confirmation/ comments.
- b) Bill of Material.
- c) Un-priced schedule as per BOQ at clause 6.0
- d) Filled up Guaranteed Technical Particulars
- e) Catalogue and Technical Leaflets for the offered Equipments
- f) Documentary proof against Qualifying requirement.

SECTION I**Annexure-I****Breakup of Substation Automation System (S.No. 4.0 of Bill of Quantity) :**

| S. No. | Description | Unit | Total Quantity |
|--------|---|------|----------------|
| 4.0 | SUBSTATION AUTOMATION | | |
| | Complete Substation automation system for 765/400kV Raichur (New) substation as per technical specification | | |
| a) | 765 kV Bay Control Unit for Line Bay | Set. | 2 |
| b) | 765kV Bay Control Unit for Bus Reactor Bay | Set. | 1 |
| c) | 765kV Bay Control Unit for Transformer Bay | Set. | 2 |
| d) | 765kV Bay Control Unit for Tie Bay | Set. | 3 |
| e) | 765kV Bay Control Unit for Future Bay | Set. | 1 |
| f) | 765kV Bay Control Unit for Bus CVTs | Set | 1 |
| g) | 400kV Bay Control Unit for Line Bay | Set | 7 |
| h) | 400kV Bay Control Unit for Transformer Bay | Set | 2 |
| i) | 400kV Bay Control Unit for Reactor Bay | Set | 1 |
| j) | 400kV Bay Control Unit for Tie Bay | Set | 5 |
| k) | BCU for controlling & monitoring of Auxiliary System | Set | 1 |
| l) | Station HMI (including necessary softwares) | Set | 2 |
| m) | Industrial Grade Station Server(Main / Standby with necessary softwares) | Set | 2 |
| n) | Disturbance Recorder Work Station (including necessary softwares) | Set | 1 |
| o) | Remote Work Station including HMI (with necessary softwares) and one printer | Set | 2 |
| p) | A4/A3 type colour Laser printer | No. | 1 |
| q) | Dot matrix printer | No. | 2 |

| | | | |
|----|---|-----|------|
| r) | Bay Level Ethernet switch for interconnecting Bay | Set | 7 |
| s) | Station Level managed Ethernet Switch (Hot/Standby) | Set | 2 |
| t) | Fibre Optic System Cable for SAS, 765/400kV Busbar protection | M | 5000 |
| u) | Redundant gateway to RCC and RSCC along with required Cables | Set | 1 |
| v) | Necessary hardware and Software for interface with RCC and existing RSCC. | Lot | 1 |
| w) | Inverter -working on station battery back-up. | No. | 2 |

SECTION - II

SECTION: CONTROL, RELAY & PROTECTION PANELS

1. TYPE OF PANELS

1.1 Simplex Panel

Simplex panel shall consist of a vertical front panel with equipment mounted thereon and having wiring access from rear for control panels & front-for relay/protection panels. In case of panel having width more than 800mm, double leaf-doors shall be provided. Doors shall have handles with either built-in locking facility or will be provided with pad-lock.

1.2 Duplex Panel

Duplex panel shall be walk-in tunnel type comprising two vertical front and rear panel sections connected back-on-back by formed sheet steel roof tie members and a central corridor in between. The corridor shall facilitate access to internal wiring and external cable connections. In case of number of duplex panels located in a row side by side, the central corridor shall be aligned to form a continuous passage. Both ends of the corridor shall be provided with double leaf doors with lift off hinges. Doors shall have handles either with built-in locking facility or shall be provided with pad-locks. Separate cable entries shall be provided for the front and rear panels. However, inter-connections between front and back panels shall be by means of inter panel wiring at the top of the panel.

2. CONSTRUCTIONAL FEATURES

2.1. Control and Relay Board shall be of panels of simplex or duplex type design as indicated in bill of quantity. It is the responsibility of the Bidder Contractor to ensure that the equipment specified and such unspecified complementary equipment required for completeness of the protective/control schemes be properly accommodated in the panels without congestion and if necessary, **either more number of panels or provide panels with larger dimensions**. No price increase at a later date on this account shall be allowed. However, the width of panels that are being offered to be placed in existing switchyard control rooms, should be in conformity with the space availability in the control room.

2.2. Panels shall be completely metal enclosed and shall be dust, moisture and vermin proof. The enclosure shall provide a degree of protection not less than IP-31 in accordance with IS: 2147.

2.3. Panels shall be free standing, floor mounting type and shall comprise structural frames completely enclosed with specially selected smooth finished, cold rolled sheet steel of thickness not less than 3 mm for weight bearing members of the panels such as base frame, front sheet and door frames, and 2.0mm for sides, door, top and bottom portions. There shall be sufficient reinforcement to provide level transportation and installation.

* Please Note : (i) "Section - Project" mentioned in this specification shall be read as "Section - I".
(ii) "Section - CTR" mentioned in this specification shall be read as "Section - III".

- 2.4. All doors, removable covers of panels shall be gasketed all around with synthetic ~~rubber~~ gaskets Neoprene/EPDM generally conforming with provision of IS 11149. However, XLPE gaskets can also be used for fixing protective glass doors. Ventilating louvers, if provided shall have screens and filters. The screens shall be made of either brass or GI wire mesh
- 2.5. Design, materials selection and workmanship shall be such as to result in neat appearance, inside and outside with no welds, rivets or bolt head apparent from outside, with all exterior surfaces true and smooth.
- 2.6. Panels shall have base frame with smooth bearing surface, which shall be fixed on the embedded foundation channels/insert plates. Anti vibration strips made of shock absorbing materials that shall be supplied by the contractor, **which** shall be placed between panel & base frame.
- 2.7. Cable entries to the panels shall be from the bottom. Cable gland plate fitted on the bottom of the panel shall be connected to earthing of the panel/station through a flexible braided copper conductor rigidly.
- 2.8. Relay/protection panels of modern modular construction would also be acceptable.

3. MOUNTING

- 3.1. All equipment on and in panels shall be mounted and completely wired to the terminal blocks ready for external connections. The equipment on front of panel shall be mounted flush.
- 3.2. Equipment shall be mounted such that removal and replacement can be accomplished individually without interruption of service to adjacent devices and are readily accessible without use of special tools. Terminal marking on the equipment shall be clearly visible.
- 3.3. The ^{Bidder} Contractor shall carry out cut out, mounting and wiring of the free issue items supplied by others which are to be mounted in his panel in accordance with the corresponding equipment manufacturer's drawings. Cut outs if any, provided for future mounting of equipment shall be properly blanked off with blanking plate.
- 3.4. The centre lines of switches, push buttons and indicating lamps shall be not less than 750mm from the bottom of the panel. The centre lines of relays, meters and recorders shall be not less than 450mm from the bottom of the panel.
- 3.5. The centre lines of switches, push buttons and indicating lamps shall be matched to give a neat and uniform appearance. Like wise the top lines of all meters, relays and recorders etc. shall be matched.
- 3.6. No equipment shall be mounted on the doors.
- 3.7. At existing station, panels shall be matched with other panels in the control room in respect of dimensions, colour, appearance and arrangement of equipment (centre lines of switches, push buttons and other equipment) on the front of the panel.

4. PANEL INTERNAL WIRING

- 4.1. Panels shall be supplied complete with interconnecting wiring provided between all electrical devices mounted and wired in the panels and between the devices and terminal blocks for the devices to be connected to equipment outside the panels. When panels are arranged to be located adjacent to each other all inter panel wiring and connections between the panels shall be carried out internally
- 4.2. All wiring shall be carried out with 650V grade, single core, stranded copper conductor wires with PVC insulation. The minimum size of the multi-stranded copper conductor used for internal wiring shall be as follows:
- All circuits except current transformer circuits and voltage transfer circuits meant for energy metering - one 1.5mm sq. per lead.
 - All current transformer circuits - one 2.5 sq.mm per lead.
 - Voltage transformer circuit (for energy meters): Two 2.5 mm sq. per lead.
- 4.3. All internal wiring shall be securely supported, neatly arranged, readily accessible and connected to equipment terminals and terminal blocks. Wiring gutters & troughs shall be used for this purpose.
- 4.4. Auxiliary bus wiring for AC and DC supplies, voltage transformer circuits, annunciation circuits and other common services shall be provided near the top of the panels running throughout the entire length of the panels.
- 4.5. Wire termination shall be made with solderless crimping type and tinned copper lugs, which firmly grip the conductor. Insulated sleeves shall be provided at all the wire terminations. Engraved core identification plastic ferrules marked to correspond with panel wiring diagram shall be fitted at both ends of each wire. Ferrules shall fit tightly on the wire and shall not fall off when the wire is disconnected from terminal blocks. All wires directly connected to trip circuit breaker or device shall be distinguished by the addition of red coloured unlettered ferrule.
- 4.6. Longitudinal troughs extending throughout the full length of the panel shall be preferred for inter panel wiring. Inter-connections to adjacent panel shall be brought out to a separate set of terminal blocks located near the slots of holes meant for taking the inter-connecting wires.
- 4.7. ^{Bidder} Contractor shall be solely responsible for the completeness and correctness of the internal wiring and for the proper functioning of the connected equipments.
- 5. TERMINAL BLOCKS**
- 5.1. All internal wiring to be connected to external equipment shall terminate on terminal blocks. Terminal blocks shall be 650 V grade and have 10 Amps. continuous rating, moulded piece, complete with insulated barriers, stud type terminals, washers, nuts and lock nuts. Markings on the terminal blocks shall correspond to wire number and terminal numbers on the wiring diagrams. All terminal blocks shall have shrouding with transparent unbreakable material.

- 5.2. Disconnecting type terminal blocks for current transformer and voltage transformer secondary leads shall be provided. Also current transformer secondary leads shall be provided with short circuiting and earthing facilities.
- 5.3. At least 20% spare terminals shall be provided on each panel and these spare terminals shall be uniformly distributed on all terminal blocks.
- 5.4. Unless otherwise specified, terminal blocks shall be suitable for connecting the following conductors of external cable on each side
- All CT & PT circuits: minimum of two of 2.5mm Sq. copper.
 - AC/DC Power Supply Circuits: One of 6mm Sq. Aluminium.
 - All other circuits: minimum of one of 2.5mm Sq. Copper.
- 5.5. There shall be a minimum clearance of 250mm between the first row of terminal blocks and the associated cable gland plate or panel side wall. Also the clearance between two rows of terminal blocks edges shall be minimum of 150mm.
- 5.6. Arrangement of the terminal block assemblies and the wiring channel within the enclosure shall be such that a row of terminal blocks is run in parallel and close proximity along each side of the wiring-duct to provide for convenient attachment of internal panel wiring. The side of the terminal block opposite the wiring duct shall be reserved for the external cable connections. All adjacent terminal blocks shall also share this field wiring corridor. All wiring shall be provided with adequate support inside the panels to hold them firmly and to enable free and flexible termination without causing strain on terminals.
- 5.7. The number and sizes of the Owner's multi core incoming external cables will be furnished to the ~~Contractor~~ ^{Bidder} after placement of the order. All necessary cable terminating accessories such as gland plates, supporting clamps & brackets, wiring troughs and gutters etc. (except glands & lugs) for external cables shall be included in the scope of supply.

6. PAINTING

The painting shall be carried out as detailed in Section-GTR. (Section-III)

7. MIMIC DIAGRAM

- 7.1. Coloured mimic diagram and symbols showing the exact representation of the system shall be provided in the front of control panels.
- 7.2. Mimic diagram shall be made preferably of anodised aluminium or plastic of approved fast colour material, which shall be screwed on to the panel and can be easily cleaned. The mimic bus shall be 2mm thick. The width of the mimic bus shall be 10mm for bus bars and 7mm for other connections. Painted overlaid mimic is also acceptable.
- 7.3. Mimic bus colour will be decided during detailed Engineering by the POWERGRID and shall be furnished to the successful Bidder during Engineering.
- 7.4. When semaphore indicators are used for equipment position, they shall be so mounted in the mimic that the equipment in close position shall

complete the continuity of mimic.

- 7.5. Indicating lamp, one for each phase, for each bus shall be provided on the mimic to indicate bus charged condition

8. NAME PLATES AND MARKINGS

- 8.1. All equipment mounted on front and rear side as well as equipment mounted inside the panels shall be provided with individual name plates with equipment designation engraved. Also on the top of each panel on front as well as rear side, large and bold nameplates shall be provided for circuit/feeder designation.
- 8.2. All front mounted equipment shall also be provided at the rear with individual name plates engraved with tag numbers corresponding to the one shown in the panel internal wiring to facilitate easy tracing of the wiring.
- 8.3. Each instrument and meter shall be prominently marked with the quantity measured e.g. KV, A, MW, etc. All relays and other devices shall be clearly marked with manufacturer's name, manufacturer's type, serial number and electrical rating data.
- 8.4. Name Plates shall be made of non-rusting metal or 3 ply lamicaid. Name plates shall be black with white engraving lettering.
- 8.5. Each switch shall bear clear inscription identifying its function e.g. 'BREAKER' '52A', "SYNCHRONISING" etc. Similar inscription shall also be provided on each device whose function is not other-wise identified. If any switch device does not bear this inscription separate name plate giving its function shall be provided for it. Switch shall also have clear inscription for each position indication e.g. "Trip- Neutral-Close", "ON-OFF", "R-Y-B-OFF" etc
- 8.6. All the panels shall be provided with name plate mounted inside the panel bearing LOA No & Date, Name of the Substation & feeder and reference drawing number.

9. MISCELLANEOUS ACCESSORIES

- 9.1. **Plug Point:** 240V, Single phase 50Hz, AC socket with switch suitable to accept 5 Amps and 15 Amps pin round standard Indian plug, shall be provided in the interior of each cubicle with ON-OFF switch.
- 9.2. **Interior Lighting:** Each panel shall be provided with a fluorescent lighting fixture rated for 240 Volts, single phase, 50 Hz supply for the interior illumination of the panel controlled by the respective panel door switch. Adequate lighting shall also be provided for the corridor in Duplex panels.
- 9.3. **Switches and Fuses:** Each panel shall be provided with necessary arrangements for receiving, distributing and isolating of DC and AC supplies for various control, signaling, lighting and space heater circuits. The incoming and sub-circuits shall be separately provided with Fuses. Selection of the main and sub-circuit Fuses rating shall be such as to ensure selective clearance of sub-circuit faults. Voltage transformer circuits for relaying and metering shall be protected by fuses. All fuses shall be HRC cartridge type conforming to IS: 13703 mounted on plug-in

type fuse bases. The short time fuse rating of Fuses shall be not less than 9 KA. Fuse carrier base shall have imprints of the fuse 'rating' and 'voltage'.

- 9.4. **Space Heater:** Each panel shall be provided with a thermostatically connected space heater rated for 240V, single phase, 50 Hz AC supply for the internal heating of the panel to prevent condensation of moisture. The fittings shall be complete with switch unit.

10. EARTHING

- 10.1. All panels shall be equipped with an earth bus securely fixed. Location of earth bus shall ensure no radiation interference from earth systems under various switching conditions of isolators and breakers. The material and the sizes of the bus bar shall be at least 25 X 6 sq.mm copper with threaded holes at a gap of 50 mm with provision of bolts and nuts for connection with cable armours and mounted equipment etc for effective earthing. When several panels are mounted adjoining each other, the earth bus shall be made continuous and necessary connectors and clamps for this purpose shall be included in the scope of supply of ~~Contractor~~ Bidder. Provision shall be made for extending the earth bus bars to future adjoining panels on either side.

- 10.2. Provision shall be made on each bus bar of the end panels for connecting Substation earthing grid. Necessary terminal clamps and connectors for this purpose shall be included in the scope of supply of ~~Contractor~~ Bidder.

- 10.3. All metallic cases of relays, instruments and other panel mounted equipment including gland plate, shall be connected to the earth bus by copper wires of size not less than 2.5 sq. mm. The colour code of earthing wires shall be green.

- 10.4. Looping of earth connections which would result in loss of earth connection to other devices when the loop is broken, shall not be permitted. However, looping of earth connections between equipment to provide alternative paths to earth bus shall be provided.

- 10.5. VT and CT secondary neutral or common lead shall be earthed at one place only at the terminal blocks where they enter the panel. Such earthing shall be made through links so that earthing may be removed from one group without disturbing continuity of earthing system for other groups.

- 10.6. An electrostatic discharge point arrangement shall be provided in each panel so as to discharge human body before he handles the equipments inside the panels.

11. INDICATING INSTRUMENTS & TRANSDUCERS FOR CONTROL PANEL:

All instruments, meters and transducers shall be enclosed in dust proof, moisture resistant, black finished cases and shall be suitable for tropical use. All megawatt , megavar, Bus voltage and frequency indicating instruments shall be provided with individual transducers and these shall be calibrated along with transducers to read directly the primary quantities. They shall be accurately adjusted and calibrated at works and

shall have means of calibration check and adjustment at site. The supplier shall submit calibration certificates at the time of delivery. However no separate transducers are envisaged for digital bus voltmeters and digital frequency meters and the indicating meters provided in the synchronising equipment.

11.1. Indicating Instruments

- 11.1.1. Unless otherwise specified, all electrical indicating instruments shall be of digital type suitable for flush mounting.
- 11.1.2. Instruments shall have 4-digit display; display height being not less than 25 mm
- 11.1.3. Instrument shall conform to relevant IS and shall have an accuracy class of 1.5 or better. Watt and Var meters shall have an indication of (+) and (-) to indicate EXPORT and IMPORT respectively.
- 11.1.4. Digital voltage and frequency meters shall be of class: 0.5 and shall have digital display of 5 and 4 digits respectively, with display size, not less than 25mm (height).

11.2. Transducers

- 11.2.1. Transducers (for use with Indicating Instruments and Telemetry/Data Communication application) shall in general conform to IEC:688-1
- 11.2.2. The transducers shall be suitable for measurement of active power, reactive power, voltage, current and frequency in three phase four wire unbalanced system.
- 11.2.3. The input to the transducers will be from sub-station current & potential transformers. The output shall be in milli ampere D.C. proportional to the input & it shall be possible to feed the output current directly to the telemetry terminal or indicating instruments.
- 11.2.4. The transducer characteristic shall be linear throughout the measuring range.
- 11.2.5. The transducer output shall be load independent.
- 11.2.6. The input & output of the transducer shall be galvanically isolated.
- 11.2.7. Each transducer shall be housed in a separate compact case and have suitable terminals for inputs & outputs.
- 11.2.8. The transducers shall be suitably protected against transient high peaks of voltage & current.
- 11.2.9. The transducer shall withstand indefinitely without damage and work satisfactorily at 120% of the rated voltage and 120% of the rated input current as applicable.
- 11.2.10. All the transducers shall have an output of 4-20 mA.
- 11.2.11. The response time of the transducers shall be less than 1 second.
- 11.2.12. The accuracy class of transducers shall be 1.0 or better for voltage/current transducer, 0.5 or better for watt/VAR transducer and 0.2 or better for frequency transducer.

- 11.2.13. The transducers shall have a low AC ripple on output less than 1%.
- 11.2.14. The transducer shall have dual output.

12. ANNUNCIATION SYSTEM for Control Panel

- 12.1. Alarm annunciation system shall be provided in the control board by means of visual and audible alarm in order to draw the attention of the operator to the abnormal operating conditions or the operation of some protective devices. The annunciation equipment shall be suitable for operation on the voltages specified in this specification.
- 12.2. The visual annunciation shall be provided by annunciation facia, mounted flush on the top of the control panels.
- 12.3. The annunciation facia shall be provided with translucent plastic window for alarm point with approximate size of 35mm x 50mm. The facia plates shall be engraved in black lettering with respective inscriptions. Alarm inscriptions shall be engraved on each window in not more than three lines and size of the lettering shall not be less than 5 mm.
- 12.4. Each annunciation window shall be provided with two white lamps in parallel to provide safety against lamp failure. Long life lamps shall be used. The transparency of cover plates and wattage of the lamps provided in the facia windows shall be adequate to ensure clear visibility of the inscriptions in the control room having high illumination intensity (350 Lux), from the location of the operator's desk.
- 12.5. All Trip facia shall have red colour and all Non-trip facia shall have white colour.
- 12.6. The audible alarm shall be provided by Buzzer/ Hooter /Bell having different sounds and shall be used as follows.

| | |
|--------|-------------------------|
| Hooter | Alarm Annunciation |
| Bell | Annunciation DC failure |
| Buzzer | AC supply failure |
- 12.7. Sequence of operation of the annunciator shall be as follows :

| Sl. NO. | Alarm Condition | Fault Contact | Visual Annunciation | Audible Annunciation |
|---------|-------------------------------|---------------|---------------------|----------------------|
| 1. | Normal | Open | OFF | OFF |
| 2. | Abnormal | Close | Flashing | ON |
| 3. | Accept Push Button Pressed | Close | Steady On | OFF |
| | | Open | Steady On | OFF |
| 4. | Reset Push Button Pressed | Close | On | OFF |
| | | Open | Off | OFF |
| 5. | Lamp Test Push Button Pressed | Open | Steady On | OFF |

- 12.8. Audible annunciation for the failure of DC supply to the annunciation

system shall be provided and this annunciation shall operate on 240 Volts AC supply. On failure of the DC to the annunciation system for more than 2 or 3 seconds (adjustable setting), a bell shall sound. A separate push button shall be provided for the cancellation of this audible alarm alone but the facia window shall remain steadily lighted till the supply to annunciation system is restored.

- 12.9. A separate voltage check relay shall be provided to monitor the failure of supply (240V AC) to the scheme mentioned in Clause above. If the failure of supply exists for more than 2 to 3 seconds, this relay shall initiate visual and audible annunciation. Visual and audible annunciation for the failure of AC supply to the annunciation system shall be provided and this annunciation shall operate on Annunciation DC and buzzer shall sound.
- 12.10. The annunciation system described above shall meet the following additional requirements :
- a) The annunciation system shall be capable of catering to at least 20 simultaneous signals at a time.
 - b) One set of the following push buttons shall be provided on each control panel:
 - Reset push button for annunciation system
 - Accept push button for annunciation system
 - Lamp test push button for testing the facia windows
 - c) One set of the following items shall be provided common for all the control panel (not applicable for extension of substation) :
 - Flasher relay for annunciation system
 - Push button for Flasher test
 - Three Push buttons for test of all audible alarm systems
 - d) These testing circuits shall be so connected that while testing is being done, it shall not prevent the registering of any new annunciation that may land during the test.
 - e) The annunciation shall be repetitive type and shall be capable of registering the fleeting signal. Minimum duration of the fleeting signal registered by the system shall be 15 milli seconds.
 - f) In case of static annunciator scheme, special precaution shall be taken to ensure that spurious alarm condition does not appear due to influence of external electromagnetic/ electrostatic interference on the annunciator wiring and switching disturbances from the neighbouring circuits within the panels and the static annunciator shall meet the high voltage susceptibility test , impulse voltage with stand test , high frequency disturbance test– class III and fast transient disturbance test –level III as per IEC 60255.
- 12.11. The annunciation system to be supplied for existing sub-stations shall be engineered as an extension to the existing scheme.

13. SWITCHES

- 13.1. Control and instrument switches shall be rotary operated type with escutcheon plates clearly marked to show operating position and circuit designation plates and suitable for flush mounting with only switch front plate and operating handle projecting out.
- 13.2. The selection of operating handles for the different types of switches shall be as follows :
- Breaker, Isolator control switches : Pistol grip, black
- Synchronising switches : Oval, Black, Keyed handle (one common removable handle for a group of switches or locking facility having common Key)
- synchronising Selector switches : Oval or knob, black
- Instrument switches : Round, knurled, black
- Protection Transfer switch : Pistol grip, lockable and black.
- 13.3. The control switch of breaker and isolator shall be of spring return to neutral type. The switch shall have spring return from close and trip positions to "after close" and "after trip" positions respectively.
- 13.4. Instrument selection switches shall be of maintained contact (stay put) type. Ammeter selection switches shall have make-before-break type contacts so as to prevent open circuiting of CT secondary when changing the position of the switch. Voltmeter transfer switches for AC shall be suitable for reading all line- to-line and line-to-neutral voltages for non-effectively earthed systems and for reading all line to line voltages for effectively earthed systems.
- 13.5. Synchronising switches shall be of maintained contact (stay put) type having a common removable handle for a group of switches. The handle shall be removable only in the OFF position and it shall be co-ordinated to fit in to all the synchronising switches. These switches shall be arranged to connect the synchronising equipment when turned to the 'ON' position. One contact of each switch shall be connected in the closing circuit of the respective breaker so that the breaker cannot be closed until the switch is turned to the 'ON' position.
- 13.6. Lockable type of switches which can be locked in particular positions shall be provided when specified. The key locks shall be fitted on the operating handles.
- 13.7. The contacts of all switches shall preferably open and close with snap action to minimise arcing. Contacts of switches shall be spring assisted and contact faces shall be with rivets of pure silver or silver alloy. Springs shall not be used as current carrying parts
- 13.8. The contact combination and their operation shall be such as to give completeness to the interlock and function of the scheme.

13.9. The contact rating of the switches shall be as follows :

| Description | Contact Rating in Amps | | |
|---|------------------------|--------|---------|
| | 220V DC | 50V DC | 240V AC |
| Make and carry Continuously | 10 | 10 | 10 |
| Make and carry for 0.5 sec. | 30 | 30 | 30 |
| Break for Resistive load | 3 | 20 | 7 |
| Break for Inductive load with L/R = 40m sec. | 0.2 | - | - |

14. INDICATING LAMPS

14.1. Indicating lamps shall be of cluster LED type suitable for panel mounting with rear terminal connections. Lamps shall be provided with series connected resistors preferably built in the lamp assembly. Lamps shall have translucent lamp covers to diffuse lights coloured red, green, amber, clear white or blue as specified. The lamp cover shall be preferably of screwed type, unbreakable and moulded from heat resisting material.

14.2. The lamps shall be provided with suitable resistors.

14.3. Lamps and lenses shall be interchangeable and easily replaceable from the front of the panel. Tools, if required for replacing the bulbs and lenses shall also be included in the scope of the supply.

14.4. The indicating lamps with resistors shall withstand 120% of rated voltage on a continuous basis.

15. POSITION INDICATORS (if Applicable)

15.1. Position indicators of "SEMAPHORE" type shall be provided when specified as part of the mimic diagrams on panels for indicating the position of circuit breakers, isolating/earthing switches etc. The indicator shall be suitable for semi-flush mounting with only the front disc projecting out and with terminal connection from the rear. Their strips shall be of the same colour as the associated mimic.

15.2. Position indicator shall be suitable for DC Voltage as specified. When the supervised object is in the closed position, the pointer of the indicator

shall take up a position in line with the mimic bus bars, and at right angles to them when the object is in the open position. When the supply failure to the indicator occurs, the pointer shall take up an intermediate position to indicate the supply failure.

- 15.3. The rating of the indicator shall not exceed 2.5 W.
- 15.4. The position indicators shall withstand 120% of rated voltage on a continuous basis.

16. SYNCHRONISING EQUIPMENT

- 16.1. For sub-station equipped with sub-station Automation system, the requirement of synchronisation is specified in section Sub-station Automation System and the same shall prevail. For other sub-station which is not equipped with Sub-sub-station automation system following shall be applicable as per requirement.
- 16.1. The synchronising instruments shall be mounted either on a synchronising trolley or on a synchronising panel. The panel/ trolley shall be equipped with double analog voltmeters and double analog frequency meters, synchroscope and lamps fully wired. The size of voltmeters and frequency meters provided in the synchronising panel shall not be less than 144 X 144 sq.mm. Suitable auxiliary voltage transformers wherever necessary shall also be provided for synchronising condition. In case the synchroscope is not continuously rated, a synchroscope cut-off switch shall be provided and an indicating lamp to indicate that the synchroscope is energised, shall also be provided
- 16.1. Synchronising check relay with necessary ancillary equipment's shall be provided which shall permit breakers to close after checking the requirements of synchronising of incoming and running supply. The phase angle setting shall not exceed 35 degree and have voltage difference setting not exceeding 10%. This relay shall have a response time of less than 200 milliseconds when the two system conditions are met within present limits and with the timer disconnected. The relay shall have a frequency difference setting not exceeding 0.45% at rated value and at the minimum time setting. The relay shall have an adjustable time setting range of 0.5-20 seconds. A guard relay shall be provided to prevent the closing attempt by means of synchronising check relay when control switch is kept in closed position long before the two systems are in synchronism
- 16.1. The synchronising panel shall be draw out and swing type which can be swivelled in left and right direction. The synchronising panel shall be placed along with control panels and the number of synchronising panel shall be as indicated in BPS*. The incoming and running bus wires of VT secondary shall be connected and run as bus wires in the control panels and will be extended to synchronising panel for synchronisation of circuit breakers. The selector switch provided for each circuit breaker in respective control panels shall be lockable type with a common key so that only one selector switch is kept in synchronising mode at a time.
- 16.1. Alternatively, the trolley shall be of mobile type with four rubber-padding wheels capable of rotating in 360 degree around the vertical axis.

BPS* - As per BOQ given in Section -I of the TS.

Suitable bumpers with rubber padding shall be provided all around the trolley to prevent any accidental damage to any panel in the control room while the trolley is in movement. The trolley shall have two meter long flexible cord fully wired to the instruments and terminated in a plug in order to facilitate connecting the trolley to any of the panels. The receptacle to accept the plug shall be provided on the panel.

- 16.1. At existing sub-stations, the synchronising scheme shall be engineered to be compatible with the existing synchronising scheme and synchronising socket/switch on the panel. In substations, where synchronising panels are available, the bidder shall carry out the shifting of the above panels, if required, to facilitate the extension of control panel placement.

17. RELAYS

- 17.1. All relays shall conform to the requirements of IS: 3231/IEC-60255/IEC 61000 or other applicable standards. Relays shall be suitable for flush or semi-flush mounting on the front with connections from the rear.
- 17.2. All protective relays shall be of numerical type and communication protocol shall be as per IEC 61850. Further, the test levels of EMI as indicated in IEC 61850 shall be applicable to these relays.
- 17.3. All protective relays shall be in draw out or plug-in type/modular cases with proper testing facilities. Necessary test plugs/test handles shall be supplied loose and shall be included in contractor's scope of supply.
- 17.4. All AC operated relays shall be suitable for operation at 50 Hz. AC Voltage operated relays shall be suitable for 110 Volts VT secondary and current operated relays for 1 amp CT secondary. All DC operated relays and timers shall be designed for the DC voltage specified, and shall operate satisfactorily between 80% and 110% of rated voltage. Voltage operated relays shall have adequate thermal capacity for continuous operation.
- 17.5. The protective relays shall be suitable for efficient and reliable operation of the protection scheme described in the specification. Necessary auxiliary relays and timers required for interlocking schemes for multiplying of contacts suiting contact duties of protective relays and monitoring of control supplies and circuits, lockout relay monitoring circuits etc. also required for the complete protection schemes described in the specification shall be provided. All protective relays shall be provided with at least two pairs of potential free isolated output contacts. Auxiliary relays and timers shall have pairs of contacts as required to complete the scheme; contacts shall be silver faced with spring action. Relay case shall have adequate number of terminals for making potential free external connections to the relay coils and contacts, including spare contacts.
- 17.6. Timers shall be of solid state type. Time delay in terms of milliseconds obtained by the external capacitor resistor combination is not preferred and shall be avoided.
- 17.7. No control relay, which shall trip the power circuit breaker when the relay is de-energised, shall be employed in the circuits.

- 17.8. Provision shall be made for easy isolation of trip circuits of each relay for the purpose of testing and maintenance.
- 17.9. Auxiliary seal-in-units provided on the protective relays shall preferably be of shunt reinforcement type. If series relays are used the following shall be strictly ensured:
- (a) The operating time of the series seal-in-unit shall be sufficiently shorter than that of the trip coil or trip relay in series with which it operates to ensure definite operation of the flag indicator of the relay.
 - (b) Seal-in-unit shall obtain adequate current for operation when one or more relays operate simultaneously.
 - (c) Impedance of the seal-in-unit shall be small enough to permit satisfactory operation of the trip coil on trip relays when the D.C. Supply Voltage is minimum.
 - (d) Trip-circuit seal-in is required for all trip outputs, irrespective of the magnitude of the interrupted current. The trip-circuit seal-in logic shall not only seal-in the trip output(s), but also the relevant initiation signals to other scheme functions, (e.g. initiate signals to the circuit-breaker failure function, reclosing function etc.), and the alarm output signals.
 - (e) Two methods of seal-in are required, one based on the measurement of AC current, catering for those circumstances for which the interrupted current is above a set threshold, and one based on a fixed time duration, catering for those circumstances for which the interrupted current is small (below the set threshold).
 - (f) For the current seal-in method, the seal-in shall be maintained until the circuit-breaker opens, at which time the seal-in shall reset and the seal-in method shall not now revert to the fixed time duration method. For this seal-in method, the seal-in shall be maintained for the set time duration. For the line protection schemes, this time duration shall be independently settable for single- and three-pole tripping.
 - (g) Seal-in by way of current or by way of the fixed duration timer shall occur irrespective of whether the trip command originates from within the main protection device itself (from any of the internal protection functions), or from an external device with its trip output routed through the main protection device for tripping. Trip-circuit seal-in shall not take place under sub-harmonic conditions (e.g. reactor ring down).
- 17.10. The setting ranges of the relays offered, if different from the ones specified shall also be acceptable if they meet the functional requirements.
- 17.11. Any alternative/additional protections or relays considered necessary for providing complete effective and reliable protection shall also be offered separately. The acceptance of this alternative/ additional equipment shall lie with the POWERGRID.
- 17.12. All relays and their drawings shall have phase indications as R-Red, Y-yellow, B-blue
- 17.13. For numerical relays, the scope shall include the following:

- a) Necessary software and hardware to up/down load the data to/from the relay from/to the personal computer installed in the substation. However, the supply of PC is not covered under this clause.
- b) The relay shall have suitable communication facility for future connectivity to SCADA. The relay shall be capable of supporting IEC 61850 protocol.
- c) In case of line protection and transformer/reactor protection, the features like fault recorder and event logging function as available including available as optional feature in these relays shall be supplied and activated at no extra cost to the owner. Also necessary software/hardware for automatic uploading to station HMI/DR work station (as applicable) shall be supplied. It is to be clearly understood that these shall be in addition to Fault recorder function as specified at clause no. 28.

18. TRANSMISSION LINE PROTECTION

- 18.1. All relays shall be suitable for series compensated line.
- 18.2. The line protection relays are required to protect the line and clear the faults on line within shortest possible time with reliability, selectivity and full sensitivity to all type of faults on lines. The general concept is to have two main protections having equal performance requirement specially in respect of time as called Main-I and Main-II for 765kV, 400KV and 220KV transmission lines and Main and back up protection for 132 KV transmission lines.
- ~~18.3.~~ The Transmission system for which the line protection equipment are required is indicated in Section (I) Project. ~~shown in the reference drawing/document(s). The length of lines and the line parameters (Electrical Constants) are also indicated there.~~
- 18.4. The maximum fault current could be as high as 63kA but the minimum fault current could be as low as 20% of rated current of CT secondary. The starting & measuring relays characteristics should be satisfactory under these extremely varying conditions.
- 18.5. The protective relays shall be suitable for use with capacitor voltage transformers having non-electronic damping and transient response as per IEC.
- 18.6. Fault Recorder, Distance to fault Locator and Over voltage relay (stage - 1/2) functions if offered as an integral part of line protection relays, shall be acceptable provided these meet the technical requirements as specified in the respective clauses.
- 18.7. Auto reclose relay function if offered as an integral part of line distance protection relay, shall be acceptable **for 132 KV lines only** provided the auto reclose relay feature meets the technical requirements as specified in the respective clause.
- 18.8. The following protections shall be provided for each of the Transmission lines:

For 765 KV, 400 KV & 220KV

* For 400KV D/c Agra - Agra (South) line, Main - II protection shall be Current Differential protection refer Annexure B of Section II.

Main-I: Numerical distance protection scheme

* **Main-II:** Numerical distance protection scheme of a make different from that of Main -I

Further, If specified in the "Section-(Project)", back up Over current and Earth fault protection shall be provided instead of Main -II protection scheme for 220KV lines to match with requirements at the remote ends.

For 132KV

Main: Numerical distance protection scheme

Back up: Directional Over Current and Earth fault Protection

The detailed description of line protections is given here under.

18.9. Main-I and Main-II Distance Protection scheme:

- (a) shall have continuous self monitoring and diagnostic feature
- (b) shall be non-switched type with separate measurements for all phase to phase and phase to ground faults
- (c) shall have stepped time-distance characteristics and three independent zones (zone 1, zone-2 and zone-3)
- (d) shall have mho or quadrilateral or other suitably shaped characteristics for zone-1, zone-2 and zone-3
- (e) shall have following maximum operating time (including trip relay time, if any) under given set of conditions and with CVT being used on line (with all filters included)

(i) for 765 KV, 400 KV & 220 KV lines:

| | | |
|---------------------------------------|-------------------|---|
| For Source to Impedance ratio: | 4 | 15 |
| Relay setting (Ohms) | (10 or 20) and 2 | 2 |
| Fault Locations | 50 | 50 |
| (as % of relay setting) | | |
| Fault resistance (Ohms) | 0 | 0 |
| Maximum operating time (Milliseconds) | 40 for all faults | 45 for 3 ph. Faults & 60 for all other faults |

(ii) for 132 KV lines:

A relaxation of 5 ms in above timings is allowed for 132 KV lines.

- (f) The relay shall have an adjustable characteristics angle setting range of 30 -85 degree or shall have independent resistance(R) and reactance (X) setting.
- (g) shall have two independent continuously variable time setting range of 0-3 seconds for zone-2 and 0-5 seconds for zone-3
- (h) shall have resetting time of less than 55 milli-seconds (including the resetting time of trip relays)
- (i) shall have facilities for offset features with adjustable 10-20% of Zone-3 setting

- (j) shall have variable residual compensation
- (k) shall have memory circuits with defined characteristics in all three phases to ensure correct operation during close-up 3 phase faults and other adverse conditions and shall operate instantaneously when circuit breaker is closed to zero-volt 3 phase fault
- (l) shall have weak end in-feed feature
- (m) shall be suitable for single & three phase tripping ~~However relays offered for 132 kV lines provided with mechanically ganged circuit breakers single pole tripping need not to be provided.~~
- (n) shall have a continuous current rating of two times of rated current. The voltage circuit shall be capable of operation at 1.2 times rated voltage. The relay shall also be capable of carrying a high short time current of 70 times rated current without damage for a period of 1 sec.
- (o) shall be provided with necessary self reset type trip duty contacts for completion of the scheme (Minimum number of these trip duty contacts shall be four per phase) either through built in or through separate high speed trip relays. Making capacity of these trip contacts shall be 30 amp for 0.2 seconds with an inductive load of L/R > 10 mill seconds. If separate high speed trip relays are used, the operating time of the same shall not be more than 10 milliseconds
- (p) shall be suitable for use in permissive under reach/ over reach/ blocking communication mode
- (q) shall have suitable number of potential free contacts for Carrier aided Tripping, Auto reclosing, CB failure, Disturbance recorder & Data acquisition system
- (r) include power swing blocking protection which shall
 - have suitable setting range to encircle the distance protection described above
 - block tripping during power swing conditions
 - release blocking in the event of actual fault
- (s) include fuse failure protection which shall monitor all the three fuses of C.V.T. and associated cable against open circuit
 - inhibit trip circuits on operation and initiate annunciation
 - have an operating time less than 7 milliseconds
 - remain inoperative for system earth faults
- (t) include a directional back up Inverse Definite Minimum Time (IDMT) earth fault relay with normal inverse characteristics as per IEC 60255-3 as a built in feature or as a separate unit for 765kV, 400 KV and 220KV transmission lines
- (u) Must have a current reversal guard feature.

18.10. Back-up Directional Over Current and Earth fault protection scheme

- (a) shall have three over current and one earth fault element(s) which shall be either independent or composite unit(s)
- (b) shall include necessary VT fuse failure relays for alarm purposes
- (c) **over current elements** shall
 - have IDMT characteristic with a definite minimum time of 3.0 seconds at 10 times setting
 - have a variable setting range of 50-200% of rated current
 - have a characteristic angle of 30/45 degree lead
 - include hand reset flag indicators or LEDs
- (d) **earth fault element** shall
 - have IDMT characteristic with a definite minimum time of 3.0 seconds at 10 times setting
 - have a variable setting range of 20-80% of rated current
 - have a characteristic angle of 45/60 degree lag
 - include hand reset flag indicators or LEDs
 - include necessary separate interposing voltage transformers or have internal feature in the relay for open delta voltage to the relay

18.11. LINE OVER VOLTAGE PROTECTION RELAY shall

- (a) monitor all three phases
- (b) have two independent stages
- (c) stage- I & II as built-in with line distance relays Main I & II respectively are acceptable
- (d) have an adjustable setting range of 100-170% of rated voltage with an adjustable time delay range of 1 to 60 seconds for the first stage
- (e) have an adjustable setting range of 100-170% of rated voltage with a time delay of 100-200 mill seconds for the second stage
- (f) be tuned to power frequency
- (g) provided with separate operation indicators (flag target) for each stage relays
- (h) have a drop-off to pick-up ratio greater than 95%
- (i) provide separate out-put contacts for each 'Phase' and stage for breaker trip relays, event logger and other scheme requirements

18.12. All trip relays used in transmission line protection scheme shall be of self/electrical reset type depending on application requirement.

19. CIRCUIT BREAKER PROTECTION:

This shall include following functions:

19.1. **Numerical AUTO RECLOSING function shall**

- (a) have single phase and three-phase reclosing facilities
- (b) have a continuously variable single phase dead time range of 0.1-2 seconds
- ~~(c) have a continuously variable three phase dead time range of 0.1-2 seconds~~
- (d) have a continuously variable reclaim time range of 5-300 seconds
- (e) incorporate a ~~two~~ four-position selector switch, from which single phase/~~three phase/single and three phase~~ auto-reclosure and non-auto reclosure mode can be selected. Alternatively, the mode of auto reclosing can be selected through programming.
- ~~(f) have facilities for selecting check synchronising or dead line charging features. It shall be possible at any time to change the required feature by reconnection of links.~~
- (g) be of single shot type
- (h) have priority circuit to closing of both circuit breakers in case one and half breaker arrangements to allow sequential closing of breakers
- ~~(i) include check synchronising relay which shall
 - ~~• have a time setting continuously variable between 0.5-5 seconds with a facility of additional 10 seconds~~
 - ~~• have a response time within 200 milli seconds with the timer disconnected.~~
 - ~~• have a phase angle setting not exceeding 35 degree~~
 - ~~• have a voltage difference setting not exceeding 10%~~
 - ~~• include dead line charging relay, which shall~~
 - ~~• have two sets of relays and each set shall be able to monitor the three phase voltage where one set shall be connected to the line CVTs with a fixed setting of 20% of rated voltage and the other set shall be connected to the bus CVTs with a fixed setting of 80% of rated voltage.~~
 - ~~• incorporate necessary auxiliary relays and timers to give comprehensive scheme~~~~
- (j) However, Auto-reclose as in built function of bay controller unit (BCU) (if supplied) provided for sub-station automation system is also acceptable.

19.2. **LOCAL BREAKER BACK-UP PROTECTION SCHEME shall**

- (a) be triple pole type
- (b) have an operating time of less than 15 milli seconds
- (c) have a resetting time of less than 15 milli seconds
- (d) have three over current elements

- (e) be arranged to get individual initiation from the corresponding phase of main protections of line for each over current element. However, common three phase initiation is acceptable for other protections and transformer /reactor equipment protections
- (f) have a setting range of 20-80% of rated current
- (g) have a continuous thermal withstand two times rated current irrespective of the setting
- (h) have a timer with continuously adjustable setting range of 0.1-1 seconds
- (i) have necessary auxiliary relays to make a comprehensive scheme
- (j) be similar relays for complete scope of work as per specification

20. REACTOR PROTECTION

20.1. Differential Protection Relay shall

- (a) be triple pole type
- (b) have operation time less than 25 milli-seconds at 5 times setting
- (c) be tuned to system frequency
- (d) have current setting range of 10 to 40% of 1 Amp. or a suitable voltage setting range
- (e) be high impedance / biased differential type
- (f) be stable for all external faults

20.2. Restricted Earth Fault Protection Relay shall

- (a) be single pole type
- (b) be of current/voltage operated high impedance type
- (c) have a current setting of 10-40% of 1 Amp./have a suitable voltage setting range
- (d) be tuned to system frequency
- (e) have a suitable non-linear resistor to limit the peak voltage to 1000 Volts

20.3. Back up impedance protection Relay shall

- (a) be triple pole type, with faulty phase identification/ indication
- (b) be single step polarised 'mho' distance/ impedance relay suitable for measuring phase to ground and phase to phase faults
- (c) have adequate ohmic setting range to cover at least 60% of the impedance of the reactor and shall be continuously variable
- (d) have an adjustable characteristic angle of 30-80 degree
- (e) have a definite time delay relay with a continuously adjustable setting range of 0.2-2.0 seconds

- (f) include VT failure relay which shall block the tripping during VT fuse failure condition

20.4. Further, Reactor auxiliary protections contacts (Buchholz, PRV, Oil Temperature, Winding Temperature etc.) can be wired suitably in above protections or provide separate Flag relays/Auxiliary relays as per scheme requirements.

21. TRANSFORMER PROTECTION

All transformer protection functions may be grouped into Group-I and Group-II protections in the following manner:

Group-I Protection: Following protection functions may be provided in Group-I Transformer protection relay:

- a) Differential Protection as per clause no. 21.1
- b) Over fluxing Protection for HV side as per clause no. 21.2
- c) Direction Over current and earth fault protection for HV side as per clause no. 21.4
- d) Over Load Protection as per clause no. 21.5

Group-II Protection: Following protection functions may be provided in Group-II Transformer protection relay:

- e) REF Protection as per clause no. 21.3
- f) Over fluxing Protection for IV/LV side as per clause no. 21.2
- g) Direction Over current and earth fault protection for IV/LV side as per clause no. 21.4
- h) Neutral Current Relay for Single Phase Transformer Bank as per clause no. 21.6

The various protections as built-in function of Group I/II protections shall be accepted only if the functional requirements of corresponding protections as specified in clause no. 21.1 to 21.6 are met otherwise separate protection relay(s) shall be offered.

21.1. Transformer differential protection scheme shall

- (a) be triple pole type, with faulty phase identification/ indication
- (b) have an operating time not greater than 30 milli seconds at 5 times the rated current
- (c) have three instantaneous high set over-current units
- (d) have an adjustable bias setting range of 20-50%
- (e) be suitable for rated current of 1 Amp.
- (f) have second harmonic or other inrush proof features and also should be stable under normal over fluxing conditions. Magnetising inrush proof feature shall not be achieved through

any intentional time delay e.g. use of timers to block relay operation or using disc operated relays

- (g) have an operating current setting of 15% or less
- (h) include necessary separate interposing current transformers for angle and ratio correction or have internal feature in the relay to take care of the angle & ratio correction
- (i) have a fault recording feature to record graphic form of instantaneous values of following analogue channels during faults and disturbances for the pre fault and post fault period:

current in all three windings in nine analogue channels in case of 400kV class and above transformers or 6 analogue channels for lower voltage transformers and **Voltage in one channel**

The disturbance recorder shall have the facility to record the following external digital channel signals apart from the digital signals pertaining to differential relay:

1. REF protection operated
2. HV Breaker status (Main and tie)
3. IV Breaker status
4. Buchholz /OLTC Buchholz alarm / trip etc.
5. WTI/OTI/PRD alarm/trip of transformer etc.

Necessary hardware and software, for automatic up-loading the data captured by disturbance recorder to the personal computer (**DR Work Station**) available in the substation, shall be included in the scope.

21.2. **Over Fluxing Protection Relays shall**

- (a) operate on the principle of Voltage to frequency ratio and shall be phase to phase connected
- (b) have inverse time characteristics, matching with transformer over fluxing withstand capability curve
- (c) provide an independent 'alarm' with the time delay continuously adjustable between 0.1 to 6.0 seconds at values of 'v/f' between 100% to 130% of rated values
- (d) tripping time shall be governed by 'v/f' Vs. time characteristics of the relay
- (e) have a set of characteristics for Various time multiplier settings. The maximum operating time of the relay shall not exceed 3 seconds and 1.5 seconds at 'v/f' values of 1.4 and 1.5 times, the rated values, respectively.
- (f) have an accuracy of operating time, better than $\pm 10\%$
- (g) have a resetting ratio of 95 % or better
- ~~(h) be acceptable as a built in feature of other protection IEDs provided for transformer protection~~

- 21.3. **Restricted Earth Fault Protection shall**
- (a) be single pole type
 - ~~(b)~~ be of current/voltage operated ~~high impedance~~ type
 - (c) have a current setting range of 10-40% of 1 Amp./ have a suitable voltage setting range
 - (d) be tuned to the system frequency
- 21.4. **Back-up Over Current and Earth fault protection scheme with high set feature**
- (a) Shall have three over current and one earth fault element(s) which shall be either independent or composite unit(s).
 - (b) The scheme shall include necessary VT fuse failure relays for alarm purposes
 - (c) Over current relay shall
 - have directional IDMT characteristic with a definite minimum time of 3.0 seconds at 10 times setting and have a variable setting range of 50-200% of rated current
 - have low transient, over reach high set instantaneous unit of continuously variable setting range 500-2000 % of rated current
 - have a characteristic angle of 30/45 degree lead
 - include hand reset flag indicators or LEDs.
 - (d) Earth fault relay shall
 - have directional IDMT characteristic with a definite minimum time of 3.0 seconds at 10 times setting and have a variable setting range of 20-80% of rated current
 - have low transient, over reach high set instantaneous unit of continuously variable setting range 200-800 % of rated current
 - have a characteristic angle of 45/60 degree lag
 - include hand reset flag indicators or LEDs
 - include necessary separate interposing voltage transformers or have internal feature in the relay for open delta voltage to the relay
- 21.5. **Transformer Overload Protection Relay shall**
- (a) be of single pole type
 - (b) be of definite time over-current type
 - (c) have one set of over-current relay element, with continuously adjustable setting range of 50-200% of rated current
 - (d) have one adjustable time delay relay for alarm having setting range of 1 to 10.0 seconds, continuously.

- (e) have a drop-off/pick-up ratio greater than 95%.
- (f) ~~be acceptable as built in feature of numerical transformer differential relay~~

21.6. Transformer Neutral Current Protection relay (for 1-Phase transformer bank neutral) shall

- (a) have directional IDMT characteristic with a definite minimum time of 3.0 seconds at 10 times setting and have a variable setting range of 20-80% of rated current
- (b) ~~have low transient, over reach high set instantaneous unit of continuously variable setting range 200-800 % of rated current~~

21.7. Further, Transformer auxiliary protections contacts (Buchholz, PRV, Oil Temperature, Winding Temperature, OLTC Buchholz etc.) can be wired suitably in above protections or provide separate Flag relays/Auxiliary relays as per scheme requirements.

22. TEE DIFFERENTIAL PROTECTION RELAYS

22.1. TEE-1 Differential protection relay shall

- (a) be triple pole type
- (b) have an operating time less than 30 milliseconds at 5 times the rated current
- (c) have three instantaneous high set over current units
- (d) have an adjustable bias setting range of 20-50%
- (e) have an operating current setting of 15% of 1 Amp or less

22.2. TEE-2 Differential Protection relay shall

- (a) be triple pole type
- (b) have operating time less than 25 milliseconds at 5 times setting
- (c) be tuned to system frequency
- (d) have current setting range of 20 to 80% of 1 Amp
- (e) be voltage operated, high impedance type
- (f) be stable for all external faults
- (g) be provided with suitable non linear resistors across the relay to limit the peak voltage to 1000 volts

23. TRIP CIRCUIT SUPERVISION RELAY

- (a) The relay shall be capable of monitoring the healthiness of each 'phase' trip-coil and associated circuit of circuit breaker during 'ON' and 'OFF' conditions.
- (b) The relay shall have adequate contacts for providing connection to alarm and event logger.
- (c) The relay shall have time delay on drop-off of not less than 200 milli seconds and be provided with operation indications for each

phase

24. TRIPPING RELAY

High Speed Tripping Relay shall

- (a) be instantaneous (operating time not to exceed 10 milli-seconds).
- (b) reset within 20 milli seconds
- (c) be D.C. operated
- (d) have adequate contacts to meet the requirement of scheme, other functions like auto-reclose relay, LBB relay as well as cater to associated equipment like event logger, Disturbance recorder, fault Locator, etc.
- (e) be provided with operation indicators for each element/coil.

25. DC SUPPLY SUPERVISION RELAY

- (a) The relay shall be capable of monitoring the failure of D.C. supply to which, it is connected.
- (b) It shall have adequate potential free contacts to meet the scheme requirement.
- (c) The relay shall have a 'time delay on drop-off' of not less than 100 milli seconds and be provided with operation indicator/flag.

26. BUS BAR PROTECTION

26.1. Redundant (1+1) numerical Bus Bar protection scheme for each bus system (Bus1 +Bus2+Transfer Bus wherever applicable) for 400kV and 765kV shall be provided. The scheme shall be engineered so as to ensure that operation of any one out of two schemes connected to main faulty bus shall result in tripping of the same.

26.2. Single bus bar protection scheme shall be provided for each main bus and transfer bus (as applicable) for 220KV and 132 KV voltage levels

26.3. Each Bus Bar protection scheme shall

- (a) have maximum operating time up to trip impulse to trip relay for all types of faults of 25 milli seconds at 5 times setting value.
- (b) operate selectively for each bus bar
- (c) give hundred percent security up to 63 KA fault level for 400KV and 220KV and 31.5 KA for 132 KV
- (d) incorporate continuous supervision for CT secondary against any possible open circuit and if it occurs, shall render the relevant zone of protection inoperative and initiate an alarm
- (e) not give false operation during normal load flow in bus bars
- (f) incorporate clear zone indication
- (g) be of phase segregated and triple pole type
- (h) provide independent zones of protection (including transfer bus if any). If the bus section is provided then each side of bus section shall have separate set of bus bar protection schemes

- (i) include individual high speed electrically reset tripping relays for each feeder. However, in case of distributed Bus bar protection, individual trip relay shall not be required if bay unit is having trip duty contacts for breaker tripping.
- (j) be transient free in operation
- (k) include continuous D.C. supplies supervision
- (l) not cause tripping for the differential current below the load current of heaviest loaded feeder. ~~Contractor~~ Bidder shall submit application check for the same.
- (m) shall include necessary C.T. switching relays wherever C.T. switching is involved and have 'CT' selection incomplete alarm
- (n) include protection 'IN/OUT' switch for each zone
- (o) shall include trip relays, CT switching relays (if applicable), auxiliary CTs (if applicable) as well as additional power supply modules, input modules etc. as may be required to provide a Bus-bar protection scheme for the complete bus arrangement i.e. for all the bays or breakers including future bays as per the Single line diagram for new substations. However for extension of bus bar protection scheme in existing substations, scope shall be limited to the bay or breakers covered under this specification. Suitable panels (if required) to mount these are also included in the scope of the work.
- (p) In case of distributed Bus bar Protection, the bay units for future bays may be installed in a separate panel and the same shall be located in switchyard panel room where bus bar protection panel shall be installed.

26.4. Built-in Local Breaker Backup protection feature as a part of bus bar protection scheme shall also be acceptable.

26.5. At existing substations, Bus-bar protection scheme with independent zones for each bus, will be available. All necessary co-ordination for 'AC' and 'DC' interconnections between existing schemes (Panels) and the bays proposed under the scope of this contract shall be fully covered by the bidder. Any auxiliary relay, trip relay, flag relay and multi tap auxiliary CTs (in case of biased differential protection) required to facilitate the operation of the bays covered under this contract shall be fully covered in the scope of the bidder..

26.6. The test terminal blocks (TTB) to be provided shall be fully enclosed with removable covers and made of moulded, non-inflammable plastic material with boxes and barriers moulded integrally. All terminals shall be clearly marked with identification numbers or letters to facilitate connection to external wiring. Terminal block shall have shorting, disconnecting and testing facilities for CT circuits.

27. WEATHER PROOF RELAY PANELS (If Applicable)

- (a) This panel shall include necessary number of electrically reset

relays each with at least eight contacts for isolator auxiliary contacts multiplication and for changing the CT and DC circuits to relevant zones of bus bar protection.

- (b) The panel shall be sheet steel enclosed and shall be dust, weather and vermin proof. Sheet steel used shall be at least 2.0 mm thick and properly braced to prevent wobbling.
- (c) The enclosures of the panel shall provide a degree of protection of not less than IP-55 (as per IS: 2147).
- (d) The panel shall be of free standing floor mounting type or pedestal mounting type as per requirement.
- (e) The panel shall be provided with double hinged doors with padlocking arrangement.
- (f) All doors, removable covers and panels shall be gasketed all around with synthetic ~~rubber~~ gaskets Neoprene/EPDM generally conforming with provision of IS 11149. However, XLPE gaskets can also be used for fixing protective glass doors. Ventilating louvers, if provided shall have screens and filters. The screens shall be made of either brass or GI wire mesh
- (g) Cable entries shall be from bottom. Suitable removable cable gland plate shall be provided on the cabinet for this purpose.
- (h) All sheet steel work shall be degreased, pickled, phosphated and then applied with two coats of zinc chromates primer and two coats of finishing synthetic enamel paint, both inside and outside. The colour of the finishing paint shall be light grey in accordance with shade no.697 of IS: 5.
- (i) Suitable heaters shall be mounted in the panel to prevent condensation. Heaters shall be controlled by thermostats so that the cubicle temperature does not exceed 30°C. On-off switch and fuse shall be provided. Heater shall be suitable for 240V AC supply Voltage.
- (j) The test terminal blocks (TTB) to be provided shall be fully enclosed with removable covers and made of moulded, non-flammable plastic material with boxes and barriers moulded integrally. All terminals shall be clearly marked with identification numbers or letters to facilitate connection to external wiring. Terminal block shall have shorting, disconnecting and testing facilities for CT circuits.

28. FAULT RECORDER

- 28.1. The fault recorder shall be provided for transmission line and the fault recorder as in-built feature of line distance relay is also acceptable provided the requirements of following clauses are met.
- 28.2. Fault recorder shall be microprocessor based and shall be used to record the graphic form of instantaneous values of voltage and current in all three phases, open delta voltage & neutral current, open or closed position of relay contacts and breakers during the system disturbances.

- 28.3. The Fault recorder shall consist of individual acquisition units, one for each feeder and an Evaluation unit which is common for the entire Substation. Whenever, more than one acquisition units are connected to an Evaluation unit, necessary hardware and software shall also be supplied for on line transfer of data from all acquisition units to Evaluation unit.
- 28.4. The acquisition unit is connected with evaluation unit being supplied as described in section sub-station automation through bus conforming to IEC 61850. In case of extension sub-station which is equipped with Sub-station Automation System based on IEC 61850, one set of evaluation software shall be supplied and loaded in existing fault recorder evaluation unit. Automatic uploading of disturbance files from acquisition unit to evaluation unit shall be done through existing station bus only conforming to IEC 61850. Necessary configuration/update including hardware if any shall be in the scope of the ~~contractor~~: Bidder.
- 28.5. In case of extension of existing substation(s) which are without sub-station automation system, one set of Evaluation unit shall be supplied for each substation where ever disturbance recorders are required to be supplied along with necessary evaluation software as specified above. The Evaluation unit shall consist of a desktop personal computer (including at least 17" TFT colour monitor, mouse and keyboard) and printer. The desktop PC shall have Pentium - IV processor or better and having a clock speed 3.0GHz or better. The hard disk capacity of PC shall not be less than 300 GB and RAM capacity shall not be less than 3 GB
- 28.6. The evaluation unit hardware, for substations having SAS, shall be as described in clause no. 4.0 of section sub-station automation system.
- 28.7. Fault recorder shall have atleast 8 analogue and 16 digital channels for each feeder.
- 28.8. Acquisition units shall acquire the Disturbance data for the pre fault and post fault period and transfer them to Evaluation unit automatically to store in the hard disk. The acquisition units shall be located in the protection panels of the respective feeders.
- 28.9. The acquisition unit shall be suitable for inputs from current transformers with 1A rated secondary and capacitive voltage transformers with 63.5V (phase to neutral voltage) rated secondary. Any device required for processing of input signals in order to make the signals compatible to the Fault recorder equipment shall form an integral part of it. However, such processing of input signals shall in no way distort its waveform.
- 28.10. The equipment shall be carefully screened, shielded, earthed and protected as may be required for its safe functioning. Also, the Fault recorder shall have stable software, reliable hardware, simplicity of maintenance and immunity from the effects of the hostile environment of EHV switchyard which are prone to various interference signals typically from large switching transients.
- 28.11. Necessary software for transferring the data automatically from local evaluation unit to a remote station and receiving the same at the remote

station through owner's PLCC/VSAT/LEASED LINE shall be provided.

- 28.12. Evaluation software shall be provided for the analysis and evaluation of the recorded data made available in the PC under DOS/WINDOWS environment. The Software features shall include repositioning of analog and digital signals, selection and amplification of time and amplitude scales of each analogue and digital channel, calculation of MAX/MIN frequency, phase difference values, recording of MAX/MIN values etc. of analogue channel, group of signal to be drawn on the same axis etc, listing and numbering of all analogue and digital channels and current, voltage, frequency and phase difference values at the time of fault/tripping. Also, the software should be capable of carrying out Fourier /Harmonic analysis of the current and voltage wave forms. The Disturbance records shall also be available in COMTRADE format (IEEE standard- Common Format for Transient data Exchange for Power System)
- 28.13. The Evaluation unit shall be connected to the printer to obtain the graphic form of disturbances whenever desired by the operator.
- 28.14. Fault recorder acquisition units shall be suitable to operate from 220V DC or 110V DC as available at sub-station. Evaluation unit along with the printer shall normally be connected to 230V, single phase AC supply. In case of failure of AC supply, Evaluation unit and printer shall be switched automatically to the station DC through Inverter of adequate capacity which shall form a part of Fault recorder system. The inverter of adequate capacity shall be provided to cater the requirement specified in section sub-station automation clause no. 8.0 and DR evaluation unit.
- 28.15. The acquisition unit shall have the following features
- (a) Facility shall exist to alarm operator in case of any internal faults in the acquisition units such as power supply fail, processor / memory fail etc and same shall be wired to annunciation system.
 - (b) The frequency response shall be 5 Hz on lower side and 250 Hz or better on upper side.
 - (c) Scan rate shall be 1000 Hz/channel or better.
 - (d) Pre-fault time shall not be less than 100 milliseconds and the post fault time shall not be less than 2 seconds (adjustable). If another system fault occurs during one post-fault run time, the recorder shall also be able to record the same. However, the total memory of acquisition unit shall not be less than 5.0 seconds
 - (e) The open delta voltage and neutral current shall be derived either through software or externally by providing necessary auxiliary transformers.
 - (f) The acquisition unit shall be typically used to record the following digital channels :
 - 1 Main CB R phase open
 - 2 Main CB Y phase open
 - 3 Main CB B phase open

- 4 Main-1 carrier received
- 5 Main-1 protection operated
- 6 Main/Tie /TBC Auto reclosed operated
- 7 Over Voltage -Stage-1 /2 operated
- 8 Reactor / Stub/TEE-1/2/UF protection operated
- 9 Direct Trip received
- 10 Main-2 carrier received
- 11 Main- 2/ Back Up protection operated
- 12 Bus bar protection operated
- 13 LBB operated of main /tie/TBC circuit breaker
- 14 Tie/TBC CB R phase open
- 15 Tie/TBC CB Y phase open
- 16 Tie/TBC CB B phase open

- (g) In case the Fault recorder is in-built part of line distance protection, above digital channels may be interfaced either externally or internally.
- (h) Any digital signal can be programmed to act as trigger for the acquisition unit. Analog channels should have programmable threshold levels for triggers and selection for over or under levels should be possible.

28.16. The colour laser printer shall be provided which shall be compatible with the desktop PC and shall use Plain paper. The print out shall contain the Feeder identity, Date and time (in hour, minute and second up to 100th of a second), identity of trigger source and Graphic form of analogue and digital signals of all the channels. Two packets of A4 size paper (500 sheets in each packet) suitable for printer shall be supplied.

28.17. Each Fault recorder shall have its own time generator and the clock of the time generator shall be such that the drift is limited to ± 0.5 seconds/day, if allowed to run without synchronisation. Further, Fault recorder shall have facility to synchronise its time generator from Time Synchronisation Equipment having output of following types

- Voltage signal : (0-5V continuously settable, with 50m Sec. minimum pulse duration)
- Potential free contact (Minimum pulse duration of 50 m Sec.)
- IRIG-B
- RS232C

The recorder shall give annunciation in case of absence of synchronising within a specified time.

28.18. Substations where Time Synchronisation Equipment is not available, time generator of any one of the Fault recorders can be taken as master and time generators of other Fault recorders and Event loggers in that

station shall be synchronised to follow the master.

29. DISTURBANCE RECORDER (for 765 KV Feeders only)

A separate numerical disturbance recording function shall be provided for each 765kV lines. The following requirements shall be met:

29.1. The disturbance recorder shall record the analogue values form of the instantaneous values of voltage and current in all three phases, the open delta voltage and the neutral current. The open or closed position of relay contacts and circuit breakers during system disturbances shall also be recorded.

29.2. The disturbance recorder shall comprise distributed individual acquisition units, one for each feeder and an evaluation unit which is common for the entire substation. The acquisition units shall acquire the disturbance data for the pre-fault, fault and post-fault periods and transfer them to the evaluation unit automatically for storage on a mass storage device. The acquisition unit shall be suitable for inputs from current transformers with 1 A rated secondaries and capacitive voltage transformers with 63.5 V (phase-to-neutral voltage) rated secondaries.

29.3. The acquisition units shall have the following features:

- (a) A facility to alert the operator in the case of any internal faults (such as power supply fail, processor/memory fail etc.) in any of the acquisition units and this alarm shall be wired to the station annunciation system.
- (b) The pre-fault time shall not be less than 200 milliseconds and the post fault time shall not be less than 2 seconds (adjustable). If another system disturbance occurs during a post-fault run time, the recorder shall also be able to record this subsequent disturbance. The scan rate should be selectable in the range from 1000 Hz to 5000 Hz.
- (c) The open delta voltage and neutral current shall be derived either through software or externally by providing necessary auxiliary transformers.
- (d) The acquisition unit shall be typically used to record the following digital channels:
 - 1. Main circuit-breaker R-phase open
 - 2. Main circuit-breaker Y-phase open
 - 3. Main circuit-breaker B-phase open
 - 4. Main 1 carrier received
 - 5. Main 1 protection operated
 - 6. Main/Tie auto-reclose operated
 - 7. Overvoltage stage 1/2 operated
 - 8. Reactor/Stub-1/2 protection operated
 - 9. Direct trip received

10. Main 2 carrier received
11. Main 2 protection operated
12. Busbar protection operated
13. Breaker failure protection of main/tie circuit-breaker operated
14. Tie circuit-breaker R-phase open
15. Tie circuit-breaker Y-phase open
16. Tie circuit-breaker B-phase open

29.4. The necessary hardware and software shall also be supplied for the on-line transfer of data from all acquisition units to the evaluation unit. The disturbance recording system shall be capable of handling the full complement of feeders in the substation.

29.5. The disturbance recording equipment shall be screened, shielded, earthed and protected as may be required for its safe and proper functioning. Also, the disturbance recorder shall have stable software, reliable hardware, simplicity of maintenance and immunity from the effects of the hostile environment of a 765 kV EHV switchyard which is prone to numerous interference signals such as large switching transients.

29.6. The evaluation unit shall comprise all the necessary hardware and software for the proper evaluation of disturbances. The hardware would typically consist of a desktop personal computer (including a large high resolution colour monitor, mouse and keyboard) and a high-speed colour printer. The desktop PC shall have Pentium P4 processor or better and shall have a clock speed of 1600 MHz or better. The mass storage capacity of PC shall not be less than 32 GB and the RAM capacity shall not be less than 1 GB. The evaluation software required for the analysis and evaluation of the recorded data shall run on the PC under Microsoft Windows environment. The software features shall provide:

- clear and unambiguous display of all channels;
- the ability to reposition the analog and digital traces;
- recording of maximum/minimum values etc. of the analog channels;
- calculation of maximum/minimum frequency and phase difference values;
- grouping of signals for drawing on the same axis;
- listing and identification of all analog and digital channels as well as and current, voltage, frequency and phase difference values at the time of fault/tripping;
- the capability of carrying out Fourier/Harmonic analysis of the current and voltage waveforms; and,
- the availability of the disturbance records in COMTRADE format

- 29.7. The evaluation unit shall be permanently connected to the printer so as to obtain the graphic display of disturbances whenever desired by the operator. The printer shall be compatible with the desktop PC and shall use plain paper. The print out shall contain the feeder identity, date and time (in hour, minute and second up to 100th of a second), identity of the trigger source and graphic representation of the analog and digital signals of all the channels.
- 29.8. The disturbance recorder acquisition units shall be suitable to operate from the station DC. The evaluation unit along and the printer shall normally be connected to the 230 V, single phase AC supply. In the case of a failure of the AC supply, the evaluation unit and printer shall be automatically switched to the station DC through an inverter of adequate capacity and which shall form part of disturbance recording system.
- 29.9. The disturbance recorder shall be capable of being triggered by the following user-specified quantities:
- (a) external start, both software and hardware
 - (b) cross triggering of groups of channels, either software or hardware or both
 - (c) binary channel (NO and NC contacts)
 - (d) over voltage and under voltage
 - (e) over current
 - (f) negative sequence voltage
 - (g) zero sequence voltage
 - (h) rate of change, voltage or current
 - (i) over frequency or under frequency
 - (j) logical or Boolean expressions, programmable
 - (k) power swing
 - (l) rate of change of active or reactive power
- 29.10. The disturbance recorder shall have its own time generator and the clock of the time generator shall be such that the drift is limited to less than ± 0.5 seconds per day, if allowed to run without synchronisation. Further, the disturbance recorder shall have the facility to synchronise its time generator from the station Time Synchronisation Equipment using IRIG-B. The recorder shall give an alarm in the case of the absence of the synchronising pulse for a pre-determined time.
30. **DISTANCE TO FAULT LOCATOR** shall
- a) be electronic or microprocessor based type
 - b) be 'On-line' type
 - c) be suitable for breaker operating time of 2 cycles
 - d) have built-in display unit
 - e) the display shall be directly in percent of line length or kilometres without requiring any further calculations

- f) have an accuracy of 3% or better for the typical conditions defined for operating timings measurement of distance relays
- g) The above accuracy should not be impaired under the following conditions:
 - presence of remote end infeed
 - predominant D.C. component in fault current
 - high fault arc resistance
 - severe CVT transients
- h) shall have mutual zero sequence compensation unit if fault locator is to be used on double circuit transmission line
- i) built in feature of line distance relay is acceptable provided the requirements of above clauses are met

31. TIME SYNCHRONISATION EQUIPMENT

- 31.1. The Time synchronisation equipment shall receive the co-ordinated Universal Time (UTC) transmitted through Geo Positioning Satellite System (GPS) and synchronise equipments to the Indian Standard Time in a substation.
- 31.2. Time synchronisation equipment shall include antenna, all special cables and processing equipment etc.
- 31.3. It shall be compatible for synchronisation of Event Loggers, Disturbance recorders and SCADA at a substation through individual port or through Ethernet realised through optic fibre bus.
- 31.4. Equipment shall operate up to the ambient temperature of 50 degree centigrade and 80% humidity.
- 31.5. The synchronisation equipment shall have 2 micro-second accuracy, Equipment shall give real time corresponding to IST (taking into consideration all factors like voltage, & temperature variations, propagation & processing delays etc).
- 31.6. Equipment shall meet the requirement of IEC 60255 for storage & operation.
- 31.7. The system shall be able to track the satellites to ensure no interruption of synchronisation signal.
- 31.8. The output signal from each port shall be programmable at site for either one hour, half hour, minute or second pulse, as per requirement.
- 31.9. The equipment offered shall have six (6) output ports. Various combinations of output ports shall be selected by the customer, during detailed engineering, from the following :
 - Potential free contact (Minimum pulse duration of 50 milli Seconds.)
 - IRIG-B
 - RS232C

- SNTP Port

- 31.10. The equipment shall have a periodic time correction facility of one second periodicity.
- 31.11. Time synchronisation equipment shall be suitable to operate from 220V DC or 110V DC as available at Substation.
- 31.12. Equipment shall have real time digital display in hour, minute, second (24 hour mode) & have a separate time display unit to be mounted on the top of control panels having display size of approx. 100 mm height.

32. RELAY TEST KIT

- 32.1. One relay test kit shall comprise of the following equipment as detailed here under

- 3 sets Relay tools kits
- 2 nos. Test plugs for TTB
- + 2 nos. . . . ~~Special type~~ Test plugs for using with modular type relays (if applicable)

33. TYPE TESTS

- 33.1. The reports for following type tests shall be submitted during detailed engineering for the Protective relays, Fault Recorder, Fault locator and Disturbance recorder:

- a) Insulation tests as per IEC 60255-5
- b) DC Voltage dips and interruptions/Variation as per IEC 6100-4-29.
- c) High frequency disturbance test as per IEC 61000-4 16, Class IV (Not applicable for electromechanical relays)
- d) Electrostatic discharges as per IEC 61000-4-2, level; 4 (not applicable for Electromechanical relays)
- e) Fast transient test as per IEC 61000-4-4, Level IV (Not applicable for electromechanical relays)
- f) Relay characteristics, performance and accuracy test as per IEC 60255
 - Steady state Characteristics and operating time
 - Dynamic Characteristics and operating time for distance protection relays and current differential protection relays
 - Conformance test as per IEC 61850-10.

For Fault recorder, Disturbance recorder; only performance tests are intended under this item.

- g) Tests for thermal and mechanical requirements as per IEC 60255-6
- h) Tests for rated burden as per IEC 60255-6
- i) Contact performance test as per IEC 60255-0-20 (not applicable for Distance to fault locator and Disturbance recorder)

In case there is a change either in version or in model (Except firmware)

of the relay, the ^{Bidder} contractor has to submit the type test reports for the offered revision/model.

- 33.2. Steady state & Dynamic characteristics test reports on the distance protection relays, as type test, shall be based on test programme specified in Appendix A on simulator/network analyser/PTL. Alternatively, the files generated using Electromagnetic transient Programme (EMTP) can also be used for carrying out the above tests. Single source dynamic tests on transformer differential relay shall be/ should have been conducted based on general guidelines specified in CIGRE committee 34 report on Evaluation of characteristics and performance of Power system protection relays and protective systems.

34. CONFIGURATION OF RELAY AND PROTECTION PANELS

The following is the general criteria for the selection of the equipments to be provided in each type of panel. However, ^{Bidder} contractor can optimise the requirement of panels by suitably clubbing the feeder protection and CB relay panels. It may be noted that Main-I and Main-II protections for line can not be provided in single panel. Similarly, Group-I & Group-II protections for transformer can not be provided in single panel.

CONTROL PANEL

Various types of control panels shall consist of the following

| | | | |
|---|------------------------------|-------|---|
| a | Ammeter | 3 set | for each Line, BC, TBC Bus section , Bus Reactor and Transformer |
| b | Ammeter with Selector switch | 1 set | for each line reactor |
| c | Wattmeter with transducer | 1 set | for each line, transformer |
| d | Varmeter with transducer | 1 set | for each line, transformer, Bus reactor |
| e | Varmeter with transducer | 1 set | for each Line Reactor |
| f | CB Control switch | 1 no. | for each Circuit breaker |
| g | Isolator Control switch | 1 no. | for each isolator |
| h | Semaphore | 1 no. | for each earth switch |
| i | Red indicating lamp | 1 no. | for each Circuit breaker |
| j | Red indicating lamp | 1 no. | for each isolator |
| k | Green indicating lamp | 1 no. | for each Circuit breaker |
| l | Green indicating lamp | 1 no. | for each isolator |

| | | | |
|---|---|--------|---|
| m | White indicating lamp (DC healthy lamp) | 2 nos | for each feeder |
| n | Annunciation windows with associated annunciation relays | 18 nos | for each feeder |
| o | Push button for alarm Accept/reset/lamp test | 3 nos | for each control panel |
| p | Synchronising Socket | 1 no. | for each Circuit Breaker if required |
| q | Synchronising selector Switch | 1 no. | for each Circuit Breaker switch if required |
| r | Protection Transfer Switch | 1 no. | for each breaker in case of DMT /DM*/SMT schemes (Except TBC and BC breaker) - * with by pass isolator |
| s | Mimic to represent SLD | Lot | in all control panels |
| t | Voltmeter with selector Switch | 1 no | for each line, transformer , bus reactor |
| u | Cut out, mounting and wiring for RWTI and selector switch | Lot | for transformers/reactors |

Notes:

- 1 For transformer feeders, all equipments of control panel shall be provided separately for HV and MV sides.
2. In case of incomplete diameter (D and I type layouts), control panel shall be equipped fully as if the diameter is complete, unless otherwise specified. Annunciation relays shall also be provided for the same and if required, necessary panel shall be supplied to accommodate the same.
3. The above list of equipments mentioned for control panel is generally applicable unless it is defined elsewhere and in case of bay extension in existing substations, necessary equipments for matching the existing control panel shall be supplied.
4. Common synchronising switch is also acceptable in Synchronising trolley for new Substations. In this case, individual synchronising selector switch is not required for each Circuit Breaker in control panel
5. Each line /HV side of transformer/MV/LV side of transformer /Bus reactor /TBC /BC/ Bus Section shall be considered as one feeder for above purpose.

LINE PROTECTION PANEL

The Line Protection panel for transmission lines shall consist of following protection features/schemes

| SI. No. | Description | 765/400kV | 220kV | 132kV |
|---------|---|-------------|-------------|-------------|
| 1. | Main-1 Numerical Distance protection scheme | 1 Set | 1 Set | 1 Set |
| 2. | Main-2 Numerical Distance protection scheme | 1 Set | 1 Set | NIL |
| 3. | Over Voltage Protection Scheme | 1 Set | NIL | NIL |
| 4. | Fault Recorder | 1 Set | 1 Set | NIL |
| 5. | Disturbance Recorder* | 1 Set | NIL | NIL |
| 6. | Distance to fault Locator | 1 Set | 1 Set | 1 Set |
| 7. | 3 Phase Trip Relays | 2 Nos. | 2 Nos. | 2 Nos. |
| 8. | Flag relays, carrier receive relays, aux. Relays, timers etc as per scheme requirements | As required | As required | As required |
| 9. | Under Voltage protection relay for isolator/earth switch | 2 Nos | 2 Nos | 2 Nos |
| 10. | Cut-out and wiring with TTB for POWERGRID supplied energy meter | 1 Set | 1 Set | 1 Set |
| 11. | Directional Back up Over current and E/F protection scheme | NIL | NIL | 1 Set |

* Applicable for 765kV Lines Only

In a substation where 765kV, 400kV and 220 KV lines are under the scope of the contract, bidder is required to give identical Main-1 and Main-2 distance protection schemes for all voltage levels.

TRANSFORMER PROTECTION PANEL

The protection panel for Auto transformer/Transformer shall consists of the following features/schemes:

| Sl. No. | Description | HV side | MV/LV side |
|---------|--|---------|--|
| 1. | Transformer Differential Protection scheme | 1 Nos. | Nil |
| 2. | Restricted Earth fault protection scheme | 1 no. | 1 no@ |
| | | | @ Not applicable for auto-transformer |
| 3. | Directional back up O/C and E/F relay with non directional high set feature | 1 set | 1 set |
| 4. | Over Fluxing Protection scheme | 1 no. | 1 no.\$ |
| | | | \$ Applicable only for 400/220kV Transformer & 765/400 Transformer |
| 5. | Overload protection scheme | 1 nos. | NIL |
| 6. | Three phase trip relays | 2 nos. | 2 nos. |
| 7. | CVT selection relays as per scheme requirement | Lot | Lot |
| 8. | Cut-out and wiring with TTB for POWERGRID supplied energy meter | 1 set | 1 set |
| 9. | Transformer Neutral Current relay for 1-Phase transformer bank | | 1 Set |
| 10. | Flag Relays/Aux. Relays for wiring Transformer auxiliary protection contacts such as Buchholz, Oil Temperature, Winding Temperature, PRV, OLTC Buchholz etc. as per scheme requirements | | As required |

The above protection schemes may be clubbed in Group-I/II as per clause no. 21 of technical specification.

REACTOR PROTECTION PANEL

The protection panel for Reactor shall consist of the following protection features/schemes:

| Sl. No. | Description | Qty. |
|---------|---|--------------------|
| 1. | Reactor Differential Protection scheme | 1 no. |
| 2. | Restricted Earth fault Protection scheme | 1 no. |
| 3. | Reactor back up impedance protection scheme | 1 set |
| 4. | Three phase trip relays | 2 nos. |
| 5. | CVT selection relay as per scheme requirement | Lot |
| 6. | Flag Relays/Aux. Relays for wiring Reactor auxiliary protection contacts such as Buchholz, Oil Temperature, Winding Temperature, PRV etc. as per scheme requirements | As required |
| 7. | Feed protection relay (only for 765kV bus reactor) | 1 no. |

BREAKER RELAY PANEL

The breaker relay panel shall comprise of the following:

| Sl. No. | Description | With A/R | With out A/R |
|---------|--|-------------|--------------|
| 1. | Breaker failure Protection Scheme | 1 No. | 1 No. |
| 2. | DC supply Supervision relay | 2 Nos. | 2 Nos. |
| 3. | Trip Circuit supervision relays# | 6 Nos. | 6 Nos. |
| 4. | Auto-reclose scheme with check synchronising and dead line charging relay (if standalone) | 1 Nos. | NIL |
| 5. | Flag relays, aux relays, timers, trip relays as per scheme requirements | As required | As required |

Trip supervision relays shall be 2 or 6 numbers as per no. of trip coils for each 132KV Circuit breaker

Note: Equipment/relays to be provided under CB Relay Panel may be accommodated in the Protection Panels to be provided for Transmission Line/Transformer/Reactor as applicable.

35. ERECTION AND MAINTENANCE TOOL EQUIPMENTS

All special testing equipment required for the installation and maintenance of the apparatus, instruments devices shall be furnished in relevant schedule

36. TROPICALISATION

Control room will be normally air-cooled/air-conditioned. All equipments shall however be suitable for installation in a tropical monsoon area having hot, humid climate and dry and dusty seasons with ambient conditions specified in the specification. All control wiring, equipment and accessories shall be protected against fungus growth, condensation, vermin and other harmful effects due to tropical environment.

37. MONITORING, CONTROL & PROTECTION FOR AUXILIARY TRANSFORMER

Suitable monitoring, control (operation of associated circuit breaker & isolator) and protection for 630/800/1000KVA transformer, connected to tertiary winding of auto transformer for the purpose of auxiliary supply shall be provided by the contractor. Over current and open delta protection is required to be provided for the auxiliary transformer. These protection and control shall be also be acceptable as built in feature either in the bay controller to be provided for the auxiliary system or in the control & protection IEDs to be provided for autotransformer.

Test programme for distance relays

General Comments:

1. These test cases are evolved from the report of working group 04 of study committee 34 (Protection) on evaluation of characteristics and performance of power system protection relays and protective systems. For any further guidelines required for carrying out the tests, reference may be made to the above document.
2. The test shall be carried out using network configuration and system parameters as shown in the figure-1
3. All denotations regarding fault location, breakers etc are referred in figure –1
4. The fault inception angles are referred to R- N voltage for all types of faults
5. The fault inception angle is zero degree unless otherwise specified
6. Where not stated specifically, the fault resistance (R_f) shall be zero or minimum as possible in simulator
7. Single pole circuit breakers are to be used
8. The power flow in double source test is 500 MW

System parameters

System voltage =400KV

CTR= 1000/1

PTR = 400000/110 (with CVT, the parameters of CVT model are shown in figure –2)

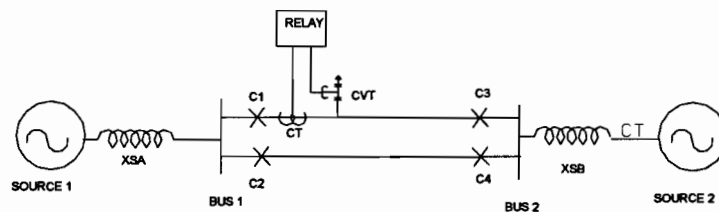

- FIGURE 1

Line parameters/km

Positive Sequence Resistance, (r_1) = 0.02897 Ω

| | |
|--------------------------------------|---------------|
| Positive Sequence Reactance (x1) | = 0.3072 Ω |
| Zero Sequence Resistance (r0) | = 0.2597 Ω |
| Zero Sequence Reactance (x1) | = 1.0223 Ω |
| Zero Sequence Mutual Resistance (rm) | = 0.2281 Ω |
| Zero Sequence Mutual Reactance (xm) | = 0.6221 Ω |
| Zero Sequence susceptance (bo) | = 2.347 μ mho |
| Positive Sequence susceptance (b1) | = 3.630 μ mho |

| Type of line | Short | | Long |
|--|-----------------------|------------------------|----------------------|
| Secondary line impedance | 2 Ω | | 20 Ω* |
| Length of line in Kms | 23.57 | | 235.7 |
| SIR | 4 | 15 | 4 |
| Source impedance (pry) (at a time constant of 50 ms) | 29.09 Ω (5500 MVA) | 109.09 Ω (1467 MVA) | 290.9 Ω (550 MVA) |

* Alternatively , the tests can be done with 10 Ω secondary impedance and source impedance may accordingly be modified

CVT Model

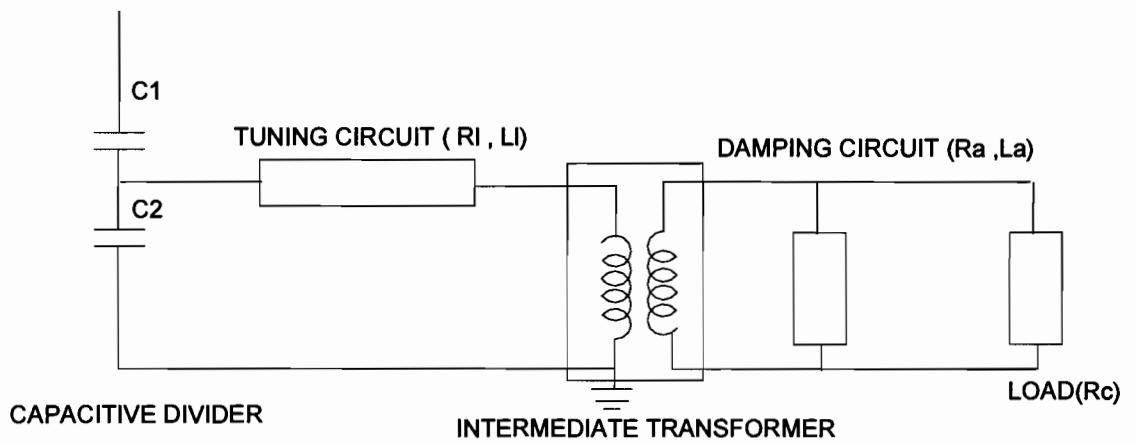

Figure-2

| | |
|-----|--------------|
| XC1 | 1.455 μ mho |
| XC2 | 27.646 μ mho |

| | |
|--|-----------------|
| RI | 320 Ω |
| XLI | 34243 Ω |
| Ra | 4.200 Ω |
| Xla | 197.92 Ω |
| Rc | 14.00 Ω |
| Transformation ratio of Intermediate transformer | 181.8 |

Details of fault cases to be done

| S n o | Description | Single source with short line (2 Ω) | | Single source long line (20 Ω) | Double source with short double line (2 Ω) | Double source with long single line (20 Ω) |
|-------------|-------------------------------------|---|--|--|--|---|
| | | | | | | |
| | | CLOSE C1, OPEN C2,C3,C4 | | CLOSE C1, OPEN C2,C3,C4 | CLOSE C1, C2,C3,C4 | CLOSE C1,C3 OPEN C2,C4 |
| | | SIR=4 | SIR=15 | SIR =4 | SIR = 4 | SIR=4 |
| 1 | Dynamic accuracy for zone 1 | Tests to be done at 2 locations (84 % and 76 % of line length) X 4 faults (RN , YB, YBN, RYB) X 2 fault inception angle (0°, 90°)= 16 cases | Tests to be done at 2 locations (84 % and 76 % of line length) X 4 faults (RN , YB, YBN, RYB) X 2 fault inception angle (0°,90°)= 16 cases | Tests to be done at 2 locations (84 % and 76 % of line length) X 4 faults (RN , YB, YBN, RYB) X 2 fault inception angle (0°,90°)= 16 cases | | Tests to be done at 2 locations (84% and 76% of line length) X 4 faults (RN , YB, YBN, RYB) X 2 fault inception angle (0°, 90°)= 16 cases |
| 2 | Operating time for zone 1 at SIR =4 | Tests to be done at 3 locations (0% , 40% and 64% of line length) X 4 faults (RN, YB, YBN, RYB) X 4 fault inception | Tests to be done at 3 locations (0 % , 40 % and 64 % of line length) X 4 faults (RN , YB, YBN, RYB) X 4 fault inception | Tests to be done at 3 locations (0 % , 40 % and 64 % of line length) X 4 faults (RN , YB, YBN, RYB) X 4 fault | Tests to be done at 1 location (40 % of line length) X 4 faults (RN, YB, YBN, RYB) X 4 fault inception angle | Tests to be done at 1 location (40 % of line length) X 4 faults (RN, YB, YBN, RYB) X 4 fault inception angle (0°,30°,60° |

| SI no | Description | Single source with short line (2 Ω) | | Single source long line (20 Ω) | Double source with short double line (2 Ω) | Double source with long single line (20 Ω) |
|----------|--|---|--|---|--|---|
| | | angle (0°, 30°,60° and 90°) = 48 cases | angle (0°,30°,60°an d 90°)= 48 cases | inception angle (0°, 30°,60° and 90°)= 48 cases | (0°,30°,60° and 90 °)= 16 cases | and 90°)= 16cases |
| 3 | Operating time for zone II and Zone III | Tests to be done at 1 location (100 % of line length) X 1 faults (RN, YB, YBN, RYB) X 2 zones (II and III) = 2 cases | Tests to be done at 1 location (100 % of line length) X 1 faults (RN , YB, YBN, RYB) X 2 zones (II and III) = 2 cases | Tests to be done at 1 location (100 % of line length) X 1 faults (RN , YB, YBN, RYB) X 2 Zones (II and III) = 2 cases | | |
| 4 | Switch on to fault feature | | | Tests to be done at 2 location (0 % and 32 %) X 1 faults (RYB) Any fault inception angle = 2 cases | | |
| 5 | Operation during current reversal | | | | Tests to be done at 2 location (0 % and 80 % of line length) X 1 faults (RN) X 1 fault inception angle (0 degrees) = 2 cases | |
| | | CLOSE C1, OPEN C2,C3,C4 | | CLOSE C1, OPEN C2,C3,C4 | CLOSE C1, C2,C3,C4 | CLOSE C1,C3 OPEN C2,C4 |
| | | SIR=4 | SIR=15 | SIR =4 | SIR = 4 | SIR=4 |
| 6 | Operation at simultaneou | | | | Tests to be done at 2 | |

| S I n o | Description | Single source with short line (2 Ω) | | Single source long line (20 Ω) | Double source with short double line (2 Ω) | Double source with long single line (20 Ω) |
|------------------|------------------------------------|--|--|--------------------------------------|---|--|
| | s faults | | | | location (8 % and 64 % of line length) X 2 faults (RN in circuit 1 to BN in circuit 2 and RN in circuit 1 to RYN in circuit 2 in 10 ms) X 1 fault inception angle (0 °) = 4 cases (*1) | |
| 7 | Directional sensitivity | | | | | Tests to be done at 1 location (0% reverse) X 6 faults (RN ,YB, YBN , RYB,RN with Rf=13.75 ohm(sec) and RYN with Rf= 13.75 Ohm (sec) X 2 fault inception angle (0° ,90°) = 12cases |
| 8 | Limit for fault resistance | | | | | Tests to be done at 2 location (0% and 68 % of line length) X 1 fault (RN with Rf=13.75 ohm(sec) X 2 fault inception angle (0°,90°) = 4 cases |
| 9 | Operation at evolving faults | | | | | Tests to be done at 2 location (32 % and 0% of line |

| S I n o | Description | Single source with short line (2 Ω) | | Single source long line (20 Ω) | Double source with short double line (2 Ω) | Double source with long single line (20 Ω) |
|------------------|--|---|--|--|---|--|
| | | | | | | length) X 2 faults (RN to RYN) x in 2 timings (10 ms and 30 ms) X 2 load direction (from A to B and from B to A) = 16 cases |
| 9 | Fault locator function , in case the same is offered as built in feature | Measure fault location for all cases under 1 and 2 | Measure fault location for all cases under 1 and 2 | Measure fault location for all cases under 1 and 2 | Measure fault location for all cases under 2 and 6 | Measure fault location for all cases under 2, 7 and 9 |

ANNEXURE - A

SECTION - II

SECTION: SUBSTATION AUTOMATION SYSTEM

1.0 GENERAL

1.1. ~~The substation automation system shall be offered from a manufacturer who must have designed, manufactured, tested, installed and commissioned substation automation system which must be in satisfactory operation on 220kV system or higher for at least 2 (Two) years as on the date of bid opening.~~

1.2. The Substation Automation System (SAS) shall be installed to control and monitor all the sub-station equipment from remote control centre (RCC) as well as from local control centre.

The SAS shall contain the following main functional parts:

- Bay control Intelligence Electronic Devices (IED s) for control and monitoring.
- Station Human Machine Interface (HMI)
- Redundant managed switched Ethernet Local Area Network communication infrastructure with hot standby.
- Gateway for remote control via industrial grade hardware (to RCC) through IEC60870-5-101 protocol.
- Gateway for remote supervisory control (to RSCC), the gateway should be able to communicate with RSCC on IEC 60870-5-101 protocol. The specific protocol to be implemented is enclosed as Appendix-I. For Northern Region -I & II, Eastern Region I & II and North Eastern Region interoperability profile shall be as per AREVA inter operability profile and for other regions it shall be as per GE's interoperability profile. It shall be the bidder's responsibility to integrate his offered system with existing RSCC system for exchange of desired data. The requirement of IO point shall be worked out by the bidder as per criterion enclosed as Appendix-II for data exchange with RLDCs.
- Remote HMI.
- Peripheral equipment like printers, display units, key boards, Mouse etc.

1.3. It shall enable local station control via a PC by means of human machine interface (HMI) and control software package, which shall contain an extensive range of supervisory control and data acquisition (SCADA) functions.

1.4. It shall include communication gateway, intelligent electronic devices (IED) for bay control and inter IED communication infrastructure. An architecture drawing for SAS is enclosed.

1.5. The communication gateway shall facilitate the information flow with remote control centres. The bay level intelligent electronic devices (IED) for protection and control shall provide the direct connection to the

switchgear without the need of interposing components and perform control, protection, and monitoring functions.

2. System design

2.1 General system design

The Substation Automation System (SAS) shall be suitable for operation and monitoring of the complete substation including future extensions as given in Section-Project. (I)

The systems shall be of the state-of-the art suitable for operation under electrical environment present in Extra high voltage substations, follow the latest engineering practice, ensure long-term compatibility requirements and continuity of equipment supply and the safety of the operating staff.

The offered SAS shall support remote control and monitoring from Remote Control centres via gateways.

The system shall be designed such that personnel without any background knowledge in Microprocessor-based technology are able to operate the system. The operator interface shall be intuitive such that operating personnel shall be able to operate the system easily after having received some basic training.

The system shall incorporate the control, monitoring and protection functions specified, self-monitoring, signalling and testing facilities, measuring as well as memory functions, event recording and evaluation of disturbance records.

Maintenance, modification or extension of components may not cause a shutdown of the whole substation automation system. Self-monitoring of components, modules and communication shall be incorporated to increase the availability and the reliability of the equipment and minimize maintenance.

Bidder shall offer the Bay level unit (a bay comprises of one circuit breaker and associated disconnecter, earth switches and instrument transformer), bay mimic along with relay and protection panels and ~~PLCC~~ ~~panels~~ (described in other sections of technical specifications) housed in air-conditioned Switchyard Panel Room (IN BHEL Scope) suitably located in switchyard and Station HMI in Control Room building for overall optimisation in respect of cabling and control room building..

2.2 System architecture

The SAS shall be based on a decentralized architecture and on a concept of bay-oriented, distributed intelligence.

Functions shall be decentralized, object-oriented and located as close as possible to the process.

The main process information of the station shall be stored in distributed databases. The typical SAS architecture shall be structured in two levels, i.e. in a station and a bay level.

At bay level, the IEDs shall provide all bay level functions regarding control, monitoring and protection, inputs for status indication and outputs for commands. The IEDs should be directly connected to the switchgear without any need for additional interposition or transducers.

Each bay control IED shall be independent from each other and its functioning shall not be affected by any fault occurring in any of the other bay control units of the station.

The data exchange between the electronic devices on bay and station level shall take place via the communication infrastructure. This shall be realized using fibre-optic cables, thereby guaranteeing disturbance free communication. The fibre optic cables shall be run in G.I conduit pipes. Data exchange is to be realised using IEC 61850 protocol with a redundant managed switched Ethernet communication infrastructure

The communication shall be made in fault tolerant ring in redundant mode, excluding the links between individual bay IEDs to switch wherein the redundant connections are not envisaged, such that failure of one set of fiber shall not affect the normal operation of the SAS. However failure of fiber shall be alarmed in SAS. Each fiber optic cable shall have four (4) spare fibers

At station level, the entire station shall be controlled and supervised from the station HMI. It shall also be possible to control and monitor the bay from the bay level equipment at all times.

Clear control priorities shall prevent operation of a single switch at the same time from more than one of the various control levels, i.e. RCC, station HMI, bay level or apparatus level. The priority shall always be on the lowest enabled control level.

The station level contains the station-oriented functions, which cannot be realised at bay level, e.g. alarm list or event list related to the entire substation, gateway for the communication with remote control centres.

The GPS time synchronising signal (as specified in the section relay & protection) for the synchronization of the entire system shall be provided.

The SAS shall contain the functional parts as described in para 1.2 above.

2.3 FUNCTIONAL REQUIREMENTS

The high-voltage apparatus within the station shall be operated from different places:

- Remote control centres
- Station HMI.
- Local Bay controller IED (in the bays)

Operation shall be possible by only one operator at a time.

The operation shall depend on the conditions of other functions, such as interlocking, synchrocheck, etc. (see description in "Bay level control functions").

2.3.1 Select-before-execute

For security reasons the command is always to be given in two stages: selection of the object and command for operation under all mode of operation except emergency operation. Final execution shall take place only when selection and command are actuated.

2.3.2 Command supervision

Bay/station interlocking and blocking

Software Interlocking is to be provided to ensure that inadvertent incorrect operation of switchgear causing damage and accidents in case of false operation does not take place.

In addition to software interlocking hardwired interlocking are to be provided for:

- (a) Bus Earth switch Interlocking
- (b) Transfer Bus interlocking (if applicable)

It shall be a simple layout, easy to test and simple to handle when upgrading the station with future bays. For software interlocking the bidder shall describe the scenario while an IED of another bay is switched off or fails.

A software interlock override function shall be provided which can be enabled to bypass the interlocking function.

2.3.3 Run Time Command cancellation

Command execution timer (configurable) must be available for each control level connection. If the control action is not completed within a specified time, the command should get cancelled.

2.3.4 Self-supervision

Continuous self-supervision function with self-diagnostic feature shall be included.

2.3.5 User configuration

The monitoring, controlling and configuration of all input and output logical signals and binary inputs and relay outputs for all built-in functions and signals shall be possible both locally and remotely.

It shall also be possible to interconnect and derive input and output signals, logic functions, using built-in functions, complex voltage and currents, additional logics (AND-gates, OR gates and timers). (Multi-activation of these additional functions should be possible).

The Functional requirement shall be divided into following levels:

- a. Bay (a bay comprises of one circuit breaker and associated disconnecter, earth switches and instrument transformer) Level Functions
- b. System Level Functions

3.1. Bay level functions

In a decentralized architecture the functionality shall be as close to the process as possible. In this respect, the following functions can be allocated at bay level:

- Bay control functions including data collection functionality in bay control/protection unit.
- Bay protection functions

Separate IEDs shall be provided for bay control function and bay protection function.

3.1.1. Bay control functions

3.1.1.1. Overview

Functions

- Control mode selection
- Select-before-execute principle
- Command supervision:
 - Interlocking and blocking
 - Double command
- Synchrocheck, voltage selection
- Run Time Command cancellation
- Transformer tap changer control (Raise and lower of tap) (for power transformer bays)
- Operation counters for circuit breakers and pumps
- Hydraulic pump/ Air compressor runtime supervision
- Operating pressure supervision through digital contacts only
- Breaker position indication per phase
- Alarm annunciation
- Measurement display
- Local HMI (local guided, emergency mode)
- Interface to the station HMI.
- Data storage for at least 200 events
- Extension possibilities with additional I/O's inside the unit or via fibre-optic communication and process bus

3.1.1.2. Control mode selection

Bay level Operation:

As soon as the operator receives the operation access at bay level the operation is normally performed via bay control IED. During normal

operation bay control unit allows the safe operation of all switching devices via the bay control IED.

EMERGENCY Operation

It shall be possible to close or open the selected Circuit Breaker with ON or OFF push buttons even during the outage of bay IED.

REMOTE mode

Control authority in this mode is given to a higher level (Remote Control Centre) and the installation can be controlled only remotely. Control operation from lower levels shall not be possible in this operating mode.

3.1.1.3. Synchronism and energizing check

The synchronism and energizing check functions shall be bay-oriented and distributed to the bay control and/or protection devices. These features are:

- Settable voltage, phase angle, and frequency difference.
- Energizing for dead line - live bus, live line - dead bus or dead line – dead bus with no synchro-check function.
- Synchronising between live line and live bus with synchro-check function

Voltage selection

The voltages relevant for the Synchro check functions are dependent on the station topology, i.e. on the positions of the circuit breakers and/or the isolators. The correct voltage for synchronizing and energizing is derived from the auxiliary switches of the circuit breakers, the isolator, and earthing switch and shall be selected automatically by the bay control and protection IEDs.

3.1.1.4. Transformer tap changer control

Raise and lower operation of OLTC taps of transformer shall be facilitated through Bay controller IED.

3.1.2. Bay protection functions

3.1.2.1. General

The protection functions are independent of bay control function. The protection shall be provided by separate protection IEDs (numerical relays) and other protection devices as per section Relay & Protection.

IEDs, shall be connected to the communication infrastructure for data sharing and meet the real-time communication requirements for automatic functions. The data presentation and the configuration of the various IEDs shall be compatible with the overall system communication and data exchange requirements.

Event and disturbance recording function

Each IED should contain an event recorder capable of storing at least 200 time-tagged events. The disturbance recorder function shall be as per detailed in section C&R

3.1.2.2. Bay Monitoring Function:

Analogue inputs for voltage and current measurements shall be connected directly to the voltage transformers (VT) and the current transformers (CT) without intermediate transducers. The values of active power (W), reactive power (VAR), frequency (Hz), and the rms values for voltage (U) and current (I) shall be calculated in the Bay control/protection unit.

3.2. System level functions

3.2.1. Status supervision

The position of each switchgear, e.g. circuit breaker, isolator, earthing switch, transformer tap changer etc., shall be supervised continuously. Every detected change of position shall be immediately displayed in the single-line diagram on the station HMI screen, recorded in the event list, and a hard copy printout shall be produced. Alarms shall be initiated in the case of spontaneous position changes.

The switchgear positions shall be indicated by two auxiliary switches, normally closed (NC) and normally open (NO), which shall give ambivalent signals. An alarm shall be initiated if these position indications are inconsistent or if the time required for operating mechanism to change position exceeds a predefined limit.

The SAS shall also monitor the status of sub-station auxiliaries. The status and control of auxiliaries shall be done through separate one or more IED and all alarm and analogue values shall be monitored and recoded through this IED.

3.2.2. Measurements

The analogue values acquired/calculated in bay control/protection unit shall be displayed locally on the station HMI and in the control centre. The abnormal values must be discarded. The analogue values shall be updated every 2 seconds.

Threshold limit values shall be selectable for alarm indications.

3.2.3. Event and alarm handling

Events and alarms are generated either by the switchgear, by the control IEDs, or by the station level unit. They shall be recorded in an event list in the station HMI. Alarms shall be recorded in a separate alarm list and appear on the screen. All, or a freely selectable group of events and alarms shall also be printed out on an event printer. The alarms and events shall be time-tagged with a time resolution of 1 ms. The tentative list for various feeders and systems are enclosed as Annexure-I

3.2.4. Station HMI

3.2.4.1. Substation HMI Operation:

On the HMI the object has to be selected first. In case of a blocking or interlocking conditions are not met, the selection shall not be possible and an appropriate alarm annunciation shall occur. If a selection is valid the position indication will show the possible direction, and the appropriate control execution button shall be pressed in order to close or open the corresponding object.

Control operation from other places (e.g. REMOTE) shall not be possible in this operating mode.

3.2.4.2. Presentation and dialogues

General

The operator station HMI shall be a redundant with hot standby and shall provide basic functions for supervision and control of the substation. The operator shall give commands to the switchgear on the screen via mouse clicks.

The HMI shall give the operator access to alarms and events displayed on the screen. Aside from these lists on the screen, there shall be a printout of alarms or events in an event log.

An acoustic alarm shall indicate abnormalities, and all unacknowledged alarms shall be accessible from any screen selected by the operator.

The following standard pictures shall be available from the HMI:

- Single-line diagram showing the switchgear status and measured values
- Control dialogues with interlocking or blocking information details. This control dialogue shall tell the operator whether the device operation is permitted or blocked.
- Measurement dialogues
- Alarm list, station / bay-oriented
- Event list, station / bay-oriented
- System status

3.2.4.3. HMI design principles

Consistent design principles shall be adopted with the HMI concerning labels, colours, dialogues and fonts. Non-valid selections shall be dimmed out.

The object status shall be indicated using different status colours for:

- Selected object under command
- Selected on the screen
- Not updated, obsolete values, not in use or not sampled
- Alarm or faulty state
- Warning or blocked

- Update blocked or manually updated
- Control blocked
- Normal state

3.2.4.4. Process status displays and command procedures

The process status of the substation in terms of actual values of currents, voltages, frequency, active and reactive powers as well as the positions of circuit breakers, isolators and transformer tap-changers shall be displayed in the station single-line diagram.

In order to ensure a high degree of security against undesired operation, a "select-before-execute" command procedure shall be provided. After the "selection" of a switch, the operator shall be able to recognize the selected device on the screen, and all other switchgear shall be blocked. As communication between control centre and device to be controlled is established, the operator shall be prompted to confirm the control action and only then final execute command shall be accepted. After the "execution" of the command the operated switching symbol shall flash until the switch has reached its new position.

The operator shall be in a position to execute a command only, if the switch is not blocked and if no interlocking condition is going to be violated. The interlocking statements shall be checked by the interlocking scheme implemented at bay and station level.

After command execution the operator shall receive a confirmation that the new switching position has been reached or an indication that the switching procedure was unsuccessful with the indication of the reason for non-functioning.

3.2.4.5. System supervision & display

The SAS system shall be comprehensively self-monitored such that faults are immediately indicated to the operator, possibly before they develop into serious situations. Such faults are recorded as a faulty status in a system supervision display. This display shall cover the status of the entire substation including all switchgear, IEDs, communication infrastructure and remote communication links, and printers at the station level, etc.

3.2.4.6. Event list

The event list shall contain events that are important for the control and monitoring of the substation.

The event and associated time (with 1 ms resolution) of its occurrence has to be displayed for each event.

The operator shall be able to call up the chronological event list on the monitor at any time for the whole substation or sections of it.

A printout of each display shall be possible on the hard copy printer.

The events shall be registered in a chronological event list in which the type of event and its time of occurrence are specified. It shall be possible

to store all events in the computer for at least one month. The information shall be obtainable also from a printed event log.

The chronological event list shall contain:

- Position changes of circuit breakers, isolators and earthing devices
- Indication of protective relay operations
- Fault signals from the switchgear
- Indication when analogue measured values exceed upper and lower limits. Suitable provision shall be made in the system to define two level of alarm on either side of the value or which shall be user defined for each measurands.
- Loss of communication.

Filters for selection of a certain type or group of events shall be available. The filters shall be designed to enable viewing of events grouped per:

- Date and time
- Bay
- Device
- Function e.g. trips, protection operations etc.
- Alarm class

3.2.4.7. Alarm list

Faults and errors occurring in the substation shall be listed in an alarm list and shall be immediately transmitted to the control centre. The alarm list shall substitute a conventional alarm tableau, and shall constitute an evaluation of all station alarms. It shall contain unacknowledged alarms and persisting faults. The date and time of occurrence shall be indicated.

The alarm list shall consist of a summary display of the present alarm situation. Each alarm shall be reported on one line that contains:

- The date and time of the alarm
- The name of the alarming object
- A descriptive text
- The acknowledgement state.

Whenever an alarm condition occurs, the alarm condition must be shown on the alarm list and must be displayed in a flashing state along with an audible alarm. After acknowledgement of the alarm, it should appear in a steady (i.e. not flashing) state and the audible alarm shall stop. The alarm should disappear only if the alarm condition has physically cleared and the operator has reset the alarm with a reset command. The state of the alarms shall be shown in the alarm list (Unacknowledged and persistent, Unacknowledged and cleared, Acknowledged and persistent).

Filters for selection of a certain type or group of alarms shall be available as for events.

3.2.4.8. Object picture

When selecting an object such as a circuit breaker or isolator in the single-line diagram, the associated bay picture shall be presented first. In the selected object picture, all attributes like

- Type of blocking
- Authority
- Local / remote control
- RSCC / SAS control
- Errors
- etc.,

shall be displayed.

3.2.4.9. Control dialogues

The operator shall give commands to the system by means of mouse click located on the single-line diagram. Data entry is performed with the keyboard. Dedicated control dialogues for controlling at least the following devices shall be available:

- Breaker and disconnecter
- Transformer tap-changer

3.2.5. User-authority levels

It shall be possible to restrict activation of the process pictures of each object (bays, apparatus...) within a certain user authorisation group. Each user shall then be given access rights to each group of objects, e.g.:

- Display only
- Normal operation (e.g. open/close of switchgear)
- Restricted operation (e.g. by-passed interlocking)
- System administrator

For maintenance and engineering purposes of the station HMI, the following authorisation levels shall be available:

- No engineering allowed
- Engineering/configuration allowed
- Entire system management allowed

The access rights shall be defined by passwords assigned during the log-in procedure. Only the system administrator shall be able to add/remove users and change access rights.

3.2.6. Reports

The reports shall provide time-related follow-ups of measured and calculated values. The data displayed shall comprise:

- Trend reports:
 - Day (mean, peak)
 - Month (mean, peak)
 - Semi-annual (mean, peak)
 - Year (mean, peak)
- Historical reports of selected analogue Values:
 - Day (at 15 minutes interval)
 - Week
 - Month
 - Year

It shall be possible to select displayed values from the database in the process display on-line. Scrolling between e.g. days shall be possible. Unsure values shall be indicated. It shall be possible to select the time period for which the specific data are kept in the memory.

Following printouts shall be available from the printer and shall be printed on demand:

- i. Daily voltage and frequency curves depicting time on X-axis and the appropriate parameters on the Y-axis. The time duration of the curve is 24 hours.
- ii. Weekly trend curves for real and derived analogue values.
- iii. Printouts of the maximum and minimum values and frequency of occurrence and duration of maximum and minimum values for each analogue parameter for each circuit in 24 hr period.
- iv. Provision shall be made for logging information about breaker status like number of operation with date and time indications along with the current vale it interrupts (in both condition i.e. manual opening and fault tripping)
- v. Equipment operation details shift wise and during 24 hours.
- vi. Printout on adjustable time period as well as on demand for MW, MVAR, Current, Voltage on each feeder and transformer as well as Tap Positions, temperature and status of pumps and fans for transformers.
- vii. Printout on adjustable time period as well as on demand system frequency and average frequency.
- viii. Reports in specified formats which shall be handed over to successful bidder. The bidder has to develop these reports. The

reports are limited to the formats for which data is available in the SAS database.

3.2.7. Trend display (historical data)

It shall be possible to illustrate all types of process data as trends - input and output data, binary and analogue data. The trends shall be displayed in graphical form as column or curve diagrams with a maximum of 10 trends per screen. Adjustable time span and scaling ranges must be provided.

It shall be possible to change the type of value logging (direct, mean, sum, or difference) on-line in the window. It shall also be possible to change the update intervals on-line in the picture as well as the selection of threshold values for alarming purposes.

3.2.8. Automatic disturbance file transfer

All recorded data from the IEDs with integrated disturbance recorder as well as dedicated disturbance recording systems shall be automatically uploaded (event triggered or once per day) to a dedicated computer and be stored on the hard disc.

3.2.9. Disturbance analysis

The PC-based work station shall have necessary software to evaluate all the required information for proper fault analysis.

3.2.10. IED parameter setting

It shall be possible to access all protection and control IEDs for reading the parameters (settings) from the station HMI or from a dedicated monitoring computer. The setting of parameters or the activation of parameter sets shall only be allowed after entering a password.

3.2.11. Automatic sequences

The available automatic sequences in the system should be listed and described, (e.g. sequences related to the bus transfer). It must be possible to initiate pre-defined automatic sequences by the operator and also define new automatic sequences.

3.3. Gateway

3.3.1 Communication Interface

The Substation Automation System shall have the capability to support simultaneous communications with multiple independent remote master stations,

The Substation Automation System shall have communication ports as follows:

- (a) Two ports for Remote Control Centre
- (b) Two ports for Regional System Coordination Centre (RSCC)

The communication interface to the SAS shall allow scanning and control

of defined points within the substation automation system independently for each control centre. The substation automation system shall simultaneously respond to independent scans and commands from employer's control centres (RCC & RSCC). The substation automation system shall support the use of a different communication data exchange rate (bits per second), scanning cycle, and/or communication protocol to each remote control centre. Also, each control centre's data scan and control commands may be different for different data points within the substation automation system's database.

3.3.2 Remote Control Centre Communication Interface

Employer will supply communication channels between the Substation Automation System and the remote control centre. The communication channels provided by Employer will consist either of power line carrier, microwave, optical fibre, VSAT or leased line , the details of which shall be provided during detailed Engineering .

3.3.3 Interface equipment:

The ~~Contractor~~^{bidder} shall provide interface equipment for communicating between Substation Automation system and Remote control centre and between Substation Automation system and Regional System Coordination Centre (RSCC). However, the communication channels available for this purpose are specified in section (project.) (Section - I)

In case of PLCC communication any modem supplied shall not require manual equalization and shall include self-test features such as manual mark/space keying, analogue loop-back, and digital loop-back. The modems shall provide for convenient adjustment of output level and receive sensitivity. The modem should be stand alone complete in all respects including power supply to interface the SAS with communication channel. The configuration of tones and speed shall be programmable and maintained in non-volatile memory in the modem. All necessary hardware and software shall also be in the scope of bidder except the communication link along with communication equipment between substation control room and Remote Control Centre.

3.3.4 Communication Protocol

The communication protocol for gateway to control centre must be open protocol and shall support IEC 60870-5-101 and IEC 61850 for all levels of communication for sub-station automation such as Bay to station HMI, gateway to remote station etc..

4.0 System hardware:

4.1 Redundant Station HMI, Remote HMI and Disturbance Recorder Work station:

^{Bidder}
The ~~contractor~~ shall provide redundant station HMI in hot standby mode.
The servers used in these work stations shall be of industrial grade.

It shall be capable to perform all functions for entire substation including future requirements as indicated in the SLD. It shall use industrial grade components. Processor and RAM shall be selected in such a manner that during normal operation not more than 30% capacity of processing and memory are used. Supplier shall demonstrate these features.

The capacity of hard disk shall be selected such that the following requirement should occupy less than 50% of disk space:

1. Storage of all analogue data (at 15 Minutes interval) and digital data including alarm, event and trend data for thirty(30) days,
2. Storage of all necessary software,
3. 20GB space for OWNER'S use.

Supplier shall demonstrate that the capacity of hard disk is sufficient to meet the above requirement.

4.1.1 HMI (Human Machine Interface)

The VDU shall show overview diagrams (Single Line Diagrams) and complete details of the switchgear with a colour display. All event and alarm annunciation shall be selectable in the form of lists. Operation shall be by a user friendly function keyboard and a cursor positioning device. The user interface shall be based on WINDOWS concepts with graphics & facility for panning, scrolling, zooming, decluttering etc.

4.1.2 Visual Display Units/TFT's (Thin Film Technology)

The display units shall have high resolution and reflection protected picture screen. High stability of the picture geometry shall be ensured. The screen shall be at least 21" diagonally in size and capable of colour graphic displays.

The display shall accommodate resolution of 1280 X 1024 pixels.

4.1.3 Printer

It shall be robust & suitable for operation with a minimum of 132 characters per line. The printing operation shall be quiet with a noise level of less than 45 dB suitable for location in the control room. Printer shall accept and print all ASCII characters via master control computer unit interface.

The printer shall have in built testing facility. Failure of the printer shall be indicated in the Station HMI. The printer shall have an off line mode selector switch to enable safe maintenance. The maintenance should be simple with provisions for ease of change of print head, ribbon changing, paper insertion etc.

All reports and graphics prints shall be printed on laser printer. One dot

matrix printer shall be exclusively used for hourly log printing.

All printers shall be continuously online.

4.1.4 Mass Storage Unit

The mass storage unit shall be built-in to the Station HMI. All operational measured values, and indications shall be stored in a mass-storage unit in form of DVD RW. The unit should support at least Read (48X), Write(24X), and Re-Write (10X) operations, with Multi-Session capability. It should support ISO9660, Rockridge and Joliet Filesystems. It should support formatting and use under the operating system provided for Station HMI. The monthly back up of data shall be taken on disc. The facility of back up of data shall be inherent in the software.

4.1.5 Switched Ethernet Communication Infrastructure:

The bidder shall provide the redundant switched optical Ethernet communication infrastructure for SAS. One switch shall be provided to connect all IEDs in one diameter of each 765 and 400kV yard and for two bays of 220kV yard to communication infrastructure. Each switch shall have at least two spare ports for connecting bay level IEDs and one spare port for connecting station bus.

4.2 Bay level unit

The bay unit shall use industrial grade components. The bay level unit, based on microprocessor technology, shall use numerical techniques for the calculation and evaluation of externally input analogue signals. They shall incorporate select-before-operate control principles as safety measures for operation via the HMI. They shall perform all bay related functions, such as control commands, bay interlocking, data acquisition, data storage, event recording and shall provide inputs for status indication and outputs for commands. They shall be directly connected to the switchgear. The bay unit shall acquire and process all data for the bay (Equipment status, fault indications, measured values, alarms etc.) and transmit these to the other devices in sub-station automation system. In addition, this shall receive the operation commands from station HMI and control centre. The bay unit shall have the capability to store all the data for at least 24 hours.

One no. Bay level unit shall be provided for supervision and control of each 765, 400 and 220 kV bay (a bay comprises of one circuit breaker and associated disconnector, earth switches and instrument transformer). The Bay level unit shall be equipped with analogue and binary inputs/outputs for handling the control, status monitoring and analogue measurement functions. All bay level interlocks are to be incorporated in the Bay level unit so as to permit control from the Bay level unit/ local bay mimic panel, with all bay interlocks in place, during maintenance and commissioning or in case of contingencies when the Station HMI is out of service.

The bay control unit to be provided for the bays shall be preferably installed in the CB relay panel/feeder protection panel for respective bay. Further in case of one and half breaker schemes, the BCU for Tie CB shall be provided in Tie CB relay panel. The tie CB relay panel shall also house the Ethernet switch(es) to be provided for the diameter. The bay control unit for future bay (if required as per section project) shall be installed in a separate panel.

The Bay level unit shall meet the requirements for withstanding electromagnetic interference according to relevant parts of IEC 61850. Failure of any single component within the equipment shall neither cause unwanted operation nor lead to a complete system breakdown.

4.2.1 Input/Output (I/O) modules

The I/O modules shall form a part of the bay level unit and shall provide coupling to the substation equipment. The I/O modules shall acquire all switchgear information (i.e. data coming directly from the switchgear or from switchgear interlocking devices) and transmit commands for operation of the switchgear. The measured values of voltage and current shall be from the secondaries of instrument transformers. The digital inputs shall be acquired by exception with 1 ms resolution. Contact bouncing in digital inputs shall not be assumed as change of state

4.3 Switchyard Panel Room:

The switchyard panel room shall be constructed to house Bay level units, bay mimic, relay and protection panels, PLCC panels etc. one each for a diameter in 765/400kV sub-station and for two bays in 220kV Level. In case of incomplete diameter the switchyard panel room shall have necessary space for accommodating the future bay IEDs. The layout of equipment/panel shall be subject to Owner's approval. The switchyard panel room shall be provided with necessary illuminations, fire alarm system with at least two detectors with necessary power supply if required and it shall be wired to SAS. The detailed constructional requirement of switchyard panel room is detailed in section civil of technical specification and air conditioning requirement of switchyard panel room shall be as detailed in section Air conditioning system of technical specification. The air conditioner provided in switchyard panel room shall be monitored from substation automation system.

4.4 Extendibility in future

Offered substation automation system shall be suitable for extension in future for additional bays. During such requirement, all the drawings and configurations, alarm/event list etc. displayed shall be designed in such a manner that its extension shall be easily performed by the employer.

During such event, normal operation of the existing substation shall be unaffected and system shall not require a shutdown. The ~~contractor~~^{bidder} shall provide all necessary software tools along with source codes to perform addition of bays in future and complete integration with SAS by the user. These software tools shall be able to configure IED, add additional analogue variable, alarm list, event list, modify interlocking logics etc. for additional bays/equipment which shall be added in future.

5.0 Software structure

The software package shall be structured according to the SAS architecture and strictly divided in various levels. Necessary firewall shall be provided at suitable points in software to protect the system. An extension of the station shall be possible with lowest possible efforts. Maintenance, modification or an extension of components of any feeder may not force a shut-down of the parts of the system which are not affected by the system adaptation.

5.1.1 Station level software

5.1.1.1 Human-machine interface (HMI)

The base HMI software package for the operator station shall include the main SAS functions and it shall be independent of project specific hardware version and operating system. It shall further include tools for picture editing, engineering and system configuration. The system shall be easy to use, to maintain, and to adapt according to specific user requirements. Systems shall contain a library with standard functions and applications.

5.1.2 Bay level software

5.1.1.1 System software

The system software shall be structured in various levels. This software shall be placed in a non-volatile memory. The lowest level shall assure system performance and contain basic functions, which shall not be accessible by the application and maintenance engineer for modifications. The system shall support the generation of typical control macros and a process database for user specific data storage. In case of restoration of links after failure, the software along with hardware shall be capable of automatically synchronising with the remaining system without any manual interface. This shall be demonstrated by ~~contractor~~^{bidder} during integrated system test.

5.1.1.2 Application software

In order to ensure robust quality and reliable software functions, the main part of the application software shall consist of standard software modules built as functional block elements. The functional blocks shall be documented and thoroughly tested. They form part of a library. The application software within the control/protection devices shall be programmed in a functional block language.

5.1.1.3 Network Management System:

The ^{Bidder}contractor shall provide a network management system software for following management functions:

- a. Configuration Management
- b. Fault Management
- c. Performance Monitoring

This system shall be used for management of communication devices and other IEDs in the system. This NMS can be loaded in DR workstation and shall be easy to use, user friendly and menu based. The NMS shall monitor all the devices in the SAS and report if there is any fault in the monitored devices. The NMS shall

- (a) Maintain performance, resource usage, and error statistics for all managed links and devices and present this information via displays, periodic reports and on demand reports.
- (b) Maintain a graphical display of SAS connectivity and device status.
- (c) Issue alarms when error conditions occurs
- (d) Provide facility to add and delete addresses and links

5.1.1.4 The ^{Bidder}contractor shall provide each software in two copies in CD to load into the system in case of any problem related with Hardware/Communication etc.

6.0 TESTS

The substation automation system offered by the bidder shall be subjected to following tests to establish compliance with IEC 61850 for EHV sub-station equipment installed in sheltered area in the outdoor switchyard and specified ambient conditions:

6.1 Type Tests:

6.1.1 Control IEDs and Communication Equipment:

- a. **Power Input:**
 - i. Auxiliary Voltage
 - ii. Current Circuits
 - iii. Voltage Circuits
 - iv. Indications
- b. **Accuracy Tests:**
 - i. Operational Measurd Values
 - ii. Currents
 - iii. Voltages
 - iv. Time resolution
- c. **Insulation Tests:**
 - i. Dielectric Tests
 - ii. Impulse Voltage withstand Test
- d. **Influencing Quantities**

- i. Limits of operation
- ii. Permissible ripples
- iii. Interruption of input voltage
- e. Electromagnetic Compatibility Test:**
 - i. 1 MHZ. burst disturbance test
 - ii. Electrostatic Discharge Test
 - iii. Radiated Electromagnetic Field Disturbance Test
 - iv. Electrical Fast transient Disturbance Test
 - v. Conducted Disturbances Tests induced by Radio Frequency Field
 - vi. Magnetic Field Test
 - vii. Emission (Radio interference level) Test.
 - viii. Conducted Interference Test
- f. Function Tests:**
 - i. Indication
 - ii. Commands
 - iii. Measured value Acquisition
 - iv. Display Indications
- g. Environmental tests:**
 - i. Cold Temperature
 - ii. Dry Heat
 - iii. Wet heat
 - iv. Humidity (Damp heat Cycle)
 - v. Vibration
 - vi. Bump
 - vii. Shock

6.2 Factory Acceptance Tests:

The supplier shall submit a test specification for factory acceptance test (FAT) and commissioning tests of the station automation system for approval. For the individual bay level IED's applicable type test certificates shall be submitted.

The manufacturing and configuration phase of the SAS shall be concluded by the factory acceptance test (FAT). The purpose is to ensure that the Contractor has interpreted the specified requirements correctly and that the FAT includes checking to the degree required by the user. The general philosophy shall be to deliver a system to site only after it has been thoroughly tested and its specified performance has been verified, as far as site conditions can be simulated in a test lab. During FAT the entire Sub-station Automation System including complete control and protection system to be supplied under present scope shall be tested for complete functionality and configuration in factory itself. The extensive testing shall be carried out during FAT. The purpose of Factory Acceptance Testing is to ensure trouble free installation at site. No major configuration setting of system is envisaged at site.

If the complete system consists of parts from various suppliers or some parts are already installed on site, the FAT shall be limited to sub-system tests. In such a case, the complete system test shall be performed on site

together with the site acceptance test (SAT).

6.2.1 Hardware Integration Tests:

The hardware integration test shall be performed on the specified systems to be used for Factory tests when the hardware has been installed in the factory. The operation of each item shall be verified as an integral part of system. Applicable hardware diagnostics shall be used to verify that each hardware component is completely operational and assembled into a configuration capable of supporting software integration and factory testing of the system. The equipment expansion capability shall also be verified during the hardware integration tests. The vendor specifically demonstrates how to add a device in future in SAS during FAT. The device shall be from a different manufacturer than the SAS supplier.

6.2.2 Integrated System Tests:

Integrated system tests shall verify the stability of the hardware and the software. During the tests all functions shall run concurrently and all equipment shall operate a continuous 100 Hours period. The integrated system test shall ensure the SAS is free of improper interactions between software and hardware while the system is operating as a whole.

6.3 Site Acceptance Tests:

The site acceptance tests (SAT) shall completely verify all the features of SAS hardware and software. The bidder shall submit the detailed SAT procedure and SAT procedure shall be read in conjunction with the specification.

7.0 SYSTEM OPERATION

7.1 Substation Operation

7.1.1 NORMAL OPERATION

Operation of the system by the operator from the remote RCC or at the substation shall take place via industry standard HMI(Human Machine interface) subsystem consisting of graphic colour VDU , a standard keyboard and a cursor positioning device (mouse).

The coloured screen shall be divided into 3 fields :

- i) Message field with display of present time and date
- ii) Display field for single line diagrams
- iii) Navigation bar with alarm/condition indication

For display of alarm annunciation, lists of events etc a separate HMI View node. shall be provided.

All operations shall be performed with mouse and/or a minimum number of function keys and cursor keys. The function keys shall have different meanings depending on the operation. The operator shall see the relevant meanings as function tests displayed in the command field (i.e. operator prompting). For control actions, the switchgear (i.e. circuit breaker etc.) requested shall be selectable on the display by means of the cursor keys. The switching element selected shall then appear on the background that shall be flashing in a different color. The operator prompting shall distinguish between:-

- Prompting of indications e.g. fault indications in the switchgear, and
- prompting of operational sequences e.g. execution of switching operations

The summary information displayed in the message field shall give a rapid display of alarm/message of the system in which a fault has occurred and alarm annunciation lists in which the fault is described more fully.

Each operational sequence shall be divided into single operation steps which are initiated by means of the function keys/WINDOW command by mouse. Operator prompting shall be designed in such a manner that only the permissible keys are available in the command field related to the specific operation step. Only those switching elements shall be accessed for which control actions are possible. If the operation step is rejected by the system, the operator prompting shall be supported by additional comments in the message field. The operation status shall be reset to the corresponding preceding step in the operation sequence by pressing one of the function keys. All operations shall be verified. Incorrect operations shall be indicated by comments in the message field and must not be executed.

The offer shall include a comprehensive description of the system. The above operation shall also be possible via WINDOWS based system by mouse.

8.0 POWER SUPPLY

Power for the substation automation system shall be derived from substation 220V DC system.

Inverter of suitable capacity shall be provided for station HMI **disturbance recorder evaluation unit** and its peripheral devices e.g. printer etc. In the event of Power failure, necessary safeguard software shall be built for proper shutdown.

9.0 DOCUMENTATION

The following documents shall be submitted for employer's approval during detailed engineering:

- (a) System Architecture Drawing
- (b) Hardware Specification
- (c) Functional Design Document

- (d) Clear procedure describing how to add an IED/bay/diameter in future covering all major supplier

The following documentation to be provided for the system in the course of the project shall be consistent, CAD supported, and of similar look/feel. All CAD drawings to be provide in "dxf" format.

- List of Drawings
- Substation automation system architecture
- Block Diagram
- Guaranteed technical parameters, Functional Design Specification and Guaranteed availability and reliability
- Calculation for power supply dimensioning
- I/O Signal lists
- Schematic diagrams
- List of Apparatus
- List of Labels
- Logic Diagram (hardware & software)
- **Switchyard Panel Room** layout drawing
- Control Room Lay-out
- Test Specification for Factory Acceptance Test (FAT)
- Product Manuals
- Assembly Drawing
- Operator's Manual
- Complete documentation of implemented protocols between various elements
- Listing of software and loadable in CD ROM
- Other documents as may be required during detailed engineering

Two sets of hard copy and Four sets of CD ROM containing all the as built documents/drawings shall be provided.

10.0 TRAINING, SUPPORT SERVICES, MAINTENANCE AND SPARES

10.1 Training

^{Bidder} Contractor personnel who are experienced instructors and who speak understandable English shall conduct training. The ^{Bidder} contractor shall arrange on its own cost all hardware training platform required for successful training and understanding in India. The ^{Bidder} Contractor shall provide all necessary training material. Each trainee shall receive individual copies of all technical manuals and all other documents used for training. These materials shall be sent to Employer at least two months before the scheduled commencement of the particular training course. Class materials, including the documents sent before the training courses as well as class handouts, shall become the property of Employer. Employer reserves the right to copy such materials, but for in-house training and use only. Hands-on training shall utilize equipment identical to

that being supplied to Employer.

For all training courses, the travel (e.g., airfare) and per-diem expenses will be borne by the participants.

The ~~Contractor~~^{Bidder} shall quote training prices as indicated in ~~BPS~~^{BOQ of Section -I}.

The schedule, location, and detailed contents of each course will be finalized during Employer/~~and Contractor~~^{Bidder} discussions.

10.2

Computer System Hardware Course

A computer system hardware course shall be offered, but at the system level only. The training course shall be designed to give Employer hardware personnel sufficient knowledge of the overall design and operation of the system so that they can correct obvious problems, configure the hardware, perform preventive maintenance, run diagnostic programs, and communicate with contract maintenance personnel. The following subjects shall be covered:

- (a) System Hardware Overview: Configuration of the system hardware.
- (b) Equipment Maintenance: Basic theory of operation, maintenance techniques and diagnostic procedures for each element of the computer system, e.g., processors, auxiliary memories, LANs, routers and printers. Configuration of all the hardware equipments.
- (c) System Expansion: Techniques and procedures to expand and add equipment such as loggers, monitors, and communication channels.
- (d) System Maintenance: Theory of operation and maintenance of the redundant hardware configuration, failover hardware, configuration control panels, and failover switches. Maintenance of protective devices and power supplies.
- (e) Subsystem Maintenance: Theory of design and operation, maintenance techniques and practices, diagnostic procedures, and (where applicable) expansion techniques and procedures. Classes shall include hands-on training for the specific subsystems that are part of Employer's equipment or part of similarly designed and configured subsystems. All interfaces to the computing equipment shall be taught in detail.
- (f) Operational Training: Practical training on preventive and corrective maintenance of all equipment, including use of special tools and instruments. This training shall be provided on Employer equipment, or on similarly configured systems.

10.3

Computer System Software Course

The ~~Contractor~~^{Bidder} shall provide a computer system software course that covers the following subjects:

- (a) System Programming: Including all applicable programming languages and all stand-alone service and utility packages provided

with the system. An introduction to software architecture, Effect of tuning parameters (OS software, Network software, database software etc.) on the performance of the system.

- (b) Operating System: Including the user aspects of the operating system, such as program loading and integrating procedures; scheduling, management, service, and utility functions; and system expansion techniques and procedures
- (c) System Initialization and Failover: Including design, theory of operation, and practice
- (d) Diagnostics: Including the execution of diagnostic procedures and the interpretation of diagnostic outputs,
- (e) Software Documentation: Orientation in the organization and use of system software documentation.
- (f) Hands-on Training: One week, with allocated computer time for trainee performance of unstructured exercises and with the course instructor available for assistance as necessary.

10.4 **Application Software Course**

The ^{Bidder} Contractor shall provide a comprehensive application software courses covering all applications including the database and display building course. The training shall include:

- (a) Overview: Block diagrams of the application software and data flows. Programming standards and program interface conventions.
- (b) Application Functions: Functional capabilities, design, and major algorithms. Associated maintenance and expansion techniques.
- (c) Software Development: Techniques and conventions to be used for the preparation and integration of new software functions.
- (d) Software Generation: Generation of application software from source code and associated software configuration control procedures.
- (e) Software Documentation: Orientation in the organization and use of functional and detailed design documentation and of programmer and user manuals.
- (f) Hands-on Training: One week, with allocated computer time for trainee performance of unstructured exercises and with the course instructor available for assistance as necessary.

10.5 **Requirement of training:**

The ^{Bidder} contractor shall provide training for POWERGRID / ^{UPPTCL} personnel comprehensively covering following courses.

| S. No. | Name of Course |
|--------|--------------------------|
| 1 | Computer System Hardware |
| 2 | Computer System Software |
| 3 | Application Software |

11.0 **Maintenance**

11.1 Maintenance Responsibility during the Guaranteed Availability Period.

During Guaranteed Availability Period, the ~~Contractor~~^{Bidder} shall take continual actions to ensure the guaranteed availability and shall make available all the necessary resources such as specialist personnel, spare parts, tools, test devices etc. for replacement or repair of all defective parts and shall have prime responsibility for keeping the system operational. During guarantee period as specified in (tender document), ~~contractor~~^{Bidder} shall arrange bi-monthly visit of their representative to site to review the performance of system and in case any defect/shortcoming etc. is observed during the period, the same shall be set right by the ~~contractor~~ within 15 days.

Bidder

12.0 RELIABILITY AND AVAILABILITY

The SAS shall be designed so that the failure of any single component, processor, or device shall not render the system unavailable. The SAS shall be designed to satisfy the very high demands for reliability and availability concerning:

- Mechanical and electrical design
- Security against electrical interference (EMI)
- High quality components and boards
- Modular, well-tested hardware
- Thoroughly developed and tested modular software
- Easy-to-understand programming language for application programming
- Detailed graphical documentation and application software
- Built-in supervision and diagnostic functions
- Security
 - Experience of security requirements
 - Process know-how
 - Select before execute at operation
 - Process status representation as double indications
- Distributed solution
- Independent units connected to the local area network
- Back-up functions
- Panel design appropriate to the harsh electrical environment and ambient conditions
- Panel grounding immune against transient ground potential rise

Outage terms

1) Outage

The state in which substation automation system or a unit of SAS is unavailable for Normal Operation as defined in the clause 7.1 due to an event directly related to the SAS or unit of SAS. In the event, the owner has taken any equipment/ system other than Sub-station Automation System for schedule/forced maintenance, the consequent outage to SAS shall not be considered as outage for the purpose of availability.

2) Actual outage duration (AOD)

The time elapsed in hours between the start and the end of an outage. The time shall be counted to the nearest 1/4th of an hour. Time less than 1/4th of an hour shall be counted as having duration of 1/4th of an hour.

3) Period Hours (PH)

The number of hours in the reporting period. In a full year the period hour are 8760h (8784h for a leap year).

4) Actual Outage hours (AOH)

The sum of actual outage duration within the reporting period

$$AOH = \sum AOD$$

5) Availability:

Each SAS shall have a total availability of 99.98 % i.e. the ratio of total time duration minus the actual outage duration to total time duration.

12.1 Guarantees Required

The availability for the complete SAS shall be guaranteed by the ~~Contractor~~^{Bidder}. Bidder shall include in their offer the detailed calculation for the availability. The ~~contractor~~^{Bidder} shall demonstrate their availability guaranteed by conducting the availability test on the total sub-station automation system as a whole after commissioning of total Sub-station Automation system. The test shall verify the reliability and integrity of all sub-systems. Under these conditions the test shall establish an overall availability of 99.98%. After the lapse of 1000 Hours of cumulative test time, test records shall be examined to determine the conformance with availability criterion. In case of any outage during the availability test, the ~~contractor~~^{Bidder} shall rectify the problem and after rectification, the 1000 Hours period start after such rectification. If test object has not been met the test shall continue until the specified availability is achieved.

The ~~contractor~~^{Bidder} has to establish the availability in a maximum period of three months from the date of commencement of the availability test.

After the satisfactory conclusion of test both ~~contractor~~^{Bidder} and employer shall mutually agree to the test results and if these results satisfy the availability criterion, the test is considered to be completed successfully. After that the system shall be taken over by the employer and then the guarantee period shall start.

13.0 Spares

13.1 Consumables:

All consumables such as paper, cartridges shall be supplied by the ~~contractor~~^{Bidder} till the SAS is taken over by the owner. .

13.2 Availability Spares:

In addition to mandatory spares as listed in section project for SAS, the bidder is required to list the spares, which may be required for ensuring the guaranteed availability during the guaranteed availability period. The final list of spares shall form part of scope of supply and accordingly the price thereof shall be quoted by the bidder and shall be considered in the evaluation of the bids. During the guaranteed availability period, the spare parts supplied by the Contractor shall be made available to the Contractor for usage subject to replenishment at the earliest. Thus, at the end of availability period the inventory of spares with the Employer shall be fully replenished by the Contractor. However, any additional spares required to meet the availability of the system (which are not a part of the above spares supplied by the Contractor) would have to be supplied immediately by the Contractor free of cost to the Employer.

14.0 LIST OF EQUIPMENTS

Quantity of equipments shall be decided by bidder in order to achieve guaranteed reliability and availability as declared by bidder.

- i) Station HMI
- ii) Redundant Station HMI (in Hot-stand by mode)
- iii) Bay level units along with bay mimic as detailed in section Project.
- iv) Bay Level Unit for Auxiliary system (as per requirement)
- v) Disturbance Recorder Work Station(Maintenance HMI)
- vi) Colour Laser Printer – 1 No. (For Reports & Disturbance records)
- vii) Dot matrix printers - (one each for Alarms and log sheets)
- viii) All interface equipment for gateway to RCC and RSCC
- ix) Communication infrastructure between Bay level units, Station HMI, Printers, gateways, redundant LAN etc. as required
- x) Remote workstation including HMI and along with one printer
- xi) Modems as per requirement.
- xii) Any other equipment as necessary.

List of Analogue and Digital Inputs

Basic Monitoring requirements are:

- Switchgear status indication
- Measurements (U, I, P, Q, f)
- Event
- Alarm
- Winding temperature of transformers & reactors
- ambient temperature
- Status and display of 415V LT system, 220V & 48V DC system
- Status of display of Fire protection system and Air conditioning system.
- Acquisition of all counters in PLCC panels through potential free contacts from PLCC or independently by counting the receive/send commands.
- Acquisition of alarm and fault record from protection relays
- Disturbance records
- Monitoring the state of batteries by displaying DC voltage, charging current and load current etc.
- Tap-position of Transformer

List of Inputs

The list of input for typical bays is as below:-

Analogue inputs

- i) For line

| | |
|---------|-------------------------------------|
| Current | R phase Y phase B phase |
| Voltage | R-Y phase Y-B phase B-R phase |

- ii) For transformer/reactor

| | |
|---------|-------------------------------|
| Current | R phase Y phase B phase |
|---------|-------------------------------|

 WTI (for transformer and reactor)
 Tap position (for transformer only)

- iii) For TBC and bus coupler

| | |
|---------|-------------------------------|
| Current | R phase Y phase B phase |
|---------|-------------------------------|

- iv) Common
- a) Voltage for Bus-I, Bus-II and Transfer bus wherever applicable
- | | |
|---------|-----------|
| Voltage | R-Y phase |
| | Y-B phase |
| | B-R phase |
- b) Frequency for Bus-I and Bus-II
- c) Ambient temperature (switchyard)
- d) **Switchyard Panel Room Temperature.**
- e) **LT system**
- i) Voltage R-Y, Y-B, B-R of Main Switch Board section-I
 - ii) Voltage R-Y, Y-B, B-R of Main Switch Board section-II
 - iii) Voltage R-Y, Y-B, B-R of Diesel Generator
 - iv) Current from LT transformer-I
 - v) Current from LT transformer-II
 - vi) Current from Diesel Generator
 - vii) Voltage of 220V DCDB-I
 - viii) Voltage of 220V DCDB-II
 - ix) Current from 220V Battery set-I
 - x) Current from 220V Battery set-II
 - xi) Current from 220V Battery charger-I
 - xii) Current from 220V Battery charger-II
 - xiii) Voltage of 48V DCDB-I
 - xiv) Voltage of 48V DCDB-II
 - xv) Current from 48V Battery set-I
 - xvi) Current from 48V Battery set-II
 - xvii) Current from 48V Battery charger-I
 - xviii) Current from 48V Battery charger-II

Digital Inputs

The list of input for various bays/SYSTEM is as follows:

1. Line bays
 - i) Status of each pole of CB.
 - ii) Status of Isolator, Earth switch
 - iii) CB trouble
 - iv) CB operation/closing lockout
 - v) Pole discrepancy optd
 - vi) Trip coil faulty
 - vii) LBB optd
 - viii) Bus bar protn trip relay optd
 - ix) Main bkr auto recloser operated
 - x) Tie/transfer auto recloser operated
 - xi) A/r lockout
 - xii) Tie/transfer bkr a/r lockout
 - xiii) Direct trip-I/II sent
 - xiv) Direct trip-I/II received
 - xv) Main I/II blocking
 - xvi) Main I/II-Inter trip send
 - xvii) Main I/II-Inter trip received
 - xviii) O/V STAGE – I operated
 - xix) O/V STAGE – II operated

| | |
|----------|--------------------------------------|
| xx) | FAULT LOCATOR FAULTY |
| xxi) | MAIN-I/II CVT FUSE FAIL |
| xxii) | MAIN-I PROTN TRIP |
| xxiii) | MAIN-II PROTN TRIP |
| xxiv) | MAIN-I PSB ALARM |
| xxv) | MAIN-I SOTF TRIP |
| xxvi) | MAIN-I R-PH TRIP |
| xxvii) | MAIN-I Y-PH TRIP |
| xxviii) | MAIN-I B-PH TRIP |
| xxix) | MAIN-I START |
| xxx) | MAIN-I/II Carrier aided trip |
| xxx1) | MAIN-I/II fault in reverse direction |
| xxxii) | MAIN-I/II ZONE-2 TRIP |
| xxxiii) | MAIN-I/II ZONE-3 TRIP |
| xxxiv) | MAIN-I/II weak end infeed optd |
| xxxv) | MAIN-II PSB alarm |
| xxxvi) | MAIN-II SOTF TRIP |
| xxxvii) | MAIN-II R-PH TRIP |
| xxxviii) | MAIN-II Y-PH TRIP |
| xxxix) | MAIN-II B-PH TRIP |
| xl) | MAIN-II start |
| xli) | MAIN-II aided trip |
| xlii) | MAIN-I/II fault in reverse direction |
| xliii) | Back-up o/c optd |
| xliv) | Back-up e/f optd |
| xlv) | 220V DC-I/II source fail |
| xlvi) | SPEECH CHANNEL FAIL |
| xlvii) | PLCC Protection Channel-I FAIL |
| xlviii) | PLCC Protection Channel-II FAIL |

2. Transformer bays

| | |
|--------|---|
| i) | Status of each pole of CB, Isolator, Earth switch |
| ii) | CB trouble |
| iii) | CB operation/closing lockout |
| iv) | Pole discrepancy optd |
| v) | Trip coil faulty |
| vi) | LBB optd |
| vii) | Bus bar protn trip relay optd |
| viii) | REF OPTD |
| ix) | DIF OPTD |
| x) | OVERFLUX ALARM (MV) |
| xi) | OVERFLUX TRIP (MV) |
| xii) | OVERFLUX ALARM (HV) |
| xiii) | OVERFLUX TRIP (HV) |
| xiv) | HV BUS CVT ½ FUSE FAIL |
| xv) | MV BUS CVT ½ FUSE FAIL |
| xvi) | OTI ALARM/TRIP |
| xvii) | PRD OPTD |
| xviii) | OVERLOAD ALARM |
| xix) | BUCHOLZ TRIP |
| xx) | BUCHOLZ ALARM |
| xxi) | OLTC BUCHOLZ ALARM |
| xxii) | OLTC BUCHOLZ TRIP |

- xxiii) OIL LOW ALARM
- xxiv) back-up o/c (HV) optd
- xxv) back-up e/f (HV)optd
- xxvi) 220v DC-I/II source fail
- xxvii) TAP MISMATCH
- xxviii) GR-A PROTN OPTD
- xxix) GR-B PROTN OPTD
- xxx) back-up o/c (MV) optd
- xxxi) back-up e/f (MV)optd

3. Transformer bays

- i) Status of each pole of CB, Isolator, Earth switch
- ii) CB trouble
- iii) CB operation/closing lockout
- iv) Pole discrepancy optd
- v) Trip coil faulty
- vi) LBB optd
- vii) Bus bar protn trip relay optd
- viii) REF OPTD
- ix) DIF OPTD
- x) HV BUS CVT ½ FUSE FAIL
- xi) OTI ALARM/TRIP
- xii) PRD OPTD
- xiii) BUCHOLZ TRIP
- xiv) BUCHOLZ ALARM
- xv) OIL LOW ALARM
- xvi) Back-up impedance relay
- xvii) 220v DC-I/II source fail
- xviii) GR-A PROTN OPTD
- xix) GR-B PROTN OPTD

4. Line/Bus Reactor bays (as applicable):

- i) Status of each pole of CB, Isolator, Earth switch
- ii) CB trouble
- iii) CB operation/closing lockout
- iv) Pole discrepancy optd
- v) Trip coil faulty
- vi) LBB optd
- vii) Bus bar protn trip relay optd
- viii) REF OPTD
- ix) DIF OPTD
- x) Line/ BUS CVT ½ FUSE FAIL
- xi) OTI ALARM/TRIP
- xii) PRD OPTD
- xiii) BUCHOLZ TRIP
- xiv) BUCHOLZ ALARM
- xv) OIL LOW ALARM
- xvi) Back-up impedance relay
- xvii) 220V DC-I/II source fail
- xviii) GR-A PROTN OPTD
- xix) GR-B PROTN OPTD

5 Bus bar Protection

- i) Bus bar main-I trip
- ii) Bus bar main-II trip
- iii) Bus bar zone-I CT open
- iv) Bus bar zone-II CT open
- v) Bus transfer CT sup. Optd
- vi) Bus transfer bus bar protn optd
- vii) Bus protection relay fail

6. Auxiliary system

- i) Incomer-I On/Off
- ii) Incomer-II On/Off
- iii) 415V Bus-I/II U/V
- iv) 415v bus coupler breaker on/off
- v) DG set bkr on/off
- vi) Alarm/trip signals as listed in Section: DG set
- vii) LT transformer-I Bunchholz Alarm & trip
- viii) LT transformer-II Buchloz Alarm & trip
- ix) LT transformer-I WTI Alarm & trip
- x) LT transformer-II WTI Alarm & trip
- xi) LT transformer-I OTI Alarm & trip
- xii) LT transformer-II OTI Alarm & trip
- xiii) PLCC exchange fail
- xiv) Time sync. Signal absent
- xv) Alarm/trip signals as listed in Section: Battery and Battery charger
- xvi) 220v DC-I earth fault
- xvii) 220v DC-II earth fault
- xviii) Alarm/trip signals as listed in Section: Fire protection system

7. Switchyard Panel Room:

- i) **AC Compressor 1 ON/OFF**
- ii) **AC Compressor 2 ON/OFF**
- iii) **Fire Detection 1 ON/OFF**
- iv) **Fire Detection 2 On/OFF**
- v) **Switchyard Panel Room Temperature High Alarm**

The exact number and description of digital inputs shall be as per detailed engineering requirement Apart from the above mentioned digital inputs, minimum of 200 inputs shall be kept for POWERGRID use in future.

TYPICAL ARCHITECTURAL DRAWING OF SUBSTATION AUTOMATION SYSTEM

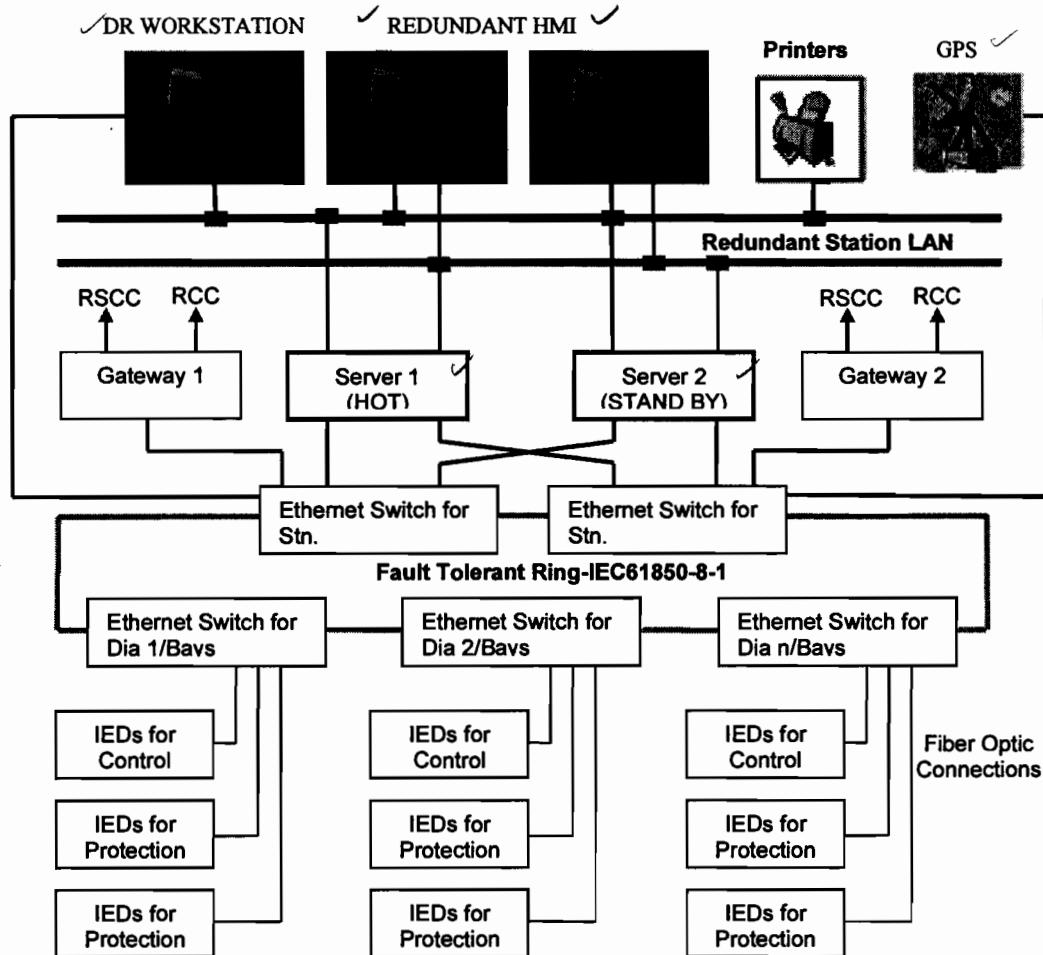

Note:

1. The redundant managed bus shall be realized by high speed optical bus using industrial grade components and shall be as per IEC 61850.
2. The IEDs and switches for each of the dia. of 765kV and 400kV shall have separate switchyard panel room. For 220kV yards, IEDs for two bays can be housed in one switchyard panel room along with its switch.
3. Inside the sub-station, all connections shall be realized as per IEC 61850 protocol.
4. For gateway, it shall communicate with Remote Supervisory Control Centre (RSCC) on IEC 60870-5-101 protocol.
5. The printer as required shall be connected to station bus directly and can be managed either from station HMI, HMI view node or disturbance recorder work station.
6. The above layout is typical. However if any contractor offers slightly modified architecture based on their standard practice without compromising the working, the same shall be subject to approval during detailed engineering.



INTEROPERABILITY PROFILE OF IEC 60870-5-101 PROTOCOL FOR NR, NER AND ER

This companion standard presents sets of parameters and alternatives from which subsets have to be selected to implement particular telecontrol systems. Certain parameter values, such as the number of octets in the COMMON ADDRESS of ASDUs represent mutually exclusive alternatives. This means that only one value of the defined parameters is admitted per system. Other parameters, such as the listed set of different process information in command and in monitor direction allow the specification of the complete set or subsets, as appropriate for given applications. This clause summarizes the parameters of the previous clauses to facilitate a suitable selection for a specific application. If a system is composed of equipment stemming from different manufacturers it is necessary that all partners agree on the selected parameters.

The selected parameters should be marked in the white boxes as follows:

| | |
|-------------------------------------|--|
| <input type="checkbox"/> | Function of ASDU is not used |
| <input checked="" type="checkbox"/> | Function or ASDU is used as standardized (default) |

Note : In addition, the full specification of a system may require individual selection of certain parameters for certain parts of the system, such as the individual selection of scaling factors for individually addressable measured values.



1.1 SYSTEM OR DEVICE

(System-specific parameter, indicate the definition of a system or a device by marking one of the following with an '■')

- System definition
- Controlling station definition (master)
- Controlled station definition (Slave)

1.2 NETWORK CONFIGURATION

(Network-specific parameter, all configurations that are used are to be marked with)

- Point-to-point
- Multiple point-to-point
- Multipoint-party line
- Multipoint-star

1.3 PHYSICAL LAYER (Network-specific parameter)

Transmission speed (control direction) :

*Unbalanced interchange
circuit V.24/V.28
Standard*

- 100 bit/s
- 200 bit/s
- 300 bit/s
- 600 bit/s
- 1 200 bit/s

(for unbalanced transmission only)

*Unbalanced interchange
circuit V.24/V.28
Recommended if >1 200 bit/s*

- 2 400 bit/s (ERLDC only)
- 4 800 bit/s
- 9 600 bit/s

*Balanced interchange
circuit X.24/X.27*

- 2 400 bit/s
- 4 800 bit/s
- 9 600 bit/s
- 19 200 bit/s
- 38 400 bit/s
- 56 000 bit/s
- 64 000 bit/s

Transmission speed (monitor direction) :

*Unbalanced interchange
circuit V.24/V.28
Standard*

*Unbalanced interchange
circuit V.24/V.28
Recommended if >1 200 bit/s*

*Balanced interchange
circuit X.24/X.27*



| | | | | | |
|-------------------------------------|---|-------------------------------------|-------------------------|--------------------------|--------------|
| <input type="checkbox"/> | 100 bit/s | <input checked="" type="checkbox"/> | 2 400 bit/s(ERLDC only) | <input type="checkbox"/> | 2 400 bit/s |
| <input checked="" type="checkbox"/> | 200 bit/s | <input type="checkbox"/> | 4 800 bit/s | <input type="checkbox"/> | 4 800 bit/s |
| <input checked="" type="checkbox"/> | 300 bit/s | <input type="checkbox"/> | 9 600 bit/s | <input type="checkbox"/> | 9 600 bit/s |
| <input checked="" type="checkbox"/> | 600 bit/s | | | <input type="checkbox"/> | 19 200 bit/s |
| <input checked="" type="checkbox"/> | 1 200 bit/s | | | <input type="checkbox"/> | 38 400 bit/s |
| | <i>(for unbalanced transmission only)</i> | | | <input type="checkbox"/> | 56 000 bit/s |
| | | | | <input type="checkbox"/> | 64 000 bit/s |

1.4 LINK LAYER (*Network-specific parameter*)

Frame format FT 1.2, single character 1 and the fixed time out interval are used exclusively in this companion standard.

Link transmission procedure

- Balanced transmission
- Unbalanced transmission

Address field of the link

- Not present (balanced transmission only)
- One octet
- Two octets
- Structured
- Unstructured

Frame length

255 Maximum length L (number of octets)

1.5 APPLICATION LAYER

Transmission mode for application data

Mode 1 (Least significant octet first), as defined in clause 4.10 of IEC 870-5-4, is used exclusively in this companion standard.

Common address of ASDU

(system-specific parameter)

- One octet
- Two octets

Information object address

(system-specific parameter)



-
- | | |
|--|--|
| <input type="checkbox"/> One octet | <input type="checkbox"/> Structured |
| <input checked="" type="checkbox"/> Two octets | <input checked="" type="checkbox"/> Unstructured |
| <input type="checkbox"/> Three octets | |

Cause of transmission
(system-specific parameter)

- | | |
|---|---|
| <input checked="" type="checkbox"/> One octet | <input type="checkbox"/> Two octets (with originator address) |
|---|---|

Selection of standard ASDUs
(station-specific parameter)

- | | |
|--|-----------|
| <input checked="" type="checkbox"/> <1> := Single-point information | M_SP_NA_1 |
| <input checked="" type="checkbox"/> <2> := Single-point information with time tag | M_SP_TA_1 |
| <input checked="" type="checkbox"/> <3> := Double-point information | M_DP_NA_1 |
| <input checked="" type="checkbox"/> <4> := Double-point information with time tag | M_DP_TA_1 |
| <input type="checkbox"/> <5> := Step position information | M_ST_NA_1 |
| <input type="checkbox"/> <6> := Step position information with time tag | M_ST_TA_1 |
| <input type="checkbox"/> <7> := Bitstring of 32 bit | M_BO_NA_1 |
| <input type="checkbox"/> <8> := Bitstring of 32 bit with time tag | M_BO_TA_1 |
| <input checked="" type="checkbox"/> <9> := Measured value, normalized value | M_ME_NA_1 |
| <input type="checkbox"/> <10> := Measured value, normalized value with time tag | M_ME_TA_1 |
| <input checked="" type="checkbox"/> <11> := Measured value, scaled value | M_ME_NB_1 |
| <input type="checkbox"/> <12> := Measured value, scaled value with time tag | M_ME_TB_1 |
| <input type="checkbox"/> <13> := Measured value, short floating point value | M_ME_NC_1 |
| <input type="checkbox"/> <14> := Measured value, short floating point value with time tag | M_ME_TC_1 |
| <input checked="" type="checkbox"/> <15> := Integrated totals | M_IT_NA_1 |
| <input type="checkbox"/> <16> := Integrated totals with time tag | M_IT_TA_1 |
| <input type="checkbox"/> <17> := Event of protection equipment with time tag | M_EP_TA_1 |
| <input type="checkbox"/> <18> := Packed start events of protection equipment with time tag | M_EP_TB_1 |
| <input type="checkbox"/> <19> := Packed output circuit information of protection equipment with time tag | M_EP_TC_1 |
| <input type="checkbox"/> <20> := Packed single-point information with status change detection | M_PS_NA_1 |
| <input type="checkbox"/> <21> := Measured value, normalized value without quality descriptor | M_ME_ND_1 |

**Process information in control direction**

(station-specific parameter)

| | | | |
|-------------------------------------|---------|---|-----------|
| <input checked="" type="checkbox"/> | <45> := | Single command | C_SC_NA_1 |
| <input checked="" type="checkbox"/> | <46> := | Double command | C_DC_NA_1 |
| <input type="checkbox"/> | <47> := | Regulating step command | C_RC_NA_1 |
| <input type="checkbox"/> | <48> := | Set point command, normalized value | C_SE_NA_1 |
| <input checked="" type="checkbox"/> | <49> := | Set point command, scaled value(required only for analog output command)* | C_SE_NB_1 |
| <input type="checkbox"/> | <50> := | Set point command, short floating point value | C_SE_NC_1 |
| <input type="checkbox"/> | <51> := | Bitstring of 32 bit | C_BO_NA_1 |

System information in monitor direction

(station-specific parameter)

| | | | |
|-------------------------------------|---------|-----------------------|-----------|
| <input checked="" type="checkbox"/> | <70> := | End of initialization | M_EI_NA_1 |
|-------------------------------------|---------|-----------------------|-----------|

System information in control direction

(station-specific parameter)

| | | | |
|-------------------------------------|----------|---|-----------|
| <input checked="" type="checkbox"/> | <100> := | Interrogation command | C_IC_NA_1 |
| <input checked="" type="checkbox"/> | <101> := | Counter interrogation command | C_CI_NA_1 |
| <input type="checkbox"/> | <102> := | Read command | C_RD_NA_1 |
| <input checked="" type="checkbox"/> | <103> := | Clock synchronization command (optional, if GPS is used for time synch. of the RTU)* | C_CS_NA_1 |
| <input type="checkbox"/> | <104> := | Test command | C_TS_NA_1 |
| <input checked="" type="checkbox"/> | <105> := | Reset process command | C_RP_NA_1 |
| <input checked="" type="checkbox"/> | <106> := | Delay acquisition command (optional, if GPS is used for time synch. of the RTU)* | C_CD_NA_1 |

Parameter in control direction

(station-specific parameter)

| | | | |
|--------------------------|----------|---|-----------|
| <input type="checkbox"/> | <110> := | Parameter of measured value, normalized value | P_ME_NA_1 |
| <input type="checkbox"/> | <111> := | Parameter of measured value, scaled value | P_ME_NB_1 |
| <input type="checkbox"/> | <112> := | Parameter of measured value, short floating point value | P_ME_NC_1 |



<113> := Parameter activation P_AC_NA_1

File transfer (may not be required)*
(station-specific parameter)

- <120> := File ready F_FR_NA_1
- <121> := Section ready F_SR_NA_1
- <122> := Call directory, select file, call file, call section F_SC_NA_1
- <123> := Last section, last segment F_LS_NA_1
- <124> := Ack file, ack section F_AF_NA_1
- <125> := Segment F_SG_NA_1
- <126> := Directory F_DR_TA_1

Special use
(private range)

- <137> := Regulating delay command C_RC_NB_1
(for Raise/Lower command of OLTC .May not be required)*

1.6 BASIC APPLICATION FUNCTIONS

Station initialization
(station-specific parameter)

- Remote initialization

General interrogation
(system or station-specific parameter)

- Global
- Group 1 ■ Group 7 ■ Group 13
- Group 2 ■ Group 8 ■ Group 14
- Group 3 ■ Group 9 ■ Group 15
- Group 4 ■ Group 10 ■ Group 16
- Group 5 ■ Group 11
- Group 6 ■ Group 12 Addresses per group have to be defined

Clock synchronization



(station-specific parameter)

- Clock synchronization (optional, if GPS is used for time synch. of the RTU)*

Command transmission (Required only when control command is envisaged)*
(object-specific parameter)

- Direct command transmission
- Direct set point command transmission
- No additional definition
- Short pulse duration (duration determined by a system parameter in the outstation)
- Long pulse duration (duration determined by a system parameter in the outstation)
- Persistent output
- Select and execute command
- Select and execute set point command
- C_SE ACTTERM used

Transmission of integrated totals
(station or object-specific parameter)

- Counter request
- Counter freeze without reset
- Counter freeze with reset
- Counter reset
- General request counter
- Request counter group 1
- Request counter group 2
- Request counter group 3
- Request counter group 4

Addresses per group have to be defined

Parameter loading
(object-specific parameter)

- Threshold value
- Smoothing factor
- Low limit for transmission of measured value
- High limit for transmission of measured value

Parameter activation
(object-specific parameter)

- Act/deact of persistent cyclic or periodic transmission of the addressed object



File transfer

(station-specific parameter)

- **File transfer in monitor direction** (for SOE data file from RTU to RLDC, may not be required)*
- **File transfer in control direction** (for downloading of RTU database from RLDC-May not be required)*



2. ADDITIONAL INFORMATION ON IEC 60870-5-101 FOR NRLDC, NERLDC AND ERLDC

A. Telemetred Data and ASDU mapping

The following table explains the type of the telemetred data and corresponding ASDUs used to transmit this data as per IEC 60870-5-101 protocol. These are same for all the above three RLDCs.

| Type of Data | Data Unit type as per IEC | Description as per IEC | Data polling method | Interrogation group | Transmitted after Class-X request | Info Obj. Address range |
|---|---------------------------|--|---|---------------------------------|--|-------------------------|
| Analog inputs (P,Q, V, f, OLTC tap position) | ASDU-11 | Measured value scaled value | As cyclic data on Class 2 polls | | Class 2 | 8448- |
| Digital inputs – Single status (Isolators, Protection signals) <small>A single status object uses the same IOA address when being sent as ASDU-1 or ASDU-2 or as a file transfer</small> | ASDU-1 | Single point information | By exception (spontaneous) and on periodic Group scan | Group-1 | Class 1 on exception, Class 1 after Group 1 scan | 376- |
| | ASDU- 2 | Single point information with time tag | By exception (spontaneous) | | Class 1 on exception | 376- |
| Digital inputs – Double status (Circuit breakers) <small>A double status object uses the same IOA address when being sent as ASDU-3 or ASDU-4 or as a file transfer</small> | ASDU-3 | Double point information | By exception (spontaneous) and on periodic Group scan | Group-1 | Class 1 on exception, Class 1 after Group 1 scan | 256- |
| | ASDU-4 | Double point information with time tag | By exception (spontaneous) | | Class 1 on exception | 256- |
| Pulse accumulators | ASDU-15 | Integrated totals | By periodic counter interrogation | Group-1 (counter interrogation) | Class 2 | 12544- |
| Analog Outputs (Setpoint) | ASDU-48 | Set point command Normalized value | | | | 37120 |
| Digital Control command (CB Trip/Close) | ASDU 46 | Double command | | | | 33024- |
| SOE (Digital inputs with Time) | File* transfer | See the file format enclosed | | | | |



B. DATA POLLING METHOD

1. The RTU shall respond to the Master stations request for the at least the following commands as per the protocol:
 - Status of Link
 - Reset of Link
 - Delay acquisition command *
 - Clock synchronization command *
 - General interrogation command
 - Interrogation of Scan group 1 command (all status data)
 - Interrogation of Scan group 2 command (all analog data)
 - Class 1/2 data polling
 - File transfer in Monitor direction (SOE file)*

If supervisory control commands are envisaged, then SBO procedure is to be used.
2. RTU shall send all Analog and status data in response to the General interrogation command.
3. All digital inputs are to be assigned to Scan group-1.
4. Analogs are defined as periodic data and are sent to RLDC on Class 2 request. The periodicity varies from 10 seconds to 15 seconds depending upon the quantity of data and available bandwidth.
5. Digital input state changes are to be reported spontaneously by RTU as Class 1 data. The Digital input data have higher priority than Analog values. An integrity scan is performed for all the digital inputs using Scan group-1 at every 10 minutes interval.
6. The SOE (Sequence of Events) information is stored in a file in the RTU. The format of SOE data is enclosed in a separate file (please see the details in *SOE_erldc_nerldc_nrldc.pdf* document). This file is transferred using the file transfer feature of IEC 60870-5-101 protocol.

* *These features may not be required*



INTEROPERABILITY PROFILE OF IEC 60870-5-101 PROTOCOL FOR SR

This companion standard presents sets of parameters and alternatives from which subsets have to be selected to implement particular telecontrol systems. Certain parameter values, such as the number of octets in the COMMON ADDRESS of ASDUs represent mutually exclusive alternatives. This means that only one value of the defined parameters is admitted per system. Other parameters, such as the listed set of different process information in command and in monitor direction allow the specification of the complete set or subsets, as appropriate for given applications. This clause summarizes the parameters of the previous clauses to facilitate a suitable selection for a specific application. If a system is composed of equipment stemming from different manufacturers it is necessary that all partners agree on the selected parameters.

The selected parameters should be marked in the white boxes as follows:

| | |
|-------------------------------------|--|
| <input type="checkbox"/> | Function of ASDU is not used |
| <input checked="" type="checkbox"/> | Function or ASDU is used as standardized (default) |

Note : In addition, the full specification of a system may require individual selection of certain parameters for certain parts of the system, such as the individual selection of scaling factors for individually addressable measured values.



1.1 SYSTEM or DEVICE

(System-specific parameter, indicate the definition of a system or a device by marking one of the following with an 'X')

- System definition
- Controlling station definition (master)
- Controlled station definition (Slave)

1.2 NETWORK CONFIGURATION

(Network-specific parameter, all configurations that are used are to be marked with)

- Point-to-point
- Multiple point-to-point
- Multipoint-party line
- Multipoint-star

1.3 PHYSICAL LAYER (Network-specific parameter)

Transmission speed (control direction) :

*Unbalanced interchange
circuit V.24/V.28
Standard*

- 100 bit/s
- 200 bit/s
- 300 bit/s
- 600 bit/s
- 1 200 bit/s

(for unbalanced transmission only)

*Unbalanced interchange
circuit V.24/V.28
Recommended if >1 200 bit/s*

- 2 400 bit/s
- 4 800 bit/s
- 9 600 bit/s

*Balanced interchange
circuit X.24/X.27*

- 2 400 bit/s
- 4 800 bit/s
- 9 600 bit/s
- 19 200 bit/s
- 38 400 bit/s
- 56 000 bit/s
- 64 000 bit/s

Transmission speed (monitor direction) :

*Unbalanced interchange
circuit V.24/V.28
Standard*

*Unbalanced interchange
circuit V.24/V.28
Recommended if >1 200 bit/s*

*Balanced interchange
circuit X.24/X.27*



-
- | | | | | | |
|-------------------------------------|---|--------------------------|-------------|--------------------------|--------------|
| <input type="checkbox"/> | 100 bit/s | <input type="checkbox"/> | 2 400 bit/s | <input type="checkbox"/> | 2 400 bit/s |
| <input checked="" type="checkbox"/> | 200 bit/s | <input type="checkbox"/> | 4 800 bit/s | <input type="checkbox"/> | 4 800 bit/s |
| <input checked="" type="checkbox"/> | 300 bit/s | <input type="checkbox"/> | 9 600 bit/s | <input type="checkbox"/> | 9 600 bit/s |
| <input checked="" type="checkbox"/> | 600 bit/s | | | <input type="checkbox"/> | 19 200 bit/s |
| <input checked="" type="checkbox"/> | 1 200 bit/s | | | <input type="checkbox"/> | 38 400 bit/s |
| | <i>(for unbalanced transmission only)</i> | | | <input type="checkbox"/> | 56 000 bit/s |
| | | | | <input type="checkbox"/> | 64 000 bit/s |

1.4 LINK LAYER (*Network-specific parameter*)

Frame format FT 1.2, single character 1 and the fixed time out interval are used exclusively in this companion standard.

Link transmission procedure

- Balanced transmission
- Unbalanced transmission

Address field of the link

- Not present (balanced transmission only)
- One octet
- Two octets
- Structured
- Unstructured

Frame length

255 Maximum length L (number of octets)

1.5 APPLICATION LAYER

Transmission mode for application data

Mode 1 (Least significant octet first), as defined in clause 4.10 of IEC 870-5-4, is used exclusively in this companion standard.

Common address of ASDU (system-specific parameter)

- One octet
- Two octets

Information object address (system-specific parameter)



- | | |
|--|--|
| <input type="checkbox"/> One octet | <input type="checkbox"/> Structured |
| <input checked="" type="checkbox"/> Two octets | <input checked="" type="checkbox"/> Unstructured |
| <input type="checkbox"/> Three octets | |

Cause of transmission

(system-specific parameter)

- | | |
|---|---|
| <input checked="" type="checkbox"/> One octet | <input type="checkbox"/> Two octets (with originator address) |
|---|---|

Selection of standard ASDUs

(station-specific parameter)

- | | |
|--|-----------|
| <input checked="" type="checkbox"/> <1> := Single-point information | M_SP_NA_1 |
| <input checked="" type="checkbox"/> <2> := Single-point information with time tag | M_SP_TA_1 |
| <input type="checkbox"/> <3> := Double-point information | M_DP_NA_1 |
| <input type="checkbox"/> <4> := Double-point information with time tag | M_DP_TA_1 |
| <input type="checkbox"/> <5> := Step position information | M_ST_NA_1 |
| <input type="checkbox"/> <6> := Step position information with time tag | M_ST_TA_1 |
| <input checked="" type="checkbox"/> <7> := Bitstring of 32 bit | M_BO_NA_1 |
| <input type="checkbox"/> <8> := Bitstring of 32 bit with time tag | M_BO_TA_1 |
| <input checked="" type="checkbox"/> <9> := Measured value, normalized value | M_ME_NA_1 |
| <input type="checkbox"/> <10> := Measured value, normalized value with time tag | M_ME_TA_1 |
| <input type="checkbox"/> <11> := Measured value, scaled value | M_ME_NB_1 |
| <input type="checkbox"/> <12> := Measured value, scaled value with time tag | M_ME_TB_1 |
| <input type="checkbox"/> <13> := Measured value, short floating point value | M_ME_NC_1 |
| <input type="checkbox"/> <14> := Measured value, short floating point value with time tag | M_ME_TC_1 |
| <input checked="" type="checkbox"/> <15> := Integrated totals | M_IT_NA_1 |
| <input type="checkbox"/> <16> := Integrated totals with time tag | M_IT_TA_1 |
| <input type="checkbox"/> <17> := Event of protection equipment with time tag | M_EP_TA_1 |
| <input type="checkbox"/> <18> := Packed start events of protection equipment with time tag | M_EP_TB_1 |
| <input type="checkbox"/> <19> := Packed output circuit information of protection equipment with time tag | M_EP_TC_1 |



-
- | | | | |
|--------------------------|---------|--|-----------|
| <input type="checkbox"/> | <20> := | Packed single-point information with status change detection | M_PS_NA_1 |
| <input type="checkbox"/> | <21> := | Measured value, normalized value without quality descriptor | M_ME_ND_1 |

Process information in control direction

(station-specific parameter)

- | | | | |
|-------------------------------------|---------|---|-----------|
| <input checked="" type="checkbox"/> | <45> := | Single command | C_SC_NA_1 |
| <input type="checkbox"/> | <46> := | Double command | C_DC_NA_1 |
| <input type="checkbox"/> | <47> := | Regulating step command | C_RC_NA_1 |
| <input checked="" type="checkbox"/> | <48> := | Set point command, normalized value (required only for analog output command)* | C_SE_NA_1 |
| <input type="checkbox"/> | <49> := | Set point command, scaled value | C_SE_NB_1 |
| <input type="checkbox"/> | <50> := | Set point command, short floating point value | C_SE_NC_1 |
| <input type="checkbox"/> | <51> := | Bitstring of 32 bit | C_BO_NA_1 |

System information in monitor direction

(station-specific parameter)

- | | | | |
|-------------------------------------|---------|-----------------------|-----------|
| <input checked="" type="checkbox"/> | <70> := | End of initialization | M_EI_NA_1 |
|-------------------------------------|---------|-----------------------|-----------|

System information in control direction

(station-specific parameter)

- | | | | |
|-------------------------------------|----------|---|-----------|
| <input checked="" type="checkbox"/> | <100> := | Interrogation command | C_IC_NA_1 |
| <input checked="" type="checkbox"/> | <101> := | Counter interrogation command | C_CI_NA_1 |
| <input type="checkbox"/> | <102> := | Read command | C_RD_NA_1 |
| <input checked="" type="checkbox"/> | <103> := | Clock synchronization command (optional, if GPS is used for time synch. of the RTU)* | C_CS_NA_1 |
| <input type="checkbox"/> | <104> := | Test command | C_TS_NA_1 |
| <input type="checkbox"/> | <105> := | Reset process command | C_RP_NA_1 |
| <input checked="" type="checkbox"/> | <106> := | Delay acquisition command (optional, if GPS is used for time synch. of the RTU)* | C_CD_NA_1 |

Parameter in control direction

(station-specific parameter)



-
- | | | |
|-----------------------------------|---|-----------|
| <input type="checkbox"/> <110> := | Parameter of measured value, normalized value | P_ME_NA_1 |
| <input type="checkbox"/> <111> := | Parameter of measured value, scaled value | P_ME_NB_1 |
| <input type="checkbox"/> <112> := | Parameter of measured value, short floating point value | P_ME_NC_1 |
| <input type="checkbox"/> <113> := | Parameter activation | P_AC_NA_1 |

File transfer (for downloading of database from RLDC, may not be required) *
(station-specific parameter)

- | | | |
|--|--|-----------|
| <input checked="" type="checkbox"/> <120> := | File ready | F_FR_NA_1 |
| <input checked="" type="checkbox"/> <121> := | Section ready | F_SR_NA_1 |
| <input checked="" type="checkbox"/> <122> := | Call directory, select file, call file, call section | F_SC_NA_1 |
| <input checked="" type="checkbox"/> <123> := | Last section, last segment | F_LS_NA_1 |
| <input checked="" type="checkbox"/> <124> := | Ack file, ack section | F_AF_NA_1 |
| <input checked="" type="checkbox"/> <125> := | Segment | F_SG_NA_1 |
| <input type="checkbox"/> <126> := | Directory | F_DR_TA_1 |

1.6 BASIC APPLICATION FUNCTIONS

Station initialization

(station-specific parameter)

- Remote initialization

General interrogation

(system or station-specific parameter)

- | | | |
|---|--|--|
| <input checked="" type="checkbox"/> Global | | |
| <input checked="" type="checkbox"/> Group 1 | <input checked="" type="checkbox"/> Group 7 | <input checked="" type="checkbox"/> Group 13 |
| <input checked="" type="checkbox"/> Group 2 | <input checked="" type="checkbox"/> Group 8 | <input checked="" type="checkbox"/> Group 14 |
| <input checked="" type="checkbox"/> Group 3 | <input checked="" type="checkbox"/> Group 9 | <input checked="" type="checkbox"/> Group 15 |
| <input checked="" type="checkbox"/> Group 4 | <input checked="" type="checkbox"/> Group 10 | <input checked="" type="checkbox"/> Group 16 |
| <input checked="" type="checkbox"/> Group 5 | <input checked="" type="checkbox"/> Group 11 | |
| <input checked="" type="checkbox"/> Group 6 | <input checked="" type="checkbox"/> Group 12 | Addresses per group have to be defined |

Clock synchronization



(station-specific parameter)

- Clock synchronization (optional, if GPS is used for time synch. of the RTU)*

Command transmission (Required only when control command is envisaged)*
(object-specific parameter)

- Direct command transmission
- Direct set point command transmission
- No additional definition
 - Short pulse duration (duration determined by a system parameter in the outstation)
 - Long pulse duration (duration determined by a system parameter in the outstation)
 - Persistent output
- Select and execute command
- Select and execute set point
- C_SE ACTTERM used

Transmission of integrated totals
(station or object-specific parameter)

- Counter request
- Counter freeze without reset
- Counter freeze with reset
- Counter reset
- General request counter
- Request counter group 1
- Request counter group 2
- Request counter group 3
- Request counter group 4

Addresses per group have to be defined

Parameter loading
(object-specific parameter)

- Threshold value
- Smoothing factor
- Low limit for transmission of measured value
- High limit for transmission of measured value

Parameter activation
(object-specific parameter)

- Act/deact of persistent cyclic or periodic transmission of the addressed object



File transfer

(station-specific parameter)

- File transfer in monitor direction
- File transfer in control direction (*For downloading of database from RLDC, May not be required*)*



2. ADDITIONAL INFORMATION ON IEC 60870-5-101 FOR SRLDC

A. Telemetred Data and ASDU mapping

The following table explains the type of the telemetred data and corresponding ASDUs used to transmit this data as per IEC 60870-5-101 protocol

| Type of power system Data | Data Unit type as per IEC | Description as per IEC | Data polling method | Interrogation group | Transmitted after Class-X request | Info Obj. Address range |
|---|---------------------------|--|---|---------------------------------|---|-------------------------|
| Analog inputs (P,Q, V, f) | ASDU-9 | Measured value normalized value | By periodic Group scan | Group-2 | Class 2 | 2001-3000 |
| Digital inputs –Single status (Circuit breakers, Isolators, Protection signals) | ASDU-1 | Single point information | By exception (spontaneous) and on periodic Group scan | Group-1 | Class 1 after exception, Class 2 after Group 1 scan | 1-1000 |
| | ASDU- 2 (for SOE) | Single point information with time tag | By exception (spontaneous) | | Class 1 after exception | 1001-2000 |
| Pulse accumulators | ASDU-15 | Integrated totals | By periodic counter interrogation | Group-1 (counter interrogation) | Class 2 | 4001-5000 |
| Analog Outputs (Setpoint) | ASDU-48 | Set point command Normalized value | | | | 5001-6000 |
| Digital Control command (CB Trip/Close) | ASDU 45 | Single command | | | | 3001-4000 |

B. DATA POLLING METHOD

- The RTU shall respond to the Master stations request for the at least the following commands as per the protocol:
 - Status of Link
 - Reset of Link
 - Delay acquisition command *
 - Clock synchronization command *
 - General interrogation command



- Interrogation of Scan group 1 command (all status data)
- Interrogation of Scan group 2 command (all analog data)
- Class 1/2 data polling

If supervisory control commands are envisaged, then SBO procedure is to be used.

2. Normal data polling is by Scan groups
3. All digital inputs are assigned to Scan group-1 and all Analog values are assigned to Scan group-2
4. Analog values are acquired periodically by using the Scan group-2 polling. This periodicity is ranging from 10-15 seconds based on the quantity of analogs and the communication channel bandwidth.
5. Digital input state changes are reported spontaneously by RTU as class 1 data and a integrity scan is performed for all the digital inputs using Scan group-1 at every 10 minutes interval.
6. Double bit digital status data are to be sent as two single-point information from the RTU.

** These features may not be required*



INTEROPERABILITY PROFILE OF IEC 60870-5-101 PROTOCOL FOR WR

This companion standard presents sets of parameters and alternatives from which subsets have to be selected to implement particular telecontrol systems. Certain parameter values, such as the number of octets in the COMMON ADDRESS of ASDUs represent mutually exclusive alternatives. This means that only one value of the defined parameters is admitted per system. Other parameters, such as the listed set of different process information in command and in monitor direction allow the specification of the complete set or subsets, as appropriate for given applications. This clause summarizes the parameters of the previous clauses to facilitate a suitable selection for a specific application. If a system is composed of equipment stemming from different manufacturers it is necessary that all partners agree on the selected parameters.

The selected parameters should be marked in the white boxes as follows:

| | |
|-------------------------------------|--|
| <input type="checkbox"/> | Function of ASDU is not used |
| <input checked="" type="checkbox"/> | Function or ASDU is used as standardized (default) |

Note : In addition, the full specification of a system may require individual selection of certain parameters for certain parts of the system, such as the individual selection of scaling factors for individually addressable measured values.



1.1 SYSTEM or DEVICE

(System-specific parameter, indicate the definition of a system or a device by marking one of the following with an 'X')

- System definition
- Controlling station definition (master)
- Controlled station definition (Slave)

1.2 NETWORK CONFIGURATION

(Network-specific parameter, all configurations that are used are to be marked with)

- Point-to-point
- Multipoint-party line
- Multiple point-to-point
- Multipoint-star

1.3 PHYSICAL LAYER (Network-specific parameter)

Transmission speed (control direction) :

*Unbalanced interchange
circuit V.24/V.28
Standard*

- 100 bit/s
- 200 bit/s
- 300 bit/s
- 600 bit/s
- 1 200 bit/s

(for unbalanced transmission only)

*Unbalanced interchange
circuit V.24/V.28
Recommended if >1 200 bit/s*

- 2 400 bit/s
- 4 800 bit/s
- 9 600 bit/s

*Balanced interchange
circuit X.24/X.27*

- 2 400 bit/s
- 4 800 bit/s
- 9 600 bit/s
- 19 200 bit/s
- 38 400 bit/s
- 56 000 bit/s
- 64 000 bit/s

Transmission speed (monitor direction) :

*Unbalanced interchange
circuit V.24/V.28
Standard*

*Unbalanced interchange
circuit V.24/V.28
Recommended if >1 200 bit/s*

*Balanced interchange
circuit X.24/X.27*



-
- | | | | | | |
|-------------------------------------|---|--------------------------|-------------|--------------------------|--------------|
| <input type="checkbox"/> | 100 bit/s | <input type="checkbox"/> | 2 400 bit/s | <input type="checkbox"/> | 2 400 bit/s |
| <input type="checkbox"/> | 200 bit/s | <input type="checkbox"/> | 4 800 bit/s | <input type="checkbox"/> | 4 800 bit/s |
| <input checked="" type="checkbox"/> | 300 bit/s | <input type="checkbox"/> | 9 600 bit/s | <input type="checkbox"/> | 9 600 bit/s |
| <input checked="" type="checkbox"/> | 600 bit/s | | | <input type="checkbox"/> | 19 200 bit/s |
| <input checked="" type="checkbox"/> | 1 200 bit/s | | | <input type="checkbox"/> | 38 400 bit/s |
| | <i>(for unbalanced transmission only)</i> | | | <input type="checkbox"/> | 56 000 bit/s |
| | | | | <input type="checkbox"/> | 64 000 bit/s |

1.4 LINK LAYER (*Network-specific parameter*)

Frame format FT 1.2, single character 1 and the fixed time out interval are used exclusively in this companion standard.

Link transmission procedure

- Balanced transmission
- Unbalanced transmission

Address field of the link

- Not present (balanced transmission only)
- One octet
- Two octets
- Structured
- Unstructured

Frame length

255 Maximum length L (number of octets)

1.5 APPLICATION LAYER

Transmission mode for application data

Mode 1 (Least significant octet first), as defined in clause 4.10 of IEC 870-5-4, is used exclusively in this companion standard.

Common address of ASDU (system-specific parameter)

- One octet
- Two octets

Information object address (system-specific parameter)



- | | |
|--|--|
| <input type="checkbox"/> One octet | <input type="checkbox"/> Structured |
| <input checked="" type="checkbox"/> Two octets | <input checked="" type="checkbox"/> Unstructured |
| <input type="checkbox"/> Three octets | |

Cause of transmission

(system-specific parameter)

- | | |
|---|---|
| <input checked="" type="checkbox"/> One octet | <input type="checkbox"/> Two octets (with originator address) |
|---|---|

Selection of standard ASDUs

(station-specific parameter)

- | | |
|--|-----------|
| <input checked="" type="checkbox"/> <1> := Single-point information | M_SP_NA_1 |
| <input checked="" type="checkbox"/> <2> := Single-point information with time tag | M_SP_TA_1 |
| <input checked="" type="checkbox"/> <3> := Double-point information | M_DP_NA_1 |
| <input checked="" type="checkbox"/> <4> := Double-point information with time tag | M_DP_TA_1 |
| <input type="checkbox"/> <5> := Step position information | M_ST_NA_1 |
| <input type="checkbox"/> <6> := Step position information with time tag | M_ST_TA_1 |
| <input checked="" type="checkbox"/> <7> := Bitstring of 32 bit | M_BO_NA_1 |
| <input type="checkbox"/> <8> := Bitstring of 32 bit with time tag | M_BO_TA_1 |
| <input checked="" type="checkbox"/> <9> := Measured value, normalized value | M_ME_NA_1 |
| <input type="checkbox"/> <10> := Measured value, normalized value with time tag | M_ME_TA_1 |
| <input type="checkbox"/> <11> := Measured value, scaled value | M_ME_NB_1 |
| <input type="checkbox"/> <12> := Measured value, scaled value with time tag | M_ME_TB_1 |
| <input type="checkbox"/> <13> := Measured value, short floating point value | M_ME_NC_1 |
| <input type="checkbox"/> <14> := Measured value, short floating point value with time tag | M_ME_TC_1 |
| <input checked="" type="checkbox"/> <15> := Integrated totals | M_IT_NA_1 |
| <input type="checkbox"/> <16> := Integrated totals with time tag | M_IT_TA_1 |
| <input type="checkbox"/> <17> := Event of protection equipment with time tag | M_EP_TA_1 |
| <input type="checkbox"/> <18> := Packed start events of protection equipment with time tag | M_EP_TB_1 |
| <input type="checkbox"/> <19> := Packed output circuit information of protection equipment with time tag | M_EP_TC_1 |



-
- | | | | |
|--------------------------|---------|--|-----------|
| <input type="checkbox"/> | <20> := | Packed single-point information with status change detection | M_PS_NA_1 |
| <input type="checkbox"/> | <21> := | Measured value, normalized value without quality descriptor | M_ME_ND_1 |

Process information in control direction
(station-specific parameter)

- | | | | |
|-------------------------------------|---------|---|-----------|
| <input checked="" type="checkbox"/> | <45> := | Single command | C_SC_NA_1 |
| <input checked="" type="checkbox"/> | <46> := | Double command | C_DC_NA_1 |
| <input type="checkbox"/> | <47> := | Regulating step command | C_RC_NA_1 |
| <input checked="" type="checkbox"/> | <48> := | Set point command, normalized value (required only for analog output command)* | C_SE_NA_1 |
| <input type="checkbox"/> | <49> := | Set point command, scaled value | C_SE_NB_1 |
| <input type="checkbox"/> | <50> := | Set point command, short floating point value | C_SE_NC_1 |
| <input type="checkbox"/> | <51> := | Bitstring of 32 bit | C_BO_NA_1 |

System information in monitor direction
(station-specific parameter)

- | | | | |
|-------------------------------------|---------|-----------------------|-----------|
| <input checked="" type="checkbox"/> | <70> := | End of initialization | M_EI_NA_1 |
|-------------------------------------|---------|-----------------------|-----------|

System information in control direction
(station-specific parameter)

- | | | | |
|-------------------------------------|----------|---|-----------|
| <input checked="" type="checkbox"/> | <100> := | Interrogation command | C_IC_NA_1 |
| <input checked="" type="checkbox"/> | <101> := | Counter interrogation command | C_CI_NA_1 |
| <input type="checkbox"/> | <102> := | Read command | C_RD_NA_1 |
| <input checked="" type="checkbox"/> | <103> := | Clock synchronization command (optional, if GPS is used for time synch. of the RTU)* | C_CS_NA_1 |
| <input type="checkbox"/> | <104> := | Test command | C_TS_NA_1 |
| <input type="checkbox"/> | <105> := | Reset process command | C_RP_NA_1 |
| <input checked="" type="checkbox"/> | <106> := | Delay acquisition command (optional, if GPS is used for time synch. of the RTU)* | C_CD_NA_1 |

Parameter in control direction
(station-specific parameter)



| | | |
|-----------------------------------|---|-----------|
| <input type="checkbox"/> <110> := | Parameter of measured value, normalized value | P_ME_NA_1 |
| <input type="checkbox"/> <111> := | Parameter of measured value, scaled value | P_ME_NB_1 |
| <input type="checkbox"/> <112> := | Parameter of measured value, short floating point value | P_ME_NC_1 |
| <input type="checkbox"/> <113> := | Parameter activation | P_AC_NA_1 |

File transfer (for downloading of database from RLDC, may not be required)*
(station-specific parameter)

| | | |
|--|--|-----------|
| <input checked="" type="checkbox"/> <120> := | File ready | F_FR_NA_1 |
| <input checked="" type="checkbox"/> <121> := | Section ready | F_SR_NA_1 |
| <input checked="" type="checkbox"/> <122> := | Call directory, select file, call file, call section | F_SC_NA_1 |
| <input checked="" type="checkbox"/> <123> := | Last section, last segment | F_LS_NA_1 |
| <input checked="" type="checkbox"/> <124> := | Ack file, ack section | F_AF_NA_1 |
| <input checked="" type="checkbox"/> <125> := | Segment | F_SG_NA_1 |
| <input type="checkbox"/> <126> := | Directory | F_DR_TA_1 |

1.6 BASIC APPLICATION FUNCTIONS

Station initialization

(station-specific parameter)

- Remote initialization

General interrogation

(system or station-specific parameter)

- Global
 - Group 1
 - Group 2
 - Group 3
 - Group 4
 - Group 5
 - Group 6
 - Group 7
 - Group 8
 - Group 9
 - Group 10
 - Group 11
 - Group 12
 - Group 13
 - Group 14
 - Group 15
 - Group 16
- Addresses per group have to be defined

Clock synchronization



(station-specific parameter)

- Clock synchronization (optional, if GPS is used for time synch. of the RTU)*

Command transmission (Required only when control command is envisaged)*
(object-specific parameter)

- | | |
|--|--|
| <input type="checkbox"/> Direct command transmission | <input checked="" type="checkbox"/> Select and execute command |
| <input type="checkbox"/> Direct set point command transmission | <input checked="" type="checkbox"/> Select and execute set point |
| | <input type="checkbox"/> C_SE ACTTERM used |
| | |
| <input checked="" type="checkbox"/> No additional definition | |
| Short pulse duration (duration determined by a system parameter in the outstation) | |
| Long pulse duration (duration determined by a system parameter in the outstation) | |
| Persistent output | |

Transmission of integrated totals
(station or object-specific parameter)

- | | |
|--|---|
| <input checked="" type="checkbox"/> Counter request | <input type="checkbox"/> General request counter |
| <input checked="" type="checkbox"/> Counter freeze without reset | <input type="checkbox"/> Request counter group 1 |
| <input checked="" type="checkbox"/> Counter freeze with reset | <input checked="" type="checkbox"/> Request counter group 2 |
| <input type="checkbox"/> Counter reset | <input type="checkbox"/> Request counter group 3 |
| | <input type="checkbox"/> Request counter group 4 |

Addresses per group have to be defined

Parameter loading
(object-specific parameter)

- Threshold value
- Smoothing factor
- Low limit for transmission of measured value
- High limit for transmission of measured value

Parameter activation
(object-specific parameter)

- Act/deact of persistent cyclic or periodic transmission of the addressed object



File transfer

(station-specific parameter)

- File transfer in monitor direction
- File transfer in control direction (*For downloading of database from RLDC, May not be required*)*

e



ADDITIONAL INFORMATION ON IEC 60870-5-101 FOR WRLDC

A. Telemetred Data and ASDU mapping

The following table explains the type of the telemetred data and corresponding ASDUs used to transmit this data as per IEC 60870-5-101 protocol

| Type of power system Data | Data Unit type as per IEC | Description as per IEC | Data polling method | Scan group | Transmitted after Class-X request | Info Obj. Address range |
|--|---------------------------|--|---|---------------------------------|---|-----------------------------|
| Analog inputs (P,Q, V, f) | ASDU-9 | Measured value normalized value | By periodic Group scan | Group-3 | Class 2 | 3001-4000 |
| Digital inputs – Single status (Isolators, Protection signals) | ASDU-1 | Single point information | By exception (spontaneous) and on periodic Group scan | Group-1 | Class 1 after exception, Class 1 after Group 1 scan | 1-1000 |
| | ASDU- 2 (for SOE) | Single point information with time tag | By exception (spontaneous) | | Class 1 after exception | 1001-2000 |
| Digital inputs - Double status (Circuit breaker) | ASDU 3 | Double point information | By exception (spontaneous) and on periodic Group scan | Group 2 | Class 1 after exception, Class 1 after Group 1 scan | 2001-3000 |
| | ASDU-4 | Double point information with time tag | By exception (spontaneous) | | Class 1 after exception | Same address range as above |
| Pulse accumulators | ASDU-15 | Integrated totals | By periodic counter interrogation | Group-1 (counter interrogation) | Class 2 | 5001-6000 |
| Analog Outputs (Setpoint) | ASDU-48 | Set point command Normalized value | | | | 6001-7000 |
| Digital Control command (CB Trip/Close) | ASDU 45 | Single command | | | | 4501-5000 |
| Digital Control command (CB Trip/Close) | ASDU 46 | Double command | | | | 4001-4500 |



B. DATA POLLING METHOD

1. The RTU shall respond to the Master stations request for the at least the following commands as per the protocol:
 - Status of Link
 - Reset of Link
 - Delay acquisition command *
 - Clock synchronization command *
 - General interrogation command
 - Interrogation of Scan group 1 command (all single status digital data)
 - Interrogation of Scan group 2 command (all double status digital data analog data)
 - Interrogation of Scan group 3 command (all analog data)
 - Class 1/2 data pollingIf supervisory control commands are envisaged, then SBO procedure is to be used.
2. Normal data polling is by Scan groups
3. All single digital inputs are assigned to Scan group-1, all double digital inputs are assigned to Scan group-2 and all Analog values are assigned to Scan group-3
4. Analog values are acquired periodically by using the Scan group-3 polling. This periodicity is ranging from 10-15 seconds based on the quantity of analogs and the communication channel bandwidth.
5. Digital input state changes are reported spontaneously by RTU as class 1 data and a integrity scan is performed for all the digital inputs using Scan group-1 and Scan group-2 at every 10 minutes interval.

** These features may not be required*

3 FUNCTIONAL SPECIFICATIONS

3.1 SOFTWARE EVOLUTIONS

3.1.1 RTU evolutions

3.1.1.1 Sequence of events (SOE)

The SOE data is time-oriented listings of status change events collected from RTUs. It is collected by the master station for subsequent review by relevant user personnel.

3.1.1.1.1 File structure

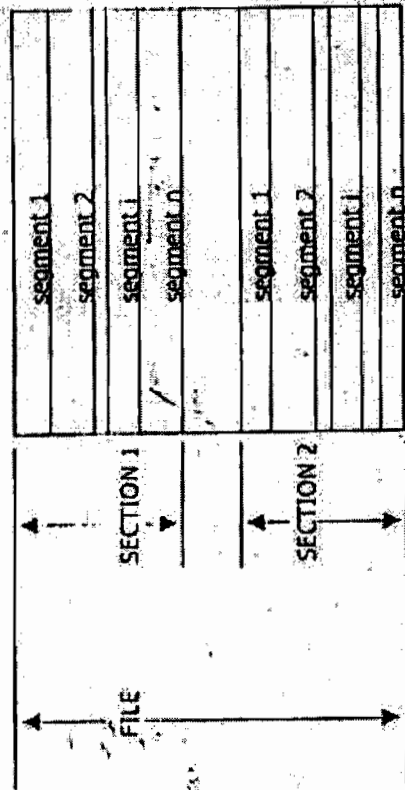

Figure 1. General construction of a file (in IEC 870-5-5)

Special S900 case:

RTU S900 use one section to transfer file such database (to RTU) and SOE file (to control centre).

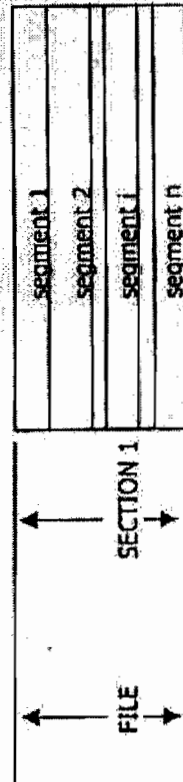
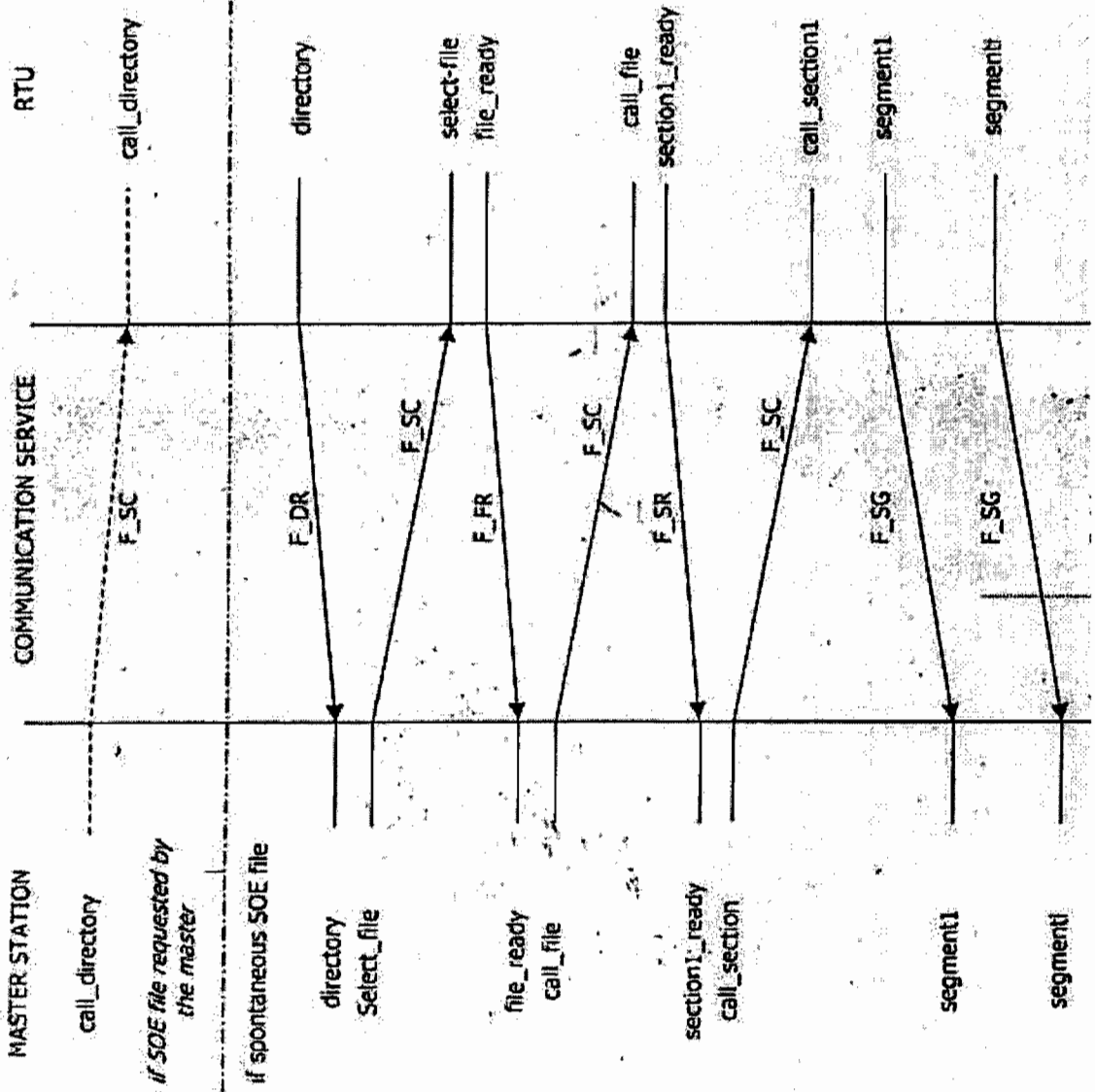

Figure 2. S900 File structure

For the SOE the file transfer procedure is used. The exchange of data is described in the IEC 870.5.5 document; chapter 6.12 and the message (ASDU) are described in the IEC 870.5.101 document, chap 7.3.6.



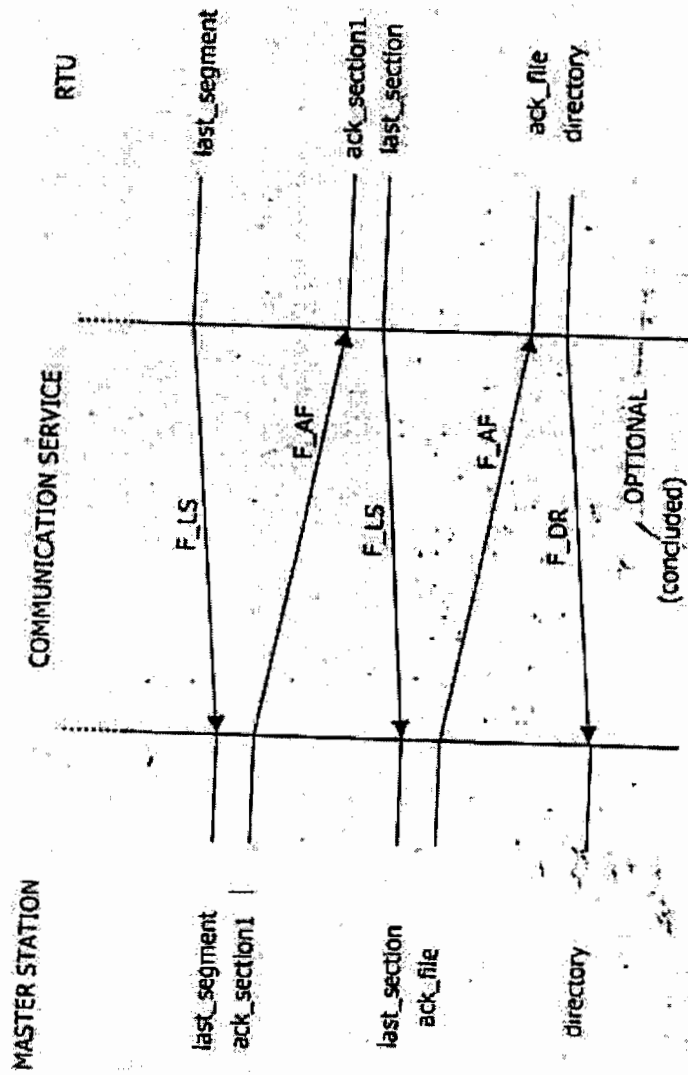

Figure 3. File transfer sequential procedure (monitor direction)

3.1.1.1.3 SOE file

For this project, we define a file by an identification part, a header part and an informational part. Each part has a length sub-part and a data sub-part.

$FILE = IDENTIFICATION + HEADER + INFORMATION$
 $IDENTIFICATION = LENGTH + DATA + [FILL]$
 $INFORMATION = LENGTH + DATA + [FILL]$

The field "LENGTH" is coded with 4 bytes and is rounded to a long word boundary. The field "DATA" is described on the next page.

3.1.1.1.4 SOE structure

The file used for SOE has a capacity of 1200 events (1200 if one configured master station, 600 if two configured master station, 400 if three configured master station). If the RTU is not polled a long time, and if the SOE file is full, the oldest event is deleted and replaced by a RS with the address zero and the new one is stored into the SOE circular file.

Individual points can be configured for the SOE recording. It means that for these points, when an event occurs, a message M_SP_NA_1, M_SP_TA_1, M_DP_NA_1, M_DP_TA_1 (change of status for single or double point) is sent to the control centre and it is also stored in the SOE file. For the others, the RTU sends only the change of status to the control centre.

Each RS could be configured as SOE or not SOE. RS are transmitted with time tag or not (it depends on a global parameter of database). The SOE files are sent through class 2. As it is described in document R2, RS changes of state with time tag are sent by class 1 and without time tag are sent by class 2.

On normal condition, when the file is < parameter2 > % full, the RTU sends to the control centre the ASDU directory (F_DR_NA_1). Then the control centre could request the SOE file from the RTU. This % limit is a parameter of the system (ranging from 25% to 95%, 25% is the default value). RTU keeps the SOE file until the last message of the file transfer is acquitted; after all the parts of the file are transmitted, all SOE records sent are deleted from this file (without any loss of new SOE record event) after receive an ASDU F_AF_NA_1 (ack_file) acknowledging the file transfer (compliant with IEC 670.5.5). But if the SOE file is overflow, the last transfer in progress will be lost.

Note(s): < parameter1 >, < parameter2 > are configurable parameters and could be easily changed using S900/CETT configuration.

The IEC file name for the SOE file is 255 (00FF hexadecimal).

The SOE file could be requested by the control centre by sending a select file ASDU directly.

The SOE file is empty at the starting of the RTU.

The file transfer for SOE should be completely redundant. It means it is possible to swap the communication line without any perturbation on the file transfer procedure: after a change of path, the file transfer should be continue at the point where it was before the change of path.

3.1.1.1.5 Structure of the SOE file

FILE = IDENTIFICATION + HEADER + INFORMATION

IDENTIFICATION = LENGTH + DATA + [FILL]

INFORMATION = LENGTH + DATA + [FILL]

IDENTIFICATION = LENGTH + DATA + [FILL]

LENGTH = 40 (4bytes)

DATA = name + version

name = 'SEQUENCE OF EVENTS' (32 bytes)

version = version with U18 format (1 byte)

[FILL] = 3 null bytes (3 bytes)

HEADER = LENGTH + DATA + [FILL]

LENGTH = 8 (4bytes)

DATA = number of SOE (2 bytes)

[FILL] = 2 null bytes (2 bytes)

INFORMATION = LENGTH + DATA + [FILL]

LENGTH = (10 * number of SOE) + 4, rounded to a longword boundary.

DATA = set of ATOMIC SOE.

ATOMIC-SOE = I/O address + status + time_stamp

I/O address = information object address (2 bytes)

status = SIQ or OIQ format (1 byte) with new SD flag

(0 = single/1 = double) on the BS1(4) Position.

time_stamp = CP56Time2a format (7 bytes)

[FILL] = 0 or 2 null bytes.

3.1.1.1 ATOMIC SOE structure

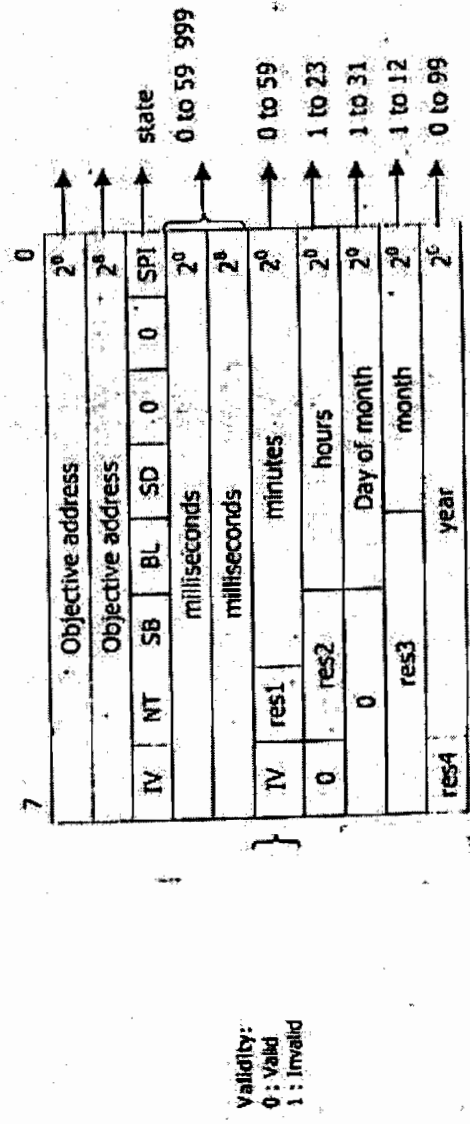
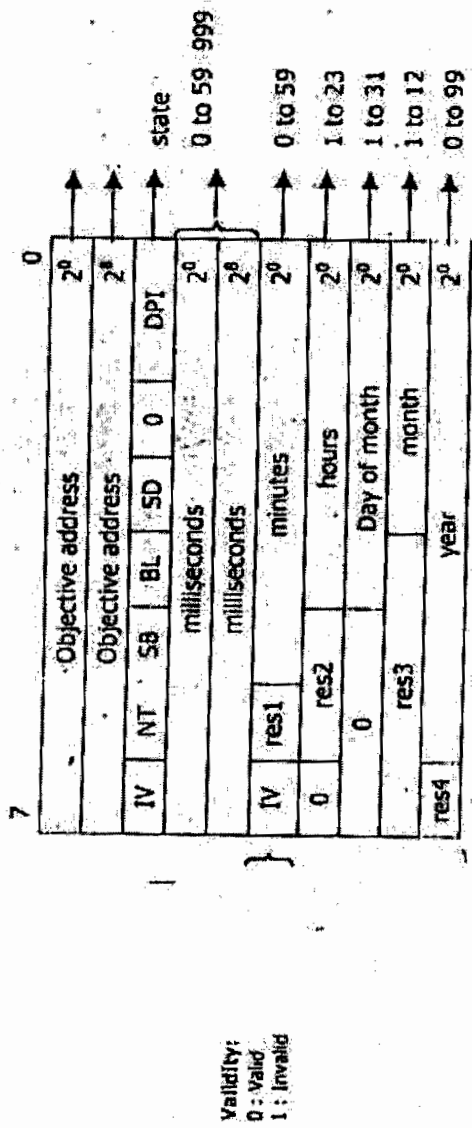

Figure 4. Atomic SOE (single point)



- State:
- DPI = 0 indeterminate state
 - DPI = 1 OFF (open)
 - DPI = 2 ON (closed)
 - DPI = 3 invalid
 - IV = 1 TS Invalid
 - 0 TS Valid
 - BL = 0 Irrelevant
 - SB = 0 Irrelevant
 - NT = 0 Irrelevant
 - SD = 0 (double point)

Figure 5. Atomic SOE (double point)

List of IO Points to be transmitted to RSCC

- a) MW and MVAR for all lines , transformers ,reactors and Capacitors
- b) Voltage of all buses
- c) Frequency of all 400Kv and 765kV Buses
- d) Frequency of one 220Kv Bus
- e) All Breakers
- f) All isolators
- g) Tap Position for all transformers
- h) Master protection signal for all feeders, transformers Units and Bus Bar
- i) Loss of Voltage signal for Bus bar
- j) All the points identified in point (e),(h) and (i) above as GPS Time stamped.
- k) Temperature value per substation.
- l) Any other point decided during detailed engineering

SECTION - II

ANNEXURE - B

Annexure-B

Specification of Line Current Differential Protection

1. Feeder Protection current differential relay with the following protection functions shall has to be provided under present scope:
 - i. High speed numerical current differential protection feeder protection suitable to work through directly connected fiber optics.
 - ii. The relay shall incorporate inter-tripping, VT Supervision functions and heavy duty contacts for tripping of the feeder circuit breaker as well as provide all flagging, alarms etc.
 - iii. The protection relay should be compatible with remote end in all respect i.e. relay, CT, communication etc. Any interface equipment required also should be included.
 - iv. Where the main relay does not have the teleprotection communication capability to work over directly connected fiber optic cables, in cases of long circuits, suitable amplifiers or other terminal equipment shall be provided at both the substations.

2. **The detailed specification of current differential relay is as under:**

The feeder Differential Current Protection shall comprise a well-proven high-speed phase segregated numerical current differential protection scheme, which shall be designed for the selective protection of the EHV network.

The current differential protection scheme shall comprise two relays, one at each end of the feeder. All related interfacing relays and wirings required for the scheme shall be included.

The bidder shall coordinate the requirements of the current differential relay with the communication system in order to ensure compatibility between the two systems.

The feeder differential current protection scheme to be provided shall have as a minimum the following main features:

- 1) Shall be a unit system of protection with back up features. The line differential relays for 400 kV feeders shall have distance back up function capable of being selected to function in parallel with the differential protection or activate automatically when the differential relay is out of service.
- 2) Shall have built signaling modules for communication with the remote end relay either via direct optical fiber cables or through multiplexers.
- 3) Shall have high-speed fault detection capability with typical relay operation time of less than 30 ms for 400kV faults.
- 4) Shall have high sensitivity for all types of faults.

Section: Project, Rev. 1 Sub- Station Package: Consultancy to TANTRANSCO

- 5) Shall detect and clear faults along the whole length of the feeder within the specified operating time when the remote end breaker is open or there is a weak in feed.
- 6) Shall remain stable for fault on a parallel feeder under subsequent current reversal in the healthy feeder due to slow opening of one of the faulty feeder's circuit breakers.
- 7) Shall not be affected by heavy load transfer, power swings, CT saturation, distorted primary currents and voltages, VT fuse failure, line charging currents external switching, arc or tower footing resistance, sudden power reversal, zero sequence mutual coupling, fault resistance and out of phase source at the two line terminals producing misleading apparent fault reactance, power frequency variations, collapse of voltage on the faulted phase(s), etc.
- 8) Shall have low burdens/low requirements on the CT's and VT's.
- 9) The line differential device address shall be settable and shall be suitable to set at least 99 different feeders.
- 10) Shall have features to clear close in faults at high speed in the event of failure of signaling channel.
- 11) Shall be complete with all test devices required to test f the relay's set values.
- 12) Shall have features to test at one end all the functions associated with the protection, without the presence of personnel at the remote end.
- 13) Shall have micro-processor based tripping logic
- 14) Shall have features to block relay in case of signaling channel failure or remote relay out of service / block or setting mismatch or dc failure etc., to avoid inadvertent tripping and shall produce alarm during blocking.
- 15) Shall have inter-tripping compliant with IEC60834-1 and IEC60834-2 respectively for signaling as appropriate.
- 16) CT supervision / VT Supervision shall be configured to initiate alarm locally and to sub-station automation system or event recorder as per requirement.
- 17) Shall have single pole/three pole tripping feature.
- 18) Shall have built-in SOTF logic feature.
- 19) Shall have features to block auto-reclose internally / externally at local end and facility to send blocking signals to remote end relay internally (through FO communication channels) during SOTF trips.
- 20) Shall have facility to configure signal transferred between local and remote end relays in the internal event recorder and disturbance recorder.
- 21) Shall have configurable time delayed thermal protection element.
- 22) The distance backup function in Line current differential relay shall have at least two distance backup protection elements.

The bidder shall also provide the following details:

- 1) Performance of relay under ct saturation during through faults.
- 2) Performance of relay under conditions of CT saturation for in zone faults.
- 3) Performance of relay during transient (jitter) and permanent changes in signaling propagation delays.

| | | | | | |
|-----------|----------|------|------|----------|------|
| REV. DATE | APPROVED | ZONE | DATE | APPROVED | ZONE |
| REV. DATE | APPROVED | ZONE | DATE | APPROVED | ZONE |
| REV. DATE | APPROVED | ZONE | DATE | APPROVED | ZONE |
| REV. DATE | APPROVED | ZONE | DATE | APPROVED | ZONE |
| REV. DATE | APPROVED | ZONE | DATE | APPROVED | ZONE |

NOA NO. - CC-CS/194-NR1/SS-2546/3/03/NOA-18/15/63 & 5164
 NAME OF PROJECT: EVALUATION OF POWER FROM LALPUR UNDER UPTEL CONSULTANCY SERVICES
 NAME OF CUSTOMER: POWER GRID CORPORATION OF INDIA LTD
 W.D.NO.:

STATUS OF DRAWINGS:
 APPROVED FOR CONSTRUCTION
 APPROVED FOR CONSTRUCTION
 APPROVED FOR CONSTRUCTION
 APPROVED FOR CONSTRUCTION
 APPROVED FOR CONSTRUCTION

DATE: 28.01.15
 CHECKED: [Signature]
 DESIGNED: [Signature]
 DRAWN: [Signature]
 PROJECT: TRANSMISSION PROJECTS DIVISION
 BRHARAT HEAVY ELECTRICALS LTD.
 13.10.14

REVISIONS:
 01: 28.01.15: APPROVED FOR CONSTRUCTION
 02: 28.01.15: APPROVED FOR CONSTRUCTION
 03: 28.01.15: APPROVED FOR CONSTRUCTION
 04: 28.01.15: APPROVED FOR CONSTRUCTION
 05: 28.01.15: APPROVED FOR CONSTRUCTION

REFERENCE DWG. NO. - SINGLE LINE DIAGRAM 765/400KV/5164 R-1
 TITLE: SINGLE LINE DIAGRAM 765/400KV/5164 R-1
 DWG. NO.:

LEGEND:
 # - CIRCUIT BREAKER WITH CONTROLLED SWITCHING DEVICE
 □ - CIRCUIT BREAKER WITHOUT CR
 □ - CIRCUIT BREAKER WITH CR
 / - 1-PHASE CONDUCTOR
 \ - 3-PHASE CONDUCTOR
 * - 3x1-PHASE EQUIPMENTS
 --- - FUTURE SCOPE
 --- - PRESENT SCOPE

NOTE:-
 01. NOMINAL SYSTEM VOLTAGE: 765KV
 02. HIGHEST SYSTEM VOLTAGE: 765KV
 03. CURRENT RATING (BUS BAR): 3000A
 04. SHORT CIRCUIT CURRENT RATING: 40 KA FOR 1 SEC.
 05. PULL AWE IMPULSE WITHSTAND VOLTAGE: 2100 KVP
 06. SWITCHING IMPULSE WITHSTAND VOLTAGE: 1650 KVP
 07. POWER FREQUENCY WITHSTAND VOLTAGE: 830 KV
 08. CREEPAGE: 25mm/KV
 09. SYSTEM BARTHING EFFECTIVELY BARTHING
 10. 765/400 KV TRANSFORMER & 765 W/REACTORS ARE NOT IN BHEL SCOPE.
 11. TERMINAL FORMATION, AUX. BUS FOR INTERCONNECTION ARRANGEMENT OF SPARE TRANSFORMER AND REACTOR IS NOT UNDER BHEL'S SCOPE.
 12. FSC SYSTEM IN LALPUR I & II LINE IS NOT UNDER BHEL'S SCOPE.

| Core Current Ratio | Accuracy | Output | Min kV (V) | Max RCT | Max In kV (V) | Purpose |
|--------------------|-----------------|--------|------------|---------|---------------|---------------------------|
| 1 | 3000-2000-500/1 | TPS | 3000 | 2000 | 500 | BUS DIFF. CHECK |
| 2 | 3000-2000-500/1 | TPS | 3000 | 2000 | 500 | BUS DIFF. MAIN |
| 3 | 3000-2000-500/1 | TPS | 3000 | 2000 | 500 | BUS DIFF. CHECK |
| 4 | 3000-2000-500/1 | TPS | 3000 | 2000 | 500 | BUS DIFF. MAIN |
| 5 | 3000-2000-500/1 | TPS | 3000 | 2000 | 500 | TRANS. DIFF. LINE PROTIN |
| 6 | 3000-2000-500/1 | TPS | 3000 | 2000 | 500 | TRANS. BACKUP LINE PROTIN |

| Ratio | Class | Capacitance |
|----------------------------|-------------|-------------|
| 765KV / 110V / 110V / 110V | Class - I | 4400 pF |
| 400KV / 110V / 110V / 110V | Class - II | 4400 pF |
| 30 ON 3000/1 TAP | Class - III | 4400 pF |

| Ratio | Class | Capacitance |
|----------------------------|-------------|-------------|
| 765KV / 110V / 110V / 110V | Class - I | 4400 pF |
| 400KV / 110V / 110V / 110V | Class - II | 4400 pF |
| 30 ON 3000/1 TAP | Class - III | 4400 pF |

| Core Current Ratio | Accuracy | Output | Min kV (V) | Max RCT | Max In kV (V) | Purpose |
|--------------------|-----------------|--------|------------|---------|---------------|---------------------------|
| 1 | 3000-2000-500/1 | TPS | 3000 | 2000 | 500 | BUS DIFF. CHECK |
| 2 | 3000-2000-500/1 | TPS | 3000 | 2000 | 500 | BUS DIFF. MAIN |
| 3 | 3000-2000-500/1 | TPS | 3000 | 2000 | 500 | BUS DIFF. CHECK |
| 4 | 3000-2000-500/1 | TPS | 3000 | 2000 | 500 | BUS DIFF. MAIN |
| 5 | 3000-2000-500/1 | TPS | 3000 | 2000 | 500 | TRANS. DIFF. LINE PROTIN |
| 6 | 3000-2000-500/1 | TPS | 3000 | 2000 | 500 | TRANS. BACKUP LINE PROTIN |

| Ratio | Class | Capacitance |
|----------------------------|-------------|-------------|
| 765KV / 110V / 110V / 110V | Class - I | 4400 pF |
| 400KV / 110V / 110V / 110V | Class - II | 4400 pF |
| 30 ON 3000/1 TAP | Class - III | 4400 pF |

| Ratio | Class | Capacitance |
|----------------------------|-------------|-------------|
| 765KV / 110V / 110V / 110V | Class - I | 4400 pF |
| 400KV / 110V / 110V / 110V | Class - II | 4400 pF |
| 30 ON 3000/1 TAP | Class - III | 4400 pF |

| Item Description | QTY | SYMBOL |
|--------------------------|-----|--------|
| 800KV, 3000A CT (6 CORE) | 6 | |
| 800KV, 3000A CT (6 CORE) | 5 | |
| 800KV, 3000A CT (6 CORE) | 4 | |
| 800KV, 3000A CT (6 CORE) | 3 | |
| 800KV, 3000A CT (6 CORE) | 2 | |
| 800KV, 3000A CT (6 CORE) | 1 | |

| Item Description | QTY | SYMBOL |
|--------------------------|-----|--------|
| 800KV, 3000A CT (6 CORE) | 6 | |
| 800KV, 3000A CT (6 CORE) | 5 | |
| 800KV, 3000A CT (6 CORE) | 4 | |
| 800KV, 3000A CT (6 CORE) | 3 | |
| 800KV, 3000A CT (6 CORE) | 2 | |
| 800KV, 3000A CT (6 CORE) | 1 | |

| Item Description | QTY | SYMBOL |
|--------------------------|-----|--------|
| 800KV, 3000A CT (6 CORE) | 6 | |
| 800KV, 3000A CT (6 CORE) | 5 | |
| 800KV, 3000A CT (6 CORE) | 4 | |
| 800KV, 3000A CT (6 CORE) | 3 | |
| 800KV, 3000A CT (6 CORE) | 2 | |
| 800KV, 3000A CT (6 CORE) | 1 | |

| Item Description | QTY | SYMBOL |
|--------------------------|-----|--------|
| 800KV, 3000A CT (6 CORE) | 6 | |
| 800KV, 3000A CT (6 CORE) | 5 | |
| 800KV, 3000A CT (6 CORE) | 4 | |
| 800KV, 3000A CT (6 CORE) | 3 | |
| 800KV, 3000A CT (6 CORE) | 2 | |
| 800KV, 3000A CT (6 CORE) | 1 | |

| Item Description | QTY | SYMBOL |
|--------------------------|-----|--------|
| 800KV, 3000A CT (6 CORE) | 6 | |
| 800KV, 3000A CT (6 CORE) | 5 | |
| 800KV, 3000A CT (6 CORE) | 4 | |
| 800KV, 3000A CT (6 CORE) | 3 | |
| 800KV, 3000A CT (6 CORE) | 2 | |
| 800KV, 3000A CT (6 CORE) | 1 | |

| Item Description | QTY | SYMBOL |
|--------------------------|-----|--------|
| 800KV, 3000A CT (6 CORE) | 6 | |
| 800KV, 3000A CT (6 CORE) | 5 | |
| 800KV, 3000A CT (6 CORE) | 4 | |
| 800KV, 3000A CT (6 CORE) | 3 | |
| 800KV, 3000A CT (6 CORE) | 2 | |
| 800KV, 3000A CT (6 CORE) | 1 | |

| Item Description | QTY | SYMBOL |
|--------------------------|-----|--------|
| 800KV, 3000A CT (6 CORE) | 6 | |
| 800KV, 3000A CT (6 CORE) | 5 | |
| 800KV, 3000A CT (6 CORE) | 4 | |
| 800KV, 3000A CT (6 CORE) | 3 | |
| 800KV, 3000A CT (6 CORE) | 2 | |
| 800KV, 3000A CT (6 CORE) | 1 | |

| Item Description | QTY | SYMBOL |
|--------------------------|-----|--------|
| 800KV, 3000A CT (6 CORE) | 6 | |
| 800KV, 3000A CT (6 CORE) | 5 | |
| 800KV, 3000A CT (6 CORE) | 4 | |
| 800KV, 3000A CT (6 CORE) | 3 | |
| 800KV, 3000A CT (6 CORE) | 2 | |
| 800KV, 3000A CT (6 CORE) | 1 | |

| Item Description | QTY | SYMBOL |
|--------------------------|-----|--------|
| 800KV, 3000A CT (6 CORE) | 6 | |
| 800KV, 3000A CT (6 CORE) | 5 | |
| 800KV, 3000A CT (6 CORE) | 4 | |
| 800KV, 3000A CT (6 CORE) | 3 | |
| 800KV, 3000A CT (6 CORE) | 2 | |
| 800KV, 3000A CT (6 CORE) | 1 | |

| Item Description | QTY | SYMBOL |
|--------------------------|-----|--------|
| 800KV, 3000A CT (6 CORE) | 6 | |
| 800KV, 3000A CT (6 CORE) | 5 | |
| 800KV, 3000A CT (6 CORE) | 4 | |
| 800KV, 3000A CT (6 CORE) | 3 | |
| 800KV, 3000A CT (6 CORE) | 2 | |
| 800KV, 3000A CT (6 CORE) | 1 | |

| Item Description | QTY | SYMBOL |
|--------------------------|-----|--------|
| 800KV, 3000A CT (6 CORE) | 6 | |
| 800KV, 3000A CT (6 CORE) | 5 | |
| 800KV, 3000A CT (6 CORE) | 4 | |
| 800KV, 3000A CT (6 CORE) | 3 | |
| 800KV, 3000A CT (6 CORE) | 2 | |
| 800KV, 3000A CT (6 CORE) | 1 | |

| Item Description | QTY | SYMBOL |
|--------------------------|-----|--------|
| 800KV, 3000A CT (6 CORE) | 6 | |
| 800KV, 3000A CT (6 CORE) | 5 | |
| 800KV, 3000A CT (6 CORE) | 4 | |
| 800KV, 3000A CT (6 CORE) | 3 | |
| 800KV, 3000A CT (6 CORE) | 2 | |
| 800KV, 3000A CT (6 CORE) | 1 | |

| Item Description | QTY | SYMBOL |
|--------------------------|-----|--------|
| 800KV, 3000A CT (6 CORE) | 6 | |
| 800KV, 3000A CT (6 CORE) | 5 | |
| 800KV, 3000A CT (6 CORE) | 4 | |
| 800KV, 3000A CT (6 CORE) | 3 | |
| 800KV, 3000A CT (6 CORE) | 2 | |
| 800KV, 3000A CT (6 CORE) | 1 | |

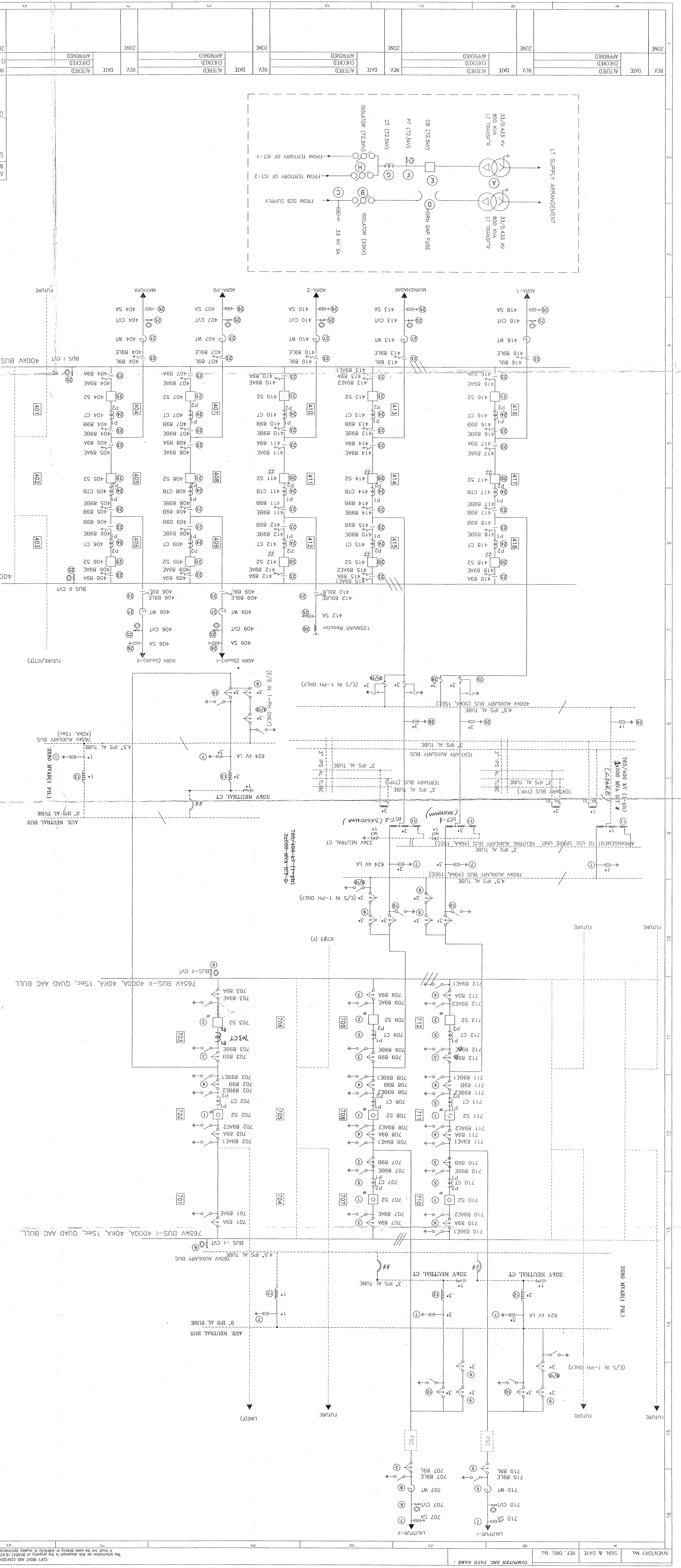

| Inventory No. | Sign. & Date | Ref. Brg. No. | Comp. Dwg. Part Name |
|---------------|--------------|---------------|----------------------|
| | | | |
| | | | |
| | | | |
| | | | |
| | | | |



LEGEND

- FENCE
- 765KV STRUCTURE UNDER PRESENT SCOPE
- 765KV STRUCTURE UNDER FUTURE SCOPE
- 400 KV STRUCTURE UNDER FUTURE SCOPE
- 3.75 M CONCRETE ROAD
- 5.5 M CONCRETE ROAD
- BOUNDARY WALL

1. ALL DIMENSIONS ARE IN MM.
2. 765KV TRANSFORMERS & REACTORS ARE IN SEPARATE PACKAGE. ALL CONNECTION FROM SA TO TRANSFORMER & REACTORS BUSHING THROUGH OVERHEAD CONDUCTOR ARE IN THE SCOPE OF CONTRACTOR
3. LOCATION OF ALL BUILDINGS ARE INDICATIVE ONLY, BASED ON TENTATIVE PLOT PLAN AND NOS. OF FEEDERS INDICATED IN DRAWING. CONTRACTOR MAY DESIGN AND OPTIMISE THE LAYOUT AND BULDINGS IN LINE WITH TECHNICAL SPECIFICATION.
4. DESTINATION OF FEEDERS MARKED AS FUTURE ARE INDICATIVE ONLY.
5. LOCATIONS OF ROADS, RAIL CUM ROAD INSIDE THE SUB STATION ARE TENTATIVE AND SHALL BE FINALISED DURING DETAILED ENGG.
6. TRANSMISSON LINE TOWERS INSIDE S/S SHALL BE LOCATED AFTER THE CLEARANCE OF CORPORATE ENGG.
7. FENCE TO BE PROVIDED BETWEEN POINTS "AB" & "CDEFG".
EARTHMAT TO BE LAID IN AREA COVERED BY POINTS A B G F E D C

FOR TENDER PURPOSE ONLY

POWER GRID CORPORATION OF INDIA LIMITED
(A GOVERNMENT OF INDIA ENTERPRISE)

PROJECT: EVACUATION OF POWER FROM LALITPUR TPP UNDER UPPTCL CONSULTANCY SERVICES

SUBSTATION: 765/400KV AGRA (UPPTCL) SUBSTATION

TITLE: GENERAL ARRANGEMENT DRAWING
765/400KV AGRA (UPPTCL) AIS SUBSTATION

| | | | | |
|--------------------|----------|-------|--------------------------------------|------|
| DRAWN BY | DATE | SCALE | DRG.NO. | REV. |
| <i>[Signature]</i> | MAR 2014 | NTS | C/ENGG-SS/NR-1/765-400KV /AGRA_UP/GA | 0 |

| | | | |
|-----------------------|------------------------------|-----------------------------|------------------------|
| <i>[Signature]</i> | <i>[Signature]</i> | <i>[Signature]</i> | <i>[Signature]</i> |
| CHECKED (ENGG-S/S) | RECOMMENDED BY (ENGG-S/S) | APPROVED BY (ENGG-CIVIL) | ED (ENGG-S/S & T/L) |

SECTION –III OF TECHNICAL SPECIFICATION

SECTION-3

PROJECT DETAILS & GENERAL SPECIFICATION

SITE INFORMATION

| | Particular | Details |
|------------------------|--|---|
| a) | Owner | UP POWER TRANSMISSION CORPORATION Ltd |
| b) | Customer | POWERGRID |
| c) | Project Title | 765kV/400kV Agra UPPTCL (New)Substation |
| d) | Location | AGRA |
| e) | Transport Facilities | RAOD/TRAIN |
| SITE CONDITIONS | | |
| a) | Max. ambient air temp. | 50°C |
| b) | Min. ambient air temp. | 0°C |
| c) | Max. design ambient temp. | 50°C |
| d) | Design reference temp. | 50°C |
| e) | Average Humidity | Max. 100% |
| f) | Special corrosion conditions | No |
| g) | Solar Radiation | 1.2kW/sqmtr |
| h) | Atmospheric UV radiation | High |
| i) | Altitude above sea level | Less than 1000meter |
| j) | Pollution Severity | High Pollution level (25mm/kV) |
| k) | Seismic Zone | As per the seismic zone defined in the relevant BIS but not less than 0.3g horizontal |
| WIND DATA | | |
| | Wind velocity | As per IS |
| | Average No. of thunderstorm days per annum | As per IS |

SECTION –III OF TECHNICAL SPECIFICATION

1.0 GENERAL

This Chapter covers Technical Requirements and requirements of auxiliary items.

- a) Equipment furnished shall be complete in every respect with all mountings, fittings, fixtures and standard accessories normally provided with such equipment and/or needed for erection, completion and safe operation of the equipment as required by applicable codes unless included in the list of exclusions.
- b) Material and components not specifically stated in this specification but which are necessary for satisfactory operation of the equipment and accessories specified in this specification shall be deemed to be included unless specifically excluded and shall be supplied at no extra cost.
- c) Whenever a material or article is specified or described by the name of a particular brand, manufacturer or vendor, the specific name mentioned shall be understood as establishing type, function and quality and not as limiting competition.
- d) In case any Deviation Schedule, Bid Proposal Sheet, Schedule of Data Requirements (DRS), test reports or any other document/information are not furnished along-with the bid, the bid is liable to be rejected. Unless brought out clearly, the Bid will be deemed to conform to the specification scrupulously. All deviations from the specification shall be clearly brought out in the respective deviation schedule.

Auxiliary supplies as described below would be available at site.

| Normal Voltage (Volts) | Variation in voltage | Frequency (Hz) | Phase | Neutral connection |
|------------------------|----------------------|----------------|-------------|--|
| 415 | + 10 % | 50 + 5 % | 3 Ph- 4wire | Solidly earthed |
| 240 | + 10 % | 50 + 5 % | 1 Ph-2wire | Solidly earthed |
| 220 | + 10 % | DC | | Isolated(2 wire system) |
| 48 | | DC | | Isolated(2 wire system) (+ Earthed) |

- f) The Bidder shall clearly indicate in the bid, the specific standards in accordance with which the works will be carried out.
- g) The equipment must be new, of highest grade, the best quality of their kind, to best engineering practice and latest state of art, and in accordance with purpose for which they are intended and ensure satisfactory performance throughout the service life.

SECTION –III OF TECHNICAL SPECIFICATION

- h) All similar parts of the equipment shall be made to gauge and shall be interchangeable with and shall be made of same materials and workmanship as the corresponding parts of the equipment. Where feasible, common components, units shall be employed in different pieces of equipment in order to optimize the spare part stock-up and utilization.
- i) The requirement regarding external RIV as specified for equipment shall include the terminal fittings and the equipment shall have been tested preferably with fittings, if any.

2.0 SERVICES TO BE PERFORMED BY THE EQUIPMENT BEING FURNISHED

- a) The equipment furnished under this specification shall perform all its functions and operate satisfactorily without showing undue strain, restrike etc.
- b) The equipment shall be able to withstand forces due to wind load, short circuit, system over voltages, fluctuations, frequency variations etc., all forces considered together.

3.0 SUPPORT STRUCTURES (If in the scope of Bidder)

- a) The support structures should be hot dip galvanised with minimum 610 gram/m² net of zinc.
- b) The design calculations taking into account the environmental conditions of the substations shall be furnished for sizing of the structures.

4.0 STANDARDS

- a) The equipment to be furnished under this specification shall conform to latest issue with all amendments of standard specified under respective Chapters of this Specification. The Bidder shall note that standards mentioned in the specification are not mutually exclusive or complete in themselves, but intended to compliment each other. The bidder shall also note that list of standards presented in this specification is not complete. Whenever necessary the list of standards shall be considered in conjunction with specific IS/IEC. When the specific requirements stipulated in the specifications exceed or differ than those required by the applicable standards, the stipulation of the specification shall take precedence.
- b) Other internationally accepted standards which ensure equivalent or better performance than that specified in the standards referred shall also be accepted.
- c) In case governing standards for the equipment is different from IS or IEC, the salient points of difference shall be clearly brought out in additional information schedule alongwith English language version of standard or relevant extract of the same. The equipment conforming to standards other than IS/IEC shall be subject to POWERGRID's approval.

5.0 ENGINEERING DATA AND DRAWINGS

- 5.1 The list of drawings/documents which are to be submitted to the Purchaser shall be discussed and finalised by the Purchaser at the time of award. The supplier shall necessarily submit all the drawings/ documents unless anything is waived.
- 5.2 The Contractor shall submit 4 (four) sets of drawings/ design documents /data / detailed bill of quantity and 1 (one) set of test reports for the approval of the Purchaser. The contractor shall also submit the softcopy of the above documents in addition to hardcopy.

SECTION –III OF TECHNICAL SPECIFICATION

5.3 Drawings

- 5.3.1 All drawings submitted by the Contractor shall be in sufficient detail to indicate the type, size, arrangement, material description, Bill of Materials, weight of each component, break-up for packing and shipment, dimensions, internal & the external connections, fixing arrangement required and any other information specifically requested in the specifications.
- 5.3.2 Drawings submitted by the Contractor shall be clearly marked with the name of the Purchaser, the unit designation, the specifications title, the specification number and the name of the Project. POWERGRID has standardized a large number of drawings/documents of various make including type test reports which can be used for all projects having similar requirements and in such cases no project specific approval (except for list of applicable drawings alongwith type test reports) is required. However, distribution copies of standard drawings/documents shall be submitted as per provision of the contract. All titles, noting, markings and writings on the drawing shall be in English. All the dimensions should be in SI units.
- 5.3.3 The review of these data by the Purchaser will cover only general conformance of the data to the specifications and documents, interfaces with the equipment provided under the specifications, external connections and of the dimensions which might affect substation layout. This review by the Purchaser may not indicate a thorough review of all dimensions, quantities and details of the equipment, materials, any devices or items indicated or the accuracy of the information submitted. This review and/or approval by the Purchaser shall not be considered by the Contractor, as limiting any of his responsibilities and liabilities for mistakes and deviations from the requirements, specified under these specifications and documents.
- 5.4 All manufacturing and fabrication work in connection with the equipment prior to the approval of the drawings shall be at the Contractor's risk. The Contractor may make any changes in the design which are necessary to make the equipment conform to the provisions and intent of the Contract and such changes will again be subject to approval by the Purchaser. Approval of Contractor's drawing or work by the Purchaser shall not relieve the contractor of any of his responsibilities and liabilities under the Contract.
- 5.5 All engineering data submitted by the Contractor after final process including review and approval by the Purchaser shall form part of the Contract Document and the entire works performed under these specifications shall be performed in strict conformity, unless otherwise expressly requested by the Purchaser in Writing.

5.7 Approval Procedure

The scheduled dates for the submission of the drawings as well as for, any data/information to be furnished by the Purchaser would be discussed and finalised at the time of award. The following schedule shall be followed generally for approval and for providing final documentation.

- | | |
|---|---|
| i) Approval/comments/ Purchaser on initial | As per agreed by schedule submission |
| ii) Resubmission (whenever) | Within 3 (three) weeks from date of comments required) |
| iii) Approval or comments | Within 3 (three) weeks of receipt of resubmission. |

SECTION –III OF TECHNICAL SPECIFICATION

- | | | |
|-------|---|---|
| iv) | Furnishing of distribution copies (5 hard copies per substation and one scanned copy (pdf format) for Corporate Centre) | 2 weeks from the date of approval |
| v) | Furnishing of distribution copies of test reports | |
| (a) | Type test reports (one scanned softcopy in pdf format per substation plus one for corporate centre & one hardcopy per substation) | 2 weeks from the date of final approval |
| (b) | Routine Test Reports (one copy for each substation) | -do- |
| vi) | Furnishing of instruction/ copies per substation and one softcopy (pdf format) for corporate centre & per substation) | As per agreed schedule operation manuals (2 |
| (vii) | As built drawings (two sets of per substation & one softcopy (pdf format) for corporate centre & per substation) | On completion of entire works hardcopy |

NOTE :

- (1) The supplier may please note that all resubmissions must incorporate all comments given in the earlier submission by BHEL/POWERGRID or adequate justification for not incorporating the same must be submitted failing which the submission of documents is likely to be returned.
- (2) All drawings should be submitted in softcopy form, however substation design drawings like SLD, GA, all layouts etc. shall also be submitted in AutoCAD Version. SLD, GA & layout drawings shall be submitted for the entire substation in case of substation extension also.
- (3) The instruction Manuals shall contain full details of drawings of all equipment being supplied under this contract, their exploded diagrams with complete instructions for storage, handling, erection, commissioning, testing, operation, trouble shooting, servicing and overhauling procedures.
- (4) If after the commissioning and initial operation of the substation, the instruction manuals require any modifications/ additions/changes, the same shall be incorporated and the updated final instruction manuals shall be submitted by the supplier to BHEL/POWERGRID.
- (5) The manufacturer shall furnish to the Purchaser catalogues of spare parts.
- (6) All As-built drawings/documents shall be certified by site indicating the changes before final submission.

6.0 MATERIAL WORKMANSHIP

6.1 General Requirement

- 6.1.1 Where the specification does not contain references to workmanship, equipment, materials and components of the covered equipment, it is essential that the same must be new, of highest grade of the best quality of their kind, conforming to best engineering

SECTION –III OF TECHNICAL SPECIFICATION

practice and suitable for the purpose for which they are intended.

- 6.1.2 In case where the equipment, materials or components are indicated in the specification as “similar” to any special standard, the Purchaser shall decide upon the question of similarity. When required by the specification or when required by the Purchaser the Contractor shall submit, for approval, all the information concerning the materials or components to be used in manufacture. Machinery, equipment, materials and components supplied, installed or used without such approval shall run the risk of subsequent rejection, it being understood that the cost as well as the time delay associated with the rejection shall be borne by the supplier.
- 6.1.3 The design of the Works shall be such that installation, future expansions, replacements and general maintenance may be undertaken with a minimum of time and expenses. Each component shall be designed to be consistent with its duty and suitable factors of safety, subject to mutual agreements. All joints and fastenings shall be devised, constructed and documented so that the component parts shall be accurately positioned and restrained to fulfill their required function. In general, screw threads shall be standard metric threads. The use of other thread forms will only be permitted when prior approval has been obtained from the BHEL/POWERGRID.
- 6.1.4 Whenever possible, all similar part of the Works shall be made to gauge and shall also be made interchangeable with similar parts. All spare parts shall also be interchangeable and shall be made of the same materials and workmanship as the corresponding parts of the Equipment supplied under the Specification. Where feasible, common component units shall be employed in different pieces of equipment in order to minimize spare parts stocking requirements. All equipment of the same type and rating shall be physically and electrically interchangeable.
- 6.1.5 All materials and equipment shall be installed in strict accordance with the manufacturer’s recommendation(s). Only first-class work in accordance with the best modern practices will be accepted. Installation shall be considered as being the erection of equipment at its permanent location. This, unless otherwise specified, shall include unpacking, cleaning and lifting into position, grouting, levelling, aligning, coupling of or bolting down to previously installed equipment bases/foundations, performing the alignment check and final adjustment prior to initial operation, testing and commissioning in accordance with the manufacturer’s tolerances, instructions and the Specification. All factory assembled rotating machinery shall be checked for alignment and adjustments made as necessary to re-establish the manufacturer’s limits suitable guards shall be provided for the protection of personnel on all exposed rotating and / or moving machine parts and shall be designed for easy installation and removal for maintenance purposes. The spare equipment(s) shall be installed at designated locations and tested for healthiness.
- 6.1.6 The supplier shall apply oil and grease of the proper specification to suit the machinery, as is necessary for the installation of the equipment. Lubricants used for installation purposes shall be drained out and the system flushed through where necessary for applying the lubricant required for operation. The supplier shall apply all operational lubricants to the equipment installed by him.
- 6.1.7 All oil, grease and other consumables used in the Works/ Equipment shall be purchased in India unless the Contractor has any special requirement for the specific application of a type of oil or grease not available in India. In such is the case he shall declare in the proposal, where such oil or grease is available. He shall help POWERGRID in establishing equivalent Indian make and Indian Contractor. The same

SECTION –III OF TECHNICAL SPECIFICATION

shall be applicable to other consumables too.

- 6.1.8 Corona and radio interference voltage test and seismic withstand test (for 132kV and above voltage level) procedures for equipments shall be in line with the procedure given at Annexure-A and B respectively.

6.2 Provisions For Exposure to Hot and Humid climate

Outdoor equipment supplied under the specification shall be suitable for service and storage under tropical conditions of high temperature, high humidity, heavy rainfall and environment favourable to the growth of fungi and mildew. The indoor equipments located in non-air conditioned areas shall also be of same type.

6.2.1 Space Heaters

- 6.2.1.1 The heaters shall be suitable for continuous operation at 240V as supply voltage. On-off switch and fuse shall be provided.

- 6.2.1.2 One or more adequately rated thermostatically connected heaters shall be supplied to prevent condensation in any compartment. The heaters shall be installed in the compartment and electrical connections shall be made sufficiently away from below the heaters to minimize deterioration of supply wire insulation. The heaters shall be suitable to maintain the compartment temperature to prevent condensation.

- 6.2.1.3 Suitable anti condensation heaters with the provision of thermostat shall be provided.

6.2.2 FUNGI STATIC VARNISH

Besides the space heaters, special moisture and fungus resistant varnish shall be applied on parts which may be subjected or predisposed to the formation of fungi due to the presence or deposit of nutrient substances. The varnish shall not be applied to any surface of part where the treatment will interfere with the operation or performance of the equipment. Such surfaces or parts shall be protected against the application of the varnish.

6.2.3 Ventilation opening

Wherever ventilation is provided, the compartments shall have ventilation openings with fine wire mesh of brass to prevent the entry of insects and to reduce to a minimum the entry of dirt and dust. Outdoor compartment openings shall be provided with shutter type blinds and suitable provision shall be made so as to avoid any communication of air / dust with any part in the enclosures of the Control Cabinets, Junction boxes and Marshalling Boxes, panels etc.

6.2.4 Degree of Protection

The enclosures of the Control Cabinets, Junction boxes and Marshalling Boxes, panels etc. to be installed shall provide degree of protection as detailed here under:

- a) Installed out door: IP- 55
- b) Installed indoor in air conditioned area: IP-31
- c) Installed in covered area: IP-52
- d) Installed indoor in non air conditioned area where possibility of entry of water is limited: IP-41.
- e) For LT Switchgear (AC & DC distribution Boards) : IP-52

The degree of protection shall be in accordance with IS:13947 (Part-I) / IEC-60947(Part-I) / IS 12063 / IEC-60529. Type test report for degree of protection test, shall be submitted for approval.

SECTION –III OF TECHNICAL SPECIFICATION

6.3 RATING PLATES, NAME PLATES AND LABELS

Each main and auxiliary item of substation is to have permanently attached to it in a conspicuous position a rating plate of non-corrosive material upon which is to be engraved manufacturer's name, year of manufacture, equipment name, type or serial number together with details of the loading conditions under which the item of substation in question has been designed to operate, and such diagram plates as may be required by the Purchaser. The rating plate of each equipment shall be according to IEC requirement.

All such nameplates, instruction plates, rating plates of transformers, reactors, CB, CT, CVT, SA, Isolators, C & R panels and PLCC equipments shall be bilingual with Hindi inscription first followed by English. Alternatively two separate plates one with Hindi and the other with English inscriptions may be provided.

6.4 FIRST FILL OF CONSUMABLES, OIL AND LUBRICANTS

All the first fill of consumables such as oils, lubricants, filling compounds, touch up paints, soldering/brazing material for all copper piping of circuit breakers and essential chemicals etc. which will be required to put the equipment covered under the scope of the specifications, into successful Operation, shall be furnished by the supplier unless specifically excluded under the exclusions in these specifications and documents.

7.0 DESIGN IMPROVEMENTS / COORDINATION

- 7.1 The bidder shall note that the equipment offered by him in the bid only shall be accepted for supply. However, the Purchaser or the Contractor may propose changes in the specification of the equipment or quality thereof and if the Purchaser & contractor agree upon any such changes, the specification shall be modified accordingly.
- 7.2 If any such agreed upon change is such that it affects the price and schedule of completion, the parties shall agree in writing as to the extent of any change in the price and/or schedule of completion before the Contractor proceeds with the change. Following such agreement, the provision thereof, shall be deemed to have been amended accordingly.
- 7.3 The supplier shall be responsible for the selection and design of appropriate equipments to provide the best co-ordinated performance of the entire system. The basic design requirements are detailed out in this Specification. The design of various components, sub-assemblies and assemblies shall be so done that it facilitates easy field assembly and maintenance.
- 7.4 The supplier has to coordinate designs and terminations with the agencies (if any) who are Consultants/Contractor for the Purchaser. The names of agencies shall be intimated to the successful bidders.
- 7.5 The supplier will be called upon to attend design co-ordination meetings with the Engineer, other Contractor's and the Consultants of the Purchaser (if any) during the period of Contract. The Contractor shall attend such meetings at his own cost at POWERGRID Corporate Centre, Gurgaon (Haryana) or at mutually agreed venue as and when required and fully cooperate with such persons and agencies involved during those discussions.

8.0 QUALITY ASSURANCE PROGRAMME

- 8.1 To ensure that the equipment and services under the scope of this Contract whether manufactured or performed within the supplier's Works or at his Sub-contractor's premises or at the Purchaser's site or at any other place of Work are in

SECTION –III OF TECHNICAL SPECIFICATION

accordance with the specifications, the supplier shall adopt suitable quality assurance programme to control such activities at all points necessary. The detailed programme shall be submitted by the contractor after the award for reference. A quality assurance programme of the supplier shall generally cover the following:

- (a) His organisation structure for the management and implementation of the proposed quality assurance programme;
- (b) Documentation control system;
- (c) Qualification data for bidder's key personnel;
- (d) The procedure for purchases of materials, parts components and selection of sub-Contractor's services including vendor analysis, source inspection, incoming raw material inspection, verification of material purchases etc.
- (e) System for shop manufacturing and site erection controls including process controls and fabrication and assembly control;
- (f) Control of non-conforming items and system for corrective actions;
- (g) Inspection and test procedure both for manufacture and field activities.
- (h) Control of calibration and testing of measuring instruments and field activities;
- (i) System for indication and appraisal of inspection status;
- (j) System for quality audits;
- (k) System for authorising release of manufactured product to the Purchaser.
- (l) System for maintenance of records;
- (m) System for handling storage and delivery; and
- (n) A quality plan detailing out the specific quality control measures and procedures adopted for controlling the quality characteristics relevant to each item of equipment furnished and/or services rendered.

POWERGRID/BHEL or his duly authorised representative reserves the right to carry out quality audit and quality surveillance of the system and procedure of the supplier/his vendor's quality management and control activities.

8.2 Quality Assurance Documents

The supplier would be required to submit all the Quality Assurance Documents as stipulated in the Quality Plan at the time of POWERGRID/BHEL inspection of equipment/material

9.0 TYPE TESTING, INSPECTION, TESTING & INSPECTION CERTIFICATE

- 9.1 All equipment being supplied shall conform to type tests as per technical specification and shall be subject to routine tests in accordance with requirements stipulated under respective sections.
- 9.2 The reports for all type tests as per technical specification shall be furnished by the supplier alongwith equipment / material drawings. However, type test reports of similar equipments/ material already accepted in POWERGRID shall be applicable for all project with similar requirement. The type tests conducted earlier should have either been conducted in accredited laboratory (accredited based on ISO / IEC Guide 25

SECTION –III OF TECHNICAL SPECIFICATION

/ 17025 or EN 45001 by the national accreditation body of the country where laboratory is located) or witnessed by POWERGRID or representative authorized by POWERGRID or Utility or representative of accredited test lab or reputed consultant.

The test reports submitted shall be of the tests conducted within last 10 (ten) years prior to the date of bid opening i.e. 26.08.11. In case the test reports are of the test conducted earlier than 10 (ten) years prior to the date of bid opening, the contractor shall repeat these test(s) at no extra cost to BHEL.

However, in case of instrument transformers, the following type tests should have been conducted within 5 (five) years prior to the date of bid opening.

- i) Lightning Impulse Test
- ii) Switching Impulse Test
- iii) Multiple Chopped Impulse Test (For CT)
- iv) Chopped Impulse Test (For CVT)

In case the test reports are of these tests (for instrument transformers) as mentioned above are conducted earlier than 5 (five) years prior to the date of bid opening i.e. 26.08.11, the contractor shall repeat these test(s) at no extra cost to the purchaser.

Further, in the event of any discrepancy in the test reports i.e. any test report not acceptable due to any design/manufacturing changes (including substitution of components) or due to non-compliance with the requirement stipulated in the Technical Specification or any/all type tests not carried out, same shall be carried out without any additional cost implication to the Purchaser.

The supplier shall intimate the BHEL/POWERGRID the detailed program about the tests atleast two (2) weeks in advance in case of domestic supplies & six (6) weeks in advance in case of foreign supplies.

Further, in case type tests are required to be conducted/repeated and the deputation of Inspector/Purchaser's representative is required, then all the expenses shall be borne by the supplier.

- 9.3 The Purchaser intends to repeat the type tests on Power Transformer and Shunt Reactor except Dynamic short circuit tests on transformers, for which test charges shall be payable as per provision of contract. The price of conducting type tests shall be included in Bid price and break up of these shall be given in the relevant schedule of Bid Proposal Sheets. These Type test charges would be considered in bid evaluation. In case Bidder does not indicate charges for any of the type tests or does not mention the name of any test in the price schedules, it will be presumed that the particular test has been offered free of charge. Further, in case any Bidder indicates that he shall not carry out a particular test, his offer shall be considered incomplete and shall be liable to be rejected. BHEL/POWERGRID reserves the right to witness any or all the type tests. The BHEL/POWERGRID also reserves the right to waive the repeating of type tests partly or fully and in case of waiver, test charges for the same shall not be payable.

The Purchaser shall bear all expenses for deputation of purchaser's representative(s) for witnessing the type tests under this clause except in the case of re-deputation if any, necessitated due to no fault of the purchaser.

For outdoor receptacles, trefoil clamps, diesel engine, alternator, motors, cable

SECTION –III OF TECHNICAL SPECIFICATION

glands, lighting fixtures, ACSR/AAC conductor, IPS aluminum tube and junction boxes, type test reports are not required to be submitted for the makes indicated at Annexure-E /POWERGRID approved list of subvendors. For the new makes(other than those indicated at Annexure-E / POWERGRID approved list of subvendors), type test reports as per relevant standard shall be submitted for POWERGRID's approval.

- 9.4 The Purchaser, his duly authorised representative and/or outside inspection agency acting on behalf of the Purchaser shall have at all reasonable times free access to the Contractor's/sub-vendors premises or Works and shall have the power at all reasonable times to inspect and examine the materials and workmanship of the Works during its manufacture or erection if part of the Works is being manufactured or assembled at other premises or works, the Contractor shall obtain for the Engineer and for his duly authorised representative permission to inspect as if the works were manufactured or assembled on the Contractor's own premises or works. Inspection may be made at any stage of manufacture, despatch or at site at the option of the Purchaser and the equipment if found unsatisfactory due to bad workmanship or quality, material is liable to be rejected.
- 9.5 The supplier shall give the Purchaser /Inspector fifteen (15) days written notice for on-shore and six (6) weeks notice for off-shore material being ready for joint testing including contractor and POWERGRID. Such tests shall be to the Contractor's account except for the expenses of the Inspector. The Purchaser/inspector, unless witnessing of the tests is virtually waived, will attend such tests within fifteen (15) days of the date of which the equipment is notified as being ready for test/inspection, failing which the Contractor may proceed alone with the test which shall be deemed to have been made in the Inspector's presence and he shall forthwith forward to the Inspector duly certified copies of tests in triplicate.
- 9.6 The Purchaser or Inspector shall, within fifteen (15) days from the date of inspection as defined herein give notice in writing to the Contractor, of any objection to any drawings and all or any equipment and workmanship which in his opinion is not in accordance with the Contract. The Contractor shall give due consideration to such objections and shall either make the modifications that may be necessary to meet the said objections or shall confirm in writing to the Purchaser /Inspector giving reasons therein, that no modifications are necessary to comply with the Contract.
- 9.7 When the factory tests have been completed at the Contractor's or Sub-Contractor's works, the Purchaser/inspector shall issue a certificate to this effect within fifteen (15) days after completion of tests but if the tests are not witnessed by the Purchaser /Inspector, the certificate shall be issued within fifteen (15) days of receipt of the Contractor's Test certificate by the Engineer/Inspector. Failure of the Purchaser /Inspector to issue such a certificate shall not prevent the Contractor from proceeding with the Works. The completion of these tests or the issue of the certificate shall not bind the Purchaser to accept the equipment should, it, on further tests after erection, be found not to comply with the Contract. The equipment shall be dispatched to site only after approval of test reports and issuance of CIP by the Purchaser.
- 9.8 In all cases where the Contract provides for tests whether at the premises or at the works of the Contractor or of any Sub-Contractor, the Contractor except where otherwise specified shall provide free of charge such items as labour, materials, electricity, fuel, water, stores, apparatus and instruments as may be reasonably demanded by the Purchaser /Inspector or his authorised representative to carry out effectively such tests of

SECTION –III OF TECHNICAL SPECIFICATION

the equipment in accordance with the Contract and shall give facilities to the Purchaser /Inspector or to his authorised representative to accomplish testing.

9.9 The inspection by Purchaser and issue of Inspection Certificate thereon shall in no way limit the liabilities and responsibilities of the Contractor in respect of the agreed quality assurance programme forming a part of the Contract.

9.10 The Purchaser will have the right of having at his own expenses any other test(s) of reasonable nature carried out at Contractor's premises or at site or in any other place in addition of aforesaid type and routine tests, to satisfy that the material comply with the specification.

9.11 The Purchaser reserves the right for getting any field tests not specified in respective sections of the technical specification conducted on the completely assembled equipment at site. The testing equipments for these tests shall be provided by the Purchaser.

10.0 TESTS

10.1 Pre-commissioning Tests

On completion of erection of the equipment and before charging, each item of the equipment shall be thoroughly cleaned and then inspected jointly by the Purchaser and the Contractor for correctness and completeness of installation and acceptability for charging, leading to initial pre-commissioning tests at Site. The list of pre-commissioning tests to be performed are given in respective chapters and shall be included in the Contractor's quality assurance programme.

10.2 Commissioning Tests

10.2.1 The available instrumentation and control equipment will to be used during such tests and the Purchaser will calibrate, all such measuring equipment and devices as far as practicable.

10.2.2 Any special equipment, tools and tackles required for the successful completion of the Commissioning Tests shall be provided by the Contractor, free of cost.

10.2.3 The specific tests requirement on equipment have been brought out in the respective chapters of the technical specification.

10.3 The Contractor shall be responsible for obtaining statutory clearances from the concerned authorities for commissioning the equipment and the switchyard. However necessary fee shall be reimbursed by POWERGRID on production of requisite documents.

11.0 PACKAGING & PROTECTION

11.1 All the equipments shall be suitably protected, coated, covered or boxed and crated to prevent damage or deterioration during transit, handling and storage at Site till the time of erection. On request of the Purchaser, the Contractor shall also submit packing details/associated drawing for any equipment/material under his scope of supply, to facilitate the Purchaser to repack any equipment/material at a later date, in case the need arises. While packing all the materials, the limitation from the point of view of availability of Railway wagon sizes in India should be taken into account. The Contractor shall be responsible for any loss or damage during transportation, handling and storage due to improper packing. Any demurrage, wharfage and other such charges claimed by the transporters, railways etc. shall be to the account of the Contractor. Purchaser takes no responsibility of the availability of the wagons.

SECTION –III OF TECHNICAL SPECIFICATION

11.2 All coated surfaces shall be protected against abrasion, impact, discolouration and any other damages. All exposed threaded portions shall be suitably protected with either a metallic or a non-metallic protecting device. All ends of all valves and pipings and conduit equipment connections shall be properly sealed with suitable devices to protect them from damage.

12.0 FINISHING OF METAL SURFACES

12.1 All metal surfaces shall be subjected to treatment for anti-corrosion protection. All ferrous surfaces for external use unless otherwise stated elsewhere in the specification or specifically agreed, shall be hot-dip galvanized after fabrication. High tensile steel nuts & bolts and spring washers shall be electro galvanized to service condition 4. All steel conductors including those used for earthing/grounding (above ground level) shall also be galvanized according to IS:2629.

12.2 HOT DIP GALVANISING

12.2.1 The minimum weight of the zinc coating shall be 610 gm/sq.m and minimum average thickness of coating shall be 86 microns for all items having thickness 6mm and above. For items lower than 6mm thickness requirement of coating thickness shall be as per relevant ASTM. For surface which shall be embedded in concrete, the zinc coating shall be 610 gm/sq. m minimum.

12.2.2 The galvanized surfaces shall consist of a continuous and uniform thick coating of zinc, firmly adhering to the surface of steel. The finished surface shall be clean and smooth and shall be free from defects like discoloured patches, bare spots, unevenness of coating, spelter which is loosely attached to the steel globules, spiky deposits, blistered surface, flaking or peeling off, etc. The presence of any of these defects noticed on visual or microscopic inspection shall render the material liable to rejection.

12.2.3 After galvanizing, no drilling or welding shall be performed on the galvanized parts of the equipment excepting that nuts may be threaded after galvanizing. Sodium dichromate treatment shall be provided to avoid formation of white rust after hot dip galvanization.

12.2.4 The galvanized steel shall be subjected to six one minute dips in copper sulphate solution as per IS-2633.

12.2.5 Sharp edges with radii less than 2.5 mm shall be able to withstand four immersions of the Standard Preece test. All other coatings shall withstand six immersions. The following galvanizing tests should essentially be performed as per relevant Indian Standards.

- Coating thickness
- Uniformity of zinc
- Adhesion test
- Mass of zinc coating

12.2.6 Galvanised material must be transported properly to ensure that galvanised surfaces are not damaged during transit. Application of zinc rich paint at site shall not be allowed.

12.3 PAINTING

12.3.1 All sheet steel work shall be degreased, pickled, phosphated in accordance with the IS-6005 "Code of practice for phosphating iron and sheet". All surfaces, which will not be easily accessible after shop assembly, shall beforehand be treated and protected for the

SECTION –III OF TECHNICAL SPECIFICATION

life of the equipment. The surfaces, which are to be finished painted after installation or require corrosion protection until installation, shall be shop painted with at least two coats of primer. Oil, grease, dirt and swaf shall be thoroughly removed by emulsion cleaning. Rust and scale shall be removed by pickling with dilute acid followed by washing with running water, rinsing with slightly alkaline hot water and drying.

- 12.3.2 After phosphating, thorough rinsing shall be carried out with clean water followed by final rinsing with dilute dichromate solution and oven drying. The phosphate coating shall be sealed with application of two coats of ready mixed, stoving type zinc chromate primer. The first coat may be “flash dried” while the second coat shall be stoved.
- 12.3.3 After application of the primer, two coats of finishing synthetic enamel paint shall be applied, each coat followed by stoving. The second finishing coat shall be applied after inspection of first coat of painting.
- 12.3.4 The exterior and interior colour of the paint in case of new substations shall preferably be RAL 7032 for all equipment, marshalling boxes, junction boxes, control cabinets, panels etc. unless specifically mentioned under respective sections of the equipments. Glossy white colour inside the equipments /boards/panels/junction boxes is also acceptable. The exterior colour for panels shall bematching with the existing panels in case of extension of a substation. Each coatof primer and finishing paint shall be of slightly different shade to enable inspection of the painting. A small quantity of finishing paint shall be supplied for minor touching up required at site after installation of the equipments.
- 12.3.5 In case the Bidder proposes to follow his own standard surface finish and protection procedures or any other established painting procedures, like electrostatic painting etc., the procedure shall be submitted alongwith the Bids for Purchaser’s review & approval.
- 12.3.6 The colour scheme as given below shall be followed for Fire Protection and Air Conditioning systems

| S.No. | PIPE LINE | Base colour | Band colour |
|--------------------------------|--|----------------------|-------------|
| Fire Protection System | | | |
| 1 | Hydrant and Emulsifier system pipeline | FIRE RED | - |
| 2 | Emulsifier system detection line – water | FIRE RED | Sea Green |
| 3 | Emulsifier system detection line – Air | FIRE RED | Sky Blue |
| 4 | Pylon support pipes | FIRE RED | |
| Air Conditioning System | | | |
| 5 | Refrigerant gas pipeline – at compressor suction | Canary Yellow | - |
| 6 | Refrigerant gas pipeline – at compressor discharge | Canary Yellow | Red |
| 7 | Refrigerant liquid pipeline | Dark Admiralty Green | - |
| 8 | Chilled water pipeline | Sea Green | - |
| 9 | Condenser water pipeline | Sea Green | Dark Blue |

SECTION –III OF TECHNICAL SPECIFICATION

12.3.7 For aluminium casted surfaces, the surface shall be with smooth finish. Further, in case of aluminium enclosures the surface shall be coated with powder (coating thickness of 60 microns) after surface preparation for painting.

13.0 HANDLING, STORING AND INSTALLATION

- 13.1 In accordance with the specific installation instructions as shown on manufacturer's drawings or as directed by the Purchaser or his representative, the Contractor shall unload, store, erect, install, wire, test and place into commercial use all the equipment included in the contract. Equipment shall be installed in a neat, workmanlike manner so that it is level, plumb, square and properly aligned and oriented. Commercial use of switchyard equipment means completion of all site tests specified and energisation at rated voltage.
- 13.2 Contractor may engage manufacturer's Engineers to supervise the unloading, transportation to site, storing, testing and commissioning of the various equipment being procured by them separately. Contractor shall unload, transport, store, erect, test and commission the equipment as per instructions of the manufacturer's supervisory Engineer(s) and shall extend full cooperation to them.
- 13.3 The contractor shall have to ensure that the hard and flat indoor and outdoor storage areas are in place prior to commencement of delivery of material at site. Contractor shall also ensure availability of proper unloading and material handling equipment like cranes etc. and polyester/nylon ropes of suitable capacity to avoid damage during unloading and handling of material at site. All indoor equipments shall be stored indoors. Outdoor equipment may be stored outdoors but on a hard and flat raised area properly covered with waterproof and dustproof covers to protect them from water seepage and moisture ingress. However, all associated control panels, marshalling boxes operating boxes etc. of outdoor equipments are to be stored indoors only. Storage of equipment on top of another one is not permitted if the wooden packing is used. Material opened for joint inspection shall be repacked properly as per manufacturer's recommendations. During storage of material regular periodic monitoring of important parameters like oil level / leakage, SF6 / Nitrogen pressure etc. shall be ensured by the contractor.
- 13.4 In case of any doubt/misunderstanding as to the correct interpretation of manufacturer's drawings or instructions, necessary clarifications shall be obtained from the Purchaser. Contractor shall be held responsible for any damage to the equipment consequent to not following manufacturer's drawings/instructions correctly.
- 13.5 Where assemblies are supplied in more than one section, Contractor shall make all necessary mechanical and electrical connections between sections including the connection between buses. Contractor shall also do necessary adjustments/alignments necessary for proper operation of circuit breakers, isolators and their operating mechanisms. All components shall be protected against damage during unloading, transportation, storage, installation, testing and commissioning. Any equipment damaged due to negligence or carelessness or otherwise shall be replaced by the Contractor at his own expense.
- 13.6 Supplier shall be responsible for examining all the shipment and notify the Purchaser immediately of any damage, shortage, discrepancy etc. for the purpose of Purchaser's information only. The Contractor shall submit to the Purchaser every

SECTION –III OF TECHNICAL SPECIFICATION

week a report detailing all the receipts during the weeks. However, the Contractor shall be solely responsible for any shortages or damages in transit, handling and/or in storage and erection of the equipment at Site Any demurrage, wharfage and other such charges claimed by the transporters, railways etc. shall be to the account of the Contractor.

- 13.7 The supplier shall be fully responsible for the equipment/material until the same is handed over to the Purchaser in an operating condition after commissioning. Contractor shall be responsible for the maintenance of the equipment/material while in storage as well as after erection until taken over by Purchaser, as well as protection of the same against theft, element of nature, corrosion, damages etc.
- 13.8 Where material / equipment is unloaded by Purchaser before the Contractor arrives at site or even when he is at site, Purchaser by right can hand over the same to Contractor and there upon it will be the responsibility of Contractor to store the material in an orderly and proper manner.
- 13.9 The Contractor shall be responsible for making suitable indoor storage facilities, to store all equipment which requires indoor storage.
- 13.10 The words ‘erection’ and ‘installation’ used in the specification are synonymous.
- 13.11 Exposed live parts shall be placed high enough above ground to meet the requirements of electrical and other statutory safety codes.

13.12 Equipment Bases

A cast iron or welded steel base plate shall be provided for all rotating equipment which is to be installed on a concrete base unless otherwise agreed to by the Purchaser. Each base plate shall support the unit and its drive assembly, shall be of a neat design with pads for anchoring the units, shall have a raised lip all around, and shall have threaded drain connections.

14.0 TOOLS AND TACKLES

The Contractor shall supply with the equipment one complete set of all special tools and tackles for the erection, assembly, dis-assembly and maintenance of the equipment. However, these tools and tackles shall be separately, packed and brought on to Site.

15.0 AUXILIARY SUPPLY

- 15.1 The sub-station auxiliary supply is normally met through a system indicated under section “Electrical & Mechanical Auxiliaries” having the following parameters. The auxiliary power for station supply, including the equipment drive, cooling system of any equipment, air-conditioning, lighting etc shall be designed for the specified Parameters as under. The DC supply for the instrumentation and PLCC system shall also conform the parameters as indicated in the following.

| Normal Voltage | Variation in Voltage | Frequency in HZ | Phase/Wire | Neutral connection |
|----------------|----------------------|-----------------|------------|------------------------|
| 415V | ± 10% | 50 ± 5% | 3/4 Wire | Solidly Earthed. |
| 240V | ± 10% | 50 ± 5% | 1/2 Wire | Solidly Earthed. |
| 220V | 190V to 240V | DC | - | Isolated 2 wire System |

SECTION –III OF TECHNICAL SPECIFICATION

| | | | | |
|-----|---|----|---|---------------------------|
| 48V | – | DC | – | 2 wire system (+) earthed |
|-----|---|----|---|---------------------------|

Combined variation of voltage and frequency shall be limited to $\pm 10\%$.

16.0 SUPPORT STRUCTURE (If in the scope of supplier)

16.1 The equipment support structures shall be suitable for equipment connections at the first level i.e 14.0 meter, 8.0 meter and 5.9 meter from plinth level for 765 kV,420 kV and 245 kV substations respectively. All equipment support structures shall be supplied alongwith brackets, angles, stools etc. for attaching the operating mechanism, control cabinets & marshalling box (wherever applicable) etc.

16.2 Support structure shall meet the following mandatory requirements:

16.2.1 The minimum vertical distance from the bottom of the lowest porcelain part of the bushing, porcelain enclosures or supporting insulators to the bottom of the equipment base, where it rests on the foundation pad shall be 2.55 metres.

17.0 CLAMPS AND CONNECTORS INCLUDING TERMINAL CONNECTORS

17.1 All power clamps and connectors shall conform to IS:5561 & NEMA CC1 and shall be made of materials listed below :

- | | | |
|----|--|---|
| a) | For connecting ACSR conductors | Aluminum alloy casting, conforming to designation A6 of IS:617 and all test shall conform to IS:617 |
| b) | For connecting equipment terminals made of copper with ACSR conductors | Bimetallic connectors made from aluminum alloy casting, conforming to designation A6 of IS:617 with 2mm thick bimetallic liner and all test shall conform to IS:617 |
| c) | For connecting G.I | Galvanised mild steel shield wire |
| d) | i) Bolts, nuts & Plain, washers | i) Electro-galvanised for sizes below M12, for others hot dip galvanised. |
| | ii) Spring washers items 'a' to 'c' | ii) Electro-galvanised mild for steel suitable for atleast service condition-3 as per IS:1573 |

17.2 Necessary clamps and connectors shall be supplied for all equipment and connections. The requirement regarding external corona and RIV as specified for any equipment shall include its terminal fittings. If corona rings are required to meet these requirements they shall be considered as part of that equipment and included in the scope of work.

17.3 Where copper to aluminum connections are required, bi-metallic clamps shall be used, which shall be properly designed to ensure that any deterioration of the connection is kept to a minimum and restricted to parts which are not current carrying or subjected to stress.

17.4 Low voltage connectors, grounding connectors and accessories for grounding allequipment as specified in each particular case, are also included in the scope of Work.

17.5 No current carrying part of any clamp shall be less than 10 mm thick. All ferrous

SECTION –III OF TECHNICAL SPECIFICATION

parts shall be hot dip galvanised. Copper alloy liner of minimum 2 mm thickness shall be cast integral with aluminum body or 2 mm thick bi-metallic strips shall be provided for Bi-metallic clamps.

- 17.6 All casting shall be free from blow holes, surface blisters, cracks and cavities. All sharp edges and corners shall be blurred and rounded off.
- 17.7 Flexible connectors, braids or laminated straps made for the terminal clamps for bus posts shall be suitable for both expansion or through (fixed/sliding) type connection of 4" IPS AL. tube as required. In both the cases the clamp height (top of the mounting pad to centre line of the tube) should be same.
- 17.8 Clamp shall be designed to carry the same current as the conductor and the temperature rise shall be equal or less than that of the conductor at the specified ambient temperature. The rated current for which the clamp/connector is designed with respect to the specified reference ambient temperature, shall also be indelibly marked on each component of the clamp/connector, except on the hardware.
- 17.9 All current carrying parts shall be designed and manufactured to have minimum contact resistance.
- 17.10 Clamps and connectors shall be designed to be corona controlled.

17.11 Tests

- 17.11.1 Clamps and connectors should be type tested as per IS:5561 and shall also be subjected to routine tests as per IS:5561. Following type test reports shall be submitted for approval as per clause 9.2 above except for sl. no.(ii) & (iii) for which type test once conducted shall be applicable (i.e. the requirement of test conducted within last ten years shall not be applicable).
 - i) Temperature rise test (maximum temperature rise allowed is 35°C over 50°C ambient)
 - ii) Short time current test
 - iii) Corona (dry) and RIV (dry) test (for 220 KV and above voltage level clamps)
 - iv) Resistance test and tensile test

18.0 CONTROL CABINETS, JUNCTION BOXES, TERMINAL BOXES & MARSHALLING BOXES FOR OUTDOOR EQUIPMENT

- 18.1 All types of boxes, cabinets etc. shall generally conform to & be tested in accordance with IS-5039/IS-8623, IEC-60439, as applicable, and the clauses given below:
- 18.2 Control cabinets, junction boxes, Marshalling boxes & terminal boxes shall be made of sheet steel or aluminum enclosure and shall be dust, water and vermin proof. Sheet steel used shall be atleast 2.0 mm thick cold rolled or 2.5 mm hot rolled or alternately 1.6 mm thick stainless steel can also be used. The box shall be properly braced to prevent wobbling. There shall be sufficient reinforcement to provide level surfaces, resistance to vibrations and rigidity during transportation and installation. In case of aluminum enclosed box the thickness of aluminum shall be such that it provides adequate rigidity and long life as comparable with sheet steel of specified thickness.
- 18.3 A canopy and sealing arrangements for operating rods shall be provided inmarshalling boxes / Control cabinets to prevent ingress of rain water.
- 18.4 Cabinet/boxes shall be provided with double hinged doors with padlocking

SECTION –III OF TECHNICAL SPECIFICATION

- arrangements. The distance between two hinges shall be adequate to ensure uniform sealing pressure against atmosphere. The quality of the gasket shall be such that it does not get damaged/cracked during the operation of the equipment.
- 18.5 All doors, removable covers and plates shall be gasketed all around with suitably profiled EPDM/Neoprene gaskets. The gasket shall be tested in accordance with approved quality plan, IS:11149 and IS:3400. Ventilating Louvers, if provided, shall have screen and filters. The screen shall be fine wire mesh made of brass.
- 18.6 All boxes/cabinets shall be designed for the entry of cables from bottom by means of weather proof and dust-proof connections. Boxes and cabinets shall be designed with generous clearances to avoid interference between the wiring entering from below and any terminal blocks or accessories mounted within the box or cabinet.
Suitable cable gland plate above the base of the marshalling kiosk/box shall be provided for this purpose along with the proper blanking plates. Necessary number of cable glands shall be supplied and fitted on this gland plate. Gland plate shall have provision for some future glands to be provided later, if required. The Nickel plated glands shall be dust proof, screw on & double compression type and made of brass. The gland shall have provision for securing armour of the cable separately and shall be provided with earthing tag. The glands shall conform to BS:6121.
- 18.7 A 240V, single phase, 50 Hz, 15 amp AC plug and socket shall be provided in the cabinet with ON-OFF switch for connection of hand lamps. Plug and socket shall be of industrial grade.
- 18.8 For illumination, a fluorescent tube or CFL of approximately 9 to 15 watts shall be provided. The switching of the fittings shall be controlled by the door switch. .
For junction boxes of smaller sizes such as lighting junction box, manual operated earth switch mechanism box etc., plug socket, heater and illumination is not required to be provided.
- 18.9 All control switches shall be of MCB/rotary switch type and Toggle/piano switches shall not be accepted.
- 18.10 Positive earthing of the cabinet shall be ensured by providing two separate earthing pads. The earth wire shall be terminated on to the earthing pad and secured by the use of self etching washer. Earthing of hinged door shall be done by using a separate earth wire.
- 18.11 The bay marshalling kiosks shall be provided with danger plate and a diagram showing the numbering/connection/feruling by pasting the same on the inside of the door.
- 18.12 a) The following routine tests alongwith the routine tests as per IS:5039 shall also be conducted:
i) Check for wiring
ii) Visual and dimension check
b) The enclosure of bay marshalling kiosk, junction box, terminal box shall conform to IP-55 as per IS:13947 including application of, 2.5 KV rms for 1 (one) minute, insulation resistance and functional test after IP-55 test.
- 19.0 Deleted.
- 20.0 **TERMINAL BLOCKS AND WIRING**
- 20.1 Control and instrument leads from the switchboards or from other equipment will be brought to terminal boxes or control cabinets in conduits. All interphase and external connections to equipment or to control cubicles will be made through terminal blocks.

SECTION –III OF TECHNICAL SPECIFICATION

- 20.2 Terminal blocks shall be 650V grade and have continuous rating to carry the maximum expected current on the terminals and non breakable type. These shall be of moulded piece, complete with insulated barriers, stud type terminals, washers, nuts and lock nuts. Screw clamp, overall insulated, insertion type, rail mounted terminals can be used in place of stud type terminals. But preferably the terminal blocks shall be non-disconnecting stud type of Elmex or Phoenix or Wago or equivalent make.
- 20.3 Terminal blocks for current transformer and voltage transformer secondary leads shall be provided with test links and isolating facilities. The current transformer secondary leads shall also be provided with short circuiting and earthing facilities.
- 20.4 The terminal shall be such that maximum contact area is achieved when a cable is terminated. The terminal shall have a locking characteristic to prevent cable from escaping from the terminal clamp unless it is done intentionally.
- 20.5 The conducting part in contact with cable shall preferably be tinned or silver plated however Nickel plated copper or zinc plated steel shall also be acceptable.
- 20.6 The terminal blocks shall be of extensible design.
- 20.7 The terminal blocks shall have locking arrangement to prevent its escape from the mounting rails.
- 20.8 The terminal blocks shall be fully enclosed with removable covers of transparent, non-deteriorating type plastic material. Insulating barriers shall be provided between the terminal blocks. These barriers shall not hinder the operator from carrying out the wiring without removing the barriers.
- 20.9 Unless otherwise specified terminal blocks shall be suitable for connecting the following conductors on each side.
- | | | |
|----|------------------------------------|---|
| a) | All circuits except CT/PT circuits | Minimum of two of 2.5 sq mm copper flexible. |
| b) | All CT/PT circuits | Minimum of 4 nos. of 2.5 sq mm copper flexible. |
- 20.10 The arrangements shall be in such a manner so that it is possible to safely connect or disconnect terminals on live circuits and replace fuse links when the cabinet is live.
- 20.11 Atleast 20 % spare terminals shall be provided on each panel/cubicle/box and these spare terminals shall be uniformly distributed on all terminals rows.
- 20.12 There shall be a minimum clearance of 250 mm between the First/bottom row of terminal block and the associated cable gland plate for outdoor ground mounted marshalling box and the clearance between two rows of terminal blocks shall be a minimum of 150 mm.
- 20.13 The supplier shall furnish all wire, conduits and terminals for the necessary interphase electrical connections (where applicable) as well as between phases and common terminal boxes or control cabinets. For equipments rated for 400 kV and above the wiring required in these items shall be run in metallic ducts or shielded cables in order to avoid surge overvoltages either transferred through the equipment or due to transients induced from the EHV circuits.
- 20.14 All input and output terminals of each control cubicle shall be tested for surge withstand capability in accordance with the relevant IEC Publications, in both longitudinal and transverse modes. The Contractor shall also provide all necessary filtering, surge protection, interface relays and any other measures necessary to achieve an impulse withstand level at the cable interfaces of the equipment.

SECTION –III OF TECHNICAL SPECIFICATION

21.0 LAMPS & SOCKETS

21.1 Sockets

All sockets (convenience outlets) shall be suitable to accept both 5 Amp & 15 Amp pin round Standard Indian plugs. They shall be switched sockets with shutters.

21.2 Hand Lamp:

A 240 Volts, single Phase, 50 Hz AC plug point shall be provided in the interior of each cubicle with ON-OFF Switch for connection of hand lamps.

21.3 Switches and Fuses:

- 21.3.1 Each panel shall be provided with necessary arrangements for receiving, distributing, isolating and fusing of DC and AC supplies for various control, signalling, lighting and space heater circuits. The incoming and sub-circuits shall be separately provided with miniature circuit breaker / switchfuse units. Selection of the main and Sub-circuit fuse ratings shall be such as to ensure selective clearance of sub-circuit faults. Potential circuits for relaying and metering shall be protected by HRC fuses.
- 21.3.2 All fuses shall be of HRC cartridge type conforming to IS:9228 mounted on plug-in type fuse bases. Miniature circuit breakers with thermal protection and alarm contacts will also be accepted. All accessible live connection to fuse bases shall be adequately shrouded. Fuses shall have operation indicators for indicating blown fuse condition. Fuse carrier base shall have imprints of the fuse rating and voltage.

22.0 Bushings, Hollow Column Insulators, Support Insulators:

- 22.1 Bushings shall be manufactured and tested in accordance with IS:2099 & IEC- 60137 while hollow column insulators shall be manufactured and tested in accordance with IEC-62155/IS:5621. The support insulators shall be manufactured and tested as per IS:2544/IEC-60168 and IEC-60273. The insulators shall also conform to IEC-60815 as applicable. The bidder may also offer composite hollow insulators, conforming to IEC-61462.
- 22.2 Support insulators, bushings and hollow column insulators shall be manufactured from high quality porcelain Porcelain used shall be homogeneous, free from laminations, cavities and other flaws or imperfections that might affect the mechanical or dielectric quality and shall be thoroughly vitrified tough and impervious to moisture.
- 22.3 Glazing of the porcelain shall be uniform brown in colour, free from blisters, burrs and similar other defects.
- 22.4 Support insulators/bushings/hollow column insulators shall be designed to have ample insulation, mechanical strength and rigidity for the conditions under which they will be used.
- 22.5 When operating at normal rated voltage there shall be no electric discharge between the conductors and bushing which would cause corrosion or injury to conductors, insulators or supports by the formation of substances produced by chemical action. No radio interference shall be caused by the insulators/bushings when operating at the normal rated voltage.
- 22.6 Bushing porcelain shall be robust and capable of withstanding the internal pressures likely to occur in service. The design and location of clamps and the shape and the strength of the porcelain flange securing the bushing to the tank shall be such that there is no risk of fracture. All portions of the assembled porcelain enclosures and supports other than gaskets, which may in any way be

SECTION –III OF TECHNICAL SPECIFICATION

exposed to the atmosphere shall be composed of completely non hygroscopic material such as metal or glazed porcelain.

- 22.7 All iron parts shall be hot dip galvanised and all joints shall be air tight. Surface of joints shall be trued up porcelain parts by grinding and metal parts by machining. Insulator/bushing design shall be such as to ensure a uniform compressive pressure on the joints.

22.8 Tests

In bushing, hollow column insulators and support insulators shall conform to type tests and shall be subjected to routine tests in accordance with IS: 2099 & IS:2544 & IS : 5621.

23.0 MOTORS

Motors shall be “Squirrel Cage” three phase induction motors of sufficient size capable of satisfactory operation for the application and duty as required for the driven equipment and shall be subjected to routine tests as per applicable standards. The motors shall be of approved make.

23.1 Enclosures

- a) Motors to be installed outdoor without enclosure shall have hose proof enclosure equivalent to IP-55 as per IS: 4691. For motors to be installed indoor i.e. inside a box, the motor enclosure, shall be dust proof equivalent to IP-44 as per IS: 4691.
- b) Two independent earthing points shall be provided on opposite sides of the motor for bolted connection of earthing conductor.
- c) Motors shall have drain plugs so located that they will drain water resulting from condensation or other causes from all pockets in the motor casing.
- d) Motors weighing more than 25 Kg. shall be provided with eyebolts, lugs or other means to facilitate lifting.

23.2 Operational Features

- a) Continuous motor rating (name plate rating) shall be at least ten (10) percent above the maximum load demand of the driven equipment at design duty point and the motor shall not be over loaded at any operating point of driven equipment that will rise in service.
- b) Motor shall be capable at giving rated output without reduction in the expected life span when operated continuously in the system having the particulars as given in Clause 15.0 of this Section.

23.3 Starting Requirements:

- a) All induction motors shall be suitable for full voltage direct-on-line starting. These shall be capable of starting and accelerating to the rated speed alongwith the driven equipment without exceeding the acceptable winding temperature even when the supply voltage drops down to 80% of the rated voltage.
- b) Motors shall be capable of withstanding the electrodynamic stresses and heating imposed if it is started at a voltage of 110% of the rated value.
- c) The locked rotor current shall not exceed six (6) times the rated full load current for all motors, subject to tolerance as given in IS:325.
- d) Motors when started with the driven equipment imposing full starting torque

SECTION –III OF TECHNICAL SPECIFICATION

under the supply voltage conditions specified under Clause 15.0 shall be capable of withstanding atleast two successive starts from cold condition at room temperature and one start from hot condition without injurious heating of winding. The motors shall also be suitable for three equally spread starts per hour under the above referred supply condition.

- e) The locked rotor withstand time under hot condition at 110% of rated voltage shall be more than starting time with the driven equipment of minimum permissible voltage by at least two seconds or 15% of the accelerating time whichever is greater. In case it is not possible to meet the above requirement, the Bidder shall offer centrifugal type speed switch mounted on the motor shaft which shall remain closed for speed lower than 20% and open for speeds above 20% of the rated speed. The speed switch shall be capable of withstanding 120% of the rated speed in either direction of rotation.

23.4 Running Requirements:

- a) The maximum permissible temperature rise over the ambient temperature of 50 degree C shall be within the limits specified in IS:325 (for 3 - phase induction motors) after adjustment due to increased ambient temperature specified.
- b) The double amplitude of motor vibration shall be within the limits specified in IS: 4729. Vibration shall also be within the limits specified by the relevant standard for the driven equipment when measured at the motor bearings.
- c) All the induction motors shall be capable of running at 80% of rated voltage for a period of 5 minutes with rated load commencing from hot condition.

23.5 TESTING AND COMMISSIONING

An indicative list of tests is given below. Contractor shall perform any additional test based on specialities of the items as per the field Q.P./Instructions of the equipment Contractor or Purchaser without any extra cost to the Purchaser. The Contractor shall arrange all instruments required for conducting these tests alongwith calibration certificates and shall furnish the list of instruments to the Purchaser for approval.

- (a) Insulation resistance.
- (b) Phase sequence and proper direction of rotation.
- (c) Any motor operating incorrectly shall be checked to determine the cause and the conditions corrected.

SECTION –III OF TECHNICAL SPECIFICATION

ANNEXURE-A

CORONA AND RADIO INTERFERENCE VOLTAGE (RIV) TEST

1. General

Unless otherwise stipulated, all equipment together with its associated connectors, where applicable, shall be tested for external corona (for 400kV & above) both by observing the voltage level for the extinction of visible corona under falling power frequency voltage and by measurement of radio interference voltage (RIV) for 132kV and above.

2. Test Levels:

The test voltage levels for measurement of external RIV and for corona extinction voltage are listed under the relevant clauses of the specification.

3. Test Methods for RIV:

- 3.1 RIV tests shall be made according to measuring circuit as per International Special-Committee on Radio Interference (CISPR) Publication 16-1(1993) Part -1. The measuring circuit shall preferably be tuned to frequency with 10% of 0.5 Mhz but other frequencies in the range of 0.5 MHz to 2 MHz may be used, the measuring frequency being recorded. The results shall be in microvolts.
- 3.2 Alternatively, RIV tests shall be in accordance with NEMA standard Publication No. 107-1964, except otherwise noted herein.
- 3.3 In measurement of, RIV, temporary additional external corona shielding may be provided. In measurements of RIV only standard fittings of identical type supplied with the equipment and a simulation of the connections as used in the actual installation will be permitted in the vicinity within 3.5 meters of terminals.
- 3.4 Ambient noise shall be measured before and after each series of tests to ensure that there is no variation in ambient noise level. If variation is present, the lowest ambient noise level will form basis for the measurements. RIV levels shall be measured at increasing and decreasing voltages of 85%, 100%, and 110% of the specified RIV test voltage for all equipment unless otherwise specified. The specified RIV test voltage for 765kV, 400 kV, 220 KV is listed in the detailed specification together with maximum permissible RIV level in microvolts.
- 3.5 The metering instruments shall be as per CISPR recommendation or equivalent device so long as it has been used by other testing authorities.
- 3.6 The RIV measurement may be made with a noise meter. A calibration procedure of the frequency to which noise meter shall be tuned shall establish the ratio of voltage at the high voltage terminal to voltage read by noise meter.

4. Test Methods for Visible Corona

The purpose of this test is to determine the corona extinction voltage of apparatus, connectors etc. The test shall be carried out in the same manner as RIV test described above with the exception that RIV measurements are not required during test and a search technique shall be used near the onset and extinction voltage, when the test voltage is raised and lowered to determine their precise values. The test voltage shall be raised to 110% of specified corona extinction voltage and maintained there for five minutes. In case corona inception does not take place at 110%, test shall be stopped, otherwise test shall be continued and the voltage will then be decreased slowly until all visible corona disappears. The procedure

SECTION –III OF TECHNICAL SPECIFICATION

shall be repeated at least 4 times with corona inception and extinction voltage recorded each time. The corona extinction voltage for purposes of determining compliance with the specification shall be the lowest of the four values at which visible corona (negative or positive polarity) disappears. Photographs with laboratory in complete darkness shall be taken under test conditions, at all voltage steps i.e. 85%, 100%, and 110%. Additional photographs shall be taken at corona inception and extinction voltages. At least two views shall be photographed in each case using Panchromatic film with an ASA daylight rating of 400 with an exposure of two minutes at a lens aperture of f/5.6 or equivalent. The photographic process shall be such that prints are available for inspection and comparison with conditions as determined from direct observation. Photographs shall be taken from above and below the level of connector so as to show corona on bushing, insulators and all parts of energised connectors. The photographs shall be framed such that test object essentially, fills the frame with no cut-off.

For recording purpose, modern devices utilizing UV recording methods such as image intensifier may also be used.

- 4.1 The test shall be recorded on each photograph. Additional photograph shall be taken from each camera position with lights on to show the relative position of test object to facilitate precise corona location from the photographic evidence.
- 4.2 In addition to photographs of the test object preferably four photographs shall be taken of the complete test assembly showing relative positions of all the test equipment and test objects. These four photographs shall be taken from four points equally spaced around the test arrangement to show its features from all sides. Drawings of the laboratory and test set up locations shall be provided to indicate camera positions and angles. The precise location of camera shall be approved by Purchaser's inspector, after determining the best camera locations by trial energisation of test object at a voltage which results in corona.
- 4.3 The test to determine the visible corona extinction voltage need not be carried out simultaneously with test to determine RIV levels.
- 4.4 However, both test shall be carried out with the same test set up and as little time duration between tests as possible. No modification on treatment of the sample between tests will be allowed. Simultaneous RIV and visible corona extinction voltage testing may be permitted at the discretion of Purchaser's inspector if, in his opinion, it will not prejudice other test.

5. **Test Records:**

In addition to the information previously mentioned and the requirements specified as per CISPR or NEMA 107-1964 the following data shall be included in test report:

- a) Background noise before and after test.
- b) Detailed procedure of application of test voltage.
- c) Measurements of RIV levels expressed in micro volts at each level.
- d) Results and observations with regard to location and type of interference sources detected at each step.
- e) Test voltage shall be recorded when measured RIV passes through 100microvolts in each direction.
- f) Onset and extinction of visual corona for each of the four tests required shall be recorded.

SECTION –III OF TECHNICAL SPECIFICATION

ANNEXURE-B

SEISMIC WITHSTAND TEST PROCEDURE

The seismic withstanding test on the complete equipment (for 132kV and above) shall be carried out along with supporting structure.

The Bidder shall arrange to transport the structure from his Contractor's premises/POWERGRID sites for the purpose of seismic withstand test only. The seismic level specified shall be applied at the base of the structure. The accelerometers shall be provided at the Terminal Pad of the equipment and any other point as agreed by the Purchaser. The seismic test shall be carried out in all possible combinations of the equipment. The seismic test procedure shall be furnished for approval of the POWERGRID.

SECTION -4
TECHNICAL DATA REQUIREMENTS

Control and Relay panels

- 1 Name & country of Manufacture of panels
- 2 Manufacturer's type & and designation
- 3 Type of construction (Simplex / Duplex)
- 4 Thickness of sheet steel
 - (I) Front
 - (ii) Back
 - (iii) Sides
- 5 Degree of Protection
- 6 Name of the manufacturer of relays
- 7 DC Voltage of the relays
- 8 Make and model of static (0.2 accuracy class type) energy meters
- 9 Confirm whether offered C&R panel manufacturer and protective relays have tested commissioned and they are in successful operation for at least two years in 400kV System

TRANSMISSION LINE PROTECTION

Numerical Distance protection Scheme / *CURRENT Line Differential protection.*

- 1 Name & country of Manufacture
- 2 Manufacturer type & designation
- 3 Switched or Non switched type (is it with separate measurement for single / three phase faults)
- 4 Setting range of offset feature
- 5 Whether relay is having self monitoring feature

SECTION -4
TECHNICAL DATA REQUIREMENTS

- 6 Whether relay is compatible for PLCC equipment and can be used for permissive/ under reach/over reach/ Blocking scheme
- 7 Suitable for single & three phase trip
- 8 Type of shaped characteristic
- 9 No. of tripping contacts with making capacity of 30 amps for 0.2 seconds
- 10 In case 16 contacts as per above clause are not available with the distance relay offered, type of tripping relay being offered
- 11 Maximum operating time for at 50% of the reach setting of 2 ohms and 10/20 ohms (with CVT) including all trip relays, if any (Bidder is required to enclose isochronic curve with CVT on Line)
 - a) at SIR = 4
 - b) at SIR=15 (3 Phase faults)
 - c) at SIR =15 (other faults)
- 12 IDMT earth fault relay meeting Normal Inverse characteristics as per IEC 60253 is being offered as built in feature for 400/220 kV Lines
- 13 If no type of IDMT relay being offered
- 14 Built in feature offered with the relay (Yes/No)
 - a) Disturbance Recorder
 - b) Fault Locator
 - c) Over voltage (one stage only)
 - d) Auto reclose relay along with dead line charging and check synchronising

STATIC Distance Protection Scheme

- 1 Name & country of Manufacture
- 2 Manufacturer type & designation
- 3 Switched or Non switched type (is it with separate measurement for single / three phase faults)
- 4 Setting range of offset feature
- 5 Whether relay is having self monitoring feature

SECTION -4
TECHNICAL DATA REQUIREMENTS

- 6 Whether relay is compatible for PLCC equipment and can be used for permissive/ under reach/over reach/ Blocking scheme
- 7 Suitable for single & three phase trip
- 8 Type of shaped characteristic
- 9 No. of tripping contacts with making capacity of 30 amps for 0.2 seconds
- 10 In case 16 contacts as per above clause are not available with the distance relay offered, type of tripping relay being offered
- 11 Maximum operating time for at 50% of the reach setting of 2 ohms and 10/20 ohms (with CVT) including all trip relays, if any (Bidder is required to enclose isochronic curve with CVT on Line)
 - a) at SIR = 4
 - b) at SIR=15 (3 Phase faults)
 - c) at SIR =15 (other faults)
- 12 IDMT earth fault relay meeting Normal Inverse characteristics as per IEC 60253 is being offered as built in feature for 400/220 kV Lines
- 13 If no type of IDMT relay being offered
- 14 Built in feature offered with the relay (Yes/No)
 - a) Disturbance Recorder
 - b) Fault Locator
 - c) Over voltage (one stage only)
 - d) Auto reclose relay along with check synchronising relay (for 132 kV Lines)

Directional O/C and E/F Relay

- 1 Name & country of Manufacture
- 2 Manufacturer type & designation
- 3 Three over current and one E/F element(s) are whether independent or composite units
- 4 Type of relay Electromechanical/ static/ Numerical

SECTION -4
TECHNICAL DATA REQUIREMENTS

- 5 Whether characteristics will confirm to IEC255-3
- 6 Directional sensitivity
- 7 Overcurrent unit setting range
 - a) Inverse time
 - b) High set inst. Unit
- 8 Earth fault unit setting range
 - a) Inverse time
 - b) High set inst. Unit
- 9 VT fuse failure relay/ feature included for Alarm

Line Over voltage Protection relay

- 1 Name & country of Manufacture
- 2 Manufacturer type & designation
- 3 Type of Relay (Electromechanical/ Static Numerical)
- 4 Operating indicator provided
- 5 Operating time
- 6 Resetting time
- 7 Whether monitors all three phases ?
- 8 Built in feature of Main 1/Main 2 distance relay is offered. If so which stage is offered as built in

Distance to fault locator

- 1 Name & country of Manufacture
- 2 Manufacturer type & designation
- 3 Built in feature of Main 1/Main 2 distance relay is offered

SECTION -4
TECHNICAL DATA REQUIREMENTS

- 4 Maximum registering time
- 5 Whether direct display unit provided
- 6 Whether both phase to phase fault & phase to earth fault measuring units included
- 7 Whether " On - Line" type
- 8 Accuracy for typical conditions defined under technical specifications

Disturbance Recorder

a. Acquisition unit

- 1 Name & country of Manufacture
- 2 Manufacturer's type & and designation
- 3 No. of Analogue Channels
- 4 No. of Digital recording Channels
- 5 Built in feature of Main 1 / Main 2 distance relay offered
- 6 Pre Fault memory (milli seconds)
- 7 Post Fault memory (seconds)
- 8 Total storage memory in seconds
- 9 Sampling Frequency
- 10 Resolution of event channels (msec)
- 11 Time display present?
- 12 Data output in COMTRADE is available

b. Evaluation Unit

- 1 Name & country of Manufacture
- 2 Manufacturer's type & and designation

SECTION -4
TECHNICAL DATA REQUIREMENTS

- 3 No. of acquisition unit that can be connected to one evaluation unit
- 4 Technical paramters of evaluation unit
 - a. Processor & Speed
 - b. RAM & Hard Disk Capacity
 - c. Additional facilities
 - d. Details of Printer
- 5 Details of Power supply arrangement for acquisition unit (including printer)

Auto Reclose Relay

- 1 Name & country of Manufacture
- 2 Manufacturer type & designation
- 3 Electromechanical / Static / Numerical
- 4 Auto Reclose relay along with dead line charging and check synchronising relay offered as part of distance relay
- 5 Suitable for single & three phase ?
- 6 Single phase dead time setting ranges
- 7 Three phase dead time range earth faults
- 8 Reclaim time seting range

Auto Reclose Relay (FOR NEW SUBSTATION ONLY)

- 1 Name & country of Manufacture
- 2 Manufacturer type & designation
- 3 Electromechanical / Static / Numerical
- 4 Auto Reclose relay along with dead line charging and check synchronising relay offered as part of distance relay
- 5 Suitable for single & three phase ?

SECTION -4
TECHNICAL DATA REQUIREMENTS

- 6 Single phase dead time setting ranges
- 7 Three phase dead time range earth faults
- 8 Reclaim time setting range

TRANSFORMER PROTECTION

Differential relay

- 1 Name & country of Manufacture
- 2 Manufacturer type & designation
- 3 Second harmonic restraint feature provided ?
- 4 Whether three instantaneous units provided
- 5 Operating current setting range
- 6 Bias setting range
- 7 Operating time at 5x setting current
- 8 Resetting time
- 9 How ratio / phase angle corrections are being done (inter posing transformer / internal feature in the relay)

Restricted Earth Fault Relay

- 1 Name and country of Manufacturer
- 2 Manufacturer type and designation
- 3 Operating time at 2 x setting

Overfluxing relays

- 1 Name & country of Manufacture
- 2 Manufacturer type & designation

SECTION -4
TECHNICAL DATA REQUIREMENTS

- 3 Whether inverse time operating characteristics provided ?
- 4 Maximum operating time
- 5 Accuracy operating time
- 6 Resetting time

Directional O/C and E/F Relay

- 1 Name & country of Manufacture
- 2 Manufacturer type & designation
- 3 Whether characteristics will confirm to IEC255-3
- 4 Directional sensitivity
- 5 Overcurrent unit setting range
 - a) Inverse time
 - b) High set inst. Unit
- 6 Earth fault unit setting range
 - a) Inverse time
 - b) High set inst. Unit

REACTOR PROTECTION

Differential relay

- 1 Name & country of Manufacture
- 2 Manufacturer type & designation
- 3 Second harmonic restraint feature provided ?
- 4 Whether three instantaneous units provided
- 5 Operating current setting range

SECTION -4
TECHNICAL DATA REQUIREMENTS

- 6 Bias setting range
- 7 Operating time at 5x setting current
- 8 Resetting time
- 9 How ratio / phase angle corrections are being done (inter posing transformer / internal feature in the relay)

Restricted Earth Fault Relay

- 1 Name and country of Manufacturer
- 2 Manufacturer type and designation
- 3 Operating time at 2 x setting

Back up Impedance Protection Relay

- 1 Name & country of Manufacture
- 2 Manufacturer type & designation
- 3 Whether characteristics will confirm to IEC255-3
- 4 Directional sensitivity
- 5 Overcurrent unit setting range
 - a) Inverse time
 - b) High set inst. Unit
- 6 Earth fault unit setting range
 - a) Inverse time
 - b) High set inst. Unit

SECTION -4
TECHNICAL DATA REQUIREMENTS

GENERAL PROTECTION / MONITORING EQUIPMENT

Trip circuit supervision relay

- 1 Name & country of Manufacture
- 2 Manufacturer type & designation
- 3 Whether preclosing and post closing supervision provided ?
- 4 Time delay

High Speed Trip Relays

- 1 Name & country of Manufacture
- 2 Manufacturer type & designation
- 3 Contacts ratings
 - a) Make & carry continuously
 - b) Make & carry for 0.5 sec
 - c) Break
 - i. Resistive load
 - ii. Inductive load (With L/R = 40 msec)
- 4 Operating time at rated voltage (maximum)
- 5 Resetting time
- 6 Whether supervisory relays included

SECTION -4
TECHNICAL DATA REQUIREMENTS

Local Breaker Back - up protection

- 1 Name & country of Manufacture
- 2 Manufacturer type & designation
- 3 Operating time
- 4 Resetting time
- 5 Setting range
 - (I) Current
 - (ii) Time

Bus bar Protection (APPLICABLE FOR NEW STATION ONLY)

- 1 Name & country of Manufacture
- 2 Manufacturer type & designation
- 3 Type of relay
- 4 Principle of operation
- 5 Operating time
- 6 Resetting time
- 7 Setting ranges
 - (I) Current
 - (ii) Time
- 8 Whether it will cause tripping for the differential current below the load current of heavily loaded feeder (Bidder shall submit application check for the same)