

**TELANGANA STATE POWER GENERATION
CO. LTD**

4X270 MW BHADRADRI TPS

TECHNICAL SPECIFICATION
FOR
**AUXILIARY STEAM PRESSURE REDUCING
AND DESUPERHEATING STATION
ALONGWITH ACCESSORIES**

VOLUME - II B & III

SPECIFICATION No: **PE-TS -411-142-N101 (REV 00)**



BHARAT HEAVY ELECTRICALS LIMITED
POWER SECTOR
PROJECT ENGINEERING MANAGEMENT
PPEI, NOIDA, INDIA

**TELANGANA STATE POWER GENERATION
CO. LTD**

4X270 MW BHADRADRI TPS

TECHNICAL SPECIFICATION
FOR
**AUXILIARY STEAM PRESSURE REDUCING
AND DESUPERHEATING STATION
ALONGWITH ACCESSORIES**

VOLUME – II B

SPECIFICATION No: **PE-TS -411-142-N101 (REV 00)**



BHARAT HEAVY ELECTRICALS LIMITED
POWER SECTOR
PROJECT ENGINEERING MANAGEMENT
PPEI, NOIDA, INDIA



TITLE

PREAMBLE

SPECIFICATION NO **PE-SS-999-100-Q-001**

VOLUME **II B**

SECTION PREAMBLE

REV NO. **0** | DATE 05.02.2008

SHEET 1 OF 1

1.0 Volume – II B :

This volume is sub- divided into following sections: -

Section – A : This section outlines the scope of enquiry

Section – B : This section provides : “ Project Information”.

Section- C : This section indicates tech. Requirements specific to the contract, not covered in Section – D.

Section – D : This section comprises of tech. Specifications of equipments complete with data sheet A,B&C.

Data Sheet – A specifics data and other requirements pertaining to the equipment.

Data sheet – B specifics data to be filled by the bidder (Data Sheet B is contained in Volume – III.

Data Sheet – C indicates data/ documents to be furnished after the award of contract as per agreed schedule by the vendor (as applicable).



TITLE

**AUXILIARY STEAM PRESSURE REDUCING
& DESUPERHEATING STATION**

4X270 MW BHADRADRI TPS

SPEC. NO.: PE-TS-405-142-N101

VOLUME **II-B**

SECTION **CONTENTS**

REV NO. **00** DATE 13.07.2015

SHEET 1 OF 2

CONTENTS

<u>SECTION</u>	<u>TITLE</u>	<u>SPECIFICATION NO</u>	<u>NO. OF SHEETS</u>
Section-A	Scope of enquiry		3
Section-B	Project Information 4X270 MW BHADRADRI TPS		2
Section-C	Specific Technical Requirements		14
1.00	Brief System Description		
2.0.0	Equipment to be provided by tenderer		
3.0.0	Specific technical requirements		
4.0.0	Spares, consumable and specified tools & tackles (for all units)		
5.0.0	Spares		
6.0.0	Information to be furnished along with the offer by bidder		
7.00	Drawing		
8.00	Quality Plan		
9.0.0	Hook up Diagram		
Data Sheet - A 1	Sizing Data For High Capacity Aux. Steam PRDS (PRV AS-10) Spray Control Valve (CD-65) and Desuperheater-1 (DESH-1)		
Data Sheet - A 2	Sizing Data For Aux. Steam PRDS (AS-16)		
Data Sheet - A 3	Sizing Data For LT Desuperheater (DESH-2) & Spray Control Valve (CD-70)		



TITLE

**AUXILIARY STEAM PRESSURE REDUCING
& DESUPERHEATING STATION**

4X270 MW BHADRADRI TPS

SPEC. NO.: PE-TS-405-142-N101

VOLUME **II-B**

SECTION **CONTENTS**

REV NO. **00** DATE 13.07.2015

SHEET 2 OF 2

			<u>SHEETS</u>
<u>SECTION</u>	<u>TITLE</u>	<u>SPECIFICATION/ DRG/DOC NO</u>	<u>NO. OF</u>
Section D	Equipment Specification Specification For Control Valve (With Pneumatic/Electric Actuator)	PES – 145 – 06	1+1+11
Data Sheet A&B	Data Sheet For Control Valves (With Pneumatic Actuator) for tag nos. AS-10, AS-16, CD-65, CD-70.		10
	Data Sheet For Control Valves (With Pneumatic Actuator) Common for all Control Valves		
	Equipment Specification Steam Desuperheater	PES-148-01	1+3
Data Sheet –A1	Data for HT DesuperHeater DESH-1		1
Data Sheet –A2	Data for LT DesuperHeater DESH-2		1
Data Sheet C	List of Documents and Data to be Submitted after Award of Contract		2
Quality Plan	Quality Plan for Control Valve	PE-QP-411-145-I006	7
	Quality Plan for Steam DeSuperheater		2
Tender Drawings	Auxiliary Pr. Reducing and DeSuperHeating Station	PE-TS-411-142-N102	1+1

FILLED-UP QUALITY PLAN AS MINIMUM REQUIREMENTS IS INCLUDED
FOR CONTROL VALVE & STEAM DESUPERHEATER.



TITLE
SCOPE OF ENQUIRY
**AUXILIARY STEAM PRESSURE REDUCING
& DESUPERHEATING STATION**
FOR
4X270 MW BHADRADRI TPS

SPEC. NO.: PE-TS-411-142-N101

VOLUME **IIB**

SECTION **A**

REV NO. **00** DATE 13.07.2015

SHEET 1 OF 3

SECTION – A
SCOPE OF ENQUIRY



TITLE
SCOPE OF ENQUIRY
AUXILIARY STEAM PRESSURE REDUCING
& DESUPERHEATING STATION
FOR
4X270 MW BHADRADRI TPS

SPEC. NO.: PE-TS-411-142-N101

VOLUME **IIB**

SECTION **A**

REV NO. **00** DATE 13.07.2015

SHEET **2** OF **3**

- 1.1 This enquiry covers the Design, Manufacture, Assembly, Inspection and Testing at Vendor's and/or his sub-vendors works, painting and delivery to site of Auxiliary Steam Pressure Reducing & Desuperheating Stations, as mentioned in different sections of this specification for 4X270 MW Bhadradri TPS.

The tenderer shall also quote separately for the following:-

- a) Supervision of erection & commissioning of the equipment, if applicable.
- b) Recommended spares for 3 years of post guarantee period operation.

- 1.2 It is not the intent to specify herein all the details of design and manufacture. However, the equipment shall conform in all respects to high standards of design, engineering and workmanship and shall be capable of performing the required duties in a manner acceptable to the Engineer/Owner who will interpret the meaning of drawings and specifications and shall be entitled to reject any work or material, which in his judgment is not in full accordance herewith.

- 1.3 The bidder may quote for his standard, proven design of equipment and shall indicate any deviations from this specification in the enclosed schedule. **In the absence of duly filled deviation schedule, it shall be presumed that the offer conforms exactly to this specification.** The bidder shall also furnish the performance feedback data of the equipment from similar installations. However, the acceptance of the deviations/options is not binding on the Engineer/Owner.

- 1.4 The bids shall be in English language and MKS Units.

- 1.5 Filled up quality Plans as minimum technical requirements, are included in this specification in Vol. IIB Sec D. Bidder is required to submit the enclosed Quality Plan, or bring out specific deviations on it, while submitting the bid.

- 1.6 Similar to Quality Plan, Bidder is required to furnish Field Quality Plan (FQP), if applicable. FQP shall indicate all inspection/test to be carried out at site covering the following:

- i). Receipt of material.
- ii). Storage or Conservation.
- iii). Pre-Erection & Erection
- iv). Pre-Commissioning, commissioning & post commissioning.

FQP shall furnish adequate instructions to be followed by erection & commissioning agency at site.



TITLE
SCOPE OF ENQUIRY
**AUXILIARY STEAM PRESSURE REDUCING
& DESUPERHEATING STATION**
FOR
4X270 MW BHADRADRI TPS

SPEC. NO.: PE-TS-411-142-N101

VOLUME **IIB**

SECTION **A**

REV NO. **00** DATE 13.07.2015

SHEET 3 OF 3

Bidder is requested to refer standard no PES-1 00-918 on field quality plan enclosed in Volume III of this specification.

- 1.7 The omission of specific reference to any component / accessory necessary for the proper performance of the equipments shall not relieve the supplier of the responsibility of providing such facilities to complete the supply within the quoted prices.
- 1.8 BHEL's / TSG ENCO's representatives shall be given access to the shop in which the equipments are being manufactured or tested and all test records shall be made available to him.
- 1.9 The Equipment covered under this specification shall not be dispatched unless the same have been finally inspected, accepted and Material Dispatch Clearance Certificate (MDCC) is issued by BHEL / TSGENCO.



TITLE

PROJECT INFORMATION

**AUXILIARY STEAM PRESSURE REDUCING
& DESUPERHEATING STATION**

4X270 MW BHADRADRI TPS

SPEC. NO.: PE-TS-405-142-N101

VOLUME **II-B**

SECTION B

REV NO. **00** DATE 13.07.2015

SHEET 1 OF 2

SECTION – B

PROJECT INFORMATION



TITLE
PROJECT INFORMATION
**AUXILIARY STEAM PRESSURE REDUCING
& DESUPERHEATING STATION**
4X270 MW BHADRADRI TPS

SPEC. NO.: PE-TS-405-142-N101

VOLUME **II-B**

SECTION B

REV NO. **00** DATE 13.07.2015

SHEET 2 OF 2

1. INTRODUCTION

4x270 MW Bhadradi TPS is being set up by Telangana State Electricity Corporation Limited (TSGENCO) at Manuguru in the district of Khammam, Telangana, India.

The Bidder shall acquaint himself by a visit to the site, if felt necessary, with the conditions prevailing at site before submission of the bid. The information given here in under is for general guidance and shall not be contractually binding on BHEL/Owner. All relevant site data /information as may be necessary shall have to be obtained /collected by the Bidder.

2. APPROACH TO SITE

The distance from Manuguru to Major cities in state: Hyderabad-345KM, Warangal-180km, Bhadrachalam-38km, Kothagudem-70km and Khammam-130km, Vijayawada-195km.

District: KHAMMAM

State: TELANGANA

Nearest Airport: The nearest airport is Vijayawada Airport but the most used airport is the Hyderabad International Airport.

Nearest Railway Station: Manuguru railway station is 10KM from nearby town. However Warangal/Vijaywada railway Station is major railway station near to Manuguru.

3. TEMPERATURE

- Mean daily minimum ambient temperature during oldest month of the year=11.5 Deg.C
- Mean daily minimum ambient temperature during hottest month of the year=45.1 Deg.C

4. RAINFALL

Intensity of rainfall @ 80 mm/hr considering heaviest fall in 24 hrs

5. WIND DATA

- Basic wind speed at 10m height : 44 m/sec
- Wind pressure : As per IS: 875 Part III- 1987

6. SEISMIC ZONE

Zone III as defined in IS: 1893 (part-1)-2002 according to Indian Standard Seismic Zoning Map



TITLE
SPECIFIC TECHNICAL REQUIREMENTS
AUXILIARY STEAM PRESSURE REDUCING
& DESUPERHEATING STATION
FOR
4X270 MW BHADRADRI TPS

SPEC. NO. PE-TS-405-142-N101

VOLUME **II-B**

SECTION **C**

REV NO. **0** DATE 13.07.2015

Sheet 1 of 14

SECTION-C
SPECIFIC TECHNICAL REQUIREMENTS



TITLE
SPECIFIC TECHNICAL REQUIREMENTS
AUXILIARY STEAM PRESSURE REDUCING
& DESUPERHEATING STATION
FOR
4X270 MW BHADRADRI TPS

SPEC. NO. PE-TS-405-142-N101

VOLUME **II-B**

SECTION **C**

REV NO. **0** DATE 13.07.2015

Sheet 2 of 14

1.0.0 BRIEF SYSTEM DESCRIPTION

1.1.0 The system comprises of two auxiliary steam pressure reducing and desuperheating stations (PRDS). One "High capacity PRDS" with tapping off steam from main steam line to meet auxiliary steam requirements during unit start-up, low loads & for fuel oil system, and the other "Low Capacity PRDS" with tapping off steam from CRH line to meet auxiliary steam requirements during normal running. Spray water required for desuperheating will be tapped off from CEP discharge.

1.2.0 These two stations will reduce the pressure and temperature of the steam tapped off from CRH line and main steam line to 14 kg/cm² (abs) & 320oC at the high temperature auxiliary steam header and subsequently to 14 kg/cm² (abs) & 210oC at the low temperature auxiliary steam header through a suitable desuperheater between the high temperature and low temperature auxiliary steam headers.

2.0.0 EQUIPMENT TO BE PROVIDED BY TENDERER (AUXILIARY STEAM PRDS COMPRISING OF)

2.1.1 Control Valves & Accessories:

2.1.1.1 High Capacity PRV on MS line (AS-10) : One No. for each unit (total four units)

2.1.1.2 Low Capacity PRV on CRH Line (AS-16) : One No. for each unit (total four units)

2.1.1.3 Spray Control Valve for HC-DESH (CD-65) : One No. for each unit (total four units)

2.1.1.4 Spray Control Valve for LT-DESH (CD-70) : One No. for each unit (total four units)

2.1.1.5 Each control valve shall be supplied with the accessories specified in the relevant data sheets at Section-D.

2.1.2 Desuperheaters :

2.1.2.1 Direct mixing type HC desuperheater (DESH-1) : One No. for each unit (total four units)

2.1.2.2 Direct mixing type LT desuperheater (DESH-2) : One No. for each unit (total four units)

2.1.2.3 The desuperheater shall be complete with pipe, spray nozzle along with necessary attachment as specified in section-D.

Insertion type desuperheaters suitable for mounting on owners pipe or having 'moving part/elements' in heated zone (i.e. steam zone) is not acceptable.

3.0.0 SPECIFIC TECHNICAL REQUIREMENTS

The requirements in this section are specific for this project and shall over-ride the specification under section D in case of any contradiction.



TITLE
SPECIFIC TECHNICAL REQUIREMENTS
AUXILIARY STEAM PRESSURE REDUCING
& DESUPERHEATING STATION
FOR
4X270 MW BHADRADRI TPS

SPEC. NO. PE-TS-405-142-N101

VOLUME **II-B**

SECTION **C**

REV NO. **0** DATE 13.07.2015

Sheet 3 of 14

1. **All the formats in Volume-III, SCHEDULE OF SUBMISSION OF DRG./DOC. and QUALITY PLAN (BHEL Format) should filled-up and furnished with the bid, complete in all respect. In the absence of those, the bid would be considered incomplete and liable for rejection.** Catalogue, Leaflets related with the models of Control Valves as well as each Accessory must be furnished with the offer.
2. The Hook-up diagram for Control valve, is attached. The scope demarcation as indicated should be adhered. The connection details at Instrument Air valve shall be furnished to successful bidder after the award of contract.
3. Valve Body Sizes shall be quoted to take care of the specification requirements like parameters, and limitations of Fluid outlet velocities, Noise Level etc. **However Port (Trim) Sizes shall be selected to suit CV requirement for achieving percentage valve lift as per Technical Specification.**
4. Bidder to note that, **wherever downstream side of the valve is subjected to the Vacuum service, bidder to offer double Gland packing, and in that case, flow direction of working fluid shall be to close the valve.** Separate indication for the same has not been made in the data sheets-A.
5. For valves subjected to cavitation service, anti-cavitation trim shall be provided.
6. In case during erection/commissioning of the control valve, any spares are required which have not been specified in the Start-up/commissioning spares list, the same will have to be supplied by the bidder free of cost
7. Facility to adjust the maximum travel of the stem & starting point of travel shall be incorporated.
8. SS nameplate to control valve shall include Tag no./ KKS no./ Sl. No./ Body material/ size/ Press Rating/ Trim material/ Trim type/ action on air failure/ diaphragm air press at full open and close condition
9. Hand wheel shall have open/ close direction.
10. Limit switch shall be designed for 1,00,000 operations.
11. JB shall be 36 ways as per enclosed hook-up diagram.
12. The material of filter for Air Filter Regulator shall be Sintered bronze.
13. Bidder to indicate pick-up & drop out voltage for all solenoid valves.
14. Protection class for Limit switches, I/P converter and Position transmitter shall be IP-65 only.
15. All JBs and valves shall be with double compression type Ni plated brass cable glands.
16. Solenoid valve class of protection shall be IP-65.
17. All local cabling up to JBs shall be in Conduit (Flexible/Rigid). If JB is not mounted near valve
18. Noise Reduction shall be made through inherent design and not through external means.



TITLE
SPECIFIC TECHNICAL REQUIREMENTS
AUXILIARY STEAM PRESSURE REDUCING
& DESUPERHEATING STATION
FOR
4X270 MW BHADRADRI TPS

SPEC. NO. PE-TS-405-142-N101

VOLUME **II-B**

SECTION **C**

REV NO. **0** DATE 13.07.2015

Sheet 4 of 14

SPARES: The following spares are required to be offered

A. Recommended Spares:

The bidder shall furnish a List of Recommended spares for 3 years of normal operation of the Control valves / Accessories. The BHEL/ Customer reserves the right to buy any or all of the recommended spares.

B. Start-up & Commissioning Spares:

Start-up and Commissioning spares are those spares, which may be required during the start-up and commissioning of the Control Valves. All start-up spares, which are supplied under this contract, shall be strictly interchangeable with the parts for which they are intended for replacements. The format for price schedule to be filled-up by the bidder is enclosed in Volume-III. The Start-up and commissioning spares indicated by the bidder shall be a part of the main Control valves supply. However bidder to indicate prices separately. The list of these spares required is enclosed in the section-D of this specification.

Bidder to indicate the service life expectancy period for the spare parts under normal working conditions. The spares shall be treated and packed for long storage, under climatic conditions prevailing at site. Small items shall be packed in sealed transparent plastic bags with desiccator's packs as necessary.

19. Documentation:

(A) Along with the bids: following documents for the project

- a) Signed and stamped compliance certificates in attached format(VOL.-III).
- b) "Schedule of prices" and "Schedule of unit Prices" in attached format (VOL.-III).
- c) Schedule of submission of Drg. / Doc, Equip. Manufacture, Inspection and Dispatch.
- d) Inspection schedule
- e) Quality Plan Duly signed and Stamped

(B) After the award of contract:

The documentation as listed below for the project

6 sets of the following documents + 3 sets of CDs to be enclosed with the bids for

Approval:

- a. Assembly (dimensional) drawings.
- b. Valve Edge preparation details.
- c. Data sheet-C completely filled-up.



TITLE
SPECIFIC TECHNICAL REQUIREMENTS
AUXILIARY STEAM PRESSURE REDUCING
& DESUPERHEATING STATION
FOR
4X270 MW BHADRADRI TPS

SPEC. NO. PE-TS-405-142-N101

VOLUME **II-B**

SECTION **C**

REV NO. **0** DATE 13.07.2015

Sheet 5 of 14

- d. Hook-up diagram of Control Valve with Actuator & Accessories.
- e. Valve & Actuator assembly dimensional drawings with weights.
- f. Quality Plan duly signed and stamped.

- g. All calculations like CV, Noise Level, Valve Outlet Velocity, Actuator sizing etc.

- h. All relevant catalogues for the models of the valves as well as accessories finalized.
- i. Bar chart to indicate the time schedule for procurement, manufacture, testing and dispatch.

(B) Final documentation:

The documentation as listed below will separate for respective projects

- 1. Category -I & IV Approved final drawings/data sheets, - 20 sets with 4 CD-ROMS
Valve sizing calculations, Noise level calculations and
Valve Outlet Velocity calculations.
- 2. Test certificates - 20 sets.
- 3. Operation & Maintenance Manuals - 20 sets with 4 CD-ROMS
for Control Valve, Actuator and all the Accesories

NOTES : 1. Packing instructions :- Packing boxes shall have clear marking "To be stored indoor, away from water and dust."



TITLE
SPECIFIC TECHNICAL REQUIREMENTS
AUXILIARY STEAM PRESSURE REDUCING
& DESUPERHEATING STATION
FOR
4X270 MW BHADRADRI TPS

SPEC. NO. PE-TS-405-142-N101

VOLUME **II-B**

SECTION **C**

REV NO. **0** DATE 13.07.2015

Sheet 6 of 14

4.0.0 SPARES, CONSUMABLE AND SPECIFIED TOOLS & TACKLES (For all Units):

4.1.1 Commissioning Spares & Consumables

The bidder shall supply spares and consumables for all the above valves & desuperheater required during start-up. A list of all spares and consumables to be supplied shall be submitted along with the bid.

4.1.2 Recommended Spares

The bidder shall submit a list of recommended spares for all the above valves and desuperheaters for three years of normal operation. These are to be quoted separately & unit prices to be indicated, to enable placement of a separate order later if required.

4.1.3 Special Tools & Tackles

The bidder shall supply one complete set of special tools & tackles required for the erection, assembly, disassembly & maintenance of the equipment. A list of such tools & tackles to be supplied shall be submitted along with the bid.

4.1.4 Bidder to indicate the service life expectancy period for the spare parts under normal working conditions. The spares shall be treated and packed for long storage under climatic conditions prevailing at site. Small items shall be packed in sealed transparent plastic bags with desiccators' packs as necessary.

5.0.0 SPARES: The following spares are required to be offered.

a) Stat-up & Commissioning spares:

- i) Start-up and Commissioning spares are those spares, which may be required during the start-up and commissioning of the Control Valves. All start-up spares, which are supplied under this contract, shall be strictly interchangeable with the parts for which they are intended for replacements. The format for price schedule to be filled-up by the bidder is enclosed in Volume-III
- ii) The Start-up and commissioning spares indicated by the bidder shall be a part of the main Control valves supply. However bidder to indicate prices separately. The list of these spares required to be supplied shall be submitted along with the bid.

LIST OF COMMISSIONING SPARES

S.No.	ITEM DESCRIPTION	QUANTITY REQUIRED (per unit)
1	Gaskets	One (1) set with each control valve Tag
2	Gland Packings	One (1) set with each control valve Tag
3	Cu Tubing	25 Meters of ¼ " PVC coated Cu. Tubing, with 1 set of Fittings for each CV



TITLE
SPECIFIC TECHNICAL REQUIREMENTS
AUXILIARY STEAM PRESSURE REDUCING
& DESUPERHEATING STATION
FOR
4X270 MW BHADRADRI TPS

SPEC. NO. PE-TS-405-142-N101

VOLUME **II-B**

SECTION **C**

REV NO. **0** DATE 13.07.2015

Sheet 7 of 14

5.1.0 LIST OF MANDATORY SPARES

A)	High capacity PRDS system (AS-10)		QUANTITY FOR STATION
i)	Pressure reducing cum desuperheating valves		
a)	Stem	1 no.	1
b)	Body seat rings	2 nos. for each type, size and rating of valves	2
c)	Gland packings	3 nos. for each type, size and rating of valves	3
d)	Gasket	3 nos.	3
iii)	Spray water line control valves		
	Valve trim including cage, plug, stem, , guide bushing steam packing	1 no. for each size, type and rating of valves	1
B)	Low capacity PRDS system (AS-16)		
i)	Pressure reducing cum desuperheating valves		
a)	Stem	1 no.	1
b)	Body seat rings	2 nos. for each type, size and rating of valves	2
c)	Gland packings	3 nos. for each type, size and rating of valves	3
d)	Gasket	3 nos.	3
iii)	Spray water line control valves		
	Valve trim including cage, plug, stem, guide bushings. steam packing	1 no. for each size, type and rating of valves	1



TITLE
SPECIFIC TECHNICAL REQUIREMENTS
AUXILIARY STEAM PRESSURE REDUCING
& DESUPERHEATING STATION
FOR
4X270 MW BHADRADRI TPS

SPEC. NO. PE-TS-405-142-N101

VOLUME **II-B**

SECTION **C**

REV NO. **0** DATE 13.07.2015

Sheet 8 of 14

6.0.0 INFORMATION TO BE FURNISHED ALONGWITH THE OFFER BY THE BIDDER.

The bidder shall submit four (04) sets of the following drawings and data along with the bid without which the offer will be deemed incomplete.

- 6.1.0. Un-prices Bill of Quantities (BOQ) for main package & mandatory Spares.
- 6.2.0. Calculations for valve sizing, actuator sizing, valve velocities and noise level.
- 6.3.0. Dimensioned outline drawing giving overall dimensions, material.
- 6.4.0. **Duly filled BHEL technical data sheets 'B'** for each control valve & desuperheater in the format as enclosed in volume III of this specification.
- 6.5.0. Hook-up diagram of control valves with actuator & accessories.
- 6.6.0. Reference list, Catalogue & Technical bulletins for various items being offered.
- 6.7.0. Any deviations from the specification / data sheet & reasons thereof.
- 6.8.0. Schedules as in Vol. III.
- 6.9.0. Quality Plan for the equipment offered in the format enclosed with this specification.
- 6.10.0. Field quality plan, if applicable
- 6.11.0. List of commissioning and recommended spares.
- 6.12.0. List of tools & tackles, if applicable
- 6.13.0. List of consumables / lubricants, if applicable

7.0.0 DRAWING

For general arrangement and terminal point details refer enclosed drawings nos. PE-TS-411-142-N102 in Volume II B Sec. D.



TITLE
SPECIFIC TECHNICAL REQUIREMENTS
AUXILIARY STEAM PRESSURE REDUCING
& DESUPERHEATING STATION
FOR
4X270 MW BHADRADRI TPS

SPEC. NO. PE-TS-405-142-N101

VOLUME **II-B**

SECTION **C**

REV NO. **0** DATE 13.07.2015

Sheet 9 of 14

8.0.0 QUALITY PLAN

The bidder shall furnish quality plan along with the offer and the same shall be finalized before the issue of LOI.

Detailed quality plan shall be submitted by the successful tenderer after the placement of order for each project during contract execution for final approval by BHEL / its customer. BHEL / its customer shall indicate Customer Hold Points (CHP) in the approved quality plan beyond which work shall not proceed without the approval of BHEL / its customer for any particular project during final execution.

The quality plans enclosed in volume-II-B 'D' of the specification are for bidder's guidance only and are not exhaustive. The bidder shall comply with these and other minimum requirements specified in the specification and shall furnish his own quality plan in BHEL/Customer formats in the event of order based on the guidance given as above for BHEL/Customer's approval.

STANDARD CONTROL VALVE HOOK-UP DIAGRAM (WITH SMART POSITIONER)

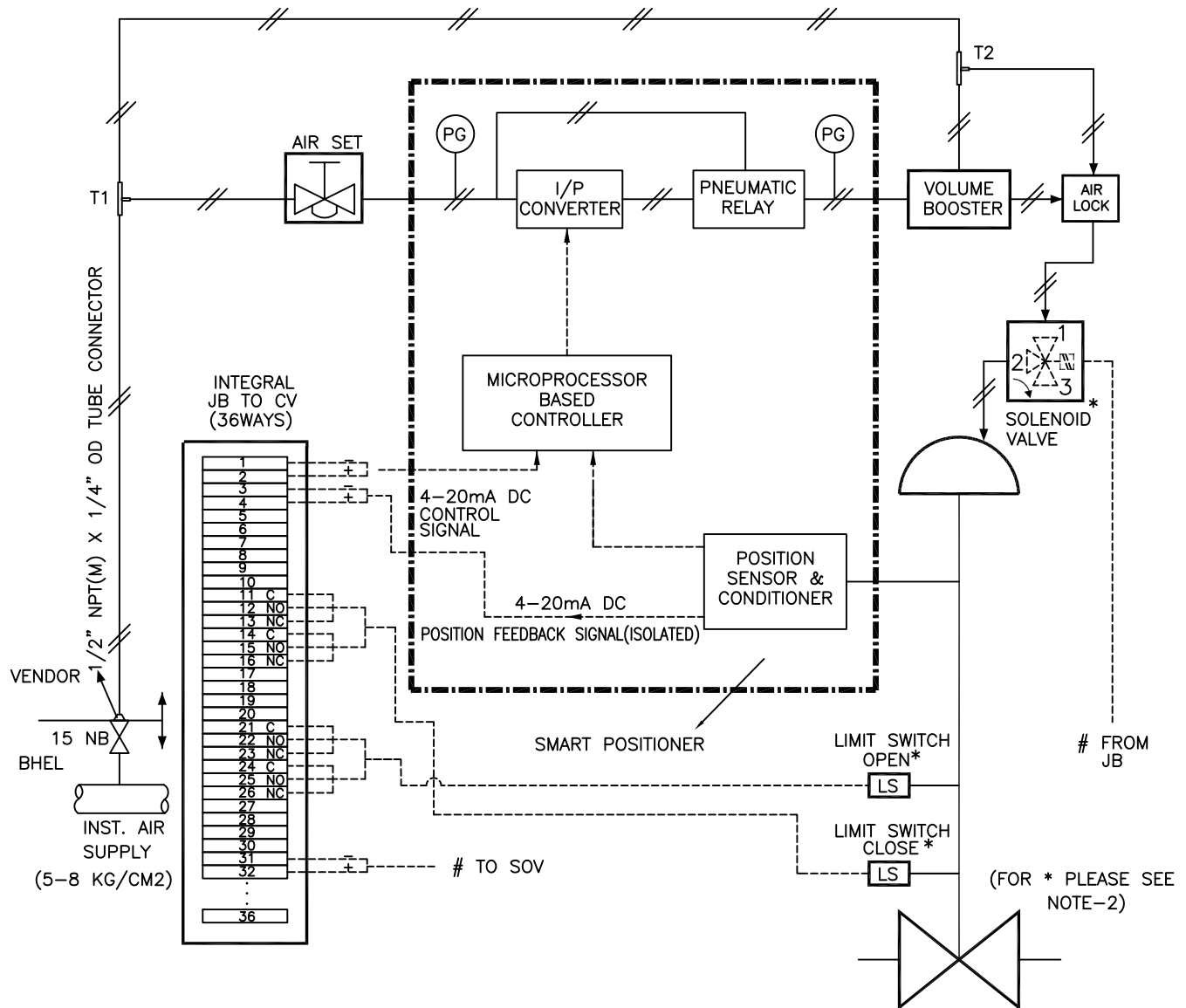

NOTES :-

1. POSITION OF EACH VALVE ON SUPPLY AIR FAILURE / ELECTRICAL SIGNAL FAILURE SHALL BE AS PER SPECIFICATION / DATA SHEET.
2. SOLENOID VALVE & LIMIT SWITCHES WILL BE PROVIDED ONLY FOR CONTROL VALVES IF INDICATED IN RESPECTIVE DATA SHEETS.
3. SOLENOID VALVES PORTS CONDITION:
PORT 1 AND 2 SHALL BE CONNECTED UNDER DE-ENERGISED CONDITION.
PORT 2 AND 3 SHALL BE CONNECTED UNDER ENERGISED CONDITION.
4. PRESSURE GAUGES REQUIRED FOR AIR SUPPLY & OUTPUT(S).
5. MOUNTING ACCESSORIES AS REQUIRED.
6. POSITION FEEDBACK SIGNAL SHALL BE 2 WIRE 4-20mA ISOLATED SIGNAL.
7. JB TERMINALS SHALL BE CAGE CLAMP TYPE SUITABLE FOR 2.5 SQ. MM COPPER WIRE. EXTERNAL CONNECTION, OF PLUG IN TYPE OR THROUGH CABLE GLAND, SHALL BE AS PER DATA SHEET
8. ALL APPLICABLE ACCESSORIES SHALL BE PROVIDED AS INDICATED IN THE INDIVIDUAL CONTROL VALVE DATA SHEET / ACCESSORIES DATA SHEET.
9. 12 METERS 1/4" PVC COATED COPPER / SS TUBING (AS PER ACCESSORIES DATA SHEET) & 1 SET OF FITTINGS TO BE SUPPLIED FOR EACH CONTROL VALVE FOR CONNECTION TO ISO VLV AT INST AIR HEADER ON ONE END AND TO AIR LOCK RELAY/AIR FILTER REGULATOR ON THE OTHER END. ALL THE BRASS / SS FITTINGS SHALL BE DOUBLE COMPRESSION TYPE.
10. VOLUME BOOSTER (ALONG WITH TEE-T2 AND RELATED TUBING & CONNECTORS) SHALL BE PROVIDED IF REQUIRED. AIR CONNECTION TO VOLUME BOOSTER FROM TEE-T2 SHALL BE PROVIDED.

	STANDARD	DRG. No.	PES-145-06B		
	TITLE:- CONTROL VALVE HOOK-UP DIAGRAM	REV. No.	0	DATE	08.12.14
		SHEET	10 of 14		

STANDARD CONTROL VALVE HOOK-UP DIAGRAM (DOUBLE ACTING PISTON ACTUATOR WITH SMART POSITIONER)

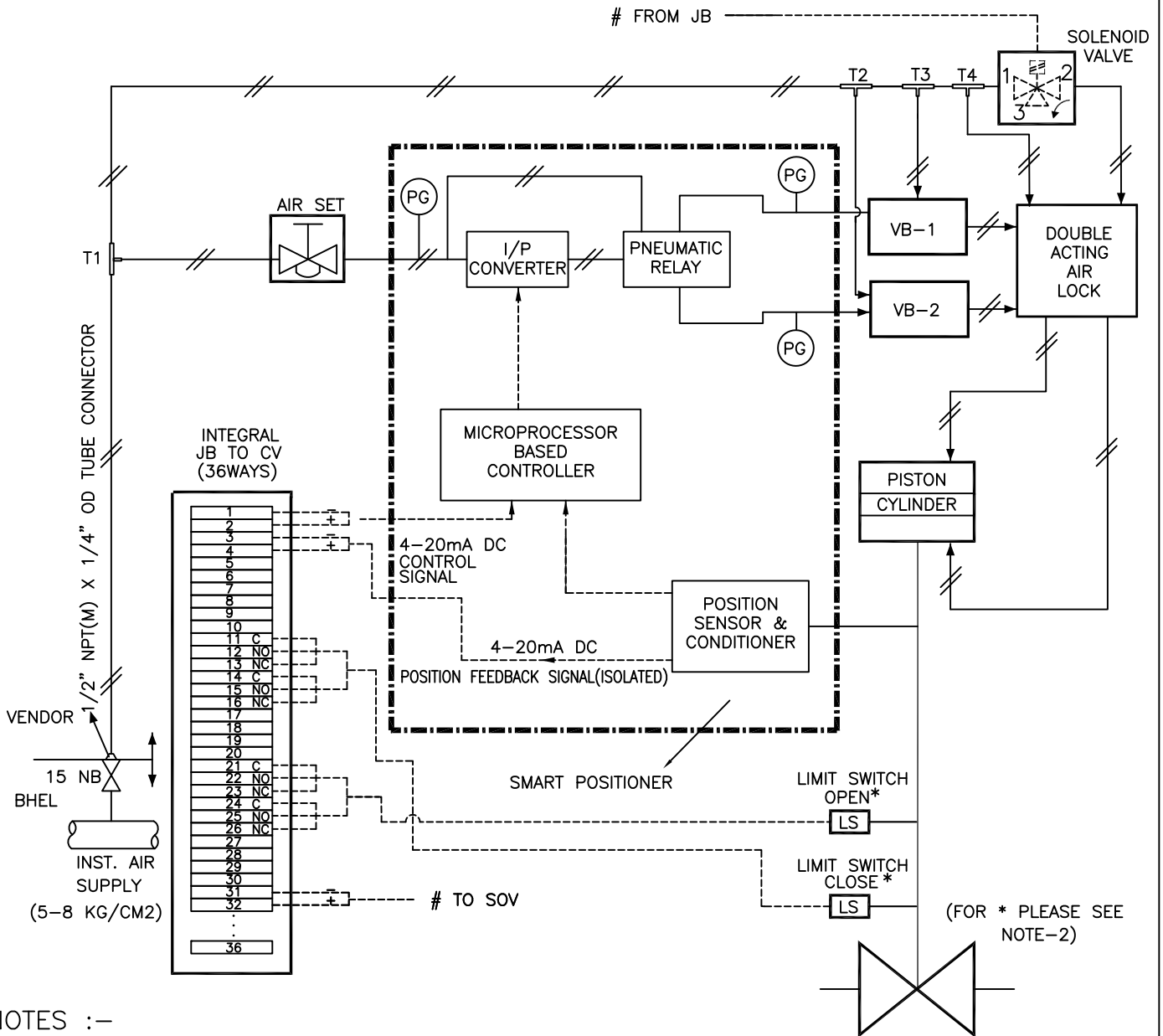

NOTES :-

1. POSITION OF EACH VALVE ON SUPPLY AIR FAILURE / ELECTRICAL SIGNAL FAILURE SHALL BE AS PER SPECIFICATION / DATA SHEET. AIR LOCK SHALL BE PROVIDED ACCORDINGLY.
2. SOLENOID VALVE & LIMIT SWITCHES WILL BE PROVIDED ONLY FOR CONTROL VALVES IF INDICATED IN RESPECTIVE DATA SHEETS.
3. SOLENOID VALVES PORTS CONDITION:
PORT 1 AND 2 SHALL BE CONNECTED UNDER DE-ENERGISED CONDITION.
PORT 2 AND 3 SHALL BE CONNECTED UNDER ENERGISED CONDITION.
4. PRESSURE GAUGES REQUIRED FOR AIR SUPPLY & OUTPUT(S).
5. MOUNTING ACCESSORIES AS REQUIRED.
6. POSITION FEEDBACK SIGNAL SHALL BE 2 WIRE 4-20mA ISOLATED SIGNAL.
7. JB TERMINALS SHALL BE CAGE CLAMP TYPE SUITABLE FOR 2.5 SQ. MM COPPER WIRE. EXTERNAL CONNECTION, OF PLUG IN TYPE OR THROUGH CABLE GLAND, SHALL BE AS PER DATA SHEET
8. ALL APPLICABLE ACCESSORIES SHALL BE PROVIDED AS INDICATED IN THE INDIVIDUAL CONTROL VALVE DATA SHEET / ACCESSORIES DATA SHEET.
9. 12 METERS 1/4" PVC COATED COPPER / SS TUBING (AS PER ACCESSORIES DATA SHEET) & 1 SET OF FITTINGS TO BE SUPPLIED FOR EACH CONTROL VALVE FOR CONNECTION TO ISO VLV AT INST AIR HEADER ON ONE END AND TO AIR LOCK RELAY/AIR FILTER REGULATOR ON THE OTHER END. ALL THE BRASS / SS FITTINGS SHALL BE DOUBLE COMPRESSION TYPE.
10. VOLUME BOOSTER (ALONG WITH TEE-T2 AND RELATED TUBING & CONNECTORS) SHALL BE PROVIDED IF REQUIRED. AIR CONNECTION TO VOLUME BOOSTER FROM TEE-T2 & TEE-T3 SHALL BE PROVIDED.



STANDARD

TITLE:-

CONTROL VALVE HOOK-UP DIAGRAM

DRG. No.

PES-145-06B

REV. No.

0

DATE

08.12.14

SHEET

11 of 14



TITLE
SPECIFIC TECHNICAL REQUIREMENTS
AUXILIARY STEAM PRESSURE REDUCING
& DESUPERHEATING STATION
FOR
4X270 MW BHADRADRI TPS

SPEC. NO. PE-TS-411-142-N101

VOLUME **II-B**

SECTION **C**

REV NO. **0** DATE 13.07.2015

Sheet 12 of 14

DATA SHEET- A-1
SIZING DATA FOR HIGH CAPACITY AUXILIARY STEAM PRDS (AS-10), SPRAY
CONTROL VALVE (CD-65)

SL.NO.	PARAMETERS	CASE 1	CASE 2	CASE 3	CASE 4	CASE 5	CASE 6	MECH. DESIGN
1.0	INLET PARAMETERS TO PRV (AS-10)							
1.1	PRESSURE (kg/cm ² (a))	36	83	150	150	85	54	167
1.2	TEMP. (°C)	350	490	537	537	490	370	540
1.3	FLOW (T/Hr)	BIDDER TO CALCULATE						
2.0	PARAMETERS AT DESUPERHEATER OUTLET (DESH-1)							
2.1	PRESSURE (kg/cm ² (a))	14	14	14	14	14	14	22
2.2	TEMP. (°C)	320	320	320	320	320	320	360
2.3	FLOW (T/Hr)	37.79	43.29	47.02	78.61	24.28	24.28	
3.0	INLET OF SPRAY CONTROL VALVE (CD-65)							
3.1	PRESSURE (kg/cm ² (a))	24	24	20	20	23	23	28
3.2	TEMP. (°C)	47	47	47	47	48	48	60
3.3	FLOW (T/Hr)	BIDDER TO CALCULATE						

NOTE:

1. CASE-1 IS THE CAPABILITY CHECK POINT FOR PRESSURE REDUCING AND DESUPERHEATING VALVE.
2. CASE-4 IS THE CAPABILITY CHECK POINT FOR SPRAY WATER SYSTEM.



TITLE
SPECIFIC TECHNICAL REQUIREMENTS
AUXILIARY STEAM PRESSURE REDUCING
& DESUPERHEATING STATION
FOR
4X270 MW BHADRADRI TPP

SPEC. NO. PE-TS-411-142-N101

VOLUME **II-B**

SECTION **C**

REV NO. **0** DATE 13.07.2015

Sheet 13 of 14

DATA SHEET- A-2

SIZING DATA FOR LOW CAPACITY PRV (AS-16)

SL.NO.	PARAMETERS	CASE-1	CASE-2	CASE-3	MECH. DESIGN
1.0	INLET OF PRV (AS-16)				
1.1	PRESSURE (kg/cm ² (a))	21.15	16.73	41.38	47.0
1.2	TEMPERATURE (°C)	328.8	319.9	345.9	360.0
1.3	FLOW (T/Hr)	3.55	7.89	6.02	
2.0	OUTLET OF PRV (AS-16)				
2.1	PRESSURE (kg/cm ² (a))	14	14	14	22
2.2	FLOW (T/Hr)	3.55	7.89	6.02	-



TITLE
SPECIFIC TECHNICAL REQUIREMENTS
AUXILIARY STEAM PRESSURE REDUCING
& DESUPERHEATING STATION
FOR
4X270 MW BHADRADRI TPP

SPEC. NO. PE-TS-411-142-N101

VOLUME **II-B**

SECTION **C**

REV NO. **0** DATE 13.07.2015

Sheet 14 of 14

DATA SHEET- A-3

SIZING DATA FOR LOW TEMPERATURE DESUPERHEATER (DESH-2)
& SPRAY CONTROL VALVE (CD-70)

SL.NO.	PARAMETERS	CASE 1	CASE 2	CASE 3	CASE 4	CASE 5	CASE 6	CASE 7	CASE 8	MECH. DESIGN
1.0	INLET OF DESUPERHEATER (DESH-2)									
1.1	PRESSURE (kg/cm ² (a))	14	14	14	14	14	14	14	14	22
1.2	TEMP. (°C)	320	320	320/ 318.7	320.0	320	320	320	317	360
1.3	FLOW (T/Hr)	BIDDER TO CALCULATE								
2.0	OUTLET OF DESUPERHEATER (DESH-2)									
2.1	PRESSURE (kg/cm ² (a))	14	14	14	14	14	14	14	14	22
2.2	TEMP. (°C)	210	210	210	210	210	210	210	210	360
2.3	FLOW (T/Hr)	19.30	19.30	3.9/6.6	51.60	64.10	19.30	19.30	5.90	
3.0	INLET OF SPRAY CONTROL VALVE (CD-70)									
3.1	PRESSURE (kg/cm ² (a))	23.75	23.75	22.14 / 20	20	20	22.54	22.54	22.14	28
3.2	TEMP. (°C)	47	47	47.5 / 46.8	46.8	46.8	47.8	47.8	47.5	60
3.3	FLOW (T/Hr)	BIDDER TO CALCULATE								

Note:

- CONDITION-5 IS THE CAPABILITY CHECK POINT FOR SPRAY WATER SYSTEM.**



TITLE

EQUIPMENT SPECIFICATIONS

**AUXILIARY STEAM PRESSURE REDUCING
& DESUPERHEATING STATION**

4X270 MW BHADRADRI TPS

SPEC. NO.: PE-TS-411-142-N101

VOLUME **II-B**

SECTION **D**

REV NO. **00** DATE 13.07.2015

SHEET 1 OF 1

SECTION – D

EQUIPMENT SPECIFICATIONS



TITLE

EQUIPMENT SPECIFICATIONS

**AUXILIARY STEAM PRESSURE REDUCING
& DESUPERHEATING STATION**

4X270 MW BHADRADRI TPS

SPEC. NO.: PE-TS-411-142-N101

VOLUME **II-B**

SECTION **D**

REV NO. **00** DATE 13.07.2015

SHEET 1 OF 1

SECTION – D

EQUIPMENT SPECIFICATIONS

FOR

CONTROL VALVE WITH PNEUMATIC ACTUATOR



**SPECIFICATION FOR CONTROL VALVE
(WITH PNEUMATIC / ELECTRIC ACTUATOR)**

SPECIFICATION NO.: PES – 145 - 06

VOLUME II B

SECTION D

REV. NO. 05

DATE : 15-05-2007

SHEET 1 OF 13

1.0 SCOPE

This specification covers the Design, Manufacture, Inspection and Testing at the manufacturer's works, proper packing for transportation and delivery to site of Control valve (with Pneumatic/Electric Actuator) for use in Utility/Captive Power Station/Combined Cycle Station.

2.0 CODES AND STANDARDS

2.1 All the equipments specified herein shall comply with the requirements of the latest issue of the relevant National and International standards.

2.2 The Design and Materials used for the components shall also comply with the relevant National and International standards.

2.3 As a minimum requirement, the following standards shall be complied with :

Indian Boiler Regulation (IBR)	:	
Allowable Seat leakage	:	ANSI-B16.104 / FCI-70.2
Pressure & Temperature ratings	:	ANSI-B16.34
Enclosure class	:	IEC-144 / NEMA / IS-13947
Control Valves	:	ISA S-75
Electric Motor operated Actuators	:	IS-9334

3.0 TECHNICAL REQUIREMENTS

The Control valve, Actuator and the accessories shall be suitable for continuous operation under an ambient temperature of 0-55°C and Relative Humidity of 0-95% unless specified otherwise in volume IIB Section-B or Section-C.

3.1 Control Valve

The control valve shall be suitably designed for the operating conditions and system characteristics as specified in the Data Sheet-A.

3.1.1 The control valve shall be of globe body design with single port. The valve trim, shall be suitable for quick removal without any cutting or welding.

3.1.2 The material of body, internals and packing shall be as specified in the data sheets. Alternatives, considered more suitable for service specified may be given as alternative offer, along with adequate justification. However main offer shall totally meet specification requirements. Asbestos shall not be used for the packing or any other component.

3.1.3 The valve bonnet and packing shall be suitable for the service conditions as in Data Sheet-A. Gland sealed type bonnets are not acceptable. Double packing is mandatory for applications involving vacuum service. Bonnets having teflon packing shall have valve stem finished to 2-4 microns. Packing material requiring lubrication will not be acceptable. Justification for proper selection of bonnet & packing shall be furnished in the bid.

3.1.4 The valve end connection as specified in Data Sheet-A shall conform to ANSI B16.25 for Butt Weld connection and ANSI B16.5 for flanged ends. End to end dimension shall be as per ANSI 16.10.

3.1.5 The valve seat leakage shall be as per ANSI B16.104 / FCI-70.2. The leakage class shall be as per Data Sheet-A.



**SPECIFICATION FOR CONTROL VALVE
(WITH PNEUMATIC / ELECTRIC ACTUATOR)**

SPECIFICATION NO.: PES – 145 - 06

VOLUME II B

SECTION D

REV. NO. 05

DATE : 15-05-2007

SHEET 2 OF 13

- 3.1.6 The valve body shall have the direction of flow embossed on all valves.
- 3.1.7 The sizing shall conform to the requirements of ANSI/ISA(S75- 01), and the valve capacity shall be selected so as to meet the following:
- | | | | | |
|--|---|---|---|--------------------|
| Valve with Linear characteristic. | - | Normal Flow (Design Point) | : | 70-75% valve lift. |
| | - | Max. Flow | : | 90% valve lift. |
| | - | Min. Flow | : | >10% valve lift. |
| Valve with Equipercentage Characteristic | - | Normal Flow (Design Point) | : | 75-85% valve lift. |
| | - | Max. Flow | : | 90% valve lift. |
| | - | Min. Flow | : | >10% valve lift. |
| ON/OFF Quick open Characteristic | - | 1.1 times the CV calculated on the basis of maximum flow condition. | | |
- 3.1.8 Calculation for valve sizing, velocity and noise shall be subject to purchaser's approval during contract stage. However responsibility of proper selection and design for the duties specified lies with the vendor. Any modifications required to be done on the valves or actuators & accessories to achieve satisfactory performance of the control system shall be done without any commercial implication.
- 3.1.9 Suitable justification and evidence shall be furnished regarding proper selection of the valve.
- 3.1.10 The valve outlet velocities shall be limited to the following values, unless otherwise specified in the Data sheet-A.
- | | | | |
|-----|----------------|----|--|
| i) | Liquid service | <= | 7 Metres/Sec. |
| ii) | Steam service | <= | 1/3 Sonic velocity in the flow medium. |
- 3.1.11 For flashing duty, the trim design shall be such that the vapour bubbles are kept away from valve body.
- 3.1.12 For cavitation service, the trim design shall be of multistage pressure drop type, so as to avoid cavitation altogether, instead of keeping cavitation away from valve parts.
- 3.1.13 In case of predicted noise level above 85 dBA, suitable low noise trim or inbuilt diffusers shall be provided to bring down the noise level below 85dBA.
- 3.1.14 The equivalent weighted sound level measured at 1.5M. above floor level in elevation and one metre horizontally from the control valve expressed in decibels to a reference of 0.0002 microbar shall not exceed 85 dBA (without pipe insulation). The offer shall include noise prediction calculations for each valve.
- 3.1.15 In case of wrong selection/mal operation of valve and for associated actuator during guarantee period, the vendor shall replace the valve suitably with a modified/new valve of design as approved by purchaser and all the expenses for replacement, rectification/modification including transportation both ways will be at vendor's expenses.



**SPECIFICATION FOR CONTROL VALVE
(WITH PNEUMATIC / ELECTRIC ACTUATOR)**

SPECIFICATION NO.: PES – 145 - 06

VOLUME II B

SECTION D

REV. NO. 05

DATE : 15-05-2007

SHEET 3 OF 13

3.2 Pneumatic Actuator

The pneumatic actuators shall be employed for modulating or open/close duty, as specified in Data Sheet-A. The bidder shall be responsible for proper selection and sizing of valve actuators in accordance with the pressure drops and shut off pressure.

3.2.1 The pneumatic spring opposed diaphragm actuator for modulating duty shall be capable of positioning the associated valve at desired opening for all the operating conditions specified.

3.2.2 The pneumatic actuator for open/close duty shall be suitable for fast opening/closing of the associated valve.

3.2.3 The actuator design shall allow valve assembly to be mounted at 45° inclination on either side in the vertical plane.

3.2.4 The actuators shall be suitably sized to ensure that the associated valve travel time from full open to full closed position and vice versa is less than 20 seconds under the most stringent service conditions.

3.2.5 The actuator shall be painted with epoxy based paint.

3.3 Accessories for Control valve with Pneumatic Actuator

The bidder shall offer all the accessories as specified in the Data Sheet - A for the Pneumatic Actuators under modulating or OPEN/CLOSE duty. The accessories specified shall be supplied duly mounted on the valve actuator and piped with PVC covered copper tube and flareless brass fittings (Refer typical hook up diagram in sheet 12 of 12).

3.3.1 Handwheel

Handwheel shall have OPEN & CLOSE direction marking and clockwise rotation as viewed from front shall close the valve. The handwheel shall have a circular stainless steel plate with Tag number and service.

3.3.2 Local Position Indicator

Each actuator shall be provided with a mechanical pointer attached to stem, moving over a graduated scale with markings, for OPEN, 25%, 50%, 75%, CLOSE positions.

3.3.3 Position Transmitter

The position transmitter shall be supplied as indicated in Data Sheet-A. The electronic position transmitter shall be non-contact type with 4-20 mA DC 2-wire output suitable for 12-50V DC supply. The resistance type position transmitter shall have 0-100 ohm variation for valve position change of 0-100%. The position transmitters of both types shall have accuracy and enclosure class. Necessary cable glands shall be supplied.



**SPECIFICATION FOR CONTROL VALVE
(WITH PNEUMATIC / ELECTRIC ACTUATOR)**

SPECIFICATION NO.: PES – 145 - 06

VOLUME II B

SECTION D

REV. NO. 05

DATE : 15-05-2007

SHEET 4 OF 1

3.3.4 Air Filter Regulator

Instrument quality air at suitable pressure of 5.5 Kg/Cm²(g) to 7 Kg/Cm²(g) shall be supplied to each valve through air filter regulator. The filter regulator shall include an inbuilt blow-down valve, 5 micron size filter. The design pressure for regulator shall be 7 Kg/cm²g. The Air filter regulator shall be selected to meet the requirements of positioner/actuator, E/P convertor and air-lock. The flow capacity of the Air filter regulator shall be variable with a knob. Output gauge shall be provided wherever pneumatic positioner is not specified for the valve.

3.3.5 Air Lock Relay

Air lock relay shall retain the valve position stayput, in case of air supply failure and shall reset automatically on resumption of air supply. Air lock shall have a threaded plug for evacuating diaphragm air if required for local manual operation.

3.3.6 Solenoid Valves

Solenoid valves are meant for interlock & protection purposes overriding the controller signal, and/or to result stayput action on controller signal failure. The Solenoid valve shall be 3-way **Universal** type and the valve internals shall be of stainless steel. The coil shall have class-H insulation and rated for continuous AC/DC duty as specified in Data sheet-A. The enclosure shall be to IP-55. Cable gland shall be provided for cable entry. The solenoid shall in general conform to IS-8935. The solenoid operation shall be universal type. The solenoid shall be suitable for 24V DC supply, unless specified otherwise in Data Sheet-A.

3.3.7 Limit Switches

Limit switches are required as specified in the data sheet-A. Each limit switch shall have 2NO+2NC contacts with contact rating of 5A at 240V AC/0.2A at 220V DC unless otherwise specified. The switch enclosure shall conform to IP-55. Each limit switch shall be supplied with cable glands.

3.3.8 I/P Converter

I/P Converters shall preferably be of force balance type and shall produce pneumatic output signal corresponding to input current signal, also specified in Data Sheet. Convertor electronics shall be protected against reverse connection of signal polarities and a separate external connection shall be provided to facilitate grounding of instrument casing. Cable glands with neoprene gromets suitable for PVC cables shall be provided. I/P convertor shall have span adjustment facility. I/P convertor enclosure shall conform to IP-55 enclosure class.

3.3.9 Positioner

Positioner shall be suitable for accepting controller output signal 0.2-1.0 Kg/cm², 0.2-0.6 Kg/cm² or 0.6-1.0 Kg/cm² as specified and give an output suitable for the actuator. Pneumatic positioner shall have 3 gauges. All gauges shall have metric scales. The positioner input signal range shall be adjustable. Wherever applicable, it shall be possible to bypass the positioner by means of a switch. **Linearity and Hysteresis shall be as indicated in Data sheet-A**

3.3.10 Electro pneumatic Positioner

In place of separate E/P Converter and pneumatic positioner a combined electro pneumatic positioner can also be supplied. The electro pneumatic positioner shall have 2 gauges.



**SPECIFICATION FOR CONTROL VALVE
(WITH PNEUMATIC / ELECTRIC ACTUATOR)**

SPECIFICATION NO.: PES – 145 - 06

VOLUME II B

SECTION D

REV. NO. 05

DATE : 15-05-2007

SHEET 5 OF 13

3.3.11 Junction Box

Wherever specified, an integral junction box with all electrical accessories conduited up to JB shall be supplied. The junction box shall have two (2) cable glands for outgoing cables. Junction box shall have enclosure class of IP-55.

3.4 Guarantee & Performance

3.4.1 The overall performance of the control valve with pneumatic actuator assembly shall be as follows:-

i)	Hysteresis	:	\pm 1% of span
ii)	Linearity	:	\pm 2% of span
iii)	Sensitivity	:	\pm 0.5% of span.
iv)	Repeatability	:	\pm 1% of span
v)	Accuracy (Overall)	:	\pm 2% of span

3.4.2 The guarantee for the control valve, pneumatic actuator & accessories shall be for 12 months continuous operation from the date of commissioning, unless specified otherwise in VOL-IIB Section-B or Section-C.

3.5 Electric Actuator

The electric actuator shall be employed for modulating duty.

3.5.1 The actuator assembly shall be complete with drive motors, gears, hand wheel, signaling & switching units, associated control, integral starter, (when specified) and other accessories as required.

3.5.2 The Electric Actuator shall be capable of positioning the associated valve at the desired opening for all the operating conditions.

3.5.3 The motor shall meet the requirements of Current, torque, Axial thrust, Accelerating & stall time as imposed by the driven equipment.

3.5.4 The motor shall be suitable for direct on line starting.

3.5.5 Motors shall be suitable for inching & plugging duty operations.

3.5.6 The motors shall be capable of starting and accelerating to rated speed at 85% of rated voltage.

3.5.7 The motors shall be rated for continuous operations for modulating duty.

3.5.8 The motor shall operate satisfactorily under the following conditions:

- i) \pm 10% supply voltage variation at rated frequency.
- ii) -5% to + 3% variation in frequency at rated supply voltage.

iii) Simultaneous variation in voltage and frequency, the sum of absolute percentage not exceeding 10%.

3.5.9 The Actuator shall be suitable for mounting directly on the valve and shall be suitable for mounting in any position. Supports required for inclined mounting shall form part of supply of valve assembly.

3.5.10 The actuator shall be capable of producing the required torque and thrust at the output shaft for satisfactory operation of the associated valve.



**SPECIFICATION FOR CONTROL VALVE
(WITH PNEUMATIC / ELECTRIC ACTUATOR)**

SPECIFICATION NO.: PES – 145 - 06

VOLUME II B

SECTION D

REV. NO. 05

DATE : 15-05-2007

SHEET 6 OF 13

- 3.5.11 Each actuator shall have a hand wheel for emergency operation. The hand wheel shall be designed such that it is declutched automatically when the power supply to the motor is restarted.
- 3.5.12 The hand wheel shall be so arranged that when looking from hand wheel, the valve is closed by rotating the hand wheel in clockwise direction.
- 3.5.13 Motor shall be totally enclosed conforming to IP-65 or better as per data sheet. The enclosure shall be suitable to protect the motor from leakage steam, water or oil from valve joints and glands.
- 3.5.14 Where flameproof enclosures are specified, it shall meet the specification IS-2148.
- 3.5.15 Insulation shall be at least class-B or better and shall be tropicalised to withstand the atmospheric condition.
- 3.5.16 The actuator shall be provided with antifriction bearing in grease filled cartridge.
- 3.5.17 Each actuator shall be provided with a mechanical position indicator to indicate accurately the valve position.
- 3.5.18 The integral starter, if specified in data sheet-A, shall be provided in weatherproof enclosure with protection class not less than IP-65 or better as per data sheet.

The integral starter shall consist of:

- i) Mechanical & Electrically interlocked reversing contractors suitable for class AC4 duty or Thyristor as per data sheet.
- ii) Thermal overload relay.
- iii) Step down control transformer with fuses.
- iv) Interposing relay.
- v) Monitoring relay..
- vi) Open, Close & Stop push buttons.
- vii) Indicating lamps.
- viii) Local-Remote lockable selector switch with spare potential free contacts, wired for remote interface.
- ix) A potential free contact shall be provided for remote annunciation of power failure/overload condition. The contact shall be SPDT, rated for at 5A 240V AC or 0.2A at 220V DC.



**SPECIFICATION FOR CONTROL VALVE
(WITH PNEUMATIC / ELECTRIC ACTUATOR)**

SPECIFICATION NO.: PES – 145 - 06

VOLUME II B

SECTION D

REV. NO. 05

DATE : 15-05-2007

SHEET 7 OF 13

- 3.5.19 The actuator shall be suitably time rated for the duty cycle involved with the necessary number of starts per hour, but in no case, less than 1200 starts per hour.
- 3.5.20 The actuator shall be provided with a suitable control unit for receiving 4-20 mA signal from remote controller.
- 3.5.21 The servomotor gear should have self locking or suitable brake so as to maintain it's last position as and when the motor power is switched off.
- 3.5.22 Thermostat/Thermistor as specified in the data sheet shall be provided for sensing the winding temperature and giving trip command. The trip contact shall be change over type. The contact shall be wired up to the actuator terminal box.
- 3.6 Accessories for Control Valve with Electric Actuator
- 3.6.1 Torque Switches
- i) Each actuator shall be provided with at least one open and one close torque switches each with 2 NO+2 NC contacts. The contacts shall be rated for 5A at 240V AC or 0.2A at 220V DC.
 - ii) The torque switches shall have a minimum accuracy $\pm 3\%$ of set value.
 - iii) The torque switches shall be provided with calibrated knobs for setting desired torque. Separate knobs shall be provided for close and open torque switches.
 - iv) The torque switches shall be provided with mechanical latching device to prevent operation when unsealing from the positions. The latching device shall unlatch as soon as the valve leaves the end position. If such provision is not possible, the torque switches shall be bypassed by end position limit switches, which open on valve leaving end position. These limit switches are additional to the number of limit switches specified elsewhere.
 - v) The torque switches or worm gear shall be self-locking type so that when torque switch operates it remains operated until the actuator is operated in the reverse.
 - vi) The torque switch enclosure shall conform to IP-55.
- 3.6.2 Limit Switches
- Each limit switch shall have 2NO+2NC contact with contacts rated for 5A 240V AC/0.2A 220V DC unless otherwise specified. The switch enclosure shall conform to IP-55. Each limit switch shall be supplied with cable glands.
- 3.6.3 Space Heater
- A space heater shall be provided in limit switch and starter compartments to prevent condensation. This shall be suitable for the power supply specified in the data sheet. Where integral starters are provided the space heaters shall be wired to control supply within the actuator.



**SPECIFICATION FOR CONTROL VALVE
(WITH PNEUMATIC / ELECTRIC ACTUATOR)**

SPECIFICATION NO.: PES – 145 - 06

VOLUME II B

SECTION D

REV. NO. 05

DATE : 15-05-2007

SHEET 8 OF 13

3.6.4 Remote Position Transmitter

The position transmitter shall be supplied as indicated in Data Sheet-A. The electronic position transmitter shall be non-contact type with 4-20mA DC 2-wire output suitable for 12-50V DC supply. The resistance type position transmitter shall have 0- 100 ohm variation for valve position change of 0-100%. The position transmitters of both types shall have $\pm 1\%$ accuracy. The enclosure shall conform to IP-55. Necessary cable glands shall be supplied.

3.6.5 Wiring

- i) The actuator and the accessories will be neatly wired up to the terminal boxes.
- ii) The internal wiring shall be minimum of 1 mm² stranded PVC insulated copper conductor.
- iii) The wiring shall be identified by means of numbered ferrules on both ends of all wires.

3.7 Terminal and Terminal boxes

3.7.1 Motor Terminal Box

- i) The terminals, terminal boards, terminal boxes, winding tails and associated equipment shall be suitable for connection to supply system having short circuit capacity specified in data sheet and clearance time determined by the associated fuses.
- ii) The terminals shall be stud type insulated from the frame. The insulation shall not be porcelain. The studs shall be of brass or stainless steel or phosphor bronze of adequate size.
- iii) The terminal box shall be totally enclosed conforming to degree of protection IP-65.

3.7.2 Actuator Terminal Box

- i) All terminals of limit and torque switches, space heater, position transmitters, thermostat/thermister shall be brought to a common terminal box. The enclosure shall be to degree of protection IP-65.
- ii) Terminal board with plug in connector shall be provided. Alternatively stud type or insertion type may be considered. Pinch screw type however will not be accepted. All terminals shall be shrouded to prevent accidental contact. Where stud type terminals are offered, it shall be as per clause 3.7.1 (ii).
- iii) There shall be at least five terminals spare to terminate spare cores of cable.

3.7.3 Cable Glands

The motor terminal box and actuator terminal box shall be provided with required number of double compression nickel plated brass cable glands to suit cable type and associated size.

3.7.4 Earthing Terminal

Two earthing terminal shall be provided on either side of motor and actuator terminal box.

3.7.5 Painting

The Actuator shall be painted with epoxy-based paint.



**SPECIFICATION FOR CONTROL VALVE
(WITH PNEUMATIC / ELECTRIC ACTUATOR)**

SPECIFICATION NO.: PES – 145 - 06

VOLUME II B

SECTION D

REV. NO. 05

DATE : 15-05-2007

SHEET 9 OF 13

4.0 TESTING AND INSPECTION

4.1 The bidder shall adopt suitable quality assurance plan to ensure that the equipments offered will meet the specification requirements in full.

4.2 The bidder shall furnish the Quality Plan in the format enclosed in volume-III. In case the Quality Plan(s) is/are included in volume-II B, the bidder shall furnish his Quality Plan strictly in line with the same. The Quality Plan shall be discussed and finalised with the technically accepted bidders before opening the price bid. The stages where purchaser would like to be associated for witnessing or verification of tests would be indicated by the purchaser in the Quality Plan before approval.

4.3 The following test shall be conducted as a minimum requirement.

4.3.1 Control Valve

- i) Radiographic tests on castings.
- ii) Dye penetrant tests on machined surface.
- iii) Ultrasonic tests for the forgings & bars of all valves with 60 Kg/cm² & higher ratings.
- iv) Hydrostatic tests as per ANSI B 16.34 prior to seat leakage tests.
- v) Valve closure and seat leakage tests as per ANSI B 16.104 / FCI-70.2.

4.3.2 Pneumatic Actuators

Functional test of actuator and each accessory.

4.3.3 Electric Actuator

- i) Routine tests on motors as per IS: 325.
- ii) Functional test on actuator and each accessory.
- iii) Insulation resistance and high voltage test.
- iv) Stall current & Stall torque test.
- v) Output shaft speed and torque of actuator and corresponding current tests.

4.3.4 Control valve with Actuator & Accessories fully assembled

- i) Functional tests of control valve operation along with actuator & accessories.
- ii) Dimension checks.

4.3.5 Type tests or Test Reports

- i) Valve lift vs. Flow test (**Cv Test**)
- ii) Degree of protection tests for the enclosures
- ii) Temperature rise test (**applicable for Electrical Actuator only**).
- iii) Type test for motor as per IS: 325.

4.4 Inspection will be conducted by BHEL and/or their authorised representatives as per the agreed inspection schedule. The inspection schedule will be submitted by the bidder, for BHEL's approval at contract stage. The cost of all tests and inspections will be deemed to have been included in the bid. For all the type tests covered under 4.3.5 above, "Type Test Certificates" as per agreed Quality Plan shall be furnished. In the absence of the same, such Type Tests shall be arranged at the Vendor's works in the presence of BHEL and/or their authorised representatives or in independent Test House/Laboratory approved by BHEL.

4.5 **The Standard QP is included in this specification to enable bidder to understand the extent of inspection and testing requirements to execute this job. The successful bidder has to follow the agreed QP, taking care of customer requirements mentioned in Sec-C and submit QP for final approval by BHEL / Customer.**



**SPECIFICATION FOR CONTROL VALVE
(WITH PNEUMATIC / ELECTRIC ACTUATOR)**

SPECIFICATION NO.: PES – 145 - 06

VOLUME II B

SECTION D

REV. NO. 05

DATE : 15-05-2007

SHEET 10 OF 13

5.0 SPARES AND CONSUMABLES

5.1 Commissioning Spares and consumables

As part of the main equipment supply, the bidder shall supply all commissioning spares and consumables required during Start-up,

5.2 Mandatory Spares

The bidder shall offer along with main offer, the Mandatory Spares as specified in Volume IIB Section-C of the specification. The Mandatory Spares offered shall be of the same make and type as the main equipment.

5.3 Recommended Spares

The bidder shall furnish a list of Recommended Spares along with the normal service expectancy period and frequency of replacement; quantities recommended for 3 years operation along with unit rate against each item to enable BHEL / BHEL's Customer to place a separate order later, if required.

5.4 Special Tools & Tackles

The bidder shall furnish a list of Special Tools & Tackles included in the bid.

6.0 DRAWINGS AND DOCUMENTS

6.1 The bidder shall furnish the following documents in required number of copies along with the bid:

6.1.1 Data sheet-B, completely filled-up along with all enclosures.

6.1.2 Wiring diagrams for Electrical Actuators.

6.1.3 Hook up diagrams of Control Valve with Actuator & accessories.

6.1.4 Valve & actuator assembly dimensional drawings with weights.

6.1.5 Quality Plan

6.1.6 All relevant Catalogs with detailed technical information.

6.1.7 Bar-chart to indicate the time schedule for procurement, manufacture, testing and despatch.

6.2 The successful bidder shall furnish the following documents in required number of copies to BHEL during the contract stage:

6.2.1 For approval

i) Dimensional drawings.

ii) Installation drawings with overall dimensions of the completed equipment and clearances for operation and maintenance.

iii) Data sheet-C, completely filled-up along with all the enclosures including the sizing calculations & noise calculations.

iv) Quality Plan.

v) Test Certificates.



**SPECIFICATION FOR CONTROL VALVE
(WITH PNEUMATIC / ELECTRIC ACTUATOR)**

SPECIFICATION NO.: PES – 145 - 06

VOLUME II B

SECTION D

REV. NO. 05

DATE : 15-05-2007

SHEET 11 OF 13

6.2.2 Final / As-built Drawings

Final / As-built drawings / CDs in required number of copies shall be submitted.

6.3 Operation & Maintenance Manuals

O&M Manuals in required number of copies shall be submitted. O&M manuals shall also contain storage and commissioning instructions.

7.0 MARKING AND PACKING

7.1 Marking

A stainless steel metal nameplate should be permanently fixed on each equipment giving its tag number and technical specifications.

7.2 Packing

All equipment / materials shall be suitably packed and protected for the entire period of dispatch, storage and erection against impact, abrasion, corrosion, incidental damage due to vermin, sunlight, high temperature, rain, moisture, humidity, dust, sea water spray (where applicable) as well as rough handling and delays in transit and storage in open.

55

8.0 APPLICABLE DATA SHEET FORMS

This document shall be read with one or more of the following data sheet forms :

- Data sheet A&B for Control Valve with Pneumatic Actuator
- Data sheet C for Control Valve with Pneumatic Actuator
- Data sheet A&B for Control Valve with Electric Actuator
- Data sheet C for Control Valve with Electric Actuator



**DATA SHEET FOR CONTROL VALVES
(WITH PNEUMATIC ACTUATOR)
For
4X270 MW BHADRADRI TPS**

SPECIFICATION NO.: PE-TS-411-142-N101		
VOLUME	II - B	
SECTION	D	
REV. NO.	0	DATE : 13.07.2015
SHEET	1	OF 10

**DATA SHEETS- A&B
FOR CONTROL VALVES**



**DATA SHEET FOR CONTROL VALVES
(WITH PNEUMATIC ACTUATOR)
FOR
4X270 MW BHADRADRI TPS**

SPECIFICATION NO.: PE-TS-411-142-N101

VOLUME II - B

SECTION D

REV. NO. 0

DATE :

SHEET 1 OF 10

INDEX

S. No.	TAG No.	SERVICE	SHEET REF.
1.	AS-10	MAIN STEAM TO AUXILIARY STEAM PRESSURE REDUCING VALVE (HC PRV)	2 - 3
2.	AS-16	COLD REHEAT STEAM TO AUXILIARY STEAM PRESSURE REDUCING VALVE (LC PRV)	4 - 5
3.	CD-65	SPRAY TO HIGH TEMP. DESUPERHEATER (DESH-1)	6 - 7
4.	CD-70	SPRAY TO LOW TEMP. DESUPERHEATER (DESH-2)	8 - 9
5.	-----	DATA SHEET FOR CONTROL VALVES, ACCESSORIES (APPLICABLE FOR ALL CONTROL VALVES)	10



**Technical specification for
Control Valves with Accessories
(Pneumatically Operated)**

Tag No..... Quantity.....

APPLICABLE FOR TAG Nos.WHEREVER STATEMENT "REQUIRED" INDICATED IN THE INDIVIDUAL CV DATA SHEETS

DATA SHEET – A& B for ACCESSORIES

**DATA SHEET – A FOR CONTROL VALVE (WITH PNEUMATIC ACTUATOR)
(TO BE FILLED BY PURCHASER)**
**DATA SHEET – B
(TO BE FILLED-UP BY BIDDER)**

POSITIONER	MFR. & MODEL NUMBER					
	BYPASS	GAUGES	ENCL. CLASS	<input checked="" type="checkbox"/> YES <input type="checkbox"/> NO	<input checked="" type="checkbox"/> THREE <input type="checkbox"/> TWO	<input checked="" type="checkbox"/> IP-55
	INPUT SIGNAL (Kg / Cm ²)			<input checked="" type="checkbox"/> 0.2 – 1.0	<input type="checkbox"/> 0.2 – 0.6	<input type="checkbox"/> 0.6 – 1.0
	OUTPUT SIGNAL (Kg / Cm ²)			TO SUIT ACTUATOR		
AIR FILTER REGULATOR TWO (2) Nos. PER CV	MFR. & MODEL NUMBER					
	AIR SUPPLY PRESS (Kg / Cm ² g)			<input checked="" type="checkbox"/> 7.0	<input type="checkbox"/>	
	OUTPUT PRESS (Kg / Cm ² g)			TO SUIT ACTUATOR		
	FILTER SIZE			5 MICRON		
AIR LOCK	MFR. & MODEL NUMBER					
	SET PRESS (Kg / Cm ²)					
	SUPPLY PRESS (Kg / Cm ²)			<input checked="" type="checkbox"/> 7.0	<input type="checkbox"/>	
	RESET TYPE			AUTO		
LIMIT SWITCH	MFR. & MODEL NUMBER					
	OPEN posn	INT posn	CLOSE posn	1 NO.	---	1 NO.
	CONTACT TYPE			SPDT 2 NO + 2 NC		
	RATING (AC / DC)			5A 240V AC AND 0.2A 220V DC		
	ENCLOSURE CLASS			<input checked="" type="checkbox"/> IP 64	<input type="checkbox"/>	
POSITION TRANSMITTER	MFR. & MODEL NUMBER			<input checked="" type="checkbox"/> Electronic (2-Wire) Contactless <input type="checkbox"/> OTHER		
	TYPE			PART OF SMART POSITIONER		
	SUPPLY					
	OUTPUT RATING					
	ACCURACY					
	ENCLOSURE CLASS					
SOLENOID VALVE	MFR. & MODEL NUMBER					
	RATING			<input checked="" type="checkbox"/> 24V DC <input type="checkbox"/> 220V DC <input type="checkbox"/> 240V AC <input type="checkbox"/>		
	TYPE			3-WAY (UNIVERSAL OPERATION TYPE)		
	OPERATION	QUANTITY		<input type="checkbox"/> Stayput <input type="checkbox"/> Interlock	<input type="checkbox"/> 1	<input type="checkbox"/> 2
	COIL INSULATION CLASS			CLASS - F		
HANDWHEEL	ENCLOSURE CLASS			<input checked="" type="checkbox"/> IP 65	<input type="checkbox"/> NEMA 4	<input type="checkbox"/>
	ORIENTATION			<input type="checkbox"/> TOP MOUNTED	<input checked="" type="checkbox"/> SIDE MOUNTED	
JUNCTION BOX	NO. OF WAYS			<input type="checkbox"/> 24-WAYS	<input type="checkbox"/> AS REQUIRED	<input checked="" type="checkbox"/> 36-Ways
	SIZE			AS REQUIRED		
	CABLE GLANDS (Size / Quantity)			AS REQUIRED (Double Compression Type).		
	ENCLOSURE CLASS			<input checked="" type="checkbox"/> IP 65	<input type="checkbox"/>	
I/P CONVERTER	INPUT SIGNAL	POWER SUPPLY		PART OF SMART POSITIONER		
	SPLIT RANGE					
	ENCLOSURE CLASS					
	LINEARITY					
	HYSTERISIS					
Cu. Tubing & Fittings / per CV	This is in addition to cu. Tubing and fittings which are integral part of CV			25 Meters of ¼" PVC coated Cu. Tubing, with 1 set of Fittings for each CV for connection to IA Header on one end and accessories on another end of CV.		

COMPANY SEAL

NAME

SIGNATURE

DATE



TITLE

EQUIPMENT SPECIFICATIONS

**AUXILIARY STEAM PRESSURE REDUCING
& DESUPERHEATING STATION**

4X270 MW BHADRADRI TPS

SPEC. NO.: PE-TS-411-142-N101

VOLUME **II-B**

SECTION **D**

REV NO. **00** DATE 13.07.2015

SHEET 1 OF 1

SECTION – D
EQUIPMENT SPECIFICATIONS
FOR
STEAM DESUPERHEATER



TITLE

EQUIPMENT SPECIFICATION

STEAM DESUPERHEATER

SPECIFICATION NO **PES-148-01**

VOLUME **II-B**

SECTION **D**

REV NO. **0** DATE 13.07.2015

SHEET **1 OF 3**

1.0.0 GENERAL

This standard specification covers the design, materials, construction features, manufacturing process, assembly, inspection and testing requirements, painting and packing requirements of Steam Desuperheater along with spray nozzle.

2.0.0 CODES AND STANDARDS

2.1.0 The design, manufacture, inspection and testing of the equipment shall comply with the requirements of the latest national and international codes and standards wherever applicable. Wherever the specific code requirements are specified herein, the same shall be adhered to.

In particular, the equipment shall be designed to comply with latest editions of the following standards

- (i) Indian Boiler Regulations (IBR).
- (ii) ASME Section - VIII / Div. - 1.
- (iii) Material specifications as per ASTM, AISI.

3.0.0 DESIGN AND CONSTRUCTIONAL FEATURES

3.1.0 The desuperheater shall be of direct mixing mechanical spray type. The assembly shall consist of desuperheater pipe with steam inlet and outlet & spray water connection along with spray nozzle. The spray nozzle shall direct the spray in the direction of steam flow for proper mixing and arranged in such position that direct impingement of spray water on desuperheater walls is avoided.

3.2.0 The spray nozzle shall be accurately sized for best results in total range as stipulated in the data sheet.

3.3.0 The desuperheater shall be complete with matching counter flanges including bolts, nuts, gaskets, necessary reducers / expanders to suit purchaser's pipe line and supporting legs / pads & holding down bolts as required.

3.4.0 The material of construction shall be as indicated in Data Sheet – A.



TITLE

EQUIPMENT SPECIFICATION

STEAM DESUPERHEATER

SPECIFICATION NO **PES-148-01**

VOLUME **II-B**

SECTION **D**

REV NO. **0** DATE 13.07.2015

SHEET **2 OF 3**

4.0.0 SHOP INSPECTION AND TEST

- 4.1.0 The bidder shall submit along with the offer the Quality Plans in the enclosed format together with all reference documents/standards etc. as applicable.
- 4.2.0 Indicative Quality Plans, specifying minimum checks and tests as considered necessary are enclosed along with this specification for compliance. These however are not intended to exhibit the total comprehensive testing programmes, which are the responsibility of the bidder.
- 4.3.0 Detailed Quality Plans to be submitted by the bidders should also include all the checks/tests carried out by the suppliers as part of their normal practice. The Quality Plans submitted by the bidders shall be subject to approval of BHEL/their Customer who reserves the right to ask for further checks during finalization of Quality Plans. BHEL/their Customer shall indicate customer hold points in the approved Quality Plans beyond which the work shall not proceed without their approval.
- 4.4.0 The supplier shall furnish their production programme along with scheduled dates of testing at least three months in advance to enable BHEL/their customer to plan for witnessing the tests identified as hold points.
- 4.5.0 Material identification and correlation with test certificates for all major components shall be essentially required. In absence of these, the material of each component shall be tested as per relevant specification for Chemical Composition and Mechanical properties i.e. Yield Stress, Ultimate Tensile Stress, Impact test, % Elongation, % Reduction in Area, Hardness etc. In addition, to ensure freedom from surface and sub-surface defects, suitable Non Destructive Testing shall also be carried out.
- 4.6.0 Following tests shall be done at Manufacturers' works during various stages as minimum requirement :
- 4.6.1 Visual examination of all components.
- 4.6.2 Check for weld joints for proper fit up, Dye Penetration Test after root run and final welding. 100% Radiographic test as per ASTM E 165 for all butt welds.
- 4.6.3 Verification of stress relieving chart if post-weld heat treatment is called for.
- 4.6.4 Check / test for pressure retaining bolts and nuts as per relevant Codes/Standards.
- 4.6.5 Dimension check for all components including surface finish.

	TITLE	SPECIFICATION NO PES-148-01	
	EQUIPMENT SPECIFICATION	VOLUME II-B	
	STEAM DESUPERHEATER	SECTION D	
		REV NO. 0	DATE 13.07.2015
		SHEET 3 OF 3	
4.6.6	Hydraulic Test to two times the rated design pressure for desuperheater body and other pressure retaining parts.		
4.6.7	Check for final completeness, cleaning, surface finish, appearance, identification, surface preparation, painting, marking and packing including spares.		
4.6.8	The equipment comes under the purview of IBR (Indian Boiler Regulations). All tests certificates duly signed by Chief Inspector (IBR) / authorized representatives shall be furnished in IBR from III-C.		
4.6.9	The particulars of proposed shop tests and process of test shall be submitted to BHEL/their Customer along with Quality Plan for approval.		
5.0.0	<u>PERFORMANCE REQUIREMENTS</u>		
	Bidder shall guarantee that equipment offered shall meet the rating and performance requirements as stipulated in this specification. In case it is not as per guarantee furnished by the bidder, the efficiency shall be made good by the bidder by rectification / replacement of defective parts within reasonable time at their own cost inclusive of cost of transportation both ways if required. The Purchaser is entitled to reject the equipment in case of repeated failures to meet the guaranteed performance.		
6.0.0	<u>PAINING</u>		
6.1.0	All foundry sand and loose material shall be removed and surface should be made thoroughly clean for further protection as required.		
6.2.0	A shop coat of paint, removable after installation at site, shall be applied to all steel surfaces and other exposed surfaces requiring corrosion protection during transit and storage at site.		
7.0.0	<u>PRESERVATION, MARKING AND PACKING</u>		
7.1.0	A Stainless Steel metal nameplate should be permanently fixed on each equipment giving its Tag. No. and technical specifications i.e. Service, Size, Pressure Rating etc.		
7.2.0	All equipments / materials shall be packed suitably and protected from impact, abrasion, corrosion, incidental damage due to vermin, Sun-light, high temperature, rain, moisture, humidity, dust, sea water (where applicable) as well as rough handling during entire period of dispatch, storage and erection including delays in transit and storage in open.		
7.3.0	Spares shall be packed separately and marked clearly for identification. These shall be specially packed for long storage without damage.		



**DATA SHEET FOR CONTROL VALVES
(WITH PNEUMATIC ACTUATOR)
FOR
4X270 MW BHADRADRI TPS**

SPECIFICATION NO.: PE-TS-411-142-N101	
VOLUME	II - B
SECTION	D
REV. NO.	0
DATE :	
SHEET	1 OF 2

DATA SHEET A1

DATA SHEET FOR DESUPERHEATER DESH-1

S.NO.	DESCRIPTION	UNITS	DATA FOR HIGH CAP. PRDS DESUPERHEATER
1.0	TAG NO.		DESH-1
2.0	STEAM PARAMETERS		(INLET OF DESUPERHEATER)
2.1	FLOW	T/HR	REFER SIZING DATA FOR HIGH CAPACITY AUX PRDS
2.2	PRESSURE	Kg/cm ² (a)	BIDDER TO DECIDE BASED ON SIZING DATA
2.3	TEMPERATURE	°C	BIDDER TO DECIDE BASED ON SIZING DATA
3.0	STEAM PARAMETERS (OUTLET OF DESUPERHEATER)		REFER SIZING DATA FOR HIGH CAPACITY AUX PRDS
4.0	SPRAY WATER PARAMETERS		(INLET OF DESUPERHEATER)
4.1	FLOW	T/HR	REFER SIZING DATA FOR HIGH CAPACITY AUX PRDS
4.2	PRESSURE	Kg/cm ² (a)	BIDDER TO DECIDE BASED ON SIZING DATA
4.3	TEMPERATURE	°C	REFER SIZING DATA FOR HIGH CAPACITY AUX PRDS
5.0	END DETAILS		(STEAM INLET / OUTLET)
5.1	TYPE / MATCHING PIPE	mm x mm	BW / 323.9 x 9.53
6.0	END DETAILS		(SPRAY WATER INLET)
6.1	TYPE / MATCHING PIPE		SW/ 33.4x4.55
7.0	MATERIALS OF CONSTRUCTION		
7.1	BODY		A217 WC9
7.2	PIPE		SA 335 P22
7.3	SPRAY NOZZLE WITH ASSEMBLY		SS 316
8.0	DESIGN PARAMETERS OF DESUPERHEATER (DESH-1)		
8.1	DESIGN PRESSURE	Kg/cm ² (g)	21
8.2	DESIGN TEMPERATURE	°C	490



**DATA SHEET FOR CONTROL VALVES
(WITH PNEUMATIC ACTUATOR)
FOR
4X270 MW BHADRADRI TPS**

SPECIFICATION NO.: PE-TS-411-142-N101

VOLUME II - B

SECTION D

REV. NO. 0

DATE :

SHEET 2

OF 2

DATA SHEET A2**DATA SHEET FOR DESUPERHEATER DESH-2**

S.NO.	DESCRIPTION	UNITS	DATA FOR LOW TEMP. DESUPERHEATER
1.0	TAG NO.		DESH-2
2.0	STEAM PARAMETERS		(INLET OF DESUPERHEATER)
2.1	FLOW	T/HR	REFER SIZING DATA FOR LOW TEMPERATURE DESUPERHEATER (DESH-2) & SPRAY CONTROL VALVE
2.2	PRESSURE	Kg/cm ² (a)	BIDDER TO DECIDE BASED ON SIZING DATA
2.3	TEMPERATURE	°C	BIDDER TO DECIDE BASED ON SIZING DATA
3.0	STEAM PARAMETERS (OUTLET OF DESUPERHEATER)		REFER SIZING DATA FOR LOW TEMPERATURE DESUPERHEATER (DESH-2) & SPRAY CONTROL VALVE
4.0	SPRAY WATER PARAMETERS		(INLET OF DESUPERHEATER)
4.1	FLOW	T/HR	REFER SIZING DATA FOR LOW TEMPERATURE DESUPERHEATER (DESH-2) & SPRAY CONTROL VALVE
4.2	PRESSURE	Kg/cm ² (a)	BIDDER TO DECIDE BASED ON SIZING DATA
4.3	TEMPERATURE	°C	REFER SIZING DATA FOR LOW TEMPERATURE DESUPERHEATER (DESH-2) & SPRAY CONTROL VALVE
5.0	END DETAILS		(STEAM INLET / OUTLET)
5.1	TYPE / MATCHING PIPE	mm x mm	BW / 273 x 6.35
6.0	END DETAILS		(SPRAY WATER INLET)
6.1	TYPE / MATCHING PIPE		SW / 33.4 x 4.55
7.0	MATERIALS OF CONSTRUCTION		
7.1	BODY		A216 WCB
7.2	PIPE		SA 106 GrB
7.3	SPRAY NOZZLE WITH ASSEMBLY		SS 316
8.0	DESIGN PARAMETERS OF DESUPERHEATER (DESH-2)		
8.1	DESIGN PRESSURE	Kg/cm ² (g)	21
8.2	DESIGN TEMPERATURE	°C	360



TITLE

EQUIPMENT SPECIFICATIONS

**AUXILIARY STEAM PRESSURE REDUCING
& DESUPERHEATING STATION**

4X270 MW BHADRADRI TPS

SPEC. NO.: PE-TS-411-142-N101

VOLUME **II-B**

SECTION **D**

REV NO. **00** DATE 13.07.2015

SHEET 1 OF 1

DATA SHEET-C

**LIST OF DOCUMENTS AND DATA TO BE SUBMITTED
AFTER AWARD OF CONTRACT**

The list of documents and data to be submitted by the successful bidder after the award of the contract are specified in Data Sheet - C.

The supplier shall after award of contract submit FIFTEEN (15) sets of the following documents for purchaser's approval / vetting.

- (i) Certified final drawings & data sheets as per cl. 4.0.0 of section-C.
- (ii) Quality Plans, Inspection/Test Reports as agreed with the Purchaser.
- (iii) Material and Hydraulic Test Certificates along with IBR form III C.
- (iv) Performance Test Procedures and Reports.
- (v) Field Quality Plan as agreed.
- (vi) Storage Instructions.
- (vii) List of Commissioning, Mandatory and Recommended Spares.
- (viii) List of Tools and Tackles required.
- (ix) List of lubricants.
- (x) Operation and Maintenance Instruction Manual.

NOTE: Above list is only tentative. Successful bidder shall prepare detailed schedule of Drawings/ Documents, which shall be mutually agreed and included in the contract document/ordering Specification.



TITLE
EQUIPMENT SPECIFICATIONS
**AUXILIARY STEAM PRESSURE REDUCING
 & DESUPERHEATING STATION**
4X270 MW BHADRADRI TPS

SPEC. NO.: PE-TS-411-142-N101

VOLUME **II-B**

SECTION **D**

REV NO. **00** DATE 13.07.2015

SHEET 1 OF 1

FINAL DOCUMENTATION

S.NO.	DESCRIPTION	INITIAL SUBMISSION FOR APPROVAL TO BHEL	COPIES FOR NTPC APPROVAL AFTER BHEL CLEARANCE
1.	Vendor drawing / document for approval Note : <ul style="list-style-type: none"> ▪ Initial subm issions with Rev. No. P0, P1, P2 etc. ▪ After BHEL clara nce, subm ission to NTPC with Rev. No. R0, R1, R2 etc. 	05+Soft Copy	18+Soft Copy
2.	Issue of action A/B/C Civil / Erection Drawings / documents for constructi on at site (for civil packages only)		8
3.	Release of finally approved drawings / documents (action A/E) i.e. distribution prints		22 + Soft Copy
4.	O&M Manuals	2 24	
5.	“As-Built” drawings		12



TITLE

EQUIPMENT SPECIFICATIONS

**AUXILIARY STEAM PRESSURE REDUCING
& DESUPERHEATING STATION**

4X270 MW BHADRADRI TPS

SPEC. NO.: PE-TS-411-142-N101

VOLUME **II-B**

SECTION **D**





REV NO. **00** DATE 13.07.2015

SHEET 1 OF 1

QUALITY PLAN

QUALITY PLAN FOR CONTROL VALVES

THE DOC IS REVISED IN LINE WITH DESIGN COMMENT dtd 14.05.2015
 VIDE DOC REF No. Lr.No. CPP/411 /bhadradri/BHEL-PEM/15/D.No.311
 /15, Dt: 14.05.15 AND MOM B/W BHEL-PEM & TSGENCO ON 22.05.15.

 TELANGANA STATE POWER GENERATION CORPORATION LTD													
										 DESEIN PRIVATE LIMITED			
JOB NO. 411 STATUS STANDARD DISTRIBUTION					PROJECT: BHADRADRI TPS, UNITS # 1 TO 4 (4X270 MW), MANUGURU, KHAMMAM DISTRICT								
TO					 BHARAT HEAVY ELECTRICALS LTD POWER SECTOR PROJECT ENGINEERING MANAGEMENT NQIDA					DEPT CODE	NAME	SIGN	DATE
No. of	REV.	DATE	ALTD	CHD	APPD	I	CHD	SS	-sd-	28.05.15			
APPD	MAM	-sd-	28.05.15										
TITLE QUALITY PLAN FOR CONTROL VALVES													
					DEPT. SCALE		DRAWING NO.						
					SIGN		PE-QP-411-145-1006						
					DATE				SHEET 00 OF 07 REV. 00				



PEM :: C&I

**4X270 MW BHADRADRI QUALITY PLAN
FOR
CONTROL VALVE (PNEUMATIC)**

QUALITY PLAN NO.: PE-QP-411-145-I 006

VOLUME

SECTION

REV. NO.

00

DATE: 28.05.2015

SHEET

1

OF

7

Sl. No.	Component / operation	Characteristics Checked	* Category	Type/Method of Check	Extent of Check	Reference documents	Acceptance Norms	Format of Records	Agency \$			Remarks
									P	W	V	
1.0 MATERIAL												
1.1	Body & Bonnet casting / forgings, plug, valve stem, seat ring/cage.	1. Physical, Chemical properties	MA	Physical, Chemical tests	One/ Heat(HT Batch)	Approved drg. / data sheet / BHEL specn.	Approved drg. / data sheet / BHEL specn.	Test Certificate	3	---	2,1	Any Forging >=40mm thick or >= 50mm dia shall be UT checked irrespective of rating.
		2. Heat Treatment	MA	Review of H.T. Chart	Each H.T.	Approved drg. / data sheet / BHEL specn.	Approved drg. / data sheet / BHEL specn.	Test Certificate	3/2	2	1	IBR Certification (if applicable) to be verified by BHEL
		3. Internal quality of castings	MA	RT for Body & UT for Bonnet(NDT)	100%	ASME B 16.34	ASME B 16.34	Test Report / FILM	3/2	2	1	Only for rating ANSI 900 and above. Applicable for Body and Bonnet only. For Lower rating only if called for in specification.
		4. Surface Quality	MA	1. Visual	100%	MSS-SP-55	MSS-SP-55	Test Certificate	3/2	---	2,1	
2. MT/PT	100%			ASME B 16.34	ASME B 16.34	Test Certificate	3	2	1	After Machining on machined surface only		

LEGEND: * CR - Critical characteristics
MA - Major characteristics
MI - Minor characteristics

RT- Radiographic Test
UT - Ultrasonic Test

PT - Dye penetrant Test
MT- Magnetic Test

\$ P - Agency Performing the Test.
W - Agency Witnessing the Test.
V - Agency Verifying the Test.

1 - BHEL
2 - Vendor
3 - Sub-vendor

4 - Customer / Customer TPIA



PEM :: C&I

**4X270 MW BHADRADRI QUALITY PLAN
FOR
CONTROL VALVE (PNEUMATIC)**

QUALITY PLAN NO.: PE-QP-411-145-I 006

VOLUME

SECTION

REV. NO.

01

DATE: 28.05.2015

SHEET

2

OF

7

Sl. No.	Component / operation	Characteristics Checked	* Category	Type/Method of Check	Extent of Check	Reference documents	Acceptance Norms	Format of Records	Agency \$			Remarks
									P	W	V	
		5. Pressure test for shell	MA	Hyd. Test	100%	ISA-S-75.19/ ASME B 16.34	ISA-S-75.19/ ASME B 16.34	Test Certificate	2	2	1	For Body & Bonnet after machining
1.2	Diaphragm	1. Surface Quality	MA	Visual	100%	Mfr. standard	Mfr. standard	Test Certificate	3/2	---	2,1	
		2. Hardness	MA	Measurement	100%	Mfr. standard	Mfr. standard	Test Certificate	3/2	---	2,1	
		3. Endurance / Life cycle	MA	Cyclic test 10,000 cycles	One / Type	10,000 cycles/ Mfr. standard.	No damage	Test Certificate	3/2		2,1	
1.3	Spring	1. Composition	MA	Chemical- Analysis	One sample/ Heat	Material spec. / Mfr. standard	Material spec. / Mfr. standard	Test Certificate	3	---	2,1	
		2. Mech. Properties	MA	Mech. Test	One sample/ Heat	Material spec. / Mfr. standard	Material spec. / Mfr. standard	Test Certificate	3	---	2,1	Mech. Test shall be as per IS Standard.
		3. Performance	MA	1. Stiffness ratio	100%	Material spec. / Mfr. standard	Material spec. / Mfr. standard	Test Certificate	3	---	2,1	
				2. Scragging	100%	Material spec. / Mfr. standard	Material spec. / Mfr. standard	Test Certificate	3	---	2,1	
				3. Cyclic test (Endurance)	One / type	10,000 cycles	Material spec. / Mfr. standard	Test Certificate	3	---	2,1	
4. Dimension (Measurement)	One sample/ Lot			Mfr. standard	Appd Drg	Record	3	---	2,1			

LEGEND: * CR - Critical characteristics
MA - Major characteristics
MI - Minor characteristics

RT- Radiographic Test
UT - Ultrasonic Test

PT - Dye penetrant Test
MT- Magnetic Test

\$ P - Agency Performing the Test.
W - Agency Witnessing the Test.
V - Agency Verifying the Test.

1 - BHEL
2 - Vendor
3 - Sub-vendor

4 - Customer /
Customer TPIA



PEM :: C&I

**4X270 MW BHADRADRI QUALITY PLAN
FOR
CONTROL VALVE (PNEUMATIC)**

QUALITY PLAN NO.: PE-QP-411-145-I 006

VOLUME

SECTION

REV. NO.

01

DATE: 28.05.2015

SHEET

3

OF

7

Sl. No.	Component / operation	Characteristics Checked	* Category	Type/Method of Check	Extent of Check	Reference documents	Acceptance Norms	Format of Records	Agency \$			Remarks
									P	W	V	
1.4	Electrical items [Limit switches, Solenoids, Position Transmitter(if provided externally)]	1. Routine Test	MA	HV, IR, Continuity function	100%	Rele. Standards	Rele. Standards	Test Certificate	3	---	2,1	In case TC is not available, Actual test shall be conducted
		2. Degree of protection	MA	IP/NEMA Tests	One sample / type	Approved Data sheet	Approved Data sheet	Test Certificate	3	---	2,1	
1.5	Pressure Gauges	1. Performance	MA	Review of calibration certificates	100%	Mfr. Standard	Mfr. Standard	Test Certificate	3	---	2,1	
		2. Marking	MA	Visual	100%	Mfr. standard	Mfr. standard	Records	3	---	2,1	
2.0	IN PROCESS INSPECTION											
2.1	After machining, i, Body ii Bonnet iii Plug iv Valve Stem v seat ring/cage	1. Surface flaws	MA	Visual & MT/PT	100% (on accessible surfaces)	ASME B 16.34	ASME B 16.34	Test Records	2	---	1	Butt weld ends shall be included.
		2. Dimensional checks	MA	Measurement	100%	Mfr. Standard	Mfr. Standard	Records	2	---	1	
		3. Hard facing (wherever applicable)	MA	Hardness Measurement	One sample/Lot	Mfr. Standard	Mfr. Standard	Records	2	---	1	
2.2	Lapping	Machining surface contact	MA	Blue Matching	One sample/lot	-----	Proper Physical Contact	---	2	---	---	

LEGEND: * CR - Critical characteristics
MA - Major characteristics
MI - Minor characteristics

RT- Radiographic Test
UT - Ultrasonic Test

PT - Dye penetrant Test
MT- Magnetic Test

\$ P - Agency Performing the Test.
W - Agency Witnessing the Test.
V - Agency Verifying the Test.

1 - BHEL
2 - Vendor
3 - Sub-vendor

4 - Customer / Customer TPIA



PEM :: C&I

**4X270 MW BHADRADRI QUALITY PLAN
FOR
CONTROL VALVE (PNEUMATIC)**

QUALITY PLAN NO.: PE-QP-411-145-I 006

VOLUME

SECTION

REV. NO.

01

DATE: 28.05.2015

SHEET

4

OF

7

Sl. No.	Component / operation	Characteristics Checked	* Category	Type/Method of Check	Extent of Check	Reference documents	Acceptance Norms	Format of Records	Agency \$			Remarks
									P	W	V	
3.0	TESTS ON COMPLETED VALVE											
3.1	Actuator Chamber	Leakage & Strength	MA	Pneumatic test	100%	Mfr. Standard	No Leakage	Test Certificate	2	1	1	Refer Note-4
3.2	Body	Leakage and Pressure test (Body Mount Leakage)	MA	Hydro test	100%	ISA - S-75.19	No Leakage	Test Certificate	2	1	1	Refer Note-4
3.3	Seat leakage test for completed valve	Seat Leakage	MA	Pneumatic Test	100%	FCI-70.2	FCI-70.2	Test Certificate	2	1	1, 4	Refer Note-4
4.0	OPERATION TEST ON COMPLETED VALVE (Final inspection)	1. Valve Travel	MA	Measurement	100%	Approved drg. / data sheet	Approved drg. / data sheet	Test Report	2	1	1, 4	Refer Note-4
		2. Opening/Closing time	MA	Measurement	100%	Approved drg. / data sheet	Approved drg. / data sheet	Test Report	2	1	1, 4	Refer Note-4
		3. Linearity/cam characteristic	MA	Measurement	100%	Approved drg. / data sheet	Approved drg. / data sheet	Test Report	2	1	1, 4	Refer Note-4
		4. Repeatability	MA	Measurement	100%	Approved drg. / data sheet	Approved drg. / data sheet	Test Report	2	1	1, 4	Refer Note-4
		5. Hysteresis	MA	Measurement	100%	Approved drg. / data sheet	Approved drg. / data sheet	Test Report	2	1	1, 4	Refer Note-4
		6. Sensitivity	MA	Measurement	100%	Approved drg. / data sheet	Approved drg. / data sheet	Test Report	2	1	1, 4	Refer Note-4
		7. Accuracy (Overall)	MA	Measurement	100%	Approved drg. / data sheet	Approved drg. / data sheet	Test Report	2	1	1, 4	Refer Note-4
		8. Control Valve characteristics / CV Test	MA	◆ Measurement (Press. vs. discharge and discharge vs. opening 0-100% in steps of 10%)	One per type	As per specs/ Approved drg. / data sheet	As per specs/ Approved drg. / data sheet	Test Certificate	2	1, 4	4	◆ Size = Body & port size Or Body size & CV for non std port. Refer Note 1.
LEGEND: * CR - Critical characteristics RT- Radiographic Test PT – Dye penetrant Test \$ P - Agency Performing the Test. 1 - BHEL 4 – Customer / Customer TPIA MA - Major characteristics UT – Ultrasonic Test MT- Magnetic Test W - Agency Witnessing the Test. 2 - Vendor MI - Minor characteristics V - Agency Verifying the Test. 3 - Sub-vendor												



PEM :: C&I

**4X270 MW BHADRADRI QUALITY PLAN
FOR
CONTROL VALVE (PNEUMATIC)**

QUALITY PLAN NO.: PE-QP-411-145-I 006

VOLUME

SECTION

REV. NO.

01

DATE: 28.05.2015

SHEET

5

OF

7

Sl. No.	Component / operation	Characteristics Checked	* Category	Type/Method of Check	Extent of Check	Reference documents	Acceptance Norms	Format of Records	Agency \$			Remarks
									P	W	V	
		9. Operation of limit switch & solenoids and other accessories	MA	Function	100%	Approved drg. / data sheet	As per specs/ Approved drg. / data sheet	Test Report	2	1	1, 4	On assembled valve Refer Note-4
		10. Overall dimensions	MI	Visual and dimensional	100%	Approved drg. / data sheet	As per specs/ Approved drg. / data sheet	Records	2	1	1, 4	Refer Note-4
		11. Pre defined valve position in case of air failure	MA	Visual	100%	As per spec & Appd drg	As per spec & Appd drg	Test Certificate	2	1	1, 4	
		12. Cleanliness, painting, stamping (for direction of flow), Tag No.	MA	Visual and dimensional	100%	Approved drg. / data sheet	As per specs/ Approved drg. / data sheet	Test Certificate	2	1	1	
5.0	AUXILIARY ITEMS (Performance test of auxiliary items shall be performed on the completely assembled valve)											
5.1	Positioner	Overall leakage after assembly including Nozzles leakage	MA	Leak Test (in the steady state input signal)	100 %	Mfr. Standard	No leakage	Test Certificate	3/2	---	1	Overall leakage including tubing
5.2	Air filter regulator	1. Normal air consumption	MA	Measurement	Each type	Mfr. Standard	No leakage	Test Certificate	3/2	---	1	
		2. Overall leakage	MA	Visual (soap solution)	100 %	Mfr. Standard	No leakage	Test Certificate	3/2	---	1	
5.3	Air lock relay	Performance Test	MA	Leakage test	100%	Mfr. Standard	No leakage	Test Certificate	3/2	---	1	
5.4	Electronic position transmitter(not applicable if provided integral to smart positioner)	1. Accuracy	MA	Operation	100%	Approved data sheet /	Approved data sheet /	Test Certificate	2	1	1	

LEGEND: * CR - Critical characteristics
MA - Major characteristics
MI - Minor characteristics

RT- Radiographic Test
UT - Ultrasonic Test

PT - Dye penetrant Test
MT- Magnetic Test

\$ P - Agency Performing the Test.
W - Agency Witnessing the Test.
V - Agency Verifying the Test.

1 - BHEL
2 - Vendor
3 - Sub-vendor

4 - Customer /
Customer TPIA



PEM :: C&I

**4X270 MW BHADRADRI QUALITY PLAN
FOR
CONTROL VALVE (PNEUMATIC)**

QUALITY PLAN NO.: PE-QP-411-145-I 006

VOLUME

SECTION

REV. NO.

01

DATE: 28.05.2015

SHEET

6

OF

7

Sl. No.	Component / operation	Characteristics Checked	* Category	Type/Method of Check	Extent of Check	Reference documents	Acceptance Norms	Format of Records	Agency \$			Remarks
									P	W	V	
5.5	Current to Pneumatic converter(not applicable for smart positioner)	1. Physical Verification Make/Model	MA	Visual	100%	Approved drg. / data sheet	Approved drg. / data sheet	Test Certificate	2	---	2,1	
		2. Degree of Protection	MA	IP/NEMA test	Each type	Relevant Standard	Relevant Standard	Test Certificate	3	---	2,1	
		3. Linearity	CR	Measurement	100%	Approved drg. / data sheet / BHEL specn.	Approved drg. / data sheet / BHEL specn.	Inspection Report	2	---	1	
		4. Hysterisis	CR	Measurement	100%	Approved drg. / data sheet / BHEL specn.	Approved drg. / data sheet / BHEL specn.	Inspection Report	2	---	1	
5.6	Smart Positioner (As Applicable)	1. Physical Verification Make/Model	MA	Visual	100%	Approved drg. / data sheet	Approved drg. / data sheet	Test Certificate	2	---	2,1	
		2. Degree of Protection	MA	IP/NEMA test	Each type	Relevant Standard	Relevant Standard	Test Certificate	3	---	2,1	
		3. Linearity	CR	Measurement	100%	Approved drg. / data sheet / BHEL specn.	Approved drg. / data sheet / BHEL specn.	Inspection Report	2	---	1	
		4. Hysterisis	CR	Measurement	100%	Approved drg. / data sheet / BHEL specn.	Approved drg. / data sheet / BHEL specn.	Inspection Report	2	---	1	
		5. Calibration with Hand Held Communicator	MA	Measurement	Each type	Approved data sheet / Mfr. Standard	Approved data sheet / Mfr. Standard	Test Certificate	2	1	1	
6.0	PAINTING	Soundness of Painting	MA	Visual and Measurement	100%	BHEL specn. / Mfr. Standard	BHEL specn. / Mfr. Standard	Inspection Report	2	---	---	Refer Note-2

LEGEND: * CR - Critical characteristics
MA - Major characteristics
MI - Minor characteristics

RT- Radiographic Test
UT - Ultrasonic Test

PT - Dye penetrant Test
MT- Magnetic Test

\$ P - Agency Performing the Test.
W - Agency Witnessing the Test.
V - Agency Verifying the Test.

1 - BHEL
2 - Vendor
3 - Sub-vendor

4 - Customer / Customer TPIA

 PEM :: C&I	4X270 MW BHADRADRI QUALITY PLAN FOR CONTROL VALVE (PNEUMATIC)							QUALITY PLAN NO.: PE-QP-411-145-I 006				
								VOLUME				
								SECTION				
								REV. NO. 00		DATE: 28.05.2015		
SHEET 7		OF 7										
Sl. No.	Component / operation	Characteristics Checked	* Category	Type/Method of Check	Extent of Check	Reference documents	Acceptance Norms	Format of Records	Agency \$			Remarks
									P	W	V	
7.0	PACKING	Soundness of Packing against transit damage	MA	Visual	100%	Mfr. Standard	Mfr. Standard	Inspection Report	2	---	---	Refer Note-3

NOTES:

1. In case ~~valid CV test certificate for a similar control valve(Same type, Same size, Same CV) is not submitted to BHEL by the vendor~~, CV test shall be conducted at FCRI/Any govt. approved laboratory/ BHEL approved Laboratory.
2. In the absence of BHEL spec. for painting, vendor to obtain BHEL's approval on their painting specification / procedure.
3. Sea worthy packing shall be provided, if applicable.
4. The quantum of check shall be 100% for manufacturer and 10% for BHEL/BHEL nominated inspection agency.
5. IBR certificates in Form III-C shall be submitted if called for in the specification/datasheet.
6. Copies of all TC's(Test Certificates) for materials duly correlated with Heat Nos., TC's for electrical items and mechanical tests(Leak/Operation) shall be submitted to BHEL for verification and acceptance.

LEGEND: * CR - Critical characteristics MA - Major characteristics MI - Minor characteristics	RT- Radiographic Test UT - Ultrasonic Test	PT - Dye penetrant Test MT- Magnetic Test	\$ P - Agency Performing the Test. W - Agency Witnessing the Test. V - Agency Verifying the Test.	1 - BHEL 2 - Vendor 3 - Sub-vendor	4 - Customer / Customer TPIA
---	---	--	---	--	---------------------------------



**STANDARD QUALITY
PLAN FOR AUXILIARY
STEAM PRDS**

CUSTOMER : TSGENCO

PROJECT: 4X270 MW
BHADRADRI TPS

SPECIFICATION
NUMBR PE-TS-411-142-N101

BIDDER/ : AS PER APPROVED
VENDOR LIST

SPECIFICATION TITLE :
AUXILIARY STEAM P.R.D.S

SHEET 1 of 2

SYSTEM ITEM :
STEAM DESUPERHEATER

QUALITY PLAN
NUMBR

SECTION VOLUME

SL. NO.	COMPONENT/ OPERATION	CHARACT-ERISTIC CHECK	CAT.	TYPE METHOD OF CHECK	EXTENT OF CHECK	REFERENCE DOCUMENT	ACCEPTANCE NORM	FORMAT OF RECORD	AGENCY			REMARKS
									P	W	V	
1	2	3	4	5	6	7	8	9	10			11

1.0	Raw Materials											
1.1	Pipes	Mechanical & Chemical Prop.		Mechanical & Chemical	100%	Appd Specn./ Data Sheet/Drg.	Appd Specn./ Data Sheet/Drg.	TC	3/2	-	1	Correlation required
		Leakproofness		Hydraulic test	100%	-do-	-do-	TC	3/2	-	1	
		Dimensions		Measurement	100%	-do-	-do-	IR	3/2	-	1	
1.2	Forging	Physical & Chemical Prop.		Physical & Chemical Prop.	1/heat	Appd Specn./ Data Sheet/Drg.	Appd Specn./ Data Sheet/Drg.	TC	3/2	-	1	Correlation required
		Dimensions		Measurement	100%	-do-	-do-	IR	3/2	-	1	
		Heat Treatment		Scrutiny	100%	-do-	-do-	HT/SR Chart	3/2	-	1	Correlation required
2.0	In Process											
2.1	Forgings	Internal defects		U.T	100%	ASTMA 435	ASTMA 435	IR	3/2	-	1	
2.2	Machining Body Internals	Dimensions		Measurement	100%	Appd.Drg.	Appd.Drg.	IR	3/2	-	1	Correlation required
2.3	Body	Surface Defects		D.P. Check	100%	ASTME165	ASME-B 16.34 ,Appendix-III	TC	3/2	-	1	

PARTICULARS	CUSTOMER/CONSULTANT	BHEL	BIDDER / VENDOR
NAME			
SIGNATURE			
DATE			BIDDER'S/ VENDOR'S COMPANY SEALS



TITLE

EQUIPMENT SPECIFICATIONS

**AUXILIARY STEAM PRESSURE REDUCING
& DESUPERHEATING STATION**

4X270 MW BHADRADRI TPS

SPEC. NO.: PE-TS-411-142-N101

VOLUME **II-B**

SECTION **D**

REV NO. **00** DATE 13.07.2015

SHEET 1 OF 1

TENDER DRAWINGS

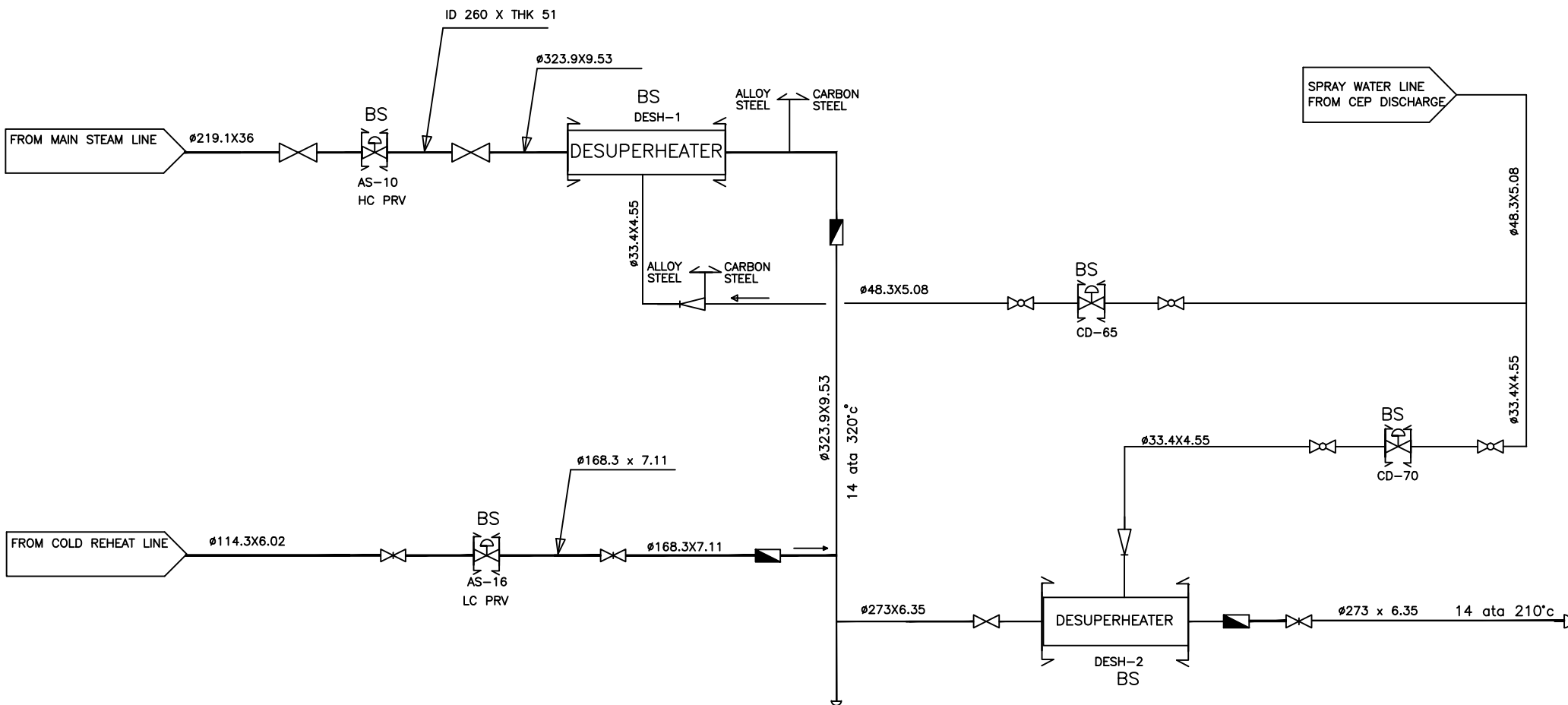

NOTE

1. EQUIPMENTS IN BIDDER'S SCOPE HAVE BEEN MARKED AS



The information on this document is the property of BHARAT HEAVY ELECTRICALS LIMITED. It must not be used for any other project without the written permission of the company.

JOB NO. 411		TELANGANA STATE POWER GENERATION CO. LTD.	
STATUS CONTRACT		4 X 270 MW BHADRADRI TPS	
DISTRIBUTION		BHARAT HEAVY ELECTRICALS LTD. DEPT. NAME SIGN DATE	
NO.		CODEDRN PKS	
NO.		CHD CM	
NO.		APPD RKG	
TITLE		AUXILIARY PR. REDUCING AND DESUPERHEATING STATION	
C&I PE		DEPT SCALE DRAWING NO.	
SIGN		PE-DG-411-148-N101	
DATE		SHEET 01 OF 01 REV. 00	

**TELANGANA STATE POWER GENERATION
CO. LTD**

4X270 MW BHADRADRI TPS

TECHNICAL SPECIFICATION
FOR
**AUXILIARY STEAM PRESSURE REDUCING
AND DESUPERHEATING STATION
ALONGWITH ACCESSORIES**

VOLUME - III

SPECIFICATION No: **PE-TS -411-142-N101 (REV 00)**



BHARAT HEAVY ELECTRICALS LIMITED
POWER SECTOR
PROJECT ENGINEERING MANAGEMENT
PPEI, NOIDA, INDIA



TITLE

PREAMBLE

SPECIFICATION NO **PE-SS-999-100-Q-001**

VOLUME **III**

SECTION **PREAMBLE**

REV NO. **0** DATE

SHEET **1 OF 1**

VOLUME – III TECHNICAL SCHEDULES

1.0 This volume contains technical schedules and Data Sheets – B , which are to be duly filled by the bidder and the same shall be furnished with the technical bid as per instructions given in Document No. PES-100-901 in Volume-III.

2.0 The requirements mentioned in Section – C / Data Sheets – A of Section – D shall prevail and govern in case of conflict between the same and the corresponding requirements mentioned in the descriptive portion in Section – D.



TITLE

**AUXILIARY STEAM PRESSURE REDUCING
& DESUPERHEATING STATION**

SPEC. NO.: PE-TS-411-142-N101

VOLUME **III**

SECTION **CONTENTS**

REV NO. **0** DATE 13.07.2015

SHEET 1 OF 3

- 1.0 Volume III comprises of following: -
1.1 Data Sheet : Data Sheet(s) 'B' Section 'D'.
1.2 Schedules :
PART – A : Technical Schedules
PART – B : Price Schedules
(See clause 2 (b) below for unpriced schedules)

The Schedule and Data Sheets enclosed/indexed shall be completely filled up by the bidder and furnished with the bid duly signed and stamped by the bidder. Purchaser reserves the right to ask the bidder to fill additional schedules, which are not listed in the contents.

- 2.0 Form No. PEM-6020 is a 'Checklist', which is enclosed to facilitate the bidder to make sure that the necessary data/information is furnished by him in his bid. The remarks column of this schedule shall be filled up by the bidder as per the instructions given below:-

- a) The bidder shall write 'Not Applicable' against those schedules / documents which are not listed in the contents.
- b) The bidder shall write 'Enclosed' for the listed schedules / documents which are filled and furnished by the bidder with the bid. Otherwise 'Not Enclosed' shall be written.
- c) Duly filled Part-A schedules as well as Data Sheet-B shall be furnished with the technical offer while Part-B (Price Schedules) shall be submitted with price offer in separate covers.
- d) Wherever unpriced schedules are to be furnished with Part-A schedules in tech. bids. the same is indicated in the filling space of price schedule formats.
- e) Other documents / information as required in the checklist shall also be furnished by the bidder.

- 3.0 The Data Sheet(s)-B shall be filled-up completely and typed written and shall be duly signed with Rev. No. and date. One copy of the same shall be furnished with the bid. The items, which deviate from the specification, shall be marked with an asterisk (*) in the data sheets and details shall also be given in the 'Schedule of deviations' from technical specification (Form No. PEM-6036).

- 4.0 Bidder shall fill specification No. in all schedules .

- 5.0 Schedules PEM – 6020 & PEM 6040 duly filled in shall be enclosed by bidder both in Technical and price offers.



TITLE

**AUXILIARY STEAM PRESSURE REDUCING
& DESUPERHEATING STATION**

SPEC. NO.: PE-TS-411-142-N101

VOLUME **III**SECTION **CONTENTS**REV NO. **0** DATE 13.07.2015

SHEET 2 OF 3

CONTENTS**PART-A**

<u>SL.NO.</u>	<u>FORM NO.</u>	<u>FORM DESCRIPTION</u>	<u>NO. OF SHEETS</u>
1.		Data Sheet-C for Control Valves	3
2.		Data Sheet-C for Steam Desuperheater	2
3.	PEM-6020-2	Check List - List of Schedules	1
4.	PEM-6024	Schedule of Drawings / Catalogues submitted with bid	1
5.	PEM-6026*	Schedule of Equipment, Manufacture, Dispatch & Shipment to Site	1
6.	PEM-6027*	Schedule of Weights & Dimensions	1
7.	PEM-6030*	Inspection Schedule	1
8.	PEM-6036	Schedule of Deviations	1
9.	PEM-6040	Schedule of Declaration	1
10.	PEM-6041*	Quality Plan	1
11.	PEM-6041-0	Instructions for filling up the Quality Plan	1
12.	PEM-6042*	Vendor's Drawings / Document Schedule	1
13.	PEM-6046-1*	Inspection Request	1

* To be filled up by successful bidder after LOI.



TITLE

**AUXILIARY STEAM PRESSURE REDUCING
& DESUPERHEATING STATION**

SPEC. NO.: PE-TS-411-142-N101

VOLUME **III**SECTION **CONTENTS**REV NO. **0** DATE 13.07.2015

SHEET 3 OF 3

CONTENTS**PART-B**

<u>SL.NO.</u>	<u>FORM NO.</u>	<u>FORM DESCRIPTION</u>	<u>NO. OF SHEETS</u>
1.	PEM-6051	Schedule of Prices	1
2.	PEM-6052	Schedule of Unit Prices	2
3.	PEM-6053	Schedules of Prices for Commissioning & Mandatory Spares	1
4.	PEM-6054	Schedule of Prices for Recommended Spares	1
5.	PEM-6055	Schedule of Prices for Erection & Maintenance Tools & Tackles	1
6.	PEM-6056*	Schedule of Bidder's Man-power for Supervision of E & C and their Charges	1

* to be filled up by successful bidder after LOI.



TITLE

**AUXILIARY STEAM PRESSURE REDUCING
& DESUPERHEATING STATION**

SPEC. NO.: PE-TS-411-142-N101

VOLUME **III**

SECTION **PART-A**

REV NO. **00** DATE 13.07.2015

SHEET 1 OF 1

**VOLUME-III
PART-A**

SCHEDULES AND DATA SHEETS



TITLE

EQUIPMENT SPECIFICATIONS

**AUXILIARY STEAM PRESSURE REDUCING
& DESUPERHEATING STATION**

SPEC. NO.: PE-TS-411-142-N101

VOLUME **III**

SECTION **D**

REV NO. **0**

DATE 13.07.2015

SHEET 1 OF 1

DATA SHEETS - C
AUXILIARY STEAM PRESSURE REDUCING
& DESUPERHEATING STATION

(TO BE FILLED BY SUCCESSFUL VENDOR AFTER THE AWARD OF CONTRACT)

	Technical specification for APRDS CONTROL VALVES (Pneumatically Operated) 4x270 MW BHADRADRI TPS	SPECIFICATION NO. PE-TS-411-142-N101	
		VOLUME III	
		SECTION D	
		REV. NO. 00	DATE: 13.07.2015
		SHEET 1 of 3	

		NAME
		SIGNATURE
		DATE
Tag No.....	Quantity.....	Data Sheet No. PES-145-06-DS2-0

DATA SHEET C
DATA SHEET – C FOR CONTROL VALVE (WITH PNEUMATIC ACTUATOR)
 (TO BE FILLED BY THE BIDDER AFTER THE AWARD OF CONTRACT)

GENERAL*	PROJECT	
	SERVICE	
	LOCATION	
	DUTY	
	PIPE SIZE (inlet / outlet)	
	PIPE MATERIAL (inlet / outlet)	
BODY	MODEL NUMBER	
	TYPE OF BODY : GUIDING : NO. OF PORTS	
	BODY SIZE : PORT SIZE : DESIGN DV	
	END CONNECTION & RATING (ANSI)	
	BODY MATERIAL	
	PACKING MATERIAL SINGLE / DOUBLE	
	BONNET TYPE	
	TRIM FORM	
	TRIM MATERIAL : SEAT PLUG	
	TRIM MATERIAL : CAGE GUIDE	
	FLOW	
	OUTLET VELOCITY	
	REQUIRED LEAKAGE CLASS	
	NOISE LEVEL (dBA) (Spec. 3.1.14)	
VACUUM SERVICE		
ANTI CAVITATION TRIM		
PNEUMATIC ACTUATOR	MODEL NO. & SIZE	
	CLOSE AT : OPEN AT (Kg / Cm ² g)	
	*TRAVEL TIME FOR OPEN TO CLOSE, CLOSE TO OPEN	
	*VALVE POSN. ON SIGNAL AIR FAILURE	
	*VALVE POSN. ON SUPPLY AIR FAILURE	
ACCESSORIES	POSITIONER	
	AIR FILTER REGULATOR	
	AIR LOCK RELAY	
	POSITION LIMIT SWITCH	
	POSITION TRANSMITTER	
	SOLENOID VALVE	
	E / P CONVERTER	
	JUNCTION BOX	
	HAND WHEEL (SIDE MOUNTED)	
	LOCAL POSITION INDICATOR	
ELECTRO PNEUMATIC POSITIONER		

	Technical specification for APRDS CONTROL VALVES (Pneumatically Operated) 4x270 MW BHADRADRI TPS	SPECIFICATION NO. PE-TS-411-142-N101	
		VOLUME III	
		SECTION D	
		REV. NO. 00	DATE: 13.07.2015
		SHEET 2 of 3	

Tag No.....		Quantity.....		Data Sheet No. PES-145-06-DS2-0					
DATA SHEET C									
DATA SHEET – C FOR CONTROL VALVE (WITH PNEUMATIC ACTUATOR) (TO BE FILLED BY THE BIDDER AFTER THE AWARD OF CONTRACT)									
PERFORMANCE OF VALVE	LINEARITY								
	HYTERSIS								
	SENSITIVITY								
	ACCURACY								
SERVICE CONDITION*	SL.+ NO.	LOAD	FLOW (T/HR)	INLET PR. (KG/CM² (A))	OUTLET PR. (KG/CM² (A))	TEMP DEG. C	CALCULATED CV	% VALVE LIFT	VALVE O/L VELOCITY
VALVE TYPE									
* MAX SHUT OFF PRESS ((KG/CM ² g)									
* BODY DESIGN : PRESS ((KG/CM ² g) TEMP (DEG. C)									
* IBR FORM III-C									
TOTAL WEIGHT (VALVE + ACTUATOR + ACCESSORIES) KG.									

	Technical specification for Control Valves with Accessories (Pneumatically Operated) 4x270 MW BHADRADRI TPS	SPEC NO.: PE-TS-411-142-N101	
	VOLUME III		
	SECTION D		
	REV. NO. 00	DATE: 13.07.2015	
	SHEET OF		

Tag No..... Quantity..... Data Sheet No. PES-145-06-DS2-1

DATA SHEET C

**DATA SHEET – C FOR CONTROL VALVE (WITH PNEUMATIC ACTUATOR)
(TO BE FILLED BY THE BIDDER AFTER THE AWARD OF CONTRACT)**

POSITIONER (SMART) WITH HART PROTOCOL	MFR. & MODEL NUMBER		
	BYPASS	GAUGES	ENCL. CLASS
	INPUT SIGNAL (Kg / Cm ²)		
	OUTPUT SIGNAL (Kg / Cm ²)		
AIR FILTER REGULATOR TWO (2) Nos. PER CV	MFR. & MODEL NUMBER		
	AIR SUPPLY PRESS (Kg / Cm ² g)		
	OUTPUT PRESS (Kg / Cm ² g)		
	OUTPUT GAUGE FILTER SIZE		
AIR LOCK	MFR. & MODEL NUMBER		
	SET PRESS (Kg / Cm ²)		
	SUPPLY PRESS (Kg / Cm ²)		
	RESET TYPE		
	VENT PLUG		
LIMIT SWITCH	MFR. & MODEL NUMBER		
	OPEN posn	INT posn	CLOSE posn
	CONTACT TYPE		
	RATING (AC / DC)		
	ENCLOSURE CLASS		
POSITION TRANSMITTER (PART OF POSITIONER)	MFR. & MODEL NUMBER		
	TYPE		
	SUPPLY		
	OUTPUT RATING		
	ACCURACY		
	ENCLOSURE CLASS		
SOLENOID VALVE	MFR. & MODEL NUMBER		
	RATING		
	OPERATION	QUANTITY	
	COIL INSULATION CLASS		
	ENCLOSURE CLASS		
HANDWHEEL	ORIENTATION		
JUNCTION BOX	NO. OF WAYS		
	SIZE		
	CABLE GLANDS (Size / Quantity)		
	ENCLOSURE CLASS		
I/P CONVERTER (PART OF POSITIONER)	INPUT SIGNAL	POWER SUPPLY	
	SPLIT RANGE		
	ENCLOSURE CLASS		
	LINEARITY		
	HYSTERISIS		
Cu. Tubing & Fittings / per CV	15 Meters of ¼ " PVC coated Cu. Tubing, with 1 set of Fittings for connection to IA Header on one end and accessories on another end of CV		
			COMPANY SEAL
			NAME
			SIGNATURE
			DATE



TITLE **DATASHEET-C**
STEAM DESUPERHEATER

SPEC. NO.: PE-TS-411-142-N101

VOLUME III PART -A

SHEET 1 OF 2

INSTRUCTIONS TO BIDDER

1. This data sheet shall be read in conjunction with specification No. PES - 148 - 01 Section - D, Volume - II B.
2. Items which deviate from specification shall be marked with an asterisk (*)
3. This data sheet shall be submitted alongwith bid.

SL.NO.	ITEM	UNIT	PARTICULARS
1.0	TYPE OF DESUPERHEATER	-	
2.0	MODEL NO.	-	
3.0	NUMBER OFFERED	NOS.	
4.0	FLOW CAPACITY (OUTLET OF DESUPERHEATER)	T/HR	
5.0	STEAM PARAMETERS AT INLET		
5.1	PRESSURE	KG/CM ² A	
5.2	TEMPERATURE	°C	
5.3	FLOW	T/HR	
6.0	STEAM PARAMETERS AT OUTLET		
6.1	PRESSURE	KG/CM ² A	
6.2	TEMPERATURE	°C	
7.0	SPRAY WATER PARAMETERS		
7.1	PRESSURE	KG/CM ² A	
7.2	QUANTITY	T/HR	
8.0	DESIGN PARAMETERS OF DESUPERHEATER BODY		
8.1	PRESSURE	KG/CM ² G	
8.2	TEMPERATURE	°C	
9.0	DESIGN PRESSURE OF SPRAY NOZZLE	KG/CM ² G	
10.0	TYPE OF SPRAY NOZZLE		
10.1	FIXED / VARIABLE AREA ORIFICE		
10.2	SINGLE HOLE / MULTI HOLE		

Name of Bidder / Vendor

Project

Revision Number

0

1

2

3

Signature of Bidder / Vendor /
Authorised Representative

Date

BIDDER'S SEAL



TITLE
DATA SHEET - C
STEAM DESUPERHEATER

SPECIFICATION NO. PE-TS-411-142-N101

VOLUME III PART -A

SHEET 2 OF 2

INSTRUCTIONS TO BIDDER

1. This data sheet shall be read in conjunction with specification No. PES - 148 - 01 Section - D, Volume - II B.
2. Items which deviate from specification shall be marked with an asterisk (*)
3. This data sheet shall be submitted alongwith bid.

SL.NO.	ITEM	UNIT	PARTICULARS
11.0	NUMBER OF SPRAY NOZZLE / TURNDOWN RATIO		
12.0	SPRAY WATER NOZZLE CHARACTERISTICS		
13.0	SIZE OF ORIFICE	MM	
14.0	MIN. VELOCITY ACCEPTABLE IN THE DESUPERHEATER PIPE	M/SEC	
15.0	END CONNECTIONS TYPE & SIZE		
15.1	DESUPERHEATER INLET / OUTLET		
15.2	SPRAY WATER INLET		
16.0	MATERIAL OF CONSTRUCTION		
16.1	BODY		
16.2	SPRAY NOZZLE		
17.0	OVERALL DIMENSIONS	MM	
18.0	WEIGHT OF DESUPERHEATER	KG	
19.0	MOUNTING RECOMMENDATIONS (IF ANY)		
20.0	DESIGN CODE		
21.0	HYDRAULIC TEST PRESSURE	KG/CM ² G	

Name of Bidder / Vendor

Project

Revision Number

0

1

2

3

Signature of Bidder / Vendor /
Authorised Representative

Date

BIDDER'S SEAL

CHECKLIST — LIST OF SCHEDULES

Sl. No.	Form No.	Description	Tick Applicable Forms
1.	PEM-6024	Schedule of Drawings / Catalogues submitted with Bid	✓
2.	PEM-6025@	Schedule of Occurance of Key Events of Delivery,Erection& Commissioning	
3.	PEM-6026	Schedule of Equipment Manufacture, Despatch and Shipment to Site.	✓
4.	PEM-6027	Schedule of Weights & Dimensions	✓
5.	PEM-6028@	Schedule of Performance Guarantee	
6.	PEM-6030	Inspection Schedule	✓
7.	PEM-6031	Schedule of Cement and Steel and Quarterly Cement Requirement	
8.	PEM-6032	Schedule of Quarterly Requirement of Reinforcing Bars and Structural Steel	
9.	PEM-6033@	Bill of Quantities (Civil Works)	
10.	PEM-6035	Schedule of Bidder's Proposed Construction / Site Fabrication Facilities.	
11.	PEM-6036	Schedule of Deviations	✓
12.	PEM-6040	Schedule of Declaration	✓
13.	PEM-6041	Quality Plan	✓
14.	PEM-6042	Vendor's Drawings / Documents Schedule	✓
15.	PEM-6043@	Schedule of Occurance of Key Events for Civil / Structural Works	
16.	PEM-6046	Inspection Request	✓
17.	PEM-6051	Schedule of Prices	✓
18.	PEM-6052@	Schedule of Unit Prices	✓
19.	PEM-6053	Schedule of Prices for Commissioning & Mandatory Spares	✓
20.	PEM-6054	Schedule of Prices for Recommended Spares	✓
21.	PEM-6055	Schedule Prices for Erection and Maintenance Tools & Tackles	✓
22.	PEM-6056	Schedule of Bidder's Man-power for Supervision of E & C and their Charges.	✓
23.	PEM-6057	Schedule of Daily & Overtime Rates	
24.	PEM-6058	Schedule of Hire-charges for Construction / Site Fabrication Facilities	
For Forms marked with @ certain information to be filled by DEs - before issuing to bidder.			



TITLE

**SCHEDULE OF DRAWINGS /
CATALOGUES SUBMITTED WITH BID**

SPECIFICATION NUMBER PE-TS-411-142-N101

VOLUME III PART - A

SHEET OF

Section C/D enclosed with the specification indicate the drawings / catalogues to be furnished with the bid. The bidder in addition to furnishing the same, can also include any other drawings / catalogues which he may desire to submit with the bid. This schedule duly lists out such drawings as enclosed by the bidder with the bid.

DRAWING / CATALOGUE NUMBER	DESCRIPTION	NUMBER OF SHEETS

PARTICULARS OF BIDDER / AUTHORISED REPRESENTATIVE

NAME	DESIGNATION	SIGNATURE	DATE	

COMPANY SEAL



TITLE

**SCHEDULE OF EQUIPMENT,
MANUFACTURE, DESPATCH AND
SHIPMENT TO SITE**

SPECIFICATION NUMBER PE-TS-411-142-N101

VOLUME III PART - A

SHEET OF

Equipment / Major Bought-out Items	Time for Manufacture/ Procurement from Date of Issue of Letter of Intent (Weeks)	Time for Test, Dismantling Packing & Ready for Despatch (Weeks)	Time required for Shipment to Site (Weeks)	Total Time from Date of Issue of Letter of Intent to Shipment to Site (Weeks)

We, the undersigned hereby undertake to meet the above time schedule in weeks for manufacture, despatch and shipment of each equipment and procurement of major boughtout items as listed above.

PARTICULARS OF BIDDER / AUTHORISED REPRESENTATIVE				
NAME	DESIGNATION	SIGNATURE	DATE	
				COMPANY SEAL



TITLE

**SCHEDULE OF
WEIGHTS & DIMENSIONS**

SPECIFICATION NUMBER PE-TS-411-142-N101

VOLUME III PART - A

SHEET OF

The bidder shall state below the weights and dimensions of various packages for shipment covering the complete scope.

Description of Package(s)	Dimensions (in meters)	Weight (in tonnes)

PARTICULARS OF BIDDER / AUTHORISED REPRESENTATIVE

NAME	DESIGNATION	SIGNATURE	DATE	COMPANY SEAL

		<h1>INSPECTION SCHEDULE</h1>		SPECIFICATION NUMBER PE-TS-411-142-N101		
				P.O. NUMBER		
				VOLUME - III PART-A	SHEET OF	
S. No.	ITEM / COMPONENT	PLACE & ADDRESS OF TEST / INSPECTION	Scheduled Date of Inspection	Duration of Test / Inspection (in days)		
<p>This schedule shall be in line with specification and quality plan requirements. The information in this form shall be furnished after receipt of LOI / PO.</p>						
PARTICULARS OF VENDOR' s / AUTHORISED REPRESENTATIVE						
NAME	SIGNATURE	DATE	COMPANY SEAL			



TITLE

*** SCHEDULE OF DEVIATIONS**

() From Conditions of Contract (Volume - I)

() From General Technical Conditions (Volume - II A)

() From Technical Specifications (Volume - II B)

SPECIFICATION NUMBER **PE-TS-411-142-N101**

VOLUME III PART - A

SHEET OF

* Each type of deviation shall be listed on a separate sheet. Tick the applicable

We the undersigned hereby certify that the above mentioned are the only deviations.

PARTICULARS OF BIDDER / AUTHORISED REPRESENTATIVE				
NAME	DESIGNATION	SIGNATURE	DATE	COMPANY SEAL



TITLE

*** SCHEDULE OF DECLARATION**

SPECIFICATION PE-TS-411-142-N101
NUMBER

VOLUME III PART - A

SHEET OF

DECLARATION

I,.....certify that all the technical data and information pertaining to this specification are correct and are true representation of the equipment/system covered by our formal proposal number Dated..... and there is no deviation to the specification.

I hereby certify that I am duly authorised representative of the Bidder's company whose name appears above my signature.

Bidders Company Name

Authorised representative's Signature

Name

Bidder's Intent The bidder hereby agrees to fully comply with the requirements and intent of this specifications for the price indicated.

* Bidder shall include this schedule both in technical and Price offers.

PARTICULARS OF BIDDER / AUTHORISED REPRESENTATIVE

NAME	DESIGNATION	SIGNATURE	DATE	COMPANY SEAL

	QUALITY PLAN		CUSTOMER: NTPC		PROJECT: 4X270 MW BHADRADRI TPS		SPECIFICATION: PE-TS-411-142-N101 NUMBER			
			BIDDER/ VENDOR		QUALITY PLAN NUMBER		SPECIFICATION TITLE: AUXILIARY STEAM P.R.D.S			
SHEET OF		SYSTEM:		ITEM:		SECTION		VOLUME III		
SL. NO.	COMPONENT/ OPERATION	CHARACTERISTIC CHECK	CAT. T	TYPE METHOD OF CHECK	EXTENT OF CHECK	REFERENCE DOCUMENT	ACCEPTANCE NORM	FORMAT OF RECORD	AGENCY	REMARKS
12		3	4	5	6	7	8	9	P W V	10 11

PARTICULARS BH	EL	BIDDER / VENDOR
NAME		
SIGNATURE		
DATE		BIDDER'S/ VENDOR'S COMPANY SEALS

INSTRUCTIONS FOR FILLING QUALITY PLAN

(Form No. PEM-6041-0)

The Quality Plan shall include all the Quality Control Measures and Checks adopted by the Vendor to ensure that the material/component/assembly/services supplied by him meet/will meet the requirements as per specifications and good practices. They shall include all stages of operation such as materials, processes, manufacture, assembly, packing and despatch. The following guide lines may be noted:

- Column 1- Serial Number
- Column 2- Component/Operation- The component and/or operation being checked shall be given here.
- Column 3- Characteristics check- The characteristics being checked shall be given here, e.g., chemical composition, mechanical properties, leak tightness, surface defects etc..
- Column 4- Category - 'CR' stands for critical characteristic - affecting safety of equipment and personnel
'MA' stands for major Characteristic - affecting safety of equipment and personnel
'MI' stands for minor characteristic - affecting appearance etc.
- Column 5- Type/Method of check e.g. chemical analysis tensile testing, hydraulic test, visual examination radiography etc.
- Column 6- Extent of check, such as, 100, 10, 1 per heat etc.
- Column 7- Reference Documents - Documents, such as technical specification, drawings, standard specifications (IS, BS ETC.) procedure, etc. according to which check is done.
- Column 8- Acceptance Norms - Standards etc. according to which acceptability or otherwise of the characteristics being checked is decided.
- Column 9- Format of Record - Formats, log sheets, reports, etc. in which the observations are recorded. Standard log sheets, reports, formats etc. of the Vendors shall be numbered and such reference numbers shall be included here.
- Column 10- Agency - The agency which performs the test/instruction shall be written in sub-column 'W'
The agency which verifies test certificates/inspection records and carries out audit check of the components/operation shall be written in sub-column 'V'
The agencies are codified '1' stands for (BHEL)
as 1,2 & 3 '1' * means the operation shall be cleared by BHEL before the start of the next operation.
'2' Stands for Vendor
'3' stands for sub-Vendor of the Vendor and so on.

Example :

- Entry '3' in column 'P' means test./inspection to be performed by sub-Vendor's QC
- Entry '2' in column 'W' means test./inspection to be witnessed by Vendor's QC
- Entry '1' in column 'V' means verification shall be done by BHEL and next stage to be started only after the hold point is cleared by BHEL
- Column II- Remarks - Any special remarks shall be given here.

NOTES :

1. In absence of correlation with the test certificate(s) (e.g. material identification) samples shall be drawn by BHEL and all tests as per relevant specifications shall be carried out in their presence or in recognized Government Laboratory.
2. When materials and components are initially identified and stamped by BHEL QS engineer, the identification marks shall be preserved till despatch. Wherever this is not possible, the identification mark shall be transferred to the components in the presence of BHEL QS Engineer unless otherwise agreed.
3. For castings and forgings integral test specimens shall be provided, When this is not possible for casting, they shall be poured in the presence of BHEL QS Engineer unless otherwise, if witnessing of test by BHEL is called for.
4. When welders qualified by reputed inspection agencies or statutory bodies are not available, qualification tests shall be conducted in the presence of BHEL QS Engineer.
5. This Quality Plan is liable to be modified as per the requirements of approved drawings and changes in technical specifications/drawings. If there are contradictions in respect of column 7 & 8 between this Quality Plan and the approved drawings specifications, the latter shall prevail.
6. Wherever inspection by BHELs Purchaser/Third Party/Statutory authorities are mandatory, this shall be compiled with.
7. Inspection reports, log sheets, test reports/certificate. etc. shall be furnished to BHEL at the appropriate stages or at the time of final inspection, as required.
8. This Quality Plan is also applicable to spares, if any, under scope of supply of Vendor.
9. The quality plan shall be submitted in septuplicate (7 Copies).



**VENDOR's
DRAWINGS/DOCUMENTS SCHEDULE
(Information in this form is to be furnished
only after receipt of LOI/IPO)**

SPEC. NO.: PE-TS-411-142-N101

VOLUME **III**

SECTION **PART-A**

REV NO. **0**

DATE

SHEET 1 OF 1

TITLE OF SPECIFICATION

.S. NO.	Vendor's Drawing/Document No. (VDN)	PEM's Drawing/Document No. (PDN)	First Submission Date
	TITLE Final		Approval Date
	VDN PDN		
	TITLE		
	VDN PDN		
	TITLE		
	VDN PDN		
	TITLE		
	VDN PDN		
	TITLE		
	VDN PDN		
	TITLE		
	VDN PDN		
	TITLE		
	VDN PDN		
	TITLE		

PARTICULARS OF VENDOR's/AUTHORISED REPRESENTATIVE

NAME	SIGNATURE	DATE	COMPANY SEAL

INSPECTION REQUEST
(From Vendor to BHEL Inspection Agency)

1 PROJECT TITLE:	
2 NAME OF VENDOR:	
3 BHEL'S LOI / PO NO:	DATE :
4 SYSTEM / ITEM DESCRIPTION	
5 ITEMS BEING OFFERED FOR INSPECTION WITH SL. NO. AS PER LOI / PO / BILLING SCHEDULE	
6 DESCRIPTION AND SL. NO. OF INSPECTION AS PER QUALITY PLAN	
7 QUANTITY OFFERED FOR INSPECTION	
8 PLACE OF INSPECTION (FULL ADDRESS AND NAME OF SUB-VENDOR, IF ANY)	
PLACE	
ADDRESS	
.....	
.....	
9 CONTACT PERSON (FOR SL. NO. 8 ABOVE).	
NAME DESIGNATION	
TELEPHONE FAX TELEGRAM	
TELEX	
10 THE FOLLOWING DOCUMENTS ARE APPROVED BY BHEL AND AVAILABLE AT PLACE OF INSPECTION	
(A) QUALITY PLAN (B) DRAWINGS (C) DATA SHEETS, CHARACTERISTIC CURVES ETC. (D) PLANT STANDARDS	
11 REQUIRED DATE OF INSPECTION LIKELY DURATION (No of Working days).....	
WEEKLY OFF DAY WORKING HOURS	
(At least 15 days prior notice shall be given by the Vendor to Inspection Agency)	
We hereby certify that the above items are complete in all respects and have been fully inspected/tested by us and are found to be as per technical specification/approved drawings/data sheets/characteristic curves and are acceptable to our QC department. The detailed inspection and test reports of our QC department are enclosed.	

VENDOR'S PARTICULARS					
NAME	DESIGNATION	SIGNATURE	PLACE	DATE	COMPANY SEAL



TITLE

**AUXILIARY STEAM PRESSURE REDUCING
& DESUPERHEATING STATION**

SPEC. NO.:PE-TS-411-142-N101

VOLUME **III**

SECTION **PART-B**

REV NO. **0** DATE 13.07.2015

SHEET **1** OF **1**

**VOLUME-III
PART-B
PRICE SCHEDULES**

	<p>TITLE</p> <p align="center">SCHEDULE OF PRICES AUXILIARY STEAM PRESSURE REDUCING & DESUPERHEATING STATION</p>	SPEC. NO.: PE-TS-411-142-N101	
		VOLUME III	
		SECTION PART-B	
		REV NO. 0	DATE 13.07.2015
		SHEET 1 OF 1	

S.No.	Description of Works or Equipment/System	Price (in Lakhs of Rs.)
1.0	Total price for design, manufacture, assembly, inspection, testing, packing and dispatch to site of auxiliary steam pressure reducing and desuperheating stations complete with High capacity PRV (AS-10), Low capacity PRV (AS-16), Spray control valves (CD-65 & CD-70), HT Desuperheater (DESH-1) & LT Desuperheater (DESH-2) and all accessories including commissioning spares and special tools & tackles as specified and necessary as per technical specification PE-TS-411-142-N101.	
2.0	Recommended spares, item-wise break up with item-wise price to be given as per "Schedule of Recommended Spares" enclosed under Vol. III of technical specification- price not to be included in clause 1.0 above, Bidder to indicate the break up.	
3.0	Mandatory Spares price – prices not to be included in clause 1.0 above	
4.0	Optional price of supervision of erection and commissioning of equipments – prices not to be included in clause 1.0 above.	
	Indicate all duties, taxes etc. Stating whether included/excluded in above price.	

-Bidder shall furnish this price schedule in his price offer only.

-.

PARTICULARS OF VENDOR'S/AUTHORISED REPRESENTATIVE	



TITLE
SCHEDULE OF UNIT PRICES
AUXILIARY STEAM PRESSURE REDUCING & DESUPERHEATING STATION

SPEC. NO.: PE-TS-411-142-N101

VOLUME **III**

SECTION **PART-B**

REV NO. **0** DATE 13.07.2015

SHEET 1 of 2

S.No.	Item Description	Unit Price (in Lakhs of Rs.)
1.0	Design, manufacture, inspection & testing, packing and delivery for site for following as specified in Technical specification PE-TS-411-142-N101:	
1.1	Unit Price of Control valves (4x270 MW Bhadradri TPS) <div style="border: 1px solid black; padding: 5px; margin-top: 10px;"> a) High Capacity Pr. Reducing Valve (AS-10) b) Low Capacity Pressure Reducing Valve (from CRH line) (AS-16) c) HC PRDS Control Spray Valve (CD-65) d) LC PRDS Control Spray Valve (CD-70) </div>	
1.2	Unit Price of Desuperheaters (4x270 MW Bhadradri TPS) <div style="border: 1px solid black; padding: 5px; margin-top: 10px;"> a) HT Desuperheater (DESH-1) b) LT Desuperheater (DESH-2) </div>	
1		



TITLE
SCHEDULE OF UNIT PRICES
**AUXILIARY STEAM PRESSURE REDUCING
 & DESUPERHEATING STATION**

SPEC. NO.: PE-TS-411-142-N101

VOLUME **III**

SECTION **PART-B**

REV NO. **0** DATE 13.07.2015

SHEET 2 OF 2

S.No.	Item Description	Unit Price (in Lakhs of Rs.)
1.3	Unit Price of Mandatory Spares [4x270 MW Bhadradi TPS]	
	High Capacity PRDS System (i.e for AS-10)	
1.3.1	a) Stem	1 no.
	b) Body seat rings	2 nos. for each type, size and rating of valves
	c) Gland packings	3 nos. for each type, size and rating of valves
	d) Gasket	3 nos.
	For Spray Water Line Control Valve (i.e. for CD-65,CD-70)	
1.3.2	a) Valve trim including cage, plug, stem, seat rings, guide bushings, stem packing	1 no. for each size, type & rating of valves
	Low Capacity PRDS System (i.e for AS-16)	
1.3.3	a) Stem	1 no.
	b) Body seat rings	2 nos. for each type, size and rating of valves
	c) Gland packings	3 nos. for each type, size and rating of valves
	d) Gasket	3 nos.



TITLE

*** SCHEDULE OF PRICES FOR
COMMISSIONING AND MANDATORY
SPARES**

SPECIFICATION PE-TS-411-142-N101
NUMBER

VOLUME III

SHEET OF

The bidder shall indicate here the quantity required for erection / commissioning and mandatory spares for equipment as listed in Section-C / Section - D. If the listed spares are not adequate, then the bidder shall indicate those and additional spares considered necessary by him.

Type	Manufacturer's Drawing No. / Part of spare	Description	Material	Quantity per Unit / Equipment	Quantity Required	If set, Nos. Per set	Delivery period (Weeks)	Unit Price (Rs.)	Total Price (Rs.)
Erection and Commissioning									
Mandatory Spares									
Additional Spares Mandatory Erection / Commissioning									

PARTICULARS OF BIDDER / AUTHORISED REPRESENTATIVE

NAME	DESIGNATION	SIGNATURE	DATE	COMPANY SEAL

* Unpriced schedule shall also be furnished along with Part-A Schedule in Technical Bid.



TITLE

**SCHEDULE OF PRICE FOR ERECTION
AND MAINTENANCE TOOLS & TACKLES**

SPECIFICATION NUMBER PE-TS-411-142-N101

VOLUME III

SHEET OF

The bidder shall be give below the list of erection and maintenance tools and tackles as offered by him. This shall also include the customer's list of maintenance tools, if specified in Section - C / Section - D.

S. No.	Description of Tools & Tackles	Quantity offered	Unit Price (Rs.)	Total Price (Rs.)

NOTE : The hire charges for vendor's equipment called for in this schedule shall include the cost of consumables, operation services, depreciation, wear and tear as well as vendor's over head and profit. (These rates will be payable by customer to the vendor, only if the customer's requires the use of this equipment for carrying out his own work out side the scope of this contract.)

PARTICULARS OF BIDDER / AUTHORISED REPRESENTATIVE				
NAME	DESIGNATION	SIGNATURE	DATE	
				COMPANY SEAL



TITLE

**SCHEDULE OF BIDDER'S MAN POWER
FOR SUPERVISION OF E & C
AND THEIR CHARGES**

SPECIFICATION NUMBER PE-TS-411-142-N101

VOLUME III

SHEET OF

The bidder shall indicate below, designation-wise, the personnel required for supervision of erection and commissioning and their charges.

SUPERVISION OF ERECTION

S. No.	Designation	Normal rate per day of 8 hours	Overtime rate per hour

SUPERVISION OF COMMISSIONING

Sl. No.	Designation	Normal rate per day of 8 hours	Overtime rate per hour

PARTICULARS OF BIDDER / AUTHORISED REPRESENTATIVE

				COMPANY SEAL
NAME	DESIGNATION	SIGNATURE	DATE	