

1X800MW KOTHAGUDEM, TPS, STAGE-VII, UNIT#12-TSGENCO

TECHNICAL SPECIFICATION FOR DEBRIS FILTER (DF).

Specification No. : PE-TS- 410-165-N001 (REV. 0)

VOLUME -IIB



**BHARAT HEAVY ELECTRICALS LIMITED
POWER SECTOR
PROJECT ENGINEERING MANAGEMENT
PPEI BLDG., SEC-16A, PLOT NO. 25
NOIDA – 201301 (UP)**

	TITLE : TECHNICAL SPECIFICATION FOR DEBRIS FILTER (DF) PREAMBLE	SPEC. NO. PE-TS- 410-165-N001	
		VOLUME : II B	
		REV. NO. 0	DATE :18.06.15
		SHEET 1	OF 2

1.0 The tender document contains three (3) volumes. The bidder shall meet the requirements of all the three volumes.

1.1 Volume -I CONDITIONS OF CONTRACT

This consists of four parts as below :

Volume - I A : This part contains instructions to bidders for making bids to BHEL.

Volume - I B : This part contains general commercial conditions of the tender and include provision that vendor shall be responsible for the quality of item supplied by their sub-vendors.

Volume - I C : This part contains special conditions of contract.

Volume - I D : This part contains commercial conditions for erection and commissioning site work, as applicable.

1.2 Volume - II TECHNICAL SPECIFICATIONS

Technical requirements are stipulated in Volume II which comprises of :

Volume - II A : General Technical Conditions

Volume - II B : Technical specification including drawings, if any

1.2.1 Volume - II B :

This volume is sub-divided into following sections:

Section - A : This section outlines the scope of enquiry.

Section - B : This section provides "Project Information"

Section - C : This section indicates technical requirements specific to the contract, not covered in Section-D.

Section - D : This section comprises of standard technical specifications of equipments complete with data sheet A, B & C.

Data sheet-A specifies data and other requirements pertaining to the equipment.

Data sheet - B specifies data to be filled by the bidder (Data Sheet B is contained in Volume - III)

Data sheet - C indicates data documents to be furnished after the award of contract as per agreed schedule by the vendor (as applicable).

	TITLE : TECHNICAL SPECIFICATION FOR DEBRIS FILTER (DF) PREAMBLE	SPEC. NO. PE-TS- 410-165-N001	
		VOLUME : II B	
		REV. NO. 0	DATE :18.06.15
		SHEET 2 OF 2	

1.2.2 **Volume - III TECHNICAL SCHEDULES**

- 1.0 This volume contains technical schedules and Data Sheets - B, which are to be duly filled by the bidder and the same shall be furnished with the technical bid as per instructions given in Document No.PES-100-901 in Volume-III.
- 2.0 The requirements mentioned in Section C/Data Sheets-A of Section-D shall prevail and govern in case of conflict between the same and the corresponding requirements mentioned in the descriptive portion in Section -D.



TITLE : TECHNICAL SPECIFICATION
FOR
DEBRIS FILTER (DF)

SPEC. NO. PE-TS-410-165-N001

VOLUME : II B

SECTION : A

REV. NO. 0

DATE : 18.06.2015

SHEET 1 of 1

INDEX

SECTION	TITLE
A	SCOPE OF ENQUIRY
B	PROJECT INFORMATION
C	SPECIFIC REQUIREMENTS
C1	SPECIFIC TECHNICAL REQUIREMENTS FOR DEBRIS FILTER .
C2	SPECIFIC TECHNICAL REQUIREMENTS (ELECTRICAL)
C3	SPECIFIC TECHNICAL REQUIREMENTS (C&I)
D	STANDARD TECH. SPECIFICATIONS
D1	DEBRIS FILTER
	◆ STANDARD TECHNICAL SPEC.NO. PE-TS-999-165-N001
	◆ DATA SHEET-A
	◆ DATA SHEET-C
	◆ QUALITY PLAN
D2	ELECTRICAL SYSTEMS
D3	CONTROL & INSTRUMENTATION SYSTEMS



TITLE : TECHNICAL SPECIFICATION
FOR
DEBRIS FILTER (DF)

SPEC. NO. PE-TS-410-165-N001

VOLUME : II B

SECTION : A

REV. NO. 0

DATE : 18.06.2015

SHEET 1 of 1

SECTION - A
SCOPE OF ENQUIRY



TITLE : TECHNICAL SPECIFICATION
FOR
DEBRIS FILTER (DF)

SPEC. NO. PE-TS-410-165-N001

VOLUME : II B

SECTION : A

REV. NO. 0

DATE : 18.06.15

SHEET 1 of 1

1.00.0 SCOPE

This enquiry covers the design, manufacture, assembly, inspection, testing at manufacturer's and/or his sub-contractors works properly packed for delivery of the items and installation checks, commissioning, trial runs & PG Testing at site as follows:

1.01.0 Debris Filters :

DEBRIS FILTER (DF) complete with all accessories as per the requirements specified in different sections of this specification for:

- **1X800MW KOTHAGUEM, TPS, STAGE-VII, UNIT#12**

The bidder's scope also includes installation checks, commissioning, trial runs & PG Testing at site of DF.

1.01.0 The bids shall be evaluated as per NIT.

2.00.00 GENERAL TECHNICAL INSTRUCTIONS:

2.01.00 It is not the intent to specify herein all the details of design and manufacture. However the equipment shall conform in all respects to high standard of design, engineering and workmanship, and shall be capable of performing the required duties in a manner acceptable to Engineer/ Owner, who will interpret the meaning of drawing and specifications, and shall be entitled to reject any component or material, which in his judgement is not in full accordance herewith.

2.02.00 The omission of specific reference to any component/ accessory necessary for the proper performance of the equipment's shall not relieve the bidder of the responsibility of providing such facilities to complete the supply of the equipment's at quoted prices.

2.03.00 In case of any deviation from this Technical specification (Vol. IIB) and General Technical Conditions (Vol. IIC), the same shall be indicated in the schedule of deviations enclosed in Volume-III, Part-A. In the absence of duly filled schedules it will be assumed that the bid strictly conforms to the specification.

2.04.00 BHEL's/ Customer's representatives shall be given full access to the shop in which the equipment's are being manufactured or tested and all test records shall be made available to him.

2.05.00 The equipment's covered under this specification shall not be despatched unless the same have been finally inspected, accepted and shipping release issued by BHEL/ Customer

2.06.00 Un-priced copy of price bid shall be furnished along with the technical bid.



**TITLE : TECHNICAL SPECIFICATION
FOR
DEBRIS FILTER (DF)**

SPEC. NO. PE-TS- 410-165-N001

VOLUME : II B

SECTION : C

REV. NO. 0

DATE : 18.06.2015

SHEET

1

of

1

SECTION - B

PROJECT INFORMATION

PROJECT SYNOPSIS AND GENERAL INFORMATION

CONTENT

CLAUSE NO.	DESCRIPTION
1.00.00	INTRODUCTION
2.00.00	APPROACH TO SITE
3.00.00	LAND
4.00.00	SOURCE OF COAL
5.00.00	SOURCE OF WATER
6.00.00	ASH DISPOSAL AREA
7.00.00	SALIENT DESIGN DATA

VOLUME : IIA

SECTION-II

PROJECT SYNOPSIS AND GENERAL INFORMATION

1.00.00 INTRODUCTION

The proposed 1x800 MW Kothagudem Thermal Power Station (KTPS), Stage-VII, Unit-12 would be set up by Telangana State Power Corporation Ltd. (TSGENCO) at Kothagudem, Telangana. The proposed Power Plant will be installed adjacent to the existing D colony of Kothagudem Thermal Power Station, at Kothagudem.

The Bidder shall acquaint himself by a visit to the site, if felt necessary, with the conditions prevailing at site before submission of the bid. The information given here in under is for general guidance and shall not be contractually binding on the Owner. All relevant site data /information as may be necessary shall have to be obtained /collected by the Bidder.

2.00.00 APPROACH TO SITE

Site is located in the existing D Colony of Kothagudem Thermal Power Station, which is at a distance 30 km from temple town of Bhadrachalam and 300 km from Hyderabad by road. The Nearest railway station is Bhadrachalam Road (Known as Kothagudem) at a distance of 12 km. Kothagudem- Bhadrachalam National Highway branches off to the power station site near village Paloncha.

3.00.00 LAND

Land is primarily required for the main plant & auxiliaries (BTG) and balance of plant (BOP) like ash handling, coal storage, cooling tower, switchyard etc., which is available within the existing plant boundary.

The existing colony is to be dismantled, and the land of about 137 acres will be used for the main plant building, water facilities, switchyard, coal handling etc. The raw water reservoir will be located adjacent to the existing raw water reservoirs.

230 acres of land required for Ash Dyke will be procured. Land is available for staff colony, which is to be constructed by the EPC contractor.

4.00.00 SOURCE OF COAL

100% Imported and Blended coal (50% imported + 50% indigenous) will be used. Indigenous coal shall be sourced from Suliyari coal mines, Madhya Pradesh.

5.00.00 **SOURCE OF WATER**

Source of water (total quantity of water is 2192 m³/hr) is Godavari River near Burgampahad & water will be pumped through existing GRP pipe line (of length approx. 26 km).

6.00.00 **ASH DISPOSAL AREA**

Ash shall be dumped in the ash dump area which will be about 9 km from plant. The ash dyke area of 230 acres is adequate for 1x800 MW unit as per MOEF norms.

7.00.00 **SALIENT DESIGN DATA**

7.01.00 Meteorological data of site is given below:-

Elevation above MSL	:	89 m
Monthly highest temperature	:	44.9 °C
Monthly lowest temperature.	:	12.9 °C
Rainfall		
	Average.:	1031 mm
	Max. :	100 mm/ hr
Mean Wind speed	:	5.8 kmph
Relative Humidity		
	Max :	82%
	Min :	35%
Seismic Zone	:	Zone-III as per IS- 1893 (Part-IV)

[Climatological data of Khammam is attached for reference].

ANNEXURE-II

TREATED WATER QUALITY

(DESIGN ANALYSIS OF CLARIFIED WATER)

[After addition of 50 ppm Alum, 20 ppm Lime ,1 ppm Polyelectrolyte and
5 ppm Chlorine on 100% purity basis)]

DESIGN ANALYSIS OF CLARIFIED WATER:

CONSTITUENTS	As	CONTENT	
Calcium	CaCO ₃	128.9	ppm
Magnesium	CaCO ₃	53.52	ppm
Sodium	CaCO ₃	73.44	ppm
Potassium	CaCO ₃	1.02	ppm
Iron in Soln.	Fe	0.1	ppm
Hydrogen (FMA)	CaCO ₃	-	ppm
TOTAL CATIONS (except iron)	CaCO ₃	256.88	ppm
Bicarbonate	CaCO ₃	143.4	ppm
Carbonate	CaCO ₃	0.53	ppm
Hydroxide	CaCO ₃	0.02	ppm
Sulphate	CaCO ₃	59.85	ppm
Chloride	CaCO ₃	50.82	ppm
Nitrate	CaCO ₃	1.21	ppm
Phosphate	CaCO ₃	-	ppm
Fluoride	CaCO ₃	1.05	ppm
TOTAL ANIONS	CaCO ₃	256.88	ppm
Reactive Silica	SiO ₂	10	ppm
Total Suspended Solid	CaCO ₃	10 ppm for normal condition	15 ppm (overload condition)
Conductivity at 25 deg C		450	Microsiemens/cm (max)
pH value at 25 ⁰ C	-	7.62	
Turbidity		Not to exceed 15	NTU (max) 10 NTU for normal condition



**TITLE : TECHNICAL SPECIFICATION
FOR
DEBRIS FILTER (DF)**

SPEC. NO. PE-TS- 410-165-N001

VOLUME : II B

SECTION : C

REV. NO. 0

DATE : 18.06.2015

SHEET

1

of

1

SECTION – C

SPECIFIC REQUIREMENTS

SECTION C1 : DEBRIS FILTER (MECHANICAL)

SECTION C2 : ELECTRICAL SYSTEMS

SECTION C3 : C&I SYSTEMS



**TITLE : TECHNICAL SPECIFICATION
FOR
DEBRIS FILTER (DF)**

SPEC. NO. PE-TS- 410-165-N001

VOLUME : II B

SECTION : C

REV. NO. 0

DATE : 18.06.2015

SHEET

1

of

1

**SECTION C1
DEBRIS FILTER
(MECHANICAL DETAILS)**

16 	TITLE : TECHNICAL SPECIFICATION	SPEC. NO: PE-TS- 410-165-N001	
	FOR	VOLUME : II B	
	DEBRIS FILTER(DF)	SECTION: C1	
		REV. NO. 0	DATE : 18.06.2015
		SHEET 1 OF 9	

1.0 GENERAL

The Debris Filter complete with all accessories shall conform to the standard technical specifications (Section-D) and Data Sheet-A enclosed herewith. In addition the requirements of this section shall also be complied with. However, wherever the details given in Section-D and Data Sheet-A are different, the requirements of Data Sheet-A shall prevail. Similarly in the event of contradictions between Section-C & Section-D/ Data Sheet-A, Section-C shall prevail.

Section C consists of 3 parts viz. Sec. C1, C2 and C3 for Mechanical, Electrical and C&I respectively, the requirements of all 3 sections shall be complied with.

2.0 DESCRIPTION OF EQUIPMENTS :

2.1 Debris Filter (DF) :

The Debris Filter where specified shall be installed on each CW inlet line to condenser to arrest floating matter and prevent clogging of Condenser Tubes. The condenser of each unit shall have two inlet CW lines, the debris filters shall be installed at upstream of COLTCS ball injection. The water analysis is attached as annexure-A with project information in section B. The debris discharge shall be connected at downstream of

3.0 SCOPE OF SUPPLY UNDER THE SPECIFICATION IN THE BIDDER'S SCOPE FOR DEBRIS FILTER.

3.1 The scope of supply for Debris Filter covered under this specification is as under.

The size, MOC's and other particulars of the equipments for projects are detailed in Data Sheet A annexed with Section – D of the specification.

SL.NO.	PROJECT	DEBRIS FILTER
1.	1X800MW KOTHAGUDEM, TPS, STAGE-VII, UNIT#12	2 SETS

16 	TITLE : TECHNICAL SPECIFICATION	SPEC. NO: PE-TS- 410-165-N001	
	FOR	VOLUME : II B	
	DEBRIS FILTER(DF)	SECTION: C1	
		REV. NO. 0	DATE : 18.06.2015
		SHEET 2 OF 9	

3.2 SCOPE OF SUPPLY OF DEBRIS FILTER INCLUDED IN THE BIDDER'S SCOPE :

3.2.1 Each set of Debris Filter (DF) shall comprise of following :

- a) Flushing pump with drive Motor (if required) - 1 No.
- b) Supply of complete interconnecting pipe (as applicable) and debris disposal pipe work including flanges/counter flanges, bends, fittings, supports, gaskets, fasteners etc. shall be in scope of Bidder. However bidder is to consider debris disposal pipe length and no. of bends as per the list of BOQ mentioned in Annexure-I to this Section. In case actual piping comes out to be less than the BOQ of Annexure-I, still bidder has to supply the same as minimum requirement. Bidder shall finalize the pipework to suit the layout at contract stage in such a way that no site welding is required for his pipework otherwise the same shall be carried out by bidder at site.
- c) Filter body/ housing Vent and drain connections along with their isolating valves.
- d) Length of Debris Filter, Scope of Counter Flange, Nuts and bolts shall be as per Annexure-I of section C1.
Thickness of body flange and counter flange shall be as per Drg no PE-DG-999-141-MO17 enclosed at enclosures at Annexure-III.
- e) Differential pressure measuring system for debris filters. DP measuring system shall comprise of 2 nos. DPT +1 no. DPG for each DF. Instrument shall be with *Remote seal* arrangement. Stubs for DPT and DPG shall be independent.
- f) Supporting arrangement complete with saddle support (as required as per layout), foundation plates, anchor bolts, nuts, sleeves, inserts, all installation materials, fixing bolts, clamps and other accessories etc. for complete equipment supplied under this package.
- g) Set of commissioning spares, on "As required basis".
- h) The Electrical & C&I items/ accessories as specified in succeeding clause/ respective sections herein.
- i) Starter Panel (Switch Gear Panel) shall be as follows:
 - a) 2 Sets of DF for each unit shall have one Common Starter Panel (Switch Gear Panel) for DCS based control system.

Switch Gear Panel should have suitable arrangement like Bus Coupler for

16 	TITLE : TECHNICAL SPECIFICATION	SPEC. NO: PE-TS- 410-165-N001	
	FOR	VOLUME : II B	
	DEBRIS FILTER(DF)	SECTION: C1	
		REV. NO. 0	DATE : 18.06.2015
		SHEET 3 OF 9	

providing redundancy to incoming supply feeder (1Working + 1 Standby feeder).

- j) Power and Control cables between Switchgear Panel and various drives is in bidder's scope of supply. . Location of Local Starter Panel may be considered 40m away from the drives and accordingly bidder to estimate cables in their scope.
- k) Control cables between field instruments and junction box / Switchgear panel.
- l) Set of mandatory spares as indicated in Data Sheet A .
- m) All the field instruments stipulated in this specification shall be in Bidder's scope.
- n) Finish paints for touch up painting of equipment after erection at site, in sealed containers.
- o) Set of special tools and tackles if required for maintenance and erection of the equipment supplied.
- p) Various drawings, data test reports/ certificates instruction manuals for erection operation and maintenance etc. as specified in Data Sheet-C. and cables schedule indicating BOQ for power & control cables.
- q) Panels & Instruments: Scope and Type as specified in C&I section wherever required.
- r) Provision for Cathodic Protection of DF.

Any item not specified but required to make DF a complete package shall also be in bidders scope.

4.0 SCOPE OF SERVICES INCLUDED IN THE BIDDER'S SCOPE :

The bidder's scope also includes following services at site, for scope under this specification for Debris Filter for respective projects

- a) Installation checks (Erection in BHEL's scope).
- b) Commissioning of equipment.
- c) Trial run for requisite period
- d) Performance Testing

The trial run of equipment shall be generally conducted immediately after

16 	TITLE : TECHNICAL SPECIFICATION	SPEC. NO: PE-TS- 410-165-N001	
	FOR	VOLUME : II B	
	DEBRIS FILTER(DF)	SECTION: C1	
		REV. NO. 0	DATE : 18.06.2015
		SHEET 4 OF 9	

commissioning while PG testing shall be conducted at a later date. These activities for different units shall be timed separately.

The no. of visits may be suitably assessed by bidders as per their experience with site stay periods on as required basis.

In the event of order no. of visits as follows shall be made as a minimum with charges included in the bidder's base price itself.

- **For drawings/documents approval**

In the event of order all drawings / documents in soft as well as hard copy shall be submitted as per NIT.

Further on receipt of Customer comments, if required bidder's engineer shall visit BHEL/ Customer along with soft copy to resolve all issues and incorporate comments in the soft copy for across the table finalisation and Category-I approval.

- **Site Visits :**

- No. of site visits for combined activities of erection checks and commissioning for DF as applicable shall be one per unit - for both sets of equipments of one unit. Time duration for erection and commissioning shall be "on as required basis" with equipments run for trial operation thereafter for requisite period to demonstrate satisfactory operation.

However the no. of visits may be suitably assessed by bidders as per their experience with site stay periods on as required basis.

- Bidder shall demonstrate guarantees including pressure drops, etc. at site during subsequent visit for DF of each unit.
- For trouble shooting on "as required basis".

5.0 EXCLUSIONS :

The following are excluded from the bidder's scope.

- 5.1 Civil foundation works required for installation
- 5.2 Erection of Equipment at site.

16 	TITLE : TECHNICAL SPECIFICATION	SPEC. NO: PE-TS- 410-165-N001	
	FOR	VOLUME : II B	
	DEBRIS FILTER(DF)	SECTION: C1	
		REV. NO. 0	DATE : 18.06.2015
		SHEET 5 OF 9	

6.0 DESIGN CONSTRUCTION :

In addition to the requirements of Section-D the following shall also be complied with for packages/ projects under scope of this specification:

- 6.1 The typical flow diagram applicable for the project specified herein for Debris Filter is enclosed as Annexure-II for respective projects in this Section with scope demarcation for bidder's compliance.
- 6.2 Location of Debris Filter shall be Approx. 20M Outside TG Hall 'A' Row in Transformer Yard area. Final Layout drawing shall be provided during Detailed Engineering.
- 6.3 Thickness of body flange and counter flange of DF shall be as per Drg no PE-DG-999-141-MO17 enclosed at enclosures at Annexure-III.
- 6.4 The materials of construction specified in Data Sheet-A are minimum requirements and materials of construction for other components not specified shall be similarly selected by the bidder for the intended duty which shall be subject to purchaser's approval during detailed engineering in the event of order.
- 6.5 Housing/ body of Debris Filter shall be designed and manufactured as per the applicable codes for pressure vessels and to take care of force and moments as enclosed in the specification. However in no case thickness of housing/ body shall be less than the thickness as specified in "Pipe size Table" enclosed in Data Sheet-A of Debris Filter.
- 6.6 Adequate provision for future installation of Cathodic Protection for DF (Sacrificial type shall be in Purchaser Scope) shall be kept by the bidder in the equipment..
- 6.7 Any flow straightener for streamlining the CW flow in Debris Filter if required shall be supplied by the bidder along with mounting arrangement and the fixing details. Suitable Coating for protection against Water and Touch-up Paint in sealed Container after welding in Condenser Outlet Pipe at Site to be provided by the Bidder.
- 6.8 Velocity in the pipe work shall be less than 1.5 m/ sec for pump suction and less than 2.0 m/ sec. in other pipe work. All valves upto 150 NB shall be ball valves. For higher sizes, gate/ globe/ B.F. valves shall be provided. All instrument valves shall be needle valves.

7.0 Performance Guarantee and Testing :

The Debris Filter shall be guaranteed to meet the performance requirements specified in Section-D and also for trouble free operation after commissioning. Schedule of performance guarantees (enclosed in Volume III) duly filled and signed shall be

16 	TITLE : TECHNICAL SPECIFICATION	SPEC. NO: PE-TS- 410-165-N001	
	FOR	VOLUME : II B	
	DEBRIS FILTER(DF)	SECTION: C1	
		REV. NO. 0	DATE : 18.06.2015
		SHEET 6 OF 9	

furnished with the bid.

The Performance guarantees of equipments shall stand valid till the satisfactory completion of performance testing & its acceptance by BHEL/ Consultant/Customer. If the guarantee period specified in the Commercial Specification is higher, same shall prevail.

8.0 Performance Guarantee and Bid Evaluation criteria for Debris Filter.

8.1 Debris Filters :

8.1.1 Performance Guarantee Parameters shall be as under :

- Pressure drop in Debris Filters in clean condition viz. after backwashing.

8.1.2 Bidder to note that bids shall be evaluated on account of pressure drop across Debris Filters (in clean condition) & liquidated damages on account of not meeting the same shall be in accordance with following :

A) Bid Evaluation Criteria and Liquidated Damages:

The bids received shall be evaluated for Pressure drop across Debris Filters:

- The permissible limit of pressure drop across Debris Filters in clean condition shall be 0.5 MWC.
- If the pressure drops quoted are higher than above limit, the bids shall be technically loaded @ Rate as mentioned in Data Sheet-A for ~~respective projects~~ per 0.1 MWC pressure drop.
- However no advantage shall be given for pressure drops quoted less than above permissible limit.
- The maximum acceptance limit for pressure drop across Debris Filter (with technical loading) shall be 0.8 MWC.
The bids will be technically rejected for pressure drops quoted higher than above maximum limit.
- The guaranteed pressure drops shall be demonstrated at site by vendors and if found higher shall be subject to LD @ twice the bid evaluation factor as above.

9.0 SPARES :

9.1 Recommended Spares :

Bidder to submit the list of recommended spares (along with prices) as per NIT required

16 	TITLE : TECHNICAL SPECIFICATION	SPEC. NO: PE-TS- 410-165-N001	
	FOR	VOLUME : II B	
	DEBRIS FILTER(DF)	SECTION: C1	
		REV. NO. 0	DATE : 18.06.2015
		SHEET 7 OF 9	

for three (3) years of reliable operation and maintenance of DF for BHEL reference purpose only.

The recommended spares shall not be considered for evaluation and ordering purpose.

9.2 **Mandatory Spares**

Mandatory Spares shall be as per Data Sheet-A or annexure enclosed with data sheet A.

10.0 **Quality Plan**

Bidder shall submit QP in the event of order based on the guidelines given in the specification & QP enclosed therein. QP will be subject to BHEL/ Customer approval without any price implication and customer hold points for inspection/ testing shall be marked in the QP at the contract stage. Inspection/ testing shall be witnessed as per same apart from review of various test certificates/ Inspection records etc. Charges for 3rd party inspection (TUV/ equivalent) for imported components wherever required shall be included by bidder in the base price itself. Witness for all the test identified under agency "C" & "N" in Quality plan shall be by third party.

If BHEL or BHEL customer decides to witness the tests along with third party, the cost of travel of BHEL or BHEL customer shall be borne by BHEL or BHEL customer themselves.

11.0 **DELIVERY & DRAWINGS/ DOCUMENTS DISTRIBUTION SCHEDULE :**

a. Delivery of Equipment for each project shall be as per NIT.

b. Drawings submission schedule shall be as per NIT/as advised by Project Group.

12.0 The makes of various bought out items shall be subjected to purchaser's approval in the event of order.

13.0 It is mandatory for the bidders to submit along with the bid the deviations if any whether major or minor in the schedule of deviations only. ***In the absence of deviations listed in the schedule of deviations the offer shall be deemed to be in full conformity with the specification "non-withstanding" anything else stated elsewhere in bidder's offer, data sheets etc. The implied/ indirect deviations in data sheets etc. Shall not be binding on the purchaser.***

14.0 The following documents shall be furnished by the bidder with his offer :

- Compliance certificate duly signed and stamped (Enclosed at Schedules).



TITLE : TECHNICAL SPECIFICATION

SPEC. NO: PE-TS- 410-165-N001

FOR

VOLUME : II B

DEBRIS FILTER(DF)

SECTION: C1

REV. NO. 0

DATE : 18.06.2015

SHEET 8 OF 9

- Guarantee schedule duly signed and stamped (Enclosed at Schedules).
- GA drawings of following with empty/ filled-ups.
 - Debris Filter
 - Debris Flushing pumps (if applicable)
 - Other equipments considered necessary for Layout/ Civil.
- Electrical Load Data (Enclosed at Vol. III of Specification)
- Schedule of Deviation (Enclosed at Schedules).

The bidder to note that load requirement furnished and finalised during tender stage shall only be provided by BHEL and any changes or additional requirement of Electrical load by bidder during contract stage shall be provided by BHEL with cost repercussions to the bidder.

NOTE: Apart from above, no other drawing/ document/ data sheet etc. shall be submitted along with the offer. If any drawing/ document etc. is submitted with the offer, same shall be considered as for '**Reference**' purpose only and shall not be reviewed/ commented upon and any deviation, exclusion to scope, etc. taken in documents but not highlighted in the deviation schedule shall not be taken cognizance of.

15.0 **Important Note:-**

- i. Bidder to note that C&I, Electrical, Fragile materials, shall be sent in separate proper packing (segregating from heavy items).
- ii. Bidder to include handling instructions in engineering drg/doc and packing to be done in such a way to avoid damage of items mention above in transit and long storage at site and same shall be approved in contract stage by BHEL/Customer.
- iii. For detail despatch instruction, please refer Special Conditions of Contract (SCC) for the project.

16 	TITLE : TECHNICAL SPECIFICATION FOR DEBRIS FILTER(DF)	SPEC. NO: PE-TS- 410-165-N001	
		VOLUME : II B	
		SECTION: C1	
		REV. NO. 0	DATE : 18.06.2015
SHEET 9 OF 9			

ANNEXURE-I

DEBRIS FILTER

SL.NO.	Projects	Size (NB)	Length of Debris Filter (Including Counter Flange)	Scope of Counter Flange	Scope of Gaskets, nuts and bolts.
1	1X800MW KOTHAGUDEM, TPS, STAGE-VII, UNIT#12	2700 NB	5000 mm	In Bidder's Scope.	In Bidder's Scope.

MINIMUM BOQ OF DEBRIS DISPOSAL PIPE WORK:

- A) For 2 sets of Debris Filters
 - i) Pipe - 60M
 - ii) 90 elbow - 10 Nos

Note: : Any Interconnecting piping including debris disposal pipe shall be in bidder's scope.

ANNEXURE-II

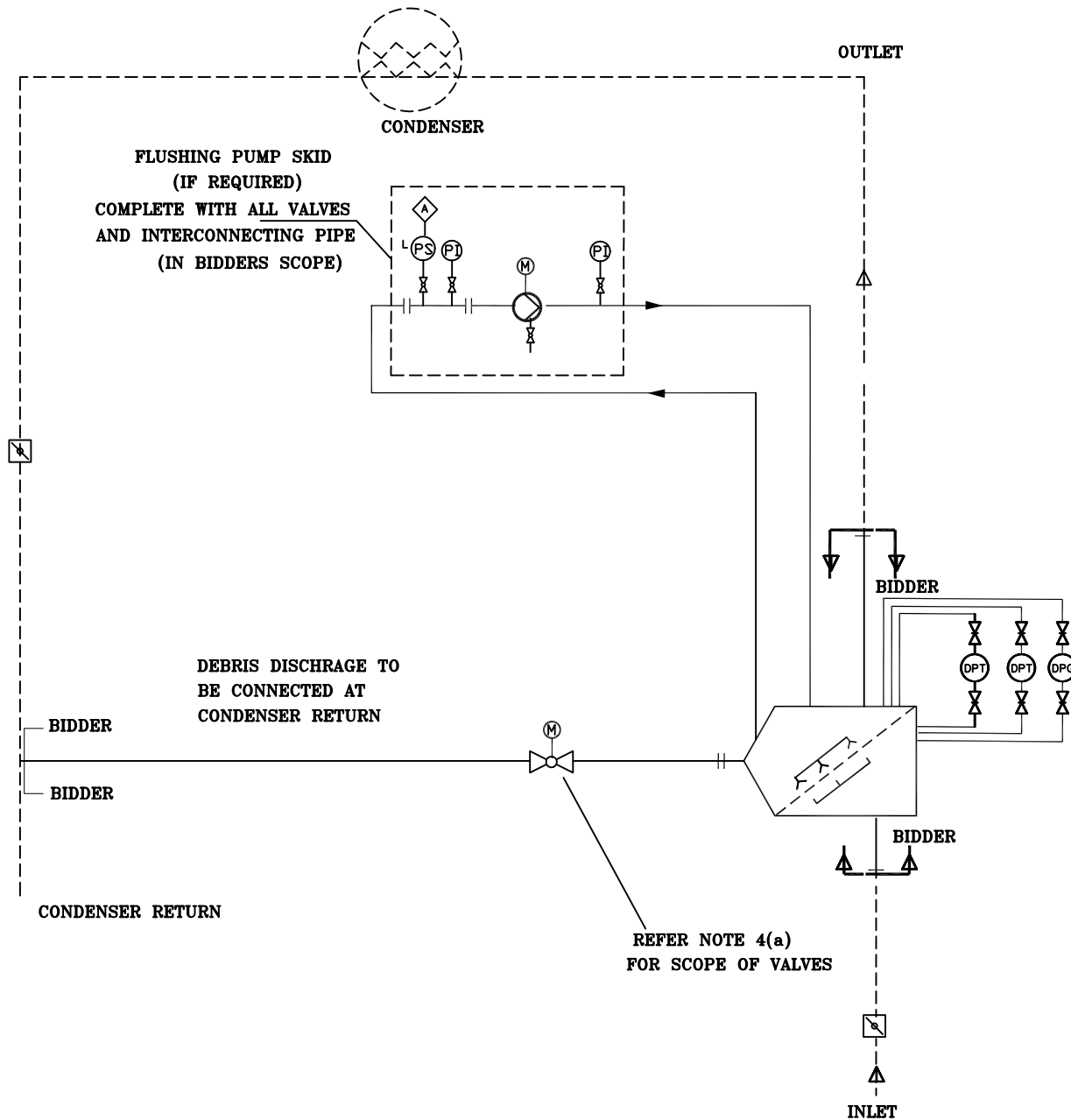

NOTE :-

1. SCHEMATIC SHOWN IS TYPICAL FOR ONE DF, SHALL BE IDENTICAL FOR THE SECOND DF.
2. INSTRUMENTS/ANNUNCIATIONS/ INTERLOCKS INDICATED IN THE SCHEME ARE TENTATIVE, SHALL BE PROVIDED AS PER APPROVED DRGS./ DOCUMENTS/ CONTROL PHILOSOPHY IN THE EVENT OF ORDER.
3. COUNTERFLANGES FOR DF ARE INCLUDED IN BIDDERS SCOPE. ALL INTERCONNECTING / DEBRIS DISPOSAL PIPING IS INCLUDED IN BIDDER'S SCOPE.
4. BIDDER'S SCOPE OF SUPPLY ALSO INCLUDES :
 - a) ALL VALVES ON BIDDER'S INTERCONNECTING /DEBRIS DISPOSAL PIPING ALONGWITH THEIR COUNTERFLANGES.
 - b) FLUSHING PUMP SKID, IF REQUIRED COMPLETE WITH FLUSHING PUMP, VALVES, INSTRUMENTS, PIPING ETC.
5. PURCHASER BIDDER'S SCOPE OF SUPPLY

**FLOW DIAGRAM FOR
DEBRIS FILTER**

FIRST ANGLE PROJECTION

ALL DIMENSIONS ARE IN MM

DRAWING NO. PE-DG-999-141-M017

ANNEXURE-III

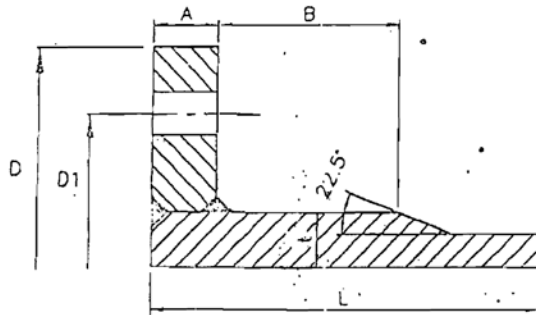

NOTES:-

Flange thicknesses listed are for Design pressure=5Kg/cm²(g) and Flange dimensions as given in the table. Final thickness of the flange is to be checked for actual OD/Bolting PCD/Neck dimensions.

PIPE SIZE	PIPE THK.	FLANGE OD 'D'	Bolt PCD 'D1'	WELD NECK FLANGE				SLIP-ON FLANGE THICKNESS
				FLANGE THK. 'A'	NECK THK. 't'	NECK Length 'B'	Appx. Total Length 'L'	
1200	10-12	1465	1380	40	24	70	200	90
1400	14	1675	1590	50	24	70	200	100
1600	14	1915	1920	60	32	80	220	110
1800	14-16	2115	2020	70	32	90	250	120
2200	18	2550	2420	80	36	100	300	140
2300	20			90	38	110	325	150
2500	20			90	38	110	325	150
2700	20			90	38	110	325	150

TENTATIVE

DRAWING FOR BAL. SEPARATOR COUNTER FLANGE

RCV.	DATE	ALTU	CHD	APPD	JOB NO.	999
					STATUS	-
					DISTRIBUTION	



DHARAT HEAVY ELECTRICALS LTD
POWER GROUP
PROJECTS ENGINEERING MANAGEMENT
PPEI, NOIDA

DEPT CODE	NAME	SIGN	DATE
JRN	PH		25.06.07
DSGN	PH		25.06.07
CHD	SPV		25.06.07
APPD	SM		25.06.07

TITLE
COUNTER FLANGE DETAILS

DRAWING NO.	PE-DG-999-141-M017
SHEET 01 OF 01	REV 00

17

120

141



**TITLE : TECHNICAL SPECIFICATION
FOR
DEBRIS FILTER (DF)**

SPEC. NO. PE-TS- 410-165-N001

VOLUME : II B

SECTION : C

REV. NO. 0

DATE : 18.06.2015

SHEET

1

of

1

**SECTION C2
DEBRIS FILTER
(ELECTRICAL DETAILS)**



TITLE: ELECTRICAL EQUIPMENT SPECIFICATION FOR DF 1 X 800 MW KOTHAGUDEM TPS	SPECIFICATION NO.
	VOLUME NO. : II-B
	SECTION: C
	REV NO. : 00 DATE: 15.06.2015
	SHEET: 1 OF 1

1.0 **EQUIPMENT & SERVICES TO BE PROVIDED BY BIDDER:**

- a) Services and equipment as per "Electrical Scope between BHEL and Vendor".
- b) Any item/work either supply of equipment or erection material which have not been specifically mentioned but are necessary to complete the work for trouble free and efficient operation of the plant shall be deemed to be included within the scope of this specification. The bidder without any extra charge shall provide the same.
- c) Supply of mandatory spares as specified in the specifications of mechanical equipment.
- d) Erection and commissioning spares.
- e) Erection & Maintenance tools & tackles.
- f) Electrical load requirement for DF.
- g) All equipment shall be suitable for the power supply fault levels and other climatic conditions mentioned in the enclosed project information.
- h) Bidder to furnish list of makes for each equipment at contract stage, which shall be subject to customer /BHEL approval without any commercial and delivery implications to BHEL.
- i) Various drawings, data sheet as per required format, quality plans, calculations, Type test & Routine test reports & certificates, operation and maintenance manuals, Complete technical literature with catalogues etc shall be furnished as specified at contract stage. All documents shall be subject to customer /BHEL approval without any commercial implications to BHEL.
- j) Motor shall meet minimum requirement of motor specification.
- k) LT power & control cables shall meet minimum requirement of LT power & control cables specification.
- l) Cabling, earthing & lightning protection shall meet minimum requirement of cabling, earthing & lightning protection specification.
- m) The sub-vendor list for various electrical items is subject to BHEL/Customer approval without any commercial implications.

2.0 **EQUIPMENT & SERVICES TO BE PROVIDED BY PURCHASER FOR ELECTRICAL & TERMINAL POINTS:**

Refer "Electrical Scope between BHEL and Vendor".

3.0 **DOCUMENTS TO BE SUBMITTED ALONG WITH BID**

- 3.1 Bidder shall confirm total compliance to the electrical specification without any deviation from the technical/ quality assurance requirements stipulated. In line with this, the bidder as technical offer shall furnish two signed and stamped copies of the following:
- a) **A copy of this sheet "Electrical Equipment Specification for DF" and sheet "Electrical Scope between BHEL and Vendor" with bidder's signature and company stamp.**
 - b) List of Erection and Commissioning spares.
 - c) List of Erection & Maintenance tools & tackles.
 - d) Electrical load requirement.
 - e) If there is any conflict, customer motor specification will prevail over BHEL motor specification.



TITLE:
**ELECTRICAL EQUIPMENT SPECIFICATION
FOR
DF
1 X 800 MW KOTHAGUDEM TPS**

SPECIFICATION NO.
VOLUME NO. : **II-B**
SECTION: **C**
REV NO. : **00** DATE: 15.06.2015
SHEET: 1 OF 1

3.2 No technical submittal such as copies of data sheets, drawings, write-up, quality plans, type test certificates, technical literature, etc. is required during tender stage. Any such submission even if made, shall not be considered as part of offer.

4.0 LIST OF ENCLOSURES

- 4.1 Electrical scope sheet between BHEL & Vendor.
- 4.2 Customer Spec. for LV Motors.
- 4.3 General requirement of LV Motors.
- 4.4 Data Sheet - A for LV Motors.
- 4.5 Electrical Load Data Format.
- 4.6 Datasheet-C (to be filled by Vendor)
- 4.7 QP for LV motors
- 4.8 Customer Specification for Cables
- ~~4.9 Customer Specification for Erection Cabling, Grounding And Lightning Protection~~
- ~~4.10 Customer Specification for Illumination~~
- 4.11 Customer Specification for LT Switchgear

STANDARD ELECTRICAL SCOPE BETWEEN BHEL AND VENDOR (FOR EPC PROJECTS)

PACKAGES: DF

SCOPE OF VENDOR: SUPPLY

PROJECT:

S.NO	DETAILS	SCOPE SUPPLY	SCOPE E&C	REMARKS
1	415V MCC Starter cum control panel (if applicable)	BHEL Vendor	BHEL BHEL	415 V AC, 3 phase, 3 wire supply shall be provided by BHEL based on load data provided by vendor at contract stage for all equipment supplied by vendor as part of contract. Any other voltage level (AC/DC) required will be derived by the vendor.
2	Local Push Button Station (for motors)	BHEL	BHEL	Located near the motor.
3	Power cables, control cables and screened control cables for a) both end equipment in BHEL's scope b) both end equipment in vendor's scope c) one end equipment in vendor's scope	BHEL Vendor BHEL	BHEL BHEL BHEL	1. For 3.b) & c): Sizes of cables required shall be informed by vendor at contract stage (based on inputs provided by BHEL) in the form of cable listing. Finalisation of cable sizes shall be done by BHEL. Vendor shall provide lugs & glands accordingly. 2. Cabling/ termination by BHEL.
4	Junction box for control & instrumentation cable	Vendor	BHEL	Number of Junction Boxes shall be sufficient and positioned in the field to minimize local cabling (max 10-12 mtrs) and trunk cable.
5	Any special type of cable like compensating, co-axial, prefab, MICC, fibre optical etc.	Vendor	BHEL	Refer scope/ C&I portion of specification for scope of fibre Optical cables if used between PLC/ micro processor & DCS.
6	Cable trays, accessories & cable trays supporting system	BHEL	BHEL	
7	Cable glands and lugs for equipment supplied by Vendor	Vendor	BHEL	1. Double compression Ni-Cr plated brass cable glands 2. Solder less crimping type heavy duty copper lugs for power & control cables.
8	Conduit and conduit accessories for cabling between equipment supplied by vendor	Vendor	BHEL	Conduits shall be medium duty, hot dip galvanised cold rolled mild steel rigid conduit as per IS: 9537.
9	Lighting	BHEL	BHEL	
10	Equipment grounding & lightning protection	BHEL	BHEL	

STANDARD ELECTRICAL SCOPE BETWEEN BHEL AND VENDOR (FOR EPC PROJECTS)

PACKAGES: DF

SCOPE OF VENDOR: SUPPLY

PROJECT:

S.NO	DETAILS	SCOPE SUPPLY	SCOPE E&C	REMARKS
11	Below grade grounding	BHEL	BHEL	
12	LT Motors with base plate and foundation hardware	Vendor	BHEL	Makes shall be subject to customer/ BHEL approval at contract stage.
13	Mandatory spares	Vendor	-	Vendor to quote as per specification.
14	Recommended O & M spares	Vendor	-	As specified elsewhere in specification
15	Any other equipment/ material/ service required for completeness of system based on system offered by the vendor (to ensure trouble free and efficient operation of the system).	Vendor	BHEL	
16	a) Input cable schedules (Control & Screened Control Cables) b) Cable interconnection details for above c) Cable block diagram	Vendor Vendor Vendor	- - -	Cable listing for Control and Instrumentation Cable in enclosed excel format shall be submitted by vendor during detailed engineering stage.
17	Equipment layout drawings	Vendor	-	For preparation of cabling layout drawings by BHEL, vendor shall furnish Electrical equipment layout drawings (both in print form as well as in AUTOCAD) of the complete plant (including electrical area) indicating location and identification of all equipment requiring cabling,
18	Electrical Equipment GA drawing	Vendor	-	For necessary interface review.

NOTES:

1. Make of all electrical equipment/ items supplied shall be reputed make & shall be subject to approval of BHEL/customer after award of contract.
2. All QPs shall be subject to approval of BHEL/customer after award of contract without any commercial implication.
3. In case the requirement of Junction Box arises on account of Power Cable size mis-match due to vendor engineering at later stage, vendor shall supply the Junction Box for suitable termination.

VOLUME: V-A

SECTION-II

**TECHNICAL SPECIFICATION
FOR
A.C. & D.C. MOTORS**

CONTENT

CLAUSE NO.	DESCRIPTION
1.00.00	SCOPE
2.00.00	CODES & STANDARDS
3.00.00	SERVICE CONDITIONS
4.00.00	TYPE AND RATING
5.00.00	PERFORMANCE
6.00.00	SPECIFIC REQUIREMENTS
7.00.00	ACCESSORIES
8.00.00	TESTS
9.00.00	DRAWINGS, DATA & MANUALS

ATTACHMENT

ANNEXURE-A	DESIGN DATA
------------	-------------

VOLUME: V-A

SECTION-II

**TECHNICAL SPECIFICATION
FOR
A.C. & D.C. MOTORS**

- 1.00.00 **SCOPE**
- 1.01.00 This section covers the general requirements of the drive motors for power station auxiliary equipment.
- 1.02.00 Motors shall be furnished in accordance with both this general specification and the accompanying driven equipment specification.
- 1.03.00 In case of any discrepancy, the driven equipment specification shall govern.
- 2.00.00 **CODES & STANDARDS**
- 2.01.00 All motors shall conform to the latest applicable IS, IEC and CBIP Standards/Publications except when otherwise stated herein or in the driven equipment specification.
- 2.02.00 Major standards, which shall be followed, are listed below other applicable Indian Standards for any component part even if not covered in the listed standards shall also be followed:
- i) IS-325
 - ii) IS-12615
 - iii) IEC-60034
- 3.00.00 **SERVICE CONDITIONS**
- 3.01.00 The motors will be installed in hot, humid and tropical atmosphere highly polluted at places with coal dust and/or fly ash.
- 3.02.00 Unless otherwise noted, electrical equipment/system design shall be based on the service conditions and auxiliary power supply given in the annexure to this specification.
- 3.03.00 For motor installed outdoor and exposed to direct sunrays, the effect of solar heat shall be considered in the determination of the design ambient temperature.
- 4.00.00 **TYPE AND RATING**
- 4.01.00 **A.C. Motors**
- 4.01.01 Motors shall be general purpose, constant speed, squirrel cage, three/single phase, induction type.

- 4.01.02 All motors shall be rated for continuous duty. They shall also be suitable for long period of inactivity.
- 4.01.03 LT motor & HT motor name-plate rating at 50°C shall have at least 15% margin and 10% margin respectively over the input power requirement of the driven equipment at rated duty point unless stated otherwise in driven equipment specification.
- 4.01.04 The motor characteristics shall match the requirements of the driven equipment so that adequate starting, accelerating, pull up, break down and full load torques are available for the intended service.
- 4.01.05 Motors efficiency class shall be IE1, IE2 as per latest version of IEC-60034.
- 4.02.00 **D.C. Motors**
- 4.02.01 D.C. motor provided for emergency service shall be shunt/compound wound type.
- 4.02.02 Motor shall be sized for operation with fixed resistance starter for maximum reliability.
- Starter panel complete with all accessories shall be included in the scope of supply.
- 5.00.00 **PERFORMANCE**
- 5.01.00 **Running Requirements**
- 5.01.01 Motor shall run continuously at rated output over the entire range of voltage and frequency variations as given in the annexure.
- 5.01.02 The motor shall be capable of operating satisfactorily at full load for 5 minutes without injurious heating with 75% rated voltage at motor terminals.
- 5.01.03 The motor shall be designed to withstand momentary overload of 60% of full load torque for 15 second without any damage.
- 5.02.00 **Starting Requirements**
- Motor shall be designed for direct online starting at full voltage. Breakaway starting current as percentage of full load current for various motor rating shall not exceed the given below-
- | | | |
|---------------------|---|---|
| Motors up to 1500kW | - | 600% subject to IS tolerance of plus 20%. |
| Motors above 1500kW | - | 450% not subject to any positive tolerance. |
- 5.02.01 The motor shall be capable of withstanding the stresses imposed if started at 110% rated voltage.

- 5.02.02 Motor shall start with rated load and accelerate to full speed with 80% rated voltage at motor terminals except mill motor. Mill motor shall start with rated load and accelerate to full speed at 85% of the rated voltage at the motor terminals.
- 5.02.03 a) Two hot starts in succession with motor initially at normal running temperature.
b) Pump motor subject to reverse rotation shall be designed to withstand the stresses encountered when starting with shaft rotating at 125% rated speed in reverse direction.
- 5.02.04 The motors shall be designed to withstand 120% of rated speed for 2 minutes without any mechanical damage.
- 5.03.00 **Stress During Bus Transfer**
- 5.03.01 The motor may be subjected to sudden application of 150% rated voltage during bus transfer, due to the phase difference between the incoming voltage and motor residual voltage.
- 5.03.02 The motor shall be designed to withstand any torsional and/or high current stresses, which may result, without experiencing any deterioration in the normal life and performance characteristics.
- 5.04.00 **Locked Rotor Withstand Time**
- 5.04.01 The locked rotor withstand time under hot condition at 110% rated voltage shall be more than motor starting time by at least 3 seconds for motors up to 20 seconds starting time and by 5 seconds for motor with more than 20 seconds starting time.
- 5.04.02 Starting time mentioned above is at minimum permissible voltage of 80% rated voltage.
- 5.04.03 Hot thermal withstand curve shall have a margin of at least 10% over the full load current of the motor to permit relay setting utilising motor rated capacity.
- 6.00.00 **SPECIFIC REQUIREMENTS**
- 6.01.00 **Enclosure**
- 6.01.01 All motor enclosures for outdoor, semi-outdoor & indoor application shall conform to the degree of protection IP-55 unless otherwise specified. Motor for outdoor or semi-outdoor service shall be of weather-proof construction with canopy.
- 6.01.02 For hazardous area approved type of increased safety enclosure shall be furnished.
- 6.02.00 **Cooling**
- 6.02.01 The motor shall be self ventilated type, either totally enclosed fan cooled IC 411(TEFC), totally enclosed tube ventilated IC 511(TETV) or closed air circuit air- cooled IC 611(CACA).

- 6.02.02 For large capacity motors not available with above type of cooling may be accepted with IC 81W or IC 91W, closed air circuit water cooled (CACW) subject to the approval of the owner.
- 6.03.00 **Winding and Insulation**
- 6.03.01 All insulated winding shall be of copper.
- 6.03.02 All motors shall have class F insulation but limited to class B temperature rise.
- 6.03.03 Windings shall be impregnated to make them non-hygroscopic and oil resistant.
- 6.04.00 **Tropical Protection**
- 6.04.01 All motors shall have fungus protection involving special treatment of insulation and metal against fungus, insects and corrosion.
- 6.04.02 All fittings and hardwares shall be corrosion resistant.
- 6.05.00 **Bearings**
- 6.05.01 Motor shall be provided with antifriction bearings, unless sleeve bearings are required by the motor application. Bearings shall be rated for minimum service life of 40,000Hrs.
- 6.05.02 Vertical shaft motors shall be provided with thrust and guide bearings. Thrust bearing of tilting pad type is preferred.
- 6.05.03 Bearings shall be provided with seals to prevent leakage of lubricant or entrance of foreign matters like dirt, water etc. into the bearing area.
- 6.05.04 Sleeve bearings shall be split type, ring oiled, with permanently aligned, close running shaft sleeves.
- 6.05.05 Grease lubricated bearings shall be pre-lubricated and shall have provisions for in-service positive lubrication with drains to guard against over lubrication. LT motors 15kW and above shall be provided with external greasing arrangement.
- 6.05.06 Oiled bearing shall have an integral self cooled oil reservoir with oil ring inspection ports, oil sight glass with oil level marked for standstill and running conditions and oil fill and drain plugs.
- 6.05.07 Forced lubricated or water cooled bearing shall not be used without prior approval of Owner.
- 6.05.08 Lubricant shall not deteriorate under all service conditions. The lubricant shall be limited to normally available types with IOC equivalent.
- 6.05.09 Bearings shall be insulated as required to prevent shaft current and resultant bearing damage.
- 6.06.00 **Noise & Vibration**

- 6.06.01 All HT motors shall be provided with vibration pads for mounting of vibration detectors. Vibration monitoring devices shall be provided on DE and NDE side in x&y direction with remote DCS monitoring, alarm and tripping.
- 6.06.02 The maximum double amplitude vibrations for HT motors upto 1500 rpm shall be 25 microns and 15 microns upto 3000 rpm. For 415V motors, maximum double amplitude vibrations upto 1500 rpm shall be 40 microns and 15 microns upto 3000 rpm.
- 6.06.03 The noise level shall not exceed 85db (A) at 1.5 meters from the motor.
- 6.07.00 **Motor Terminal Box**
- 6.07.01 Motor terminal box shall be detachable type and located in accordance with Indian Standards clearing the motor base- plate/ foundation
- 6.07.02 Terminal box shall be capable of being turned 360 Deg. in steps of 180 Deg. for HT motors and 90 Deg. for LT motors unless otherwise approved.
- 6.07.03 The terminal box shall be split type with removable cover with access to connections and shall have the same degree of protection as motor.
- 6.07.04 The terminal box shall have sufficient space inside for termination/connection of XLPE insulated armoured aluminium cables.
- 6.07.05 Terminals shall be stud or lead wire type, substantially constructed and thoroughly insulated from the frame.
- 6.07.06 The terminals shall be clearly identified by phase markings, with corresponding direction of rotation marked on the non-driving end of the motor.
- 6.07.07 The terminal box shall be capable of withstanding maximum system fault current for a duration of 0.25 sec.
- 6.07.08 For 11000V and 3300V motor, the terminal box shall be phase-segregated type. The neutral leads shall be brought out in a separate terminal box (not necessarily phase segregated type) with shorting links for star connection.
- 6.07.09 Motor terminal box shall be furnished with suitable cable lugs and double compression brass glands to match with cable used.
- 6.07.10 The gland plate for single core cable shall be non-magnetic type.
- 6.07.11 Minimum clearances to be provided between phase to phase and phase to earth shall be as under-

Voltage Rating of Motor	Minimum Ph-Ph & Ph-Earth clearance
0.415 kV	: 25 mm
3.3 kV	: 65 mm
11.0 kV	: 140 mm

Note: In case it is not possible to maintain these clearances, the live parts shall be totally insulated from earth and other Phases. Adequate clearances shall be provided for cable connections.

6.08.00 Grounding

6.08.01 The frame of each motor shall be provided with two separate and distinct grounding pads complete with tapped hole, GI bolts and washer.

6.08.02 The grounding connection shall be suitable for accommodation of ground conductors as follows:

Rating			Conductor Size
Above	Up to		
-----	5.5 kW	:	8 SWG GI Wires.
5.5 kW	22 kW	:	25mm X 4mm GS Flat.
23 kW	55 kW	:	40mm X 6mm GS Flat.
56kW	174kW	:	50mm X 8mm GS Flat.
175kW	ABOVE	:	75mm X 10mm GS Flat.

6.08.03 The cable terminal box shall have a separate grounding pad.

6.09.00 Minimum Cable Size for LT & HT Motors shall as be as follows-

a) For 415V, 3-Ph, LT Motors-

Rating		:	Cable Size
Above	Up to		
-----	5.5 kW	:	1R X 3C X 6 Sq.mm
5.5 kW	11 kW	:	1R X 3C X 10 Sq.mm
11 kW	22 kW	:	1R X 3C X 35 Sq.mm
22 kW	37.5 kW	:	1R X 3C X 70 Sq.mm.
37.5kW	55 kW	:	1R X 3C X 150 Sq.mm
55 kW	75 kW	:	1R X 3C X 300 Sq.mm
75 kW	110kW	:	2R X 3C X 150 Sq.mm
110 kW	175kW	:	2R X 3C X 300 Sq.mm

b) For 3.3kV & 11kV, 3-Ph, HT Motors-

Rating		:	Cable Size
Above	Up to		

175 kW	1000 kW	:	1R X 3C X 240 Sq.mm
1000 kW	2000 kW	:	2R X 3C X 240 Sq.mm
2000 kW	4500 kW	:	2R X 3C X 300 Sq.mm
4501 kW	10,000 kW	:	9R X 1C X 1000 Sq.mm.

Note: During detail engineering if higher cable size is required same shall be provided.

6.10.00 **Rating Plate**

In addition to the minimum information required by IS, the following information shall be shown on motor rating plate :

- a) Temperature rise in Deg.C under rated condition and method of measurement.
- b) Degree of protection.
- c) Bearing identification no. and recommended lubricant.
- d) Location of insulated bearings.

7.00.00 **ACCESSORIES**

7.01.00 **General**

Accessories shall be furnished, as listed below, or if otherwise required by driven equipment specification or application.

7.02.00 **Space Heater**

7.02.01 Motor of rating 30 kW and above shall be provided with space heaters, suitably located for easy removal or replacement.

7.02.02 The space heater shall be rated 240 V, 1 Phase, 50Hz and sized to maintain the motor internal temperature above dew point when the motor is idle.

7.02.03 Minimum Cable Size for space heater shall be as listed-

- i) For LT motors: 2.5 sq.mm, 2-Core copper cable complying with IS-1554(Part-1).
- ii) For HT motors: 6 sq.mm, 2 Core aluminium cable complying with IS-1554(Part-1).

7.03.00 **Temperature Detectors**

7.03.01 All 11000V and 3300V motors shall be provided with twelve (12) nos. simplex type winding temperature detectors, four (4) nos. per phase.

- 7.03.02 11000V and 3300V motor bearing shall be provided with duplex type temperature detectors.
- 7.03.03 The temperature detector mentioned above shall be resistance type, 3 wire, platinum wound, 100 Ohms at 0°C.
- 7.03.04 Leads of all simplex type motor winding RTDS and motor bearing RTDS shall be wired up to respective switchgear metering & protection compartment. From which one set of RTDS will be connected to numerical protection relay and another set shall be kept free for DDCMIS connectivity.
- 7.03.05 0.5 sq.mm annealed tinned copper conductor complying with IS-1554(Part-1). shall be used for RTD/BTD wiring.
- 7.04.00 **Indicator/Switch**
- 7.04.01 Dial type local indicator with alarm contacts shall be provided for the following:
- a) 11000 V and 3300V motor bearing temperature.
 - b) Hot and cold air temperature of the closed air circuit for CACA and CACW motor.
- 7.04.02 Flow switches shall be provided for monitoring cooling water flow of CACW motor and oil flow of forced lubrication bearing, if used. CACW motor shall be provided with water leakage detector with remote alarm and tripping.
- 7.04.03 Alarm switch contact rating shall be minimum 2.0 A at 220V D.C. and 10A at 240V A.C.
- 7.05.00 **Current Transformer for Differential Protection**
- 7.05.01 Motor 1000 kW and above shall be provided with three differential current transformers mounted over the neutral leads within the enclosure.
- 7.05.02 The arrangement shall be such as to permit easy access for C.T. testing and replacement. Current transformer characteristics shall match Owner's requirements to be intimated later.
- 7.06.00 **Accessory Terminal Box**
- 7.06.01 All accessory equipment such as space heater, temperature detector, current transformers etc., shall be wired to and terminated in terminal boxes, separate from and independent of motor (power) terminal box.
- 7.06.02 Accessory terminal box shall be complete with double compression brass glands and pressure type terminals to suit owner's cable connections.
- 7.07.00 **Drain Plug**
- Motor shall have drain plugs so located that they will drain the water, resulting from the condensation or other causes from all pockets of the motor casing.

7.08.00 **Lifting Provisions**

Motor weighing 25 Kg. or more shall be provided with eyebolt or other adequate provision of lifting.

7.09.00 **Dowel Pins**

The motor shall be designed to permit easy access for drilling holes through motor feet or mounting flange for installation of dowel pins after assembling the motor and driven equipment.

7.10.00 **Painting**

For paint shade finish, refer Section-X of Volume: II-A : Lead Specification.

8.00.00 **TESTS**

Routine and Type Tests are to be conducted in presence of customer's representative as per IS:325 and in addition, any special test called for in the driven equipment specification shall be performed and required copies of test certificates are to be furnished for approval. In addition, following tests shall have to be carried out on the motors in presence of OWNER's representative on 3.3kV/11kV motors.

- a. Impulse test by 1.2 / 50 micro sec. On sample coil of Stator winding insulation as type test as per IEC-60034, part -15 test voltages as under :

Voltage rating of motor	Impulse Test Voltage
3.3 kV	18 kV peak
11 kV	49 kV peak

- b. Tan delta, charging current and dielectric loss measurements on each phase of motor stator winding as routine test.
- c. Polarization Index Test as per IS: 7816 as routine test
- d. Test for suitability of IPW- 55(Weather proof) as per IS 4691 as type test. Type test certificate for first numeral shall be acceptable in lieu to test, provided the test motor is identical to motor being supplied. Second numeral test shall be carried out on one motor of each type and rating.
- e. Fault Withstand Test for main terminal box as type test. Type test certificate shall be acceptable, if the test is conducted on exactly identical terminal box.
- f. Test for noise level as routine test.
- g. Test for vibration as routine test.

- h. Tan delta measurement on coils.
- i. Surge withstand test for inter turn insulation.
- j. Test to diagnose rotor bar failure during manufacture.
- k. Over speed test as routine test.
- l. Temperature rise test.

Temperature rise under normal condition above ambient temperature shall be limited to-

Specified Design Ambient temperature	Thermometer Method	Resistance Method
50 deg.C	60 deg.C	70 deg.C
45 deg.C	65 deg.C	75 deg.C
40 deg.C	70 deg.C	80 deg.C

Tests indicated at (h), (i), (j) shall be carried out during manufacture of the coils and shall be furnished for verification.

9.00.00 **DRAWINGS, DATA & MANUALS**

9.01.00 Drawings, Data & Manuals shall be submitted in triplicate with the bid and in quantities and procedures as specified in General Conditions of Contract and/or elsewhere in the specification for approval and subsequent distribution after the issue of 'Letter of Intent'.

9.02.00 **To be Submitted with the bid**

- a) List of the motors
- b) Individual motor data sheet as per format of the proposal data sheets.
- c) Scheme & write-up on forced lubrication system, if any
- d) Type test report

9.03.00 **To be submitted for Owner / Purchaser's Approval and Distribution**

All relevant drawings and data pertaining to the equipment like GTP, GA drawing, foundation plan, QAP, etc. shall be submitted by the Bidder for approval of Owner/Owner's consultant. Also refer clause no. 1.19.02(u) of Section-I of Volume – V-A: Technical Specifications for Electrical Equipment & Accessories.

ANNEXURE-A

DESIGN DATA

1.0 AUXILIARY POWER SUPPLY

Supply	Description	Consumer
H.V. Supply	11000 V, 3Ø, 3W, 50 Hz, Non-effectively earthed Fault level 44 kA symm. for 1 sec.	Motors 1500 kW & above
M.V. Supply	3300 V, 3Ø, 3W, 50 Hz, Non-effectively earthed Fault level 40 kA symm. for 1 sec.	Motors 175 kW and Up to less than 1500 kW.
L.V. Supply (i)	415V, 3Ø, 3W, 50 Hz effectively earthed Fault level 50 kA symm. for 1 sec.	Motors above 0.2kW and below 175kW.
(ii)	240V AC/415V AC 240V, 1Ø, 2W, 50 Hz effectively earthed	Motors upto 0.2kW. Lighting, Space heat- ing , A.C supply for Contr- ol & protective devices.
D.C. Supply	220V, 2W, unearthed Fault level 25* kA. for 1 sec.	D.C. alarm, control & protective devices

* Indicative only, the actual value will be decided by the Bidder, after substantiating the same by calculation.

Note-

- 415V or 3.3 kV may be adopted by the bidder for the drives in the range of 160-210 kW.
- 3.3 kV AC supply for CHP conveyor motors of rating above 160 kW is to be used.
- The voltage rating of the drives indicated above is for basic guideline. Minor variations can be accepted on case to case basis based on techno-economic considerations of the various sub-systems.
- Voltage rating for special purpose motors viz, VFD and screw compressors, shall be as per manufacturer's standard. All the motors ratings on Stacker/ reclaimer shall be 415V ac supply only.

2.0 RANGE OF VARIATION

A.C. Supply :

Voltage : $\pm 10\%$
Frequency : +3% to -5%
Combined Volt + frequency : 10% (absolute sum)

During starting of large motor, the voltage may drop to 80% of the rated voltage for a period of 60 seconds. All electrical equipment while running shall successfully ride over such period without affecting system performance.

D.C. Supply :

Voltage : 187 to 242 Volt

VOLUME : V-B

SECTION-IV

**TECHNICAL SPECIFICATION
FOR
CABLES**

CONTENT

CLAUSE NO.	DESCRIPTION
1.00.00	SCOPE OF SUPPLY
2.00.00	CODES & STANDARDS
3.00.00	DESIGN CRITERIA
4.00.00	SPECIFIC REQUIREMENTS
5.00.00	TESTS
6.00.00	DRAWINGS DATA & MANUALS

ATTACHMENTS

ANNEXURE-A	RATINGS AND REQUIREMENTS - H.V POWER CABLES (11KV & 3.3 KV)
ANNEXURE-B	RATINGS AND REQUIREMENTS - L.V POWER CABLES
ANNEXURE-C	RATINGS AND REQUIREMENTS - CONTROL CABLES
ANNEXURE-D	RATINGS AND REQUIREMENTS - 1.1KV FS POWER & CONTROL CABLE
ANNEXURE-E	RATINGS AND REQUIREMENTS - FLEXIBLE TRAILING CABLES
ANNEXURE-F	CABLE SIZES

SECTION-IV

TECHNICAL SPECIFICATION FOR CABLES

1.00.00 SCOPE OF SUPPLY

1.01.00 Power and Control Cables shall cover the requirement of entire Plant including the switchyard.

Other cables including special cables, if any, which may be necessary as per proven engineering practice for satisfactory and trouble free operation of the entire cable system of the plant shall also be within the scope of supply. These shall include all such cables for electrical integral with mechanical equipment systems and subsystems.

1.02.00 Cable shall be furnished in accordance with this specification and the following annexures :

- a) 11kV & 3.3 kV Power cables : Annexure - A
- b) 1100V Power Cables : Annexure – B
- c) Control Cables : Annexure – C
- d) Fire Survival Cables : Annexure – D
- e) Flexible Trailing cable : Annexure – E

1.03.00 All relevant drawings, data and instruction manuals

2.00.00 CODES & STANDARDS

2.01.00 All cable and materials shall be designed, manufactured and tested in accordance with the latest applicable Indian Standards (IS) and IEC except where modified and/or supplemented by this specification.

2.02.00 Cable and material conforming to any other standard which ensures equal or better quality, may be accepted. In such case, copies of the English version of the standard adopted shall be submitted along with the bid.

2.03.00 The electrical installation shall meet the requirements of Indian Electricity Rules as amended upto date and relevant IS Code of Practice. In addition, other rules and regulations applicable to the work shall be followed.

3.00.00 DESIGN CRITERIA

3.01.00 Cables will be generally laid on ladder type trays or drawn through rigid PVC/GI /HDPE pipe/conduits. Cable tunnels shall be avoided as far as possible, except at locations where overhead trays are not possible, with prior approval of the Owner.

- 3.02.00 For continuous operation at specified rating, maximum conductor temperature shall be limited to the permissible value as per relevant standard and/or this specification which one is more stringent.
- 3.03.00 The insulation and sheath materials shall be resistant to oil, acid and alkali and shall be tough enough to withstand mechanical stresses during handling.
- 3.04.00 Armouring shall be single round wire of galvanized steel for multicore cables and aluminum for single core cable for power and control cables. For fire survival control cable, the armouring over inner sheath shall consist of single layer of wire / round galvanised steel wire as per IS 3975 amended upto date. For Fire survival power cable, Single core cables to be used in A.C. system, the armouring over inner sheath shall consist of single layer of round copper wire, for multi-core cables to be used in A.C. system and single core cables in D.C. System, the armouring over inner sheath shall consist of single layer of round galvanised steel wire.
- 3.05.00 The outer sheath shall have flame retardant low smoke halogen evolution (FRLSH) characteristics or fire survival characteristics as applicable and shall meet the requirements of additional tests specified for the purpose.
- 3.06.00 Core identification for multicore cable shall be provided by colour coding.
- 3.07.00 HT cables shall be manufactured by triple extrusion dry cured (CCV) process using pressurized nitrogen.

4.00.00 **SPECIFIC REQUIREMENTS**

4.01.00 **General Description**

All Cables shall be furnished in strict compliance with ratings and requirements and sizes as given in Annexures to this Specification.

4.02.00 **Drum Length and Tolerance**

The cables shall be supplied in non-returnable packing steel drum for 11 kV & 3.3 kV power cables, wooden drums for 1100V power and control cables, each containing minimum 500 meters length of larger sizes of cable unless specifically asked for. For smaller sizes of cables, each drum shall contain 1000 meters length of cable. Allowable tolerance on individual drum length is $\pm 5\%$.

4.03.00 **Non-Standard Length**

Non-standard lengths upto 5% of the total ordered quantity may be accepted. However the Contractor will be required to obtain approval before packing the Cables on drums. Non-standard lengths shall not be less than 100 metres in any case.

4.04.00 **Cable identification**

Cable identification shall be provided by embossing on every meter on the outer sheath the following :

- a) TSGENCO
- b) Manufacturer's name or trade mark
- c) Voltage grade
- d) Year of manufacture
- e) Type of insulation, e.g. XLPE/PVC/HR85/IE2 etc.
- f) No. of core and size of cables.
- g) Type of improved fire performance, e.g. FR/FRLSH/FS
- h) IS number

4.05.00 **Packing**

4.05.01 Cables shall be supplied in non returnable drums. The drums shall be of heavy construction. All wooden parts shall be manufactured from seasoned wood. All ferrous parts used shall be treated with suitable rust preventive finish or coating to avoid rusting during transit or storage. Wooden cable drum shall be treated by immersing in copper-nitrate solution.

4.05.02 Cable shall be wound and packed on drums in such a manner that it will be properly sealed and firmly secured to the drum. The ends of each length shall be sealed before shipment.

4.05.03 The cable drums should carry the following details in printed form:

- a) TSGENCO
- b) Manufacturer's name or trade make
- c) Type of cable & voltage grade
- d) Year of manufacture
- e) Type of insulation e.g. XLPE/HRPVC/IE2
- f) No. of core and size of cables
- g) Cable code e.g. FRLSH/FS
- h) Length of cable on drum
- i) No. of length on drum, if more than one
- j) Direction of rotation, by arrow
- k) Approx. gross mass.

- l) IS/IEC number and ISI mark

4.06.00 **Joints and Terminations**

Materials of construction for a joint/termination shall perfectly match with the dielectric chemical and physical characteristics of the associated cables. The material and design concepts shall incorporate a high degree of operating compatibility between the cable and joints. The protective outer covering (jacket) used on the joints/terminations shall have the same qualities as that of the cable outer sheath in terms of ambient/operating temperature withstand capability and resistance to hazardous environments and corrosive elements. Straight through joints and terminations for HT cables shall be heat shrinkable type.

4.07.00 **Selection Criteria**

- 4.07.01 a) HT and LT power cables shall be selected on the basis of current carrying capacity, short circuit rating and permissible voltage drop.

- b) While sizing power cables, following aspects shall be reckoned:

- i) Ground/Ambient Air temperature
- ii) Depth of Laying.
- iii) Power Cables touching each other.

- c) Cables, for circuit breaker controlled feeders, shall withstand the short circuit current for the fault clearing time 0.16 Sec. for outgoing feeder, 0.5 Sec. for Tie feeder and 1.0 Sec. for Incomer.

- d) HT cables shall be sized based on the following considerations:

Rated current of the equipment and ground/ambient temperature.

Touching/spacing of cable.

Laying on multi-tier racks, trench

Depth of laying.

The voltage drop of the cable , during motor starting condition , shall be limited to 15% and during full load running condition shall be limited to 3 % rated voltage. For BFP motor, the voltage drop during motor starting condition shall be limited to 20% and for Mill motor shall be limited to 10%. Other outgoing feeder / transformer feeder shall be limited to 3% rated voltage.

Short circuits withstand capability

- e) For fuse/MCCB/Breaker protected circuits the conductor size shall depend upon full load current subject to voltage drop limited to 3% during running of all feeders and 15% during starting for motor feeders. In addition, transformer regulation shall also be considered for loads fed from 415V PMCC. Incase of other out going line feeder voltage drop shall be limited to 3%.

- f) For loads fed from local panels, the total running voltage drop in cable from 415V PMCC to local panel and from local panel to individual motor shall be limited to 3% at full load motor current while the same during starting shall be limited to 15%.
- g) As per national electric code (NEC) current rating capacity of motor feeder/cables should be 125% of full load current.
- h) For welding receptacle, 3% running drop shall only be considered.

The minimum sizes of L.T cable to be chosen are as below:

AL - 16 mm² (3 core) & 16mm² (2 core) Cu - 2.5 mm²

4.07.02 Apart from above, consideration shall also be given to limit the cable to some standard sizes instead of using too many types.

4.07.03 The standard cable sizes, amp capacities, derating factors. as given in IS/IEC will be generally followed.

4.07.04 a) For breaker protected circuits minimum size of the cable shall be as follows:

1100V Power Cable : 240 Sq mm XLPE AL

3300V Power Cable : 185 Sq mm XLPE AL

11000V Power Cable : 240 Sq mm XLPE AL

b) For motor circuits the selection of size will be made ensuring that the cable shall withstand a short circuit fault directly following a second hot start.

4.07.05 For fuse/MCCB protected circuit, the conductor size will depend on full load current subject to voltage drop not exceeding 3%. For practical purposes, the minimum size chosen is as below :

a) Aluminium : 6 Sq mm.

b) Copper : 2.5 Sq mm.

4.07.06 All control cables shall be 2.5 Sq mm copper cable.

4.07.07 Multicore control cables will generally have spare conductor (s) in accordance with the following chart :

Conductors required	Cables
1 or 2	1-3/C
3 or 4	1-5/C
5 or 6	1-7/C
7 or 8	1-9/C

- | | | |
|--|----------|-----------------------------|
| | 9 or 10 | 1-12/C |
| | Above 10 | Two or more of above cables |
- 4.07.08 Separate cables for each type of following services/functions as applicable shall be used for each feeder. Same multicore cable using different services shall not be acceptable.
- a) Power.
 - b) Control, interlock and indication.
 - c) Metering and measuring.
 - d) Alarm and annunciation.
 - e) C.T. Cables.
 - f) V.T. Cables.
- 4.08.00 **Cable Identification**
- Cable identification shall be provided by embossing on the outer sheath the following :
- a) Manufacturer's name or trade mark
 - b) Manufacturer's name or trade mark
 - c) Voltage grade
 - d) Year of manufacture
 - e) Type of insulation, e.g. XLPE, HRPVC & IE2 etc.
 - f) No. of core & size of cables
 - g) Type of outer sheath e.g. FRLSH, FS etc.
- 4.09.00 Selected sizes of power and control cables are given in Annexure-G.
- 4.10.00 Fire Survival Cables shall be used for important auxiliaries / area as recommended in Standard Technical Specification by CEA for the following services. The fire survival time of these cables shall not be less than 3 hours at 750 deg. C.
- i. DC emergency lube oil pump
 - ii. DC hydrogen seal pump
 - iii. Turbine lube oil pump/barring gear
 - iv. DC emergency lighting for main building and service building
 - v. DC cables for battery to charger & DC distribution boards

- vi. Jacking oil pump
- vii. Emergency turbine trip in control room
- viii. Boiler Turbine : Generator inter trip which include the interconnection between
 - Boiler master fuel trip and turbine trip relays
 - Generator trip relays & turbine trip relays
 - Generator trip relays & generator breaker
 - Generator trip relays & field breaker
 - Generator trip relays & unit auxiliary transformer breaker
 - Incomer cables for DG board, emergency board, DC lighting board etc.

5.00.00 **TESTS**

5.01.00 **Shop Tests**

The Cables shall be subject to shop tests in accordance relevant IS/IEC standards to prove the design and general qualities of the Cables as below:

5.01.01 Routine tests on each drum of cables.

5.01.02 Acceptance Tests on 1 drum out of every 10 drums chosen at random for acceptance of the lot for every size.

5.01.03 Type test on each type and size of cable, inclusive of measurement of armour DC resistance of power cables on one drum out of every 10 drums of cable.

5.02.00 **Additional Tests**

Following additional acceptance tests shall also be performed on each type of cables having outer sheath with improved fire performance (category C1, Type FR/ Category C2, Type FRLSH)

5.02.01 Oxygen index test (both C1 & C2)

The Oxygen index shall not be less than 29.

5.02.02 Temperature Index Test (both C1 & C2)

The measured value of temperature index shall be 21 at a temperature of 250°C for FRLS cables and 350°C for FS cables

5.02.03 Flame Retardance test on single cable and on bunched cables (both C1 & C2)

After the test, there should be no visible damages on the test specimen within 300mm from its upper end.

After burning has ceased, the cables should be wiped clean and the charred or affected portion should not have reached a height exceeding 2.5 meter above the bottom edge of the burner, measured at the front and rear of the cable assembly. 3 Hours fire rating test shall be carried out for FS cable as per IEC-331

5.02.04 Halogen acid gas evolution test (for Category C2)

The level of HCL evolved shall not exceed 20 per cent by weight. HCL evolved shall not be exceed 2% for FS cable.

5.02.05 Smoke density test (for Category C2)

The cables shall meet the requirements of light transmission of minimum 40% after the test. Minimum transmission shall be 80% for FS cable.

5.02.06 Test for specific optical density of smoke

The cables shall meet the requirements of IS/IEC.

5.02.07 Test for rodent & termite repulsion property

The test shall be carried out to note the presence of rodent and termite repelling chemical in PVC compound. Normal procedure is that a few chippings of the PVC compound are slowly ignited in a porcelain dish or crucible in a muffle furnace at about 600°C. The resulting ignited ash is boiled with a little ammonium acetate solution (10%). A drop of aqueous sodium sulphide solution is placed on a thick filter paper and it is allowed to soak. The spot is touched with a drop of above extract. A black spot indicates the presence of anti-termite & rodent compound.

Flammability test shall be carried on finished cables as per following standards-

- a) Swedish Chimney test – SS: 424-14-75
- b) IEEE std.383 – 1974 latest
- c) IEC std. 332-1, 332-3 and IEC 331

6.00.00 **DRAWINGS, DATA & MANUALS**

6.01.00 Drawings, Data and Manuals shall be submitted with the bid and for approval/ reference and subsequent distribution after the issue of Letter of Intent in quantities and procedures as specified in General condition of contract and/or

6.02.00 **To be submitted with the Bid**

- a) Manufacturer's catalogues giving cable construction details and characteristics.

- b) Cable current ratings for different types of installation, inclusive of derating factors for ambient temperature, grouping etc.
- c) Write-up on Manufacturer's recommended method of splicing, jointing, termination etc. of the cables.
- d) Type test reports on 11 KV & 3.3 KV Power, LT FRLSH Power & control, FS power and control cables.
- e) Filled-up proposal particulars.

6.03.00 To be submitted for Owner/Purchaser's Approval and Distribution

All relevant drawings and data pertaining to the equipment like GTP, QAP, etc. shall be submitted by the Bidder for the approval of Owner/Owner's consultant. Also refer clause no. 1.19.02(u) of Section-I of Volume – V-A: Technical Specifications for Electrical Equipment & Accessories.

ANNEXURE-A

**RATINGS AND REQUIREMENTS
HV POWER CABLES (11 KV & 3.3 KV)**

- 1.0 11000/11000V & 3300/3300V grade 90⁰C continuous rating under normal condition and 250⁰C rating under short circuit condition heavy duty XLPE power cable suitable for use in 11000V/3300V non-effectively earthed system conforming to following requirement and in line with IS-7098, IS-8130, IS-5831 & IS-3975, manufactured by Triple Extrusion Dry Cure (CCV) process using pressurized Nitrogen.
- 1.1 Conductor : Stranded and compacted aluminium conductor of grade H2 & class 2 for all sizes, generally conforming to IS: 8130.
- 1.2 Conductor Screen : Extruded semi-conducting compound.
- 1.3 Insulation : Extruded cross linked polyethylene (XLPE) conforming to IS: 7098 (Part-2)
- 1.4 Insulation Screen : Extruded semi-conducting compound with a layer of non-magnetic metallic tape. For single core armoured cables, the armouring shall constitute the metallic part of screening. The semi-conducting tape shall be easily strippable.
- 1.5 Core Identification : By coloured strips applied on (For three core cables) cores.
- 1.6 Inner Sheath : Extruded HRPVC/FRLS compound conforming to type ST2 of IS: 5831 for three core cables. Single core cables shall have inner sheath. Filler material shall also be of type ST2 PVC.
- 1.7 Armour : Galvanised single round steel wire armour for twin and multicore cables.

Non-magnetic hard drawn aluminum single round wire conforming to H4 of IS-8130 latest for single core cables
- 1.8 Overall Sheath : Extruded FRLSH HRPVC compound conforming to type ST2 of IS: 5831.
- 1.9 Drum : Steel Drum

ANNEXURE-B

**RATINGS AND REQUIREMENTS
LV POWER CABLES [1.1KV (XLPE TYPE)]**

- 1.0 1100 V grade, 90°C continuous rating under normal condition and 250°C under short circuit condition rating, XLPE heavy duty, power cable conforming to following requirement and in line with IS 7098 Part-I. IS 8130 & IS 5831 and IS 3975.
- 1.1 Conductor : Stranded and compacted plain aluminium of grade H2 and class 2 stranded, high conductivity annealed plain copper for cable sizes upto 2.5 mm² conforming to IS:8130.
- 1.2 Insulation : Extruded cross-linked polyethylene (XLPE) conforming to IS: 7098 (Part-1)
- 1.3 Core Identification : By color coding
- 1.4 Inner Sheath : Extruded HRPVC FRLS compound conforming to type ST2 of IS: 5831 for multicore cable. Single core cables shall have no inner sheath. Filler shall be of same material as of inner sheath i.e. ST2
- 1.5 Armour : Galvanized single round steel wire armour for twin and multicore cables.

Non-magnetic hard drawn aluminum single round wire conforming to H4 of IS-8130 latest for single core cables
- 1.6 Overall Sheath : Extruded FRLSH HRPVC compound conforming to type ST2 of IS: 5831.
- 1.7 Drum : Conforming to IS-10418 (Wooden drum)

ANNEXURE-C

**RATINGS AND REQUIREMENTS
CONTROL CABLES**

- 1.0 1100 V grade 85°C continuous rating under normal condition and 160°C under short circuit condition rating HRPVC Control cable (YWY) conforming to following requirement and in line with IS:1554, IS:8130, IS:5831 and IS:3975.
- 1.1 Conductor : Stranded, non-compacted & circular, high conductivity annealed plain copper, generally conforming to IS: 8130.
- 1.2 Insulation : Extruded HRPVC type-C compound conforming to IS: 5831. The minimum volume resistivity of insulation shall be 3.5×10^{14} ohm-cm at 27°C and 3.5×10^{11} OHM-CM at 85°C.
- 1.3 Core Identification : By color coding and numbering at interval of 100mm or less
- 1.4 Inner sheath : Extruded HRPVC compound conforming to type ST2 FRLS of IS: 5831 for multicore cables. Single core cables shall have no inner sheath. Filler shall be of same material as of inner sheath i.e. ST2.
- 1.5 Armour : Galvanised single round steel wire for twin and multicore cables.
- 1.6 Overall sheath : Extruded FRLSH HRPVC compound conforming to type ST2 of IS: 5831.
- 1.7 Drum : Conforming to IS: 10418 (Wooden drum)

ANNEXURE-D

RATINGS AND REQUIREMENTS (1.1KV GRADE COPPER CONDUCTOR FS POWER CABLES)

1100 V, copper conductor, heat resisting insulation, extruded inner sheath of low smoke and very low halogen content fire resisting material, single layer of copper wire armour for single core/ single layer of round galvanised steel wire for multicore, outer sheath of low smoke and very low halogen content fire resistant material, suitable for minimum temperature of 750 deg.C for 3 hours. The cables shall be in compliance with IEC-60331, Part 11.

RATINGS AND REQUIREMENTS (1.1KV GRADE COPPER CONDUCTOR FS CONTROL CABLES)

1100 V, copper conductor, heat resisting insulation, extruded inner sheath of low smoke and very low halogen content fire resisting material, single layer of copper wire armour for single core/ single layer of round galvanised steel wire for multicore, outer sheath of low smoke and very low halogen content fire resistant material, suitable for minimum temperature of 750 deg.C for 3 hours. The cables shall be in compliance with IEC-60331, Part 11.

ANNEXURE-E

**RATINGS AND REQUIREMENTS
FLEXIBLE TRAILING CABLES**

i) 3300 V Unearthed Grade

Flexible trailing cable, annealed plain copper conductor, Class-5 of IS-8130, insulated with EPR, conductor and insulation shielded with EPR, cores screened with ATC wire braiding, cores laid up, HD CSP inner sheathed, proof cotton taped and FRLS HD CSP sheathed overall, conforming to IS:9968. Alternatively PCP sheathing may be acceptable.

ii) 1100 V Grade

1100 V Grade trailing cable shall be plain copper of Class-5 of IS-8130, heat resistant elastomeric compound based on EPR insulation, inner sheath of heat resistant elastomeric compound PCP sheath, nylon cord reinforcement and heat resistant, oil resistant and flame retardant heavy duty elastomeric compound FRLS CSP outer sheath.

ANNEXURE-F

CABLE SIZES

Following sizes are given as a general guideline. Standard sizes as per IEC/IS shall be adopted.

SI. No.	Cable Size	Conductor	Insulation
1.0	H. T. CABLES (11kV)		
1.1	1 core 1000 sq.mm	AL	XLPE (FRLS)
1.1	1 core 630 Sq.mm	AL	XLPE (FRLS)
1.2	3 core 400 Sq.mm	AL	XLPE (FRLS)
1.3	3 core 240 Sq.mm	AL	XLPE (FRLS)
1.4	1 core 70 Sq.mm	AL	XLPE (FRLS)
1.0	H. T. CABLES (3.3kV)		
1.1	1 core 630 Sq.mm	AL	XLPE (FRLS)
1.2	3 core 300 Sq.mm	AL	XLPE (FRLS)
1.3	3 core 240 Sq.mm	AL	XLPE (FRLS)
1.4	3 core 185 Sq.mm	AL	XLPE (FRLS)
1.5	1 core 70 Sq.mm	AL	XLPE (FRLS)
2.0	L. T. POWER CABLES		
2.1	3 core 2.5 Sq.mm	CU	XLPE (FRLS)
2.2	2 core 16 Sq.mm	AL	XLPE (FRLS)
2.3	3 core 16 Sq.mm	AL	XLPE (FRLS)
2.4	4 core 16 Sq.mm	AL	XLPE (FRLS)
2.5	2 core 35 Sq.mm	AL	XLPE (FRLS)
2.6	3 core 35 Sq.mm	AL	XLPE (FRLS)
2.7	4 core 35 Sq.mm	AL	XLPE (FRLS)
2.8	3 core 70 Sq.mm	AL	XLPE (FRLS)

Sl. No.	Cable Size	Conductor	Insulation
2.9	3.1/2 core 70 Sq.mm	AL	XLPE (FRLS)
2.10	3 core 95 Sq.mm	AL	XLPE (FRLS)
2.11	3.1/2 core 95 Sq.mm	AL	XLPE (FRLS)
2.12	3 core 185 Sq.mm	AL	XLPE (FRLS)
2.13	3.1/2 core 185 Sq.mm	AL	XLPE (FRLS)
2.14	3 core 240 Sq.mm	AL	XLPE (FRLS)
2.15	3.1/2 core 240 Sq.mm	AL	XLPE (FRLS)
2.16	3 core 300 Sq.mm	AL	XLPE (FRLS)
2.17	3.1/2 core 300 Sq.mm	AL	XLPE (FRLS)
2.18	1 core 630 Sq.mm	AL	XLPE (FRLS)
3.0	CONTROL CABLE		
3.1	2 core 2.5 Sq.mm	CU	HRPVC (FRLS)
3.2	3 core 2.5 Sq.mm	CU	HRPVC (FRLS)
3.3	5 core 2.5 Sq.mm	CU	HRPVC (FRLS)
3.4	7 core 2.5 Sq.mm	CU	HRPVC (FRLS)
3.5	9 core 2.5 Sq.mm	CU	HRPVC (FRLS)
3.6	12 core 2.5 Sq.mm	CU	HRPVC (FRLS)
3.7	20 core 2.5 Sq.mm	CU	HRPVC (FRLS)
4.0	FS POWER CABLES		
4.1	3 core 2.5 Sq.mm	CU	EPR
4.2	2 core 16 Sq.mm	CU	EPR
4.3	3 core 16 Sq.mm	CU	EPR
4.4	4 core 16 Sq.mm	CU	EPR
4.5	2 core 35 Sq.mm	CU	EPR

SI. No.	Cable Size	Conductor	Insulation
4.6	3 core 35 Sq.mm	CU	EPR
4.7	4 core 35 Sq.mm	CU	EPR
4.8	3 core 95 Sq.mm	CU	EPR
4.9	3.1/2 core 95 Sq.mm	CU	EPR
5.0	FS CONTROL CABLE		
5.1	2 core 2.5 Sq.mm	CU	EPR
5.2	3 core 2.5 Sq.mm	CU	EPR
5.3	5 core 2.5 Sq.mm	CU	EPR
5.4	7 core 2.5 Sq.mm	CU	EPR
5.5	9 core 2.5 Sq.mm	CU	EPR
5.6	12 core 2.5 Sq.mm	CU	EPR

VOLUME: V-A

SECTION-VII

TECHNICAL SPECIFICATION
FOR
415V PMCC/MCC, 415V ACDB AND 220V DCDB

CONTENTS

CLAUSE NO.	DESCRIPTION
1.00.00	SCOPE OF SUPPLY
2.00.00	CODES AND STANDARDS
3.00.00	DESIGN CRITERIA
4.00.00	SPECIFIC REQUIREMENTS
5.00.00	TESTS
6.00.00	DRAWINGS, DATA AND MANUALS

ATTACHMENTS

ANNEXURE-A	RATINGS AND REQUIREMENTS
ANNEXURE-B	PROTECTIONS
ANNEXURE-C	FITTINGS & ACCESSORIES
ANNEXURE-D	BUS TRANSFER SCHEME FOR PMCC

DRAWINGS

TYPICAL SINGLE LINE DIAGRAM
TYPICAL CONTROL SCHEMATIC

VOLUME :V-A

SECTION-VII

**TECHNICAL SPECIFICATION
FOR
415V PMCC/MCC, 415V ACDB AND 220V DCDB**

1.00.00 SCOPE OF SUPPLY

1.01.01 Requisite nos. of following equipment shall be furnished with all accessories :-

- a. Power cum Motor Control Centre (PMCC)
- b. Motor Control Centres (MCC)
- b. A.C. Distribution Board (DB)
- c. D.C. Distribution Board (DB)
- d. D.C. Starters
- e. Lockout Switches
- f. A.C./D.C. fuse boards

1.01.02 The base channel frame with hardware and lifting angles.

1.01.03 One set of special tools and tackles.

1.01.04 Set of accessories as listed below :

- a) Breaker lifting and handling trolley.
- b) Test cabinet with coupling cables for testing the breaker in drawout position.
- c) Racking in/out handle for breakers.

1.01.05 12kV rubber mats shall be provided both at front and rear of LT Switchgear.

1.01.06 Mandatory Spare parts.

1.01.07 All relevant drawings, data and instruction manuals.

2.00.00 CODES AND STANDARDS

2.01.01 All equipment and materials shall be designed, manufactured and tested in accordance with the latest applicable Indian Standards (IS) and IEC except where modified and/or supplemented by this specification.

2.01.02 Equipment and material conforming to any other international standard which ensures equal or better quality, may be accepted. In such case, copies of the English version of the standard adopted shall be submitted along with the bid.

2.01.03 The electrical installation shall meet the requirements of Indian Electricity Rules as amended upto date and relevant IS Code of Practice. In addition, other rules and regulations applicable to the work shall be followed.

- 3.00.00 **DESIGN CRITERIA**
- 3.01.00 The PMCCs/MCCs/DBs will be used to provide power, control and protection for 415/240V A.C. and 220V D.C. auxiliary services (Motors & Feeders) of generating units.
- 3.02.00 Duty involves direct-on-line starting of large squirrel cage motors below 175kW. The starting current varies from 6 to 8 times rated current at very low power factor.
- 3.03.00 The equipment will be located in a hot, humid and tropical atmosphere, highly polluted at places with coal dust and/or fly ash.
- 3.04.00 For continuous operation at specified ratings, the temperature rise of various equipment/components shall be limited to the permissible values stipulated in relevant standards and/or this specification.
- 3.05.00 Equipment ratings and quantities are detailed in the enclosed drawings and annexure. Equipment shall be furnished in strict compliance with the same.
- 3.06.00 All equipment and components thereof shall be capable of withstanding the mechanical forces and thermal stresses of the short-circuit currents without any damage or deterioration of the materials.
- 3.07.00 The PMCCs/ MCCs / DBs shall have two incomers and one bus-coupler. In addition to electrical interlocks, mechanical castle key interlock shall be provided between the two incomers and the bus-coupler so that any two of the three may be closed at a time.
- 3.08.00 Busbars of PMCCs shall be sized to carry continuously the associated transformer secondary current plus a 20% margin.

Busbars of MCC/DBs shall be sized to carry continuously the total running load of MCC/DB plus a 20% margin.
- 3.09.00 In cubicle of incomers & bus section breakers/MCCBs shall be identical to the associated busbar rating.
- 3.10.00 For continuous operation at specified ratings, the temperature rise of various equipment/components shall be limited to the permissible values specified in relevant standards and/or this specification.
- 3.11.00 Circuit breakers shall not produce any harmful over voltage during switching off of induction motors. If required, surge protective devices shall be included in the scope of supply to limit over voltages.
- 3.12.00 Incomers, Bus-couplers & outgoing feeders rated upto & including 630A shall be MCCB controlled. Above 630A all incomers, Bus-couplers & outgoing Feeders shall be ACB controlled. For critical loads ACB controlled feeders shall be provided which will be decided during detail engineering.
- 3.13.00 All motor rated 110kW & above, below 175kW shall be ACB controlled. Motor rated upto 110kW shall be contactor operated.

- 3.14.00 MCC & PMCC shall have sufficient number of spare modules (at least 20% of various sizes used with a minimum of 1 no. for each rating and type).
- 3.15.00 Outgoing feeders of PMCC shall be limited to minimum number of different sizes so that max. standardization is achieved from MCCB & contactor size point of view.
- 3.16.00 Incomers & bus section breakers of PMCCs/MCCs shall have provisions for remote operation from control room.
- 3.17.00 All breaker operated motor feeder shall be supplied from PMCC.
- 3.18.00 One no. Normal/Emergency switchgear to cater power supply to important emergency load / motors for safe shut-down of unit including 220V battery chargers shall be provided for each unit. The main incoming supply shall be from 415V unit service switchgear. When main incoming supply fails, reserve incoming supply shall be switched ON automatically from 415V station service switchgear. In case of total failure of AC supply of the power station, the supply from DG shall be switched ON automatically.
- 3.19.00 Each switchgear shall be provided with two bus sections, two incomer and a bus coupler rated for 100% of the loads connected to the switchgear.
- 3.20.00 For each auxiliary or load, one feeder shall be provided except for the following cases:

One feeder for a maximum 2 nos. isolator motor operating mechanism.
- 3.21.00 The switchgears shall be provided with suitable number and type of outgoing feeders for the respective auxiliary loads of the system/area, power supply feeders to various panels, lighting transformer, space heating panels, control cabinets and all other loads encountered in the plant. In addition, following feeders shall be provided in each bus section of each switchgear.
- a) Bus VT module: One (1) no.
 - b) Switchgear test supply module: One (1) no.
 - c) 240V, 1 phase essential supply module with five nos. 1 phase outlets: One (1) no.
Necessary 415V/240V dry type transformer shall be provided.
 - d) Alarm module for common alarm for outgoing feeder fault: One (1) no.
 - e) DC supply alarm module for incomer, bus coupler fault: One (1) no.
- 3.22.00 Each feeder shall be provided with two nos. interposing relays for start & stop. These interposing relays shall be located in separate IPR panel described under C&I specification.

- 4.00.00 **SPECIFIC REQUIREMENTS**
- 4.01.00 **Construction**
- 4.01.01 PMCC / MCC / DB shall be indoor, metal-clad, air insulated and floor mounting type. All MCCs shall be fully draw out type and DBs shall be fixed type. ACB modules of PMCCs/MCCs shall be fully drawout type. MCCB / Switch Fuse modules shall also be fully drawout type. The design and construction shall be such as to allow extension at either end.
- 4.01.02 All PMCC/MCC shall be of double front construction.
- 4.01.03 PMCC /MCC/DB enclosure shall be dust and splash proof, conforming to a degree of protection IP-54. All switchboard frames and load bearing members shall be fabricated using suitable mild steel structural sections or pressed and shaped cold rolled sheet steel of thickness 2.0mm. Frames shall be enclosed in cold rolled sheet steel of thickness 1.6 mm. Doors and covers shall also be of cold rolled sheet steel thickness 1.6 mm. Stiffeners shall be provided wherever necessary. The gland plate thickness shall be 3.0 mm for hot/cold rolled sheet steel and 4.0 mm for non-magnetic material.
- 4.01.04 PMCC / MCC / DB assembly shall comprise a continuous line up of dead front, free-standing vertical sections, housing the control modules in multi tier formation.
- 4.01.05 The design shall be fully compartmentalized with metal/insulating partitions between compartments. The working height shall be limited within 750 mm to 1800 mm from floor level.
- 4.01.06 Each control module shall be housed in a separate compartment, complete with an individual front access door having sufficient opening with concealed type hinges. Each vertical section shall have a removal back cover. All doors and covers shall be gasketed.
- 4.01.07 All push buttons, lamps, indicating instruments shall be flush / semi-flush mounted on respective module compartment.
- 4.01.08 A full height vertical cable chamber with cable supports shall be provided in each section to facilitate unit wiring. The chamber shall be liberally sized to accommodate all cables and shall have removable cover at the front for access.
- 4.01.09 A horizontal wireway, extending the entire length, shall be provided at the top of each PMCC / MCC / DB for inter panel wiring.
- 4.01.10 The width of the cable alley shall not be less than 250 mm.
- 4.02.00 **Bus and Bus Taps**
- 4.02.01 All PMCCs/MCCs/DBs shall be provided with three phase & neutral bus bars . All DCDBs shall be provided with two busbars. All busbar compartments shall be completely enclosed.

- 4.02.02 The main buses and connections shall be of high conductivity Aluminium / Aluminium alloy, sized for specified current ratings with maximum temperature limited to 85°C (i.e., 35°C rise over 50°C ambient).
- 4.02.03 Vertical busbars shall be designed for minimum current rating of 200A. Separate vertical busbars shall be provided for each vertical panel.
- 4.02.04 All bus connections shall be silver plated. Adequate contact pressure shall be ensured by means of two-bolt connection with plain and spring washers and locknuts.
- Bimetallic connector shall be furnished for connection between dissimilar metals.
- 4.02.05 Busbars and connections shall be fully insulated for working voltage with adequate phase/ground clearances. Insulating sleeves for busbars and shrouds for joints and tap-off points shall be provided.
- Bus insulators shall be flame retardant, non-hygroscopic track-resistant type with high creepage surface.
- 4.02.06 Busbars shall be supported and braced to withstand the stresses due to maximum short circuit current and also to take care of any thermal expansion.
- 4.02.07 Busbars shall be colour coded for easy identification and so located that the sequence R-Y-B shall be from left to right, top to bottom or front to rear when viewed from the front of the assembly.
- 4.03.00 **Control Modules**
- 4.03.01 Draw-out type control module shall have self-aligning power/control disconnects. All disconnects shall be silver plated to ensure good contacts.
- 4.03.02 The design shall be such as to permit easy withdrawal/reinsertion of the unit with guide rails to ensure correct alignment.
- 4.03.03 Control Module shall house the control components for a circuit such as switch fuse / MCCB, contactors, relays, push buttons, lamps etc. as per requirement of the control circuit.
- 4.03.04 The equipment layout shall provide sufficient working space in between the components and subject to Owner's approval.
- 4.03.05 Various module/compartments sizes shall be multiple of one basic unit to facilitate modifications at site. Suitable provision for this purpose should also be incorporated in the vertical bus bars.
- 4.03.06 Draw-out type control modules of same size and type shall be electrically and physically interchangeable.
- 4.04.00 **Air Circuit Breaker**
- 4.04.01 Circuit breaker shall be provided on the incomer having minimum interrupting capacity equal to the 50kA(r.m.s) fault level.

- 4.04.02 Circuit breaker shall be three pole, single throw, air-break type with independent manual spring closing, trip-free mechanism and shunt trip. However Incomer breaker shall be four pole type.
- 4.04.03 Circuit breaker shall be draw-out type, having service, test & isolated position with positive indication for each position.
- 4.04.04 Circuit breakers of identical rating shall be physically and electrically interchangeable.
- 4.04.05 Each breaker shall be provided with microprocessor based protection unit having three overload protection with adjustable current and time, three short circuit protection with adjustable current and time and three instantaneous short circuit protection. The operating characteristic shall be suitable for co-ordination with down-stream fuses.
- 4.04.06 Circuit breakers shall be provided with motor wound spring charging mechanism. Spring charging shall take place automatically after each breaker closing operation. One open-close-open operation of the circuit breaker shall be possible after failure of power supply to the motor. In addition, facility for manual charging of spring shall be provided.
- 4.04.07 Mechanical safety interlock shall be provided to prevent the circuit breaker from being racked in or out of the service position when the breaker is closed. It shall not be possible to open the circuit breaker door cubicle unless the breaker is in 'OFF' position.
- 4.04.08 Automatic safety shutters shall be provided to cover up the stationary disconnects when the breaker is withdrawn.
- 4.04.09 Each breaker shall be provided with an emergency manual trip, mechanical ON-OFF indicator, an operation counter and spring mechanism charge/discharge indicator, and electrical anti-pumping feature.
- 4.04.10 In addition to the auxiliary contacts required for normal breaker operation and indication, each breaker shall be provided with the following for interlocking purpose :-
- a. Position/Cell switch with 4 NO + 4 NC contacts.
 - b. Auxiliary switch, with minimum 6NO + 6NC contacts,
- 4.04.11 Spring charge limit switch shall be provided for breakers with motor wound spring charging mechanism. These limit switches shall be provided with minimum 2NO + 2NC contact.
- 4.04.12 Limit/auxiliary switches shall be convertible type, that is, suitable for changing N.O. contact to N.C. and vice-versa.
- 4.04.13 Each breakers operated feeder shall be provided with protective devices as specified in Annexure–B.

- 4.05.00 **Switches**
- 4.05.01 Switches shall be triple pole, air break, AC23 motor duty for motor feeders and AC22 heavy duty for other feeders.
- Motors duty switches shall be capable of safely making and breaking the locked rotor current of the associated motor circuit.
- 4.05.02 The switch shall have a quick-make, quick-break mechanism operated by a suitable external handle, complete with position indicator. This handle shall have provision for padlocking in ON and OFF position.
- 4.05.03 The compartment door shall be interlocked mechanically with the switch such that the door cannot be opened unless the switch is in OFF position. Means shall be provided for releasing this interlock at any time.
- 4.05.04 Switches shall be capable of withstanding the let-through fault current of back-up fuses or circuit breakers.
- 4.05.05 Wherever two incoming switches and one bus-section switch are provided for an assembly, these shall be mechanically/key interlocked to ensure that only two out of the three can be closed at time.
- Wherever two incoming switches are provided for an assembly, these shall be mechanically/key interlocked to ensure that one of the two can be closed at time.
- 4.05.06 All incoming and outgoing feeders shall be provided with bolted disconnect link for isolation of neutral if necessary.
- 4.06.00 **Fuses**
- 4.06.01 Fuses shall be HRC, preferably link type, with a minimum interrupting capacity equal to the short circuit current of the LT system. Fuses shall be mounted on insulated fuse carriers, which are mounted on fuse bases. Wherever it is not possible to mount fuses on carriers, fuses shall be directly mounted on plug-in type of base. In such cases, one set of insulated fuse pulling handles shall be supplied with each board.
- 4.06.02 Fuses shall be furnished complete with fuse bases and fittings of such design as to permit easy and safe replacement of fuse element.
- Visible indication shall be provided on blowing of the fuse.
- 4.06.03 Motor fuse characteristics and ratings shall be chosen to ride over starting period without blowing. The fuse on incoming feeder wherever provided, shall be chosen to provide discrimination with motor/feeder fuses.
- 4.07.00 **Moulded Case Circuit Breaker (MCCB)**
- 4.07.01 The MCCBs shall be of drawout type with trip-free operating mechanism of quick make & quick break type. Each MCCB shall be equipped with thermal release for thermal overload and magnetic release for short circuit protection on each pole.

- 4.07.02 MCCBs / MPCBs shall be suitable for manual closing and opening and also automatic trip on overload and short circuit. MCCB shall have intermediate position to indicate trip condition.
- 4.07.03 The MCCBs shall be provided with mechanical ON-OFF indicator at the front panel. The MCCB handles, after the breaker tripped due to faults, shall occupy a mean position indicating trip condition.
- 4.07.04 The compartment door shall be interlocked mechanically with the MCCB such that the door cannot be opened unless the MCCB is in OFF position. Means shall be provided for releasing this interlock at any time.
- 4.07.05 All feeders of PMCC / MCC rated up to & including 630 Amp shall be provided with MCCB. Air circuit breaker shall be provided for feeders rated above 630 Amp. For critical loads ACB controlled feeders shall be provided which will be decided during detailed engineering.
- 4.07.06 Motors rating above 110 KW will be operated by Air circuit breaker and protected by consolidated numerical motor protection relay.
- 4.08.00 **A.C. Starter**
- 4.08.01 Contactors
- a. The contactors shall be three pole, air break type designed for duty class III - Category AC3 (for unidirectional motor) with non-bouncing silver/ silver alloy contacts. Contacts for reversible motors will be of AC4 duty.
 - b. Each contactor shall be provided with minimum two (2) normally open and two (2) normally closed auxiliary contacts rated 10 A at 240V A.C.
 - c. Reversing contacts shall be electrically and mechanically interlocked.
 - d. Contactors with delayed dropout feature shall be provided for some essential auxiliaries. These contactors shall not dropout on power failure if the voltage is restored within 3 seconds.
- 4.08.02 **Protection**
- a. Thermal overload relays shall be three element, positive acting, ambient temperature compensated with adjustable settings.
 - b. Single phase preventor relay shall be provided, preferably as an inbuilt feature of thermal overload relay.
 - c. Relays shall be manual reset type with two changeover potential-free contacts. Resetting of relays shall be possible with compartment door closed. Colour of the resetting button shall be BLACK.
 - d. Relays may be direct acting or C.T. operated, depending on current rating. C.T.s shall be included in the scope of supply.
 - e. Motor starters shall have type '2' co-ordination according to IEC 947-4.

- f. Earth fault relays with adjustable settings and time delays fed from core balance CT shall be provided.
- g. Numerical / Digital Motor protection relay with short circuit, over load, earth fault, locked rotor and unbalance (NPS) load protection functions shall be provided for motor rated above 90 kW.

4.09.00 **Control Transformer**

4.09.01 LT Switchboard control supply

The Bidder shall provide one (1) no. adequately rated 415V/110V Control Transformer in each bus section with necessary taps and auto changeover facility for providing control power supply to various modules of the board, except motor feeders. Each motor feeder shall be provided with 415/110V control transformer of adequate capacity (min. 75VA) for control supply to such module. The sizing of control transformer shall be carried out by the Bidder considering the actual load of power contactors, auxiliary contactors, indicating lamps and other equipment in the module circuit. An additional load of 15watts shall be considered for each module for remote auxiliary relays and lamps to be connected in the control circuit of modules. Bidder shall also ensure that control transformer are adequately designed for meeting the momentary loading requirements and the voltage drop during this condition shall not be more than 5%. Each transformer shall be sized for catering to control supply of both bus sections.

4.09.02 LT Switchboard space heater supply

The Bidder shall provide one (1) no. adequately rated 415V/240V Control Transformer in each bus section with necessary taps and auto changeover facility for providing power supply to panel space heater, Motor space heater of motor rated 30 KW & above, Panel Illumination & Socket. The supply of these two (2) nos. control transformer are tapped from incoming supply of 415V PMCC/MCC before the incoming breaker. Incoming circuit to the space heater auxiliary bus shall be through isolating switch HRC fuse and neutral link of suitable rating. The supply of different modules shall be tapped individually from the auxiliary bus bars. Control supply healthy indication shall be provided. Each transformer shall be sized for catering to space heater supply of both bus sections.

4.10.00 **D.C. Starters**

4.10.01 D.C. Starter for emergency oil pump shall be fixed resistance type, designed to provide fast acceleration during starting.

4.10.02 DC starters shall be complete with switch-fuse units, contactors, resistors, relays, meters, push-buttons, lamps, etc.

4.10.03 Starters shall be furnished in totally enclosed floor-mounting, sheet steel cubicles complete with a hinged front access door. Minimum thickness of sheet steel shall be 2mm.

4.10.04 The cubicle enclosure shall provide dust and humidity protection, the degree of protection being not less than IP-54.

The resistor enclosure shall be provided with ventilating louvers and wire mesh guard and shall have a degree of protection IP-23.

4.10.05 Cubicle space heater shall be provided to maintain internal temperature above dew point. Heater shall be furnished with switch-fuse unit and thermostat control.

4.11.00 **Relays**

4.11.01 All incoming and bus-coupler circuits and circuit breaker operated outgoing feeders shall be provided with numerical relays. Breaker operated motor feeders shall be provided with numerical motor protection relay.

4.11.02 The numerical relays shall have provisions for interfacing with Plant DDCMIS / PLC.

4.11.03 Relays shall be of drawout design with built-in testing facilities. Small auxiliary relays may be in non-drawout execution.

4.11.04 All protective relays, auxiliary relays, and timers shall be provided with hand reset operation indicator (flag).

4.11.05 Relays shall be rated for operation on 110V secondary voltage and 5 A or 1 A. Number and rating of relay contacts shall suit the job requirements.

4.12.00 **Control and Indication**

4.12.01 Circuit breakers shall be wired up for local and remote operation. Each breaker cubicle shall be equipped with the following :

i) One (1) TEST-NORMAL-TRIAL selector switch with pistol grip handle and key interlock for breakers with motor wound spring charging mechanism.

ii) On-Off control switches shall have three positions (T-N-C) and shall be spring return to 'Neutral' from close and trip positions. They shall have two contacts closing in close position and two contacts closing in trip positions, and shall have Pistol Grip handles. Lost motion feature shall be provided wherever required.

iii) Following indicating lamps on the front of the compartment:

Breaker open	-	GREEN
Breaker closed	-	RED
Breaker tripped	-	AMBER
Spring charged	-	WHITE
Trip Ckt. Healthy	-	BLUE

Motor Space heater 'ON' for motor circuit - YELLOW

- 4.12.02 Push button shall be heavy duty, oil tight, push to actuate type with integral escutcheon plate marked with its function.
- 4.12.03 Each push button shall have minimum two (2) nos. normally open and two (2) nos. normally closed contacts rated 10 A at 240 V.
- 4.12.04 One (1) NORMAL-TRIAL selector switch shall be provided for all motor feeders.
- 4.12.05 Selectors switches shall be stay-put, rotary type with escutcheon plates marked to indicate the function and positions, and shall be lockable in each position. Selector switch contacts shall be rated for 10A at 240 V A.C.
- 4.12.06 Selector switches shall be provided with minimum three (3) contact blocks of 1 NO + 1 NC each.
- The exact requirements of contacts shall be decided by the Tenderers taking into account the scheme requirement and spares.
- 4.12.07 Lamps shall be clustered LED type with series resistor and coloured lens. Lens and lamps shall be replaceable from the front. Lamps shall be located just above the associated push button/control switch
- 4.12.08 The general scheme of connections for control, interlock and protection is shown in the enclosed drawings. Detailed requirements of individual circuits will be intimated later to the successful bidder, who shall develop and furnish the schemes accordingly.
- 4.13.00 **Meters**
- 4.13.01 All indicating instruments (96 x 96 mm) shall be switchboard type, with 250° scale, anti-glare glass and accuracy class of $\pm 2\%$ full scale. Each meter shall have zero adjuster on the front.
- 4.13.02 Motor ammeter shall be suitable to indicate starting current (6 to 8 times full load current) for DOL starting of motor.
- Motor ammeter shall be provided for motor rated 30 kW and above and for critical drives, to be finalized during detail engineering.
- 4.13.03 All incomers, tie feeders, circuit breaker operated motor feeders shall be provided with 3-phase multifunction meter with pulse output and communication port for interfacing with Plant DDCMIS / PLC.
- 4.13.04 Meter selector switches shall be maintained contact, stay-put type, with knob handle. Ammeter and voltmeter selector switches shall be four position type. Ammeter selector switches shall have made before break contacts, to prevent open circuiting of CT secondary.
- 4.14.00 **Current Transformer**
- 4.14.01 Current Transformer, shall be cast resin type rated 10 VA. All secondary connections shall be bought out to terminal blocks where wye or delta connection will be made.

- 4.14.02 Accuracy class of the current transformers shall be:
- a) Class PS for REF
 - b) Class 5P20 for other relaying.
 - c) Class 1.0 ISF < 5 for metering.
 - d) Class 0.5 ISF < 5 for metering (Incomer & Bus coupler of PMCC)
- Other CT particulars like ratio, burden, knee point, excitation current & secondary resistance shall be decided by the bidder.
- 4.14.03 CT secondary shall be rated for 1A for metering & either 5A or 1A for protection.
- 4.15.00 **Voltage Transformer**
- 4.15.01 Voltage transformers shall be cast-resin, drawout type and shall have an accuracy class of 1.0. Voltage transformer mounted on breaker carriage is not acceptable. For Incomer and bus coupler of PMCC accuracy class of voltage transformer shall be 0.5.
- 4.15.02 High voltage windings of voltage transformer shall be protected by current limiting fuses. The voltage transformer and fuses shall be completely disconnected and visibly grounded in fully draw out position.
- 4.15.03 Secondary winding MCBs, sized to prevent overload shall be installed in all ungrounded secondary leads. MCBs shall be suitably located to permit easy replacement while the switchgear/PMCC is energized.
- 4.15.04 Both primary side & secondary side fuse failure / voltage loss monitoring system of VT shall be provided.
- 4.16.00 **Transducers**
- 4.16.01 Transducer for conversion of AC electrical quantities such as voltage, current, KW etc. shall be supplied as required for remote connection to Plant DDCMIS / PLC. All transducers shall be dual output type.
- 4.16.02 The transducers for indicating type instruments shall be of very low burden type having 4-20 mA DC linear, galvanically isolated output, compatible with secondary instruments and Plant DDCMIS system.
- 4.17.00 **Secondary Wiring**
- 4.17.01 The PMCC/MCC/DB shall be fully wired at the factory to ensure proper functioning of control, protection and interlocking schemes.
- 4.17.02 Fuse and links shall be provided to permit individual circuit isolation from bus wires without disturbing other circuits. All spare contacts of relays, push buttons and other devices shall be wired upto terminal blocks.

- 4.17.03 Wiring shall be done with flexible, 1100V grade, fire resistance PVC insulated switchboard wires with stranded Copper conductors of 2.5 mm² for control & current circuits and 1.5 mm² for voltage circuits.
- 4.17.04 Each wire shall be identified, at both ends, with permanent markers bearing wire numbers as per Contractor's wiring diagrams.
- 4.17.05 Wire terminations shall be made with crimping type connector with insulating sleeves. Wires shall not be spliced between terminals. Separate colour code shall be used for AC & DC circuit wiring for easy identification.
- 4.18.00 **Terminal Blocks**
- 4.18.01 Terminal blocks shall be 1100V grade box-clamp type with marking strips similar to ELMEX 10 mm² or equal. Terminals for C.T. secondary leads shall have provision for shorting.
- 4.18.02 Terminal blocks used for interface with DDCMIS / PLC via termination cabinet shall be suitably sized to facilitate proper termination of interconnecting cables.
- 4.18.03 Not more than two wires shall be connected to any terminal. Spare terminals equal in number to 20% active terminals shall be furnished.
- 4.18.04 Terminal blocks shall be located to allow easy access. Wiring shall be so arranged that individual wires of an external cable can be connected to consecutive terminals.
- 4.19.00 **Cable Terminations**
- 4.19.01 PMCC shall be designed for cable entry from bottom. MCC/DB shall be designed for cable entry both from top and bottom. Actual configuration shall be intimated later sufficient space shall be provided for ease of termination and connection.
- 4.19.02 Power cables shall be 1100V, Copper/Aluminum conductor, XLPE insulated, armoured, FRLSH PVC overall sheathed.

Control cables shall be 1100V, PVC insulated, armoured, PVC overall sheathed with 2.5 mm² stranded Copper conductor.
- 4.19.03 All provisions and accessories shall be furnished for termination and connection of cables, including removable gland plates, cable supports, crimp type tinned Copper/Aluminium lugs, brass compression glands with tapered washer (Power Cables only) and Terminal blocks.
- 4.19.04 Sufficient space shall be provided between the lower most power cable termination and gland plate for easy cable connection.
- 4.20.00 **Bus Duct Connection**
- 4.20.01 Bus duct connections shall be furnished along with transition panel, if required. Unless mentioned otherwise bus duct connections shall generally be from the top.

- 4.20.02 All connecting bus work shall have the same continuous current rating as associated PMCC bus and shall be fully braced for the LT system short circuit current.
- 4.20.03 All provisions such as matching flange and other accessories shall be furnished for connection to bus duct.
- 4.21.00 **Ground Bus**
- 4.21.01 A Cu / Al ground bus rated to carry the maximum fault current, shall extend full length of the MCC/DB.
- 4.21.02 The ground bus shall be provided with two-bolt drilling with G.I. bolts & nuts at each end to receive 50 x 6 mm G.I. flats.
- 4.21.03 All stationary structures shall be directly connected to the ground bus for effective grounding.
- 4.21.04 The frame of draw out module shall be grounded at all times except when the power disconnects are separated by a safe distance.
- 4.21.05 All hinged doors shall be earthed through flexible copper braid wire.
- 4.22.00 **Nameplate**
- 4.22.01 Nameplate of approved design shall be provided for each control compartment and also at the top of each PMCC / MCC / DB.
- 4.22.02 The material of the name plate shall be anodized aluminium / lamicoide or approved equal, 3 mm thick, with white letter on black background. Name plates shall be minimum 20 x 75 mm for instrument / devices and 40 x 150 mm for panels.
- 4.22.03 Caution notice on suitable metal plate shall be affixed at the back of each vertical panel.
- 4.23.00 **Space Heater**
- 4.23.01 Panel and motor space heater shall be fed from separate AC auxiliary busbars running throughout the switchboard. The space heater bus shall be fed from control transformer described earlier. Suitable terminals shall also be provided to facilitate energisation of the control transformer from outside during long shutdown of the board.
- 4.23.02 Each vertical section of the PMCC / MCC / DB shall be furnished with thermostat controlled space heater and 5A, 5 pin plug socket.
- 4.23.03 In addition, motor feeders 30 KW and above shall be wired up for feeding motor space heater through starter auxiliary 'OFF' contacts.
- 4.23.04 Cubicle heater, Motor heater and plug socket circuit shall be provided with individual MCB/switch fuse units.

4.24.00 **A.C./D.C. Power Supplies**

4.24.01 Necessary 415V AC and 220V DC power supplies as required for control and service shall be arranged by the contractor. Single feeder shall be arranged for A.C. supply and duplicate feeder shall be arranged for D.C. supply.

4.24.02 Isolating switch fuse units shall be provided at each switchgear for the incoming supplies, 4-pole, single throw for A.C. and 2-pole, double throw for D.C. Molded case circuit breaker (MCCB) shall also be accepted as an alternative.

4.24.03 Bus-wires of adequate capacity shall be provided to distribute the incoming supplies to different cubicles. Isolating switch fuse units / MCCB shall be provided at each cubicle for A.C/D.C. supplies.

4.24.04 A.C. load shall be so distributed as to present a balanced loading on three-phase supply system.

4.25.00 **Tropical Protection**

All equipment, accessories and wiring shall have fungus protection, involving special treatment of insulation and metal against fungus, insects & corrosion.

Screens of corrosion resistant material shall be furnished on all ventilating louvers to prevent the entrance of insects.

4.26.00 **Painting**

4.26.01 All steel surfaces shall be sand blasted, grounded and pickled as required to produce a smooth, clean surface free of scale, grease & rust.

4.26.02 After cleaning, the surfaces shall be given a phosphate coating followed by two coats of high quality primer and stoved after each coat.

4.26.03 For paint shade of finish coat, refer clause no.1.16.00 of Section E1, Volume V-A.

4.26.04 Sufficient quantity of touch-up paint shall be furnished for application at site.

4.26.05 Caution notice plate shall be affixed at the back of each vertical panel.

5.00.00 **TESTS**

5.01.00 All equipment shall be completely assembled, wired, adjusted and tested at the factory as per the relevant standards.

5.02.00 **Routine Test**

The tests shall include but not necessarily be limited to the following :-

- a. Operation under simulated service condition to ensure accuracy of wiring, correctness of control scheme and proper functioning of the equipment.

- b. All wiring and current carrying part shall be given appropriate High Voltage Test.
- c. Primary current & voltages shall be applied to all instrument transformers.
- d. Routine test shall be carried out on all equipment such as circuit breakers, switch - fuse, contactors, relays, meters etc.

5.03.00 **Type Tests**

The type test certificates for the following tests carried out on an identical & similar type of switchgear shall be furnished. The date of tests shall be within the last five years.

- a. Temperature rise Test
- b. Short time current test on main circuit and earth circuit.
- c. Verification of making and breaking capacity.

Type test certificates of any equipment shall be furnished if so designed by the purchaser/ owner. Otherwise the equipment shall have to be type tested free of charge, to prove the design. Type test performed before five (5) years are not acceptable.

6.00.00 **DRAWINGS, DATA & MANUALS**

6.01.00 Drawings, Data & Manuals shall be submitted in triplicate with the bid and in quantities and procedures as specified in General Conditions of Contract and/or elsewhere in the specification for approval and subsequent distribution after the issue of 'Letter of Intent'.

6.02.00 **To be submitted with the bid :-**

- a. General arrangement drawing showing constructional features, space required in front for withdrawals, power & control cable entry points etc.
- b. Typical foundation plan
- c. Typical control schematic
- d. Bill of materials
- e. Type test reports on circuit breaker
- f. Technical leaflets on :-
 - i) Circuit breaker
 - ii) Switch-fuse units
 - iii) Contactors
 - iv) Relays, meters, push buttons, selector switches etc.
 - v) Glands/terminals blocks

6.03.00 **To be submitted for Owner / Purchaser's Approval and Distribution**

All relevant drawings and data pertaining to the equipment like GTP, GA drawing, foundation plan, BOM, control & schematics, QAP, etc. shall be submitted by the Bidder for approval of Owner/Owner's consultant. Also refer clause no. 1.19.02(u) of Section-I of Volume – V-A: Technical Specifications for Electrical Equipment & Accessories.

Other Feeder	:	AC22	DC22
5.0 A.C. / D.C. Power Supply			
Control Voltage for Circuit breaker	:	220V DC +10% to -15%	
Control voltage for MCCB modules	:	110V AC \pm 10%, 1Ph, 50Hz +3% to - 5%	
Service voltage	:	240V AC \pm 10%, 1Ph, 50Hz +3% to - 5%	

ANNEXURE-B

PROTECTIONS

- 1.0 All Protective relays shall be numerical type having communication facility with Plant DDCMIS system / PLC.
- 2.0 The minimum protections to be provided for different types of circuits are listed below:
 - a. Incoming Feeder & Bus-coupler with ACB:
 - 3 - inverse time O/C relays (51) for phase fault.
 - 1 - Inverse time O/C relay (51N) for Earth fault.
 - 3 - Under Voltage (27), Range : 40-80% with timer
 - b. Motor Feeder with ACB: (above 110 kW)
 - 1 - Composite Motor protection relay (99) for protection against
 - Thermal overload
 - Phase faults
 - Unbalance (negative sequence)
 - Locked rotor
 - Excessive Start-up time and Start-Stop.
 - Earth fault
 - c. Outgoing Feeder : with ACB
 - 3 - Inverse time O/C relays (51) for phase fault.
 - 1 - Inverse time O/C relay (51N) for Earth fault.
- 3.0 Apart from protection relays, each electrically operated breaker shall be provided with anti-pumping (94), trip annunciation (30), lockout (86) and trip circuit supervision (74) relays. Lockout relay shall be hand reset type.
- 4.0 Both primary side & secondary side fuse failure / voltage loss monitoring system of VT shall be provided..
- 5.0 For Auto-bus change-over as well as live bus change-over through synchronization refer enclosed Control Schematic drawings.
- 6.0 Each incomer shall be provided with three (3) nos. Bus Energised indicating lamps – Red/Yellow/Blue for each phase.

ANNEXURE-C

FITTINGS & ACCESSORIES

Each switchboard shall be furnished complete with fittings and accessories as listed below: -

1. Operating mechanism complete with all accessories, fittings and tripping coil and closing coil, pole discrepancy feature etc. as required.
2. Base frame and anchor bolts and nuts.
3. Auxiliary contacts and relays.
4. LOCAL/REMOTE Selector switch, TRIP/CLOSE Push Buttons.
5. Manual tripping devices with protective flap.
6. Mechanical ON-OFF indicator.
7. Operation counters.
8. Set of switch fuse units/MCCB for A.C. and D.C. supply.
9. Space heater with thermostat and ON-OFF switch.
10. Cubicle illumination lamp with ON-OFF switch.
11. 3 Pin 5A Socket with ON-OFF Switch.
12. Terminal blocks and internal wiring - lot as required.
13. Other standard accessories which are not specifically mentioned but supplied with breakers of similar type and rating for efficient and trouble-free operation.

14. Bimetallic terminal connectors.

ANNEXURE-D

BUS TRANSFER SCHEME FOR PMCC

1.0 The manual bus transfer shall be arranged in such a way that any of the following modes of operation is possible.

1.1 Manual Bus Transfer

a) Without voltage interruption

This means by allowing momentary parallel operation of two sources.

b) With voltage interruption

i) Slow Transfer

ii) Fast Transfer

NOTE : For CHP/AHP system 'Manual bus transfer without voltage interruption' and 'dead bus transfer with voltage interruption' shall be provided.

Synchronization of Incomer & Bus coupler for each of the 415V PMCC shall be implemented through PLC in CHP electrical cum control room building. Synchronization check relay, guard relay and auxiliary relay shall be provided in each PMCC. Synchroscope along with cut off switch, double voltmeter, double frequency meter shall be provided in the Main CHP electrical building cum control room. Separate synchronization switch and trip selector switch for each of the PMCC shall also be provided in the CHP electrical building cum control room.

VOLUME: V-A

SECTION-VIII

**TECHNICAL SPECIFICATION
FOR
LOCAL CONTROL BOARDS/PANELS,
LOCAL ISOLATING SWITCH UNITS
AND LOCAL PUSH BUTTON STATIONS**

CONTENT

CLAUSE NO.	DESCRIPTION
1.00.00	SCOPE OF SUPPLY
2.00.00	CODES AND STANDARDS
3.00.00	DESIGN CRITERIA
4.00.00	SPECIFIC REQUIREMENTS
5.00.00	TESTS
6.00.00	DRAWINGS, DATA AND MANUALS

ATTACHMENTS

ANNEXURE-A RATINGS AND REQUIREMENTS

ANNEXURE-B A.C/D.C POWER SUPPLY

ANNEXURE-C FUNCTIONAL REQUIREMENTS OF ANNUNCIATOR

ANNEXURE-D AREA WISE INDICATIVE LIST OF LOCAL CONTROL BOARDS/PANELS

ANNEXURE-E LOCAL CONTROL PANEL / LOCAL STARTER PANEL FOR COAL HANDLING PLANT

VOLUME: V-A

SECTION-VIII

**TECHNICAL SPECIFICATION
FOR
LOCAL CONTROL BOARDS/PANELS, LOCAL ISOLATING
SWITCH UNITS AND LOCAL PUSH BUTTON STATIONS**

1.00.00 SCOPE OF SUPPLY

1.01.00 The following equipment shall be furnished with all accessories:

- a) Complete set of Local Control Boards/Panels, an indicative list of which is given in Annexure-C
- b) Local Push Button Stations: As required
- c) Local Isolating Switch Units: As required

1.02.00 Furnishing, Mounting, and wiring of all equipments, devices and accessories

1.03.00 Floor Channel sill, vibration damping pad, and kick plates for all floor-mounted control boards/panels, complete with holding down bolts and nuts.

1.04.00 Mounting hardware for all control boards/panels, Local Push Button Stations, and Local Isolating Switch Units.

2.00.00 CODES AND STANDARDS

2.01.00 All equipment and materials shall be designed, manufactured and tested in accordance with the latest applicable Indian Standards (IS) and IEC except where modified and/or supplemented by this specification.

2.02.00 Equipment and material conforming to any other international standards, which ensure equal or better quality, may be accepted. In such case, copies of the English version of the standard adopted shall be submitted along with the bid.

2.03.00 The electrical installation shall meet the requirements of Indian Electricity Rules as amended up to date and relevant IS Code of Practice. In addition, other rules and regulations applicable to the work shall be followed.

3.00.00 DESIGN CRITERIA

3.01.00 The Local Control Boards/Panels will be used for controlling incomers/ bus-section/electrically operated radial breaker feeders of the associated PMCC/MCC. Necessary indications, meters, annunciators and mimic representation shall also be provided on these control boards/panels.

Local control of all drives shall be done from Process Control Boards/Panels, as described in respective sections of mechanical specification.

- The Local Control Boards/Panels shall have to be duly matched with the Process Control Boards/Panels.
- 3.02.00 Local Push Button (L.P.B.) stations will be used for controlling drives from local as required.
- 3.03.00 Local Isolating Switch (L.I.S) Units will be used for local isolation of power supply to various machines as required.
- 3.04.00 All equipment except L.I.S. Units and L.P.B stations, will be located in a clean but hot, humid, and tropical atmosphere. The L.I.S. Units and L.P.B. stations will be generally installed in a hot, humid, and tropical atmosphere, heavily polluted at places with fly ash and/or coal dust, and shall be suitable for outdoor service with degree of protection specified elsewhere in this specification.
- 3.05.00 All Control Boards/Panels, L.I.S. Units, and L.P.B. stations shall be liberally sized so as to provide spacious layout of equipment and devices with sufficient working space in between.
- 3.06.00 Adequate space/terminals shall be kept in the boards/panels for installing additional equipment in future.
- 3.07.00 For continuous operation at specified ratings, temperature rise of the various components/equipment shall be limited to the permissible values stipulated in the relevant standards and/or this specification.
- 3.08.00 All equipment/components thereof shall be capable of withstanding the mechanical forces and thermal stresses of the system short circuit current without any damage or deterioration of material.
- 3.09.00 Design, material selection, and workmanship shall be such as to present a neat appearance outside and inside with no welds, rivets, screws, or bolt heads apparent from the exterior surface of the boards/panels. All instrument cut-outs, mounting studs, and support brackets shall be accurately located.
- 4.00.00 **SPECIFIC REQUIREMENTS**
- 4.01.00 **Construction**
- 4.01.01 Local Control Boards/Panels
- a) Local Control Boards may consist of a number of vertical panels mounted side-by-side, in each case, they shall be bolted together to form a compact unit. Where two panels meet, the joints shall be smooth, close-fitting, and unobtrusive.
 - b) The control boards/panels shall be totally enclosed type, conforming to degree of protection IP-54 or better.
 - c) Generally, the local control boards/panels shall be free-standing, floor-mounted, dead-front assemblies. In some cases, however, wall-mounted type control boards/panels may also be accepted.

- d) Floor-mounted control boards/panels shall be assembled on channel/ angle base plates with anti-vibration mountings and stainless steel kick-plates.
- e) All switchboard/panels frames and load bearing members shall be fabricated using suitable mild steel structural sections or pressed and shaped cold rolled sheet steel of thickness 2.0mm. Frames shall be enclosed in cold rolled sheet steel of thickness 1.6 mm. Doors and covers shall also be of cold rolled sheet steel thickness 1.6 mm. Stiffeners shall be provided wherever necessary. The gland plate thickness shall be 3.0 mm for hot/cold rolled sheet steel and 4.0 mm for non-magnetic material.

The boards/panels shall have sufficient structural reinforcement to ensure a plane surface, to limit vibration, and to provide rigidity during shipment and installation.
- f) All floor-mounted panels shall have rear door.
- g) Doors shall have concealed type hinges and padlocking arrangement. Doors shall be grounded by flexible copper braid.
- h) All doors and removable covers shall be provided with neoprene rubber gaskets all round and latches sufficiently strong to hold them in alignment when closed.
- i) Working height of the panels shall be limited between 550 mm and 1800 mm above floor level.

4.01.02 Local Push Button Stations

- a) L.P.B. Stations shall be furnished in sheet steel enclosure of dust and vermin-proof, weather-proof, gasketed construction, suitable for outdoor use without canopy, and conforming to degree of protection IP-55 or better for indoor and IP-65 for outdoor.
- b) L.P.B. Stations shall be suitable for column/structure/wall mounting and shall be complete with push-buttons, terminal blocks, anodised aluminum inscription plate, two (2) nos. earthing terminals, removable gland plate along with crimp type tinned copper lugs and compression type glands for cable/conduit entry from top and bottom. The earthing terminals shall be suitable for connection to one (1) no. 8 SWG G.I. wire.
- c) L.P.B. Stations shall be of the following basic type and equipped with:
 - Type-A : One (1) START push-button and one (1) STOP push-button.
 - Type-B : One (1) OPEN push-button, one(1) CLOSE push-button, and one(1) STOP push-button.

- Type-C : Flame proof type as per IS-2148. one (1) START push-button and one(1) STOP push-button.
- Type-D : One (1) STOP Lock-out switch.
- Type-E : One (1) STOP Emergency PB.

Belt sway bridging Push Button shall be provided in the Local Push Button Station for all conveyor Drives.

Emergency Stop push button shall be provided in the Local Push Button Station for all HT motors.

Any other type of L.P.B. Station, if required, shall be subject to approval of the Purchaser.

- d) OPEN, CLOSE, and START push-buttons shall be spring return to normal type. STOP push-buttons shall have mushroom head actuator with press-to-latch and key-to-release feature.
- e) OPEN/START push buttons shall be GREEN, STOP push buttons shall be RED, and CLOSE buttons may be YELLOW.
- f) All push-buttons shall have a minimum of two (2) Normally-Open and two (2) Normally-Closed electrically separate contacts, rated minimum 10 A at operating voltage.
- g) Wiring shall be done with 1100V grade fire resistance PVC insulated stranded copper conductor of not less than 2.5 Sq.mm cross section. Each wire shall be identified at both ends by ferrules with wire designation.
- h) Terminals shall have provision for connecting at least two (2) nos. 2.5 sq.mm. Copper cable and shall be rated for carrying continuously minimum 10 A at 240V A.C. and 2 A at 220V D.C.

4.01.03 Local Isolating Switch Units

- a) L.I.S. Units shall be furnished in sheet steel enclosure of dust and vermin-proof, weather-proof, gasketed construction, suitable for outdoor use without canopy, and conforming to degree of protection IP-55 or better.
- b) L.I.S. Units shall be suitable for column/structure/wall mounting and shall be complete with load-break switch, terminal blocks, anodised aluminum inscription plate, two (2) nos. earthing pads, removable gland plate along with crimp type tinned copper lugs and compression type glands for cable/conduit entry from top and bottom. The earthing pads shall be suitable for connection to 25 x 3 mm G.S. flat
- c) Load-break switches shall be four-pole, air break, heavy-duty type. Duty class of load-break switches shall be AC-23 for motor feeders. Motor feeder switches shall be capable of safely breaking the locked rotor current of the associated motor circuit.

- d) Terminals shall be clip-on type, 10 sq.mm. minimum.

4.02.00 **Equipment Mounting**

4.02.01 All equipment shall be so mounted that removal and replacement may be accomplished individually without interruption of services to others. No equipment shall be mounted on panel door.

4.02.02 All equipment mounted inside the panels shall be so located that their terminals and adjustments are readily accessible for inspection or maintenance.

4.02.03 For Local Control Boards/Panels control components such as push buttons, indicating lamps, selector switches, indicating meters etc. shall be flush mounted on the front face of the board/panel while switch fuses, supervision relays (AC/DC) etc. shall be mounted inside.

4.03.00 **Name Plate**

4.03.01 Nameplates shall be furnished for each panel and for each instrument or device mounted on the panel. Each LPB Station shall also be provided with a nameplate.

4.03.02 The material of the nameplate shall be lamicaid or approved equal, 3 mm thick, with white letters on black background.

4.03.03 The nameplates shall be held by self tapping screws. The size of nameplate shall be approx. 20 mm x 75 mm for equipment and 40 mm x 150 mm for the panels. The size of the nameplate shall suit the overall dimensions of LPB station/L.I.S Unit.

4.03.04 Nameplates for panels shall be provided both on the front and on the rear and shall be according to final device/designation list.

4.03.05 Control and meter selection switches shall have integral nameplates. Nameplates for all other devices shall be located below the respective devices.

4.03.06 Instruments and devices mounted on the face of the panels shall also be identified on the rear with the instrument or device number. The number may be painted on or adjacent to the instrument or device case.

4.04.00 **Mimic Diagram**

4.04.01 Mimic diagram of electrical connections shall be furnished on the front face of all electrical control panels.

4.04.02 Mimic buses shall be at least 3 mm thick and 10 mm in width, made of suitably treated metal strips or approved equivalent and colour coded to denote different voltages.

4.04.03 The mimic representation, colour and size of diagram are subject to the approval of the Purchaser.

- 4.05.00 **Illumination, Space Heating and Receptacles**
- 4.05.01 Each panel shall be provided with interior fluorescent tube with door switch, space heater with thermostat and 5A, 5-pin receptacle with plug. Fifth pin of the socket shall be effectively grounded through the metallic structure.
- 4.05.02 Tube, heater and receptacle circuits shall be suitable for available A.C. supply and furnished with individual ON-OFF switch.
- 4.05.03 The lamp shall be located at the ceiling and guarded with protective cage. Space heater shall be located near the floor so as not to pose any hazard to service personnel.
- 4.06.00 **AC/DC Power Supply**
- 4.06.01 Necessary A.C. and D.C. supplies as required for control and service shall be arranged by the contractor. Single feeder shall be arranged for A.C supply and duplicate feeders shall be arranged for D.C supply.
- 4.06.02 Isolating switch fuse units shall be provided for the incoming AC/DC power supplies and bus wires shall be run for power distribution to different panels. D.C. supply isolating switches shall be double pole, double throw with off and A.C. supply isolating switches shall be 4-pole, double throw type.
- 4.06.03 Fuse and link shall be provided for individual circuits for protection and also for isolation from bus wire without disturbing other circuits.
- 4.06.04 The fuse requirements in each panel shall be grouped in easily accessible fuse blocks or distribution panel. The grouping shall be done in a neat and orderly fashion.
- 4.06.05 Alarm relays with reverse flag shall be provided to annunciate failure of main incoming A.C. and D.C. power supplies and annunciation D.C. supply in each panel. Lamp indications shall be provided individually for main D.C. supply-1 fail, main D.C. supply-2 fail, and panel annunciation D.C. supply fail. A common A.C. electric bell shall be provided to give an audible alarm in case of failure of D.C. supply-1/D.C. supply-2/annunciation D.C. supply in any panel. A common push-button shall also be provided for cancellation of lamp indications and audible alarm.
- 4.06.06 Separate circuits shall be provided for (a) indication and alarm (b) tripping, and (c) control.
- 4.06.07 For lighting, auxiliary supply and space heating A.C. supply shall be used. D.C. supply shall be used for providing control supply to annunciator.
- 4.06.08 Bus wires of adequate capacity shall be provided to distribute the incoming supplies to different cubicles of a VDB. Isolating switch fuse units shall be provided at each cubicle for A.C/D.C supplies.
- 4.07.00 **Wiring**

- 4.07.01 The panels shall be fully wired up at the factory to ensure proper functioning of control, protection and metering schemes.
- 4.07.02 All spare contacts of relays and switches shall be wired up to terminal blocks.
- 4.07.03 Wiring shall be done with 1100V grade fire resistance PVC insulated stranded copper conductor of not less than 2.5 Sq.mm cross section for current control circuits and voltage circuits.
- 4.07.04 Each wire shall be ferruled by plastic tube with indelible ink print at both end having terminal Block No., terminal numbers, destination number as per approved wiring drawing.
- 4.07.05 All wire termination shall be made with insulated sleeve solderless crimping type tinned copper lugs. Wires shall not be tapped or spliced between terminals.
- 4.07.06 Wiring shall be neatly bunched in groups by non-metallic cleats or bands. Each group shall be adequately supported along its run to prevent sagging or strain on the termination.
- 4.07.07 Colour codes shall be used for wiring as per latest revision of IS: 375.
- 4.08.00 **Terminal Block**
- 4.08.01 Multi-way terminal blocks complete with necessary binding screws and washers for wire connections and marking strip for circuit identification shall be furnished for terminating the panel wiring and outgoing cables. Terminals shall be box-clamp type, 10 sq.mm. minimum. Terminals for C.T. secondary leads shall have provision of shorting and grounding.
- 4.08.02 Not more than two wires shall be connected to one terminal. If necessary, a number of terminals shall be jumpered together to provide wiring points.
- 4.08.03 Each terminal shall be identified with designation as per approved schematic. At least 20% of the total number of active terminals shall be furnished as spare in each panel.
- 4.08.04 The wiring and terminals shall be so arranged that individual wires of an external cable can be connected to consecutive terminals.
- 4.08.05 The terminal blocks shall be located to allow easy access and also to suit floor openings for cable entry.
- 4.08.06 The terminal blocks within the panels shall be mounted on vertical support brackets. The support brackets shall be tack welded to the interior sheet steel mounting plates of the cabinet. Support brackets shall not be welded directly to the walls of the enclosure. The terminal blocks shall be attached to the support brackets with round head machine screws.
- 4.08.07 Terminal blocks shall generally be mounted vertically with adequate spacing (not less than 100 mm) between adjacent rows.
- 4.08.08 The bottom of the terminal block shall be at least 200 mm above the incoming cable gland plate.

4.09.00 **Cable Entry**

4.09.01 The Control Boards/Panels shall have provisions of cable entry from the bottom. Bottom plate shall be provided to make entry dust-tight. L.P.B. stations and Local Isolating Switch Units shall have provision for cable/conduit entry from both top and bottom. Suitable cable gland-plates shall be provided.

4.10.00 **Grounding**

4.10.01 50 x 6 mm GI ground bus shall be provided in each control panel extending along the entire length of the assembly.

4.10.02 The ground bus shall have two-bolt drilling with GI bolts and nuts at each end and shall be suitable for connection to 50 x 6 mm G.S. flat.

4.10.03 The ground bus shall be bolted to the panel structures and shall effectively ground the entire assembly. The cases of meters, relays and switching devices shall be grounded through the steel structure.

4.10.04 Whenever a circuit is grounded, a single wire from the circuit shall be run independently to the ground bus and connected to it.

4.11.00 **Painting**

4.11.01 For paint shade finish, refer Section-X of Volume: II-A : Lead Specification.

4.11.02 Caution Notice plate shall be affixed at the back of each vertical panel.

4.12.00 **Switches**

4.12.01 Switches shall be dust protected, heavy duty, switchboard type, complete with escutcheon plate. Contacts shall be silver surfaced and rated minimum 10A at operating voltage.

4.12.02 415V Breaker control switches shall be 3-position (TRIP/NORMAL/-CLOSE), 120°, spring return to neutral with lost motion device, non-lockable, sequence device, pistol grip handle. RED/AMBER/GREEN (circuit breaker CLOSED/TRIPPED-OR-TRIP CIRCUIT UNHEALTHY/OPEN) indicating lamps shall be provided with each breaker control switch.

4.12.03 Contact details and type of handle required for other types of switches are given below :

Sl. No.	Application	Switch description
a)	Synchronizing Selector switch	180°, 4-position (INCOMER-1/BUS-SECTION / INCOMER-2/OFF), stay put type, pistol grip handle. OR

- 120°, 3-position (INCOMER/TIE/OFF) stayput type, pistol grip handle.
- b) Trip Selector Switch 120°, 3-position (INCOMER-1/BUS-SECTION OR TIE/INCOMER-2), stayput type, pistol grip handle.
- c) Meter Selector Switch 4-position (OFF/R/Y/B for ammeter selector switch and OFF/R/Y/YB/RB for voltmeter selector switch), maintained contact, stay-put type, knob handle. Ammeter selector switches shall have make-before- break contacts.
- d) Auto-Manual Selector switch 120°, 2-position (AUTO/MANUAL), stayput type, non-lockable, spade handle.
- e) On-off Switch/Local-Remote Selector Switch 90°, 2-position (ON/OFF OR LOCAL/ REMOTE), stayput type, non-lockable, spade handle
- 4.12.04 Any other type of switch, if required, shall be subjected to approval of purchaser.
- 4.12.05 Tenderer shall decide the number of switch contacts taking into account the scheme requirements and spares.
- 4.13.00 **Fuses**
- 4.13.01 Fuses shall be HRC, preferably link type, with a minimum interrupting capacity equal to the system short circuit current.
- 4.13.02 Fuses shall be furnished complete with fuse boxes and fittings of such design as to permit easy and safe replacement of fuse element. Visible indication shall be provided on blowing of the fuse.
- 4.13.03 Motor fuse characteristics and ratings shall be chosen to ride over motor starting period without blowing. The fuse on incoming feeder, wherever provided, shall be chosen to provide discrimination with motor/feeder fuses.
- 4.14.00 **Contactors**
- 4.14.01 Contactors shall be three pole, air break type, with non-bouncing silver/silver alloy contacts. Contactor duty shall be class III - category AC3 for unidirectional drives and AC4 for bi-directional and inching drives/class I - category DC2.
- 4.14.02 Each contactor shall be provided with minimum two (2) N/O and two (2) N/C auxiliary contacts rated 10 A at operating voltage. The exact requirement of

contacts shall be decided by the Tenderers taking into account the scheme requirements and spares.

4.14.03 Contactor starters shall comply with the requirements of IS-8544 (Part - 1) in respect of co-ordination of the characteristics of contactor, overload relay, and fuse. The type of co-ordination shall be Type-C as per IS-8544.

4.15.00 **Thermal Overload**

4.15.01 Thermal overload relays shall be three elements, positive acting, ambient temperature compensated with adjustable settings.

4.15.02 Single phasing preventor shall be provided as an inbuilt feature of the thermal overload relay.

4.15.03 Overload relays shall be manual reset type with change over contacts. Resetting of relays shall be possible with compartment door closed. Colour of resetting button shall be BLACK.

4.15.04 Relays for fan motors having long starting time shall be saturable core C.T. operated.

4.16.00 **Current Transformers**

4.16.01 Current transformers shall be cast-resin type. All secondary connections shall be bought out to terminal blocks where wye or delta connection will be made.

4.16.02 Accuracy class of the current transformers shall be:

- a) Class PS for differential.
- b) Class 5P20 for other relaying.
- c) Class 1.0 ISF < 5 for metering.

Other CT particulars like ratio, burden, knee point, excitation current & secondary resistance shall be decided by the tenderers.

4.16.03 Drives requiring current monitoring shall be provided with current transducers with calibration for full-scale reading. The output shall be 4-20 mA D.C; 4-18mA of which shall correspond to the normal range and 18-20 mA shall correspond to the suppressed range.

4.17.00 **Voltage Transformers**

4.17.01 Voltage transformers shall be cast-resin, drawout type and shall have an accuracy class of 1.0.

4.17.02 High voltage windings of voltage transformer shall be protected by current limiting fuses. The voltage transformer and fuses shall be completely disconnected and visibly grounded in fully draw out position.

- 4.17.03 Secondary winding MCBs, sized to prevent overload shall be installed in all ungrounded secondary leads. MCBs shall be suitably located to permit easy replacement while the switchgear/PMCC is energized.
- 4.17.04 Both primary side & secondary side fuse failure / voltage loss monitoring system of VT shall be provided.
- 4.18.00 **Push Button**
- 4.18.01 All push buttons shall be oil tight, heavy duty, push to actuate type, with coloured button and inscription plate marked with its function. The colour of "ON" and "OFF" push buttons shall be RED and GREEN respectively. RESET push buttons shall be coloured black.
- 4.18.02 Each push button shall have minimum 2 NO. + 2 NO. contacts, rated 10A at 240V AC and 2A at 220V DC.
- 4.18.03 Push buttons shall be shrouded type except for emergency trip button, which shall be mushroom type for easy identification.
- 4.19.00 **Lamps**
- 4.19.01 Lamps shall be LED type.
- 4.19.02 LED lamp shall be made in accordance with InP Technology (Aluminium Indium Gallium Phosphide Technology). The body shall be made of Poly Carbonate Unbreakable Lens. LED shall be protected by inbuilt fuse with surge suppressor or leakage voltage glow protection. LED circuit shall be PCB mounted. Intensity shall be greater than 200 mcd. All Push Button lamp shall be as per LED indicating lamp.
- 4.20.00 **Operating Range**
- All instruments shall be generally suitable for operation on 1A or 5A C.T. secondary circuit and/or 110V V.T. secondary circuit.
- 4.21.00 **Meters**
- 4.21.01 All indicating instruments shall be switchboard type, back connected, suitable for flush mounting, 96 x 96 mm with 240 Deg. scale, antiglare glass and accuracy class of 0.5. The dials shall be made of such material as to ensure freedom from warping, fading, and discolouring during the lifetime of the instruments.
- 4.21.02 All indicating instruments shall be enclosed in dust-tight cases suitable for tropical use.
- 4.21.03 Meters shall have provision for zero-adjustment from front of the panel.
- 4.21.04 Meters shall be compensated for temperature errors and factory calibrated to read the primary quantities directly without using a multiplying factor.
- 4.21.05 D.C. ammeters, wherever required, shall be provided with external shunt if the current exceeds 5A. The rated voltage drop for the shunts shall be 75mV.

- 4.22.00 **Annunciator System**
- 4.22.01 Each control panel shall be provided with an annunciator window board. The annunciator boards shall be back-connected and suitable for semi-flush mounting.
- 4.22.02 The annunciator system shall be solid state type with optical isolation for input signals. The functional requirements shall be as per Annexure-C.
- 4.22.03 Each annunciator group shall be independent, complete with its own power supply, acknowledge-reset-test buttons and other necessary accessories. Hooter for audible alarm shall be common for each control panel assembly.
- 4.22.04 Each annunciator group shall be provided with a common alarm relay for group alarm annunciation in remote control room. The common alarm relay will operate on actuation of any alarm point of the group.
- 4.22.05 The annunciator shall be non-integral type with hardware box mounted separately for easy access and maintenance.
- 4.22.06 Audible alarms with different tones shall be used for trip, non-trip and ring back functions.
- 4.22.07 The window size shall be such as to accommodate minimum three (3) lines of twelve (12) characters each. Each character shall be minimum 4.75 mm high.
- 4.22.08 The annunciator system shall be suitable for operation from both NO and NC type initiating contacts.
- 4.22.09 At least 10% spare channels and window facia shall be provided in each annunciator group.
- 4.23.00 **Relays**
- 4.23.01 Auxiliary relays shall be furnished in fixed, dust-tight, casings and mounted inside the panel.
- 4.23.02 The relays shall have adequate numbers of contacts to suit scheme requirements. Besides, each relay shall have spare contacts for future use.
- 4.23.03 Contacts shall be silver-surfaced, bounce-free, and capable of repeated operation without deterioration.
- 4.24.00 **Auxiliary Devices**
- 4.24.01 The Contractor shall furnish, install, and wire-up all auxiliary devices such as timing / switching / lockout / auxiliary relays/auxiliary contactors, etc. as required for the proper functioning of the approved schemes.
- 4.24.02 The Contractor shall number the various types of relays and contactors as per the numbers appearing in the approved Schematic/Wiring appearing in the approved Schematic/Wiring diagrams.
- 5.00.00 **TESTS**

- 5.01.00 All Control Boards/Panels, L.I.S. Units and L.P.B. Stations shall be completely assembled, wired, adjusted and tested at the factory prior to shipment to ensure accuracy of wiring, correctness of control scheme and proper functioning of all components.
- 5.02.00 **Routine Tests**
- 5.02.01 The tests shall include wiring continuity tests, high voltage tests, interlock & sequential operation test, insulation measurement test both before and after high voltage test, and functional tests to ensure accuracy of wiring operation of the control/ protection/metering schemes and individual equipment. Detailed test report including procedure and drawing shall be furnished.
- 5.02.02 All switches, meters, relays and other devices shall be tested and calibrated in accordance with relevant IS standards.
- 5.03.00 Type test certificate on any equipment, if so desired shall be furnished. Otherwise the equipment shall have to be type tested, free of charge, to prove the design.
- 6.00.00 **DRAWINGS, DATA & MANUALS**
- 6.01.00 Drawings, Data & Manuals shall be submitted in triplicate with the bid and in quantities and procedures as specified in General Conditions of Contract and/or elsewhere in the specification for approval and subsequent distribution after the issue of 'Letter of Intent'.
- 6.02.00 **To be submitted with the Bid**
- 6.02.01 General Arrangement drawings and cross-section of each equipment showing constructional features, cable entry points etc.
- 6.02.02 Typical foundation plan.
- 6.02.03 Bill of Materials.
- 6.02.04 Technical leaflet and Catalogues of:
- a) Local Control Boards and Local Starter-cum-Control panels
 - b) Local Isolating switch units
 - c) Local Push Button Stations
 - d) Switches and Lamps
 - e) Meters, relays, push buttons
 - f) Switch fuse units
 - g) Annunciator System
 - h) Auxiliary Devices

- i) Terminal Blocks/glands.
- j) Temperature Scanner

6.02.00 To be submitted for Owner / Purchaser's Approval and Distribution

All relevant drawings and data pertaining to the equipment like GTP, GA drawing, foundation plan, BOM, control & schematics, QAP, etc. shall be submitted by the Bidder for approval of Owner/Owner's consultant. Also refer clause no. 1.19.02(u) of Section-I of Volume – V-A: Technical Specifications for Electrical Equipment & Accessories.

ANNEXURE-A

RATINGS & REQUIREMENTS

1.0	Local Control Board		
1.1	General		
	Type	:	Fixed type
	Service	:	Indoor
	Enclosure	:	IP-54
1.2	System		
	Voltage	:	415 Volt \pm 10%
	Phase	:	3
	Frequency	:	50 Hz +3% to -5%
	System	:	Solidly grounded
1.3	Rated Current at 50°C		
	Bus bar	:	To be decided by the Tenderers
	Switches	:	To be decided by the Tenderers
1.4	Short Circuit Rating		
	Interrupting	:	50 kA
	Short time for 1 Second	:	50 kA
1.5	Insulation Level	:	2.5 kV for 1 min.

ANNEXURE-B

A.C./D.C. POWER SUPPLY

1.0 **System Voltages**

All systems shall be designed for satisfactory operation from the following power supply :-

A.C. Supply : 240 Volt, 1 Phase, 50 Hz, 2 wire, effectively grounded system.

Fault level 50 kA rms Symmetrical.

D.C. Supply : 220V, 2 Wire, ungrounded.

Fault level 25* kA

* Indicative only actual value will be decided by the Bidder, after substantiating the same by calculation.

2.0 **Permissible Variation**

Equipment and accessories shall be suitable for operation over the entire range of voltage/frequency variation as listed below :

A.C. Supply:

Voltage : $\pm 10\%$

Frequency : +3% to -5%

Combined Volt & Freq. : 10% (absolute sum)

D.C. Supply:

Voltage : 187 to 242

Service Voltage for Control Panels/
Distribution Boards : 240V $\pm 10\%$, 1ph, 50Hz +3% to -5%

ANNEXURE-C

FUNCTIONAL REQUIREMENTS OF ANNUNCIATOR

TYPE

The annunciation system shall be manually reset type with ring back facility, suitable for operation from 220V DC ungrounded supply.

FUNCTION

The sequence of operation shall be similar to ISA-2A with fast/slow blinking as detailed below:

Field Condition	Visual Display	Audible Alarm	Ringback Alarm
Normal	Off	Silent	Silent
Abnormal	Fast blinking	On	Silent
Acknowledge	Steady On	Silent	Silent
Return to normal	Slow blinking	Silent	On
Reset	Off	Silent	Silent
Normal Before Acknowledge	Slow blinking	On	On
Acknowledge	Steady On	Silent	On
Reset	Off	Silent	Silent
Test	Fast blinking	On	On

ANNEXURE-D

AREA WISE INDICATIVE LIST OF LOCAL CONTROL BOARDS

Sl. No.	Description
1.	C.W. System Electrical Control Board
2.	Electrical Control Board for MCC/PMCC located in Ash-Slurry and Ash-Water Building.
3.	Electrical Control Boards for ESP PCC/PMCC
4.	Electrical Control Board for Fuel Oil Pressurizing system
5.	Electrical Control Board for Fuel Oil Unloading and Forwarding MCC
6.	Electrical Control Boards for Raw water MCC
7.	Electrical Control Boards for Hydrogen generation plant

Note: The above list is indicative only. The above boards shall be hooked-up to respective system PLCs. In addition to the above Electrical Control Boards, necessary local panels/remote panel shall be provided for respective system/equipment/drive, e.g., BFP, Hydrogen-seal Oil system for Generator, ESP, etc. as described in respective sections of mechanical specification.

ANNEXURE-E

**LOCAL CONTROL PANEL / LOCAL STARTER PANEL
FOR COAL HANDLING PLANT**

1.00.00 **DESIGN CRITERIA**

1.01.00 **Stacker/Reclaimer MCC & Control Desk**

The power supply from 3.3 kV CHP switchgear shall be achieved through one (1) number land mounted load break isolator, one (1) number fuse cum junction box located near centre or travel, one (1) number machine mounted load break isolator, line P.T with voltmeter on 3.3 kV side, L.T Air Circuit Breaker, Ammeter with selector switch, Voltmeter with selector switch etc.

Power CRD shall be connected to isolator panel mounted on the machine. H.T. fuses for the primary side of the transformer shall be housed inside the isolator panel on machine. Fuses shall be provided with the striker pin mechanism. Specification of Load break isolator is governed by HT Switchgear Specification

- 1.01.01
- a) One number Stacker-Reclaimer MCC shall be provided on the mobile Stacker-Reclaimer. This MCC shall receive power at 433V, 50 Hz, from the output of a 3.3 kV/433V, dry type cast resin power transformer located on the mobile machine, through suitable cables.
 - b) Power shall be received at the panel by means of ACB unit. The ACB shall be series trip type with short circuit and ground fault releases having adjustable settings. Necessary CT ammeter, ammeter selector switch; voltmeter; voltmeter selector switch; R/Y/B indication lamps shall be available on the MCC. Power supply for indication of breaker including load break isolator shall be derived from the UPS of PLC. The specification requirement of MCC is guided by respective 415V PMCC/MCC specification.
 - c) Stacker/Reclaimer is PLC controlled. Under manual local operation it shall only be possible to run individual equipment by passing all process interlock. Under manual remote operation it shall be possible to run the entire system through PLC with process and safety interlock in place. The selector switch, remote/local shall be housed in control desk.
 - d) Specification requirement of PLC has been detailed under main PLC specification with the exception of 100% hot standby mode and redundancy.
 - e) Control desk shall accommodate annunciation windows, selector switches, ammeter, voltmeter and indicating lamps for incomer, ammeter for outgoing motor feeder rated 30 kW and above.
 - f) Panel door shall be interlocked with the incoming switch such that the panel door can not be opened when the switch is 'ON'. However, necessary door interlock defeat feature shall also be provided for

testing purpose. Rating of components shall conform to the rating indicated in the enclosed component selection chart.

- g) Audio visual annunciation system shall have at least but not limited to the following annunciation points complete with Accept/Test Preset P.B.:
- i) Transformer winding temperature high.
 - ii) 415 V Incomer breaker tripped
 - iii) Boom Conveyor zero speed switch operated
 - iv) Boom Conveyor belt sway operated
 - v) Boom Conveyor pull cord switch operated
 - vi) Boom Conveyor brake not released.
 - vii) Boom Conveyor Motor overload/SPPR fault
 - viii) Back up limit switch operated.
 - ix) Wind velocity high.
 - x) Wind velocity very high.
 - xi) Slew limit switch operated.
 - xii) Slew drive fault.
 - xiii) Slew motor overload.
 - xiv) Slew drive lubrication system fault.
 - xv) Hydraulic oil temperature high.
 - xvi) Oil level low in hydraulic tank.
 - xvii) Hydraulic system filter clogged.
 - xviii) Bucket wheel brake not released.
 - xix) Bucket wheel zero speed switch fault.
 - xx) Bucket wheel motor overload/SPPR fault.
 - xxi) Power CRD motor overload.
 - xxii) Power CRD over tension switch operated.
 - xxiii) Control CRD motor overload.
 - xxiv) Control CRD over tension switch operated.
 - xxv) Travel drive brake not released.
 - xxvi) Travel drive motor overload/SPPR fault.
 - xxvii) Travel limit switch operated.
 - xxviii) Rail clamp not released.
 - xxix) DS motor overload/SPPR fault (to be provided for each motor).
 - xxx) HT load brake switch operated.

Annunciation system shall be similar to that of main Control Panel with 20% spare windows.

- h) Separate cable reeling drum shall be provided for power & control cable. Combined trailing cable shall have 24C X 2.5 mm² (cu) control cable and 8 pair 1.5 mm² (cu) screened cable for signal and communication.

1.02.00 ON/OFF operation of Wagon tippers shall be achieved from the respective Wagon tippler Control desk through PLC based logic. Control desk shall be provided in each Wagon tippler Control room for Control, Operation, Indication & Annunciation of Wagon Tippler equipment. Control desk shall interface with PLC for the entire operation and shall accommodate annunciation windows, ammeter, voltmeter, selector switches and indicating lamps for incomer, ammeter for outgoing motor feeder rated 30 kW and above. Other features as described above for the control desk of Stacker Reclaimer shall also be considered for Wagon Tippler.

1.03.00 MCC/DB/Local Starter Panel for Dust Suppression, Dust Extraction, Sump Pump, Coal Sampler, Bunker Level and other Panels

1.03.01 The Local Starter Panel shall be fixed type with compartmentalized execution. One (1) number 415 V \pm 10% 3 phase 4 wire 50 Hz +3% to -5% power supply feeder shall be provided for each panel. Power shall be received through an incoming SFU having R/Y/B indication lamps, voltmeter with selector switch, ammeter with selector switch. Individual motor feeder shall have their switch fuse, power contactor, overload relay-cum-single phasing preventor (hand reset type), stop/ start push button, auto/manual selector switch, Red/Green/Trip indication lamp, auxiliary relays, timers, etc. The stop push button shall be lockable type. Necessary interlock, annunciation, 415/240 V Transformers for control supply, space heating as applicable to meet system requirement shall also be provided and in no case derive any power supply from its main feeder. Separate feeders shall also be provided for brakes and rail clamp as applicable. Facility shall be provided for resetting the motor overload relay from outside without opening the panel door. Panel door shall be interlocked with the incoming Switch such that the door can not be opened when Switch is ON.

Specification requirement of the above including module selection chart will be governed by 415 V MCC/PMCC Specification.

1.03.02 Interlock, control, indication, annunciation etc. shall be achieved by relay logic

1.03.03 Isolation of individual circuit in the MCC/DB/Local Starter Panel shall be provided through individual Fuse.

1.03.04 Control features as described under relevant mechanical section shall be considered for interlocking and preparation of control schematic.

1.03.05 Thermostatically control space heater shall be provided.

1.03.06 Necessary door interlock defeat feature shall also be provided for testing purpose. Wherever necessary, the panels shall be designed for outdoor and of weather proof/rain protection type. Ratings of components shall be as per module selection chart indicated under 415 V PCC/PMCC/MCC Specification.

1.03.07 **Travelling Tripper DB cum Control Panel**

In addition to indication to be provided for drives, following indications shall also be provided in local panel:

- i) Brakes applied
- ii) Rail clamps applied
- iii) Flap Gate position
- iv) Travel driver over speed
- v) Travelling tripper – Forward/Reverse
- vi) Cable Reeling Drum on

Travelling tripper position on bunker shall be provided in the PLC.

Control features as described under relevant mechanical portion shall be considered for interlocking and preparation of control schematic.

Cable reeling drum shall be provided for power & control cable. Apart from meeting the requirements in respect of control, indication & annunciation and telecommunication following spare cores shall be provided:

- i) 4 pair core (Shielded) for communication.
- ii) 4 Core for control.

1.03.08 **Sump Pump Control Panel**

Sump Pump Control Panel shall be provided with level controller, necessary contacts to start pumps in auto mode when level reaches high. Further, very high level shall cause hooter to blare and the same shall stop after sometime delay. In manual mode it shall be possible to start individual pump. However, in manual mode and auto mode of operation, pump shall be tripped when level in the sump pit reaches low. Sump pumps shall be able to operate from PLC, the level switches shall be wired to PLC.

In addition to other indicating lamps level high indication lamp shall also be provided in local panel.

1.03.09 **Miscellaneous Control Panels**

Miscellaneous control panel i.e. dust suppression panel, ventilation panel, etc. shall have individual starter feeder for individual drive. Other features as specified above shall also be provided. Equipment such as Vibrating Grizzle feeders, Magnetic separators, Metal detectors, Dust suppression, Ventilation, Dust extraction, Coal Sampler, Bunker Level, Hoists etc. shall have individual starter-cum-control panels to suit individual requirements. The panels shall include all necessary feeders, start stop PB, indicating lamp, annunciation system, 415/240V control transformers for control supply and space heating as applicable to meet system requirement. For Magnetic Separators, separate panels shall be provided. One panel shall accommodate transformer & rectifier and the other panel shall accommodate incomer and other controlling items.

The requirement of 4-20 mA signals for Belt Weigher and bunker level indicator have been spell out in Mechanical Specification and accordingly the same shall be provided.

2.00.00 **SPECIFIC DESIGN REQUIREMENT**

2.01.00 **Construction**

a) **Stacker/Reclaimer/ Wagon Tippler Control Desk**

Ammeters and annunciation facia shall be mounted on the vertical portion of the panel and all push button; selector switches; indication lamps etc. shall be mounted on the desk portion. The front desk shall be with top inclined downward towards front. A removable type front door shall be provided on the desk portion along with a lockable and lift-off rear door for the panel portion of the desk-cum-panel.

Travelling Tripper/Magnetic Separator/Metal Detector/Dust Extraction/Dust Suppression/Ventilation/Coal Sampler/Bunker Level indication, Hoist/MCC/DB/Starter-Cum-Control Panel, Misc. Control Stations, Push Button Stations & Local Information Boards.

These panels/stations shall be furnished in sheet steel enclosures suitable for wall/column/floor mounting.

2.02.00 **General**

- a) Design, material selection and workmanship shall be such as to present a neat appearance outside and inside with no marks of welds, rivets, screws or bolt heads apparent from the exterior surface of the frames.
- b) Panels shall be of folded sheet steel construction, assembled on channel/angle base plates. Anti-vibration mountings shall be provided for moving equipment.
- c) All switchboard/panel frames and load bearing members shall be fabricated using suitable mild steel structural sections or pressed and shaped cold rolled sheet steel of thickness 2.0mm. Frames shall be enclosed in cold rolled sheet steel of thickness 1.6 mm. Doors and covers shall also be of cold rolled sheet steel thickness 1.6 mm. Stiffeners shall be provided wherever necessary. The gland plate thickness shall be 3.0 mm for hot/cold rolled sheet steel and 4.0 mm for non-magnetic material. The panels shall have sufficient structural reinforcement to ensure a plain surface, limit vibration and provide rigidity during despatch and installation. Vertical panels shall be freestanding type.
- d) Sufficient inter-component spacing shall be available for easy maintenance, replacement, ventilation etc. of the components. A minimum spacing of 50mm is recommended for the same.
- e) All doors, covers etc. shall be properly gasketed to make the panel effectively vermin and dust proof. Door hinges shall be concealed

type. Special dust protection measures shall be taken for panels located in dusty area.

- f) All hardware for the complete installation of the equipment including foundation and fixing bolts, nuts, washers etc. shall be supplied to suit the requirement. All bolts, nuts etc. exposed to external atmosphere shall be cadmium plated or zinc passivated.
- g) The panels shall be liberally sized so as to provide spacious layout of equipment and devices with sufficient working space in between.
- h) Shock absorbers shall be provided for panels mounted on mobile machines.
- i) Maximum and minimum height of the operating devices on all panels except Local Control Stations shall be restricted to 1800 mm and 750 mm respectively from the floor level.



**TITLE : TECHNICAL SPECIFICATION
FOR
DEBRIS FILTER (DF)**

SPEC. NO. PE-TS- 410-165-N001

VOLUME : II B

SECTION : C

REV. NO. 0

DATE : 18.06.2015

SHEET

1

of

1

**SECTION C3
DEBRIS FILTER
(C&I DETAILS)**

DEBRIS FILTER - C&I REQUIREMENTS

1.00		1 X 800 MW KOTHAGUDEM TPS, TSGENCO
2.00	SYSTEM	DEBRIS FILTER
3.00	CONTROL SYSTEM	DCS
4.00	LOCATION OF CONTROL SYSTEM	CCR
4.10	CONTROL SYSTEM SCOPE (BIDDER/ BHEL/ CUSTOMER)	BHEL
5.00	HARDWIRED INTERFACE WITH DCS (Y/N)	NA
6.00	SOFTLINK TO DCS (Y/N)	NA
7.00	PROTECTION CLASS FOR PLC / RIO PANEL	NA
8.00	CONTROL FROM PB's ON LCP/OWS ON LCP	NA
9.00	ANNUNCIATION ON LCP (Y/N) – IF Y, MIN NO. OF HARDWIRED ALARMS / INDICATIONS	NA
10.00	CONTROL FROM DCS IN CCR (Y/N)	Y
11.00	TYPE OF SOFTLINK (TP/OFC)	NA
12.00	RIO / RPU (Y/N)	NA
13.00	## NO. OF OWS / LAPTOP	NA
14.00	NO. OF PRINTER	NA
15.00	\$\$ POWER SUPPLY AVAILABLE FOR BALL MONITOR (24V DC / 110 V AC UPS / 230 V AC UPS)	NA
16.00	ACTUATOR WITH INTEGRAL STARTER (Y/N)	Y
17.00	PG/ DPG/ PS/ DPS/ PT/ DPT per Debris filter	DPT = 2 nos. DPG = 1 no.
18.00	REMARKS	
19.00	PROJECT SPECIFIC INFO	

20.00 NOTES:

1. COMPLETE CONTROL & INSTRUMENTATION FOR DEBRIS FILTER IS IN BIDDER SCOPE OF SUPPLY. ITEMS NOT SPECIFICALLY MENTIONED HOWEVER REQUIRED FOR THE COMPLETENESS OF THE SYSTEM SHALL BE SUPPLIED BY BIDDER.
2. FOR DCS CONTROLLED SYSTEMS, BIDDER TO TERMINATE ALL INSTRUMENTATION AND CONTROL ELEMENTS IN JUNCTION BOXES FOR FURTHER CABLING TO DCS BY BHEL/CUSTOMER. BIDDER TO PROVIDE INPUT/OUTPUT LIST, DRIVES LIST, JUNCTION BOX SCHEDULE AND TERMINATION DETAILS, RECOMMENDED CONTROL LOGICS / WRITE-UP ETC. DURING DETAILED ENGINEERING. COMPLETE CABLE SCHEDULE (IN BHEL EXCEL FORMAT PROVIDED IN ELECTRICAL PORTION OF THE SPECIFICATION) & CABLE INTERCONNECTION DETAILS FROM FIELD TO JB/LCP & JB/LCP TO DCS SHALL BE PROVIDED BY BIDDER.
3. ALL THE INSTRUMENTS & BIDs ALONG WITH NECESSARY FITTINGS, ACCESSORIES AND VALVE MANIFOLD ETC., INSTRUMENT RACK AND JUNCTION BOXES,ERECTION HARDWARE SHALL BE IN BIDDER'S SCOPE OF SUPPLY.
4. BIDDER TO FURNISH ELECTRICAL LOAD DATA DURING DETAILED ENGINEERING.
5. ALARM FACIA SHALL BE UNDER BIDDER'S SCOPE. NO. OF FACIA SHALL BE DECIDED DURING DETAILED ENGINEERING.
- 6.THE SCOPE OF CABLE SHALL BE REFERRED IN ELECTRICAL SCOPE SPLIT SHEET IN ELECTRICAL PORTION OF THE SPECIFICATION.
7. Two (2) sets of DF shall have one common starter Panel (Switch Gear Panel).

LEGEND:

DCS- DISTRIBUTED CONTROL SYSTEM	CCR - CENTRAL CONTROL ROOM
PLC- PROGRAMMABLE LOGIC CONTROLLER	LCP - LOCAL CONTROL PANEL (WITH PLC HARDWARE INSIDE)
RPU - REMOTE PROCESSING UNIT	RIO - REMOTE INPUT/OUTPUT PANEL

STANDARD BLOCK DIAGRAM FOR DF PACKAGE WITH DCS

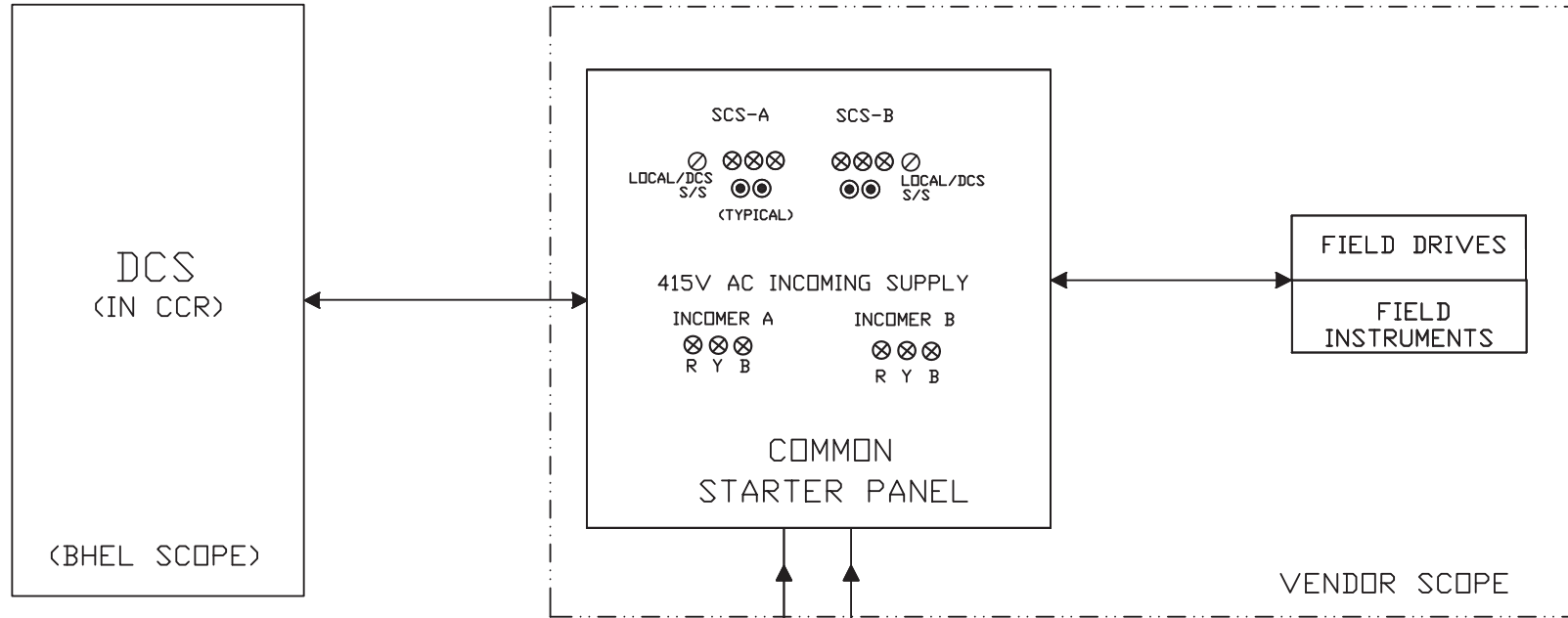

415V AC, 3P, 3WIRE
REDUNDANT FEEDER
(BY CUSTOMER/BHEL)

NOTE:-

1. COMMON LCP FOR L & R STREAM HOUSING PB , LAMPS ETC.
2. SIGNALS FOR FIELD INSTR. & FOR 'BID' DRIVES WITH INTEGRAL STARTER SHALL BE ROUTED TO DCS THROUGH STARTER PANEL.



Technical specification for
CONTROL & INSTRUMENTATION

1X800 MW KOTHAGUDEM

SPEC NO.: **PE-TS-410-145-I**

VOLUME

SECTION

REV. NO. 00

DATE : 27.05.2015

SHEET OF

ACTUATOR SPECIFICATION

VOLUME: V-A

SECTION-III

**TECHNICAL SPECIFICATION
FOR
ELECTRIC MOTOR ACTUATORS**

1.00.00 SCOPE

1.01.00 This Section covers the general requirements of Electric Motor Actuators for valves/dampers.

1.02.00 All electric motor actuators shall be furnished in accordance with this general specification and the accompanying driven equipment specification. All the electrical actuators shall be INTEGRAL type only.

2.00.00 STANDARDS

2.01.00 All electrical equipment shall conform to the latest applicable IS, ANSI and NEMA Standards, except when stated otherwise herein or in driven equipment specification.

2.02.00 Major standards, which shall be followed, are listed below. Other applicable Indian Standards for any component part even if not covered in the listed standards shall also be followed

i) IS -9334

ii) IS-325

3.00.00 SERVICE CONDITIONS

3.01.00 The actuator shall be suitable for operation in hot, humid and tropical atmosphere, highly polluted at places with coal dust and/or fly ash.

3.02.00 Unless otherwise noted, electrical equipment/system design shall be based on the service conditions and auxiliary power supply given in the general specification.

3.03.00 For actuator motor installed outdoor and exposed to direct sun rays, the effect of solar heat shall be considered in the determination of the design ambient temperature.

4.00.00 RATING

4.01.00 For isolating service, the actuator shall be rated for three successive open-close operation of the valve/damper or 15 minutes, whichever is longer.

4.02.00 For regulating service, the actuator shall be suitably time-rated for the duty cycle involved with necessary number of starts per hour, but in no case less than 150 starts per hour.

5.00.00 **PERFORMANCE**

The actuator shall meet the following performance requirements:

- 5.01.00 Open and close the valve completely and make leak-tight valve closure without jamming.
- 5.02.00 Attain full speed operation before valve load is encountered and imparts an unseating blow to start the valve in motion (hammer blow effect).
- 5.03.00 Operate the valve stem at standard stem speed and shall function against design differential pressure across the valve seat.
- 5.04.00 The motor reduction gearing shall be sufficient to lock the shaft when the motor is de-energised and prevent drift from torque switch spring pressure.
- 5.05.00 The entire mechanism shall withstand shock resulting from closing with improper setting of limit switches or from lodging of foreign matter under the valve seat.

6.00.00 **SPECIFIC REQUIREMENT**

6.01.00 **Construction**

- 6.01.01 The actuator shall essentially comprise the drive motor, torque/ limit switches, gear train, clutch, hand wheel, position indicator/ transmitter, in-built thermostat for over load protection, space heater and internal wiring.
- 6.01.02 The actuator enclosure shall be totally enclosed, dust tight, weather-proof suitable for outdoor use without necessity of any canopy. Degree of protection of enclosure for motor actuator shall be IP-65.
- 6.01.03 All electrical equipment, accessories and wiring shall be provided with tropical finish to prevent fungus growth.
- 6.01.04 The actuator shall be designed for mounting in any position without any lubricant leakage or operating difficulty.

6.02.00 **Motor**

- 6.02.01 The drive motor shall be three phase, squirrel cage, induction machine with minimum class B insulation and IPW-55 enclosure, designed for high torque and reversing service. Canopy shall be provided for outdoor service.
- 6.02.02 The motor shall be designed for full voltage direct on-line start, with starting current limited to 6 times full-load current.
- 6.02.03 The motor shall be capable of starting at 85 percent of rated voltage and running at 80 percent of rated voltage at rated torque and 85 percent rated voltage at 33 percent excess rated torque for a period of 5 minutes each.
- 6.02.04 Motor leads shall be terminated in the limit switch compartment.
- 6.02.05 Motor actuators for valves/dampers shall be with integral starter with 3phase/3wire, 415V AC and operable from remote.

- 6.02.06 Earthing terminals shall be provided on either side of the motor.
- 6.03.00 **Limit Switches**
- Each actuator shall be provided with following limit switches: -
- 6.03.01 2 torque limit switches, one for each direction of travel, self-locking, adjustable torque type.
- 6.03.02 4 end-of-travel limit switches, two for each direction of travel.
- 6.03.03 2 position limit switches, one for each direction of travel, each adjustable at any position from fully open to fully closed positions of the valve/damper.
- 6.03.04 Each limit switch shall have 2 NO + 2 NC potential free contacts. Contact rating shall be 5A at 240V A.C. or 0.5A at 220V D.C.
- 6.04.00 **Hand Wheel**
- Each actuator shall be provided with a hand wheel for emergency manual operation. The hand wheel shall de-energize automatically when the motor is energized.
- 6.05.00 **Position Indicator/Transmitter**
- The actuator shall have:
- 6.05.01 One (1) built-in local position indicator for 0-100% travel.
- 6.05.02 One (1) position transmitter, 4-20 mA current signal as position feedback, for remote indicator.
- 6.06.00 **Space Heater**
- A space heater shall be included in the limit switch compartment suitable for 240V, 1 phase, 50 Hz supply.
- 6.07.00 **Wiring**
- All electrical devices shall be wired up to and terminated in a terminal box. All wiring shall be done with 1100 V grade fire resistance PVC insulated stranded copper conductor of not less than 2.5 Sq.mm cross section. All wiring shall be identified at both ends with ferrules. All the electrical actuators shall have uniform wiring.
- 6.08.00 **Terminal Box**
- The terminal box shall be weather proof, with removable front cover and cable glands for cable connection. The terminal shall be suitable for connection of 2.5 Sq.mm copper conductor.
- 7.00.00 **ACCESSORIES**

As required for the driven equipment, the actuator shall be furnished with starting equipment mounted on the actuator. This shall include:

- 7.01.00 One (1) triple pole MCCB
- 7.02.00 One (1) reversing starter with mechanically interlocked contactors, 3 thermal overload relays, 2 NO + 2 NC auxiliary contacts for each contactor.
- 7.03.00 One (1) remote-local selector switch.
- 7.04.00 CLOSE-STOP-OPEN oil tight push buttons with indication lights.
- 7.05.00 415/240 V control transformer with primary & secondary fuses.

8.00.00 **TEST**

The actuator and all components thereof shall be subject to tests as per relevant Standards. In addition, if any special test is called for in equipment specification, the same shall be performed.

9.00.00 **DRAWINGS, DATA & MANUALS**

- 9.01.00 Drawings, Data & Manuals shall be submitted in triplicate with the bid and in quantities and procedures as specified in General Conditions of Contract and/or elsewhere in the specification for approval and subsequent distribution after the issue of 'Letter of Intent'.

9.02.00 **To be submitted with Bid**

Data sheet for each type of actuator shall be furnished along with internal wiring diagram, suggested control schematic and torque limit switch contact development and manufacturer's catalogues. Drawings, Data & Manuals shall be submitted in triplicate with the bid and in quantities and procedures as specified in General Conditions of Contract and/or elsewhere in the specification for approval and subsequent distribution after the issue of 'Letter of Intent'.

9.03.00 **To be submitted for Owner / Purchaser's Approval and Distribution**

All relevant drawings and data pertaining to the equipment like GTP, GA drawing, foundation plan, BOM, control & schematics, QAP, etc. shall be submitted by the Bidder for approval of Owner/Owner's consultant. Also refer clause no. 1.19.02(u) of Section-I of Volume – V-A : Technical Specifications for Electrical Equipment & Accessories.

ANNEXURE-A

DESIGN DATA

1.0 AUXILIARY POWER SUPPLY

S	Supply	Description	Consumer
	L.V. Supply	(i) 415V, 3Ø, 3W, 50 Hz Effectively earthed Fault level 50 kA symm. for 1 sec.	u Motors above 0.2kW pto less than 175kW.
		(ii) 240V AC/415V AC 240V, 1Ø, 2W, 50 Hz effectively earthed	o Motors upto 0.2kW. Lighting, Space heating, A.C supply for Control & protective devices.
	D.C. Supply	220V, 2W, unearthed Fault level 25* kA. for 1 sec.	& D.C. alarm, control protective devices

* Indicative only, the actual value will be decided by the Bidder, after substantiating the same by calculation.

2.0 RANGE OF VARIATION

A.C. Supply :

V	voltage	:	± 10%
	Frequency	:	+3% to -5%.
	Combined Volt + frequency	:	10% (absolute sum)

During starting of large motor, the voltage may drop to 80% of the rated voltage for a period of 60 seconds. All electrical equipment while running shall successfully ride over such period without affecting system performance.

D.C. Supply :

Voltage	:	187 to 242
---------	---	------------



Technical specification for
CONTROL & INSTRUMENTATION

1X800 MW KOTHAGUDEM

SPEC NO.: **PE-TS-410-145-I**

VOLUME

SECTION

REV. NO. 00

DATE : 27.05.2015

SHEET OF

Actuator Data Sheet

	SPECIFICATION FOR MOTORISED VALVE ACTUATOR		SPECIFICATION NO.:			
			VOLUME			
			SECTION			
			REV. NO.	00	DATE:	06.01.2015
			SHEET	1	OF	3
Data Sheet A & B						
DATA SHEET-A (TO BE FILLED BY PURCHASER)			DATA SHEET-B (TO BE FILLED-UP BY BIDDER)			
GENERAL*	* PROJECT	1 X 800 MW KOTHAGUDAM TPS				
	OFFER REFERENCE					
	* TAG NO. SERVICE					
	* DUTY	<input type="checkbox"/> ON / OFF	<input type="checkbox"/> INCHING			
	* LINE SIZE (inlet/outlet): MATERIAL					
	* VALVE TYPE	<input type="checkbox"/> GLOBE <input type="checkbox"/> GATE <input type="checkbox"/> REG. GLOBE <input type="checkbox"/> BUTTERFLY				
	* OPENING / CLOSING TIME					
	* WORKING PRESSURE					
	AMBIENT CONDITION	SHALL BE SUITABLE FOR CONTINUOUS OPERATION UNDER AN AMBIENT TEMP. OF 0-55 DEG C AND RELATIVE HUMIDITY OF 0-95%				
	VALVE SEAT TEST PRESS	BIDDER TO SPECIFY				
	REQUIRED VALVE TORQUE	BIDDER TO SPECIFY				
ACTUATOR RATED TORQUE	BIDDER TO SPECIFY					
CONSTRUCTION AND SIZING	CONSTRUCTION	TOTALLY ENCLOSED, DUST TIGHT, WEATHER PROOF, SUITABLE FOR OUTDOOR USE WITHOUT CANOPY, IP:65				
	MECHANICAL POSITION INDICATOR	TO BE PROVIDED FOR 0-100% TRAVEL				
	BEARINGS	DOUBLE SHIELDED, GREASE LUBRICATED ANTI-FRICTION.				
	GEAR TRAIN FOR LIMIT SWITCH/TORQUE SWITCH OPERATION	METAL (NOT FIBRE GEARS). SELF-LOCKING TO PREVENT DRIFT UNDER TORQUE SWITCH SPRING PRESSURE WHEN MOTOR IS DE-ENERGIZED.				
	SIZING	OPEN/CLOSE AT RATED SPEED AGAINST DESIGNED DIFFERENTIAL PRESSURE AT 90% OF RATED VOLTAGE. FOR ISOLATING SERVICE THREE SUCCESSIVE OPEN-CLOSE OPERATIONS OR 15 MINS. WHICHEVER IS HIGHER. FOR REGULATING SERVICE - 150 STARTS/HR MINIMUM				
HANDWHEEL	* REQUIRED	<input checked="" type="checkbox"/> YES	<input type="checkbox"/> NO			
	* ORIENTATION	<input type="checkbox"/> TOP MOUNTED	<input type="checkbox"/> SIDE MOUNTED			
	*TO DISENGAGE AUTOMATICALLY DURING MOTOR OPERATION.					
ELECTRIC ACTUATOR	ACTUATOR MAKE/MODEL	BIDDER TO SPECIFY				
	MOTOR MAKE / MODEL / TYPE / RATING (KW)	BIDDER TO SPECIFY				
	@ MOTOR TYPE	SQUIRREL CAGE INDUCTION MOTOR, STARTING CURRENT LIMITED TO SIX TIMES THE RATED CURRENT-INCLUSIVE OF I.S. TOLERANCE				
	ACTUATOR APPLICABLE WIRING DIAGRAM	<input checked="" type="checkbox"/> ENCLOSED <input checked="" type="checkbox"/> DRG. NO. 3-V-MISC-24227 R00 (INDICATIVE)				
	COLOUR SHADE	<input checked="" type="checkbox"/> BLUE (RAL 5012), To be decided during detail engg.				
	PAINT TYPE (## Refer Notes)	<input type="checkbox"/> ENAMEL	<input checked="" type="checkbox"/> EPOXY	<input type="checkbox"/>		
	SHAFT RPM	BIDDER TO SPECIFY				
	OLR SET VALUE	BIDDER TO SPECIFY				
	@ STARTING / FULL LOAD CURRENT	BIDDER TO SPECIFY				
	NO. OF REV FOR FULL TRAVEL	BIDDER TO SPECIFY				
	@ PWR SUPP TO MTR / STARTER	415V, 3PH, AC, 3 WIRE				
	@ CONTROL VOLTAGE REQUIREMENT	TO BE DERIVED FROM THE POWER SUPPLY TO THE STARTER <input type="checkbox"/> 230 V <input type="checkbox"/> 110 V				
	@ ENCLOSURE CLASS OF MOTOR	<input type="checkbox"/> IP 65	<input type="checkbox"/> FLAME PROOF			

	SPECIFICATION FOR MOTORISED VALVE ACTUATOR		SPECIFICATION NO.:				
			VOLUME				
			SECTION				
			REV. NO.	00	DATE:	06.01.2015	
			SHEET	2	OF	3	
Data Sheet A & B							
DATA SHEET-A (TO BE FILLED BY PURCHASER)				DATA SHEET-B (TO BE FILLED-UP BY BIDDER)			
INTEGRAL STARTER	@ INSULATION CLASS	CLASS-F TEMP. RISE LIMITED TO CLASS-B					
	@ WINDING TEMP PROTECTION	<input checked="" type="checkbox"/> THERMOSTAT (3 Nos.,1 IN EACH PHASE) <input type="checkbox"/>					
	SINGLE PHASE / WRONG PHASE SEQUENCE PROTECTION	REQUIRED					
	INTEGRAL STARTER	<input checked="" type="checkbox"/> REQUIRED <input type="checkbox"/> NOT REQUIRED					
	TYPE OF SWITCHING DEVICE	<input checked="" type="checkbox"/> CONTACTORS <input type="checkbox"/> THYRISTORS					
	TYPE	<input checked="" type="checkbox"/> CONVENTIONAL <input type="checkbox"/> SMART (NON-INTRUSIVE)					
	IF SMART	NOT APPLICABLE					
	a) SERIAL LINK INTERFACE	<input type="checkbox"/> INTEGRAL <input type="checkbox"/> FIELD MOUNTED					
	b) SERIAL LINK PROTOCOL	<input type="checkbox"/> FOUNDATION FIELD-BUS <input type="checkbox"/> PROFI-BUS <input type="checkbox"/> DEVICE NET <input type="checkbox"/>					
	c) SERIAL LINK MEDIA	<input type="checkbox"/> TWISTED PAIR Cu-CBL <input type="checkbox"/> CO-AXIAL Cu-CBL <input type="checkbox"/> OFC					
	d) HAND HELD PROGRAMMER	<input type="checkbox"/> REQUIRED <input type="checkbox"/> NOT REQUIRED					
	e) TYPE OF HAND HELD PROGRAMMER	<input type="checkbox"/> BLUETOOTH <input type="checkbox"/> INFRARED <input type="checkbox"/>					
	f) MASTER STATION	<input type="checkbox"/> REQUIRED <input type="checkbox"/> NOT REQUIRED					
	g) MASTER STN INTRFACE WITH DCS	<input type="checkbox"/> MODBUS <input type="checkbox"/> TCP/IP					
	h) DETAILS OF SPECIAL CABLE	<input type="checkbox"/> ENCLOSED <input type="checkbox"/> NOT REQUIRED					
	STEP DOWN CONT. TRANSFORMER	<input checked="" type="checkbox"/> REQUIRED					
	OPEN / CLOSE PB	<input checked="" type="checkbox"/> REQUIRED <input type="checkbox"/> NOT REQUIRED					
STOP PB	<input checked="" type="checkbox"/> REQUIRED <input type="checkbox"/> NOT REQUIRED						
INDICATING LAMPS	<input checked="" type="checkbox"/> REQUIRED <input type="checkbox"/> NOT REQUIRED						
LOCAL REMOTE S/S	<input checked="" type="checkbox"/> REQUIRED <input type="checkbox"/> NOT REQUIRED						
STATUS CONTACTS FOR MONITORING	<input checked="" type="checkbox"/> REQUIRED <input type="checkbox"/> NOT REQUIRED						
INTEGRAL STARTER DISTURBED SIGNAL	REQUIRED (O/L RELAY OPERATED, CONT. /POWER SUPPLY FAILED, S/S IN LOCAL, TORQUE SWITCH OPTD. MID WAY)						
INTERPOSING RELAY/OPTO COUPLER (Applicable for integral Starter)	TYPE OF ISOLATING DEVICE	<input checked="" type="checkbox"/> INTERPOSING RELAY <input type="checkbox"/> OPTO COUPLER <input type="checkbox"/> EITHER					
	QUANTITY	<input type="checkbox"/> 2 NOs. <input checked="" type="checkbox"/> 3 NOs.					
	DRIVING VOLTAGE	<input checked="" type="checkbox"/> 20.5 – 24V DC <input type="checkbox"/> _____ V DC					
	DRIVING CURRENT	<input checked="" type="checkbox"/> 125mA MAX <input type="checkbox"/> _____ mA MAX					
	LOAD RESISTANCE	<input checked="" type="checkbox"/> > 192 ohms - <25 k ohms <input type="checkbox"/> > _____ ohms - < _____ ohms					
TORQUE SWITCH (Not Applicable for Smart Actuator) (\$\$ Refer Notes)	MFR & MODEL NO.	BIDDER TO SPECIFY					
	OPEN / CLOSE	<input checked="" type="checkbox"/> 1 No. <input type="checkbox"/> 2Nos. / <input checked="" type="checkbox"/> 1 No. <input type="checkbox"/> 2Nos					
	CONTACT TYPE	2 NO + 2 NC					
	RATING	5A 240V AC AND 0.5A 220V DC					
	CALIBRATED KNOBS(OPEN&CLOSE TS)	REQUIRED FOR SETTING DESIRED TORQUE					
	ACCURACY	+3% OF SET VALUE					
LIMIT SWITCH (Not Applicable for Smart Actuator) (\$\$ Refer Notes)	MFR & MODEL NO.	BIDDER TO SPECIFY					
	OPEN : INT : CLOSE	<input type="checkbox"/> 1 No <input checked="" type="checkbox"/> 2 Nos.	2 Nos. (ADJ.)	<input type="checkbox"/> 1 No. <input checked="" type="checkbox"/> 2Nos.			
	CONTACT TYPE	2 NO + 2 NC					
	RATING (AC / DC)	5A 240V AC AND 0.5A 220V DC					

	SPECIFICATION FOR MOTORISED VALVE ACTUATOR		SPECIFICATION NO.:			
			VOLUME			
			SECTION			
			REV. NO.	00	DATE:	06.01.2015
			SHEET	3	OF	3
Data Sheet A & B						
DATA SHEET-A (TO BE FILLED BY PURCHASER)			DATA SHEET-B (TO BE FILLED-UP BY BIDDER)			
POSITION TRANSMITTER	POSITION TRANSMITTER	<input checked="" type="checkbox"/> REQUIRED <input type="checkbox"/> NOT REQUIRED				
	MFR & MODEL NO.	BIDDER TO SPECIFY				
	TYPE	<input type="checkbox"/> ELECTRONIC (2 WIRE) R/I CONVERTER <input checked="" type="checkbox"/> ELECTRONIC (2 WIRE) CONTACTLESS				
	SUPPLY	<input checked="" type="checkbox"/> 24V DC <input type="checkbox"/>				
	OUTPUT	<input checked="" type="checkbox"/> 4-20mA				
	ACCURACY	± 1% FS				
SPACE HEATER	@SPACE HEATER	REQUIRED				
	@ POWER SUPPLY (NON INTEGRAL)	240V AC, 1 PH., 50 Hz				
	@ POWER SUPPLY (INTEGRAL)	240V AC, 1 PH/415/240 V CTRL TRANSFORMER WITH PRIMARY AND SECONDARY FUSES				
	@ RATING					
TERMINAL BOX	ACTUATOR/MOTOR TERMINAL BOX	REQUIRED				
	ENCL CLASS ACTUATOR/MOTOR T.B.	@ <input type="checkbox"/> IP 68 @ <input type="checkbox"/>				
	@ EARTHING TERMINAL	REQUIRED				
	PLUG & SOCKET (9 PIN) (FOR COMM, LS/TS FEED BACK, PoT)	<input type="checkbox"/> REQUIRED <input checked="" type="checkbox"/> NOT REQUIRED <input type="checkbox"/> 2 NOS. <input type="checkbox"/>				
CABLE GLANDS	@ POWER CABLE GLAND	SIZE:-----				
	@ SPACE HEATER CABLE GLAND	SIZE:-----				
	OTHER CONTROL CABLE GLANDS-1	INSTRUMENT CABLE SIZE FOR ON/OFF DUTY VALVES SHALL BE 8PX0.5 SQMM - ONE CABLE GLAND OF OD SIZE 20 MM. INSTRUMENT CABLE SIZE FOR INCHING DUTY TYPE VALVES SHALL HAVE TWO NO. CABLES (ONE NO. 8PX0.5 SQMM AND 2ND 2PX0.5 SQMM) - TWO NO. GLANDS OF OD SIZES 20 MM & 15 MM.				
	OTHER CONTROL CABLE GLANDS-2					
WEIGHT	TOTAL WEIGHT (ACTUATOR + ACCESSORIES)	BIDDER TO SPECIFY		_____ Kg.		
	NOTES: 1. SCOPE: DESIGN, MANUFACTURE, INSPECTION, TESTING AND DELIVERY TO SITE OF ELECTRIC ACTUATOR FOR INCHING OR OPEN / CLOSE DUTY. 2. CODES & STANDARDS: DESIGN AND MATERIALS USED SHALL COMPLY WITH THE RELEVANT LATEST NATIONAL AND INTERNATIONAL STANDARD. AS A MINIMUM, THE FOLLOWING STANDARDS SHALL BE COMPLIED WITH: IS-9334, IS-2147, IS-2148, IS-325, IS-2959, IS-4691 AND IS-4722 3. TEMPERATURE RISE SHALL BE RESTRICTED TO 70 DEG. C FOR AMBIENT TEMPERATURE OF 50 DEG C. 4. CABLE GLANDS OF DOUBLE COMPRESSION TYPE, BRASS MATERIAL, WITH NICKEL COATING SHALL BE PROVIDED. 5. THE TORQUE SWITCHES SHALL BE PROVIDED WITH MECHANICAL LATCHING DEVICE TO PREVENT OPERATION WHEN UNSEATING FROM THE END POSITIONS. THE LATCHING DEVICE SHALL UNLATCH AS SOON AS THE VALVE LEAVES THE END POSITION. IF SUCH PROVISION IS NOT POSSIBLE, THE TORQUE SWITCHES SHALL BE BYPASSED BY END-POSITION LIMIT SWITCHES WHICH OPENS ON VALVE LEAVING END POSITION. THESE LIMIT SWITCHES ARE ADDITIONAL TO THE NUMBER OF LIMIT SWITCHES SPECIFIED ELSEWHERE. 6. THE MOTOR SHALL OPERATE SATISFACTORILY UNDER THE +/- 10% SUPPLY VOLTAGE VARIATION AT RATED FREQUENCY. -5% TO +3% VARIATION IN FREQUENCY AT RATED SUPPLY VOLTAGE, SIMULTANEOUS VARIATION IN VOLTAGE & FREQUENCY THE SUM OF ABSOLUTE PERCENTAGE NOT EXCEEDING 10%. 7. THE MOTOR SHALL BE SUITABLE FOR DIRECT ON LINE STARTING. \$\$ TORQUE SWITCH & LIMIT SWITCH SHALL ACT INDEPENDENT OF EACH OTHER. TANDEM OPERATION IS NOT ACCEPTABLE. ## EPOXY PAINT IS RECOMMENDED FOR COASTAL AREAS.					
			VENDOR COMPANY SEAL			
			NAME			
			SIGNATURE			
			DATE			
NOTES* = TO BE FILLED BY MPL (LEAD AGENCY). @ = TO BE FILLED BY ES						

DRAWING NO. 3-V-MISC-24227

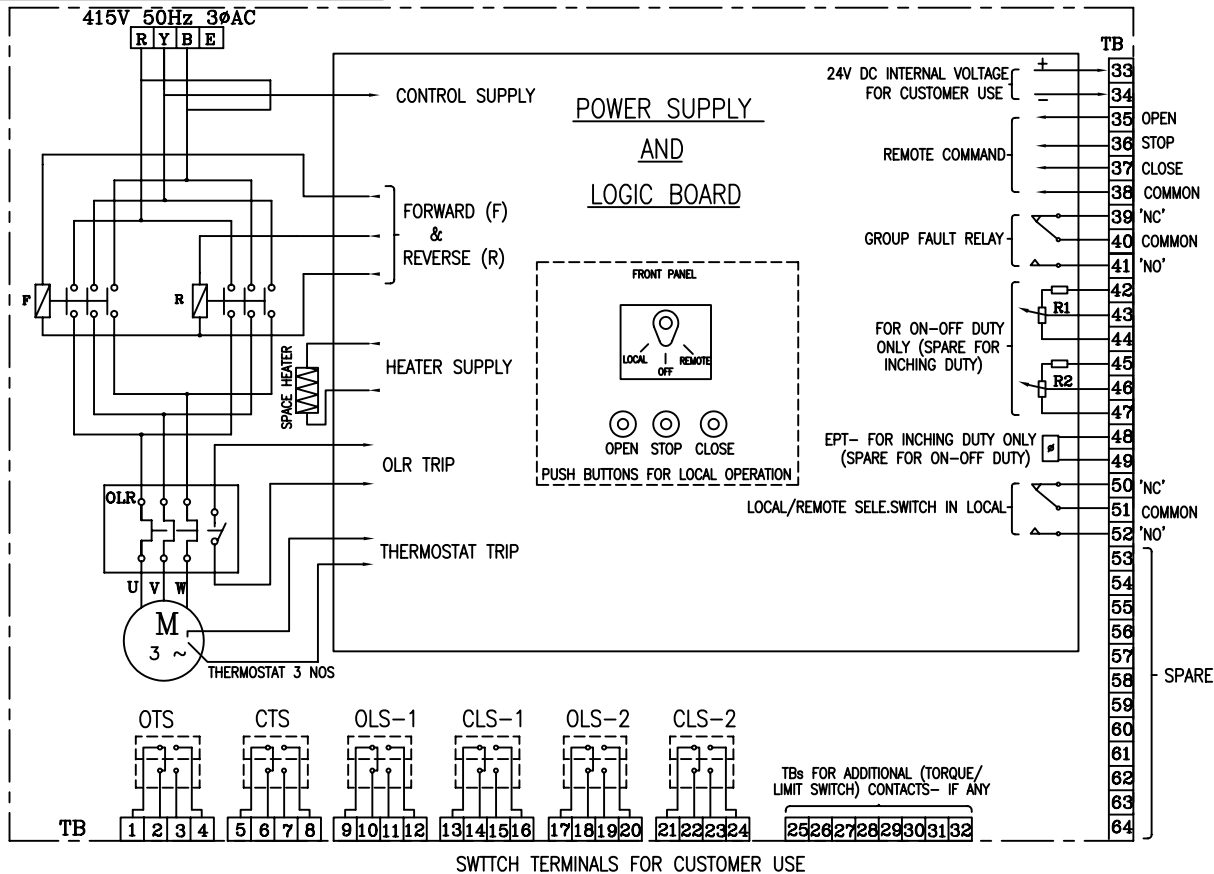

CONTACT DEVELOPMENT DIAGRAM

OTS	1-2	OPEN AT OVER TORQUE DURING OPENING TRAVEL
	3-4	CLOSE AT OVER TORQUE DURING OPENING TRAVEL
CTS	5-6	OPEN AT OVER TORQUE DURING CLOSING TRAVEL
	7-8	CLOSE AT OVER TORQUE DURING CLOSING TRAVEL
OLS-1	9-10	INDICATES CONTACT CLOSED
	11-12	INDICATES CONTACT OPEN
CLS-1	13-14	INDICATES CONTACT CLOSED
	15-16	INDICATES CONTACT OPEN
OLS-2	17-18	INDICATES CONTACT CLOSED
	19-20	INDICATES CONTACT OPEN
CLS-2	21-22	INDICATES CONTACT CLOSED
	23-24	INDICATES CONTACT OPEN
SWITCH	TERMINAL NO.	VALVE POSITION
		FULL OPEN a
		INTERMEDIATE b
		FULL CLOSE

CONTACT RATING: 5A AT 250V AC & 0.5A AT 220V DC

SETTING PROCEDURE OF POSITION LIMIT AND TORQUE SWITCH

VALVES	OPEN		CLOSE	
	MAIN	BACK UP	MAIN	BACK UP
GATE VALVE OF 100 mm AND ABOVE IN 1500 CL AND ABOVE RATINGS	OLS	OTS *	CLS	CTS
ALL OTHER GATE & GLOBE VALVES	OLS	OTS *	CTS	#

- CLS NOT TO BE CONNECTED IN TRIP CIRCUIT
* - BYPASS OTS FOR INITIAL 5% OF TRAVEL (FOR GATE VALVES ONLY)

- NOTE:-
- ALL TORQUE AND LIMIT SWITCHES (OTS,CTS,OLS1&2, CLS1&2) ARE WITH 2NO+2NC CONTACTS '1NO+1NC' IS TERMINATED IN TBS 1-24, REMAINING CONTACTS ARE FOR INTERNAL USE. ANY SPARE CONTACTS WHICH ARE NOT USED INTERNALLY ARE TO BE TERMINATED IN TBS 25-32
 - CTS - TORQUE SWITCHES FOR CW ROTATION (CLOSE)
 - OTS - TORQUE SWITCHES FOR CCW ROTATION (OPEN)
 - OLS-1, OLS-2 - LIMITSWITCHES FOR POSITION OPEN
 - CLS-1, CLS-2 - LIMITSWITCHES FOR POSITION CLOSE
 - EPT - ELECTRONIC POSITION TRANSMITTER (Contactless, FOR INCHING DUTY)
 - R1-R2-POTENTIOMETER 2 x 100 OHMS (FOR ON-OFF DUTY)
 - FOR COMMANDS & EPT EITHER INTERNALLY GENERATED 24VDC OR EXTERNAL SUPPLY OF 24VDC CAN BE USED
 - M - MOTOR 3φ 415V 50 Hz AC SUPPLY

REV	DATE	ALTERED
		CHD & APPD

CAUTION: The information on this document is the property of BHARAT HEAVY ELECTRICALS LTD. It must not be used directly or indirectly in any way detrimental to the interest of the company.

TYPE OF PRODUCT ELECTRICAL VALVE ACTUATORS (AC) WITH INTEGRAL STARTERS
OR NAME OF CUSTOMER/PROJECT (DRAWN FOR INTERMEDIATE POSITION OF VALVES)

	BHARAT HEAVY ELECTRICALS LTD. UNIT: HIGH PRESSURE BOILER PLANT. TIRUCHIRAPALLI-620014.	DRN N.P.ESWAR	SIGN N.P	DATE 07.10.04	NO. OF VAR.
		CHD D.DINAKARAN	D.D	07.10.04	
		APPD K.ARUNACHALAM	K.A	07.10.04	

DEPT VL	SCALE	WEIGHT (KG).	REFERENCE INFORMATION	NO. OF ITEMS
CODE				
TITLE WIRING DIAGRAM (TERMINAL PLAN) FOR ACTUATOR WITH INTEGRAL STARTER	CARD CODE U 01	DRAWING NO. 3-V-MISC-24227	REV 0	



Technical specification for
CONTROL & INSTRUMENTATION

1X800 MW KOTHAGUDEM

SPEC NO.: **PE-TS-410-145-I**

VOLUME

SECTION

REV. NO. 00

DATE : 27.05.2015

SHEET OF

Drive Control Philosophy

DCS INTERFACE FOR BIDIRECTIONAL DRIVE (WITH INTEGRAL STARTER)

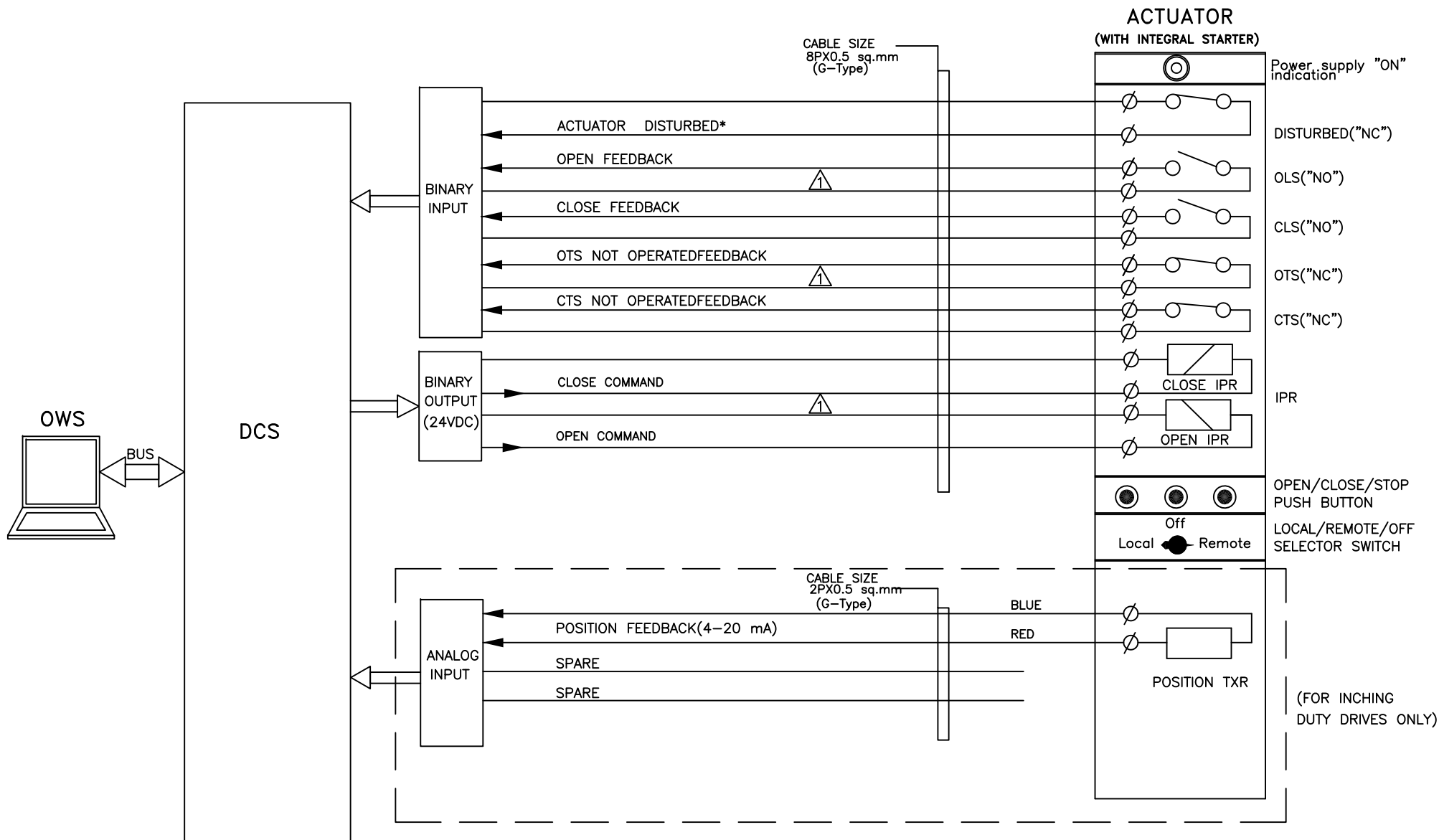

NOTE:

* DISTURBED= Loss of Power supply (1 Phase/3 Phase)/
 Loss of control supply/ Motor thermostat trip/
 Thermal over load/Torque open/close cutoff mode/
 Local/Off/Remote Sel. switch
 Stop PB optd.



PROJECT:	1X800 KOTHAGUDEM TPS STAGE-VII, UNIT-12	DRG.NO.	PE-DM-410-145-1002
		DATE	09.03.2015
TITLE:	DDCMIS INTERFACE FOR BIDIRECTIONAL DRIVE	REV.NO.	01
		SHT	7 OF 11

DCS INTERFACE FOR UNIDIRECTIONAL LT DRIVE

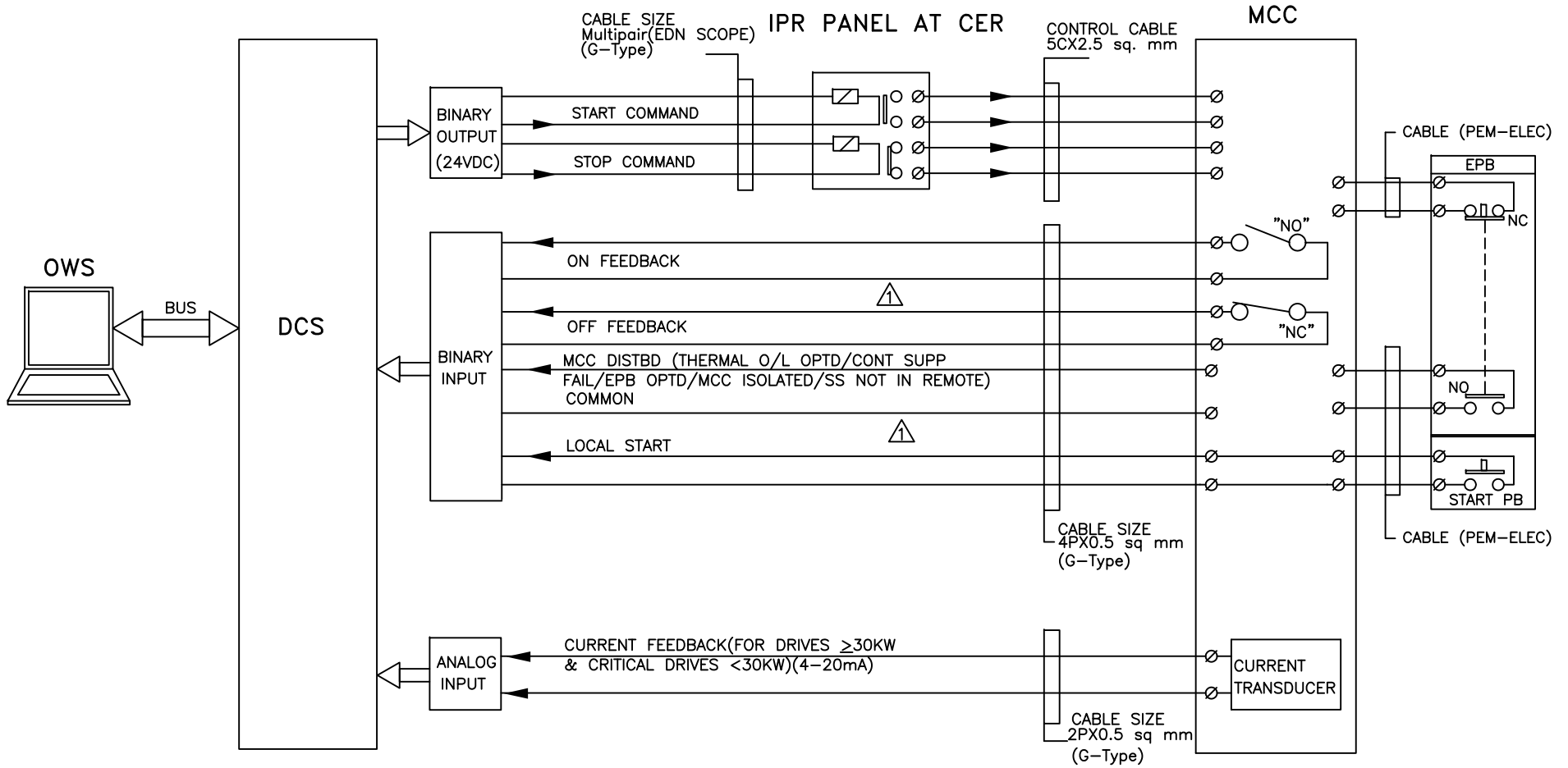

* FOR LTUD DRIVES ALL LUBE OIL PUMPS, SCANNER AIR FANS, SEAL AIR FANS, 4-20mA CURRENT TRANSDUCER SHALL BE CONSIDERED.



PROJECT:	1X800 KOTHAGUEM TPS STAGE-VII, UNIT-12	DRG.NO.	PE-DM-410-145-1002
	TITLE:	DDCMIS INTERFACE FOR UNIDIRECTIONAL LT DRIVE	DATE
		REV.NO.	01
		SHT	8 OF 11



Technical specification for
CONTROL & INSTRUMENTATION

1X800 MW KOTHAGUDEM

SPEC NO.: **PE-TS-410-145-I**

VOLUME

SECTION

REV. NO. 00

DATE : 27.05.2015

SHEET OF

INSTRUMENTATION DATA SHEET

1.00.00 **SPECIFICATION FOR ELECTRONIC TRANSMITTERS**

1.01.00 PRESSURE TRANSMITTER

1. Working Principle : Smart (HART Compatible)
2. Type : Microprocessor based, 2 – Wire
3. Output Signal : 4-20 mA DC along with superimposed digital signal
4. Measuring Element : Capsule / Diaphragm
5. Element material : SS-316 (Stainless Steel) or better
6. Static Pressure : 150 % of maximum span continuously, without affecting the calibration
7. Turn-down ratio : 100: 1
8. Span and Zero : Continuous, tamper proof, remote as well locally adjustable with zero elevation and suppression by 100% of span
9. Enclosure Class : IP-65 (Explosion proof for NEC Class-1, Division 1 area)
10. Output Indicator : LCD (Integral indicator of 5 digit display)
11. Nameplate : Tag number, service engraved in SS tag plate
12. Body : SS
13. Operating Voltage : 24V DC
14. Load : 600 Ohms (min.) at 24 Volts D.C.
15. Ambient Temperature : 0 - 50 °C
16. Performance: :
 - i. Accuracy : $\pm 0.075\%$ of Span or better

- ii. Repeatability : $\pm 0.05\%$ of Span or better
17. Sealing/Isolation : Extended diaphragm (Silicon oil/Fluorolub filled) with 5 meters SS armoured capillary for corrosive/viscous/solid bearing or slurry type fluid applications
18. Accessories :
- a. Universal mounting bracket suitable for 2" pipe mounting
 - b. High tensile carbon steel U-bolts
 - c. Siphon for steam and hot water services
 - d. 1/2" NPT 2-valve stainless steel manifold, constructed from SS316 bar stock
 - e. Companion flange with nuts, bolts and gaskets
 - f. 1/2" NPT cable gland
 - g. Handheld calibrator
19. Adjustment/Calibration/ Maintenance : From handheld calibrator/ HART management system

Notes: For primary air/ secondary air/ flue gas applications, DP type transmitters shall be provided for pressure measurement. LVDT type is not acceptable.

1.02.00 DIFFERENTIAL PRESSURE TRANSMITTER / FLOW TRANSMITTER

- 1. Working Principle : Smart (HART Compatible)
- 2. Type : Microprocessor based, 2 – Wire
- 3. Output Signal : 4-20 mA DC along with superimposed digital signal
- 4. Measuring Element : Capsule / Diaphragm

-
5. Element material : SS-316 (Stainless Steel) or better
6. Static Pressure : 150 % of maximum span continuously, without affecting the calibration
7. Turn-down ratio : 100: 1
8. Span and Zero : Continuous, tamper proof, remote as well locally adjustable with zero elevation and suppression by 100% of span
9. Enclosure Class : IP-65 (Explosion proof for NEC Class-1, Division 1 area)
10. Output Indicator : LCD (Integral indicator of 5 digit display)
11. Nameplate : Tag number, service engraved in SS tag plate
12. Body : SS
13. Operating Voltage : 24V DC
14. Load : 600 Ohms (min.) at 24 Volts D.C.
15. Ambient Temperature : 0 - 50 °C
16. Performance:
- i. Accuracy : $\pm 0.075\%$ of Span or better
 - ii. Repeatability : $\pm 0.05\%$ of Span or better
17. Sealing/Isolation : Extended diaphragm (Silicon oil/ Fluorolub filled) with 5 meters SS armoured capillary for corrosive/viscous/solid bearing or slurry type fluid applications
18. Accessories :
- a. Universal mounting bracket suitable for 2" pipe mounting
 - b. High tensile carbon steel U-bolts

- c. Siphon for steam and hot water services
- d. ½” NPT 5-valve stainless steel manifold, constructed from SS316 bar stock
- e. Companion flange with nuts, bolts and gaskets
- f. ½” NPT cable gland
- g. Handheld calibrator

19. Adjustment/Calibration/ Maintenance : From handheld calibrator/ HART management system

1.03.00 Displacer Type Level Transmitters

- 1. Type : Smart (HART Compatible)
- 2. Stages of operation : Continuous
- 3. Material :
- 4. i. Displacer : SS-316
- 5. ii. Suspension wire : SS-316
- 6. iii. Torque tube housing : SS
- 7. iv. Torque tube : Inconel
- 8. v. Displacer chamber : SS
- 9. vi. Transmitter Housing : SS
- 10. Operating Voltage : 24 V DC
- 11. Transmission : Microprocessor based, 2-wire
- 12. Output Signal : 4-20 mA DC along with superimposed digital signal
- 13. Static / overload : Maximum static pressure without

transmitters. The hand held calibrator shall be suitable for all types of transmitters supplied in the package. If one type of hand held type calibrator is not suitable for communicating with all types of transmitters then separate hand held calibrator will be provided.

3.00.00 **PROCESS ACTUATED SWITCHES**

3.01.00 PRESSURE SWITCH

1. Type :
 - i. Piston for high pressure application
 - ii. Bellow / Diaphragm for low pressure application
2. Sensing element : SS-316.
material All other wetted part SS316
3. Case Material : SS \dagger
4. Setter Scale : Black graduation on white linear scale.
Graduation 0-100% with red pointer for set points
5. Over range : 150 % of maximum pressure
6. Adjustments :
 - a) Internal Set Point
 - b) Differential adjustment
7. End Connection : 1/2" NPT bottom connected
8. Switch configuration : Two SPDT (240V, 5A AC/220V, 0.5A DC)
9. Switch Type : Snap acting, shock & vibration proof
10. Terminal Block : Suitable for full ring lugs
11. Enclosure Class : IP-65 (Explosion proof for NEC Class-1, Division 1 area)
12. Performance :
 - a) Repeat accuracy \pm 1.0%
 - b) Accuracy of Setting Indication of \pm 1.5%
13. Ambient temperature : 0 – 50 Deg.C

-
14. Nameplate : Tag number, service engraved in SS tag plate
15. Accessories : a) Silicon oil/ Fluorolub filled Remote diaphragm seal with SS-316 capillary for corrosive/ viscous/ solid bearing or slurry type fluid applications
b) Snubbers for pulsating fluid applications
c) Siphons for steam and hot water services
d) Retention ring and screws for surface mounting
e) 1/2" NPT 2 Valve SS-316 barstock manifold
f) 1/2" NPT cable gland
16. Applications : During Detail Engineering on Owner's approval

3.02.00 DIFFERENTIAL PRESSURE SWITCH

1. Type : i. Piston for high pressure application
ii. Bellow / Diaphragm for low pressure application
2. Sensing element material : SS-316.
All other wetted part SS316
3. Case Material : SS
4. Setter Scale : Black graduation on white linear scale. Graduation 0-100% with red pointer for set points
5. Over range : 150 % of maximum pressure

-
- | | | |
|-------------------------|---|--|
| 6. Adjustments | : | a) Internal Set Point |
| | : | b) Differential adjustment |
| 7. End Connection | : | 1/2" NPT bottom/ back connected |
| 8. Switch configuration | : | Two SPDT (240V, 5A AC/220V, 0.5A DC) |
| 9. Switch Type | : | Snap acting, shock & vibration proof |
| 10. Terminal Block | : | Suitable for full ring lugs |
| 11. Enclosure Class | : | IP-65 (Explosion proof for NEC Class-1, Division 1 area) |
| 12. Performance | : | a) Repeat accuracy $\pm 1.0\%$ |
| | | b) Accuracy of Setting Indication of $\pm 1.5\%$ |
| 13. Ambient temperature | : | 0 – 50 Deg.C |
| 14. Nameplate | : | Tag number, service engraved in SS tag plate |
| 15. Accessories | : | a) Silicon oil/ Fluorolub filled Remote diaphragm seal with SS-316 capillary Diaphragm seals for corrosive/ viscous/ solid bearing or slurry type fluid applications |
| | | b) Snubbers for pulsating fluid applications |
| | | c) Siphons for steam and hot water services |
| | | d) Retention ring and screws for surface mounting |
| | | e) 1/2" NPT 5 Valve SS-316 barstock manifold |
| | | f) 1/2" NPT cable gland |
| 16. Applications | : | During Detail Engineering on Owner's approval. |

~~approval~~

4.00.00 **LOCAL INSTRUMENTS**

4.01.00 PRESSURE GAUGE AND DIFFERENTIAL PRESSURE GAUGE

1. Type : Bourdon/Bellows/Diaphragm
2. Sensing & Socket : SS-316
3. Movement Material : SS-316
4. Case Material : Stainless steel. IP-65 (Explosion proof for NEC Class-1, Division 1 area)
5. Dial Size : Generally 150 mm
6. Scale : Black lettering on white in 270 O arc.
7. Window : Shatterproof glass
8. Range Selection : Normal process pressure: 50~70 % of range
9. Over-range Protection : 125% of maximum range by internal stop. External stop at zero
For Zero adjustment (Micrometer screw external)
10. Adjustment : For Range adjustment (Micrometer screw internal).
11. Element Connection : Argon welding
12. Process Connection : 1/2" NPT (M) Bottom for local, back for panel mounting
13. Performance : Accuracy of ± 1.0 % of span or better
14. Operating ambient : 0 - 50 °C
15. Safety Feature : Blow out disc /diaphragm at the back
16. Accessories :
 - a) Snubbers for pulsating fluid application.discharge
 - b) Stainless steel Diaphragm seals

for corrosive/ viscous/ solid bearing or slurry type fluid applications

c) 3-Way SS316 Gauge cock for pressure gauges

d) 5-valve SS316 manifold from barstock for differential pressure gauge

e) Siphons for steam and hot water services

17. Nameplate : Tag number, service engraved in stainless steel tag plate

4.02.00 LEVEL INDICATOR (FLOAT & BOARD TYPE)

1. Type : Float and Board
2. Float Material : SS-316
3. Float Cable : SS-316
4. Indicator Assembly : Epoxy painted Aluminium
5. Guide wire spring assembly : SS-316 (2 Nos.)
6. Guide Wire Anchor : SS-316
Anodized Aluminium with engraved marking (Minimum graduation 10mm),
7. Scale Board :
mounting brackets and suitable hardware required as per tank height
8. Elbow Assembly : Anodized Aluminium
9. Flanges : RF , ANSI 150 , SS (3 Nos.)
10. Accuracy : ± 10 mm or better
11. Accessories : All mounting accessories including counter flange, nuts & bolts, suitable



Technical specification for
CONTROL & INSTRUMENTATION

1X800 MW KOTHAGUDEM

SPEC NO.: **PE-TS-410-145-I**

VOLUME

SECTION

REV. NO. 00

DATE : 27.05.2015

SHEET OF

LCP and JUNCTION BOXES SPECIFICATION

- 1.00.00 **GENERAL REQUIREMENT**
- 1.01.00 ENCLOSURES FOR INSTRUMENTS AND OTHER EQUIPMENT
- 1.01.01 All panels, cabinets, distribution boxes, junction boxes, terminal boxes and all other field mounted equipment / enclosures shall have suitable environmental protection as detailed in Section-I of this volume of the specification.
- 1.02.00 SURFACE PREPARATION & PAINTING
- 1.02.01 All sheet metal panel/ desk exterior steel surfaces shall be sand blasted, ground smooth and painted as specified below.
- 1.02.02 Suitable filler shall be applied to all pits, blemishes and voids in the surface. The filler shall be sanded so that surfaces are level and flat; corners are smooth and even. Exposed raw metal edges shall be ground burr-free. The entire surface shall be blast clean to remove rust and scale and all other residue due to the fabrication operation. Oil, grease and salts etc. shall be removed from the panels by one or more solvent cleaning methods prior to blasting.
- 1.02.03 Two spray coats of inhibitive epoxy primer surfacer shall be applied to all exterior and interior surfaces, each coat of primer surfacer shall be of dry film thickness of 1.5 mil. A minimum of two spray coats of final finish color (Catalyzed epoxy or polyurethane) shall be applied to all surface of dry film thickness 2.0 Mil. The finish colors for exterior and interior surfaces shall conform to the following shades:
- Exterior – Opaline green shade 275 of IS: 5 or equivalent international code..
 - Interior - Brilliant White.
- 1.02.04 Paint films, which show sags, cheeks, blisters, teardrops, fat edges or other painting imperfections, shall not be acceptable.
- 1.03.00 WIRING
- 1.03.01 All spare contacts of relays, switches and push buttons shall be wired up to the terminal blocks. All intercommunications between sections of panels/desks shall be furnished.
- 1.03.02 Each wire shall be identified at both ends with wire designation as per approved wiring diagram. Heat shrinkable type ferrules with indelible computerized ink print shall be used with cross- identification.
- 1.03.03 All wire termination shall be made with insulated sleeve and crimping type lugs. Wire shall not be spliced or tapped between terminals. Open-ended terminal lugs will not be accepted. Wires shall not be looped around the terminal screws or studs.

- 1.03.04 Internal wiring should be terminated uniformly on one side of the terminal block leaving the other side available for termination of outgoing cables. Internal wiring shall be grouped so that all outgoing wiring to each particular remote location is terminated on adjacent terminal blocks. Interior wiring and jumperings shall be arranged so that external connections can be made from internal side of terminal blocks. Common connections shall be limited to two (2) wires per terminal.
- 1.03.05 Wiring shall be arranged to ensure free access to all instrument or devices for maintenance. No wire shall be routed across the face or rear of any device in a manner, which will impede the opening of covers or obstruct access to leads, terminals or devices
- 1.03.06 Wires shall be dressed and run in trays or troughs with clamp-on type covers. Wirings may be neatly bunched in groups by non-metallic cleats or bands. Each group shall be adequately supported along its run to prevent sagging or strain on termination.
- 1.03.07 Shield wires shall be terminated on separate terminal blocks. Common connections shall be limited to two wires per terminal. Signal circuit shields shall be grounded at the power supply end only or as recommended by manufacturer.
- 1.03.08 All low level signal cables shall be separately bundled to from control cable and maintained at 300 mm minimum spacing from control bundles.
- 1.03.09 Panel internal wiring shall follow distinct color-coding to segregate different voltage levels viz. 24V DC, 48V, 110V AC, 240V AC, 220V DC etc.
- 1.03.10 Thermocouple lead wires, analyzer measuring lead wires, or any other lead wires carrying measuring signal of the order of low milli volt or micro volt shall be electrically and physically isolated from other AC and DC wiring. Shielded wires used in such cases for panel internal wiring shall be continuous and ungrounded with the shield terminated individually and separately in panel terminal block.
- 1.03.11 Wiring to door mounted devices shall be provided with multi-strand wires of (49 strands minimum) adequate loop lengths of hinge-wire so that multiple door openings will not cause fatigue failure of the conductor.
- 1.03.12 Internal wiring in factory pre-wired electronic systems cabinets may be installed according to the Contractor's standard wire size, insulation, and method of termination on internal equipment. Insulation for all wiring, including circuit board wiring, back panel wiring, power supply wiring and interconnecting cables between devices shall pass the vertical flame test per IPCEAS-1981. Identification of conductors may be done by insulation color-coding identified on drawings or by printed wiring lists.

- 1.04.00 TERMINAL BLOCKS
- 1.04.01 All terminal blocks shall be rail mounted/ post mounted type, cage clamp type with high quality non-flammable insulating material of melamine suitable for working temperature of 105 Deg C. The terminal blocks in field mounted junction boxes, instrument enclosures racks etc. shall be suitable for cage clamp connections. The terminal blocks in Control Equipment Room termination/ marshalling cubicles shall be suitable for post mounted cage clamp connection at the field input end. The exact type of terminal blocks to be provided by Bidder shall be subject to Owner.
- 1.04.02 All terminal blocks shall be provided complete with all required accessories including assembly rail, locking pin and section, end brackets, small partitions, transparent covers, support brackets, distance sleeves, warning level, marking etc. For RTDs ring - tong type lugs shall be used at Junction Boxes.
- 1.04.03 The characteristics of the terminal blocks shall be as follows.
- i) High contact force, independent of conductor cross-section and large contact surface area.
 - ii) Integrated self-loosening protection to avoid shifting of contact surface that may allow contamination of connection point.
 - iii) Inspection and maintenance free (resistant to thermal aging and vibration)
 - iv) Low and constant voltage drop
- 1.04.04 The insulation of the terminal blocks shall be of suitable thermoplastic material.
- 1.04.05 The spacing between Terminal blocks channels in panels and cubicles shall be adequate for routing the cable troughs and to allow adequate free workspace for termination and removal of wires. The terminal blocks shall be arranged with atleast 100 mm clearance between two sets of terminal blocks and junction box walls.
- 1.04.06 Signals of different voltage levels shall be clearly segregated by providing separate rows to each type of signal and by using terminal blocks of different color for each type of signal and by providing barrier strips between them.
- 1.04.07 Terminal blocks shall be provided with white marking strips / self-adhesive marker cards and where permitted by the safety codes and standards, shall be without covers. Power terminals and high voltage (above 48 volts) terminals shall have protection covers. All terminals shall be provided with permanent terminal identification numbers on both sides.
- 1.04.08 At least 20% spare unused terminals shall be provided on each terminal block for circuit modifications and for termination of all conductors in a multi-conductor control cable.

- 1.04.09 The bottom of the terminal block shall be at least 200 mm above the cable gland for bottom entry type panels.
- 1.04.10 For extending 24 V DC supply to panels, the size of the terminals shall be decided based on voltage drop and not based on current.
- 1.04.11 Other requirements of the terminal blocks are as follows:
- i) The last terminal in a rail-mounted assembly shall be closed with an end plate and end bracket.
 - ii) For visual and electrical separation of terminal groups, partition plates shall be provided, which can be push fitted after forming an assembly.
 - iii) Design shall permit testing of incoming and outgoing signals by using suitable test plug and socket without disconnecting the cable connections.
 - iv) It shall be possible to use jumper plugs through the above test plug socket to connect adjacent terminals. Adequate number of short circuit jumper plugs shall be provided for the purpose.
 - v) Where more than one connection to a terminal block is required, two tier terminals shall be used.
- 1.05.00 **GROUNDING**
- 1.05.01 Separate Protective and Electronic system ground as required shall be provided.
- 1.05.02 All panels, desks, cabinets shall be provided with a continuous bare copper ground bus (Frame ground), bolted to the panel structure at bottom on both sides and effectively ground the entire structure. The bolts shall face inside of panels.
- 1.05.03 For electronic system cabinets the electronic system ground bus (Electronic ground) shall be similar but insulated from the cabinet and shall be separately connected to the system ground .The same ground may be used to earth the shield of shielded signal cables, otherwise a separate ground bus shall be provided for connecting the signal cable shields. Cable shields shall be grounded at the panel end only and shall never be left open .The electronic ground between panels of a shipping section shall be firmly looped.
- 2.00.00 **CONTROL DESKS & PANELS**
- 2.01.00 **GENERAL**
- 2.01.01 All control desk, panels etc. shall be furnished fully wired with necessary provision for convenience outlets, internal lighting, utility receptacles, grounding, ventilation, space heating, anti-vibration pads, internal piping &

- accessories as required for completeness of the system.
- 2.01.02 The design shall conform to the EN ISO 11064 (Ergonomical design of Control Room), Part 1, 2 and 3.
- 2.01.03 The exact dimensions, material, construction details, grounding, general arrangement etc. shall be as per actual requirement and shall be finalized during detail engineering and subjected to Owner's approval.
- 2.01.04 Incoming power supply feeders shall be duplicated. Alarm shall be provided for failure of a power supply feed.
- 2.01.05 For Control desk/ panel mounted instruments/ devices etc. which are to be powered from UPS, all required conversion of interface equipments/ accessories to make such devices compatible with UPS supply shall be provided. All necessary hardware like input switches/ fuse unit for each feeder as well as switch fuse unit for each instrument/ device on the power supply line shall be provided. From UPS redundant feeders shall be provided with suitably rated MCB and provision of fast auto changeover of UPS feeders.
- 2.01.06 Crating of the panels and desks shall be suitable for protection against shock, vibration, inappropriate handling and inclement weather conditions during transportation and warehousing. Mounted equipment shall have adequate protection against damage during handling, transit and storage. Suitable desiccant shall be used inside the packing case.
- 2.01.07 Nameplate
- a) Nameplate shall be provided for instrument or device mounted on the panel.
 - b) Nameplates for panels shall be provided both in front and rear.
- 2.02.00 CONTROL DESK
- 2.02.01 Control desk shall be free standing, floor mounting, table top type with doors at back and shall be constructed of 3 mm thick (minimum) CRCA steel or Aluminium extrusion. Aluminium structure shall be anodized or powder coated paint finish. The top surface of control desk shall be 30 mm (minimum) thick with the top 12 mm (minimum) of acrylic solid surface and the remaining 18 mm of laminated medium density fibre (MDF) board.
- 2.02.02 Monitors with retractable keyboard shall be provided on the desk. Desk shall be arranged in arc-like shape without any sharp edges. Edges shall be extruded PVC or rounded post-formed laminate.
- 2.02.03 Desks shall be of modular, scalable and industrially ruggedized design and shall have connections for PA system handsets & telephone sets.
- 2.02.04 Desks shall have concealed cable trays for wire dressing. Both Horizontal & Side Managers (2 separate horizontal cable routing wire baskets for power & data cables) shall be provided.

Each User station will be provided with 2 separate power distribution units (1 for Main line & 1 for UPS line). Each power distribution unit will have 6 points of 5/13 Amp sockets, Mains MCB On/Off Switch & Indicator.

Adequate heat management provision for Exhaust of heat from within the Console Desk Assembly shall be provided. There will be multiple fans provided in the Main Control Desk. Each Fan will be of 230 VAC 250 CFM Ball Bearing based. Ventilation louvers will be provided on both Front & Rear Modesty with special Air Filters. Adequate space for CPU & Other equipments placed with in the desk.

2.02.05 Design shall include Earthing bolts.

2.02.06 Back installed items shall be suitably concealed from front view.

2.02.07 All operator workstations for SG, TG, Auxiliaries & Off-site Plants shall be mounted on this Control Desk. The cabling / wiring between OWS & CPUs, power supply cables etc. shall be aesthetically routed and concealed from view.

2.02.08 HARDWIRED DEVICES ON CONTROL DESK (DRAW OUT SECTION)

Release and Lamp Test push buttons shall be provided for a set of push buttons (decided during detail engineering stage). Depending on the type of control/ function, required number of push buttons/ indicating LEDs & their color, push button stations shall be selected. The size of push button stations shall be 24 x 48 mm or 25 x 50 mm and shall have service inscription details at the front. Emergency push buttons (with cover) shall be mounted on top of Control Desk.

2.03.00 ~~BACK UP PANEL~~

2.03.01 ~~Construction shall be from CRCA steel of thickness not less than 3mm.~~

2.03.02 ~~Upright back-up panel shall be provided where hardwired devices shall be mounted on a mosaic grid type console. The mosaic grid tiles shall be of 24 mm x 48 mm (or 25 mm x 50 mm) size, made of heat & flame retardant, self extinguishing and non-hygroscopic material with flat matt finish without glare and non reflecting type.~~

2.03.03 ~~DDCMIS Back-up Panel (referred as Unit Control Panel-UCP) shall also mount annunciation fascia (minimum 500 nos.) and the flame monitoring cameras along with other hardwired devices as decided during detail engineering stage by Owner. Color coding shall also subject to Owner's approval.~~

2.03.04 ~~Colored Mimic for different Off-site plant control systems (as enumerated elsewhere in this specification) and hardwired annunciation system shall also~~

be mounted on the back up panels.

2.04.00 PANELS/CABINETS

2.04.01 All DDCMIS system modules, power supply components and other Local Control panels (PLC/Relay based) shall be housed in cabinets as specified below.

2.04.02 The cabinet mounted equipments shall be fully assembled, installed in mounting racks, wired and fully tested as per specification requirements and Owner approved drawings prior to shipment to the project site.

2.04.03 The Bidder shall ensure that the cabinets are complete & ready for installation before dispatch from manufacturing works. The installation work at project site for these cabinets shall only involve connections through multi-pair cables from marshalling cabinets (wherever provided) to system cabinets and inter-cabinet/cabinet to Control Desk/ Back up Panel.

2.04.04 All electronic cards, network components, power supply modules etc. located shall be suitably housed in cabinets and shall be neatly arranged in sub-racks. Network components shall be visible in door closed condition (e.g. Glass doors etc.) as approved by Owner.

2.04.05 Bidder shall design the cabinet internal arrangement, floor cutout and cable gland plate such that all the cables entering or leaving the cabinet can be properly glanded in the gland plate.

2.04.06 The packaging density of panels shall be such that the temperature rise within the panels shall never exceed 10°C above ambient even under worst operating conditions. Cooling Fans shall be provided wherever required and this shall be of industrial grade.

2.04.07 TECHNICAL PARTICULARS

1. Material of Construction : Cold Rolled Coal Annealed (CRCA) steel sheet
2. Thickness of Sheet : a) 2.0 mm for faces supporting instruments / terminals
: b) 1.6 mm for other sides and top
3. Construction : Welded throughout as per approved National Standards
4. Post welding operation : a) Grounding of all welds to smoothness
: b) Rounding of corners

- : c) Cleaning of weld spatters
- 5. Panel height : 2300 mm (approx)
- 6. Corners : 7 mm inner radius
- 7. Dimensional Tolerances :
 - a) In height & length - 3 mm
 - b) In height between adjacent sections - 2 mm
 - c) Total for a group - 6 mm
- 8. Doors : Double, recessed, turned back edges, full height front & rear
 - i) Thickness of Sheet : 2 mm
 - ii) Hinges : Stainless steel
 - iii) Door latches : Three point type
 - iv) Door gaskets : Neoprene rubber on fixed frame to result dust proof/weatherproof enclosure
 - v) Opening of the doors : Outward
 - vi) Louvers : With removable wire mesh to ensure dust and vermin proof
- 9. Gland plates : Removable in sections
4 mm thick (bottom)
- 10. Cable entry : Bottom
- 11. Hardware :
 - a) Anti vibration pad- 15 mm
 - b) Predrilled base channel ISMC – 100 or equivalent for all sides
 - c) Stainless steel buff- finished 2 mm thick kick plate for all sides
 - d) Stainless steel scratch strips along desk edges fixed with pan-head recessed screws
 - e) Rubber strips to ensure air

- tightness between kick plate and finished floor
- f) Lifting hook / Eye bolt
- g) Drawing pocket
- h) Door switch, lamps, thermostat, heaters and industrial grade cooling fans,, illumination fixtures
12. Name Plate : Both at front and back surface of the panel
13. Fixing of name plate : Stainless steel pan head screws
14. Name plate material : Laminated phenolic (3 layers)
15. Lettering : Black with white engraved
16. Mounting of terminal blocks : Vertical angle support bracket tack welded on sheet steel plate, screwed on internal wall of enclosure

2.05.00 FURNITURE

All the furnitures in the Central / Local control Room (s), Engineers' rooms, Instrument laboratory , SWAS Room & any other rooms with C&I equipments located in different plant buildings under Bidder's scope shall be included in Bidder's scope of supply. Bidder shall provide following industrial grade furniture items as a minimum from reputed manufacturers/suppliers meeting International Standards. The furniture shall be modular and latest with ease of operational features. The furniture shall be modern, aesthetically designed, modular, flexible, space saving and future safe.

2.05.01 WORK STATION FURNITURE

Modular work station furniture, suitable for mounting servers & historians, programmer stations, PC based systems, printers (A4/A3 color laserjet) etc. shall be provided.

2.05.02 PC RACK

PC Racks shall be provided to mount CPUs of workstations/PCs of OWS/LVS etc. in control room. For each PC / workstation / monitor at least one chair shall be included.

2.05.03 CHAIRS

Industry standard revolving chairs with wheels and with provision for adjustment of height (hydraulically/gas lift) shall be provided for the operators, unit-in-charge & other personnel in control room area. These shall be designed for sitting for long duration such that these are comfortable for the back.

2.05.04 TABLES

Industry standard computer tables shall be provided & shall be as approved by Owner during detailed Engineering. Glass top teak wood horse shoe shaped table with vertical file mounting arrangement (two layers to house approx. 40 Nos of files and lockable drawers at both ends) for Engineering Room shall be provided.

2.05.05 ALMIRAHS

Steel Almirahs shall be provided for keeping documents in the documentation room. Glass doors for each rack shall be provided such that the documents are visible from outside. Size of the rack shall be sufficient to easily fit technical manuals. The exact details shall be approved by Owner during detailed Engineering.

2.05.06 KEYPAD

One keypad per unit shall be provided for the storing of keys of relevant areas of the unit in the control room.

2.05.07 LOCKERS

Suitable lockers shall be provided in the room adjacent to the control room for storing of personal articles of control room personnel. Also, lockers of bigger size shall be provided in documentation Room for storing of personal documents. Details shall be finalized and approved by Employer during detailed engineering.

3.00.00 **LVS PANEL**

3.01.00 An arc shaped Large Video Screen (LVS) panel shall be supplied for mounting large video screens in number of tiers in various Control rooms as specified elsewhere in this specification.

Bidder shall provide and fix ACP cladding around the LVS screen including covering the LVS back side and LVS stand. The cladding will be from floor finish to 600 mm above LVS screen like a self-standing partition with necessary openings for system requirement. ACP paneling shall be with 304 grade & approx. 0.5 mm mirror finish SS strip.

3.02.00 The profile, dimensions and the general arrangement shall be finalized & approved by Owner during detailed engineering. Recommendations, if any, for the control room lighting in order to ensure continuous proper viewing of the LVS screen by the operator & shift incharge (without any fatigue) shall be

- clearly brought out by the Contractor in his offer, alongwith all relevant details/basis.
- 3.03.00 Any other requirement for proper LVS mounting & functioning & viewing shall also be specifically brought out by the Contractor in his offer, along with all relevant details.
- 4.00.00 **LOCAL INSTRUMENT RACK (LIR) & LOCAL INSTRUMENT ENCLOSURE (LIE)**
- 4.01.00 GENERAL
- 4.01.01 Devices (Transmitters/ Switches) located in the field shall be suitably grouped together to the extent possible and installed in the LIE (Closed Rack) and LIR (Open Rack) in Boiler/TG Building and Off-site plant areas.
- 4.01.02 Racks and enclosure shall be factory prefabricated & painted and shall complete with internal piping, tubing, manifold, isolation valves, blowdown valves, integral junction box, illumination etc.
- 4.01.03 No more than six instruments shall be grouped in a single rack / enclosure.
- 4.01.04 Racks shall be installed above the tapping points for air, flue gas and coal air mixture application whereas for applications such as for water and steam, racks to be installed below the source point.
- 4.01.05 Attention shall be paid in the layout to avoid air traps in liquid piping and water accumulation in air /gas piping.
- 4.01.06 Racks used for furnace, flue gas and air application shall be provided with intermittent & continuous air purging
- 4.01.07 Welding of impulse lines shall comply with the provisions of the latest applicable ANSI Code for Pressure Piping.
- 4.01.08 Earth stud shall be furnished at rack for safety grounding.
- 4.02.00 LOCAL INSTRUMENT ENCLOSURE (LIE)
- 4.02.01 Enclosure shall be free standing type. Racks shall be adequately reinforced to ensure true surfaces and to provide support. Major load - bearing posts shall be suitably supported by gusset plates or moment members.
- 4.02.02 Enclosure outer shall be constructed from at least 3 mm thick steel plate and epoxy painted to shade gray. Base frame shall be made of ISMC 100 and black colour finish.
- 4.02.03 2" NB galvanized pipes shall be laid horizontally and supported at two end channels to mount transmitters at accessible height. Center posts or any

- member, which would reduce access, shall be avoided.
- 4.02.04 Double leaf interlocking front opening doors with three point locking shall be provided and shall be arranged for maximum possible access to the interior. Key shall be of identical for all enclosures.
- 4.02.05 Doors shall have concealed quick removal type pinned stainless steel hinges and locking handles. Gaskets shall be used between all mating sections to achieve dust and weather proof enclosure rated for IP-65 including the internal junction box. All enclosures shall have access doors on front side.
- 4.02.06 Removable type bulkhead plates of thickness not less than 6 mm shall be mounted at the racks with suitable high temperature gasket. Impulse lines within the enclosures shall be properly clamped.
- 4.02.07 All internal wirings between the instruments and junction box shall run through flexible conduits. No exposed wirings within transmitter racks both open and closed type, is admissible.
- 4.02.08 Racks shall have a common blowdown drain header, which will connect individual instrument blowdown line after suitable pressure breaking through regulating globe type blowdown valves. Covered funnels shall be used for saturated liquid and steam service, whereas, open funnels may be used for cold liquid services. Header (2" NB ASTM A 106, Sch-80 Gr. C) shall be suitably sloped and shall have one end flanged and extending beyond the rack for connection to plant drain header..
- 4.02.09 Each rack shall be provided with one receptacle, light fixtures with wire guard and one lighting switch each at instrument & Junction box compartments with wire guard. Lighting switches may be door actuated & mounted inside the panel. Outlet box, switch box and device covers shall be of galvanized stamped steel. Light switches and receptacles shall be installed inside the enclosure on the wall near the latch side of the enclosure door. Light fixtures shall be installed on the ceilings of the enclosures.
- 4.02.10 Power supplies for miscellaneous devices shall be provided with MCB located within the enclosures. MCB shall be mounted in fuse blocks. Nameplates shall be furnished above the MCB blocks, identifying the devices being served.
- 4.02.11 Vibration dampeners shall be installed for supporting each enclosure. The loading at each corner of the enclosure shall be determined by actual test weighting when construction is complete to determine the correct length of each dampener for proper loading of the dampener in accordance with manufacturer's recommendations
- 4.03.00 LOCAL INSTRUMENT RACK (LIR)
- 4.03.01 Rack shall be free standing type constructed from 6 mm thick steel channel frame provided with a canopy to protect the instrument from dripping water or

falling objects and shall be epoxy painted. Canopy shall be of CRCA steel sheet of at least 3 mm thickness.

4.03.02 Rack Major load-bearing posts shall be suitably supported by gusset plates or moment members. Suitable fenders grill shall be welded to the end-posts of the rack to outline a boundary beyond which no mounted equipment shall project to protect instrument from accidental contact during personnel movement. Center posts or any member, which would reduce access, shall be avoided.

4.03.03 2" NB galvanized pipes laid horizontally and supported at two end channels shall be employed at working accessible height for mounting of instruments.

4.03.04 All internal wirings between the instruments and junction box shall run through flexible conduits. No exposed wirings are admissible.

4.03.05 Racks shall have a common blowdown drain header, which will connect individual instrument blowdown line after suitable pressure breaking through regulating globe type blowdown valves. Covered funnels shall be used for saturated liquid and steam service, whereas, open funnels may be used for cold liquid services. Header (2" NB ASTM A 106, Sch-80 Gr. C) shall be suitably sloped and shall have one end flanged and extending beyond the rack for connection to plant drain header..

Each rack shall be provided with one receptacle, one light fixture with wire guard and one lighting switch. Outlet box, switch box and device covers shall be galvanized stamped steel. Light fixtures shall be installed on the canopy of the rack

4.03.06 Power supplies for miscellaneous devices shall be provided with MCB located within the enclosures. MCB shall be mounted in fuse blocks. Nameplates shall be furnished above the MCB blocks, identifying the devices being served.

4.04.00 JUNCTION BOX

1. Type of Enclosure : Dust tight & weatherproof conforming to IP 65
2. Material : 3 mm sheet steel / fiberglass reinforced polyester(UV stabilized)
3. Type of Cover : Solid unhinged with retention chain / Screwed at all four corners
4. Paint :
 - i) Exterior : Opaline green shade 275 of IS: 5
 - ii) Interior - Brilliant Glossy White.

- Surface / Two (2) inch Pipe stanchion
5. Mounting : (At a dry compartment at one side of the enclosure / rack with front opening type door)
6. Cable Entry : 3 mm (min) Bottom / side Gland plate
7. Gasket : Neoprene
8. Grounding : Brass earth lug with green screw head
External-2 nos , Internal-1no. (M6)
9. Number of Drain Holes : Two at bottom capped
10. Identification : Label for JB and Tags for cable
11. Accessories : Rail mounted cage clamp type screwless terminals (suitable for conductor size up to 2.5sq.mm of suitable voltage grade) with markers and 20% spare terminals
- b) Cable gland (Brass) & raceways
 - c) Ferrules & lugs (Brass)
 - d) Aluminum back panel
 - e) Canopy at top
 - f) Mounting brackets
 - g) bolts and nuts made of brass etc.



DATA SHEET FOR LOCAL PANELS

SPECIFICATION NO.: PE-SS-999-145-054A

VOLUME

SECTION

REV. NO. 02

DATE: 16.09.2013

SHEET 1 OF 3

TAG No. Qty.....

Data Sheet No.: PES-145A-DS1-0

Data Sheet A & B

DATA SHEET-A FOR LOCAL PANEL
(TO BE FILLED BY PURCHASER)

DATA SHEET-B
(TO BE FILLED-UP BY
BIDDER)

GENERAL	MANUFACTURER	
	CONSTRUCTION	<input checked="" type="checkbox"/> FOLDED <input type="checkbox"/> WELDED
	ENCLOSURE SHEET THICKNESS (As per Section 8.13, Volume V of contract specification)	FRONT <input type="checkbox"/> 2.0 mm
		OTHER <input type="checkbox"/> 2.0 mm
		DOOR <input type="checkbox"/> 1.6 mm
		HEIGHT <input type="checkbox"/> 2365 mm for stand alone panels. <input type="checkbox"/> Other
		OTHER <input type="checkbox"/> Load bearing sheet front shall have 3mm thickness
TECHNICAL	INPUT POWER SUPPLY * (As per Electrical specification) (ANY OTHER POWER REQUIREMENT TO BE DERIVED FROM THIS SUPPLY ONLY)	<input type="checkbox"/> 240V 50 Hz AC <input type="checkbox"/> 220V DC <input checked="" type="checkbox"/> 415V 3 PHASE 3W <input type="checkbox"/> 400V 3 PHASE 4W
	NO. OF FEEDERS (As per Electrical specification)	<input type="checkbox"/> ONE <input type="checkbox"/> TWO
	STARTER WITH MCC	<input type="checkbox"/> REQUIRED <input checked="" type="checkbox"/> NOT REQUIRED
	IPR POSITION	<input checked="" type="checkbox"/> MCC <input type="checkbox"/> RELAY PANEL
	CONTACT RATING OF RELAY	<input checked="" type="checkbox"/> 5 Amp, 230 V AC <input checked="" type="checkbox"/> 0.25 Amp, 220V DC
	CONTROL SUPPLY	<input type="checkbox"/> 110V AC <input type="checkbox"/> 220V AC <input type="checkbox"/> 220V DC <input type="checkbox"/> Other. (As per requirement)
	ALARM ANNUNCIATOR WINDOW (EXCLUDING SPARES)	_____ NOS. (AS REQUIRED)
	TEMP SCANNER (IF REQUIRED –NO. OF CHANNELS TO BE SPECIFIED UNDER SEC-C)	<input type="checkbox"/> REQUIRED <input checked="" type="checkbox"/> NOT REQUIRED
	PAINT TYPE (As per Annex-1, Section 7.6, Volume IV of contract specification)	<input type="checkbox"/> EPOXY ENAMEL <input type="checkbox"/> EPOXY POWDER COATED
	MIMIC (TYPE OF MIMIC- MATERIAL, THICKNESS TO BE SPECIFIED DURING DETAILED ENGG.)	<input checked="" type="checkbox"/> REQUIRED <input type="checkbox"/> NOT REQUIRED
	PANEL COLOUR (EXTERNAL) (As per Annex-1, Section 7.6, Volume IV of contract specification)	<input type="checkbox"/> LIGHT GREY <input type="checkbox"/> OPALINE GREEN
	FINISH (EXTERNAL) (As per Annex-1, Section 7.6, Volume IV of contract specification)	<input type="checkbox"/> MATT <input type="checkbox"/> GLOSSY <input type="checkbox"/> SEMI GLOSSY
	PANEL COLOUR (INTERNAL) (As per Annex-1, Section 7.6, Volume IV of contract specification)	<input type="checkbox"/> WHITE <input type="checkbox"/> CREAM <input type="checkbox"/> OFF WHITE
	FINISH (INTERNAL) (As per Annex-1, Section 7.6, Volume IV of contract specification)	<input type="checkbox"/> MATT <input type="checkbox"/> GLOSSY <input type="checkbox"/> SEMI GLOSSY
	CLASS OF PROTECTION	<input checked="" type="checkbox"/> IP-55 (FOR INDOOR SERVICE) <input checked="" type="checkbox"/> IP-67 (FOR OUTDOOR SERVICE) <input type="checkbox"/> ANY OTHER
	CONTROL HARDWARE	<input checked="" type="checkbox"/> RELAY BASED
	FOUNDATION ARRANGEMENT	<input type="checkbox"/> FOUNDATION BOLTS <input type="checkbox"/> ANCHOR FASTENERS
	WEIGHT OF PANEL (Kg.)(Vendor to specify)



DATA SHEET FOR LOCAL PANELS

SPECIFICATION NO.: PE-SS-999-145-054A

VOLUME

SECTION

REV. NO. 02

DATE: 16.09.2013

SHEET 2 OF 3

TAG No. Qty.....

Data Sheet No.: **PES-145A-DS1-0**

Data Sheet A & B

DATA SHEET-A FOR LOCAL PANEL
(TO BE FILLED BY PURCHASER)

DATA SHEET-B
(TO BE FILLED-UP BY
BIDDER)

	PANEL TYPE	<input type="checkbox"/> PRESSURISED <input type="checkbox"/> UNPRESSURISED As per Requirement	
	CABLE GLAND	<input checked="" type="checkbox"/> DOUBLE COMPRESSION	
	AMMETER (TYPE OF INPUT) *	<input type="checkbox"/> 1 Amp CT <input type="checkbox"/> 4-20 mA	
	SCOPE OF SUPERVISION FOR ERECTION & COMMISSIONING	<input type="checkbox"/> APPLICABLE <input checked="" type="checkbox"/> NA	
* TO BE CO-ORDINATED WITH PEM ELECTRICAL			
NAME DESIGNATION SIGNATURE DATE	PREPARED BY	CHECKED BY	APPROVED BY
	AANCHAL CHOUDHARY	SACHIN SRIVASTAVA	MA MANSOORI
	SR.ENGR	DY.MNGR	D. GM
	16.09.2013	16.09.2013	16.09.2013
	COMPANY SEAL		
	NAME:		
	SIGNATURE:		
	DATE:		



DATA SHEET FOR LOCAL PANELS

SPECIFICATION NO.: PE-SS-999-145-054A

VOLUME

SECTION

REV. NO. 02

DATE: 16.09.2013

SHEET 3 OF 3

TAG No. Qty.....

Data Sheet No.: PES-145A-DS1-0

Data Sheet C

DATA SHEET-C FOR LOCAL PANEL
(TO BE FILLED BY CONTRACTOR AFTER AWARD OF CONTRACT)

GENERAL	MANUFACTURER		
	CONSTRUCTION	<input type="checkbox"/> FOLDED <input type="checkbox"/> WELDED (As per requirement EDN)	
	ENCLOSURE SHEET THICKNESS	FRONT	
		OTHER	
		DOOR	
		HEIGHT	
		OTHER	
TECHNICAL	INPUT POWER SUPPLY		
	NO. OF FEEDERS		
	CONTACT RATING OF RELAY		
	TEMP SCANNER		
	CONTROL SUPPLY		
	ALARM ANNUNCIATOR WINDOW (EXCLUDING SPARES)		
	PAINT TYPE		
	PANEL COLOUR (EXTERNAL)		
	FINISH (EXTERNAL)		
	TYPE OF MIMIC MATERIAL OF MIMC THICKNESS OF MIMIC		
	PANEL COLOUR (INTERNAL)		
	FINISH (INTERNAL)		
	CLASS OF PROTECTION		
	CONTROL HARDWARE		
	FOUNDATION ARRANGEMENT		
	WEIGHT OF PANEL (Kg.)		



DATA SHEET FOR LOCAL PANELS

SPECIFICATION NO.: PE-SS-999-145-054A

VOLUME

SECTION

REV. NO. 02

DATE: 16.09.2013

SHEET 3 OF 3

TAG No. Qty.....

Data Sheet No.: **PES-145A-DS1-0**

Data Sheet C

DATA SHEET-C FOR LOCAL PANEL
(TO BE FILLED BY CONTRACTOR AFTER AWARD OF CONTRACT)

	PANEL TYPE		
	CABLE GLAND		
	AMMETER (TYPE OF INPUT)		
	SCOPE OF SUPERVISION		
NAME SIGNATURE DATE	PREPARED BY	CHECKED BY	APPROVED BY
	AANCHAL CHOUDHARY	SACHIN SRIVASTYAVA	MA MANSOORI
	16.09.2013	16.09.2013	16.09.2013
	COMPANY SEAL NAME: SIGNATURE: DATE:		



Technical specification for
CONTROL & INSTRUMENTATION

1X800 MW KOTHAGUDEM

SPEC NO.: **PE-TS-410-145-I**

VOLUME

SECTION

REV. NO. 00

DATE : 27.05.2015

SHEET OF

ERECTION HARDWARE

1.00.00 GENERAL TECHNICAL REQUIREMENTS

This section provides the general technical guidelines for the erection materials for instruments. All erection materials shall be of good quality and conform to the operating environment of the corresponding instrument.

However, any item required for erection of Bidder supplied system but not categorically indicated in this section, shall be supplied by the Bidder and all these items shall conform to International / National standards / codes.

1.01.00 Electrical Accessories

Electrical conduit and associated materials shall conform to the requirements of the articles which follow :

- a) Rigid Steel Conduit
 - i) Conduits up to and including 25 mm shall be of 16 SWG and conduits above 25 mm shall be of 14 SWG. Minimum size of conduits shall be 19 mm.
 - ii) Each piece of conduit shall be straight, free from blister and other defects and covered with capped bushing at both ends.
 - iii) All rigid conduit couplings and elbows shall be hot dip galvanized rigid mild steel in accordance with IS:9537 Part-I (1980) and Part-II(1981).. The conduit interior and exterior surfaces shall have a continuous zinc coating with an over coat of transparent enamel lacker or zinc chromate. Conduits shall be furnished in standard length of 3 meters, threaded at both ends.
 - iv) All rigid conduit fittings shall conform to requirements of IS:2667,1976. Galvanised steel fittings shall be used with steel conduit. All flexible conduit fittings shall be liquid tight, galvanized steel. The end fitting shall be compatible with the flexible conduit supplied.
- b) Flexible Conduit
 - i) Flexible conduit shall be of three layer construction of very high quality of lead coated steel. Outside and inside layer shall be reinforced with heat resistant material.
 - ii) Lead coating outside and inside of the conduit steel surface shall provide a non-corrosive characteristic particularly in acidic atmosphere. Besides flexibility, this shall be strong enough to stay at the desired profile without support and shall be durable and strong so as to offer sufficient mechanical protection. It shall also be fully liquid dust and air tight and shall withstand a continuous hydraulic pressure up to 2 Kg/Sq. cm and temperature up to 200 °C.
- c) Special Fittings
 - i) Conduit sealing and fittings shall be provided as required and shall be consistent with the area and equipment with which they are installed.
 - ii) Double locknuts shall be provided on all conduit terminations not provided with threaded lugs and couplings. Locknuts shall be designed to securely bond the conduit to the enclosure when tightened. Locknuts shall not loosen due to vibration.

- 1.02.00 Electrical Junction Box:
Please refer to Section VII , Subsection – D of this volume of the Specification.
- 1.03.00 Cable Gland
1. Type : Double compression
 2. Entry Thread : NPT / ET
 3. Material : Brass
 4. Finish : Cadmium Plated.
 5. Protection : IP 54 or better
 6. Accessories : Neoprene gasket, locknuts, reducers etc
- 1.04.00 Cable Tray
1. Material : Mild steel, slotted
 2. Thickness : not less than 2.0 mm
 3. Finish : Hot dip galvanized
 4. Perforation : As per MFR standard
 5. Cover : Suitable for tray
- 1.05.00 Process Hook Up Accessories & specification
Material and rating of the hook up items shall suit the piping and fluid condition. Hook up materials shall be IBR certified for applicable cases. Bidder shall furnish hook up drawings and the drawings for open racks & closed racks for owner's approval.
- 1.05.01 Seamless Stainless Steel Pipe
1. Reference : ASTM A-312 TP 316
 2. Material Grade : TP 316
 3. Type : Seamless /Plain end
 4. Size : As applicable (e.g. ½" NB etc)
 5. Schedule : 40
 6. Standard Length : 5 meter
- 1.05.02 Stainless Steel Pipe Fittings

1. Reference : ASTM A-182 F 316 / ANSI B16.11
2. Type : Forged
3. Rating : 3000 lbs / 6000 lbs / 9000 lbs
4. Size : To suit related SS pipe.
5. End connection : Generally socket weld
6. Type of Fittings : Reducing coupling, male-female reducer, straight coupling, equal tee, three piece union, elbow, cap etc.

1.05.03 Seamless Stainless Steel Tube

1. Reference : ASTM A-213 , ASTM A-249 or ASTM A-269
2. Material Grade : TP 316
3. Size : As applicable (e.g. 1/2" OD X 0.083" wall thickness / 1/4" OD X 0.049" wall thickness etc.)
4. Type : Cold drawn annealed, pickled, passivated, de-scaled, hydraulically cleaned seamless tube.
5. Properties : The tube shall be free from scratches and suitable for bending and capable of being flared by hardened and tapered steel pin. The expanded tube shall show no crack or rupture. Hardness shall be RB 80.
6. Test Pressure : 400 Kg/Sq. cm (minimum)
7. Tolerance : ± 0.13 mm for outside diameter
: ± 15 % for wall thickness
8. Standard Length : 5 meter
9. Test : Flare, Hardness, Ball and Bubble Test

1.05.04 Stainless Steel Tube Fittings

1. Reference : ASTM-A-182
2. Type : Double ferrule double compression
3. Material : 316 Stainless steel forged
4. Ferrule : 316 Stainless Steel

5. Type of Fittings : Male / female connector, elbow, cross /equal tee, straight connector, bulkhead union, ferrule etc. as required to suit installation.
6. Size : To suit SS tubing and NPT end connection
- 1.05.05 C.S. Pipe
1. Reference : ASTM-A 106 Gr. C
2. Material : Cold drawn seamless black C.S.
3. Type : Seamless / Plain ends
4. Size : As applicable (e.g. 1/2" NB etc)
5. Schedule : 80, 160, XXS as required
6. Standard Length : 5 meter
- 1.05.06 C.S. Pipe Fittings
1. Reference : ASTM-A 105 / ANSI B16.11
2. Type : Forged
3. Rating : 3000 lbs / 6000 lbs / 9000 lbs
4. Size : Suitable to related C.S.Pipe
5. End connection : Generally socket weld
6. Type of Fittings : Reducing coupling, male-female reducer, straight coupling, equal tee, three piece union, elbow, cap etc.
- 1.05.07 A.S. Pipe
1. Reference : ASTM-A 335 P22 AS PER ANSI B 36.10
2. Material : Cold drawn seamless A.S.
3. Type : Seamless / Plain ends
4. Size : As applicable (e.g. 1/2" NB etc)
5. Schedule : XXS
6. Standard Length : 5 meter
- 1.05.08 A.S. Pipe Fittings

1. Reference : ASTM-A 182 F22 AS PER ANSI B 16.11
2. Type : Forged
3. Rating : 9000 lbs
4. Size : Suitable to related A.S.Pipe
5. End connection : Generally socket weld
6. Type of Fittings : Reducing coupling, male-female reducer, straight coupling, equal tee, three piece union, elbow, cap etc.

1.05.09 G.I.Pipe

1. Reference : IS-1239, Part-I
2. Type : Medium grade, threaded at both ends protected with end caps
3. Material : Continuous ERW galvanized MS pipe
4. General : Pipe shall be galvanized both inside and outside
5. Size : As applicable (e.g 1/2"/3/4"/1" etc.)

1.05.10 G.I.Pipe Fittings

1. Reference : IS-1239, Part-II for material, dimension, thread etc.
2. Style : Threaded
3. Type of Fittings : Equal tee, three piece union, unequal tee, straight socket, 90 Deg. elbow, reducing socket cap. etc. to suit installation.
4. Size : Suitable to related G.I.Pipe

1.05.11 Carbon Steel Globe Valve

1. Reference : ASTM A-105
2. Type : Globe
3. Construction : Forged Body Cadmium Plated
4. End Connection : As applicable (eg. 1/2" Socket Weld etc.)
5. Rating : Cl. 800 / CL. 2500

6. Material : Body - Carbon steel
: Stem - Hardened Steel
: Plug - AISI 316 SS
: Seat- Stainless steel stellited
7. Packing : Teflon / Grafoil as required
8. Yoke : ASTM A105
9. Hand wheel : Carbon steel
10. Design standard : As per ANSI B 16.34

1.05.12 Stainless Steel Globe Valve

1. Reference : ASTM A-182 F316
2. Type : Globe
3. Construction : Forged Body
4. End Connection : As applicable (eg. ½" Socket Weld etc.)
5. Proof Pressure : 400 Kg/Cm2
6. Material : Body - Stainless steel
: Stem - Hardened Steel
: Plug - AISI 316 SS
: Seat- Stainless steel stellited
7. Packing : Teflon as required
8. Yoke : ASTM A182 F316
9. Handwheel : Carbon steel
10. Design standard : As per ANSI B 16.34

1.05.13 Alloy Steel Globe Valve

1. Reference : ASTM A-182 F22
2. Type : Globe
3. Construction : Forged Body

4. End Connection : As applicable (eg. ½” Socket Weld etc.)
5. Rating : CL. 2500
6. Material : Body - Alloy steel
: Stem - Hardened Steel
: Plug - AISI 316 SS
: Seat- Stainless steel stellited
7. Packing : Grafoil as required
8. Yoke : ASTM A182 F22
9. Handwheel : Carbon steel
10. Design standard : As per ANSI B 16.34

1.05.14 Structural Steel

Steel supports for JB's, trays; tubes and related equipments shall not be limited to the following:

- a) MS Angle
- b) MS Channel
- c) I-Beam
- d) Hexagonal head Bolt & Nut with washer
- e) Foundation Bolt & Nut
- f) Expansion Bolt
- g) Steel Plates / Flats
- h) CRCA sheet
- i) 50 NB Pipe
- j) Pipe clamps, U Bolts & Nuts
- k) Checker plate

1.05.15 Condensate Pot

1. Reference : ASTM A182 F22 /ASTM A105
2. Material : Alloy steel / carbon steel as per application
3. Construction : Drilled from barstock
4. End connection : As applicable (e.g 3 nos. ½” socket weld end etc.)

5. Accessories : Vent valves
- 1.05.16 Instrument Valve Manifold
1. Type : Two valve manifold
: Five valve manifold
2. Mounting : Remote 2" Pipe Mounting / Transmitter Rack mounting
3. Construction : Single block (bar stock)
4. Material : Forged body and bonnet AISI 316 stainless steel
5. Ports : Mfg std. (e.g 1/2 " NPT (F) etc.)
6. Rating : 420 Kg/Sq. cm at ambient
7. Operating Temperature : (-)30 to (+)170 Deg C
8. Packing : PTFE Wafer
9. Seat & Stem : AISI 316 SS
10. Plug : AISI 316 SS free to turn on stem / 17-4 PH
11. Handle Bar : AISI 316 SS
12. Connection : Straight
13. Accessories : Plugs for all ports, Mounting Bracket , bolts , nuts
- 1.06.00 Pneumatic Hook Up Accessories
- 1.07.00 Air Header

Technical Particulars	For Panel	For Field
Material of Construction	: Stainless steel	: Stainless steel
Inlet Connection	: 2" NPT (M)	: 1" NPT (M)
Header Take-off Material	: Stainless steel	: Stainless steel
Take off connection	: 1 / 2" NPT (M)	: 1/ 2" NPT (M)
Take-off Valves Material	: stainless steel	: stainless steel

Tube Take-off	: Tube adapter on valve	: Tube adapter on valve
Drain	: SS drain valve at lowest point	: SS drain valves at lowest point



Technical specification for
CONTROL & INSTRUMENTATION

1X800 MW KOTHAGUDEM

SPEC NO.: **PE-TS-410-145-I**

VOLUME

SECTION

REV. NO. 00

DATE : 27.05.2015

SHEET OF

APPLICABLE CODES & STANDARDS

- 4.45.00 Local Instruments , Flow Elements and Control Valves
- Required local instruments including gauge boards, etc. and Flow Elements , Control valves shall be provided for safe and efficient operation of the plant. .
- 4.46.00 Erection Hardware
- Standard and good engineering practice of international standard shall be adopted throughout. All materials supplied shall be suitable for tropical, dust laden, humid power plant environment and shall be from reputed manufacture.
- 4.47.00 C&I Cabling
- Instrumentation cables shall be copper, overall screened for binary signals and individual pair and overall screened for analog signals. All cables shall be FRLS type (inner and outer sheath) ,armored, other than short run cables which may be unarmored. Unarmored cables shall run through conduits.
- C&I cable type shall also include FO , Prefab , Coaxial , compensating cable , special cable etc
- The screen shall be grounded at the remote panel end at control / equipment room only.

5.00.00 CODES AND STANDARDS

The design, manufacture, inspection, testing, site calibration and installation of all C&I equipment and systems covered under this specification shall conform to the latest editions of applicable codes and standards eg. ANSI, ASME, IEEE, ISO, IEC, IGCI, AWS, NFPA, AISC, IGS, SAMA, UBC, UL, NESC, NEMA, ISA, DIN, VDE , IS etc. Generally, the following latest edition of codes and standards prevailing at the time of award of contract shall be applicable.

- 1) Temperature Measurement
 - a) Instrument and apparatus for temperature measurement - ASME PTC 19.3 (1974).
 - b) Temperature Measurement - Thermocouples - ANSI - MC 96.1 - 1982.
 - c) Temperature Measurement by electrical resistance thermometers - IS: 2806
 - d) Thermometer-element-Platinum resistance - IS: 2848 / DIN 43760.
- 2) Pressure Measurement
 - a) Instrument and apparatus for pressure measurement - ASME PTC 19.2 (1964).
 - b) Bourdon tube pressure and vacuum gauges - IS: 3624/1996.

- 3) Flow Measurement
 - a) Instruments and apparatus for flow measurement - ASME PTC 19.5 (1972) Interim supplement, Part-II
 - b) Measurements of fluid flow in closed conduit - BS 1042.
- 4) Electronic Measuring Instruments and Control Hardware
 - a) Automatic null balancing electrical measuring instruments -ANSI C 39.4 (Rev. 1973), IS 9319
 - b) Safety requirements for electrical and electronic measuring and controlling instrumentation - ANSI C 39.5 / 1974.
 - c) Compatibility of analog signals for electronic industrial process instruments - ISA-S 50.1: ANSI MC 12.1 / 1975.
 - d) Dynamic response testing of process control instrumentation - ANSI MC 4.1 (1975) - ISA -S26 (1968).
 - e) Surge withstand capability (SWC) tests - ANSI C 37.90A (1989), IEC-255.4.
 - f) Printed circuit boards - IPC TM-650, IEC 326C.
 - g) General requirements and tests for printed wiring boards - IS-7405 (Part-I)/1973.
 - h) Edge socket connectors - IEC 130-11.
 - i) Requirements and methods of testing of wire wrap terminations--DIN 41611 Part-2.
 - j) Dimensions of attachment plugs and receptacles- ANSI C73-1973.(Supplement ANSI C73a – 1980)
 - k) Direct Acting Electrical Indicating Instruments - IS - 1248 - 1968
- 5) Instrument Switches and Contacts
 - a) Contact Rating - AC services NEMA ICS Part-2 125, A-600
 - b) Contact Rating - DC services NEMA ICS Part-2 125, N-600
- 6) Enclosures
 - a) Enclosures for Industrial Controls and Systems--NEMA ICS-6-110.15 through 110.22
 - b) Racks, panels and associated equipment -EIA: RS-310-B-1983 (ANSI C83.9 - 1972) / IEC 60947 / IEC 60529
 - c) Protection Class for Enclosures , Cabinets Control Panels and Desks - IS 2147 1962

- 7) Apparatus, Enclosures and Installation Practices in Hazardous Area
 - a) Classification of hazardous area - NEMA Article 500, Volume-6, 1978./ NFPA Article 500 , Vol.70-1984
 - b) Electrical Instruments in hazardous dust locations - ISA-RP 12.11.
 - c) Intrinsically safe apparatus - NFPA Article 493 Volume-4 1978.
 - d) Purged and pressurized enclosure for electrical equipment in hazardous location - NFPA Article 496 Volume-4, 1982.

- 8) Sampling System
 - a) Stainless Steel material of tubing and valves, for sampling system - ASTM A 269-79 GRTO-316.
 - b) Submerged helical coil heat exchangers for sample coolers -- ASTM D11-98.
 - c) Steam and water sampling ,conditioning and analysis in the power cycle - ASME PTC - 19.11
 - d) Standard methods of sampling system - ASTM D 1066-69

- 9) Annunciators
 - a) Specifications and guides for the use of general-purpose annunciators - ISA RP 18.1.
 - b) Surge withstand capability tests -ANSI C37.90 a -1971 and IEEE Standard 472-1974.

- 10) Interlocks, Protections
 - a) Relays and relay system associated with electric power apparatus - IEEE Standards 3.13.
 - b) Surge withstand capability tests - ANSI C37.90 a - 1971 and IEEE Standard 472-1974.
 - c) General requirements and tests for switching devices for control and auxiliary circuits including contactor relays - IS-6875 (Part-I)/1973.
 - d) Turbine water damage prevention - ASME-TDP-1-1980.
 - e) Boiler safety interlocks - NFPA Section 85B, 85D, 85E, 85F, 85G.
 - f) Installation and operation of Pulverized fuel system - ANSI / NFPA 8503
 - g) Functional diagramming of Instrument and control systems - SAMA PMS 22.1
 - h) Digital interface for programmable instrumentation - ANSI / IEEE 488

11) Control Valves

- a) Control valve sizing (Incompressible fluids) - ISA-S39.2 / 1972.
- b) Control valve sizing (Compressible fluids) - ISA-S39.4 / 1972.
- c) Control Valve seat leakage – ANSI / FCI 70.2
- d) Face to face dimensions of Control Valves - ANSI B16.10
- e) Control Valve Capacity Test Procedure – ISA – S75.02

12) Process connection Piping and Tubing

- a) Seamless Carbon Steel Pipe - ASTM-A-106.
- b) Forged carbon steel fittings - ASTM-A-105.
- c) Dimensions of fittings - ANSI-B16.11.
- d) Code for pressure piping, welding, hydrostatic testing - ANSI-B 31.1.
- e) Nomenclature for instrument tube fittings - ISA-RP 42.1 / 1982.
- f) Seamless Stainless Steel Tube ASTM A-213 TP 316 / ASTM A-269 TP 316
- g) Seamless Alloy Steel Pipe ASTM A 335 P22
- h) Seamless Stainless Steel Pipe ASTM A-312 TP 316
- i) Forged and Rolled alloy steel pipe flanges , forged fittings , valves and parts ASTM A - 182
- j) Pipe fittings of wrought carbon steel and ally steel - ASTM A - 234
- k) Composition bronze metal castings ASTM B - 62
- l) Seamless copper tube , bright annealed ASTM B- 168
- m) Valves flanged and butt welding ends ANSI B 16.34

13) Cables

- a) Thermocouple extension wires / cables - ANSI MC96.1.
- b) Insulated Wire and Cable for the Transmission and Distribution of Electrical Energy-IPCEA S-61-402
- c) Guide for design and installation of cable system in power generating station (insulation, jacket materials) -IEEE Standard 422.
- d) Requirements of vertical tray flame test - IEEE 383
- e) Standard specification for tinned soft or annealed copper wire for electrical purpose - ASTM B33.



Technical specification for
CONTROL & INSTRUMENTATION

1X800 MW KOTHAGUDEM

SPEC NO.: **PE-TS-410-145-I**

VOLUME

SECTION

REV. NO. 00

DATE : 27.05.2015

SHEET OF

CABLE BOQ

CABLE SIZES FOR 1X800 MW KOTHAGUDEM TPS	
Sl no.	Cable Type
	G-TYPE
1	2P X 0.5 sqmm
2	4P X 0.5 sq mm
3	8P X 0.5 sqmm
4	12P X 0.5 sqmm
5	2P X 1.5 sqmm
	F-TYPE
1	4P X 0.5 sqmm
2	8P X 0.5 sqmm
3	12P X 0.5 sqmm
4	20P X 0.5 sqmm
	CONTROL CABLE
1	3C X 2.5 sqmm
2	5C x 2.5 sq mm
3	12C x 2.5 sqmm



Technical specification for
CONTROL & INSTRUMENTATION

1X800 MW KOTHAGUDEM

SPEC NO.: **PE-TS-410-145-I**

VOLUME

SECTION

REV. NO. 00

DATE : 27.05.2015

SHEET OF

KKS PHILOSOPHY



DOCUMENT TITLE

KKS NUMBERING PHILOSOPHY

1 X 800 MW KOTHAGUDEM TPS, TELANGANA

KKS NUMBERING PHILOSOPHY

For identifying (tagging) an instrument / equipment in Power plant KKS numbering scheme is used. The purpose is to assign a unique number to every equipment in the power plant. For C&I equipment unique number are to be provided up to the signal level so that a unique number Input / Output exist in DCS for every signal.

Normally KKS number is a 10 digit alpha-numeric code and is typically split into the following:

X	X	X	A	A	Y	Y	B	B	B
---	---	---	---	---	---	---	---	---	---

First three digits indicate the Sub-System. The Code for the major system are given as per **Annexure-1**.

Fourth and Fifth digits are the **Numerical Keys at System Code Level** and used to distinguish between main systems having same Alpha Codes.

Sixth and Seventh digits are the **Equipment / Apparatus / Measuring Circuit Code**. The code of various Equipment / Apparatus / Measuring Circuit is shown in **Annexure-2**

Eight, Nine and tenth digits are the **Numerical Keys at Equipment / Apparatus / Measuring Circuit Code** and used to distinguish between various instruments in the same sub-group. Numerical keys at System / Equipment / Apparatus / Measuring Circuit is shown in **Annexure-3**.

**ANNEXURE-1****List of System / Sub-System Codes used in Power Plant:**

- 1) Self-cleaning strainer and Debris filter : PCA

ANNEXURE-2**Standard Equipment Codes:**

AA	Valves including drives, also hand operated
AB	Seclusions, Lock, Gates, Doors
AC	Heat Exchanger
AE	Turning, Driving, Lifting equipment
AF	Continuous conveyors, Feeders
AG	Generator Units
AH	Heating and Cooling Units
AK	Pressing and Packaging equipment
AM	Mixer, Stirrer
AN	Blower, Air Pumps / Fans, Compressor Units
AP	Pump Units
AT	Purification, Drying, Filter
AV	Combustion Equipment e.g. grates

Standard Apparatus Codes:

BB	Vessels and Tank
BF	Foundation
BG	Boiler Heating Surfaces
BN	Injector, Ejector
BP	Flow and throughput limitation equipment (Orifice)
BQ	Holders, Carrying Equipment, Support
BR	Piping, Ducts, Chutes, Compensator
BS	Sound Absorber
BU	Insulations, Sheatings

Standard Measuring Circuits Codes:

CD	Density
CE	Electrical Quantities
CF	Flow, throughput
CG	Distance, Length, Position
CK	Time
CL	Level
CM	Humidity
CQ	Analysis (SWAS)



CS	Speed, Velocity, Frequency
CT	Temperature
CY	Vibration, Expansion

ANNEXURE-3

Numerical Keys

A) Numerical Keys at System Code Level

- i) Use 10, 20, 30... To distinguish between main systems having same Alpha Codes. Examples:
 - a) Main Steam (Left) and Main Steam (Right)
 - b) BFP – A/B/C
 - c) ID Fan – A/B, FD Fan A/B, AH – A/B
- ii) For branch off from main system path having code say 10, keep the same alpha code and use 11, 12, 13 etc. Similarly for other branch off from main system path having code say 20, keep the same alpha code and use 21, 22, 23 etc and shall carry on further in the same way.
- iii) If the branch off from main system / sub system path is used for some other system, where different alpha codes can be applied, then in that case the said branch line will be designated by the alpha codes of the system to which it is providing the input.

B) Numerical keys at Equipment Code level:

There are three numerical keys available for each type of equipment code. Following has been agreed upon considering present practice, better flexibility and ease in sorting.

i) Valves and Dampers --- Equipment Code – AA

		<u>N1</u>	<u>N2 N3</u>
Motorised (<i>on/off duty</i>)	-	0	01 to 50
Motorised (<i>inching duty</i>)	-	0	51 to 99
Pneumatic (Control)	-	1	01 to 50
Motorised (<i>thyrestor Control</i>)	-	1	51 to 99
Sol. Operated (Open / Close duty (Valves, NRVs, Gate)	-	2	01 to 99
Hydraulic	-	3	01 to 99
NRV (Without actuation)	-	4	01 to 99



DOCUMENT TITLE

KKS NUMBERING PHILOSOPHY

1 X 800 MW KOTHAGUDEM TPS, TELANGANA

Manual	-	5	01 to 99
Manual	-	6	01 to 99
Relief & Safety Valves	-	7	01 to 99
Reserve	-	8	01 to 99
Reserve	-	9	01 to 99

ii) **Field Instruments**

Field Transmitters & Analog Signals	-	0	01 to 99
Field Switches & Binary Signals	-	1	00 to 99
PG Test Point	-	4	00 to 99
Gauges	-	5	00 to 99
Automatic Turbine Tester (ATT)-HWR	-	2	00 to 99

(Reserved for protection Signals used by Hardwar)

Example of Numerical Key Usage:

In line with the philosophy adopted for Valves / Dampers /instruments etc. pumps and fans in the main systems (having different system code) can be numbered as AP/N100 and as AP/N101, 102, Where system code is same.



**TITLE : TECHNICAL SPECIFICATION
FOR
DEBRIS FILTER (DF)**

SPEC. NO. PE-TS- 410-165-N001

VOLUME : IIB

SECTION : D

REV. NO. 0

**DATE :
18.06.2015**

SHEET 1 of 1

SECTION – D

STANDARD TECHNICAL SPECIFICATION

SECTION D1 : DEBRIS FILTER

SECTION D2 : ELECTRICAL SYSTEMS

SECTION D3 : C&I SYSTEM



**TITLE : TECHNICAL SPECIFICATION
FOR
DEBRIS FILTER (DF)**

SPEC. NO. PE-TS- 410-165-N001

VOLUME : IIB

SECTION : D

REV. NO. 0

**DATE :
18.06.2015**

SHEET 1 of 1

SECTION D1

**STANDARD TECHNICAL SPECIFICATION
FOR
DEBRIS FILTER**

	TITLE : STANDARD TECHNICAL SPECIFICATION DEBRIS FILTER (Backwash Type)	SPECIFICATION NO. PE-TS- 999-165-N003	
		VOLUME : II B	
		SECTION : D	
		REV. NO. 03	DATE : 29.07.2007
		SHEET 1	OF 10

1.00.00 **GENERAL**

This specification covers the Design, Performance and Operational Requirements, Constructional Features, Manufacture, Assembly. Inspection and Testing at the Manufacturer's and/or his Sub-contractor's works and Painting for delivery of Debris Filter (Backwash Type) complete with all accessories as specified hereinafter.

2.00.00 **CODES AND STANDARDS**

2.01.00 The design, materials manufacture, inspection and testing of the Debris Filter complete with all accessories, shall comply with the requirements of the latest revisions of the following appropriate codes and standards :

2.01.01 IS / BS / DIN / US Standards regarding pressure vessels, pipes, flanges and others as necessary.

2.01.02 IS / BS / DIN / ASTM Standards for materials specification and testing procedures.

2.01.03 IS / BS / DIN / AWWA Standards for valves and their testing.

2.02.00 In case of any conflict between the above codes / standards and this specification, the later shall prevail and in case of any further conflict in the matter, the interpretation of the specification by the Engineer shall be final and binding.

3.00.00 **DESIGN AND CONSTRUCTION**

3.01.00 **General Requirements**

3.01.01 Unless otherwise necessary manufacturer's standard and proven models of the Debris Filter shall be supplied.

3.01.02 The Debris Filter shall be capable of safe, proper and continuous operation. Vibration, noise, mechanical stresses shall be kept within allowable limits specified by relevant codes / standards, In design due attention shall be given to ease of maintenance, repair and cleaning.

3.01.03 Suitable corrosion allowance shall be provided wherever necessary.

3.01.04 The Debris Filter shall be designed to suit installation in on-line or off-line arrangement as specified in Data Sheet-A.

In the on-line arrangement, the inlet and outlet pipes of the debris filter shall be in line with each other on the same axis without any off-set between the centre lines of inlet and outlet pipes.

In the off-line arrangement, the debris filter inlet and outlet pipes shall be at right angle (90°) to each other.

	TITLE : STANDARD TECHNICAL SPECIFICATION DEBRIS FILTER (Backwash Type)	SPECIFICATION NO. PE-TS- 999-165-N003	
		VOLUME : II B	
		SECTION : D	
		REV. NO. 03	DATE : 29.07.2007
		SHEET 2	OF 10

3.02.00 Performance Requirements

The Debris Filter with all accessories shall be designed and guaranteed to meet the following requirements :-

3.02.01 The Debris Filter shall perform satisfactorily under the flow and pressure conditions specified in Data Sheet -A and shall be capable of housing the various forms of debris / sludge i.e., suspended particles / matter, mussels, grass, leaves, wood pieces etc. The performance of the Debris Filter shall be continuous with minimum number of flushing / backwashing operations.

3.02.02 The Debris Filter shall be designed such that the pressure drop across the Debris Filter (i.e., between inlet and outlet connections) under clean conditions and partially (50%) choked conditions shall not be more than those specified in Data Sheet -A.

3.02.03 Unless otherwise specified in Data Sheet -A, debris discharge / wash water flow rate during flushing/back washing operation shall be limited to 10% of the total flow rate and flushing / backwashing operation shall be completed within a period of maximum three (3) minutes. The pressure drop across the debris filter during flushing/backwashing operation shall not be more than the pressure drop under partially (50%) choked condition.

3.02.04 The coarse particles and floating matter accumulating at the filter section/screen are flushed out of the system by the system by the debris flushing / backwash unit such that the pressure drop across the filter after flushing / backwashing, shall not be more than 1.1 times the pressure drop under clean conditions.

3.03.00 Operational Requirement

The Debris Filter and other accessories shall be designed for the following flushing/backwashing operation modes :

3.03.01 Complete automatic flushing/backwashing operation effected by the following :-

- ◆ differential pressure measuring system at a pre-determined differential pressure across the filter screen.
- ◆ adjustable timer (0-24 hours)
- ◆ push button (for manual initiation of sequential flushing / backwashing)

3.03.02 Manual operation in the event of failure of control system.

3.04.00 Filter Housing / Body

3.04.01 The Debris Filter housing/body shall be designed and manufactured as per the applicable codes for pressure vessels. It shall house the filter section / screen assembly and shall have flanged inlet, outlet, flushing / debris discharge openings and pressure measuring tappings etc.

	TITLE : STANDARD TECHNICAL SPECIFICATION DEBRIS FILTER (Backwash Type)	SPECIFICATION NO. PE-TS- 999-165-N003	
		VOLUME : II B	
		SECTION : D	
		REV. NO. 03	DATE : 29.07.2007
		SHEET 3	OF 10
3.04.02	In design of Debris Filter housing / body due attention shall be given for easy removal and replacement of filter section / screen assembly.		
3.04.03	The Debris Filter shall be provided with inspection hole with bolted cover.		
3.04.04	The Debris Filter body / housing shall be provided with vent and drain connections with isolating valves. It shall be possible to drain unfiltered and filtered water.		
3.04.05	If specified in Data Sheet-A, filter body/housing shall be epoxy painted.		
3.05.00	<u>Filter Section / Screen assembly.</u>		
3.05.01	The Debris Filter section/screen shall be designed for the maximum differential pressure across the filter and shall be securely positioned by a supporting cage and shall be securely mounted in the housing or body.		
3.05.02	The perforation/mesh size of the Debris Filter section shall not be more than that specified in Data Sheet-A.		
3.05.03	The arrangement of the Debris Filter section shall be such that the forced accumulation of debris on the filter screen / section shall be minimum.		
3.06.00	<u>Differential Pressure Measuring System</u>		
3.06.01	The Debris Filter shall be provided with a measuring system for differential pressure across the filter section/screen, to check debris accumulation and to initiate flushing / backwashing operation. This shall consist of a differential pressure switch / transmitter for automatic flushing operation, a differential pressure gauge for manual observation with adequate number of tapping with isolating valves and equalising valves.		
3.06.02	The contacts for differential pressure switch / transmitter and for differential pressure gauge shall be independent so that in the event of failure of one, the other is available .		
3.06.03	The differential pressure measuring system shall be provided with D.P. transmitter ,DPS & DPG of remote seal arrangement..		
3.07.00	<u>Flushing / Backwash Unit. :</u>		
3.07.01	The Debris Filter shall be provided with suitable flushing/backwash unit (to be installed at ground floor) and debris discharge/backwash outlet valve with associated actuator to flush out the accumulated debris / sludge.		
3.07.02	The flushing pump shall be provided with mechanical seals to the extent possible. If gland packing is provided it should be of good quality to prevent leakage of water from pump glands.		

	TITLE : STANDARD TECHNICAL SPECIFICATION DEBRIS FILTER (Backwash Type)	SPECIFICATION NO. PE-TS- 999-165-N003		
		VOLUME : II B		
		SECTION : D		
		REV. NO. 03	DATE : 29.07.2007	
		SHEET 4 OF 10		
3.07.03	The flushing arrangement shall be either fixed type with flushing valves or a rotating debris extractor.			
3.07.04	If any water is to be injected for backwashing the filter section/screen, water shall be taken from down-stream side of the filter section/ screen. Necessary pump, valves and piping for water injection shall be supplied.			
3.07.05	View glass to be provided in debris outlet pipe to monitor the flushing of debris.			
3.08.00	<u>Valves</u>			
	The flushing valves (if any,) the debris discharge/backwash outlet valve, isolation, vent and drain valves shall conform to appropriate codes / standards. The debris discharge/backwash outlet valve shall be larger than the debris discharge/back wash outlet pipe.			
3.09.00	<u>Instrumentation and Control System</u>			
3.09.01	Complete instrumentation and control system for automatic flushing / backwashing operation, protection, interlocking, indication/annunciation of high differential pressure and other malfunctions etc. shall be provided. This shall consist of adequate operational hardware, local control panel and interconnecting control and power cabling between the control panel and the self-cleaning filter and its associated electrical devices.			
3.09.02	The control panel shall house all necessary instruments, indicating/ annunciation lamps, alarms, differential pressure indicator, timer, function selector switches, relays, protection and interlocking systems, start/stop push buttons, counter to register number of flushing operations etc., and shall be complete with internal wiring. In addition to the above, the control panel shall meet the requirements of the enclosed specification.			
3.09.03	All instrumentation shall be of reputed make and shall meet the requirement of the enclosed specification.			
3.10.00	<u>Actuators :</u>			
	The actuators for flushing arrangement and debris discharge valve shall be electric motor operated and shall meet the requirements of the enclosed specification. The actuators shall be provided with auxiliary handwheel for manual operation in the event of power failure.			
3.11.00	<u>Electric Motors :</u>			
	The drive motors for differential pressure measuring system flushing pump and water injected pump (if applicable) shall confirm to the requirements of the enclosed specification.			

	TITLE : STANDARD TECHNICAL SPECIFICATION DEBRIS FILTER (Backwash Type)	SPECIFICATION NO. PE-TS- 999-165-N003	
		VOLUME : II B	
		SECTION : D	
		REV. NO. 03	DATE : 29.07.2007
		SHEET 5	OF 10
3.12.00	<u>Other Accessories.</u>		
3.12.01	Counter flanges, flat faced slip on type, complete with gaskets, bolts and nuts etc., shall be supplied for the filter inlet, outlet connections and all other terminal points. Fabrication, dimensions and drilling of the flanges shall conform to the codes/standards specified in Data Sheet-A.		
3.12.02	Debris Filter shall be provided with suitable lifting arrangement for handling during erection and maintenance.		
3.12.03	Necessary supporting arrangement (wherever applicable) complete with foundation plates, bolts, nuts etc., shall be provided.		
3.13.00	<u>Material of Construction</u>		
	Material of Debris Filter and other accessories shall be corrosion resistant and consistent with the fluid handled. However material specification for various components shall be equal or superior to those specified in Data Sheet-A.		
4.00.00	<u>PAINTING</u>		
4.01.00	The surface preparation of the filter housing / body and other parts shall be done as per the standard mentioned in Data Sheet-A and shall include the following :		
	a) Removal of oil, grease, dirt and swarf etc. b) Removal of rust and scale etc. c) Sand blasting/shot blasting.		
4.02.00	All internal surfaces of the filter which are subject to immersion or water spray and which are not made of stainless steel or other corrosion resistant materials after surface preparation, shall be coated with four coats (minimum 500 microns thick) of epoxy paint of approved make and quality over a coat of zinc chromite primer, unless otherwise specified in Data sheet-A.		
4.03.00	The external surfaces of the filter and other accessories after surface preparation, shall be coated with two coats (minimum 250 microns thick) of synthetic enamel paint of approved make and quality over two coats of red oxide primer, unless otherwise specified in Data Sheet-A.		

	TITLE : STANDARD TECHNICAL SPECIFICATION DEBRIS FILTER (Backwash Type)	SPECIFICATION NO. PE-TS- 999-165-N003	
		VOLUME : II B	
		SECTION : D	
		REV. NO. 03	DATE : 29.07.2007
		SHEET 6	OF 10

5.00.00 **SHOP INSPECTION AND TESTS**

5.01.00 **General :**

5.01.01 Manufacturer shall conduct all tests and stage inspections as per the approved quality plan to ensure that the Debris Filter and other accessories shall conform to the requirements of this specification and of the applicable codes/ standards.

5.01.02 All materials used for manufacture/fabrication of the Debris Filter shall be of tested quality. Relevant test certificates for chemical analysis, mechanical tests and heat treatment shall be made available before the final shop inspection. In case the relevant test certificates are not available, the manufacturer shall arrange to carry out the necessary tests as per approved quality plan and applicable codes at his cost, for which samples shall be identified by BHEL's representative.

5.01.03 All shop tests shall be conducted in the presence of BHEL's representative and test certificates / reports for the same shall be furnished to BHEL for approval.

5.01.04 Qualification of welding procedures and welders shall be as per ASME B&PV Code, Section-IX / applicable codes.

5.02.00 **Filter Housing / Body**

5.02.01 Chemical analysis, mechanical tests shall be carried out on housing/body material.

5.02.02 All butt welded joints shall be subjected to radiographic / ultrasonic testing as per applicable codes. However all welded joints shall be subjected to 100% magnetic particle / penetrant testing to ensure freedom from defects.

5.03.00 **Rubber Lining (as applicable)**

Rubber lining shall be subjected to surface crack test, 100% spark and hardness tests and shall be checked for layer thickness, defects etc.

5.04.00 **Filter Section/Screen assembly**

Supporting cage and filter section/screen materials shall be tested for chemical properties. Checks shall be carried out for perforation/mesh size, defects etc.

5.05.00 **Flushing / Backwash Unit**

5.05.01 Material of various components of the flushing/Backwash Unit shall be tested for chemical and mechanical properties.

5.05.02 Hollow shaft of backwash rotor shall be ultrasonically tested as per ASTM-A 388 for internal flaws. Penetrant test shall be carried out for surface flaws.

	TITLE : STANDARD TECHNICAL SPECIFICATION DEBRIS FILTER (Backwash Type)	SPECIFICATION NO. PE-TS- 999-165-N003	
		VOLUME : II B	
		SECTION : D	
		REV. NO. 03	DATE : 29.07.2007
		SHEET 7	OF 10

5.06.00 **Valves**

Inspection and testing of valves including leakage test shall be carried out as per the requirements of the applicable standards. Correlating test certificates for materials of the valve components shall be furnished.

5.07.00 **Flanges**

5.07.01 In case of fabricated flanges, all the welds shall be subjected to 100% radiography as per ASME B&PV code, section VIII, Division-1.

5.07.02 In case of forged flanges, ultrasonic testing shall be carried out as per ASTM-E 388.

5.07.03 If the thickness of the plate used for flanged is 40mm or more the same shall be checked ultrasonically as per ASTM-A 435 to demonstrate the absence of lamination and lack of fusion etc.

5.07.04 Chemical and mechanical test certificates shall be furnished for flange materials.

5.07.05 Flanges shall be checked for edge preparation, fit up and satisfactory working with matching parts.

5.08.00 All materials for various nozzles, seals, pipes, gaskets, nuts bolts etc., shall be of tested quality and correlating test certificates for chemical and mechanical properties shall be furnished.

5.09.00 **Dimensional Checks**

Dimensional checks of various components of the Debris Filter shall be carried out as per the drawings approved by BHEL.

5.10.00 **Hydrostatic Test**

Hydrostatic test shall be conducted on the Debris Filter housing/body at a pressure of 1.5 times the design pressure. The duration of the test shall be minimum 30 minutes.

5.11.00 **Leakage Test**

Leakage test shall be conducted at the design pressure to demonstrate that the filter assembly is leak tight and no water seepage shall take place at various nozzle and valve connections.

	TITLE : STANDARD TECHNICAL SPECIFICATION DEBRIS FILTER (Backwash Type)	SPECIFICATION NO. PE-TS- 999-165-N003	
		VOLUME : II B	
		SECTION : D	
		REV. NO. 03	DATE : 29.07.2007
		SHEET 8	OF 10

5.12.00 **Functional Tests**

The Debris Filter assembly complete with valves, actuators and other accessories shall be subjected to functional tests and the following shall be checked :-

5.12.01 Smooth and free operation of all movable parts.

5.12.02 Interlocks and sequential operation.

5.12.03 Satisfactory operation of actuator torque switches, limit switches etc.

5.13.0 Performance Test :

Performance Test shall be conducted to ensure that the Debris Filter meets the specified performance requirements.

6.00.00 **TESTING AT SITE**

After completion of installation at site, the Debris Filter with complete accessories, will be tested to check that the filter performance meets the requirements of its specification, Rectification of all defects shall have to be done by the supplier at no extra cost to the Owner / Purchaser. However the Owner / Purchaser reserves the right to reject the equipment / parts not meeting the requirement if the deficiency still persists.

7.00.00 **PERFORMANCE GUARANTEE & Bid evaluation criteria**

The Debris Filter shall be guaranteed to meet the performance requirements specified in Section-D , Data Sheet A and Guarantee schedule and also for trouble free operation after commissioning. Schedule of performance guarantees (enclosed in Volume III) duly filled and signed shall be furnished with the bid.

The Performance guarantees of equipments shall stand valid till the satisfactory completion of performance testing & its acceptance by BHEL/ Customer. If the guarantee period specified in the Commercial Specification is higher, same shall prevail.

7.01.00 Performance Guarantee Parameters shall be as under :

- Pressure drop in Debris Filters in clean condition viz. after backwashing.

7.02.01 Bidder to note that bids shall be evaluated on account of pressure drop across Debris Filters (in clean condition) & liquidated damages on account of not meeting the same shall be in accordance with following :

A) **Bid Evaluation Criteria and Liquidated Damages:**

The bids received shall be evaluated for Pressure drop across Debris Filter:

	TITLE : STANDARD TECHNICAL SPECIFICATION DEBRIS FILTER (Backwash Type)	SPECIFICATION NO. PE-TS- 999-165-N003	
		VOLUME : II B	
		SECTION : D	
		REV. NO. 03	DATE : 29.07.2007
		SHEET 9 OF 10	

- The permissible limit of pressure drop across Debris Filter in clean condition shall be 0.5 MWC.
- If the pressure drops quoted are higher than above limit, the bids shall be technically loaded @ Rate as mentioned in Data Sheet-A-for respective projects per 1 MWC pressure drop (viz. per unit).
- However no advantage shall be given for pressure drops quoted less than above permissible limit.

The bids will be technically rejected for pressure drops quoted higher than above maximum limit.

- The guaranteed pressure drops shall be demonstrated at site by vendors and if found higher shall be subject to LD @ twice the bid evaluation factor as above.

8.00.00 QUALITY ASSURANCE & QUALITY PLAN

8.01.00 The Debris Filter and other accessories to be supplied shall have assured quality and workmanship.

8.02.00 Typical quality plans are enclosed herewith this specification for bidder's guidance. The bidder shall comply with these minimum requirements and shall furnishing own quality plan based on materials and components of the filter being offered.

9.00.00 NAME PLATE AND TAG NUMBERS

9.01.00 The Debris Filter shall be provided with a permanently attached brass or stainless steel plate indicating the following details:-

- a) Design flow
- b) Design and test pressures
- c) Design temperature
- d) Filter section/screen mesh size
- e) Empty and operating weights
- f) Revolving speed of backwash rotor

9.02.00 Each valve shall be provided with a name plate indicating the following :-

- a) Service
- b) Design and test pressures
- c) Maximum flow and flow direction
- d) Size
- e) Engineer's Tag Number

Tag numbers will be indicated on the drawing submitted for approval during contract stage.

9.03.00 Each motor / actuator shall be provided with a name plate indicating the following details :

	TITLE : STANDARD TECHNICAL SPECIFICATION DEBRIS FILTER (Backwash Type)	SPECIFICATION NO. PE-TS- 999-165-N003	
		VOLUME : II B	
		SECTION : D	
		REV. NO. 03	DATE : 29.07.2007
		SHEET 10	OF 10

<p>a) Supply conditions. b) KW Rating c) Make</p> <p>10.00.00 <u>DRAWINGS, DATA & INFORMATION TO BE SUBMITTED WITH THE BID</u> The bidder shall furnish the following drawings, data and information alongwith the bid without which the offer will be deemed incomplete.</p> <p>10.01.00 Data sheet-B with all particulars / data duly filled in.</p> <p>10.02.00 General arrangement / installation drawings of the Debris Filter with all accessories, incorporating the principal dimensions and weights of equipment offered, size and location of various nozzle connections, supporting arrangement (if applicable) and scope of supply etc.</p> <p>10.03.00 Cross-sectional / detailed drawings of filter housing / body, filter section / screen assemblies, flushing / backwashing unit, differential pressure measuring system, actuators, motors, control panel etc., indicating bill of quantities and materials of construction.</p> <p>10.04.00 Flow and control logic diagrams for complete filter during normal and flushing / backwashing operations.</p> <p>10.05.00 Performance evaluation procedure at site.</p> <p>10.06.00 Control panel layout and list of instruments provided on control panel.</p> <p>10.07.00 List of annunciations, protections and interlocks provided.</p> <p>10.08.00 Write-up on operation, control, monitoring, interlocks and protection of filter.</p> <p>10.09.00 Manufacturer's descriptive and illustrative literature on the equipments / components being offered.</p> <p>10.10.00 A detailed experience list about the successful installations of similar equipment of equal or higher inlet / outlet sizes and flow capacities for similar application.</p> <p>10.11.00 A comprehensive write-up on the testing facilities, tests to be conducted inspection methods and QA system adopted by the manufacturer.</p> <p>10.12.00 Quality plan for the Debris Filter and for all its. accessories.</p> <p>11.00.00 <u>DRAWINGS, DATA & INFORMATION TO BE SUBMITTED AFTER THE AWARD OF CONTRACT :</u></p> <p>The drawings, data and other documents as required in Data Sheet-C shall be furnished after the award of contract.</p>



TITLE :

DATA SHEET – A FOR
DEBRIS FILTER (DF)

SPECIFICATION NO. : PE-TS-410-165-N001

VOLUME : II B

BOOK: I

REV. NO. 00 DATE -25.06.2015

Page 1 of 9

1x800MW KOTHAGUEDEM TPS UNIT-12-TSGENCO

S. No.	DESCRIPTION	UNITS	
1.0	GENERAL		
1.1	Type of Strainers/ Filters	-	Debris Filter
1.2	No. of Strainers/ Filters required	Nos.	Total Two (2) Sets.
1.3	Inlet connection (Nb)	mm	2740 x 20
1.3	Outlet connection (Nb)	mm	2740 x 20
1.4	Filter type/ duty	-	On line / continuous
1.5	Location	-	Condenser Inlet (Outdoor installation)
1.6	Liquid handled	-	Clarified Water as per Analysis Attached
2.0	DESIGN DATA		
2.1	Operating pressure	Bar (g)	2.0 to 2.6
2.2	Design pressure	Kg/cm ²	5.5 Kg/cm ² (g) & Vacuum 0.1Kg/cm ² (abs)
2.3	Design temperature	Deg. C	60
2.4	Flow rate through filter a) Normal b) Maximum		45000 CUB.M/HR 58500 CUB.M/HR
2.5	Design differential pressure for filter section/ screen	Bar (g)	1.5 (Min.)



TITLE :

**DATA SHEET – A FOR
DEBRIS FILTER (DF)**

SPECIFICATION NO. : PE-TS-410-165-N001

VOLUME : II B

BOOK: I

REV. NO. 00 DATE -25.06.2015

Page 2 of 9

S. No.	DESCRIPTION	UNITS	1x800MW KOTHAGUEDEM TPS UNIT-12-TSGENCO
2.6	Type of suspended matter likely to enter the filter	-	Typical debris encountered in closed circuit CW system with Cooling Tower
2.7	Differential pressure measuring system set pressure • For initiating flushing/ backwashing • For alarm/ annunciation	mbar	80
		mbar	160
2.8	Filter section/ screen perforation size	mm	5 mm (Max)
2.9	Free flow area in the screen basket	-	Atleast 120 % of pipe inlet area
3.0	GUARANTEED PERFORMANCE REQUIREMENT		
3.1	Pressure drop across the filter (i.e. between inlet and outlet connection) at normal flow	-	
	a) Clean condition	mbar	Refer Section – C of specification
	b) Partially (50%) choked condition	mbar	Not to exceed 80
3.2	Debris discharge flow during flushing period	Cub m/ Hr.	Not to exceed 5% of total flow rate
4.0	MATERIALS OF CONSTRUCTION		
4.1	Filter body/ housing	-	CS:IS 2062 Gr. B Epoxy painted inside (with min. housing thick. Same as connecting pipe thick.)
4.2	Filter screen/ section	-	SS-316



TITLE :

**DATA SHEET – A FOR
DEBRIS FILTER (DF)**

SPECIFICATION NO. : PE-TS-410-165-N001

VOLUME : II B

BOOK: I

REV. NO. 00 DATE -25.06.2015

Page 3 of 9

S. No.	DESCRIPTION	UNITS	1x800MW KOTHAGUDEM TPS UNIT-12-TSGENCO
4.3	Shaft	-	SS-316
4.4	Supporting cage	-	SS-316
4.5	Differential measuring system	-	SS-316
4.6	Flushing/ backwashing unit	-	SS-316
4.7	Backwash rotor shoes	-	Neoprene
4.8	Any other internal hardware /pipes etc.	-	SS-316 or eq.
4.9	Flushing Pump		
a)	Casing		SA 351 CF8M
b)	Impeller		SA 351 CF8M
c)	Shaft		SS 316
4.10	Valves	-	
4.10.1	Check Valves (65 NB & Above)		For sizes 65 NB and above-Swing check type or dual plate type.
	a) Body & Bonnet		SS316, Flanged Ends
	b) Disc for Check Valve		SS316
	c) Stem		ASTM A182 Gr F6a



TITLE :
DATA SHEET – A FOR
DEBRIS FILTER (DF)

SPECIFICATION NO. : PE-TS-410-165-N001

VOLUME : II B
BOOK: I

REV. NO. 00 DATE -25.06.2015

Page 4 of 9

S. No.	DESCRIPTION	UNITS	1x800MW KOTHAGUEDEM TPS UNIT-12-TSGENCO
--------	-------------	-------	---

4.10.2	Check Valves (50 NB & Below)		For size 50 NB and below-Piston type
	a) Body & Bonnet		SS-316, Socket welded Ends
	b) Disc for Check Valve		SS316
	c) Stem		ASTM A182 Gr F6a
4.10.3	Gate/ Globe Valves 50 Nb & Below		
	Body & Bonnet		SS-316, Socket welded Ends
4.10.4	➤ BF/Gate/Globe Valves (65NB & above)		Butterfly valves are applicable for sizes 400Nb and above.
	➤ Body & Disc		SA 351 CF8M
	➤ Shaft		ASTM A 182 F316
	➤ Stem		ASTM A182 Gr F6a
	➤ Sealing, Retaining segment & internals		18 – 8 SS
	➤ Bearings		Self lubricating
	➤ Companion Flange		SS316
	C) Ball valves		
	i) Body		SA 351 CF8M
	ii) Ball		SA 351 CF8M
	iii) Stem		SS 316
4.11	Debris discharge/ Interconnecting Piping	-	By Bidder



TITLE :
DATA SHEET – A FOR
DEBRIS FILTER (DF)

SPECIFICATION NO. : PE-TS-410-165-N001
VOLUME : II B
BOOK: I
REV. NO. 00 DATE -25.06.2015
Page 5 of 9

S. No.	DESCRIPTION	UNITS	1x800MW KOTHAGUEDEM TPS UNIT-12-TSGENCO
	Material		SS-316
4.12	Inspection hole	-	Required, 600 NB
5.0	COUNTER FLANGES		In Bidder's Scope
5.1	MATERIAL		Carbon steel to IS 2062 Gr.B, epoxy painted
5.2	Drilling Standard	-	ANSI B 16.5 or equivalent
6.0	Connecting pipe size (OD & Thk)	mm	2740X20
7.0	PAINTING		
7.1	External Surface	-	
	a) Surface preparation	-	SA 2.5 of Swedish Specification SIS 05.5900.197
	b) Primer		Epoxy based Zinc Phosphate
	c) Intermediate		Epoxy based TiO2 pigmented coat
	d) Final paint		Synthetic enamel paint to achieve DFT of 175 to 200 microns. Colour code shall be as per IS-1904 (Appendix-A)
7.2	Internal Surface		
	a) Surface preparation		SA 2.5 of Swedish Specification SIS 05.5900.197
	b) Primer		One coat of epoxy resin based primer
	c) Final paint		Applicable no. Of coats of coal tar epoxy paint to achieve total DFT of 200 to 250 microns



TITLE :

**DATA SHEET – A FOR
DEBRIS FILTER (DF)**

SPECIFICATION NO. : PE-TS-410-165-N001

VOLUME : II B

BOOK: I

REV. NO. 00 DATE -25.06.2015

Page 6 of 9

1x800MW KOTHAGUEDEM TPS UNIT-12-TSGENCO

S. No.	DESCRIPTION	UNITS	
8.0	SHOP TEST		
8.1	Hydrostatic test		
	a) Test Pressure	bar (g)	1.5 times design pressure
	b) Test duration	min.	30
8.2	Leakage test		
	a) Test Pressure	bar (g)	Design pressure
	b) Test duration	min.	30
9.0	Adequate provision for future installation of cathodic protection required		YES
10.0	Flow straightner for streamlining the CW flow in DF		If required as per bidder's design – the same to be incorporated by bidder in its constructional feature.
11.0	Performance Guarantee & Bid Evaluation		
11.1	Performance Parameters to be Guaranteed		
	❖ Pressure drop DF		As per Guarantee schedule of bidder
11.2	Bid evaluation Criteria & Liquidated damages		As per clause no 8.00.00 of Section C1
11.3	Bid evaluation rate		@ Rs 30 Lacs per 0.1 MWC pr. Drop across each DF
11.4	Liquidated damages		Twice the bid evaluation rate



TITLE :
DATA SHEET – A FOR
DEBRIS FILTER (DF)

SPECIFICATION NO. : PE-TS-410-165-N001

VOLUME : II B
BOOK: I

REV. NO. 00 DATE -25.06.2015

Page 7 of 9

S. No.	DESCRIPTION	UNITS	1x800MW KOTHAGUDEM TPS UNIT-12-TSGENCO
--------	-------------	-------	--

12.0	Whether automatic flushing/ back- washing operation effected by the following : i. Differential pressure ii. Adjustable timer iii. Push button		Yes Yes Yes
13.0	Whether provision for manual flushing / backwashing operation is made in the event of control system failure.		Yes
14.0	Whether built in flushing arrangement complete with flushing pump, valves, and associated piping, is provided.		YES (If required)
15.0	Mandatory Spare to be supplied under this specification		
15.1	Complete Set of Pump without Motor		One (1) set
15.2	Valve Complete Assembly		10% of each type and size of total population or minimum 1(one) No. whichever is higher
	C&I Spares		
15.3	Field Instruments		
15.3.1	Transmitters/ Gauges/Switches etc. along with relevant accessories		10% of total or at least two (whichever is higher) for each type along with accessories.
15.3.2	Temperature Element (RTD/Thermo-couple) with thermowell		10% of each type, range and immersion length. Minimum 5 nos.
15.3.3	Furnace Temperature Probe		Thermocouple 1 no.
15.4	Control Panel/ Desk		



TITLE :

DATA SHEET – A FOR
DEBRIS FILTER (DF)

SPECIFICATION NO. : PE-TS-410-165-N001

VOLUME : II B

BOOK: I

REV. NO. 00 DATE -25.06.2015

Page 8 of 9

S. No.	DESCRIPTION	UNITS	1x800MW KOTHAGUEDEM TPS UNIT-12-TSGENCO
15.4.1	Back-up panel mounted devices (Selector switches/ Push buttons/ Indicators etc.)		5% of installed capacity
15.4.2	Lamps/ LEDs		100% of the total quantity
15.4.3	Blank Tiles		10% of installed capacity
15.4.4	MCBs		10% of each type & rating
15.4.5	Fuses/ Fuse holder		100% of each type & rating
15.5	Annunciation System		
15.5.1	Each type of module		1(one) No. each
15.5.2	Lamp Box with Facia & Lamps (LED type)		5 (five) Nos.
15.5.3	Hooter		1 (one) No.
	<u>Electrical Spares</u>		
15.6	415 Volt Motor (above 30KW Rating upto 200KW)		
15.6.1	End Shield Cover Driving & Non-Driving End		1 Set for each type and rating of Motor
15.6.2	Driving End & Non-Driving End Bearing		1 Set for each type and rating of Motor
15.6.3	Cooling Fan		1 No. for each type and rating of Motor
15.6.4	Motor Space Heater		1 No. for each type and rating of Motor
15.6.5	Motor Terminal Block		1 No. for each type and rating of Motor



TITLE :

DATA SHEET – A FOR
DEBRIS FILTER (DF)

SPECIFICATION NO. : PE-TS-410-165-N001

VOLUME : II B

BOOK: I

REV. NO. 00 DATE -25.06.2015

Page 9 of 9

S. No.	DESCRIPTION	UNITS	1x800MW KOTHAGUEDEM TPS UNIT-12-TSGENCO
15.6.6	Complete Set of Coupling		1 Set for each Application
15.7	415 Volt Motor (Upto 30KW Rating)		
15.7.1	Driving End & Non-Driving End Bearing		3 Set for each type and rating of Motor
15.7.2	Cooling Fan		2 No. for each type and rating of Motor
15.7.3	Motor Terminal Block		5 No. for each type and rating of Motor
15.7.4	Complete Set of Coupling		1 Set for each Application

Notes for Mandatory Spares:

1. In case if such items of spares indicated as “not applicable” by bidder in its offer, are found applicable at a later date during execution of the project, such items of spares are to be supplied within the ordered cost of the mandatory spares.
2. Wherever % is indicated for the mandatory spares, the quantity shall be calculated for % of supply for total quantity for 1 unit of 1 x 800 MW, unless otherwise specified. The quantity to be reckoned for % indicated shall be rounded off to the next higher whole number. For example if the % arrived is 0.2 the quantity to be supplied shall be 1 and if the % arrived is 5.1 the quantity to be supplied shall be 6.
3. In respect of quantity mentioned as 'Set' means the total quantity of all the components/items used in particular equipment unless otherwise specified.

Pipe Size Table (Refer Cl. No. 6.5, Section C1, Vol-II)		
	Pipe CS	
NB	OD	Thick
15	21.80	3.2
25	34.20	4.0
50	60.80	4.5
100	115.00	5.4
150	166.50	5.4
200	219.10	6.0
250	273.00	6.0
300	323.90	6.0
350	355.60	6.0
400	406.40	6.0
700	711.00	7.0
800	813.00	8.0
900	914.00	10.0
1000	1016.00	10.0
1100	1118.00	10.0
1200	1219.00	11.0
1400	1422.00	14.2
2700	2740.00	20.0
3000	3040.00	20.0
3200	3240.00	20.0
3400	3440.00	20.0

	TITLE : DATA SHEET - C DEBRIS FILTER (Backwash Type)	SPECIFICATION NO. PE-TS- 999-165-N003	
		VOLUME : II B	
		SECTION : D	
		REV. NO. 03	DATE : 29.07.2007
		SHEET 1 OF 2	
1.00.00	<u>DRAWINGS, DATA AND INFORMATION TO BE SUBMITTED AFTER THE AWARD OF CONTRACT :</u> After the award of contract, the following drawings, data and information is to be submitted for review / approval of BHEL as per the distribution schedule given in Section -C.		
1.01.00	Within 3(three) weeks of the data of LOI, the following shall be submitted :		
1.01.01	Data Sheet -B duly revised conforming to accepted bid.		
1.01.02	Final versions of the following drawings to enable BHEL to finalise the layout and to design foundations and structures.		
	a) General arrangement / Installation drawings of the Debris Filter with all accessories, indicating the principal dimensions and weights of equipment offered, size and location of various nozzle connections, withdrawal space and scope of supply etc.		
	b) Foundation arrangement drawings (wherever applicable) showing load data on supports, size and location of anchor bolts etc.		
1.02.00	<u>With in the stipulated time period as per vendor's drawing/document list, the following shall be submitted :</u>		
1.02.01	Cross-sectional/detailed drawings of filter housing/body, filter screen/section assembly, flushing / backwash unit, differential pressure measuring system, actuators, motors, control panel etc. indicating bill of quantities and materials of construction.		
1.02.02	Flow and control logic diagrams for complete filter during normal and flushing operation and system write-up covering all modes of operation.		
1.02.03	Final version of performance evaluation procedures at site.		
1.02.04	Detailed schedule of valves indicating tag numbers, type, make, size, pressure & temperature ratings, materials etc.		
1.02.05	Detailed schedule of power & control cable.		
1.02.06	Detailed schedule of piping and fittings indicating sizes, materials, maximum working pressure & temperatures etc.		
1.02.07	Control panel layout and list of instruments provided on control panel and internal wiring diagrams.		
1.02.08	List of annunciations, protections and interlocks provided.		

	TITLE : DATA SHEET - C DEBRIS FILTER (Backwash Type)	SPECIFICATION NO. PE-TS- 999-165-N003	
		VOLUME : II B	
		SECTION : D	
		REV. NO. 03	DATE : 29.07.2007
		SHEET 2	OF 2

- 1.02.09 Detailed drawings of flanges.
- 1.02.10 Quality Plan
- 1.02.11 Material test certificates.
- 1.02.12 Shop tests reports and certificates.
- 1.02.13 Write-up and instruction manuals for erection, operation and maintenance.
- 1.02.14 Storage instructions.
- 1.02.15 Vendor to send 3 sets of final documents (O&M Manual, GA drg, P&ID) direct to site under intimation to PEM.

BHEL Logo		Manufacturer's Name & Address		STANDARD QUALITY PLAN		BHEL Doc No.: PE-V3-XXX-165-N008				
Sl. No.	Component / Operation	Characteristics Checked	Class	Type of Check	Quantum of Check	Reference Documents	Acceptance Norms	Format of Record	Agency	Remarks
1	2	3	4	5	6	7	8	9	M C O	11
1.2.0	Inprocess Quality Control									
1.2.1	Welding procedure specification	Correctness	Critical	Scrutiny	100%	ASME Sec. IX	ASME Sec. IX	QW 482 of ASME Sec. IX	P	V
1.2.2	Welding procedure qualification	Weld soundness	Critical	Physical test	100%	ASME Sec. IX	ASME Sec. IX	QW 483 of ASME Sec. IX	P	V
1.2.3	Welder performance qualification	Weld soundness	Critical	Physical test	100%	ASME Sec. IX	ASME Sec. IX	QW 484 of ASME Sec. IX	P	V
1.2.4	Fit-up of butt weld	Alignment and dimensions	Major	Template, visual	100%	Manufacturing Drawing	ASME Sec. VIII Div. I	Log book	P	V
1.2.5	Fit-up of shell flange and nozzle assembly to shell	Orientation, alignment and dimensions	Major	Template, visual	100%	Manufacturing Drawing	ASME Sec. VIII Div. I	Log book	P	V
1.2.6	Weld quality for Pressure Parts									
	(a) Root run	Surface defects	Major	Penetrant test / Visual	100%	ASME Sec. VIII Div. I / sec V	ASME Sec. VIII Div. Appendix 8	Operation Process Sheet	P	V
	(e) Completed butt welds	1. Surface defects	Major	Penetrant test	100%	ASME Sec. VIII Div. I / sec V	ASME Sec. VIII Div. Appendix 8	Inspection report	P	V
		2. Sub-surface defects	Critical	Radiography test	10% of total weld length + 100% T Joints.	ASME Sec. VIII Div. I / sec V	ASME Sec. VIII Div. Appendix 4 / UW 52	Radiographs and inspection report	P	V
	(b) Completed fillet welds	Surface defects	Major	Penetrant test	100%	ASME Sec. VIII Div. I / sec V	ASME Sec. VIII Div. Appendix 8	Inspection report	P	V
<p>LEGEND</p> <p>* Records identified with "STAR" shall be essentially included by contractor in QA Documentation.</p> <p>** M : Manufacturer / Sub-contractor</p> <p>C : Contractor</p> <p>O : Owner</p> <p>Contractor</p> <p>Manufacturer / Sub-Contractor Signature</p>										
<p>Name & Sign. Of approving authority & Seal</p>										

Manufacturer's Name & Address		STANDARD QUALITY PLAN							BHEL Doc No.:	
Item :		Vendor Q.P. NO.	PACKAGE : DEBRIS FILTER	PROJECT:	PE -V3-XXX- 165- N008					
P.O. No.		DEBRIS FILTER	Date :	CUSTOMER:						
Characteristics Checked		Class	Type of Check	Quantum of Check	Reference Documents	Acceptance Norms	Format of Record	Agency	Remarks	
Sl. No.	Component / Operation	3	4	5	6	7	8	M	C	O
1	2	3	4	5	6	7	8	9	10	11
1.2.8	Pickling and Passivation	Protection Layer	Major	Visual	100%	IS : 10117	Log Book	P		
1.2.9	Fabricated Shell (Prior to sand blasting)	1.Dimensions, Orientation 2. Hydro test	Major Critical	Measurement by visual Hydrostatic Pr. @ 1.5 times of design pr.(positive) [Duration includes] 30 minutes	by 100%	Manufacturing Drawing ASME Sec.VIII Div.1	Manufacturing Drawing Inspection report	* *	V V	V V
1.3.0	Final tests (completed equipments) - After assembly	1.Dimensions, orientation, workmanship & finish 2. Leak tightness for assembly 3.Dry function test for Debris filter	Major Critical Critical	Measurement by visual Leak test @ design pr.(positive) [Duration includes] 30 minutes Operational test	by 100%	G.A.drawing ASME Sec.VIII Div.1 Approved PROC	Inspection report Inspection report Inspection report	* * *	V W W	V V V
1.4.0	Rubber Lining (Shell)									
1.4.1	Rubber Formulation	Tensile, elongation & hardness Polymer identification	Major Major	Physical test Flame test	One per lot One per lot	Manufacturer's procedure For Semi Ebonite Polymer/Ebonite Polymer catches fire and on removal from fire fire continues to burn	Manufacturers certificate Inspection report	* *	V V	V V
1.4.2	Surface preparation of items to be lined	% Change in weight after 24 hours of immersion in sea water at 70°	Major	Immersion test (bleeding test)	One per lot	ASTM D 471	Inspection report		P	V
1.4.3	Vulcanising	Free from rust, scale,dust & grease Temperature, Pressure & Time	Major	Visual	100%	SA 2.5	Manufacturers Inspection report		P	-
1.4.4	Vulcanised Rubber Lined items	[a] Chip test [b] Adhesion, Visual defects, Thickness & Hardness [c] Spark test for Pin Holes at 5 kv/mm	Major Major Major	Process monitoring Chip test Measurement, Visual Inspection	100% 100% 100%	Manufacturer's procedure Approved Drawing & BS 6374/Equivalent Approved Drawing & BS 6374/Equivalent	Process Procedure Inspection report Inspection report	* * *	P P P	- - V
<p>LEGEND</p> <p>* Records Identified with "STAR" shall be essentially included by contractor in QA Documentation.</p> <p>** M : Manufacturer/ Sub-contractor C : Contractor O : Owner</p> <p>Indicate : "P" - Perform, "W" - Witness and "V" - Verification</p>										
<p>Manufacturer / Sub-Contractor Signature</p>										
<p>Contractor Signature</p>										
<p>Name & Sign. Of approving authority & Seal</p>										

Manufacturer's Name & Address		Item : Ball Valve		STANDARD QUALITY PLAN		BHEL Doc No.: PE -V3-XXX- 165- N008		
P.O. No.		Vendor Q.P. NO.		PROJECT:		CUSTOMER:		
		Date :		PURCHASER:		CONSULTANT:		
		Page 05 of 10		Format of Record		Remarks		
Sl. No.	Component / Operation	Class	Type of Check	Quantum of Check	Reference Documents	Acceptance Norms	Agency	
1	2	3	4	5	6	7	8	
2.4.0	Ball valves							
2.4.1	Materials							
	Body and Tail end pieces	Major	Chemical & Physical analysis	One Sample/Cast / heat	Approved drg/ Data sheet	Approved drg/ Data sheet	Manufacturer's T.C.	* P V V
2.4.2	Ball	Major	Chemical & Physical analysis	One Sample/Cast / heat	Approved drg/ Data sheet	Approved drg/ Data sheet	Manufacturer's T.C.	* P V V
2.4.3	Stem	Major	Chemical & Physical analysis	One Sample/Cast / heat	Approved drg/ Data sheet	Approved drg/ Data sheet	Manufacturer's T.C.	* P V V
2.4.4	In-process inspection							
2.4.5	Machining of body, end, pieces, ball	Major	Measurement	100%	Approved drg/Data sheet	Approved drg/Data sheet	Log book	- P V V
2.4.6	Ball	Critical	Penetrant test	100%	ASME Sec.VIII Div.1	ASME Sec.VIII Div.1 Appendix 8	Inspection report	* P V V
		Major	Hardness testing	Random	Approved drg/Data sheet	Approved drg/Data sheet	Inspection report	* P V V
2.4.7	Assembly	Major	Measurement	100%	EN ISO 17292	EN ISO 17282	Manufacturer's T.C.	* P V V
		Major	Operation	100%	---	As per approved data sheet	-	- P V V
2.4.8	Testing							
	[a] Body	Critical	Hydraulic test	100%	EN 12266-1&2/API 598 & 598/Appd data sheet	EN 12266-1&2/API 598 & 598/Appd Data sheet	Manufacturer's T.C.	* P V V
	[b] Seat test	Critical	Hydraulic test	100%	EN 12266-1&2/API 598 & 598/Appd data sheet	EN 12266-1&2/API 598 & 598/Appd Data sheet	Manufacturer's T.C.	* P V V
	[c] Seat	Critical	Air test	100%	EN 12266-1&2/API 598 & 598/Appd data sheet	EN 12266-1&2/API 598 & 598/Appd Data sheet	Manufacturer's T.C.	* P V V
LEGEND								
* Records identified with "STAR" shall be essentially included by contractor in QA Documentation								
** M : Manufacturer / Sub-contractor								
C : Contractor								
O : Owner								
Indicate : "P" - Perform, "W" - Witness and "V" - Verification								
Manufacturer / Sub-Contractor Signature		Contractor						
								Name & Sign. Of approving authority & Seal

Sl. No.		Component / Operation		Manufacturer's Name & Address		STANDARD QUALITY PLAN		BHEL Doc No.:		PE-VS-XXX-165-N008	
		Item :		Vendor Q.P. NO.		PROJECT:		CUSTOMER:			
		Worm Planetary Gear box		PACKAGE : DEBRIS FILTER		Date :		PURCHASER:			
		Actuators		Page 08 of 10				CONSULTANT:			
Sl. No.	Component / Operation	Characteristics Checked	Class	Type of Check	Quantum of Check	References Documents	Acceptance Norms	Format of Record	Agency	Remarks	
1			4	5	6	7	8	9	M C O		11
7.0.0	GEARED MOTOR DRIVE	Running Test	Critical	Functional Test	100%	Approved Data Sheet	Approved Data Sheet	Manufacturer's compliance certificate	P	V	V
		No load	Critical	Functional test	100%	Approved Data Sheet	Approved Data Sheet		P	V	V
		Noise test	Critical	Functional test	100%	Approved Data Sheet	Approved Data Sheet		P	V	V
		Oil leakage test	Critical	Functional test	100%	Approved Data Sheet	Approved Data Sheet		P	V	V
		Visual	Critical	-	100%	Approved Data Sheet	Approved Data Sheet		P	V	V
		Name plate verification	Critical	-	100%	Approved Data Sheet	Approved Data Sheet		P	V	V
8.0.0	Complete Unit of planetary gear	No Leak Test	Critical	Functional test	One Sample/lot	Approved Data Sheet	Data Supplier Catalogue	Manufacturer's compliance certificate	P	V	V
		Noise Level	Minor	Functional test	One Sample/lot	Approved Data Sheet	Approved Data Sheet		P	V	V
		Visual Name plate Verification	Minor	-	100%	Approved Data Sheet	Approved Data Sheet		P	V	V
9.0.0	Actuators	Functional test	Major	Electrical test	100%	Supplier catalogue/Appd data sheet	Supplier catalogue/Appd data sheet		P	V	V
		Make, Range, Model	Major	Visual	100%	Supplier catalogue/Appd data sheet	Supplier catalogue/Appd data sheet	Inspection Report	P	-	-
		Assembly check alongwith valves	Major	Visual	100%	Supplier catalogue/Appd data sheet	Supplier catalogue/Appd data sheet	Inspection Report	P	-	-
		Functional Check along with settings / Auxiliary Contacts	Major	Visual	100%	Supplier catalogue	Supplier catalogue/Appd data sheet	Inspection Report	P	-	-
											Review of TC's
LEGEND											
* Records identified with "STAR" shall be essentially included by contractor in QA Documentation											
** M - Manufacturer/ Sub-contractor											
C - Contractor											
O - Owner											
Indicate : "P" - Perform, "W" - Witness and "V" - Verification											
Manufacturer / Sub-Contractor Signature											
Contractor											
Name & Sign. Of approving authority & Seal											

Manufacturer's Name & Address		STANDARD QUALITY PLAN		BHEL Doc No.:					
Item :		Vendor Q.P. NO.		PE-V3-XXX- 165- N008					
Fasteners		PACKAGE : DEBRIS FILTER		PROJECT :					
All Components & Equipments		Date :		CUSTOMER:					
		Page 10 of 10		PURCHASER:					
				CONSULTANT:					
Sl. No.	Component / Operation	Class	Type of Check	Quantum of Check	Reference Documents	Acceptance Norms	Format of Record	Agency	Remarks
1	11.1.0 Fasteners	4	5	6	7	8	9	M C O	11
11.1.1	Internal Fasteners (Duplex SS)	Major	Chemical Mechanical analysis	& 1 Per heat/HT Batch	Approved drg/Data sheet	Approved drg/Data sheet	Mfr's TC / Lab Report	P V V	
	Visual & workmanship finish	Major	Visual	Sample	Approved drg/Data sheet	Approved drg/Data sheet	Inspection Report	P V V	
	Dimensions	Major	Measurement	Sample	Approved drg/Data sheet	Approved drg/Data sheet	Inspection Report	P V V	
11.1.2	Main Fasteners	Major	Visual	Sample	Approved drg/Data sheet	Approved drg/Data sheet	Inspection report / Mfr TC	P V V	
	Dimensions	Major	Measurement	Sample	Approved drg/Data sheet	Approved drg/Data sheet	Inspection report / Mfr TC	P V V	
	Chemical & Physical properties	-	Chemical Physical test a) Tensile b) Yield c) Elongation d) Proof load	& 1 sample per heat	Approved drg/Data sheet	Approved drg/Data sheet	Mfr TC/Lab report	P V V	
12.0.0 All Components / Equipments									
	Painting Dry film thickness and	Major	Measurement	Random	Painting schedule	Painting schedule	Inspection report	P V V	
	Packing	Major	Measurement	100%	Packing Procedure	Packing Procedure	Inspection report	P - -	
LEGEND * Records identified with "STAR" shall be essentially included by contractor in QA Documentation. ** M : Manufacturer/ Sub-contractor C : Contractor O : Owner Indicate : "P" - Perform, "W" - Witness and "V" - Verification									
Manufacturer/ Sub-Contractor Signature									
Contractor Signature									
Name & Sign. Of approving authority & Seal									



**TITLE : TECHNICAL SPECIFICATION
FOR
DEBRIS FILTER (DF)**

SPEC. NO. PE-TS- 410-165-N001

VOLUME : IIB

SECTION : D

REV. NO. 0

**DATE :
18.06.2015**

SHEET 1 of 1

**SECTION D2
STANDARD TECHNICAL SPECIFICATION
FOR
ELECTRICAL SYSTEMS**



TITLE :
GENERAL TECHNICAL REQUIREMENTS

FOR

LV MOTORS

SPECIFICATION NO. PE-SS-999-506-E101
VOLUME NO. : II-B
SECTION : D
REV NO. : 00 DATE : 29/08/2005
SHEET : 1 OF 1

GENERAL TECHNICAL REQUIREMENTS

FOR

LV MOTORS

SPECIFICATION NO.: PE-SS-999-506-E101 Rev 00



TITLE :
GENERAL TECHNICAL REQUIREMENTS

FOR

LV MOTORS

SPECIFICATION NO.
PE-SS-999-506-E101
VOLUME NO. : **II-B**
SECTION : **D**
REV NO. : **00** DATE : 29/08/2005
SHEET : 1 OF 4

1.0 INTENT OF SPECIFICATION

The specification covers the design, materials, constructional features, manufacture, inspection and testing at manufacturer's work, and packing of Low voltage (LV) squirrel cage induction motors along with all accessories for driving auxiliaries in thermal power station.

Motors having a voltage rating of below 1000V are referred to as low voltage (LV) motors.

2.0 CODES AND STANDARDS

Motors shall fully comply with latest edition, including all amendments and revision, of following codes and standards:

IS:325	Three phase Induction motors
IS : 900	Code of practice for installation and maintenance of induction motors
IS: 996	Single phase small AC and universal motors
IS: 4722	Rotating Electrical machines
IS: 4691	Degree of Protection provided by enclosures for rotating electrical machines
IS: 4728	Terminal marking and direction of rotation rotating electrical machines
IS: 1231	Dimensions of three phase foot mounted induction motors
IS: 8789	Values of performance characteristics for three phase induction motors
IS: 13555	Guide for selection and application of 3-phase A.C. induction motors for different types of driven equipment
IS: 2148	Flame proof enclosures for electrical appliance
IS: 5571	Guide for selection of electrical equipment for hazardous areas
IS: 12824	Type of duty and classes of rating assigned
IS: 12802	Temperature rise measurement for rotating electrical machines
IS: 12065	Permissible limits of noise level for rotating electrical machines
IS: 12075	Mechanical vibration of rotating electrical machines

In case of imported motors, motors as per IEC-34 shall also be acceptable.

3.0 DESIGN REQUIREMENTS

3.1 Motors and accessories shall be designed to operate satisfactorily under conditions specified in data sheet-A and Project Information, including voltage & frequency variation of supply system as defined in Data sheet-A

3.2 Motors shall be continuously rated at the design ambient temperature specified in Data Sheet-A and other site conditions specified under Project Information
Motor ratings shall have at least a 15% margin over the continuous maximum demand of the driven equipment, under entire operating range including voltage & frequency variation specified above.

3.3 Starting Requirements

3.3.1 Motor characteristics such as speed, starting torque, break away torque and starting time shall be properly co-ordinated with the requirements of driven equipment. The accelerating torque at any speed with the minimum starting voltage shall be at least 10% higher than that of the driven equipment.

3.3.2 Motors shall be capable of starting and accelerating the load with direct on line starting without exceeding acceptable winding temperature.



TITLE :
GENERAL TECHNICAL REQUIREMENTS

FOR

LV MOTORS

SPECIFICATION NO.
PE-SS-999-506-E101
VOLUME NO. : **II-B**
SECTION : **D**
REV NO. : **00** DATE : 29/08/2005
SHEET : 2 OF 4

The limiting value of voltage at rated frequency under which a motor will successfully start and accelerate to rated speed with load shall be taken to be a constant value as per Data Sheet - A during the starting period of motors.

3.3.3 The following frequency of starts shall apply

- i) Two starts in succession with the motor being initially at a temperature not exceeding the rated load temperature.
- ii) Three equally spread starts in an hour the motor being initially at a temperature not exceeding the rated load operating temperature. (not to be repeated in the second successive hour)
- iii) Motors for coal conveyor and coal crusher application shall be suitable for three consecutive hot starts followed by one hour interval with maximum twenty starts per day and shall be suitable for minimum 20,000 starts during the life time of the motor

3.4 **Running Requirements**

3.4.1 Motors shall run satisfactorily at a supply voltage of 75% of rated voltage for 5 minutes with full load without injurious heating to the motor.

3.4.2 Motor shall not stall due to voltage dip in the system causing momentary drop in voltage upto 70% of the rated voltage for duration of 2 secs.

3.5 **Stress During bus Transfer**

3.5.1 Motors shall withstand the voltage, heavy inrush transient current, mechanical and torque stress developed due to the application of 150% of the rated voltage for at least 1 sec. caused due to vector difference between the motor residual voltage and the incoming supply voltage during occasional auto bus transfer.

3.5.2 Motor and driven equipment shafts shall be adequately sized to satisfactorily withstand transient torque under above condition.

3.6 Maximum noise level measured at distance of 1.0 metres from the outline of motor shall not exceed the values specified in IS 12065.

3.7 The max. vibration velocity or double amplitude of motors vibration as measured at motor bearings shall be within the limits specified in IS: 12075.

4.0 **CONSTRUCTIONAL FEATURES**

4.1 Indoor motors shall conform to degree of protection IP: 54 as per IS: 4691. Outdoor or semi-indoor motors shall conform to degree of protection IP: 55 as per IS: 4691 and shall be of weather-proof construction. Outdoor motors shall be installed under a suitable canopy

4.2 Motors upto 160KW shall have Totally Enclosed Fan Cooled (TEFC) enclosures, the method of cooling conforming to IC-0141 or IC-0151 of IS: 6362.

Motors rated above 160 KW shall be Closed Air Circuit Air (CACA) cooled

4.3 Motors shall be designed with cooling fans suitable for both directions of rotation.

	TITLE :	SPECIFICATION NO.
	GENERAL TECHNICAL REQUIREMENTS	PE-SS-999-506-E101
	FOR	VOLUME NO. : II-B
	LV MOTORS	SECTION : D
		REV NO. : 00 DATE : 29/08/2005
	SHEET : 3 OF 4	

- 4.4. Motors shall not be provided with any electric or pneumatic operated external fan for cooling the motors.
- 4.5. Frames shall be designed to avoid collection of moisture and all enclosures shall be provided with facility for drainage at the lowest point.
- 4.6. In case Class 'F' insulation is provided for LV motors, temperature rise shall be limited to the limits applicable to Class 'B' insulation.
In case of continuous operation at extreme voltage limits the temperature limits specified in table-1 of IS:325 shall not exceed by more than 10°C.
- 4.7 Terminals and Terminal Boxes**
- 4.7.1 Terminals, terminal leads, terminal boxes, windings tails and associated equipment shall be suitable for connection to a supply system having a short circuit level, specified in the Data Sheet-A.

Unless otherwise stated in Data Sheet-A, motors of rating 110 kW and above will be controlled by circuit breaker and below 110 kW by switch fuse-contactor. The terminal box of motors shall be designed for the fault current mentioned in data sheet "A".
- 4.7.2 unless otherwise specified or approved, phase terminal boxes of horizontal motors shall be positioned on the left hand side of the motor when viewed from the non-driving end.
- 4.7.3 Connections shall be such that when the supply leads R, Y & B are connected to motor terminals A B & C or U, V & W respectively, motor shall rotate in an anticlockwise direction when viewed from the non-driving end. Where such motors require clockwise rotation, the supply leads R, Y, B will be connected to motor terminals A, C, B or U W & V respectively.
- 4.7.4 Permanently attached diagram and instruction plate made preferably of stainless steel shall be mounted inside terminal box cover giving the connection diagram for the desired direction of rotation and reverse rotation.
- 4.7.5 Motor terminals and terminal leads shall be fully insulated with no bar live parts. Adequate space shall be available inside the terminal box so that no difficulty is encountered for terminating the cable specified in Data Sheet-A.
- 4.7.6 Degree of protection for terminal boxes shall be IP 55 as per IS 4691.
- 4.7.7 Separate terminal boxes shall be provided for space heaters.. If this is not possible in case of LV motors, the space heater terminals shall be adequately segregated from the main terminals in the main terminal box. Detachable gland plates with double compression brass glands shall be provided in terminal boxes.
- 4.7.8. Phase terminal boxes shall be suitable for 360 degree of rotation in steps of 90 degree for LV motors.
- 4.7.9 Cable glands and cable lugs as per cable sizes specified in Data Sheet-A shall be included. Cable lugs shall be of tinned Copper, crimping type.
- 4.8 Two separate earthing terminals suitable for connecting G.I. or MS strip grounding conductor of size given in Data Sheet-A shall be provided on opposite sides of motor frame. Each terminal box shall have a grounding terminal.



TITLE :
GENERAL TECHNICAL REQUIREMENTS

FOR

LV MOTORS

SPECIFICATION NO.
PE-SS-999-506-E101
VOLUME NO. : **II-B**
SECTION : **D**
REV NO. : **00** DATE : 29/08/2005
SHEET : 4 OF 4

- 4.9.1 Motors provided for similar drives shall be interchangeable.
- 4.9.2 Suitable foundation bolts are to be supplied alongwith the motors.
- 4.9.3 Motors shall be provided with eye bolts, or other means to facilitate safe lifting if the weight is 20Kgs. and above.
- 4.9.4 Necessary fitments and accessories shall be provided on motors in accordance with the latest Indian Electricity rules 1956.
- 4.9.5 All motors rated above 30 kW shall be provided with space heaters to maintain the motor internal air temperature above the dew point. Unless otherwise specified, space heaters shall be suitable for a supply of 240V AC, single phase, 50 Hz.
- 4.9.6 Name plate with all particulars as per IS: 325 shall be provided
- 4.9.7 Unless otherwise specified, the colour of finish shall be grey to Shade No. 631 and 632 as per IS:5 for motors installed indoor and outdoor respectively. The paint shall be epoxy based and shall be suitable for withstanding specified site conditions.

5.0 INSPECTION AND TESTING

- 5.1 All materials, components and equipments covered under this specification shall be procured, manufactured, as per the BHEL standard quality plan No. PED-506-00-Q-006/0 and PED-506-00-Q-007/2 enclosed with this specification and which shall be complied.
- 5.2 LV motors of type-tested design shall be provided. Valid type test reports not more than 5 year shall be furnished. In the absence of these, type tests shall have to be conducted by manufacturer without any commercial implication to purchaser.
- 5.3 All motors shall be subjected to routine tests as per IS: 325 and as per BHEL standard quality plan.
- 5.4 Motors shall also be subjected to additional tests, if any, as mentioned in Data Sheet A.

6.0 DRAWINGS TO BE SUBMITTED AFTER AWARD OF CONTRACT

- a) OGA drawing showing the position of terminal boxes, earthing connections etc.
- b) Arrangement drawing of terminal boxes.
- c) Characteristic curves:
(To be given for motor above 55 kW unless otherwise specified in Data Sheet).
 - i) Current vs. time at rated voltage and minimum starting voltage.
 - ii) Speed vs. time at rated voltage and minimum starting voltage.
 - iii) Torque vs. speed at rated voltage and minimum voltage.
For the motors with solid coupling the above curves i), ii), iii) to be furnished for the motors coupled with driven equipment. In case motor is coupled with mechanical equipment by fluid coupling, the above curves shall be furnished with and without coupling.
 - iv) Thermal withstand curve under hot and cold conditions at rated voltage and max. permissible voltage.



TITLE

LV MOTORS**DATA SHEET-A**

SPECIFICATION NO.

VOLUME II B

SECTION D

REV NO. 00 DATE 15.06.2015

SHEET 1 OF 1

- 1.0 Design ambient temperature : 50 °C
- 2.0 Maximum acceptable kW rating of LV motor: Below 175KW
- 3.0 Installation (Indoors/ Outdoors) : As required
- 4.0 Degree Of Protection (Indoor/Outdoor) : IP54/IP55
- 5.0 Type of Cooling : TEFC/CACA/TETV
- 6.0 Details of supply system
- a) Rated voltage (with variation) : 415V \pm 10%
 - b) Rated frequency (with variation) : 50 Hz (Variation: +3% to -5%)
 - c) Combined voltage & freq. variation : 10% (absolute sum)
 - d) System fault level at rated voltage : 50 kA for 1 sec
 - e) Short time rating for terminal boxes
 - o 110kW & Above : 50 kA for 1 sec
(Breaker controlled)
 - o Below 110kW : 50 KA for 0.20 sec.
(Contactor controlled)
 - f) LV System grounding : Solidly
- 7.0 Class of insulation : Class 'F' with temp rise limited to class B
- 8.0 Minimum voltage for starting : 80% of rated voltage
(As percentage of rated voltage)
- 9.0 Power cables data : Shall be given during Detailed engg.
- 10.0 Earth Conductor Size & Material : Shall be given during Detailed engg.
- 11.0 Space heater supply : 240 V, 1 Φ , 50 Hz
- 12.0 Rating up to which Single phase motor : Acceptable upto 0.20 kW
- 13.0 Tests : As per Customer motor spec.(enclosed)
- 14.0 Energy efficient/ Flame proof motor : As per Customer spec. requirement
- 14.0 Makes : AS PER ANNEXURE-I

NOTE :**1. Also detail Customer spec. for Motors is to be referred as enclosed with technical spec.**

		QUALITY PLAN			CUSTOMER		PROJECT		SPECIFICATION :			
					TSPGCL		1 X 800 MW KOTHAGUDEM TPS		NUMBER :			
SHEET 1 OF 9		CHARACTERISTIC CHECK			BIDDER/		QUALITY PLAN		SPECIFICATION :			
					VENDOR		NUMBER PED-506-00-Q-007, REV-03		TITLE			
SL. NO.	COMPONENT/OPERATION	CAT.	TYPE/METHOD OF CHECK	EXTENT OF CHECK	REFERENCE DOCUMENT	ACCEPTANCE NORM	FORMAT OF RECORD	SECTION			VOLUME III	
1	2	3	4	5	6	7	8	9	10			11
									P	W	V	REMARKS
1.0	RAW MATERIAL & BOUGHT OUT CONTROL											
1.1	SHEET STEEL, PLATES, SECTION, EYEBOLTS	1.SURFACE CONDITION	MA	VISUAL	100%	-	FREE FROM BLINKS, CRACKS, WAVINESS ETC	LOG BOOK	3	-	-	
		2.DIMENSIONS	MA	MEASUREMENT	SAMPLE	MANFR'S DRG./SPEC	MANFR'S DRG./SPEC	-DO-	3	-	-	
		3.PROOF LOAD TEST (EYE BOLT)	MA	MECH. TEST	-DO-	-DO-	-DO-	INSPEC. REPORT	3	-	2	
1.2	HARDWARES	1.SURFACE CONDITION	MA	VISUAL	100%		FREE FROM CRACKS, UNEVENNESS ETC.	-DO-	3	-	-	
		2.PROPERTY CLASS	MA	VISUAL	SAMPLES	MANFR'S DRG./SPEC BOOK	RELEVANT IS/SPEC.	SUPPLIER'S TC & LOG	3	-	2	PROPERTY CLASS MARKING SHALL BE CHECKED BY THE VENDOR
1.3	CASTING	1.SURFACE CONDITION	MA	VISUAL	100%		FREE FROM CRACKS, BLOW HOLES ETC.	LOG BOOK	3	-	2	
		2.CHEM. & PHY. PROP.	MA	CHEM & MECH TEST	1/HEAT NO.	MANFR'S DRG./SPEC	RELEVANT IS/	SUPPLIER'S TC	3	-	2	HEAT NO. SHALL BE VERIFIED
		3.DIMENSIONS	MA	MEASUREMENT	100%	MANUFR'S DRG.	MANUFR'S DRG.	LOG BOOK	3	-	2	
1.4	PAINT & VARNISH	1.MAKE, SHADE, SHELF LIFE & TYPE	MA	VISUAL	100% CONTINUOUS	MANFR'S DRG./SPEC	MANFR'S DRG./SPEC	LOG BOOK	3	-	2	
BHEL			PARTICULARS			BIDDER/VENDOR						
			NAME									
			SIGNATURE									
			DATE						BIDDER'S/VENDORS COMPANY SEAL			



QUALITY PLAN

SHEET 2 OF 9

CUSTOMER TSPGCL

PROJECT 1 X 800 MW KOTHAGUDEM TPS

SPECIFICATION :

NUMBER :

BIDDER/

QUALITY PLAN

SPECIFICATION :

VENDOR

NUMBER PED-506-00-Q-007, REV-03

TITLE

SYSTEM

ITEM: AC ELECT. MOTORS 55 KW & ABOVE (LV & MV)

SECTION

VOLUME III

SL. NO.	COMPONENT/OPERATION	CHARACTERISTIC CHECK	CAT.	TYPE/METHOD OF CHECK	EXTENT OF CHECK	REFERENCE DOCUMENT	ACCEPTANCE NORM	FORMAT OF RECORD	AGENCY			REMARKS
									P	W	V	
1	2	3	4	5	6	7	8	9	10			11
1.5	SHAFT (FORGED OR ROLLED)	1. SURFACE COND.	MA	VISUAL	100%	-	FREE FROM VISUAL DEFECTS	-DO-	3	-	-	VENDOR'S APPROVAL IDENTIFICATION SHALL BE MAINTAINED
		2. CHEM. & PHYSICAL PROPERTIES	MA	CHEM. & PHYSICAL TESTS	1/HEAT NO. OR HEAT TREATMENT BATCH NO	MFG. DRG. SPEC.	RELEVANT IS	SUPPLIER'S TC	3	-	2	
		3. DIMENSIONS	MA	MEASUREMENT	100%	-DO-	MANUFR'S DRG.	LOG BOOK	3	-	2	
		4. INTERNAL FLAWS	CR	UT	-DO-	ASTM-A388	MANUFR'S SPEC. BHEL SPEC.	-DO-	3	2	1	
1.6	SPACE HEATERS, CONNECTORS, TERMINAL BLOCKS, CABLES, CABLE LUGS, CARBON BRUSH TEMP. DETECTORS, RTD, BTD'S	1. MAKE & RATING	MA	VISUAL	-DO-	MANUFR'S DRG. SPEC.	MANUFR'S DRG. SPEC.	-DO-	3	-	2	
		2. PHYSICAL COND.	MA	-DO-	-DO-	-	NO PHYS. DAMAGE. NO ELECTRICAL DISCONTINUITY	-DO-	3	-	2	
		3. DIMENSIONS (WHEREVER APPLICABLE)	MA	MEASUREMENT	SAMPLE	MANUFR'S DRG./ SPEC.	MANUFR'S DRG. / SPEC.	-DO-	3	-	2	
		4. PERFORMANCE/ CALIBRATION	MA	TEST	100%	-DO-	-DO-	INSP. REPORT	3	-	2	
BHEL			PARTICULARS			BIDDER/VENDOR						
			NAME									
			SIGNATURE									
			DATE						BIDDER'S/VENDORS COMPANY SEAL			



QUALITY PLAN

SHEET 3 OF 9

CUSTOMER TSPGCL

PROJECT TITLE 1 X 800 MW KOTHAGUDEM TPS

SPECIFICATION :
NUMBER :

BIDDER/ VENDOR :
SYSTEM

QUALITY PLAN
NUMBER PED-506-00-Q-007, REV-03

SPECIFICATION :
TITLE

ITEM: AC ELECT. MOTORS 55 KW & ABOVE (LV & MV)

SECTION VOLUME III

SL. NO.	COMPONENT/OPERATION	CHARACTERISTIC CHECK	CAT.	TYPE/METHOD OF CHECK	EXTENT OF CHECK	REFERENCE DOCUMENT	ACCEPTANCE NORM	FORMAT OF RECORD	AGENCY			REMARKS
									P	W	V	
1	2	3	4	5	6	7	8	9	10			11
1.7	OTHER INSULATING MATERIALS LIKE SLEEVES, BINDINGS CORDS, PAPERS, PRESS BOARDS ETC.	1. SURFACE COND. ETC. 2. OTHER CHARACTERISTICS	MA MA	VISUAL TEST	100% SAMPLE	- MANUF'S SPEC.	NO VISUAL DEFECTS MANUF'S SPEC.	INSPT. REPORT LOG BOOK AND OR SUPPLIER'S TC	3 3	- -	2 2	
1.8	SHEET STAMPING (PUNCHED)	1. SURFACE COND. 2.DIMENSIONS INCLUDING BURS HEIGHT 3. ACCEPTANCE TESTS	MA MA MA	VISUAL MEASUREMENT ELECT. & MECH TESTS	100% SAMPLE -DO-	- MANUFR'S DRG. . MANUF'S SPEC./ RELEVANT IS	NO VISUAL DEFECTS (FREE FROM BURS) MANUFR'S DRG. RELEVANT IS	LOG BOOK -DO- SUPPLIER'S TC	3 3 3	- -	- 2 2	FOR MV MOTOR INSULATION/VARNISH THICKNESS SHALL BE MORE THAN THE BURS HEIGHT
1.9	CONDUCTORS	1. SURFACE FINISH 2.ELECT. PROP. & MECH. PROP	MA MA	VISUAL ELECT. & MECH.TEST	100% SAMPLES	- RELEVANT IS/ BS OR OTHER STANDARDS	FREE FROM VISUAL DEFECTS RELEVANT IS/ BS OR OTHER STANDARDS	LOG BOOK SUPPLIERS TC & VENDOR'S INSPN. REPORTS	3* 3	- -	2* 2	* MOTOR MANUFACTURER TO CONDUCT VISUAL CHECK FOR SURFACE FINISH ON RANDOM BASIS (10% SAMPLE) AT HIS WORKS AND MAINTAIN RECORD FOR VERIFICATION BY BHEL/CUSTOMER.
BHEL			PARTICULARS			BIDDER/VENDOR						
			NAME									
			SIGNATURE									
			DATE			BIDDER'S/VENDORS COMPANY SEAL						



QUALITY PLAN

SHEET 4 OF 9

CUSTOMER TSPGCL

PROJECT 1 X 800 MW KOTHAGUDEM TPS

SPECIFICATION :

BIDDER/ VENDOR :

QUALITY PLAN NUMBER PED-506-00-Q-007, REV-03

NUMBER :

SYSTEM

ITEM: AC ELECT. MOTORS 55 KW & ABOVE (LV & MV)

SECTION

VOLUME III

SL. NO.	COMPONENT/OPERATION	CHARACTERISTIC CHECK	CAT.	TYPE/METHOD OF CHECK	EXTENT OF CHECK	REFERENCE DOCUMENT	ACCEPTANCE NORM	FORMAT OF RECORD	AGENCY			REMARKS
									P	W	V	
1	2	3	4	5	6	7	8	9	10			11
1.10	BEARINGS	3.DIMENSIONS	MA	MEASUREMENT	-DO-	-DO-	-DO-	Log Book	3	-	2	
		1.MAKE & TYPE	MA	VISUAL	100%	MANFR'S DRG./ APPROVED DATASHEET	MANFR'S DRG./ APPROVED DATASHEET	-DO-	3	-	2	
		2.DIMENSIONS	MA	MEASUREMENT	SAMPLE	BHEL DATA SHEET	BHEL DATA SHEET BEARING MANUF'S CATALOGUES	-DO-	3	-	2	
1.11	SLIP RING (WHEREVER APPLICABLE)	3.SURFACE FINISH	MA	VISUAL	100%	-	FREE FROM VISUAL DEFECTS	-DO-	3	-	2	
		1.SURFACE COND.	MA	VISUAL	100%	-	-DO-	-DO-	3	-	-	
		2.DIMENSIONS	MA	MEASUREMENT	SAMPLE	MANUF'S DRG	MANUF'S DRG	-DO-	3	-	-	
		3.TEMP.WITH-STAND CAPACITY	MA	ELECT.TEST	-DO-	MANUF'S SPEC./ BHEL SPEC.	MANUF'S SPEC./ BHEL SPEC.	-DO-	3	-	2	
1.12	OIL SEALS & GASKETS	4.HV/IR	MA	-DO-	100%	-DO-	-DO-	-DO-	3	-	2	
		1.MATERIAL OF GASKET	MA	VISUAL	100%	MANUF'S DRG/SPECS	MANUF'S DRG./ SPECS.	-DO-	3	-	-	
		2.SURFACE COND.	MA	VISUAL	100%	-	FREE FROM VISUAL DEFECTS	-DO-	3	-	-	
		3.DIMENSIONS	MA	MEASUREMENT	SAMPLE	MANUF'S DRG	MANUF'S DRG	-DO-	3	-	-	
BHEL			PARTICULARS			BIDDER/VENDOR						
			NAME									
			SIGNATURE									
			DATE									BIDDER'S/VENDORS COMPANY SEAL



QUALITY PLAN

SHEET 5 OF 9

CUSTOMER TSPGCL PROJECT 1 X 800 MW KOTHAGUDEM TPS
TITLE

SPECIFICATION :
NUMBER :

BIDDER/ : QUALITY PLAN
VENDOR : NUMBER PED-506-00-Q-007, REV-03
SYSTEM ITEM: AC ELECT. MOTORS 55 KW & ABOVE (LV & MV)

SPECIFICATION :
TITLE SECTION VOLUME III

SL. NO.	COMPONENT/OPERATION	CHARACTERISTIC CHECK	CAT.	TYPE/METHOD OF CHECK	EXTENT OF CHECK	REFERENCE DOCUMENT	ACCEPTANCE NORM	FORMAT OF RECORD	AGENCY			REMARKS
									P	W	V	
1	2	3	4	5	6	7	8	9	10			11
2.0	IN PROCESS											
2.1	STATOR FRAME WELDING (IN CASE OF FABRICATED STATOR)	1.WORKMANSHIP & CLEANNESS	MA	VISUAL	100%	-DO-	GOOD FINISH	LOG BOOK	3/2	2	-	
		2.DIMENSIONS	MA	MEASUREMENT	-DO-	MANUF'S DRG	MANUF'S DRG	-DO-	2	-	-	
2.2	MACHINING	1.FINISH	MA	VISUAL	100%	-DO-	GOOD FINISH	LOG BOOK	2	-	-	
		2.DIMENSIONS	MA	MEASUREMENT	-DO-	MANUF'S DRG	MANUF'S DRG	-DO-	2	-	-	
		3.SHAFT SURFACE FLOWS	MA	PT	-DO-	RELEVENT SPEC./ ASTM-E165	MANUFR'S SPEC./ BHEL SPEC./	-DO-	2	-	1	
2.3	PAINTING	1.SURFACE PREPARATION	MA	VISUAL	100%	MANFR'S SPEC./BHEL SPEC./ RELEVANT STAND	BHEL SPEC. SAME AS COL.7	LOG BOOK	2	-	-	
		2.PAINT THICKNESS (BOTH PRIMER & FINISH COAT)	MA	MEASUREMENT BY ELCOMETER	SAMPLE	-DO-	-DO-	-DO-	2	-	-	
		3.SHADE	MA	VISUAL	-DO-	-DO-	-DO-	Log Book	2	-	-	
		4.ADHESION	MA	CROSS CUTTING & TAPE TEST	-DO-	-DO-	-DO-	Log Book	2	-	-	
BHEL			PARTICULARS		BIDDER/VENDOR							
			NAME									
			SIGNATURE									
			DATE					BIDDER'S/VENDORS COMPANY SEAL				



QUALITY PLAN

SHEET 6 OF 9

CUSTOMER TSPGCL			PROJECT 1 X 800 MW KOTHAGUDEM TPS			SPECIFICATION :							
BIDDER/ VENDOR :			TITLE			NUMBER :							
SYSTEM			QUALITY PLAN NUMBER PED-506-00-Q-007, REV-03			SPECIFICATION :							
ITEM: AC ELECT. MOTORS 55 KW & ABOVE (LV & MV)			SECTION			VOLUME III							
SL. NO.	COMPONENT/OPERATION	CHARACTERISTIC CHECK	CAT.	TYPE/ METHOD OF CHECK	EXTENT OF CHECK	REFERENCE DOCUMENT	ACCEPTANCE NORM	FORMAT OF RECORD	AGENCY			REMARKS	
									P	W	V		
1	2	3	4	5	6	7	8	9	10			11	
2.4	SHEET STACKING	1.COMPLETENESS	MA	MEASUREMENT	SAMPLE	MANUFR'S SPEC.	MANUFR'S SPEC.	Log Book	2	-	-	(FOR MOTORS OF 2MW AND ABOVE) * ON 10% RANDOM SAMPLE	
		2.COMPRESSION & TIGHTENING	MA	MEASUREMENT	100%	-DO-	-DO-	Log Book	2	-	-		
		3.CORE LOSS & HOTSPOT	MA	ELECT.TEST	-DO-	-DO-	-DO-	Log Book	2	1*	1		
2.5	WINDING	1.COMPLETENESS	CR	VISUAL	100%	MANUFR'S SPEC./BHEL SPEC.	MANUFR'S SPEC./BHEL SPEC.	Log Book	2	-	-		
		2.CLEANLINESS	CR	-DO-	-DO-	-DO-	-DO-	Log Book	2	-	-		
		3.IR-HV-IR	CR	ELECT. TEST	-DO-	-DO-	-DO-	Log Book	2	-	1		
		4.RESISTANCE	CR	-DO-	-DO-	-DO-	-DO-	Log Book	2	-	1		
2.6	IMPREGNATION	5.INTERTURN INSULATION	CR	-DO-	-DO-	-DO-	-DO-	Log Book	2	-	-		
		6.SURGE WITH STAND AND TAN. DELTA TEST	CR	-DO-	-DO-	-DO-	-DO-	Log Book	2	-	1		FOR MV MOTOR
		1.VISCOSCITY	MA	PHY. TEST	AT STARTING	-DO-	-DO-	Log Book	2	-	-		
		2.TEMP. PRESSURE VACCUM	MA	PROCESS CHECK	CONTINUOUS	-DO-	-DO-	Log Book	2	-	-		
2.6	IMPREGNATION	3.NO. OF DIPS	MA	-DO-	-DO-	-DO-	-DO-	Log Book	2	-	1	THREE DIPS TO BE GIVEN	

BHEL			PARTICULARS			BIDDER/VENDOR					
			NAME								
			SIGNATURE								
			DATE						BIDDER'S/VENDORS COMPANY SEAL		

		QUALITY PLAN			CUSTOMER TSPGCL		PROJECT 1 X 800 MW KOTHAGUDEM TPS		SPECIFICATION :			
					BIDDER/ VENDOR :		QUALITY PLAN NUMBER PED-506-00-Q-007, REV-03		NUMBER :			
SHEET 7 OF 9		SYSTEM		ITEM: AC ELECT. MOTORS 55 KW & ABOVE (LV & MV)		SECTION		VOLUME III				
SL. NO.	COMPONENT/OPERATION	CHARACTERISTIC CHECK	CAT.	TYPE/METHOD OF CHECK	EXTENT OF CHECK	REFERENCE DOCUMENT	ACCEPTANCE NORM	FORMAT OF RECORD	AGENCY			REMARKS
									P	W	V	
1	2	3	4	5	6	7	8	9	10			11
2.7	COMPLETE STATOR ASSEMBLY	4.DURATION	MA	-DO-	-DO-	-DO-	-DO-	Log Book	2	-	1	VERIFICATION FOR MV MOTOR ONLY
2.8	BRAZING/COMPRESSION JOINT	1.COMPACTNESS & CLEANLINESS	MA	VISUAL	100%	-DO-	-DO-	Log Book	2	-	-	
2.9	COMPLETE ROTOR ASSEMBLY	1.COMPLETENESS	CR	-DO-	-DO-	-DO-	-DO-	Log Book	2	-	-	
		2.SOUNDNESS	CR	MALLET TEST & UT	-DO-	-DO-	-DO-	Log Book	2		1	
		3.HV	MA	ELECT. TEST	-DO-	-DO-	-DO-	Log Book	2		1	
2.10	ASSEMBLY	1.RESIDUAL UNBALANCE	CR	DYN. BALANCE	-DO-	MFG SPEC./ ISO 1940	MFG. DWG.	Log Book	2		1	
		2.SOUNDNESS OF DIE CASTING	CR	ELECT. (GROWLER TEST)	-DO-	MFG. SPEC.	MFG. SPEC.	Log Book	2		1	
2.10	ASSEMBLY	1.ALIGNMENT	MA	MEAS.	-DO-	-DO-	-DO-	Log Book	2	-	-	
		2.WORKMANSHIP	MA	VISUAL	-DO-	-DO-	-DO-	Log Book	2	-	-	
		3.AXIAL PLAY	MA	MEAS.	-DO-	-DO-	-DO-	Log Book	2	-	1	
		4.DIMENSIONS	MA	-DO-	-DO-	MFG.DRG./ MFG SPEC.	MFG. DRG/ RELEVANT IS	Log Book	2	-	-	
		5.CORRECTNESS, COMPLETENESS TERMINATIONS/ MARKING/ COLOUR CODE	MA	VISUAL	100%	MFG SPEC. RELEVANT IS	MFG SPEC. RELEVANT IS	Log Book	2	-	-	
		6. RTD, BTD & SPACE HEATER MOUNTING.	MA	VISUAL	100%	MFG SPEC. RELEVANT IS	MFG SPEC. RELEVANT IS	Log Book	2		1	
BHEL			PARTICULARS		BIDDER/VENDOR							
			NAME									
			SIGNATURE									
			DATE		BIDDER'S/VENDORS COMPANY SEAL							



QUALITY PLAN

SHEET 8 OF 9

CUSTOMER TSPGCL

PROJECT 1 X 800 MW KOTHAGUDEM TPS

SPECIFICATION :

BIDDER/ VENDOR :

QUALITY PLAN

NUMBER :

SYSTEM

NUMBER PED-506-00-Q-007, REV-03

TITLE

ITEM: AC ELECT. MOTORS 55 KW & ABOVE (LV & MV)

SECTION

VOLUME III

SL. NO.	COMPONENT/OPERATION	CHARACTERISTIC CHECK	CAT.	TYPE/METHOD OF CHECK	EXTENT OF CHECK	REFERENCE DOCUMENT	ACCEPTANCE NORM	FORMAT OF RECORD	AGENCY			REMARKS
									P	W	V	
1	2	3	4	5	6	7	8	9	10			11
3.0	TESTS	1. TYPE TESTS INCLUDING SPECIAL TESTS AS PER BHEL SPEC.	MA	ELECT. TEST	1/TYPE/SIZE	IS-325/ BHEL SPEC./ DATA SHEET	IS-325/ BHEL SPEC./ DATA SHEET	TEST REPORT	2	1*	1	* NOTE - 1
		2. ROUTINE TESTS INCLUDING SPECIAL TEST AS PER BHEL SPEC.	MA	-DO-	100%	-DO-	-DO-	-DO-	2	1 ^s	1	^s NOTE - 2
		3. VIBRATION & NOISE LEVEL	MA	-DO-	100%	IS-12075 & IS-12065	IS-12075 & IS-12065	-DO-	2	1 ^s	1	^s NOTE - 2
		4. OVERALL DIMENSIONS AND ORIENTATION	MA	MEASUREMENT & VISUAL	100%	APPROVED DRG/DATA SHEET	APPROVED DRG/DATA SHEET & RELEVANT IS	INSPC. REPORT	2	1	-	
		5. DEGREE OF PROTECTION	MA	ELECT. & MECH. TEST	1/TYPE/ SIZE	RELEVANT IS	BHEL SPEC. AND DATA SHEET	TC	2	-	1	TC FROM AN INDEPENDENT LABORATORY, REFER NOTE-3
		6. MEASUREMENT OF RESISTANCE OF RTD & BTD	MA	-DO-	100%	-DO-	-DO-	-DO-	2	1 ^s	1	^s NOTE - 2
		7. MEASUREMENT OF RESISTANCE, IR OF SPACE HEATER	MA	-DO-	100%	-DO-	-DO-	-DO-	2	1 ^s	1	^s NOTE - 2
		8. NAMEPLATE DETAILS	MA	VISUAL	100%	IS-325 & DATA SHEET	IS-325 & DATA SHEET	INSPC. REPORT	2	1 ^s	1	^s NOTE - 2
		9. EXPLOSION FLAME PROOF NESS (IF SPECIFIED)	MA	EXPLOSION FLAME PROOF TEST	1/TYPE	IS-3682 IS-8239 IS-8240	IS-3682 IS-8239 IS-8240	TC	2	-	1	TC FROM AN INDEPENDENT LABORATORY, REFER NOTE-3
		10. PAINT SHADE, THICKNESS & FINISH	MA	VISUAL & MEASUREMENT BY ELKOMETER	SAMPLE	BHEL SPEC. & DATA SHEET	BHEL SPEC. & DATA SHEET	TC	2	1 ^s	1	SAMPLING PLAN TO BE DECIDED BY INSPECTION AGENCY ^s NOTE - 2
BHEL			PARTICULARS			BIDDER/VENDOR						
			NAME									
			SIGNATURE									
			DATE						BIDDER/S/VENDORS COMPANY SEAL			



QUALITY PLAN

SHEET 9 OF 9

CUSTOMER TSPGCL

PROJECT 1 X 800 MW KOTHAGUDEM TPS

SPECIFICATION :

BIDDER/ VENDOR :

QUALITY PLAN NUMBER PED-506-00-Q-007, REV-03

NUMBER :

SYSTEM

ITEM: AC ELECT. MOTORS 55 KW & ABOVE (LV & MV)

SPECIFICATION : TITLE SECTION VOLUME III

SL. NO.	COMPONENT/OPERATION	CHARACTERISTIC CHECK	CAT.	TYPE/METHOD OF CHECK	EXTENT OF CHECK	REFERENCE DOCUMENT	ACCEPTANCE NORM	FORMAT OF RECORD	AGENCY			REMARKS
									P	W	V	
1	2	3	4	5	6	7	8	9	10			11

NOTES:

- 1 DEPENDING UPON THE SIZE AND CRITICALLY, WITNESSING BY BHEL SHALL BE DECIDED.
- 2 ROUTINE TESTS ON 100% MOTORS SHALL BE DONE BY THE VENDOR. HOWEVER, BHEL SHALL WITNESS ROUTINE TESTS ON RANDOM SAMPLES. THE SAMPLING PLAN SHALL BE MUTUALLY AGREED UPON.
- 3 IN CASE TEST CERTIFICATES FOR THESE TESTS ON SIMILAR TYPE, SIZE AND DESIGN OF MOTOR FROM INDEPENDENT LABORATORY ARE AVAILABLE, THESE TEST MAY NOT BE REPEATED.
- 4 WHEREVER CUSTOMER IS INVOLVED IN INSPECTION, AGENCY (1) SHALL MEAN BHEL AND CUSTOMERS BOTH TOGETHER.

Legends for Inspection agency

1. BHEL/CUSTOMER
2. VENDOR (MOTOR MANUFACTURER)
3. SUB-VENDOR (RAW MATERIAL/COMPONENTS SUPPLIER)

- P. PERFORM
W. WITNESS
V. VERIFY

BHEL	PARTICULARS	BIDDER/VENDOR	
	NAME		
	SIGNATURE		
	DATE		BIDDER'S/VENDORS COMPANY SEAL

		QUALITY PLAN			CUSTOMER TSPGCL		PROJECT 1 X 800 MW KOTHAGUDEM TPS		SPECIFICATION :			
					BIDDER/ VENDOR :		TITLE		NUMBER :			
		SHEET 1 OF 2			SYSTEM		QUALITY PLAN NUMBER PED-506-00-Q-006, REV-01		SPECIFICATION TITLE			
							ITEM AC ELECT. MOTORS BELOW 55KW (LV)		SECTION		VOLUME III	
SL. NO.	COMPONENT/OPERATION	CHARACTERISTICS CHECK	CAT.	TYPE/ METHOD OF CHECK	EXTENT OF CHECK	REFERENCE DOCUMENT	ACCEPTANCE NORM	FORMAT OF RECORD	AGENCY			REMARKS
									P	W	V	
1	2	3	4	5	6	7	8	9	10			11
1.0	ASSEMBLY	1.WORKMANSHIP	MA	VISUAL	100%	MANUF'S SPEC	MANUF'S SPEC	-DO-	2	-	-	
		2.DIMENSIONS	MA	-DO-	-DO-	MFG. DRG./ MFG. SPEC.	MFG. DRG./ MFG. SPEC.	-DO-	2	-	-	
		3.CORRECTNESS COMPLETENESS TERMINATIONS/ MARKING/COLOUR CODE	MA	VISUAL	100%	MFG.SPEC./ RELEVANT IS	MFG.SPEC. RELEVANT IS	-DO-	2	-	-	
2.0	PAINTING	1.SHADE	MA	VISUAL	SAMPLE	MANUF'R'S SPEC/BHEL SPEC./RELEVANT STANDARD	BHEL SPEC. SAME AS COL.7	LOG BOOK	2	-	-	
3.0	TESTS	1.ROUTINE TEST INCLUDING SPECIAL TEST AS PER BHEL SPEC.	MA	-DO-	100%	IS-325/ BHEL SPEC./ DATA SHEET	SAME AS COL.7	TEST REPORT	2	1	-	NOTE -1 & NOTE-3
		2.OVERALL DIMENSIONS & ORIENTATION	MA	MEASUREMENT & VISUAL	100%	APPROVED DRG/DATA SHEET	APPROVED DRG/DATA SHEET & RELEVANT IS	INSPN. REPORT	2	1	-	NOTE -1 & NOTE-3
BHEL			PARTICULARS			BIDDER/VENDOR						
			NAME									
			SIGNATURE									
					CUSTOMER TSPGCL		PROJECT 1 X 800 MW KOTHAGUDEM TPS		SPECIFICATION :			



QUALITY PLAN

TITLE

NUMBER :

BIDDER/ :
VENDOR

QUALITY PLAN
NUMBER PED-506-00-Q-006, REV-01

SPECIFICATION :
TITLE :

SHEET 2 OF 2

SYSTEM

ITEM AC ELECT. MOTORS BELOW 55KW (LV)

SECTION VOLUME III

SL. NO.	COMPONENT/OPERATION	CHARACTERISTICS CHECK	CAT.	TYPE/METHOD OF CHECK	EXTENT OF CHECK	REFERENCE DOCUMENT	ACCEPTANCE NORM	FORMAT OF RECORD	AGENCY			REMARKS
									P	W	V	
1	2	3	4	5	6	7	8	9	10			11
		3.NAMEPLATE DETAILS	MA	VISUAL	100%	IS-325 & DATA SHEET	IS-325 & DATA SHEET	INSPN. REPORT	2	1	-	
<p>NOTES:</p> <p>1 ROUTINE TESTS ON 100% MOTORS SHALL BE DONE BY THE VENDOR. HOWEVER, BHEL SHALL WITNESS ROUTINE TESTS ON RANDOM SAMPLES. THE SAMPLING PLAN SHALL BE MUTUALLY AGREED UPON</p> <p>2 WHERE EVER CUSTOMER IS INVOLVED IN INSPECTION, (1) SHALL MEAN BHEL AND CUSTOMERS BOTH TOGETHER.</p> <p>3 FOR EXHAUST/VENTILATION FAN MOTORS OF RATING UPTO 1.5KW , ONLY ROUTINE TEST CERTIFICATES SHALL BE FURNISHED FOR SCRUTINY.</p> <p><u>Legends for Inspection agency</u></p> <p>1. BHEL/CUSTOMER 2. VENDOR (MOTOR MANUFACTURER) 3. SUB-VENDOR (RAW MATERIAL/COMPONENTS SUPPLIER)</p> <p>P. PERFORM W. WITNESS V. VERIFY</p>												
BHEL			PARTICULARS		BIDDER/VENDOR							
			NAME									
			SIGNATURE									
			DATE					BIDDER'S/VENDORS COMPANY SEAL				



**TITLE : TECHNICAL SPECIFICATION
FOR
DEBRIS FILTER (DF)**

SPEC. NO. PE-TS- 410-165-N001

VOLUME : IIB

SECTION : D

REV. NO. 0

**DATE :
18.06.2015**

SHEET 1 of 1

**SECTION D3
STANDARD TECHNICAL SPECIFICATION
FOR
C&I SYSTEMS**



Technical specification for
CONTROL & INSTRUMENTATION

1X800 MW KOTHAGUDEM

SPEC NO.: **PE-TS-410-145-I**

VOLUME

SECTION

REV. NO. 00

DATE : 27.05.2015

SHEET OF

Instrumentation Quality Plan



STANDARD CHECK LIST FOR C&I INSTRUMENTS (for Maux Pkgs)

CHECK LIST FOR PRESSURE SWITCH

Sl. No.	Test / Checks	Quantum of check	Reference Doc. / Acceptance Norms	Agency **			Remarks	
				M	C	B		
1	CHECK FOR	SEE NOTE-1 BELOW	APPROVED SPEC./ DATA SHEETS	P	V	V		
	1.1 MODEL NO/TAG NO							
	1.2 RANGE							
	1.3 END CONN							
	1.4 NO. OF CONTACT							
2	CALIBRATION				P	V	V	
	2.1 REPEATABILITY							
	2.2 SET POINT ADJUSTMENT							
	2.3 DIFFERENTIAL							
3	OVER PR & LEAK TEST				P	V	V	
4	ELECT. INSULATION/HV TEST	ONE	P	V	V			
5	REVIEW OF TC FOR MATERIALS OF	FOR LOT		V	V	V		
	5.1 SENSOR							
	5.2 MOVEMENT							
	5.3 PROCESS CONNECTION							
	5.4 HOUSING							
6	REVIEW OF TC FOR DEGREE OF PROTECTION	TYPE TEST	V	V	V			
7	REVIEW OF TC OF MICROSWITCH	FOR LOT	V	V	V			

** M = Manufacturer / Sub-contractor, C = Contractor / Nominated Inspecting Agency, B = BHEL, P = Perform, W = Witness, V = Verification

Note :

- Quantum of check shall be as below :
100 % - By Manufacturer
- Manufacturer to carry out ROUTINE TEST on 100 %.
- Contractor to provide compliance certificate for tests/checks verified by contractor and the same alongwith test certificates to be verified by BHEL



STANDARD CHECK LIST FOR C&I INSTRUMENTS (for Maux Pkgs)

CHECK LIST FOR TRANSMITTER

Sl. No.	Test / Checks	Quantum of check	Reference Doc. / Acceptance Norms	Agency **			Remarks
				M	C	B	
1	CHECKS FOR	SEE NOTE-1 BELOW	APPROVED SPEC./ DATA SHEETS	P	W	V	
	VISUAL.						
	MODEL/TAG No						
2	PROCESS CONNECTION			P	W	V	
3	ACCURACY			P	W	V	
4	REPEATABILITY			P	W	V	
5	HYSTERESIS	P		W	V		
6	EFFECT OF TEMP VARIATION ON ACCURACY	P		W	V		
7	SPAN / ZERO ADJUSTMENT	ONE / TYPE		P	W	V	
8	EFFECT OF SUPPLY VOLTAGE VARIATION			P	W	V	
9	EFFECT OF LOADING (500 OHM METERS)			P	W	V	
10	HIGH PRESSURE TEST	SEE NOTE-1 BELOW		P	W	V	
11	BURN-IN TEST	ONE / TYPE		P	W	V	
12	DEGREE OF PROTECTION		P	W	V		
13	ACCESSORIES AS APPLICABLE	SEE NOTE-1 BELOW	V	V	V		

Legend :

** M = Manufacturer / Sub-contractor, C = Contractor / Nominated Inspecting Agency, B = BHEL, P = Perform, W = Witness, V = Verification

Note :

- Quantum of check shall be as below :
100 % - By Manufacturer
- Manufacturer to maintain calibrated instrument having better accuracy than the item under test. Inspecting engineer shall check the same.
- When material correlation are not available manufacturer's compliance to be provided.
- Contractor to provide compliance certificate for tests/checks verified by contractor and submit the same alongwith test certificates to be verified by BHEL.



STANDARD CHECK LIST FOR C&I INSTRUMENTS (for Maux Pkgs)

CHECK LIST FOR PRESSURE & DP GAUGE

Sl. No.	Test / Checks	Quantum of check	Reference Doc. / Acceptance Norms	Agency **			Remarks	
				M	C	B		
1	CHECK FOR	SEE NOTE-1 BELOW	APPROVED SPEC./ DATA SHEETS	P	W	V		
	SENSOR TYPE							
	DIAL SIZE							
	MODEL NO/TAG NO							
	RANGE/SCALE							
	SWITCH CONTACT RATING & NOS.							
	END CONNECTION							
2	CALIBRATION	ONE	APPROVED SPEC./ DATA SHEETS	P	W	V		
	ACCURACY							
	REPEATABILITY							
	SET POINT ADJUSTMENT							
3	OVER PRESSURE & LEAK TEST			P	W	V		
4	OPERATION OF PRESSURE. RELIEF DEVICE			P	W	V		
5	REVIEW OF TC FOR	FOR LOT	APPROVED SPEC./ DATA SHEETS	V	V	V		
	MATERIALS OF SENSOR							
	MOVEMENT							
	PROCESS CONNECTION							
6	REVIEW OF TC FOR DEGREE OF PROTECTION	TYPE TEST			V	V	V	
7	ACCESSORIES AS APPLICABLE	SEE NOTE-1 BELOW			V	V	V	

Legend :

** M = Manufacturer / Sub-contractor, C = Contractor / Nominated Inspecting Agency, B = BHEL, P = Perform, W = Witness, V = Verification

Note :

- Quantum of check shall be as below :
100 % - By Manufacturer
- Manufacturer to maintain calibrated instrument having better accuracy than the item under test. Inspecting engineer shall check the same.
- Manufacturer to carry out ROUTINE TEST on 100 %.
- When material correlation is not available, MFR's compliance to be provided
- Contractor to provide compliance certificate for tests/checks verified by contractor and submit the same alongwith test certificates to be verified by BHEL.



STANDARD CHECK LIST FOR C&I INSTRUMENTS (for Maux Pkgs)

CHECK LIST FOR ANNUNCIATORS

Sl. No.	Test / Checks	Quantum of check	Reference Doc. / Acceptance Norms	Agency **			Remarks
				M	C	B	
1	CHECK FOR	SEE NOTE-1 BELOW	APPROVED SPEC./ DATA SHEETS	P	W	V	
	TYPE/ MODEL						
	DIMENSIONS OF HARDWARE						
	MODULARITY						
	SEQUENCE						
	FACIA DETAILS						
2	FUNCTIONAL TEST	100%		P	W	V	
3	IMMUNE TO STEP VARIATIONS IN THE POWER SUPPLY	SEE NOTE-1 BELOW		P	W	V	
4	DEGREE OF PROTECTION FOR ENCLOSURE	TYPE TEST		P	W	V	
5	I/R CHECK	SEE NOTE-1 BELOW		P	W	V	
6	RESPONSE			P	W	V	

Legend :

** M = Manufacturer / Sub-contractor, C = Contractor / Nominated Inspecting Agency, B = BHEL, P = Perform, W = Witness, V = Verification

Note :

- Quantum of check shall be as below :
100 % - By Manufacturer
- Manufacturer to maintain calibrated instrument having better accuracy than the item under test. Inspecting engineer shall check the same.
- Manufacturer to carry out ROUTINE TEST on 100 %.
- Contractor to provide compliance certificate for tests/checks verified by contractor and submit the same alongwith test certificates to be verified by BHEL.



Technical specification for
CONTROL & INSTRUMENTATION

1X800 MW KOTHAGUDEM

SPEC NO.: **PE-TS-410-145-I**

VOLUME

SECTION

REV. NO. 00

DATE : 27.05.2015

SHEET OF

LCP Quality Plan



PEM :: C&I

STANDARD QUALITY PLAN FOR LOCAL CONTROL PANEL

STD QUALITY PLAN NO.: PE-QP-999-145-1056

VOLUME IIB

SECTION D

REV. NO. 01 DATE: 22-02-2008

SHEET 1 OF 7

Sl. No.	Component / operation	Characteristics Checked	* Category	Type/Method of Check	Extent of Check	Reference documents	Acceptance Norms	Format of Records	Agency \$				Remarks	
									P	W	V			
1.0	INCOMING Sheet Steel (CRCA & HR)	1. Chemical Composition	MA	Chemical analysis	Sample	Relevant standard	Relevant standard	Test Certificate	3	---	---	2		
		2. Bend Test	CR	Mech. test	Sample	Relevant standard	Relevant standard	Log Book	2	---	---	---		
		3. Surface finish	MA	Visual	100%	100%	Factory Standard / Sample	Factory Standard / Sample	Log Book	2	---	---	---	
		4. Waviness	MA	Visual	100%	100%	Factory Standard	No Waviness	Log Book	2	---	---	---	
		5. Thickness	MA	Measurement	100%	100%	BHEL Spec.	BHEL Spec.	Log Book	2	---	---	---	
		6. Mill marking	MA	Visual	100%	100%	Factory Standard	Factory Standard	Log Book	2	---	---	1	
2.0	Flats / Angles / Channels	1. Dimensions	MA	Measurement	Sample	Relevant standard	Relevant standard	Log Book	2	---	---	---		
		2. Surface Defects	MA	Visual	100%	100%	Factory Standard / Sample	Factory Standard / Sample	Log Book	2	---	---	---	
		3. Straightness	MA	Measurement	100%	100%	Factory Std.	Factory Std.	Log Book	2	---	---	---	
		4. Mill marking	MA	Visual	100%	100%	Relevant standard	Relevant standard	Log Book	2	---	---	1	
3.0	Cables / Wires	1. Visual / Surface defects	MA	Visual	100%	BHEL Spec. and Relevant standard	BHEL Spec. and Relevant standard	Log Book	2	---	---	---		
		2. IR and HV	MA	Electrical	100%	BHEL Spec. and Relevant standard	BHEL Spec. and Relevant standard	Log Book	2	---	---	---		

LEGEND: * CR - Critical characteristics
MA - Major characteristics
MI - Minor characteristics

\$ P - Agency Performing the Test.
W - Agency Witnessing the Test.
V - Agency Verifying the Test.

1 - BHEL
2 - Vendor
3 - Sub-vendor



PEM :: C&I

STANDARD QUALITY PLAN FOR LOCAL CONTROL PANEL

STD QUALITY PLAN NO.: **PE-QP-999-145-1056**

VOLUME IIB

SECTION D

REV. NO. **01** DATE: **22-02-2008**

SHEET 2 OF 7

Sl. No.	Component / operation	Characteristics Checked	* Category	Type/Method of Check	Extent of Check	Reference documents	Acceptance Norms	Format of Records	Agency \$			Remarks
									P	W	V	
		3. Conductor a) Resistance b) Size c) Sheet colour	MA MA MA	Electrical Measurement Visual	100% 100% 100%	BHEL Spec. and Relevant standard	BHEL Spec. and Relevant standard	Log Book	2	---	---	
		4. Type / Routine Test Certificates	MA	Verification	100%	BHEL Spec. and Relevant standard	BHEL Spec. and Relevant standard	Log Book	3	---	2	
4.0	Electrical Components like Annunciator Transformers Lamps Switches PBs Contactors Relays Timers Space Heaters Thermostat Indicating meters etc.	1. Verification at make and Type 2. Verification of Test Certificates 3. Operation / Functional check 4. I.R. 5. H.V. 6. Calibration 7. Pick up / Drop off Voltage	CR CR CR MA MA MA MA	Visual Scrutiny of Type / Routine T.Cs. Electrical Electrical Electrical Electrical	Sample 100% Sample+ 100% 100% 100% 100% 100%	BHEL Spec. and BOM Relevant standard Relevant standard & Catalogue Relevant standard & Catalogue Relevant standard & Catalogue Relevant standard & Catalogue Relevant standard & Catalogue	BHEL Spec. and BOM Relevant standard Relevant standard & Catalogue Relevant standard & Catalogue Relevant standard & Catalogue Relevant standard & Catalogue Relevant standard & Catalogue	Log Book Log Book Log Book Log Book Log Book Log Book Log Book	2 2 2 2 2 2 2	---	---	+ for relay & contactors only @ for all components except relays & contactors.
									2	---	1	
									2	---	---	

LEGEND: * CR - Critical characteristics
MA - Major characteristics
MI - Minor characteristics

\$ P - Agency Performing the Test.
W - Agency Witnessing the Test.
V - Agency Verifying the Test.

1 - BHEL
2 - Vendor
3 - Sub-vendor



PEM :: C&I

STANDARD QUALITY PLAN FOR LOCAL CONTROL PANEL

STD QUALITY PLAN NO.: PE-QP-999-145-1056

VOLUME IIB

SECTION D

REV. NO. 01 DATE: 22-02-2008

SHEET 3 OF 7

Sl. No.	Component / operation	Characteristics Checked	* Category	Type/Method of Check	Extent of Check	Reference documents	Acceptance Norms	Format of Records	Agency \$			Remarks
									P	W	V	
5.0	Misc. Components like Gaskets, Terminal Blocks etc.	1. Verification of Type / Make 2. Surface defects 3. IR / HV on Terminal Blocks	MA MA MA	Visual Visual Electrical	Sample Sample Sample	BHEL Spec. & Mfrs. Catalogue BHEL Spec. & Mfrs. Catalogue BHEL Spec. & Mfrs. Catalogue	BHEL Spec. & Mfrs. Catalogue BHEL Spec. & Mfrs. Catalogue BHEL Spec. & Mfrs. Catalogue	Log Book Log Book Log Book	2 2 2	--- --- ---	--- --- ---	
6.0	IN PROCESS Blanking / Bending / Forming	1. Dimensions 2. Surface defects after bending	MI MA	Measurement Visual	100% 100%	Approved Mfr. drgs. Factory Standard	Approved Mfr. drgs. Factory Standard	Log Book Log Book	2 2	--- ---	--- ---	
7.0	Nibbling / Punching	1. Cutout Sizes 2. Deburring	MI MA	Measurement Visual	100% 100%	Approved Mfr. drgs. Approved Mfr. drgs.	Approved Mfr. drgs. Approved Mfr. drgs.	Log Book Log Book	2 2	--- ---	--- ---	
8.0	ASSEMBLY Frame Assembly & Sheet fixing	1. Dimensions 2. Alignment 3. Welding Quality 4. Surface defects	MA MA MA MA	Measurement Measurement Visual Visual	100% 100% 100% 100%	Approved drg. / Mfr. Standards Approved drg. / Mfr. Standards Approved drg. / Mfr. Standards Approved drg. / Mfr. Standards	Approved drg. / Mfr. Standards Approved drg. / Mfr. Standards Approved drg. / Mfr. Standards Approved drg. / Mfr. Standards	Log Book Log Book Log Book Log Book	2 2 2 2	--- --- --- ---	2 2 2 2	

LEGEND: * CR - Critical characteristics
MA - Major characteristics
MI - Minor characteristics

\$ P - Agency Performing the Test.
W - Agency Witnessing the Test.
V - Agency Verifying the Test.

1 - BHEL
2 - Vendor
3 - Sub-vendor



PEM :: C&I

STANDARD QUALITY PLAN FOR LOCAL CONTROL PANEL

STD QUALITY PLAN NO.: PE-QP-999-145-1056

VOLUME IIB

SECTION D

REV. NO. 01 DATE: 22-02-2008

SHEET 4 OF 7

Sl. No.	Component / operation	Characteristics Checked	* Category	Type/Method of Check	Extent of Check	Reference documents	Acceptance Norms	Format of Records	Agency \$			Remarks
									P	W	V	
9.0	Pre-treatment and Painting	<ol style="list-style-type: none"> 1. Pretreatment Process 2. Process parameters like bath temp. concentration etc. 3. Dipping / Removal Time 4. Surface quality after every dip 5. Primer after phosphating 6. Putty Application & Rubbing after primer 7. Paint first coat 8. Putty Application and Rubbing after first coat of paint 9. Paint second coat 	MA	Visual	100%	Factory Standard & Relevant standard	Factory Standard & Relevant standard	Log Book	2	---	1	
			MA	Measurement	Periodic	Factory Standard & Relevant standard	Factory Standard & Relevant standard	Log Book	2	---	1	
			MA	Measurement	100%	Factory Standard & Relevant standard	Factory Standard & Relevant standard	Log Book	2	---	1	
			MA	Visual	100%	Factory Standard & Relevant standard	Factory Standard & Relevant standard	Log Book	2	---	1	
			MA	Visual, Thickness	100%	Factory Standard & Relevant standard	Factory Standard & Relevant standard	Log Book	2	---	1	
			MA	Visual	100%	Factory Standard & Relevant standard	Factory Standard & Relevant standard	Log Book	2	---	1	
			MA	Visual, Thickness	100%	Factory Standard & Relevant standard	Factory Standard & Relevant standard	Log Book	2	---	1	
			MA	Visual	100%	Factory Standard & Relevant standard	Factory Standard & Relevant standard	Log Book	2	---	1	
			MA	Visual, Thickness, Scratch test Colour adhesion	100%	Factory Standard & Relevant standard	Factory Standard & Relevant standard	Log Book	2	---	1	

LEGEND: * CR - Critical characteristics
 MA - Major characteristics
 MI - Minor characteristics

\$ P - Agency Performing the Test.
 W - Agency Witnessing the Test.
 V - Agency Verifying the Test.

1 - BHEL
 2 - Vendor
 3 - Sub-vendor



PEM :: C&I

STANDARD QUALITY PLAN FOR LOCAL CONTROL PANEL

STD QUALITY PLAN NO.: PE-QP-999-145-1056

VOLUME IIB

SECTION D

REV. NO. 01 DATE: 22-02-2008

SHEET 5 OF 7

Sl. No.	Component / operation	Characteristics Checked	* Category	Type/Method of Check	Extent of Check	Reference documents	Acceptance Norms	Format of Records	Agency \$			Remarks
									P	W	V	
10.	Panel Wiring	<ol style="list-style-type: none"> Wiring Layout Wiring Termination (Crimped Lugs) Ferrule numbers Colour of wiring Size of Conductor 	MA	Visual	100%	Approved drgs. & Specs.	Approved drgs. & Specs.	Log Book	2	---	---	
			MA	Visual	100%	Approved drgs. & Specs.	Approved drgs. & Specs.	Log Book	2	---	---	
			MA	Visual	100%	Approved drgs. & Specs.	Approved drgs. & Specs.	Log Book	2	---	---	
			MA	Visual	100%	Approved drgs. & Specs.	Approved drgs. & Specs.	Log Book	2	---	1	
			MA	Measurement	100%	Approved drgs. & Specs.	Approved drgs. & Specs.	Log Book	2	---	1	
11.	Component Mounting	<ol style="list-style-type: none"> Correct components Fixing 	MA	Visual	100%	Approved drgs., Specs. & BOM	Approved drgs., Specs. & BOM	Log Book	2	---	---	
			MA	Visual	100%	Approved drgs., Specs. & BOM	Approved drgs., Specs. & BOM	Log Book	2	---	---	
12.	FINAL Final Inspection	<ol style="list-style-type: none"> Workmanship Component layout (neatness, accessibility & safety) Mounting / Proper fixing of all components Components identification Marking / Name plates 	MA	Visual	100%	Factory Standard	Factory Standard	Inspection Report	2	1	1	At Random by BHEL, based on 100 % internal test reports by Mfr.
			MA	Visual	100%	BHEL approved drg. / Spec.	BHEL approved drg. / Spec.	Inspection Report	2	1	1	
			MA	Visual	100%	BHEL approved drg. / Spec.	BHEL approved drg. / Spec.	Inspection Report	2	1	1	

LEGEND: * CR - Critical characteristics
MA - Major characteristics
MI - Minor characteristics

\$ P - Agency Performing the Test.
W - Agency Witnessing the Test.
V - Agency Verifying the Test.

1 - BHEL
2 - Vendor
3 - Sub-vendor



PEM :: C&I

STANDARD QUALITY PLAN FOR LOCAL CONTROL PANEL

STD QUALITY PLAN NO.: **PE-QP-999-145-1056**

VOLUME IIB

SECTION D

REV. NO. **01** DATE: **22-02-2008**

SHEET 6 OF 7

Sl. No.	Component / operation	Characteristics Checked	* Category	Type/Method of Check	Extent of Check	Reference documents	Acceptance Norms	Format of Records	Agency \$			Remarks
									P	W	V	
		5. Dimensions	MA	Measurement	100%	BHEL approved drg. / Spec., BOM	BHEL approved drg. / Spec., BOM	Inspection Report	2	1	1	At Random by BHEL, based on 100 % internal test reports by Mfr.
		6. Door functioning	MA	Functional	100%	BHEL approved drg. / Spec.	BHEL approved drg. / Spec.	Inspection Report	2	1	1	
		7. Paint Shade	CR	Visual	100%	BHEL approved drg. / Spec.	BHEL approved drg. / Spec.	Inspection Report	2	1	1	
		8. Paint Thickness	CR	Measurement	100%	BHEL approved drg. / Spec.	BHEL approved drg. / Spec.	Inspection Report	2	1	1	
		9. Workmanship of Gaskets	MA	Visual	100%	Factory Standard	Factory Standard	Inspection Report	2	1	1	
		10. Wiring Layout	MA	Visual	100%	BHEL approved drg.	BHEL approved drg.	Inspection Report	2	1	1	
		11. Wire Termination	MA	Pulling manually	Sample	-----	Firm termination	Inspection Report	2	1	1	
		12. Continuity	MA	Electrical	100%	-----	Continuity OK	Inspection Report	2	1	1	

LEGEND: * CR - Critical characteristics
 MA - Major characteristics
 MI - Minor characteristics

\$ P - Agency Performing the Test.
 W - Agency Witnessing the Test.
 V - Agency Verifying the Test.

1 - BHEL
 2 - Vendor
 3 - Sub-vendor



PEM :: C&I

STANDARD QUALITY PLAN FOR LOCAL CONTROL PANEL

STD QUALITY PLAN NO.: PE-QP-999-145-1056

VOLUME IIB

SECTION D

REV. NO. 01 DATE: 22-02-2008

SHEET 7 OF 7

Sl. No.	Component / operation	Characteristics Checked	* Category	Type/Method of Check	Extent of Check	Reference documents	Acceptance Norms	Format of Records	Agency \$			Remarks
									P	W	V	
13.	TYPE TEST	Degree of Protection	CR	Mech. Protection	Sample	BHEL approved spec., drg relevant IEC-60947, IEC-60079	BHEL approved spec., drg relevant IEC-60947, IEC-60079	Type Test Certificate	3	---	1	
14	ROUTINE TEST	IR before & after HV Test	CR	Electrical	100%	BHEL approved spec., drg., BOM & relevant standard	BHEL approved spec., drg., BOM & relevant standard	Test Report	2	1	1	
15	FUNCTIONAL TEST	1. Control Logic Operation	CR	Electrical	100%	BHEL approved spec. / drg.	BHEL approved spec. / drg.	Inspection Report	2	1	1	
		2. Instrument Calibratio	CR	Electrical	10%	BHEL approved spec. / drg.	BHEL approved spec. / drg.	Inspection Report	2	1	1	
		3. Temperature rise	CR	Electrical	100%	BHEL approved spec./drg. & relevant standard	BHEL approved spec/drg & relevant standard	Inspection Report	2	1	1	

LEGEND: * CR - Critical characteristics
MA - Major characteristics
MI - Minor characteristics

\$ P - Agency Performing the Test.
W - Agency Witnessing the Test.
V - Agency Verifying the Test.

1 - BHEL
2 - Vendor
3 - Sub-vendor

1X800MW KOTHAGUDEM, TPS, STAGE-VII, UNIT#12- TSGENCO

VOLUME –III

TECHNICAL SPECIFICATION
FOR
DEBRIS FILTER (DF)

Specification No. : PE-TS- 410-165-N001 (REV. 0)



BHARAT HEAVY ELECTRICALS LIMITED
POWER SECTOR
PROJECT ENGINEERING MANAGEMENT
PPEI BLDG., SEC-16A, PLOT NO. 25
NOIDA – 201301 (UP)

	TITLE : TECHNICAL SPECIFICATION	SPEC. NO. PE-TS- 410-165-N001	
	FOR	VOLUME : III	
	DEBRIS FILTER (DF)		
	PREAMBLE	REV. NO. 0	DATE :18.06.2015
		SHEET 1 of 2	

1.0 The tender document contains three (3) volumes. The bidder shall meet the requirements of all the three volumes.

1.1 **Volume -I CONDITIONS OF CONTRACT**

This consists of four parts as below :

Volume - I A : This part contains instructions to bidders for making bids to BHEL.

Volume - I B : This part contains general commercial conditions of the tender and include provision that vendor shall be responsible for the quality of item supplied by their sub-vendors.

Volume - I C : This part contains special conditions of contract.

Volume - I D : This part contains commercial conditions for erection and commissioning site work, as applicable.

1.2 **Volume - II TECHNICAL SPECIFICATIONS**

Technical requirements are stipulated in Volume II which comprises of :

Volume - II A : General Technical Conditions

Volume - II B : Technical specification including drawings, if any

1.2.1 **Volume - II B :**

This volume is sub-divided into following sections:

Section - A : This section outlines the scope of enquiry.

Section - B : This section provides "Project Information"

Section - C : This section indicates technical requirements specific to the contract, not covered in Section-D.

Section - D : This section comprises of standard technical specifications of equipments complete with data sheet A, B & C.

Data sheet-A specifies data and other requirements pertaining to the equipment.

Data sheet - B specifies data to be filled by the bidder (Data Sheet B is contained in Volume - III)

Data sheet - C indicates data documents to be furnished after the award of contract as per agreed schedule by the vendor (as applicable).

	TITLE : TECHNICAL SPECIFICATION	SPEC. NO. PE-TS- 410-165-N001	
	FOR	VOLUME : III	
	DEBRIS FILTER (DF)		
	PREAMBLE	REV. NO. 0	DATE :18.06.2015
		SHEET 2 of 2	

1.2.2 **Volume - III TECHNICAL SCHEDULES**

This volume contains technical schedules and Data Sheets - B, which are to be duly filled by the bidder and the same shall be furnished with the technical bid as per instructions given in Document No.PES-100-901 in Volume-III.

2.0 The requirements mentioned in Section C/Data Sheets-A of Section-D shall prevail and govern in case of conflict between the same and the corresponding requirements mentioned in the descriptive portion in Section -D.

	TITLE : TECHNICAL SPECIFICATION FOR DEBRIS FILTER (DF)	SPEC. NO. PE-TS- 410-165-N001	
		VOLUME : III	
		REV. NO. 0	DATE :18.06.2015
		SHEET 1 OF 1	

INDEX

SECTION	TITLE
A	DETAILS TO BE FURNISHED ALONGWITH BID
A1.	COMPLIANCE CERTIFICATE
A2.	PERFORMANCE GAURANTEE SCHEDULE
A3.	TECHNICAL DEVIATION SCHEDULE
A4.	ELECTRICAL LOAD DATA
A5.	GA DRAWING OF DF
A6.	SCHEDULE OF PRICES (AS PER NIT)
A7.	SCHEDULES OF UNIT PRICES (AS PER NIT)
B	DOCUMENTS TO BE SUBMITTED ON PLACEMENT OF LOI
B1.	DATASHEET – B
B2.	SCHEDULES AS PER LIST.



TITLE :
TECHNICAL SPECIFICATION FOR
DF

SPEC. NO. PE-TS- 410-165-N001

VOLUME III

SECTION

REV. NO. 0

DATE 18.06.2015

SHEET 1 OF 1

SECTION A

SHALL BE FURNISHED ALONGWITH BID

- COMPLIANCE CERTIFICATE
- PERFORMANCE GUARANTEE SCHEDULE
- TECHNICAL DEVIATION SCHEDULE
- ELECTRICAL LOAD DATA
- GA DRG OF DF
- UNIT PRICE SCHEDULE (AS PER NIT)
- TOTAL PRICE SCHEDULE (AS PER NIT).

	TITLE : COMPLIANCE CERTIFICATE FOR DF	SPEC. NO.	SPEC. NO. PE-TS- 410-165-N001
	Project: 1X800MW KOTHAGUEDEM, TPS, STAGE-VII, UNIT#12	DATE:	18.06.2015
		SHEET :	1 OF 2

COMPLIANCE CERTIFICATE

The bidder shall confirm compliance with following by signing/ stamping this compliance certificate and furnish same with the offer.

- a) The scope of supply, technical details, construction features, design parameters etc. shall be as per technical specification & there are no exclusions with regard to same.
- b) There are no other deviations w.r.t. specification other than those furnished in the 'Schedule of Deviations'. Any other deviation, stated or implied, taken elsewhere in the offer stands withdrawn unless specifically brought out in the 'Schedule of Deviations'.
- c) Bidder shall submit QP in the event of order based on the guidelines given in the specification & QP enclosed therein. QP will be subject to BHEL/ Customer/Customer's Consultant approval and customer hold points for inspection/ testing shall be marked in the QP at the contract stage. Inspection/ testing shall be witnessed as per same apart from review of various test certificates/ Inspection records etc. Charges for 3rd party inspection (TUV/ equivalent) for imported components wherever required shall be included by bidder in the base price itself.
- d) Any drawing/ document/ data-sheet/ calculation/ Quality plan/ Instrumentation etc. submitted along with the offer shall be considered for reference only, same shall be subject to BHEL/ Customer/Customer's Consultant approval in the event of order.
- e) The offered materials shall be either equivalent or superior to those specified in the specification. For components where materials are not specified, same shall be suitable for intended duty, all materials shall be subject to approval in the event of order.
- f) The commissioning spares shall be supplied on 'As Required Basis' & prices for same included in the base price itself.
Prices for special tools & tackles, if any, shall also be included in the base price.
Recommended spares for 3 years shall be quoted separately with price indicated separately.
- g) Charges for Installation Checks, Commissioning of equipments, Trial runs and Performance Testing at site shall be included by bidder as per the price format.
- h) All Instruments shall be located in the Instrument Rack (as applicable) to be supplied by bidder.

The instrument rack shall be installed near DF with impulse piping, root valves, fittings, accessories, valve manifolds mounted on gauge racks etc. supplied by bidder accordingly.
- i) The main flanges for DF shall be suitable for the forces and moments as per the specification.
- k) Installation of Cathodic protection along with sacrificial anodes.
- l) The hydrostatic test pressure shall be 1.5 times the design pressure.
- m) All sub - vendors shall be subject to BHEL/ Customer/Customer's Consultant approval in the event of order.
- n) The Performance guarantees of equipments shall stand valid till the satisfactory completion of performance testing & its acceptance by BHEL/ Customer/Customer's Consultant.
- o) The offered DF have been supplied by bidder in the past meeting the customers qualifying criteria of its operation at two sites for minimum period of two years. Any deviation to this criteria shall be suitably highlighted in the deviation schedule.

	TITLE : COMPLIANCE CERTIFICATE FOR DF	SPEC. NO.	SPEC. NO. PE-TS- 410-165-N001
	Project: 1X800MW KOTHAGUDEM, TPS, STAGE-VII, UNIT#12	DATE:	18.06.2015
		SHEET :	2 OF 2

p) The orientation of piping around DF shall be finalised during detailed Engg.

q) Electrical/ C&I :

- All selected motor ratings have minimum 15 % margin over maximum continuous demand of the driven equipment including voltage and frequency variations, temperature rise and other factors.
- Supply of electrical viz. LT power cables, instrumentation and control cables, cable glands, lugs, cable trays etc. shall be as per specification. Their erection shall be done by BHEL
- The junction boxes for termination of DPT/ DPS/ Actuator LS/ solenoid valves/ Ball oversize monitor/ Ball recirculating monitor are included in bidders scope. The instrumentation cable and cabling from instruments/ actuators to junction boxes is also included in bidders scope.
- Valve actuators and controls shall be provided as specified in Data Sheet-A and Project specific requirements as specified in Section C-2 & Section C-3
- Alarms/ annunciations/ instruments shall be finalised during detailed engineering in the event of order which shall be subject to BHEL/ Customer/Customer's Consultant approval and shall be without any commercial implications to BHEL.
- Switch gear panel should have suitable arrangement like bus coupler for providing redundancy to incoming supply feeder.



**TITLE : SCHEDULE OF PERFORMANCE GUARANTEES
FOR
DEBRIS FILTER (DF)**

SPEC. NO. PE-TS- 410-165-N001

VOLUME : III

Sheet 1 of 1 Date- 18.06.2015

S.NO.	DESCRIPTION	UNITS	1X800MW KOTHAGUDEM, TPS, STAGE-VII, UNIT#12
1.	Pressure drop across the Debris Filter (i.e. between inlet & outlet nozzle) under clean condition and Normal flow condition	MWC	

PARTICULARS OF BIDDER/ AUTHORISED REPRESENTATIVE

NAME	DESIGNATION	SIGNATURE	DATE	COMPANY SEAL
-------------	--------------------	------------------	-------------	---------------------

	TITLE * SCHEDULE OF DEVIATIONS () From Conditions of Contract (Volume – 1) () From General Technical Conditions (Volume – II A) () From Technical Specifications (Volume –II B)	SPECIFICATION NO
		VOL III
		SHEET..... OF.....

We the undersigned hereby certify that the above mentioned are the only deviations.

PARTICULARS OF BIDDER / AUTHORISED REPRESENTATIVE				
NAME	DESIGNATION	SIGNATURE	DATE	COMPANY SEAL



TITLE :
TECHNICAL SPECIFICATION FOR
DF

SPEC. NO. PE-TS- 410-165-N001

VOLUME III

SECTION

REV. NO. 0

DATE 18.06.2015

SHEET 1 OF 1

SECTION B

SHALL BE FURNISHED ON PLACEMENT OF LOI

- DATASHEET B
- LIST OF SCHEDULES



TITLE :
TECHNICAL SPECIFICATION FOR
DF

SPEC. NO. PE-TS- 410-165-N001

VOLUME III

SECTION

REV. NO. 0

DATE 18.06.2015

SHEET 1 OF 1

SECTION B1

DATASHEET B



Title
DATA SHEET - B
DEBRIS FILTER
(BACKWASH TYPE)

PECIFICATION NO. PE-TS-999-165-N003
 VOLUME III PART A
 SHEET I OF 9

INSTRUCTION TO BIDDER 1 This data sheet shall be read in conjunction with Specification No. PE-TS-999-165-N003 Section - D, Volume - IIB.
 2. Items which deviate from Specification shall be marked with an asterisk (*)

SL.NO.	ITEM	UNIT	PARTICULARS
1.0	General :		
1.1	Number of Debris Filter being supplied.	Nos.	
1.2	Type & Model (on-line/off-line)		
1.3	Manufacturer		
1.4	Country of origin		
1.5	Capacity, each	M ³ /hr	
1.6	Size		
	a) Inlet connection	mm	
	b) Outlet connection	mm	
1.7	Liquid to be filtered		
2.0	Design :		
2.1	Design Pressure	Bar (g)	
2.2	Design Temperature	°C	
2.3	Flow rate through the Filter :	M ³ /hr	
	a) Normal		
	b) Maximum allowable		
	c) Minimum		
2.4	Design differential pressure for filter section/ screen	bar (g)	
3.0	Guaranteed Performance		
3.1	Pressure drop across the Filter (i.e., between inlet and outlet connections) at normal flow rate.	Bar	
	a) Clean condition		
	b) 50% choked condition		
	c) During flushing operation		
	d) After flushing operation		
3.2	Debris discharge flow during flushing operation.	M ³ /hr	
3.3	Flushing period	Minutes	

Name of Bidder/ Vendor

Revision Number	0	1	2	3	4
Signature of Bidder/ Vendor Authorised Representative					
Date					



Title **DATA SHEET - B
DEBRIS FILTER
(BACKWASH TYPE)**

PECIFICATION NO PE-TS-999-165-N003

VOLUME III PART A

SHEET 2 OF 9

INSTRUCTION TO BIDDER

1. This data sheet shall be read in conjunction with Specification No. PE-TS-999-165-N003 Section - D, Volume - IIB.
2. Items which deviate from Specification shall be marked with an asterisk (*)

SL.NO.	ITEM	UNIT	PARTICULARS
3.4	Minimum pressure differential to cause flushing/ backwashing		
3.5	Maximum size of Particle/ debris which can be safely handled by the filter.		
3.6	Power consumption during flushing	kW	
	a) Flushing Valves(s)		
	b) Debris Discharge Valve		
	c) Debris Extractor		
	d) Water Injector Pump (if any)		
	e) Any other		
	f) Total		
4.0	Operation :		
4.1	Whether automatic flushing/ backwashing operation effected by the following		
	a) Differential pressure		YES/NO
	b) Adjustable timer		YES/NO
	c) Push button		YES/ NO
	d) Any other		YES/NO
4.2	Whether provision for manual flushing / backwashing operation is made in the event of control system failure.		YES/ NO
5.0	Filter Housing Body :		
5.1	Code/ Standard		
5.2	Outer diameter	mm	
5.3	Thickness	mm	
5.4	Materials		
	Housing/ Body		
	Internal Hardware		

Name of Bidder/ Vendor

Revision Number

0

1

2

3

4

Signature of Bidder/ Vendor
Authorised Representative



Title DATA SHEET - B
DEBRIS FILTER
(BACKWASH TYPE)

PECIFICATION NO. PE-TS-999-165-N003
VOLUME III PART A
SHEET 3 OF 9

INSTRUCTION TO BIDDER

1. This data sheet shall be read in conjunction with Specification No. PE-TS-999-165-N003 Section - D, Volume - IIB.
2. Items which deviate from Specification shall be marked with an asterisk (*)

SL.NO.	ITEM	UNIT	PARTICULARS
5.5	External hardware Lining materail (if applicable) and thickness		
5.6	Inspection Hole :		
	a) Type		
	b) Size	mm	
5.7	Whether sight glass is provided		YES/NO
6.0	Filter Section/ Screen Assembly :		
6.1	Perforation/ mesh size	mm	
6.2	Free filter surface area	m ²	
6.2	Total surface area	M ²	
6.4	Thickness	mm	
6.5	Materails :		
	a) Filter section/ scree		
	b) Supporting cage		
	c) Hardware for fixing the filter section/ screen		
7.0	Flushing/ Backwashing Unit :		
7.1	Type		
7.2	Flushing Valves (if applicable)		
	a) Nos. provided	Nos.	
	b) Type		
	c) Materials		
	• Body		
	• Disc/ Flap		
	• Shaft		
	d) Tag Number		

Name of Bidder/ Vendor

Revision Number	0	1	2	3	4
Signature of Bidder/ Vendor Authorised Representative					



Title
DATA SHEET - B
DEBRIS FILTER
(BACKWASH TYPE)

PECIFICATION NO. PE-TS-999-165-N003

VOLUME III PART A

SHEET 4 OF 9

INSTRUCTION TO BIDDER

- 1 This data sheet shall be read in conjunction with Specification No. PE-TS-999-165-N003 Section - D, Volume - IIB.
- 2 Items which deviate from Specification shall be marked with an asterisk (*)

SL.NO.	ITEM	UNIT	PARTICULARS
7.3	Debris Extractor (if applicable)		
	a) Type		
	b) Materials		
7.4	Debris discharge/ backwash outlet valves		
	a) Type		
	b) Size	mm	
	c) Materials		
	♦ Body		
	♦ Disc/ Trim		
	♦ Shaft		
	d) Tag Number		
7.5	Size of Debris discharge/ backwash outlet valves is greater than pipe line size		YES/NO
7.6	Any water injection is required		YES/ NO
7.7	Whether Pump, valves and piping for water injection is included in the offer.		YES/ NO.
7.8	Debris discharge/ backwash outlet pipe		
	a) Material		
	b) O.D. and thickness	mm	
8.0	Differential Pressure Measuring System:		
8.1	Differential Pressure Switch/ Transmitter		
	a) Type		
	b) Make and Model		
	c) Range		
	d) Accuracy		

Name of Bidder/ Vendor					
Revision Number	0	1	2	3	4
Signature of Bidder/ Vendor Authorised Representative					
Date					



Title
DATA SHEET - B
DEBRIS FILTER
(BACKWASH TYPE)

PECIFICATION NO. PE-TS-999-165-N003

VOLUME III PART A

SHEET 5 OF 9

INSTRUCTION TO BIDDER 1 This data sheet shall be read in conjunction with Specification No. PE-TS-999-165-N003 Section - D, Volume - IIB.
 2 Items which deviate from Specification shall be marked with an asterisk (*)

SL.NO.	ITEM	UNIT	PARTICULARS
	c) Material of sensing element f) No. of contacts g) Contact rating h) Enclosure i) Type of Mounting	Nos.	
8.2	Whether differential Pressure gauge is provided for manual observation.		YES/NO
8.3	Differential Pressure Gauge :		
	a) Type b) Make and Model c) Range d) Accuracy e) Material of sensing element f) No. of contacts g) Dial size h) Enclosure i) Mounting	Nos. mm	
8.4	Whether built in flushing arrangement complete with flushing pump, valves, and associated piping, is provided.		YES/NO
8.5	Whether remote seal type D.P. Transmitter		YES/NO
9.0	Timer for Flushing Operation		
9.1	Timer make		
9.2	Range of duration setting		
10.0	Actuators :		
10.1	Actuators for flushing valves :		

Name of Bidder/ Vendor					
Revision Number	0	1	2	3	4
Signature of Bidder/ Vendor Authorised Representative					

	Title DATA SHEET - B DEBRIS FILTER (BACKWASH TYPE)	PECIFICATION NO. PE-TS-999-165-N003
		VOLUME III PART A
		SHEET 6 OF 9

INSTRUCTION TO BIDDER

1. This data sheet shall be read in conjunction with Specification No. PE-TS-999-165-N003 Section - D, Volume - IIB.

2. Items which deviate from Specification shall be marked with an asterisk (*)

SL.NO.	ITEM	UNIT	PARTICULARS
10.2	a) Type and make b) Nos. provided c) Motor rating Actuators for debris discharge/ backwash outlet valves	KW	
1.03	a) Type and make b) Motor rating Actuator for Debris Extractor	KW	
10.4	Type & make Nos. provided Motor rating Any other		
11.0	Electric Drive Motors		
11.1	Drive motor for water injection pump (if applicable) a) Type and make b) Rating	KW	
11.2	Drive motor for debris extractor a) Type and make b) Rating	KW	
11.3	Drive motor for differential pressure measure, measuring system flushing pump (if applicable). a) Type and make b) Motor rating	KW	

Name of Bidder/ Vendor					
Revision Number	0	1	2	3	4
Signature of Bidder/ Vendor Authorised Representative					
Date					

-48-



Title DATA SHEET - B
DEBRIS FILTER
(BACKWASH TYPE)

PECIFICATION NO. PE-TS-999-165-N003
VOLUME III PART A
SHEET 7 OF 9

INSTRUCTION TO BIDDER 1 This data sheet shall be read in conjunction with Specification No. PE-TS-999-165-N003 Section - D, Volume - IIB.
2 Items which deviate from Specification shall be marked with an asterisk (*)

SL.NO.	ITEM	UNIT	PARTICULARS
11.4	Any other		
12.0	Counter Flanges for inlet & outlet :		
12.1	Nos. provided	Nos.	YES/NO
12.2	Type		
12.3	Size		
12.4	Rating		
12.5	Materials		
	a) Flanges		
	b) Bolts and Nuts		
	c) Gaskets		
12.6.	Code/ Standard		
12.7	Counter flanges for all other terminal points are provided.		YES/NO
13.0	Control Panel		
13.1	Type		
18.2	Model & Manufacturer		
13.3	Operating Voltage/ frequency	V/ Hz	
13.4	Control Voltage/ frequency	V/ Hz	
13.5	Materials of housing and door		
13.6	Protections/ interlocks provided for :		
13.7	Alarms/ Annunciations provided for :		
13.8	Indicators provided for :		

Name of Bidder/ Vendor _____

Revision Number	0	1	2	3	4
Signature of Bidder/ Vendor Authorised Representative					
Date :	- 49 -				

	Title DATA SHEET - B DEBRIS FILTER (BACKWASH TYPE)	PECIFICATION NO. PE-TS-999-165-N003			
		VOLUME III		PART A	
		SHEET 8 OF 9			

INSTRUCTION TO BIDDER

1. This data sheet shall be read in conjunction with Specification No. PE-TS-999-165-N003 Section - D, Volume - IIB.

2. Items which deviate from Specification shall be marked with an asterisk (*)

SL.NO.	ITEM	UNIT	PARTICULARS
13.9	Whether counter to register number of flushing operations, is provided.		YES/ NO
13.10	Whether interconnecting control and power cabling between the control panel and filter is included in the offer.		YES/ NO
14.0	Whether lifting lugs are provided.		YES/ NO.
15.0	Whether supports complete with foundation plates, bolts, nuts, etc. are included in the offer (wherever required).		YES/ NO
16.0	Shop Inspection and Tests		
16.1	Whether all the tests and inspections as detailed in the specification/ quality plan are carried out.		YES/ NO
16.2	Hydorstatic Test :		
	a) Test Pressure	Bar (g)	
	b) Test duration	Minutes	
17.0	Painting :		
17.1	External Surfaces :		
	a) Surface Preparation		
	b) Primer		
	c) Finish		
17.2	Internal Surfaces :		
	a) Surface Preparation		
	b) Primer		
	c) Finish		
18.0	Weights :		

Name of Bidder/ Vendor					
Revision Number	0	1	2	3	4
Signature of Bidder/ Vendor Authorised Representative					

-50-

	Title DATA SHEET - B DEBRIS FILTER (BACKWASH TYPE)	PECIFICATION NO. PE-TS-999-165-N003	
		VOLUME III	PART A
		SHEET 9 OF 9	

INSTRUCTION TO BIDDER

- This data sheet shall be read in conjunction with Specification No. PE-TS-999-165-N003 Section - D, Volume - IIB.
- Items which deviate from Specification shall be marked with an asterisk (*)

SL.NO.	ITEM	UNIT	PARTICULARS
18.1	Empty Weight	Kg.	
18.2	Operating	kg	
19.0	Overall Dimensions		
	a) Debris Filter		
	b) Flushing skid		
	c) D.P. measuring system skid		
20.0	Weight of heaviest unit/ component to be handled.		
21.0	Space required for removal.		
22.0	Headroom required during installation at site.		
23.0	Other information (if any)		
	G:\MSEVASHDS-DF.RTF		

Name of Bidder/ Vendor					
Revision Number	0	1	2	3	4
Signature of Bidder/ Vendor Authorised Representative					
Date					

-51-

	TITLE	SPECIFICATION NO.
	MOTOR DATA SHEET - C	VOLUME II B
		SECTION D
		REV NO. 00 DATE 29/08/2005
		SHEET 1 OF 2

S. No.	Description	Data to be filled by successful bidder
A.	General	
1	Manufacturer & country of origin	
2	Motor type	
3	Type of starting	
4	Name of the equipment driven by motor & Quantity	
5	Maximum Power requirement of driven equipment	
6	Rated speed of Driven Equipment	
7	Design ambient temperature	
B.	Design and Performance Data	
1	Frame size & type designation	
2	Type of duty	
3	Rated Voltage	
4	Permissible variation for	
5	a) Voltage	
6	b) Frequency	
7	c) Combined voltage & frequency	
8	Rated output at design ambient temp (by resistance method)	
9	Synchronous speed & Rated slip	
10	Minimum permissible starting voltage	
11	Starting time in sec with mechanism coupled	
12	a) At rated voltage	
13	b) At min starting voltage	
14	Locked rotor current as percentage of FLC (including IS tolerance)	
15	Torque	
	a) Starting	
	b) Maximum	
16	Permissible temp rise at rated output over ambient temp & method	
17	Noise level at 1.0 m (dB)	
18	Amplitude of vibration	
19	Efficiency & P.F. at rated voltage & frequency	
	a) At 100% load	
	c) At 75% load	

NAME OF VENDOR			SEAL	REV.	
NAME	SIGNATURE	DATE			

	TITLE	SPECIFICATION NO.
	MOTOR DATA SHEET - C	VOLUME II B
		SECTION D
		REV NO. 00 DATE 29/08/2005
		SHEET 2 OF 2

S. No.	Description	Data to be filled by successful bidder
	c) At starting	
C.	Constructional Features	
1	Method of connection of motor driven equipment	
2	Applicable Standard	
3	DOP of Enclosure	
4	Method of cooling	
5	Class of insulation	
6	Main terminal box	
	a) Type	
	b) Power Cable details (Conductor, size, armour/unarmour)	
	c) Cable Gland & lugs details (Size, type & material)	
	d) Permissible Fault level (kArms & duration in sec)	
7	Space heater details (Voltage & watts)	
8	Flame proof motor details (if applicable)	
	a) Enclosure	
	b) suitability for hazardous area	
	i Zone	O / I / II
	ii Group	IIA / IIB / IIC
9	No. of Stator winding	
10	Winding connection	
11	Kind of rotor winding	
12	Kind of bearings	
13	Direction of rotation when viewed from NDE	
14	Paint Shade & type	
15	Net weight of motor	
16	Outline mounting drawing No (To be enclosed as annexure)	
D.	Characteristic curves/ drawings (To be enclosed for motors of rating $\geq 55KW$)	
	a) Torque speed characteristic	
	b) Thermal withstand characteristic	
	c) Current vs time	
	d) Speed vs time	

NAME OF VENDOR			SEAL	REV.	
NAME	SIGNATURE	DATE			



TITLE :
TECHNICAL SPECIFICATION FOR
DF

SPEC. NO. PE-TS- 410-165-N001

VOLUME III

SECTION

REV. NO. 0

DATE 18.06.2015

SHEET 1 OF 1

SECTION B2
LIST OF SCHEDULES

CHECKLIST — LIST OF SCHEDULES

Sl. No.	Form No.	Description	Tick Applicable Forms
1	PEM-6024	Schedule of Drawings / Catalogues submitted with Bid	✓
2	PEM-6025 @	Schedule of Occurance of Key Events of Delivery, Erection & Commissioning	
3	PEM-6026	Schedule of Equipment Manufacture, Despatch and Shipment to Site.	✓
4	PEM-6027	Schedule of Weights & Dimensions	✓
5	PEM-6028 @	Schedule of Performance Guarantee	
6	PEM-6030	Inspection Schedule	✓
7	PEM-6031	Schedule of Cement and Steel and Quarterly Cement Requirement	
8	PEM-6032	Schedule of Quarterly Requirement of Reinforcing Bars and Structural Steel	
9	PEM-6033 @	Bill of Quantities (Civil Works)	
10	PEM-6035	Schedule of Bidder's Proposed Construction / Site Fabrication Facilities.	
11	PEM-6036	Schedule of Deviations	✓
12	PEM-6040	Schedule of Declaration	✓
13	PEM-6041	Quality Plan	✓
14	PEM-6042	Vendor's Drawings / Documents Schedule	✓
15	PEM-6043 @	Schedule of Occurance of Key Events for Civil / Structural Works	
16	PEM-6046	Inspection Request	✓
17	PEM-6051	Schedule of Prices	✓
18	PEM-6052 @	Schedule of Unit Prices	✓
19	PEM-6053	Schedule of Prices for Commissioning & Mandatory Spares	✓
20	PEM-6054	Schedule of Prices for Recommended Spares	✓
21	PEM-6055	Schedule Prices for Erection and Maintenance Tools & Tackles	✓
22	PEM-6056	Schedule of Bidder's Man-power for Supervision of E & C and their Charges.	✓
23	PEM-6057	Schedule of Daily & Overtime Rates	
24	PEM-6058	Schedule of Hire-charges for Construction / Site Fabrication Facilities	
For Forms marked with @ certain information to be filled by DEs - before issuing to bidder.			



**SCHEDULE OF DRAWINGS /
CATALOGUES SUBMITTED WITH BID**

PE-70-214 230 232 233 234-

165-N001

PART - A

SHEET

Section C/D enclosed with the specification indicate the drawings / catalogues to be furnished with the bid. The bidder in addition to furnishing the same, can also include any other drawings / catalogues which he may desire to submit with the bid. This schedule duly lists out such drawings as enclosed by the bidder with the bid.

DRAWING CATALOGUE NUMBER	DESCRIPTION	NUMBER OF SHEETS

PARTICULARS OF BIDDER AUTHORIZED REPRESENTATIVE



SCHEDULE OF
WEIGHTS & DIMENSIONS

PE-TS-214/230 232 233/234-
165-N001

VOLUME III PART - A

SHEET OF

The bidder shall state below the weights and dimensions of various packages for shipment covering the complete scope

Description of Package(s)	Dimensions (in meters)	Weight (in tonnes)

PARTICULARS OF BIDDER AUTHORIZED REPRESENTATIVE

-55-



SCHEDULE OF EQUIPMENT, MANUFACTURE, DESPATCH AND SHIPMENT TO SITE

PROJECT NO. PE-TC-014/030 030/033 034-
165-N001

VOLUME NO. PART - A

SHEET OF

Equipment Major Bought-out Items	Time for Manufacture Procurement from Date of Issue of Letter of Intent (Weeks)	Time for Test, Dismantling Packing & Ready for Despatch (Weeks)	Time required for Shipment to Site (Weeks)	Total Time from Date of Issue of Letter of Intent to Shipment to Site (Weeks)

We the undersigned hereby undertake to meet the above time schedule in weeks for manufacture, despatch and shipment of each equipment and procurement of major boughtout items as listed above

PARTICULARS OF BIDDER AUTHORIZED REPRESENTATIVE



INSPECTION SCHEDULE

SECTION PE-TS-214/230/232/233/234 165-N00

P.O.
NUMBER

VOLUME - PART-A

SHEET OF

S. No.	ITEM/COMPONENT	PLACE & ADDRESS OF TEST / INSPECTION	Scheduled Date of Inspection	Duration of Test / Inspection (in days)

This schedule shall be in line with specification and quality plan requirements. The information in this form shall be furnished after receipt of LOI / PO

PARTICULARS OF VENDOR'S AUTHORIZED REPRESENTATIVE

48

SPEC NO PE-13-214-2-5
233/234-165-1061

SPECIFICATION FOR
COLLECTOR'S DE

SECTION VOLUME III

PROJECT TITLE

QUALITY PLAN NUMBER

ITEM

CUSTOMER

BIDDER / VENDOR

SYSTEM

QUALITY PLAN

SHEET OF

COMPONENT / OPERATION	CHARACTERISTIC CHECK	CAT.	TYPE / METHOD OF CHECK	EXTENT OF CHECK	REFERENCE DOCUMENT	ACCEPTANCE CRITERIA	FORMAT OF RECORD	AGENCY			REMARKS
								P	W	V	
2	3	4	5	6	7	8	9	10			

BIDDER / VENDOR

PARTICULARS

NAME

SIGNATURE

DATE

BIDDER'S / VENDOR'S COMPANY SEAL

58

INSTRUCTIONS FOR FILLING QUALITY PLAN
(Form No. PEM-6042-0)

The Quality Plan shall include all the Quality Control Measures and Checks adopted by the Vendor to ensure that the material component/assembly services supplied by him meet/will meet the requirements as per specifications and good practices. They shall include all stages of operation such as materials, processes, manufacture, assembly, packing and despatch. The following guide lines may be noted

- Column 1- Serial Number
- Column 2- Component/Operation- The component and/or operation being checked shall be given here.
- Column 3- Characteristics check- The characteristics being checked shall be given here, e.g., chemical composition, mechanical properties, leak tightness, surface defects etc.
- Column 4- Category - 'CR' stands for critical characteristic - affecting safety of equipment and personnel
'MA' stands for major Characteristic - affecting safety of equipment and personnel
'MI' stands for minor characteristic - affecting appearance etc
- Column 5- Type/Method of check e.g chemical analysis tensile testing, hydraulic test, visual examination radiography etc
- Column 6- Extent of check, such as, 100, 10, 1 per heat etc.
- Column 7- Reference Documents - Documents, such as technical specification, drawings, standard specifications (IS, BS ETC.) procedure, etc. according to which check is done.
- Column 8- Acceptance Norms - Standards etc. according to which acceptability or otherwise of the characteristics being checked is decided.
- Column 9- Format of Record - Formats, log sheets, reports, etc. in which the observations are recorded. Standard log sheets, reports, formats etc. of the Vendors shall be numbered and such reference numbers shall be included here.
- Column 10- Agency - The agency which performs the test/instruction shall be written in sub-column 'W'
The agency which verifies test certificates/inspection records and carries out audit check of the components/operation shall be written in sub-column 'V'
The agencies are codified '1' stands for (BHEL)
as 1,2 & 3 '1*' means the operation shall be cleared by BHEL before the start of the next operation.
'2' Stands for Vendor
'3' stands for sub-Vendor of the Vendor and so on.

Example :

- Entry '3' in column 'P' means test/inspection to be performed by sub-Vendor's QC
- Entry '2' in column 'W' means test/inspection to be witnessed by Vendor's QC
- Entry '1' in column 'V' means verification shall be done by BHEL and next stage to be started only after the hold point is cleared by BHEL
- Column 11- Remarks - Any special remarks shall be given here

NOTES

- 1 In absence of correlation with the test certificate(s) (e.g. material identification) samples shall be drawn by BHEL and all tests as per relevant specifications shall be carried out in their presence or in recognized Government Laboratory.
- 2 When materials and components are initially identified and stamped by BHEL QS engineer, the identification marks shall be preserved till despatch. Wherever this is not possible, the identification mark shall be transferred to the components in the presence of BHEL QS Engineer unless other wise agreed
- 3 For castings and forgings integral test specimens shall be provided. When this is not possible for casting, they shall be poured in the presence of BHEL QS Engineer unless otherwise, if witnessing of test by BHEL, is called for
- 4 When welders qualified by reputed inspection agencies or statutory bodies are not available, qualification tests shall be conducted in the presence of BHEL QS Engineer
- 5 This Quality Plan is liable to be modified as per the requirements of approved drawings and changes in technical specifications drawings. If there are contradictions in respect of column 7 & 8 between this Quality Plan and the approved drawings specifications the latter shall prevail
- 6 Wherever inspection by BHEL's Purchaser Third Party Statutory authorities are mandatory this shall be complied with
- 7 Inspection reports log sheets test reports certificate etc shall be furnished to BHEL of the appropriate stage or at the time of final inspection as required
- 8 The Quality Plan is also applicable to spares of the under scope of supply of Vendor



INSPECTION SCHEDULE

PE-TS-214-230-232-233-234-165-NCC

P.O.
NUMBER

VOLUME (PART) A

SHEET OF

S. No.	ITEM/COMPONENT	PLACE & ADDRESS OF TEST / INSPECTION	Scheduled Date of Inspection	Duration of Test / Inspection (in days)

This schedule shall be in line with specification and quality plan requirements. The information in this form shall be furnished after receipt of LOI - PO

INSPECTORS OF VENDOR AUTHORIZED REPRESENTATIVE

COMPANY SEAL

51



*** SCHEDULE OF DECLARATION**

PE-TS-214/230 232 233/234-
165-N001

TITLE SHEET PART - A

SHEET OF

DECLARATION

I.....certify that all the technical data and information pertaining to this specification are correct and are true representation of the equipment/system covered by our formal proposal number Dated..... and there is no deviation to the specification.

I hereby certify that I am duly authorised representative of the Bidder's company whose name appears above my signature.

Bidders Company Name

Authorised representative's Signature

Name

Bidder's Intent The bidder hereby agrees to fully comply with the requirements and intent of this specifications for the price indicated.

PERCEI APS OF BIDDER AUTHORIZED REPRESENTATIVE



*** SCHEDULE OF PRICES FOR
COMMISSIONING AND MANDATORY
SPARES**

REVISIONS TO BE INDICATED BY THE BIDDER

VOLUME III

SHEET OF

The bidder shall indicate here the quantity required for erection, commissioning and mandatory spares for equipment as listed in Section-C / Section - D. If the listed spares are not adequate, then the bidder shall indicate those and additional spares considered necessary by him.

Type	Manufacturer's Drawing No. / Part of spare	Description	Material	Quantity per Unit of Equipment	Quantity Required	If set. Nos. Per set	Delivery period (Weeks)	Unit Price (Rs)	Total Price (Rs)
Erection and Commissioning									
Mandatory Spares									
Mandatory Erection / Commissioning									

PARTICULARS OF BIDDER AUTHORIZED REPRESENTATIVE -

FORM No. P/EM-0450-0



**SCHEDULE OF BIDDER'S MAN POWER
FOR SUPERVISION OF E & C
AND THEIR CHARGES**

PROJECT NO. _____
 VOLUME _____
 SHEET _____ OF _____

The bidder shall indicate below, designation-wise, the personnel required for supervision of erection and commissioning and their charges.

SUPERVISION OF ERECTION

Sl. No.	Designation	Normal rate per day of 8 hours	Overtime rate per hour

SUPERVISION OF COMMISSIONING

Sl. No.	Designation	Normal rate per day of 8 hours	Overtime rate per hour

DETAILS OF BIDDER AUTHORIZED REPRESENTATIVE

65

68