

प्रलेख संख्या DOC. No	TB-383-563-033	Rev. No.	00	बनाया/ Prepared	जांचा/ Checked	स्वीकृती/ Approved	
TYPE/ प्रकार OF DOC.	TECHNICAL SPECIFICATION			हस्ता. / SIGN	[Handwritten Signatures]		
TITLE/ शीर्षक	EOT CRANE (GAS INSULATED SUBSTATION BUILDING)			नाम / NAME	TDT	SKS	NSR
				दिनांक/ DATE	11.07.16	11.07.16	11.07.16
				समूह/GROUP	TBEM	W.O. No	85001
ग्राहक/ CUSTOMER	OIL AND NATURAL GAS CORPORATION LIMITED (ONGC LTD.)						
परामर्शदाता/ CONSULTAN	FICHTNER CONSULTING ENGINEERS (INDIA) PVT. LTD.						
परियोजना/ PROJECT	51 MW COMBINED CYCLE CAPTIVE POWER PLANT – 66 KV GIS AT HAZIRA						

विषय-सूचि/ CONTENTS

अनुभाग / Section	विवरण / Description	पृष्ठसंख्या/ No of Pages
1	Intent, System and scope a. <u>ANNEXURES TO SECTION - 1</u> Annexure-A – List of cables procured by BHEL (1 Page) Annexure - I – TS for VVVF Drives (5 Pages) Annexure-II – Make of Sub Vendor Items (2 Pages) Annexure-III – Procedure for Overload testing (1 Page)	15
2	Equipment Specification	11
3	Project details and general specifications	12
4	List of Documents	07
5	Schedule to be filled by Bidder b. <u>ENCLOSURES TO SECTION - 5</u> Layout plan for 66kV GIS, Conceptual plan for GIS building MQP – EOT Crane.	08

Rev No.	Date	Altered	Checked	Approved	REVISION DETAILS				
Distribution					To	TBEM	TBMM	TBQM	Vendor

COPYRIGHT AND CONFIDENTIALITY

The information on this document is the property of BHARAT HEAVY ELECTRICALS LTD.
It must not be used directly or indirectly in anyway detrimental to the interest of the company



SECTION 1

INTENT, SYSTEM REQUIREMENT, DESIGN CRITERIA AND SCOPE

1.0 INTENT OF SPECIFICATION

- 1.0.0 This specification is intended to cover following activities and services in respect of all the equipment of the **Single Girder EOT Crane of 3.5 tonnes capacity to be provided for 66 kV Gas Insulated Substation Building at 1 x 51 MW Combined cycle captive power plant (CCPP), Hazira, Gujarat.**
- Detailed design of all the equipment and equipment system(s).
 - Complete manufacturing including shop testing.
 - Providing engineering data, drawings, and O & M manuals as per specified format etc. for owners/purchaser's review, approval and records.
 - Packing and transportation from the manufacturer's works to the site including customs clearance/port clearance, if required.
 - Receipt, storage, preservation and conservation of equipment at site.
 - Fabrication, pre-assembly, if any, erection testing and putting into satisfactory operation all the equipment including successful completion of trial operation.
 - Performance and Guarantee tests after successful completion of trial operation.
- 1.0.1 The requirements specified under SECTION 2, SECTION 3, SECTION 4 & SECTION 5 of the specification shall be considered as part of this section. In the event of any conflict between the various sections/sub-sections of this specification, SECTION 1 shall prevail.
- 1.0.2 It is not the intent to specify herein all the details of design and manufacture. However, the equipment and the system shall conform in all respects to high standards of design, engineering and workmanship and shall be capable of performing the required duties in a manner acceptable to Purchaser/ Owner, who will interpret the meaning of drawings and specifications and shall be entitled to reject any work or material, which in his judgment is not in full accordance herewith.
- 1.0.3 **Contract shall be on lumpsum basis for the scope defined in the specification. Variations in quantities during contract stage without any change in input from BHEL side shall not have any commercial implications. The Bidder shall be responsible for providing all material, equipment and services, specified or otherwise which are required to fulfill the intent of ensuring operability, maintainability and the reliability of the complete work covered under this specification.**
- 1.0.4 The Bidder shall deem to have understood completely all the tender drawings and documents and quoted accordingly.
- 1.0.5 **Deviation:** There shall preferably be no deviation on technical specification. The bidder shall sign and stamp the "Certificate for No Deviation" enclosed in Schedule-2, Section-5 towards confirmation. Except for these deviations/variations covered under Deviation Schedules which are accepted by the Purchaser before the award of the Contract, it will be the responsibility of the Bidder to fully meet the intent and the requirements of the

	CLIENT – OIL & NATURAL GAS CORPORATION (ONGC) PROJECT: 1 X 51 MW CCCPP, HAZIRA, GUJARAT - 66 KV GIS CONSULTANT- FICHTNER CONSULTING ENGINEERS (INDIA) PVT. LTD. TECHNICAL SPECIFICATION FOR EOT CRANE	TB-383-563-033
		Rev. 0
		Page 2

specification within the quoted price. *Deviations in any other form including clarifications / assumptions / etc will not be considered and it will be construed that the bid conforms strictly to the specification.*

- 1.0.6 The Bidder to note carefully that the parameters, estimated capacities of equipment indicated and the tender drawings in the specification are only for the guidance of the Bidder. The system shall be designed as per relevant standards/ codes and exact capacities and quantities are to be estimated by the Bidder. All such estimations and design calculations shall be submitted for Purchaser's approval.
- 1.0.7 It is the responsibility of the successful Bidder to obtain necessary approval/ clearance from statutory organizations wherever applicable for the equipment/ systems under the scope specified.
- 1.0.8 The term '**Owner**' appearing in this specification shall refer to **Oil & Natural Gas Corporation (ONGC)**, the term '**Consultant**' shall refer to **Fichtner**, the term '**Purchaser**' shall refer to **BHEL** and the term '**Contractor**' shall refer to the **successful Bidder**.

2.0 SCOPE

One no. (1) Single girder Electrically Operated Travelling Crane or SG EOT Cranes having 3.5 tones capacity with Variable Voltage Variable Frequency i.e. VVVF Drive suitable for erection of various equipment at 66 kV GIS Building at Hazira GIS Substation shall be supplied by the contractor.

EOT crane shall have Variable Voltage Variable Frequency drive details of which are given in Annexure I to Sec-1.

Bidder's responsibility include design, engineering ,manufacture, assembly/pre-assembly, tests at manufacturer's works, shop painting & packing and transportation to site of the equipment complete with all the auxiliaries as specified hereunder for trouble free and satisfactory operation to the Purchaser.

3.0 SCOPE OF SUPPLY AND SERVICES

The requirements mentioned in this clause are indicative only and the exact requirements shall be worked out during detailed engineering after award of contract. The scope of the work under the contract shall be deemed to include all such items, which although not specifically mentioned in the bid documents and/or in the bidder's proposal, but are required to make the equipment/system complete for its safe, efficient, reliable and trouble free operation, unless the same is specifically excluded from the bidder's scope of work under clause 5.1 of this section.

3.1 SUPPLIES

Equipment and services to be furnished by the bidder for the Single Girder EOT Crane with accessories as per the details given in data sheet A. Any equipment / accessories not specified in the specification but required to make the crane units complete and efficient shall also be under the bidder's scope of work.

Each EOT crane shall include all necessary items but shall not be limited to the following:

- i. Bridge girder.
- ii. End carriages complete with wheels
- iii. Electric Hoist (For EOT Crane)
- iv. CT / L T drive arrangement
- v. Electrical equipment

	CLIENT – OIL & NATURAL GAS CORPORATION (ONGC) PROJECT: 1 X 51 MW CCCPP, HAZIRA, GUJARAT - 66 KV GIS CONSULTANT- FICHTNER CONSULTING ENGINEERS (INDIA) PVT. LTD. TECHNICAL SPECIFICATION FOR EOT CRANE	TB-383-563-033
		Rev. 0
		Page 3

- vi. PVC Shrouded Conductor Bus Bar Type DSL with accessories for entire bay length.
- vii. Earthing arrangement.
- viii. Mandatory spares **(Refer Annexure IV)**
- ix. First fill of lubricant.
- x. Main isolating switch and power cable from 1.5 m above ground / operating floor to down shop lead.

3.2 Services to be provided by the bidder

1. Packing, loading, transportation to site, unloading & storage at site
2. Erection, testing and commissioning at site.

3.3 Inspection and Testing

Inspection and testing at Manufacturer's works

A. Shop inspection and tests will include but not limited to the following -

- i. Identification, co-relation and verification of material test certificates for the important components like girders, major load carrying components, hooks, gears, shafts, wheels, wire, rope drum, wire rope etc. For other components supporting test certificates or random check tests shall be conducted.
- ii. Qualification of welder and welding procedure as per ASME section 1X of ASTM -7.1.
- iii. 100% radiography of tension zone & 25% radiography of compression butt welds of load bearing members shall be carried over and all butt welds as per ASME- 165/ASTME 109 and acceptance norm as per ASME Section viii Div.1.
- iv. For fillet welds visual inspection on all welds. Die penetration test (DPT) for fillet welds in the load bearing members as per ASME-165/ASTME 109 and acceptance norm as per ASME section VIII Div. 1.
- v. Ultrasonic test on forgings and casting of critical components like hook, shafts, axles, gears, wheels, pulleys, etc. Ultrasonic test for casting as per ASME Section III NB 2572 & for forging as per ASTM A388.
- vi. Unacceptable defects in forgings are as given below: -
 - a. Cracks, flaws, seams and laps.
 - b. Defects giving indication larger than 4mm diameter equivalent flaw.
 - c. Groups of defects with maximum indication less than that from a 4mm dia, equivalent flaw, which cannot be separated at testing sensitivity if the back echo is reduced by 50%.
 - d. Defects giving indication of 2 to 4 mm diameter equivalent flaw separated by a distance less than 4 the size of the larger of the adjacent flaws.
- vii. PT/ MT on component with surface hardening as per ASTM -165 and ASTM 138 respectively with no surface defects.
- viii. Gearbox trial run test as per AGMA standards.
- ix. Verification of type test certificates and enclosure for electrical and electro mechanical items. If type test certificates of the similar items are not available, arrangement shall be made to conduct the same in the presence of BHEL/ Customers representative.
- x. Acceptance and routine tests (HV and insulation) for all electrical and electromechanical components and system

	CLIENT – OIL & NATURAL GAS CORPORATION (ONGC) PROJECT: 1 X 51 MW CCCPP, HAZIRA, GUJARAT - 66 KV GIS CONSULTANT- FICHTNER CONSULTING ENGINEERS (INDIA) PVT. LTD. TECHNICAL SPECIFICATION FOR EOT CRANE	TB-383-563-033
		Rev. 0
		Page 4

as per governing specification

- xi. Functional and simulated operation test, sequencing, interlocks, safety, protection and alarm system. Test on CRANE/ CRAB motors and other mechanical, electrical, electro-mechanical as per BHEL technical specification and or as per applicable code
- xii. Cranes shall be completely assembled at manufacturer's works to check the misalignment of gears, shafts and other items. Gears shall have the idle run for minimum two (2) hours.

B. Testing At Works

- i. Deflection test of bridge girder at rated load
- ii. No load / load (EWL) / Over load test (running of CT & Hoisting mechanism at 125% of rated load.)
- iii. Electrical tests for brakes, panel, electrical equipment etc. as per IS - 3177
- iv. No load run test of LT mechanism
- v. Measurement of speed of CT & Hoisting (lowering & raising) at rated load
- vi. All Other tests as per IS - 3177.

3.4 Testing at site

Following tests shall be carried out at site as a part of ETC scope:

- a) All the tests as mentioned above, with actual hook and wire rope
- b) Speed test at rated load for hoisting / CT and LT mechanism
- c) Brake test and working of both electric hoist
- d) Any other test as per IS-3177-1999.

The successful bidder shall furnish their recommended procedure for carrying out the Erection and Commissioning, to be done by the customer.

4.1. Drawing / design document for submission.

A. For Approval

- a) G.A. drawing showing clearances, assembly, cross section details, materials of construction, lifts and hook approach.
- b) Hoist assembly.
- c) DSL fixing arrangement and supports
- d) Motors HP/KW calculations, brake selection calculation, cable sizing calculations, voltages drop calculation etc.
- e) Gantry Rail fixing Arrangement with accessories. (If applicable)
- f) Write up on the crane control.
- g) Wire rope selection, gearbox selection, rope drum selection and wheel size selection calculation
- h) Electrical wiring diagram and control scheme
- i) Quality Plan.
- j) Test certificates and reports on various shop tests.
- k) Field quality plans.
- l) O.M. Manuals
- m) Technical data sheet of all equipment / components

B. For Reference



- a) Hook block assy. And gear box drawings.
- b) Rope drum assy. drug.
- c) Cross conductor on bridge.
- d) Crane lubrication arrangement
- e) LT & CT wheel Assembly drawing
- f) Manufacturers catalog
- g) Motor characteristics curves.
- h) Structural Calculation
- i) Detailed erection drawing (as erection shall be carried by customer himself complete erection procedure, literature and necessary erection drawing shall be provided).

5.1. Works Excluded

5.1.1. Supply of steel gantry girders & rails.

5.1.2. For EOT crane, the purchaser shall provide single point 415V, 3 phase, and 50Hz power feeder at any point of the bay or in the middle of the bay as specified in the Data sheet-A. Vendor shall provide main isolating switch at 1.5 M above the ground / operating floor level and cable required from isolating switch to DSL.

Any other supply required by the bidder shall be arranged by the bidder himself by using suitable transformer as per the specification.

5.1.3. Supply of Power and control cable (Except for the cables being provided as a standard part of crane).

5.1.4. Supply of cable tray/ racks.

5.1.5. Supply of Earthing flats.

6.0. Performance Guarantee

EOT crane along with its drives, controls and other accessories shall be guaranteed for the rated capacity against the rated speed of motions and for the service conditions specified

The bidder shall have the full responsibility for the safe and efficient operation of the crane with associated accessories as a single unit.

Failure of any of the components to achieve the guaranteed performance, the deficiency shall be made good at bidder's cost.

Performance tests shall be carried out each time after the rectification /modification is carried out.

7.0 Make of Sub - Vendor items

The makes of bought out items will be as per Annexure-II, of the specification. No other make will be acceptable, until and unless specifically got it approved by the purchaser.

8.0 Various Heads to be quoted

Sl. No.	Item Description	Unit	Quantity	Total Exworks	Total ETC
1	3.5 Ton EOT Crane as per specification	Lot	1		
2	Mandatory Spares as per annexure-IV	Lot	1		NA



ANNEXURE-'A'

Cable Sizes being procured by BHEL for Sub-Station

Sl. No	Item Desc.
1	2C x 2.5 sq. mm PVC/Copper, Armoured Control cable
2	5C x 2.5 sq. mm PVC/Copper, Armoured Control cable
3	10C x 2.5 sq. mm PVC/Copper, Armoured Control cable
4	14C x 2.5 sq. mm PVC/Copper, Armoured Control cable
5	19C x 2.5 sq. mm PVC/Copper, Armoured Control cable
6	4C x 10 sq. mm PVC/Copper, Armoured Control cable
7	2C x 6 sq. mm PVC/Aluminium, Armoured Aux. Power cable
8	4C x 16 sq. mm PVC/Aluminium, Armoured Aux. Power cable
9	3.5C x 70 sq. mm PVC/Aluminium, Armoured Aux. Power cable
10	3.5C x 150 sq. mm XLPE/Aluminium, Armoured Aux. Power cable
11	3.5C x 300 sq. mm XLPE/Aluminium, Armoured Aux. Power cable
12	2C x 150 sq. mm XLPE/Aluminium, Armoured Aux. Power cable



ANNEXURE I

TECHNICAL SPECIFICATION FOR VVVF DRIVES

1.0 General

a) This part of the specification describes the general requirements for the Variable Voltage Variable frequency Drives, herein referred to as AC Drives, for use with standard IEC design AC squirrel cage induction motors. The nominal values, the standard documents and the drive's minimum performance is defined in this part. To avoid any mismatch between the motor and its control equipment, the AC Drive shall be capable of auto adjustment by automatic measurement of the motor parameters with/without motor rotation.

b) Inverter construction and related devices:

Construction shall be divided in 3 broad sections. Section one converts AC Supply into DC supply. Section 2 Converts and controls DC supply into AC Supply with regulation. Section 3 shall be used for braking action of the motor and Dynamic Braking Unit (DBU) can be inbuilt or external depending upon the drive capacity. VVVF can be used in open loop (without external speed feedback) like in Travel motions or close loop (With external speed feedback) like in Hoist motions. Chokes on input supply side are generally used in crane application for power regulation. Like all other electronic / electric devices VVVF drives are also protected by MCB / MCCB / Fuses. VVVF drives are sensitive to temperature and hence drive internal as well as external cooling fans are provided.

c) Programming of VVVF Drives.

VVVF drives shall be programmable and for that purpose detachable digital Operator display unit shall be supplied along with the VVVF having required buttons for setting the user constant, functions etc. The VVVF drive is to be fine-tuned by matching the motor parameters and setting the parameters on full load.

d) VVVF drives shall be connected with power supply and these drives generate their own low voltage control supply. Potential free contacts shall be connected to this control supply and few programmable control terminals. Starting / stopping / set speeds operations of VVVF drive shall be achieved by above control connection.

e) VVVF shall give smooth control over acceleration and deceleration making the motion jerk free and using Variable voltage variable frequency limits the inrush current to the squirrel cage motors. VVVF provides controlled torque to the motor due to which crane operations are jerk free.

1.1 Experience

The Frequency Converter Manufacturer shall have adequate experience in frequency converter manufacturing and have adequate business volume in order to provide credibility in his commitments and a capability of long term support.

1.2 Local support

The Supplier shall have a permanent representative office with a trained and skilled support staff, in the country where the goods are delivered, in order to prove his commitment for local support and to provide a channel for communication.

The engineers employed by the Supplier's regional office shall be certified by the Manufacturer and provide start-up service including physical inspection of the drive, connected wiring and final adjustments, to ensure that the AC Drive meets the required performance.



The Supplier shall be able to give basic drives training to the Customer's engineers, preferably on the site. The training shall, as a minimum, include system concepts and basic troubleshooting.

2.0 Basic requirements for the AC Drives

2.1 General requirements

The AC Drive shall comply with National (country of origin) and International standards and the recommendations for electrical industrial control devices (IEC, EN, UL, NFC, and VDE).

The AC Drive shall be of the most modern design, yet user friendly and be simple to install, commission and maintain. The AC Drive shall be able to start and control the speed of a standard squirrel cage induction AC motor. The AC Drives shall be: CE marked, conforming to European Low Voltage (73/23/CEE and 93/68/CEE) and EMC (89/336/CEE) Directives, UL/CSA marked according to UL 508C.

The AC Drives have to be built to comply with the IEC standards.

The AC Drive shall be a digitally controlled drive, using, at least, the Pulse Width Modulation (PWM) with flux vector control open loop (for travel) and closed loop (for hoist). It shall have diodes / thyristors in rectifier and IGBT's in the inverter section in their entire power range, and it shall have the following minimum specifications.

Rated Input Voltages	380V -15% 480V +10%, three-phase
Rated Input Frequency	50Hz +/- 5%
Output Voltage	0 – Input voltage, three-phase
Output Frequency Range	0 to 400 Hz
Acceleration / Deceleration Time	0.01 – 999s, adjustable, linear, with S, with U or customised shapes
Overload capability (Constant Torque)	150% of nominal current for 1min.
Operating ambient Temperature	-10°C up to 50°C (shall be derated suitably if not rated at 50°C)
Storage ambient Temperature	-25°C up to 70 °C
Maximum operating altitude	1000 m without de-rating, 1000...3000 (shall be de-rated suitably)
Max. Relative Humidity	95 %, without condensation and dripping water.
Main Protections	Over current, short circuit between phase, short circuit between phase and ground, input phase loss, output phase loss, motor overload, over speed, over voltage, under voltage, drive over temperature

The AC Drive shall be able to give a 100% output current continuously in the above specified conditions. In order to ensure that the drive can provide the required output current in the specified ambient conditions, the Manufacturer shall inform the required derating, if the ambient temperature given in the project-specific specification is higher than rated ambient of the drive or if the installation altitude is more than 1000 m above



the sea level. The de-rating factor shall be specified so that neither the lifetime of the AC Drive nor the unit's performance, overload capability included, nor the reliability of the AC Drive shall suffer.
 Suitable encoder shall be provided for main hoist motion.

3.0 User interface

3.1 General

The user interface shall be identical throughout the power range and type to avoid confusion amongst the users and need for training in several different units.

3.2 Inputs and outputs

- A. At least, the following standard Inputs and Outputs shall be provided, to be used in interface with the control system:

- Analogue Inputs : 1 x Programmable differential voltage input $\pm 10V$,
 1 x Programmable current input 0(4) - 20mA
 1 x Programmable voltage input 0 – 10V
- Analogue Output : 1 x Programmable analogue outputs 0(4) - 20mA or 0 – 10V
- Logic inputs : 6 x Programmable logic Inputs isolated from the mains
- Relay Outputs : 2 x Programmable Digital outputs with a changeover dry contact
- All the control terminals shall be clearly marked.

At least, it shall be possible to assigned the following functions to the I/Os:

Analogue input	Analogue outputs
Speed reference Summing reference	Motor current Motor frequency Motor torque Motor power
Logic input	Relay or logic outputs (open collector)
Forward Reverse Jog Preset speeds Reference switching Ramp switching Parameter sets selection Fast stop Freewheel stop + Speed - Speed External fault	Ready Drive running High speed attained Drive fault Frequency threshold attained Motor thermal state attained Torque or current limitation attained Brake control

3.4 Programming terminal

- A. The AC drive shall have a keypad /display for programming and controlling purposes. An IP54 or IP65

	CLIENT – OIL & NATURAL GAS CORPORATION (ONGC) PROJECT: 1 X 51 MW CCCPP, HAZIRA, GUJARAT - 66 KV GIS CONSULTANT- FICHTNER CONSULTING ENGINEERS (INDIA) PVT. LTD. TECHNICAL SPECIFICATION FOR EOT CRANE	TB-383-563-033
		Rev. 0
		Page 10

remote mounting shall be possible at a distance of 10m.

- B. Password protection shall be provided to avoid unauthorized tampering with the set parameters.
- C. The programming terminal shall be able to display the commercial reference of the AC drive and of the options, the software version, the serial number
- D. Direct keypad entry shall be provided to observe the following actual parameters. Any one of the following parameters or actual values shall be selected to be always displayed:-
 - i) Input Voltage
 - ii) Input Frequency
 - iii) Output Frequency
 - iv) Output Power
 - v) Output Current
 - vi) Motor Speed

The following parameters shall always be displayed during normal operation: -

- i) Drive Status
 - The following drive control functions at least shall be available from the keypad:-
 - i) Run
 - ii) Stop
 - iii) Local / Remote selection.
 - iv) Forward/Reverse (if function enabled)
 - v) Accelerate
 - vi) Decelerate
 - vii) Parameter setting

3.5 Application programming

The AC Drive shall be designed for both simple and the most complicated applications, yet it shall be user friendly. It shall be possible to reset the parameter settings back to the original factory settings through the keypad.

3.6 PC Tools

The AC Drive Supplier shall have Windows based PC software available for monitoring and controlling the AC Drives, and the software shall be offered as an option. The software shall be supplied with the necessary hardware and a provision for connecting a PC with the AC Drives. It shall be possible to set and modify parameters, control the drive, read actual values and make trend analysis using the software.

4.0 Software features

A. Restart

In the event of a fault trip due to over voltage, over current or loss of analogue signal, the AC DRIVE shall be programmable to attempt an automatic restart. For safety reasons, the maximum number of attempts shall be within a selectable time. If the fault does not clear after the attempts, the drive shall lock out.

B. Brake logic control

The AC Drive shall have a built-in function to control a mechanical brake in order to move the load in a

	CLIENT – OIL & NATURAL GAS CORPORATION (ONGC) PROJECT: 1 X 51 MW CCCPP, HAZIRA, GUJARAT - 66 KV GIS CONSULTANT- FICHTNER CONSULTING ENGINEERS (INDIA) PVT. LTD. TECHNICAL SPECIFICATION FOR EOT CRANE	TB-383-563-033
		Rev. 0
		Page 11

smooth and safe way. The brake logic control shall be adapted to the different movements: hoisting, travel, orientation.

5. Preferred makes:

Schneider Electric, L&T-YASKAWA, Siemens, ABB, Allen Bradley (Rockwell Automation).



ANNEXURE II

MAKES OF IMPORTANT ITEMS / COMPONENTS OF EQUIPMENTS AND THEIR DETAILS

MAKES OF SUB VENDORS ITEMS

S.N.	ITEM	MAKES
1	STEEL	SAIL/IISCO/TISCO/ JINDAL
2	HOOKS	MOOZUMDAR / KARACHIWALA/ SIMRITI FORGING / HARMAN MOHTA / Steel Forging & Engg. Co., Kolkata
3	GEAR COUPLINGS	ALLIANCE / HICLIFF / OEM
4	WIRE ROPE	USHA MARTIN BLACK / BOMBAY WIRE ROPES / UNITED WIRE ROPE / Bharat wire rope
5	BEARINGS	SKF/ FAG/ TATA/ NORMA / NBC
6	MOTORS	SIEMENS /NGEF/ CROMPTON /KIRLOSKAR / BHARAT BIJLI / ALSTHOM / ABB
7	BRAKES	ELECTROMAG /SPEED-O- CONTROL / EMCO LENZE
8	CONTACTOR	SIEMENS / L&T /TELE MECHANIQUE / BCH
9	OVER LOAD RELAYS	SIEMENS / L&T / TELE MACHANIQUE / ABB
10	HRC FUSES	SIEMENS / L&T/ GEPC/ L&T
11	ISOLATING SWITCH	SIEMENS/ L&T / GEC A / CONTROL & SWITCH GEAR
12	SWITCH FUSE UNITS	SIEMENS/ L&T/ CONTROL/ & SWITCH GEAR/ GEC A
13	TIME DELAY RELAYS	SIEMENS/ L&T/ ABB/ BCH/ GEC A / TELEMECHANIQUE
14	TRANSFORMERS	INDCOIL / LOGICSTAT / PRAGATI / PRAYOG KAPPA / SOTHERN ELECTRIC / AUTOMATIC ELECTRIC / PRECISE ELECTRICALS / SILKAAN
15	BULB & FLOURESCENT TUBES/FITTINGS	PHILIPS/ BAJAJ/ CROMPTON
16	CABLE LUGS (HEAVY DUTY)	DOWELLS / UML ENGINEERING
17	HOOTERS	BEACON / OSC/TARGET / KHERAJ
18	LIGHTING SWITCHES	ANCHOR / ELLORA
19	CABLES	
a)	POWER CABLES	NICCO / UNIVERSAL / INCAB / FORT GLOSTER TORRENT / CCI / ICL / RADIANT
b)	CONTROL CABLES	NICCO / UNIVERSAL / INCAB / FORT GLOSTER / DELTON / FINOLEX / TORRENT / CCI / ICL / RADIANT
c)	TRAILING CABLES	NICCO / UNIVERSAL / INCAB / ICL
20	CABLE GLAND	COMMET / SUNIL&CO. / ALLIED TRADERS / ARUP ENGINEERING / ELECTROMAC INDUSTRIES



CLIENT – OIL & NATURAL GAS CORPORATION (ONGC)
PROJECT: 1 X 51 MW CCCPP, HAZIRA, GUJARAT - 66 KV GIS
CONSULTANT- FICHTNER CONSULTING ENGINEERS (INDIA) PVT. LTD.
TECHNICAL SPECIFICATION FOR EOT CRANE

TB-383-563-033

Rev. 0

Page | 13

21	PUSH BUTTONS	SIEMENS / L&T / BCH
22	LIMIT SWITCHES	SPEED-O-CONTROL / ELECTROMAG
23	MASTER CONTROLER	SPEED-O-CONTROL / ELECTROMAG
24	SAFETY SWITCHES	ALSTOM / L&T / SIEMENS
25	PENDENT PUSH BUTTON STATION	OEM
26	INDICATING LAMPS	TECKNIC / BCH / SIEMENS / STANDARD
27	MCB	MDS / INDO COPP / STANDARD
28	PANELS	OEM
29	RESISTANCE BOXES	OEM
31	INSULATORS & COPPER CONDUCTORS	BHEL APPROVED MAKE
32	CASTINGS	KOLHAPUR STEEL / GNAT FOUNDRY / KIRTI ALLOYS
33	FIRE EXTINGUSHER	BIS APPROVED MAKES
34	VVVF DRIVE	YASKAWA (L&T)/ ABB / SIEMENS / SCHNIEDER
35	SHROUDED DSL	SUSHEEL / STROMAG



ANNEXURE-III

Procedure for Load/Overload testing of Single Girder EOT cranes at Manufacturer's Works

Objective: To demonstrate final No load / Load / Overload / Deflection / Functional tests of assembled Crane for the purpose of acceptance.

Basic Assumptions / Inputs for testing at Works:

- Actual job hook shall be used for Load / Overload tests for hoisting. However load / overload test for cross travel shall be done with hook block (without hook).
- Standard wire ropes (Equivalent to actual rope) shall be used for load / overload testing.
- Shop cables shall be used for temporary connection for the purpose of showing various functional tests at shop.
- Interlock and limit switch operation check will be shown without load for hoisting and CT motion.

Procedure for Load / Overload testing:

- The cranes shall be tested for NO load and load test at works generally in conformance with the IS – 3177 (1999). Specifically with respect to the load / overload testing of crane, the following tests as per the outlined procedures shall be done at works.
- Deflection of the girder will be measured at SWL when the trolley with load is at the middle of the girder.
- No load and full load current of the motors will be measured to verify whether it is as per the approved data sheet of the motor. Resistors in the circuit will be checked for any overheating of the element.

Hoisting & Cross Travel motions:

- The load will be gradually raised to 125 percent of the rated capacity (SWL) with actual hook. The load will be lifted upward to about 1 meter height above its support and stop again. Check for any undue drift in the load. If load drifts, check the adjustment of brakes and repeat the above procedure. Then lower the load to rest on support/ground.



Mandatory Spares:

Following mandatory repairs shall be supplied by the vendor inline with specification:

Sl. No.	Item	Qty
1.	Set of brake lining with rivets of each brake of crane	1 set
2.	For main and auxiliary hoist (both EM & EM thrustor)	1 set
3.	Oil seal sets for gear boxes of each cranes	1 set
4.	Brake springs for main hoist, auxiliary hoist, CT & LT of each crane	1 set
5.	Carbon brushes and brush holder of each motor of crane	1 set
6.	Solenoid Coil for EM brakes of each motor (Main hoist, AH, CT & LT)	1 set
7.	Complete set of fuse links required for each crane	1 set
8.	Overload relays for all motors of each crane	1 set
9.	Limit switches for all motions of each crane	1 set



SECTION - 2

EQUIPMENT SPECIFICATION

2.0 CODES AND STANDARDS

This EOT Crane shall be designed as indicated below:

The equipment to be supplied under this specification shall conform to the following codes and standards (latest revisions) unless otherwise specified hereinafter.

IS 807: 1976	Codes of Practice for Design, Manufacture, Erection and Testing (Structural Portion) of cranes and hoists.
IS: 3177 (1999)	Code of Practice for Design of Overhead Travelling Cranes and Gantry Cranes other than steel work cranes.
IS: 2266	Specification for steel wire ropes for general Engineering purposes.
IS: 4029	Guide for testing induction motor (for temperature rise)
IS: 15560	Steel hooks for standard shank design
IS: 1554 Part I	PVC insulated (Heavy-duty) electric cables for working voltages up to and including 1100 volts.
IS: 325	Three phase induction motors.
IS: 900	Code of practice for installation and maintenance of induction motors
IS: 694 (Part-I)	Copper conductors PVC insulated cables for voltage up to 1000 V.
IS: 434 (Pt I)	Copper conductors rubber insulated cables for voltage up to 1000V.
IS: 691	Flexible trailing cables rubber insulated.
IS 3043	Code of practice earthing.
IS: 3938	Electric Wire Rope Hoists.
IS: 2147	Degree of protection provided by enclosures for Low voltage switchgear and control gear.
IS: 1544	Polyethylene insulated PVC sheathed cables.

2.1 GENERAL DESIGN AND CONSTRUCTIONAL REQUIREMENT

- The crane shall be designed in accordance with the latest edition of IS-3177/IS-807 & hoist block shall be as per IS-3938 and any other standard as referred there in and subject to any modification and requirement as specified herein after.
Class of crane mechanism shall correspond to that of the crane requirement and as specified elsewhere.
- Safety devices should be provided with all equipment/parts covered under this specification.
- Parts requiring replacement or lubrication shall easily be accessible without dismantling the other equipment or structures. All electrical cables shall be laid to comply with recognized standards and purchaser's requirements.
- For welded construction such as bridge girders, end carriages, rope drum, gearboxes etc; steel shall be conforming to IS-2062 quality.
- No cast iron part shall be used on the crane except electrical equipment. However, in case of gear boxes only use of cast iron of grade not less than 25, IS: 210 - 1962 is recommended.
- Guard shall be provided on crane to prevent the hoist ropes coming in contact with down shop leads.
- Guards of an approved design, which will push forward or off the track any object such as a person foot or arm,



placed across it. Guards shall be attached to each end of the end carriages.

- h. Suitable guards shall be provided to revolving shafts, coupling etc.
- i. All cables shall be clamped individually. All trailing cables shall be clamped with PVC or non-metallic clamp.
- j. All wheels, couplings, open gear etc. shall be provided with covers.
- k. All bolts except those with locknut shall be provided with grid lock nuts or spring washers.
- l. Fasteners for pedestal blocks, motors, gearboxes etc. shall be easily removable from the top. Studs shall not be used as fasteners for mechanical items except for fixing covers.
- m. Defects in the material like fractures, cracks, blowholes, pitting etc. are not allowed. Rectification of any such flaw is permissible only with the approval of the purchaser.
- n. All parts of the crane shall be thoroughly cleaned of mill scales, rust or foreign matter and then painted as per the specification requirements.

The crane shall be manufactured as per the tolerances specified below

- a) Span over LT wheels $\pm 3\text{mm}$
- b) Diagonal on wheels $\pm 3\text{mm}$
- c) Long travel wheel alignment $\pm 1\text{mm}$
- d) Tilt of wheels or balancer axle $\pm 1/1000\text{mm}$ (horizontal and vertical)
- o. Permissible variation in Speeds at full notch with rated load, voltage and frequency shall be as follows.
 - i) Travelling and traversing $\pm 10\%$
 - ii) Hoisting Lowering $\pm 10\%$

3.1 STRUCTURAL DETAILS

- a. Crane structure shall be designed in accordance with the latest edition of IS-807 after taking the following additions/deviations as applicable.
- b. Black bolts shall not be used in the main structure of the crane. The calculated strength of other bolted joints in structural members shall not be less than net strength of member plus 25%.
- c. The calculated strength of riveted joint or joints made by friction grip bolts in structure members shall be not less than the calculated net strength of the member.
- d. Bolts used in shear shall be fitted in to reamed hole.
- e. Transverse filled welding on load carrying member shall be avoided.
- f. All butt welds on structural members subjected to tensile stress shall be X - rayed.
- g. Fillet welding on load carrying members shall be avoided.
- h. Plates, angles and other rolled section used in the load bearing members of the structure shall not be less than 6 mm thick.
- i. Minimum thickness of chequered plates for platform shall be over 5mm over plain. Chequered plates shall not be considered for strength calculations of load carrying member.
- j. The material of construction of the major components will be as specified in the specification/data sheet.

3.1.1 Girder / Beam

- 3.1.1.1 The girder / beam shall consist of a box construction with double web plate girders or lattice girders or rolled steel section and shall be of adequate strength to withstand the rolling loads and other stresses it is subjected to. The design of the girder shall be in accordance with latest edition of IS- 807 with the following deletion /



addition as applicable.

3.1.1.2 Minimum deflection of the bridge girder with safe working load shall not exceed 1/900 of span or as specified in the specification keeping trolley stationed at the middle of span and excluding the deflection due to dead load. The girder shall be cambered by an amount equal to the maximum deflection due to dead load plus one half the live load and trolley.

3.1.2 End carriage

3.1.2.1 End carriages shall be fabricated from rolled steel section or plates or as the case may be. End carriage shall be of ample strength to resist all stresses likely to be imposed on them under service conditions including collision with other cranes or stops.

3.2.0 MECHANICAL

3.2.1 Rope drums

Rope drums shall be of mild steel plate fabricated or of cast steel as the case may be. All fabricated rope drums shall be stress relieved. The drum shall be so designed to take full length of hoisting rope in single layers. The end of the rope shall be anchored to the drum in such a way that the charger is readily accessible. Each rope shall have not less than two (2) full turns on the drum when the hook is at lowest position not taking into consideration the turns covered by the rope in charge. There shall be one spare groove for each rope lead when the hook is at the highest position. Each rope end shall be clamped with minimum two clamping wedges with at least two bolts on each clamping arrangement.

The pitch diameter of the drum shall be as per IS - 3177 or as specified elsewhere. The depth of the groove shall not be less than 0.35 times the rope diameter. Each rope shall be clamped to drum with two clamp wedges with at least two numbers of bolts on each clamping arrangement.

3.2.2 Hoist ropes

Ropes of fibre /steel core as specified in Data Sheet - A shall be of right hand lay, 6x37 or 6x36 construction of best plough steel having minimum tensile strength as 160-175 kg/mm². Left hand lay wire ropes shall not be used (Reverse bend ropes shall be avoided as far as possible).

The load-bearing capacity of the ropes and shackles must be suitable for the relevant hoist.

The maximum tension in the rope must not exceed 1/8 of the calculated breaking capacity of the rope. The ropes must be of the stranded type, and galvanized wires must be used.

The eyes of the single ropes must be secured with compression fittings. The length of the eyes must be at least 15 times the nominal diameter of the rope.

3.2.3 Rope sheaves

Sheaves shall be of cast or forged steel. All sheaves shall be identical; however, exception may be made for equalizer sheave. Sheave groove shall be ground finished for getting increased rope life. Equalizer sheave shall be arranged to turn and swivel in order to maintain rope alignment under all circumstances.

3.2.4 Wheels

LT wheels shall be single flanged with straight tread to suit the mono wheel beam. The wheels shall be capable of taking up misalignment in span as specified. Solid wheel shall either be of forged steel or as specified. The wheel shall be with minimum hardness of BHN 300-350. Contact stresses between wheels and rails should be



within permissible limits.

3.2.5 Buffer

Each End carriage shall be provided with buffer as per data sheet 'A'. Buffers should be so located that removal is not required while changing wheels or bogies. Buffers shall have sufficient tension on energy absorption capacity to bring the unloaded crane to rest from the speed of 40% of the rated speed to zero speed

3.2.6 LT drive

One pair of wheels in each end carriage shall be driven by motor through reduction gear.

3.2.7 CT drive

The CT mechanism of the electric hoist shall consist of 2 pairs of wheels and a pair, which shall be driven by motor through reduction gear.

3.2.8 Gearing

Spur and helical gearing shall normally be used for all motions. Worms and bevel gears shall not be used. First high-speed reduction shall be through helical gears. All gears shall be hardened and tempered and of alloy steel with machine cut teeth. Surface hardening of teeth is not acceptable. Gear teeth shall preferably be cut in metric module system. Gears shall be designed to meet requirement of crane duty as per IS: 3177. The ratings of gears shall be established as per IS: 4660.

3.2.9 Gear Box

3.2.9.1 All gears shall be completely covered and enclosed in oil tight casing & sealed with gasket.

3.2.9.2 The gearboxes shall be of mild steel or cast steel. All fabricated gearboxes shall be stress relieved.

3.2.10 Bearing

3.2.10.1 Ball and roller antifriction bearing of FAG, SKF, NBC, NORMA, make shall be used throughout, except where specified otherwise. Rated life of ball and roller bearing shall be not less than total working life as per relevant Codes IS-3177. Life of bearing shall be calculated in accordance with manufacturer's recommendations.

3.2.10.2 Provision shall be made for service lubrication of all bearings. Bearing enclosures shall be designed as far as possible to exclude dirt and prevent oil leakage.

3.2.11. Couplings

Motor shafts shall be connected to gear box input extension shafts through flexible gear coupling. Solid coupling shall be used for connecting intermediate lengths of long travel shafts, if applicable.

3.2.12 Lifting hook

Standard hooks shall be used unless otherwise specified. These hooks shall conform to the latest edition of IS 3815 or specified in the data sheet "A".

3.2.13 Brakes

Selection and design of brakes shall be such as to meet the requirement. Electro mechanical / hydraulic brakes shall be provided for each motion. Brakes shall be designed to suit 200% FLT of motor for the hoist motion and 150% FLT of motor for LT & CT motion. Brakes shall be provided as specified in Data Sheet 'A'.



3.3.0 ELECTRICAL

3.3.1 The scope of supply shall cover all electrical equipment comprising from Main isolating switch, down shop leads, trolley conductors, current collectors etc.

3.3.1.1 Main isolating Switch fuse unit shall be provided at 1.5M above the operating floor level at one end of bay length or in the middle as specified in the data sheet A. Termination of incoming power supplies cable to isolating switch fuse unit and further cable from switch to down shop leads shall be included in the bidder's scope of work. The switch shall be provided with Power ON Red indication lamp.

3.3.1.2 Run way conductors (Down shop leads) shrouded conductor or M.S. Angle type as specified in the data sheet A shall have four conductors. One of the conductors shall be connected to earth grid for earthing connections of all electrical equipment on the crane and shall be connected to suitable collecting gear of earth conductor. Voltage drop across the down shop leads shall be less than 2%. If MS angle sections are used as runway conductor, then current density shall not be 0.42 Amp/ Sq. mm. It shall be supplied with brackets. Maintenance cradle for DSL shall be provided on crane if asked in Data Sheet 'A'. Sufficient allowance of min. 10% for wear & tear shall be considered while sizing the conductor. The runway conductors shall be supported on brackets and insulators.

3.3.1.3 The current collectors shall be of cast iron type with adequate current carrying capacity and shall maintain adequate contact pressure. Spacing between current collectors shall be such as to provide sufficient quenching area for sparks coming out of collector's surface. The collector system per conductor shall be top-running type having spring loaded CI/carbon metallic shoes to maintain adequate contact pressure.

3.3.1.4 The cable, supplying power to crane trolley / electric hoist shall be flexible trailing cable as per IS-9968 Part-I (latest edition) and mounted on retracting supports (festoon type)

3.3.2 DRIVE MOTORS

3.3.2.1 Crane Motors shall be totally enclosed, fan cooled and as per data sheet 'A'. The starting torque of motor shall not be less than 2.25 times the rated torque and pull out torque shall not be less than 250% of the rated full load torque of motor.

3.3.2.2 Ambient correction factors as well as voltage /frequency correction factors depending upon the ambient temperature and voltage /frequency variation shall be applied to derate the motors. The minimum margin of 15% or as specified in the section C of specification shall be considered over the calculated rating of the motor. The protection class of the motors shall be as per data sheet A. Motors shall be tested at manufacturer's works in accordance with IS 12615 & IS/IEC 60034/as per agreed Quality plan & Reports shall be submitted for approval. Motors shall comply with the requirement of IS 12615 & IS/IEC 60034 or as per the motor specification if enclosed here with.

3.3.2.3 All the motors shall be provided with lifting lugs two earth terminals of adequate size to accept the earthing conductors shall be provided at diametrically opposite points unless specifically designed for higher speeds, motors shall be capable of withstanding 2.5 times the rated speed.

3.3.3 Limit Switch

The hoist mechanism of the crane shall be provided with rotary type limit switch to open the control circuit and in order to prevent the crane hook from over hoisting and over lowering. One gravity type back-up limit switch of hand-reset type shall be provided. This switch shall operate in the event of failure of main limit switch if



called for in data sheet "A".

Lever operated limit switches shall be provided at both ends of longitude travel and cross traverse. These limit switches shall be self-reset type.

3.3.4 Protective Panel / Controls

3.3.4.1 The electrical protective panel shall be a cubicle fabricated from 2 mm thick sheet steel with lockable-hinged door. It shall be dust and vermin proof with degree of protection as IP-54 or as specified in data sheet A. All the equipment inside the panel shall have permanent identification. The panels shall be front connected type with front-hinged door for access to wiring and terminals. Engraved nameplate shall be furnished for all panels and also for the equipment and devices mounted there on.

The following minimum equipment shall be provided.

- a) One triple pole air break type main contactor with thermal overload relay.
- b) One triple pole main line connecting/disconnecting switch.
- c) Switch fuse unit with D.O.L. starter for each motion.
- d) Thermal overload relay for each drive. It shall be ambient temperature compensated and adjustable type.
- e) Contactors, timer and auxiliary contactors.
- f) Control transformer with fuses.
- g) Indicating lamps to indicate the live condition of all three phases.
- h) Other equipment as per supplier's standard practice. Air break contactors shall conform to category AC-4 duty. The main contacts shall have the rating for 5 Amps or as specified in the data sheet A. The contactor drop off voltage shall be between 45-50% of rated voltage.
- i) All internal wiring shall be identified with numbering ferrules at both ends as per the relevant wiring diagram.

3.3.5 Pendant Push button station

It shall be suspended by wire rope to prevent pull on the cables. The following minimum push buttons key operated type or as specified in the specification shall be provided.

- a) Main "ON", "OFF" push button key operated and lockable in "OFF" position. This push button will operate the main contactor.
- b) Hoist and lower directions. (2Nos.)
- c) Trolley travels both directions. (2Nos.)
- d) Bridge travels both directions. (2Nos.)
- e) Inching speed for hoisting & lowering.
- f) Inching speed for bridge motion.
- g) Inching speed for trolley motion.
- h) Creep speeds (specified in Data Sheet-A)
- i) Emergency stop push button.
- j) Alarm bell push button.

3.3.6 Grounding

3.3.6.1 The crane structure, motor frame and all other electrical equipment shall be grounded in accordance with the Indian Electricity Rules. The connections from Crane Bridge to 4th conductor of down shop leads shall be by



means of current collector.

3.3.6.2 The equipment fed by flexible cables shall be grounded by means of fourth core provided in the flexible trailing cable. Pendant push button station shall be earthed separately.

3.3.6.3 Red warning light 3 Nos. shall be provided at both ends of the gantry girder to indicate the aliveness of DSL.

3.3.7 WIRING SYSTEM

- a) The supplier shall furnish all power, control and auxiliary circuit wiring of the equipment and the panel located on the trolley or bridge.
- b) The wiring shall be complete in all respect to ensure the proper functioning of the equipment.
- c) Power wiring to any motor shall be done with 1100V grade aluminium conductor, PVC insulated/ armored /FRLS cable of suitable sizes as specified in Data Sheet A.
- d) For selecting the cable rating, cable for power wiring, consideration shall be given to the motor duty, ambient temperature grouping and disposition of the cables voltage drop etc.
- e) All control and auxiliary external circuit wiring shall be done with PVC insulated FRLS type 2.5mm stranded copper conductor.
- f) Armoured cables or un-armoured running through the flexible conduits may be used for power wiring / control and auxiliary circuit wiring shall run through flexible conduits.
- g) Each motor shall be wired independently. Power and control wiring shall be effectively separated.
- h) Each wire shall be identified at both ends with wire designation in accordance with circuit wiring diagram.
- i) All wire termination to the panels shall be provided with clamp type connections screw. Type terminals with screw directly impinging on conductors are not acceptable.
- j) Multi-way terminal blocks complete with screw nut, washer and marking strips shall be furnished for terminating the panel wiring and outgoing.
- k) Not more than two wires shall be connected to any terminal on either side of terminal block. If necessary number of terminals shall be jumped together to provide the wiring points.
- l) Each terminal block shall be marked with designation in accordance with conductors wiring diagram.

Safety arrangements for short circuit, under voltage and single phase protection shall be considered for design requirement in addition to manufacturer's standard to prevent damage to motors on account of overload and electrical faults and to gearing shafts, etc. due to over stressing.

4.1. Design Criteria - Steel Structures

Framing

All steel framed structures shall generally be of rigid frame in the generally transverse direction and braced frame in the longitudinal direction with bracing confined to selected bays.

Lateral forces shall be resisted by stiff jointed moment connections in rigid frame design. The column bases shall generally be fixed to concrete pedestal / column by providing moment resistant base detail.

Design Methodology

The design of steel structures shall be done by working stress method in accordance with the provisions of IS: 800 and other relevant IS codes as applicable to specific structures.



Crane gantry girders shall be a rolled section with flange plate and or welded construction with bearing and intermediate stiffeners. Crane girder shall be designed as simply supported and of single span length.

Permissible stresses for different members shall be allowed to exceed by 33-1/3% under wind and seismic conditions. However, permissible stresses in bolts and welds shall be allowed to exceed up to 25% only.

For design which requires the use of the minimum column load (such as, uplift on anchor bolts, column axial tension etc.) 90% of Dead Load along with uplift forces if applicable shall be considered.

Base plates shall be placed on foundation pedestal with grouting. For large base plates necessary grout holes shall be provided. Generally anchor bolts for fastening steel columns on foundation shall be embedded in foundation during concreting itself using suitable templates for correct positioning.

No anchor pockets in foundation shall be allowed for anchor bolts in tension. Design of base plates shall be based on design pressure on foundation, which shall not exceed the appropriate bearing values given in IS: 456.

The total horizontal shear force at the base of column is transferred to the column pedestals through friction between the base plate and the grout. A co-efficient of friction of 0.30 shall be used in conjunction with the minimum column load, as defined above. If the horizontal shear force exceeds the frictional resistance force shear may be transmitted through bolts or shear keys. If the column is subjected to a net uplift load, the total force shall then be transmitted through shear bars / shear keys welded to the base plate. Necessary recesses shall be kept in the foundation concrete for shear lugs.

Minimum height of the encasing of structural columns shall be 300 mm to 500 mm.

Angle sections shall not be used as flexural members except for roof trusses, purlins, side girts and walkway runners.

For axially loaded members in framework, minimum angle section to be used shall be ISA 50x 50 x 6.

End connections for rolled beams, built-up beams etc. shall be designed for a minimum of 75% of their shear capacity and 100% of moment capacity (for moment connection).

Moments shall be considered for design of columns arising due to eccentricity of floor beam connections with column. Minimum eccentricities on column shall be considered as per IS: 800. For edge protection all-round cut-outs / openings in floor slabs. Minimum angle section to be used shall be ISA 50 x 50 x 6 with suitable anchor lugs.

Toe guards shall have a minimum depth of 100 mm and a minimum thickness of 6 mm. Hand railing shall be of hot dip galvanized construction out of 40 mm NB pipes of medium class conforming to IS: 1161 with threaded ends and necessary bends, tees, elbows, sockets etc. Hand railing shall be 1000 mm high with two horizontal rails one at 500 mm and another at 1000 mm above the base level along with vertical posts spaced at not more than 1500 mm centers.

Where floor beams form part of the vertical bracing system, additional loads from floor beams transferred to bracing shall be taken into consideration in the design.

Minimum width of steel staircase shall be 1000 mm. Minimum width of treads without nosing shall be 250 mm. Maximum height of riser shall be 200 mm and they shall be limited to 16 per flight.

Staircases shall be provided with hand railing. Staircase step shall be made out of chequered plate or gratings of press welded construction designed for a live load of 500 Kg/ Sq. m.

For any structural steel member, a minimum of 2 nos. 16 mm dia black bolts shall be used for permanent



bolted connection and 1 no. 16 mm dia erection bolt for site welded connections.

All foundations bolts shall be provided with one nut and one locknut.

Base plate arrangements of all structural steel columns in buildings shall be so provided that the entire base assembly is below finished floor level. The base plate assembly shall be suitably encased in RCC. For open structures, base plate shall be rest on RCC pedestals, which are 300 mm above finished ground level.

All grouting work below stanchions / bases of equipment shall be with, branded premixed non-shrink free flow grout of approved manufacture which shall have a minimum crushing strength of 450 Kg/cm. Sq. at 28 days.

Minimum thickness of colour coated GI sheets to be provided as roofing and cladding shall be 0.5 mm
Minimum slope of colour coated GI sheet roofs shall be 10 degrees.

Materials

Structural steel shall conform to IS: 2062.

Chequered plates shall conform to IS: 3502. Pipes for handrail shall be as per medium grade of IS: 1161.

Crane rails and transformer track rails shall conform to IS: 3443.

Connections

Generally all shop and field connections shall be welded except for field connections. All moment connections, if bolted shall be of High strength friction grip bolts. Shear and other minor connections, if bolted may be made with mild Steel / High strength bearing bolts.

IS: 816 and IS: 9595 shall be followed for welding of structures. Electrodes of approved makes shall be used.

For high strength friction grip (HSFG) bolt connections, IS: 4000 shall be followed. High strength friction grip bolts shall be of property class 8.8 and shall conform to IS: 3757 and shall not be less than 20 mm in diameter. High strength bolts shall be installed as bearing type joint except where loads are reversible.

All other (other than HSFG) bolted connections shall have bolts of minimum 16 mm dia. The connections of stairs and hand railing shall be made with 16 mm diameter threaded fasteners conforming to IS: 1363. Erection bolts shall be black bolts of minimum 16 mm dia.

All bolts and nuts have property class compatible to each other. Bolts carrying dynamic or fluctuating loads and those in direct tension shall be provided with an additional double coil helical spring washer conforming to IS: 6755.

Where a steel beam or member is to be connected on RCC structure, it shall be connected using an insert plate and preferably through shear connection.

For crane girders, full penetration of weld between web plate and top flange shall be ensured.

The working point of the bracing connection shall be the center of column and girder to which it connects, where practical. The connections of gusset plates to column and girders shall be made to include provisions for eccentricity in connection. The double angle back-to-back with gusset plates in between shall not be used in dust-laden areas. Where double angles are not adequate, beam sections with web in the plane of bracing are to be used.

Horizontal bracings shall be angle / tee section located at the bottom of framing beams. Field welding of bracing at the underside of beam as required to meet slenderness requirement of bracing member shall be indicated on the drawings. Horizontal bracing shall be arranged to avoid framing into the beams at columns



locations.

Intermittent welding shall not be permitted.

Permissible Deflections

The permissible deflection of various steel members under normal loading conditions shall be as specified below. For calculation of deflections in structures and individual members dynamic effects shall not be considered, unless specified otherwise. Also, no increase in deflection limits shall be allowed when wind or seismic loads are acting concurrent with normal loading conditions.

Vertical Deflection

Beam and Girders: Span / 325 or 20 mm whichever is lesser.

For crane gantries or any member subjected to working loads, the maximum deflection under dead load and live load excluding impact shall not exceed the following values:

For manually operated cranes & Monorail: Span / 500

For EOT Cranes < 50T: Span / 750

Horizontal deflections

Columns: 1/325 of height

Crane Supporting Columns: 1/1000 of height for horizontal surge load.

The maximum horizontal relative displacement due to seismic forces between two successive floors shall not exceed 0.004 times the difference in level between these floors.

Minimum Thickness

The minimum thickness of various components of a structure and hot rolled sections shall be as follows. The minimum thickness of rolled shapes shall mean flange thickness regardless of web thickness. Structural steel members exposed to marked corrosive environment shall be increased suitably in thickness or suitably protected otherwise as per good practice and sound engineering judgment in each instance.

a. Trusses, purlins, girts and bracing: 6 mm

b. Columns and beams: 8 mm

c. Gussets: 8 mm

d. Stiffeners: 8 mm

e. Base plates: 10 mm & above

f. Chequered plates: 6 mm o/p & above

g. Grating flats: 5 mm

h. Minimum thickness of structural members, other than gratings and chequered plate, directly exposed, to weather and inaccessible for painting and maintenance shall be: 8 mm.

Minimum sizes

The flange width of purlins supporting roof sheeting and wall cladding shall not be less than 50 mm.

Width of steel rolled section connected to other member shall be at least 50 mm.

Slenderness and Depth Ratio

The slenderness ratio of main members in tension, compression or bending shall be in accordance with IS: 800.



The following limiting ratios of depth to span shall be considered as general guide.

- a. Truss 1/10
- b. Rolled beams and girders for ordinary 1/24 floors and rafters
- c. Supporting floor beams for vibrating 1/15 machinery / equipment
- d. Roof purlins and girts 1/45
- e. Gable columns 1/30

Painting and Corrosion Protection Measures

Structural steel shall be painted after sand blasting as per specification.

For galvanized structures, rate of zinc coating shall be not less than 0.710 kg/m², unless mentioned



SECTION - 3

PROJECT DETAILS GENERAL TECHNICAL REQUIREMENTS

SL.NO.	DESCRIPTION	
1.	PROJECT INFORMATION	
	a) Customer	ONGC Ltd.
	b) Consultant	FICHTNER Consulting Engineers (India) Pvt. Ltd.
	b) Project	66 KV GIS system for 1 X 51 MW CCCPP for ONGC , Hazira
1.0	Location	ONGC Limited, Hazira
2.0	Elevation above mean sea level	RL 6.0 above, MSL
3.0	Nearest Railway Station	Surat, 20 KM
4.0	Nearest Airport	Surat, 10 KM
5.0	Nearest Harbour	Magdalla, 20 KM
6.0	Access Road	NH-8 (30 KM)
7.0	Atmospheric pressure at MSL	1.013 bar
8.0	Ambient Temperature	
a)	Max. average dry bulb temperature	45.6 oC
b)	Min. average dry bulb temperature	4.4 oC
c)	Design temperature for electrical equipment / device	50 oC
9.0	Relative Humidity	
a)	Max.	70%
b)	Min.	18%
c)	Average	64%
10.0	Seismic Zone	III (IS 1893)
11.0	Rainfall	
a)	Max. Intensity of rainfall in 24 hrs.	459.2 mm
b)	Period – Monsoon showers	June to September
c)	Average rainfall per annum	1203.5 mm
12.0	Wind data	
	Max. wind speed (as per IS:875) 20-61 kmph for 20 days in a year < 20 kmph for remaining period	62 kmph
	Most predominant wind direction	South -West
13.0	Land	
14.0	Tropicalisation	
	All equipment supplied against specification shall be given tropical and fungicidal treatment in view of the climatic conditions prevailing at site.	
	Tropical protection shall conform to BS: CP-1014-1965 "Protection of Electrical Power Equipment" against climatic conditions.	



Auxiliary Supply

Normal Voltage	Variation Voltage	in	Frequency in Hz	Phase/Wire	Neutral Connection
415 Volts	± 10%		50 +3% to -5%	3 phase/ 4 wires	Solidly earthed
240 Volts	± 10%		50 +3% to -5%	1 phase/ 2 wires	One point earthed
110 Volts DC	± 10%		DC	1 phase/ 2 wires	Isolated 2 wire system

2. General electrical requirement as per Vol III, Section 3.1 of ONGC specification.(4 pages) (enclosed)

The discharge of pollution in water and air as well as noise levels shall meet with the stipulations of State Pollution Control Board as well as other Acts of the Government under the Ministry of Environment and Forestry. It is a pre-condition that irrespective of what is stated in statutory regulations or any other act or norms, the Specification stipulated environmental qualities standards are the minimum requirements and shall be fulfilled in all aspects.

For control room and offices, noise level shall not exceed 60 dB (A) near to the duct and at other places in the control room/offices noise levels shall not exceed 50 dB (A).

Equipment supplied and all work done including system design and detailed engineering shall also comply with the statutory requirements of the State/Central government and with the Indian Electricity Rules.

Unless otherwise specified, at least 10 % margin shall be considered in equipment sizing over and above the calculated load current/fault current/power requirements.

If not specified otherwise the electrical operational equipment must be designed to meet protection classes stated below.

- HT Switchgear (Indoor) - IP 4X
- LT Switchgear (Indoor) - IP 52
- Control panels (Indoor) - IP 42
- Relay panel - IP 42
- Motors (indoor) - IP 54
- Motors and other equipment located outdoor - IP 55
- Emergency DG (Indoor) - IP 23

Each individual enclosure accommodating electrical equipment which is liable to suffer from internal condensation due to atmospheric or load variations shall be fitted with heating

3. Standards and Codes of Practice

All equipment, systems and works covered under these specifications shall be in accordance with all the applicable statutes, regulations, codes and standard specified as well as all such standards, statutes, regulations and safety codes applicable in the locality where the equipment will be installed. Contractor may familiarize themselves with all such requirements.

Complete design including pressure parts, piping, valves and fittings shall meet or exceed all the latest requirements of the Indian Boiler Regulations (IBR), latest Indian Standards /ASME codes, latest codes and standards as applicable. Any Indian/International standards shall be followed for any imported equipment. For plant layout aspects and area classification requirements OISD standards shall be followed.

The design, construction and testing of all equipment, facilities, components and systems shall be in accordance with relevant standards and codes issued by Bureau of Indian Standards (BIS) and/or reputed



international standards and codes as on the date of Award of Contract. A non-exhaustive list of reputed international standards is given below:

- a) American National Standards Institute (ANSI)
- b) American Petroleum Institute (API)
- c) American Society of Mechanical Engineers (ASME)
- d) American Society of Testing and Materials (ASTM)
- e) American Water Works Association (AWWA)
- f) American Welding Society (AWS)
- g) British Standards (BS)
- h) Cooling Technology Institute (CTI)
- i) Deutsches Institut für Normung (DIN), Germany
- j) Gosstandart of Russia (GOST) standards
- k) Heat Exchange Institute (HEI), USA
- l) Hydraulic Institute Standards (HIS), USA
- m) International Electro-technical Commission (IEC)
- n) Institute of Electrical and Electronics Engineers (IEEE)
- o) International Organisation for Standardisation (ISO)
- p) Japanese Industrial Standards (JIS)
- q) National Electric Code (NEC), USA
- r) National Electrical Manufacturers Association (NEMA), USA
- s) Central Electricity Authority (Construction of Electrical Plants and Electric Lines) Regulations, Notification, 20th August 2010 and to those referred therein
- t) National Fire Protection Association (NFPA), USA
- u) Occupational Safety and Health Administration (OSHA)
- v) Tubular Exchanger Manufacturers Association (TEMA), USA
- w) VDE association for Electrical, Electronic and Information Technologies (VDE), Germany
- x) OISD

Other international Standards, equivalent or superior to the above Standards can also be adopted. However, In the event of any conflict between the requirements of the international standards or codes and the requirements of the BIS standards or codes, the latter shall govern unless specified elsewhere in the specifications. Any Indian/International standards shall be followed for imported equipment.

The Plants and Electric Lines (within the plant) shall also be designed to comply with the requirements stipulated in.

- a. Central Electricity Authority (Installation and Operation of Meters) Regulations, 2006.
- b. Central Electricity Authority (Technical Standards for Connectivity to the Grid) Regulations, 2007.



- c. Central Electricity Authority (Measures relating to Safety and Electricity Supply), Regulations as and when these are notified by the Authority.
- d. Central Electricity Authority (Safety Requirements for Construction, Operation and Maintenance of Electrical Plants and Electric Lines) Regulations as and when these are notified by the Authority.
- e. Central Electricity Authority (Grid Standards) Regulations as and when these are notified by the Authority.
- f. Central Electricity Authority (Construction of Electrical Plants and Electric Lines)
- g. Regulations, Notification, 20th August 2010 and to those referred therein
- h. Indian Electricity Grid Code issued by Central Electricity Regulatory Commission (CERC) and
- i. Applicable State Grid Code issued by appropriate Regulatory Commission.

All material and equipment supplied and all work carried out as well as calculation sheets, drawings, quality and class of equipment, methods of inspection, constructional peculiarities of equipment and parts and acceptances of partial plants, as far as these are beyond the special requirements of the specifications, shall comply in every respect with the technical codes of the above listed codes and Standards.

American, British, German or other international standards established to be equivalent or superior to IS/ASME shall be acceptable with the approval of the Owner/Owner's representative at the time of detailed engineering.

Where there are no standards or regulations, or the standard is not sufficient to meet the need of design and supply, for such items relating to the power plant, the Contractor shall carry out the design, manufacture, supply and installation on the basis of good engineering practice.

During the period of Contract execution, if any standards change, the Contractor shall be responsible to notify the Owner/Owner's representative and provide the basis for the prospect that it would not cause the lowering of quality, performance and service life of the power plant due to alteration of the standard and the latest standards shall be followed by the Contractor.

Further requirements about applicable standards and codes are specified in the detailed technical specifications.

4. SPECIAL TOOLS, TACKLES AND EQUIPMENT

One set of special tools and tackles required unit for the operation, maintenance, inspection and repair of the individual main equipment and auxiliary equipment shall be supplied by the Contractors in sufficient quantity to equip the shift personnel, maintenance personnel and workshop craftsman for commissioning, testing, calibration, modification and maintenance of the unit, List of such special tools, tackles and equipment shall be submitted in the EPC bid.

Special tools and tackles excludes conventional ones and those locally available normally (not those requiring a drawing and considered as those made to order).

The special tools and equipment for maintenance and repair shall be delivered by the Contractor in lockable steel boxes and they shall be marked in an approved manner for identification purposes and a corresponding tool chart shall be supplied with the steel boxes.

The following tools and appliances shall be supplied under this Contract for use by the Owner/Owner's representative:



- 2 sets of special tools and gauges required for the maintenance of the Plant
- 1 set of special lifting and handling tackles / appliances required for the maintenance of the Plant.

The tools, tackles and appliances supplied in general, shall not be used for erection purposes by the Contractor and shall be handed over in brand new condition. Damaged tools, tackles, and appliances shall be replaced before handing over.

The exception to this is the special lifting gear which may be used provided that when it is handed over to the Owner/Owner's representative it has not been subjected to more than normal wear and is still fully suitable for its intended use.

Each set of tools, gauges and appliances under category (a) above shall be suitably arranged in fitted boxes of mild steel construction, the number of boxes being determined in relation to the layout of the plant and equipment in question.

If the weight of any box and its contents should be such that it cannot conveniently be carried, it shall be supported on steerable rubber-tyred wheels.

Each cabinet and box shall be painted, fitted with a lock and clearly marked in white letters with the name of the item of equipment for which the tools and appliances contained are intended.

Suitable storage racks shall be provided for all portable lifting tackle supplied under this contract.

Suitable lifting lugs, ears or ring bolts, or tapped holes for lifting rings shall be provided on all equipment items where the weight exceeds 15 kg.

All lifting tackle shall be stamped with a unique identification number and safe working load. A test certificate from an approved Authority shall be supplied for each item of lifting tackle.

The Contractor shall provide a schedule of all lifting tackle and tools and appliances being supplied, for the approval of the Owner/Owner's representative.

The Contractor shall provide all runway beams, trolleys, lifting blocks, special slings necessary for the safe and efficient handling and maintenance of the works. Particular attention shall be paid to handling of equipment located at higher elevations safety valves

The tools and appliances with the appropriate storage racks, cabinets and boxes shall be handed over to the Owner/Owner's representative at the time of Taking Over of the complete Plant.

Since the Contract includes site erection, any special tools or appliances required solely for erection shall be provided by the Contractor for his own use and shall remain the property of the Contractor.

Control and Instrumentation: Software with associated hardware required to access instruments or control systems to be provided.

5. INSPECTION, TESTING AND INSPECTION CERTIFICATE

Inspection testing shall be done as per BHEL/customer approved QAP.

6. DOCUMENTATION

Format of Documentation

All engineering documents and drawings shall be of international "A" series sizes, that is, A0, A1, A2, A3 and A4.

One set of CD containing all the drawings in Auto CAD (for final as built drawings) shall also be supplied in addition to hard copies.



Soft copy of all other documents shall be supplied in a CD in PDF or editable format. For review purpose pdf or editable version shall be considered.

Grouped documents shall be provided by size A4, with the inclusion of bigger size drawings which, however, have to be folded as Size A4.

Numbering and Identification of Documents

All the drawings shall be identified through a common way of numbering in accordance with the requirement of contracting. The numbering system of drawings and documents proposed by the Contractor shall be in compliance with the plant identification system and to be agreed with the Owner/Owner's representative. Apart from this, some drawings may also be numbered in the way which the contractor or subcontractors are used to do. But, there shall be a common title Block on all published drawings which include the following contents:

- Owner
- Owner's Engineer
- Project
- Contractor
- System
- Drawing No.
- Sheet No
- Revision No.

The measuring units and dimensions marked on the project engineering drawings shall be of SI system conforming to ISO 1000.

English words shall be used as descriptions on drawings.

In case dimensions are not marked in conformity with the scale of drawings and any dimension on the drawing does not conform to those dimensions and sizes measured through certain scale, the actual marked dimensions shall be applicable.

For revision of drawings, the revised part shall be clearly and definitely shown on the drawing.

For revision of documents which have been grouped together, a brief description shall be a perpendicular line with the margin of the revised copy closely following it.

Provision for Documents

Generally, copies of drawings or documents containing trade secret and drawings with patented nature need not be provided.

However, to know whether the Contractor has performed its obligations, the Owner/Owner's representative has the right to examine those drawings within the Contractor's working scope.

The Contractor shall meet the Owner/Owner's representative's reasonable demands to files and do the following to satisfy the Owner/Owner's representative:

- Contractor will work according to the requirements specified in the contract.
- Contractor's working has been arranged properly and developed according to the plan.
- The quality control system is reliable.
- After receiving all documents necessary for power plant operation and maintenance, Contractor shall supply equipment and systems.



- Having received all necessary documents for Contractor to perform its legal obligations or other relevant responsibilities.

Distribution of documents

The source, distribution, no. of copies shall be as per the following document distribution schedule. Annexure 4

Title block for the Project:

a) Customer	ONGC
b) Consultant:	FICHTNER Consulting Engineers (India) Pvt. Ltd.
c) Project:	66 KV GIS system for 1 X 51 MW CCCPP for ONGC , Hazira
d) Main Contractor	BHEL

DOCUMENTS TO BE SUBMITTED ALONGWITH OFFER

- 1) Drawings in 2D and 3D format.
- 2) Guaranteed Technical Particulars
- 3) Type Test Reports
- 4) Manufacturing Quality Plan

DOCUMENTATION SCHEDULE AT CONTRACT STAGE

No. of Copies	A: For Approval
5	Copies of GA drawings (2d and 3D) with projects details, dimension, equipment weight, fixing details, tolerances and terminal details etc.
5	Copies of type test reports
5	Copies of shipping list detailing the description & quantities of all items being dispatched separately, with shipping weights, number of cases and dimensions.
5	Copies of manufacturing and field quality plan.
5	Copies of installation, operation & Maintenance manual.
	B: After Approval and For Information/Distribution.
12	Copies of All drawings
12	Bound sets containing all drawings/manuals, type and routine test reports etc. along with sub-vendor's test reports for all bought out assemblies/components/parts including Internal wiring diagrams and exploded diagrams of assemblies/ parts, shall be furnished.
12	Copies of Installation, Operation & Maintenance manual.
	C: On Completion of Entire works
12	Bound sets of Installation, Operation & Maintenance manual and all as built drawings
12	Set of Computer CD-ROMs (with unbreakable CD Covers) containing all as-built drawings in Auto-Cad version 2008 or later with 2D and 3D drawings, Instruction Manual and GTP.



7. CLEANING, PROTECTIVE COATING AND PAINTING

Surface/Location	Temp.	Surface Prep	Paint System			Per Coat Microns (Dft)
			Coat	No. of Coats	Generic Type	
Structural steel work, cranes, steel floors, outdoor.	Upto 130°C	Sa 2 ^{1/2}	Prime	2	P6	35
			Intermediate	1	P7	100
			Finish	1	F2	50
					Total DFT	220

8. Package, storage

All materials and equipment should be packaged according to the typical environmental conditions during storage. In case of severe conditions, these materials and equipment should be packaged carefully by taking a full and appropriate preventive measure to protect from any damage or wear.

The Contractor and his appointed Subcontractor for installation should guarantee jointly that a good supplementary storage will be carried out within the equipment site controlled by them.

Three classes for storehouse are described as follows:

Storehouse class A items: Special measures are taken to protect the stored goods and the temperature, humidity are controlled within a specified range.

Storehouse class B items: Goods are stored with temperature uncontrolled.

Storehouse class C items: It is an outdoor storage with a drainage system on the ground.

For storehouses of class A and B they should be fireproof, heat resisting, waterproof and well ventilated. They should not be wet and should be provided with good drainage system and preferably with a brick laying or concrete ground. For storehouses of class C, they should not be wet and should be well drained, preferably with a brick laying or crushed stone ground, should be protected from rainfall, salt corrosion, ash and other adverse conditions with a temporary cover or tent if possible

Component surfaces should not be contacted directly with the ground or ground laying material. There should be a layer of oilcloth or wax or other similar materials between the machine surface and ground surface.

All components shall be inspected for their painting, storing, sealing and any damage or wear should be repaired during acceptance and storage periodically. The inspection interval is determined by the component function, applied protection measure and storehouse class.

Many components are provided with a drying agent or sealed in a coverage (polyethylene or insulating cover) containing drying agent. The drying condition shall be inspected during storage in an interval of every 4 weeks.

9. SPECIAL TOOLS, TACKLES AND EQUIPMENT

One set of special tools and tackles required unit for the operation, maintenance, inspection and repair of the individual main equipment and auxiliary equipment shall be supplied by the Contractors in sufficient quantity to equip the shift personnel, maintenance personnel and workshop craftsman for commissioning, testing, calibration, modification and maintenance of the unit, List of such special tools, tackles and equipment shall be submitted in the EPC bid.

Special tools and tackles excludes conventional ones and those locally available normally (not those requiring a drawing and considered as those made to order).



The special tools and equipment for maintenance and repair shall be delivered by the Contractor in lockable steel boxes and they shall be marked in an approved manner for identification purposes and a corresponding tool chart shall be supplied with the steel boxes.

The following tools and appliances shall be supplied under this Contract for use by the Owner/Owner's representative:

- Two sets of special tools and gauges required for the maintenance of the Plant
- One set of special lifting and handling tackles / appliances required for the maintenance of the Plant.

The tools, tackles and appliances supplied in general, shall not be used for erection purposes by the Contractor and shall be handed over in brand new condition. Damaged tools, tackles, and appliances shall be replaced before handing over.

The exception to this is the special lifting gear which may be used provided that when it is handed over to the Owner/Owner's representative it has not been subjected to more than normal wear and is still fully suitable for its intended use.

Each set of tools, gauges and appliances under category (a) above shall be suitably arranged in fitted boxes of mild steel construction, the number of boxes being determined in relation to the layout of the plant and equipment in question.

If the weight of any box and its contents should be such that it cannot conveniently be carried, it shall be supported on steerable rubber-tyred wheels.

Each cabinet and box shall be painted, fitted with a lock and clearly marked in white letters with the name of the item of equipment for which the tools and appliances contained are intended.

Suitable storage racks shall be provided for all portable lifting tackle supplied under this contract. Suitable lifting lugs, ears or ring bolts, or tapped holes for lifting rings shall be provided on all equipment items where the weight exceeds 15 Kg.

All lifting tackle shall be stamped with a unique identification number and safe working load. A test certificate from an approved Authority shall be supplied for each item of lifting tackle.

The Contractor shall provide a schedule of all lifting tackle and tools and appliances being supplied, for the approval of the Owner/Owner's representative.

The Contractor shall provide all runway beams, trolleys, lifting blocks, special slings necessary for the safe and efficient handling and maintenance of the works. Particular attention shall be paid to handling of equipment located at higher elevations safety valves.

The tools and appliances with the appropriate storage racks, cabinets and boxes shall be handed over to the Owner/Owner's representative at the time of Taking Over of the complete Plant.

Since the Contract includes site erection, any special tools or appliances required solely for erection shall be provided by the Contractor for his own use and shall remain the property of the Contractor.

Control and Instrumentation: Software with associated hardware required to access instruments or control systems to be provided.



10. Painting, Insulation, Anti-dewing

Anti-corrosive coatings and painting shall be carried out as a pre-treatment to all equipment and parts. The paint system used should coordinate with the painted objects and surrounding conditions of project.

In multi-layer painting system, different painting layers should be selected to make the painting coordinate. If multi-layer painting system is used, various painting layers should have distinct colours so that the later layer can be distinguished from the former one.

After the equipment or apparatus finished preliminary or full painting, it can be supplied to field. After the installation is finished, ground coat must be painted.

Entire painting procedure should be supplied in order to repair the injures of painting coat after the equipment is delivered to field.

Colour strip indication system should be used for pipes. These strips should be painted on the joint of pipes, entrance, valves of pipe. This pipe without outside protection layer should be marked by some colour in whole length.

The principal colour of field equipment should be determined by Owner/Owner's representative and Contractor during execution stage. For Electrical equipment, paint shade shall be as mentioned in the equipment Specification.

Further requirements with regard to painting, insulation, and anti-dewing are specified in the relevant sections in the detailed technical specifications. The specified requirements shall be applied to the whole equipment and facilities of the Contract.

Insulation specification for MPP supplied equipment shall be as mentioned in detailed technical specification.

Language to be used

English shall be used as the general Contract language English translations shall be provided for any code and standards not in English language.

Name plates of equipment and instrument scale shall be marked in English.

Documents for training shall be provided in English.

Danger signs / Exit signs shall be in English, Hindi and Gujarati.

11. CONSUMABLES

11.1. Lubricants and greases

All lubricants proposed for the Plant operation shall be suitable for all operating and environmental conditions that will be met on site.

All oils and greases shall where possible be readily available in India.

The number of oils and greases shall be kept to a minimum to the extent feasible. For each type and grade of lubricant recommended the contractor shall list at least three equivalent lubricants manufactured by alternative companies. This will be in line with that suggested by

OEM and outcome will be informed to the Owner/Owner's representative.



In case of imported oils, lubricants and other consumables, the contractor shall indicate the indigenous equivalents to enable the Owner/Owner's representative to arrange subsequent fills. Preference should be given to indigenous oils and lubricants during first filling itself. Short shelf life items if any may be supplied in a phased manner keeping in view of their actual use.

The Contractor shall supply the first fill lubricants and greases, and also shall provide at the

Completion Certificate sufficient lubricants and greases necessary for the efficient operation and maintenance of the Plant at full load 24 hours per day for a period as mentioned in the relevant portion of Commercial Specification.

11.2. Chemicals and other consumables

Contract includes the supply (by the Contractor) of all chemicals, reagents, resins, and other consumables required for testing, commissioning and setting to work of each section of the Works.

The Contractor shall provide all chemicals and other consumables required for the efficient operation and maintenance of the plant at full load 24 hours per day for a period as mentioned in the relevant portion of Commercial Specification.

The Contractor shall prepare a list of these consumables giving quantities necessary for each section of the works and the recommended suppliers.

The Contractor shall deliver to site sufficient quantities of consumables in his supply to allow for 6 months running of the Works prior to the issue of the Completion Certificate. The delivery of the remainder of the consumables shall be programmed to suit the operational requirements and space availability within the various stores.

12. Plant and Equipment Identification

The contractor shall follow identification system for the whole plant equipment, instruments, facilities and systems as per the Annexure-4 Guide for Coding Equipment, Documents & Drawings MPP generated drawings, identification system shall be based on MPP standard.

Labelling

Name plates which are to be firmly fixed on all the equipment, instruments, buildings and structures shall be provided. For equipment of small size, these are to be fixed on the piping or structure adjacent to the equipment. The contents of nameplate are to include the designation and principal parameters of the equipment.

The nameplate within the field shall be made of a high temperature - resistant metallic sheets, with designation permanently engraved on them. Indoor installed equipment (e.g., panels, cabinets, switchgear) shall also be labelled by appropriate name plate.

The form, size, base colour and colour of contents of the name plates and prompting plates will be agreed between the Contractor and the Owner/Owner's representative. It shall be possible for these to be readily seen by the operator. The designation of warning tags shall be different from that of other tags. All buried pipes and cables routes shall be identified with permanent marker.



SECTION 4
GENERAL TECHNICAL PARTICULARS

EOT DATA SHEET- A

S.N.	Description	Technical Particulars
1.0.0	GENERAL	3.5 T, Single Girder EOT Crane at 66KV GIS Building
1.1.0	Name of Manufacturer	
	a) EOT Crane	*
	b) Crane motors	*
	c) Control Equipments	*
	d) Runway conductors	*
1.2.0	WEIGHT OF EQUIPMENTS	
	a) Crane weight (Kgs.)*	*
	b) Weight of DSL (Kgs.)*	*
1.3.0	Design, fabrication and testing of crane conform to standard/ code	IS-3177 / 807/IS-3938
1.4.0	Number of cranes	01
1.5.0	Crane Classification	Class-II (M 5) as per IS-3177 / IS-807
1.6.0	Type of service	-----Indoor-----
1.7.0	Type of Crane	Single Girder Over Head EOT
1.8.0	Capacity (SWC)	3.5 Tones
1.9.0	Span	7.4 m
1.10.0	Lift	5.5 m
1.11.0	Over Load Test	(125% of rated capacity-SWC)
1.12.0	Crane structure	Single girder
1.13.0	Design ambient temp.	50 ⁰ C
1.14.0	Runway Rail	
1.14.1	Type & Size	40 mm Sq. Bar or of suitable size.
1.14.2	Material	*
1.14.3	Weight per meter	*
1.15.0	End carriage	



CLIENT: OIL & NATURAL GAS CORPORATION (ONGC)
PROJECT: 1 X 51 MW CCCPP, HAZIRA, GUJARAT - 66 KV GIS
CONSULTANT: FICHTNER CONSULTING ENGINEERS (INDIA) PVT. LTD.
TECHNICAL SPECIFICATION FOR EOT CRANE

TB-383-563-033

Rev. 0

Page | 2

1.15.1	Material	M.S. as per IS: 2062
1.15.2	Manufacturer	As per List given in schedule-1 of this document
1.16.0	Main girder	
1.16.1	Type & Size	Single Girder Overhead EOT
1.16.2	Material	M.S. as per IS: 2062 GR A/B
1.16.3	Manufacturer	As per List given in schedule-1 of this document
1.17.0	Power supply	415V \pm 10%, 3 phase, 4 wire, 50 Hz+3%, \pm 5% variation. Combined voltage and frequency variation 10% (Shall be arranged by BHEL at 1.5 meter above floor level/ operating level)
1.18.0	Control Supply	24 V/110 V (Shall be arranged by vendor)
1.19.0	Load test	As per IS: 3177
2.0.0	CRANE PERFORMANCE	
2.1.0	Operation	Electrical -- From floor by means of Pendant Push Button controller suspended from hoist
2.2.0	Crane speed with full load	
	a) Hoist (Full speed & Creep speed)	3.0 m/min. with creep speed 10% through VVFD
	b) Cross travel (CT)	10 m/min. with creep speed 10% through VVFD
	c) Longitudinal travel (LT)	20.0 m/min. with creep speed 10% through VVFD
2.3.0	Hoisting Mechanism	Gear
2.4.0	Type of power Transmission	Gear Box
2.5.0	WIRE ROPE	
2.5.1	Make	As per List given in schedule-1 of this document
2.5.2	Core / Construction	6x36 (Steel/Fiber core) as per IS-2266
2.5.3	Wire rope dia. (mm)	*
2.5.4	Wire rope fall	*
2.5.5	Material	Plough steel
2.5.6	Tensile strength	160-180 Kg /mm ²
2.5.7	Min. Breaking load	*
2.5.8	Conform to (Std. / code)	IS-2266
2.5.9	Factor of safety	5.25 (Minimum)
2.6.0	LOAD HOOK / HOOK BLOCK	
2.6.1	Make	As per List given in schedule-1 of this document



CLIENT: OIL & NATURAL GAS CORPORATION (ONGC)
PROJECT: 1 X 51 MW CCCPP, HAZIRA, GUJARAT - 66 KV GIS
CONSULTANT: FICHTNER CONSULTING ENGINEERS (INDIA) PVT. LTD.
TECHNICAL SPECIFICATION FOR EOT CRANE

TB-383-563-033

Rev. 0

Page | 3

2.6.2	Type of load hook	Plain shank, Trapezoidal section-forged as per IS: 15560, with safety latch.		
2.6.3	Material of load hook	Class II as per IS:1875		
2.6.4	Type of Bearing of hook suspension	Thrust ball bearing		
2.6.5	Make of Bearing of hook suspension	*		
2.6.6	Type and Material of Block enclosure.	M.S. Fabricated		
2.7.0	ELECTRIC HOIST			
2.7.1	Model No.	*		
2.7.2	Duty	Class II (M5) as per IS: 3938		
2.8.0	Type of DSL			
2.8.1	Long travel	PVC shrouded DSL (GI conductor) type		
2.8.2	Cross traverse	Taut wire / Festoon cable arrangement		
2.9.0	MOTORS	M.H.	C.T.	L.T.
2.9.1	Make	As per List given in schedule-1 of this document		
2.9.2	Rating (KW)	*		
2.9.3	RPM	*		
2.9.4	Qty.	1	2	2
2.9.5	Number of poles	*	*	*
2.9.6	Type	TEFC, Sq. cage induction type,S4 duty, 40%CDF		
2.9.7	Enclosure	IP-55		
2.9.8	Number of start	150 starts/Hr.		
2.9.9	Insulation	Class – F with temperature rise limited to class-B		
2.9.10	Margin	Selected motor rating should have minimum margin of 15% over maximum including continuous load demand voltage and frequency variation, temperature rise and other factor.		
2.9.11	Supply	415V \pm 10%, 3 phase, 4 wire, 50 Hz \pm 5% variation. Combined voltage and frequency variation 10%		
2.9.12	Continuous rating	1 Hr. Rating		
2.9.13	Over load protection provided	YES		
2.9.14	Ambient Design temp.	50°C		
2.10.0	LIMIT SWITCHES			



CLIENT: OIL & NATURAL GAS CORPORATION (ONGC)
PROJECT: 1 X 51 MW CCCPP, HAZIRA, GUJARAT - 66 KV GIS
CONSULTANT: FICHTNER CONSULTING ENGINEERS (INDIA) PVT. LTD.
TECHNICAL SPECIFICATION FOR EOT CRANE

TB-383-563-033

Rev. 0

Page | 4

2.10.1	Location	M.H.	C.T.	L.T
2.10.2	Qty.	*	*	*
2.10.3	Type	Gravity / Rotary gear/ Plunger	Two way lever	Two way lever
2.10.4	Method of actuation	Snap action	Shunt type	Shunt type
2.10.5	Material of contact	Silver Cadmium		
2.10.6	Make	As per List given in schedule-1 of this document		
2.10.7	Control Voltage	110V		
2.11.0	Control panel	A suitable control panel will be provided comprising of main contactor, single phase preventer with VVVF drive, transformer, fuses, MCB's, etc.		
2.12.0	BRAKES			
2.12.1	Location	M.H. Creep	C.T.	L.T.
2.12.2	Qty.	*	*	*
2.12.4	Type	DCEM / (Disc type)		
2.12.5	Capacity	200% FLT	150% FLT	150% FLT
2.12.6	Size / rating	*		
2.12.7	Make	As per List given in schedule-1 of this document		
2.13.0	GEAR (HOISTING)			
2.13.1	Make	As per List given in schedule-1 of this document		
2.13.2	Type	Spur / Helical		
2.13.3	Material	Gear: EN8 / 20 Mn Cr5 / 16 Mn Cr Pinion: EN9		
2.13.4	Lubrication	Grease / Oil splash		
2.13.5	Reduction Ratio	*		
2.13.6	Bearing Make	As per List given in schedule-1 of this document		
2.13.7	Bearing Type	Antifriction deep groove ball / roller bearing		
2.13.8	Hardness (BHN)	As per IS 3177 (Latest Edition)		
2.14.0	GEAR (L.T. & C.T.)			
2.14.1	Location	C.T.	L.T.	
2.14.2	Make	As per List given in schedule-1 of this document		
2.14.3	Type	Spur / Helical	Spur / Helical	



CLIENT: OIL & NATURAL GAS CORPORATION (ONGC)
PROJECT: 1 X 51 MW CCCPP, HAZIRA, GUJARAT - 66 KV GIS
CONSULTANT: FICHTNER CONSULTING ENGINEERS (INDIA) PVT. LTD.
TECHNICAL SPECIFICATION FOR EOT CRANE

TB-383-563-033

Rev. 0

Page | 5

2.14.4	Material	Gear: EN8 / 20 Mn Cr / 16 Mn Cr Pinion: EN9/55C8	Gear: EN8 / 20 Mn Cr / 16 Mn Cr Pinion: EN9/55C8
2.14.5	Lubrication	Grease/ Oil splash	Grease / Oil splash
2.14.6	Reduction	*	*
2.14.7	Bearing Make	As per List given in schedule-1 of this document	
2.14.8	Bearing Type	Antifriction deep groove ball / roller bearing	Antifriction deep groove ball/ roller bearing
2.14.9	Hardness (BHN)	As per IS 3177 (Latest Edition)	
2.15.0	WIRE ROPE DRUM		
2.15.1	Material	Fabricated from M.S. as per IS: 2062 and stress relieved or seamless pipe ASTM A106 / 53 GR A / B	
2.15.2	Diameter	*	
2.15.3	Length	*	
2.15.4	Type	Unflanged	
2.15.5	Type of grooves	*	
2.16.0	WHEELS		
2.16.1	Location	C.T.	L.T.
2.16.2	Diameter (mm)	*	*
2.16.3	Qty.	*	*
2.16.4	Hardness	*	*
2.16.5	Material	EN8 / EN9	EN8 / EN9
2.16.6	Bearing make		
2.16.7	Bearing Type	Antifriction deep groove ball bearing	Antifriction deep groove ball bearing
2.16.8	Flange	Single / double	Single / double
2.16.8.	Conform to IS	IS:3938	
2.16.8.	Wheel Base	*	
2.17.0	SHEEVE		
2.17.1	Material	C.I. Gr FG 200 as per IS-210 or Forged steel or cast steel/MS	
2.17.2	Groove dia/ O.D. (mm)	*	



2.17.3	Bearing make	As per List given in schedule-1 of this document	
2.17.4	Bearing Type	Antifriction deep groove ball bearing	
2.18.0	CONTROL PANEL	IP-55	
2.18.1	Qty	One	
2.18.2	Make	As per List given in schedule-1 of this document	
2.18.3	Location	*	
2.18.4	Size	*	
2.18.5	Thickness of sheet	2 mm	
2.19.0	ISOLATING SWITCH		
2.19.1	Qty.	One (1)	
2.19.2	Make	As per List given in schedule-1 of this document	
2.19.3	Rating	*	
2.20.0	PENDANT PUSH BUTTON	To be provided	
2.20.1	Cables	Power	Control
		Aluminum minimum 16mm ² stranded (PVC FRLS)	Copper, minimum 2.5 mm ² stranded (PVC FRLS)
2.20.2	Make	As per List given in schedule-1 of this document	
2.20.3	Material	MS CRCA Sheet	
2.20.4	Type	Fabricated	
2.20.5	Dearing factor to be considered	YES	YES
2.20.6	Voltage grade	1100V	
2.21.0	END STOPPER		
2.21.1	Qty.	4 Nos.	
2.21.2	Material	M.S.	
2.22.0	BUFFER		
2.22.1	Location	CT	LT
2.22.2	Qty	NA	Four
2.22.3	Material	NA	Spring
2.22.4	Make	As per List given in schedule-1 of this document	
2.23.0	PAINTING	As per spec.	



2.24.0	Control for Hoisting, CT and LT operations	Thru' VVVF drives
a.	Speed Control	Thru' VVVF with minimum 6 pulse design
b.	Starting torque of VVVF	Upto 400% typical with Encoder
c.	Starting current	Less than 150 % of rated torque
d.	Temperature	Capable of withstanding upto 45°C without derating

Note:

- The cranes shall be VVVF Drive controlled in all three motions i.e. Hoisting, CT and LT.
 - Red warning lamps to be provided at the end of gantry.
 - Hook Latch to be provided.
 - Cast Iron drum shall be flanged at both ends.
 - Nylon sheaves will not be acceptable.
 - Only antifriction bearing applicable for all cranes.
 - Plastic / Rubber / Polyurethane Buffers not acceptable.
 - The motors shall be energy efficient.
 - The cable shall be of Copper only.
 - ±5% variation shall be considered in Lift and span of the crane.
 - Deration factor shall be considered in motor sizing of the crane inline with IS: 3177.
- ✓ Technical details against the (*) marked item shall be finalized as per the requirement during detailed engineering stage for this item.

• LIST OF DOCUMENTS/ DRAWINGS

In this section Technical Datasheets (TDS) of various equipment/items and system drawings that are required to be generated is furnished herewith. List of datasheets/drawings and numbers to be accorded is also given below.

The list furnished here is tentative and additional documents may be required during detailed engineering.

S No.	Item Description	Drg/ Doc. No.
1	Data Sheet of SG EOT CRANE (GIS Building)	TB-DS-383-563-01
2	GA Drg. of SG EOT Crane	TB-DG-383-563-02
3	Sizing Calculations for SG EOT Crane	TB-CL-383-563-03
4	Electrical Drg. for SG EOT Crane	TB-DG-383-563-04
5	BOQ for SG EOT Crane	TB-BQ-383-563-05



CLIENT: OIL & NATURAL GAS CORPORATION (ONGC)
PROJECT: 1 X 51 MW CCCPP, HAZIRA, GUJARAT - 66 KV GIS
CONSULTANT: FICHTNER CONSULTING ENGINEERS (INDIA) PVT. LTD.
TECHNICAL SPECIFICATION FOR EOT CRANE

TB-383-563-033

Rev. 0

Page | 8

SECTION- 5

ENCLOSURES TO SPECIFICATION

SCHEDULES TO BE FILLED UP BY THE BIDDER

- Schedule 1 **Schedule of makes of Equipments**
- Schedule 2 **Schedules of Deviations**
- Schedule 3 **Schedule of past experience and qualifying requirements**
- Schedule 4 **Schedule of performance certificates**
- Schedule 5 **Schedule of type test and special tests**
- Schedule 6 **Details of contact persons (technical & commercial)**
- Schedule 7 **Enclosures to Specification**



SCHEDULE-1

MAKES OF IMPORTANT ITEMS / COMPONENTS OF EQUIPMENTS AND THEIR DETAILS

ITEM NAME	NAME OF MANUFACTURER	PLACE OF MANUFACTURE OF ITEM	PLACE OF TESTING AND INSPECTION	COMPLIANCE WITH ISO 9001 (YES/NO)

Place

Signature of the authorized representative of Bidder

Name -----

Date

Designation-----

Company seal-----



SCHEDULE-2

SCHEDULE OF TECHNICAL DEVIATION

The following are the deviations / variations / exceptions from the specification:

Section	Clause No. / Page No.	Statement of deviation/ Variations/Exceptions
---------	--------------------------	--

-
- 1) In case, this schedule is not submitted, it will be presumed that the equipment /material to be supplied under this contract are deemed to be in compliance with the specification.
 - 2) If there is NIL deviation, even then the format to be filled as **NIL DEVIATION**
 - 3) Continuation sheets of like size and format may be used as per the Bidder's Requirement and shall be annexed to this schedule.

Place

Signature of the authorized representative of Bidder

Name -----

Date

Designation-----

Company seal-----



SCHEDULE – 3

SCHEDULE OF PAST EXPERIENCE AND QUALIFYING REQUIREMENT

Following is the list of earlier orders executed by us for supply of equipment / material of similar nature over the last past five years:

S.No.	Item	Brief rating	Qty	customer	Date	Date Of order	Date of supply	Order value
-------	------	--------------	-----	----------	------	------------------	-------------------	----------------

Place

Signature of the authorized representative of Bidder

Date

Name-----

Designation-----

Company seal -----

Note: Continuation sheets of like size and format may be used as per the Bidder's Requirement and shall be annexed to this schedule.



SCHEDULE – 4

SCHEDULE OF PERFORMANCE CERTIFICATE

Bidder shall furnish the performance certificate of the similar equipment having
The following details:

S.No.	Item	Brief rating	Qty	Customer	Date Of supply
-------	------	--------------	-----	----------	-------------------

Place

Signature of the authorized representative of Bidder

Date

Name-----

Designation-----

Company seal -----

Note:

Continuation sheets of like size and format may be used as per the Bidder's Requirement and shall be annexed to this schedule.



SCHEDULE-5

SCHEDULE OF TYPE TESTS AND SPECIAL TESTS

The following type tests and special tests as called for in the Specification shall be conducted (all type tests / special tests as mentioned in the relevant clauses of the Specification shall be listed here):

Sl no	Clause no/ page no of Specification	Details of test	Lab in which to be conducted	Whether test to be conducted free or on chargeable basis. Mention 'FREE' or 'CHARGEABLE'	If charges per test have been quoted for in the price bid. YES / NO
		A. Type Tests			
		1.			
		2.			
		B. Routine Tests			DO NOT
		1.			MENTION
		2.			ANY PRICE
		C. Site Tests			IN THIS
		1.			COLUMN
		2.			
		D. Special Tests (specified)			
		1.			
		2.			
		E. Other tests at works / site recommended by the Bidder			
		1.			
		2.			

NOTE:

- 1) Details have to be furnished on cables as well as accessories, each separately.
- 2) **NO PRICE SHALL BE FURNISHED IN THIS FORMAT.**

Place

Signature of the authorized representative of Bidder

Name-----

Date

Designation-----

Company seal-----



SCHEDULE-6

DETAILS OF CONTACT PERSON BOTH TECHNICAL AND COMMERCIAL

Name

Address for correspondence

Phone No.

Fax No.

Email

Place

Signature of the authorized representative of Bidder

Date

Name-----

Designation-----

Company seal -----

Note:

Continuation sheets of like size and format may be used as per the Bidder's Requirement and shall be annexed to this schedule.



CLIENT: OIL & NATURAL GAS CORPORATION (ONGC)
PROJECT: 1 X 51 MW CCCPP, HAZIRA, GUJARAT - 66 KV GIS
CONSULTANT: FICHTNER CONSULTING ENGINEERS (INDIA) PVT. LTD.
TECHNICAL SPECIFICATION FOR EOT CRANE

TB-383-563-033

Rev. 0

Page | 15

SCHEDULE -7

ENCLOSURES TO SPECIFICATION

DRAWINGS

1. SECTION/ELEVATION FOR 66KV GIS SUBSTATION
DRG. NO. TB-1-383-607-660-3 REV.00 (2 SHEETS)
2. GROUND FLOOR/ FIRST FLOOR PLAN OF 66KV GIS BUILDING
DRG. NO. TB-1-383-607-660-1 REV.01 (2 SHEETS)
3. MANUFACTURING QUALITY PLAN

DRG. NO. TB-1-383-607-660-1

COPY RIGHT AND CONFIDENTIAL
The information on this document is the property of BHARAT HEAVY ELECTRICALS LIMITED
it must not be used directly or indirectly in anyway detrimental to the interest of the company.

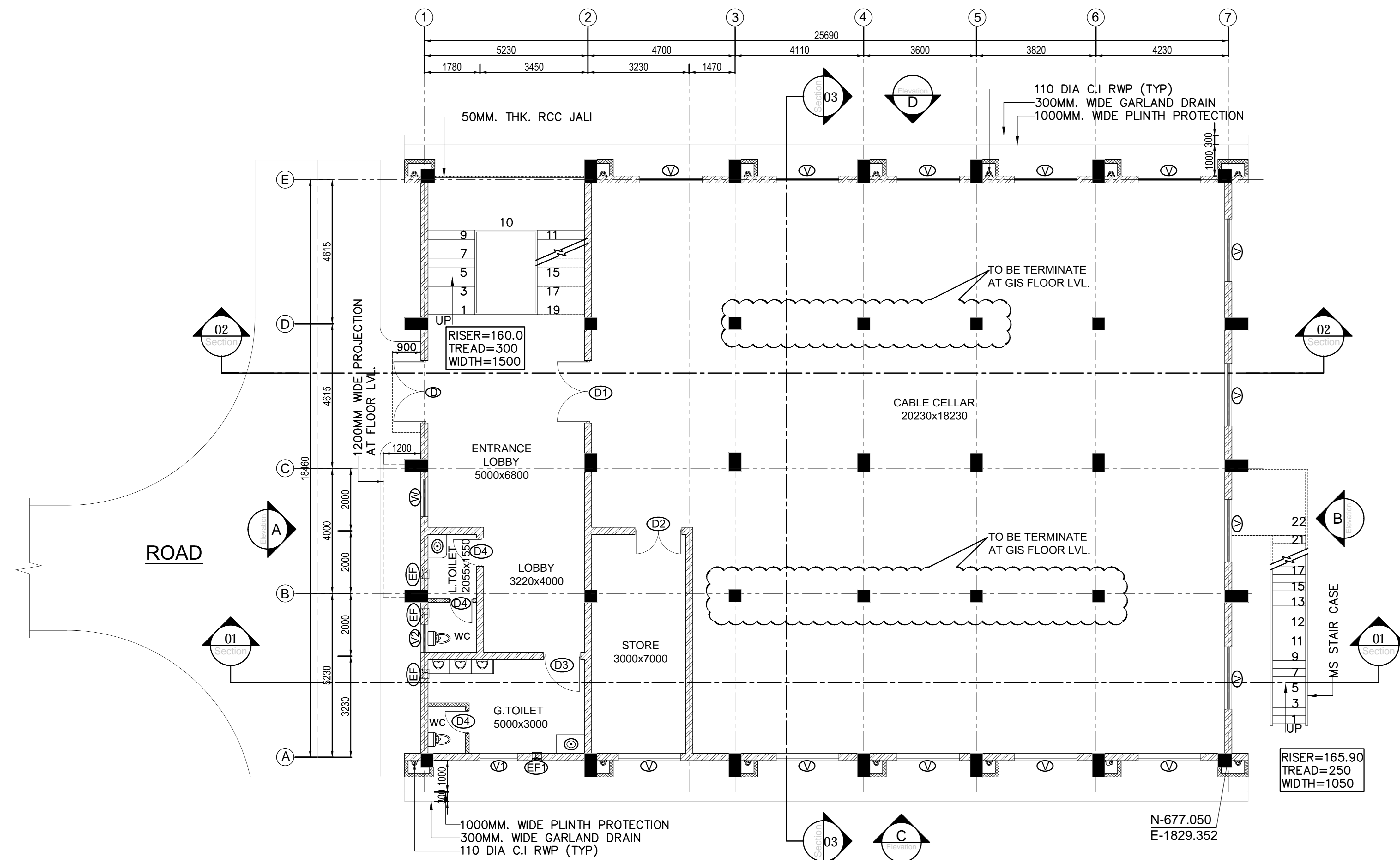

GROUND FLOOR PLAN AT RL (+) 0.500M. FFL
SCALE: 1:100

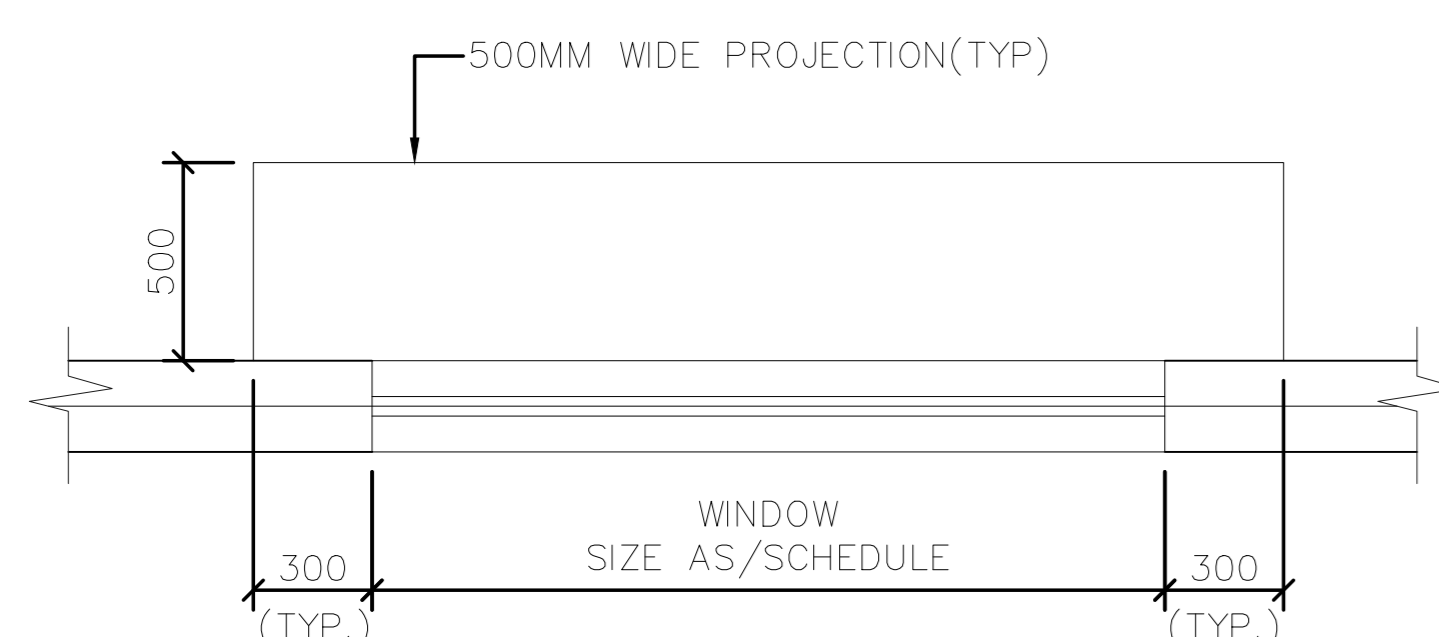

TYP. PROJECTION DETAIL
SCALE 1:25

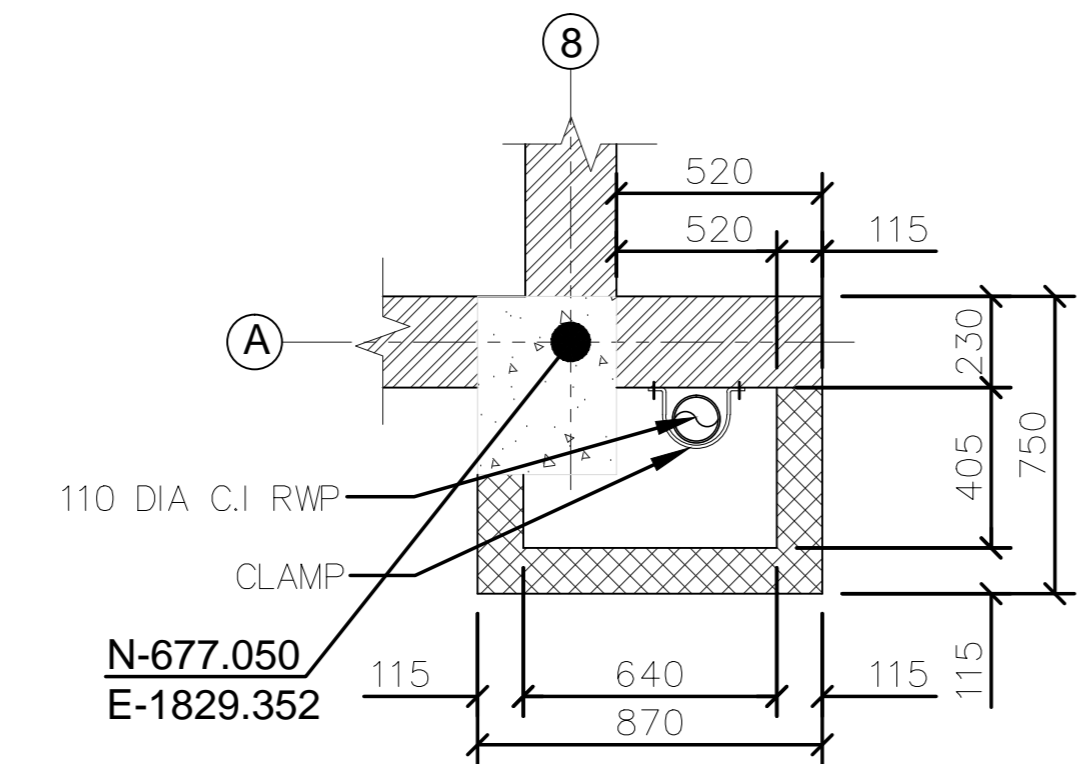

CORNER CO-ORDINATE DETAIL
SCALE 1:25

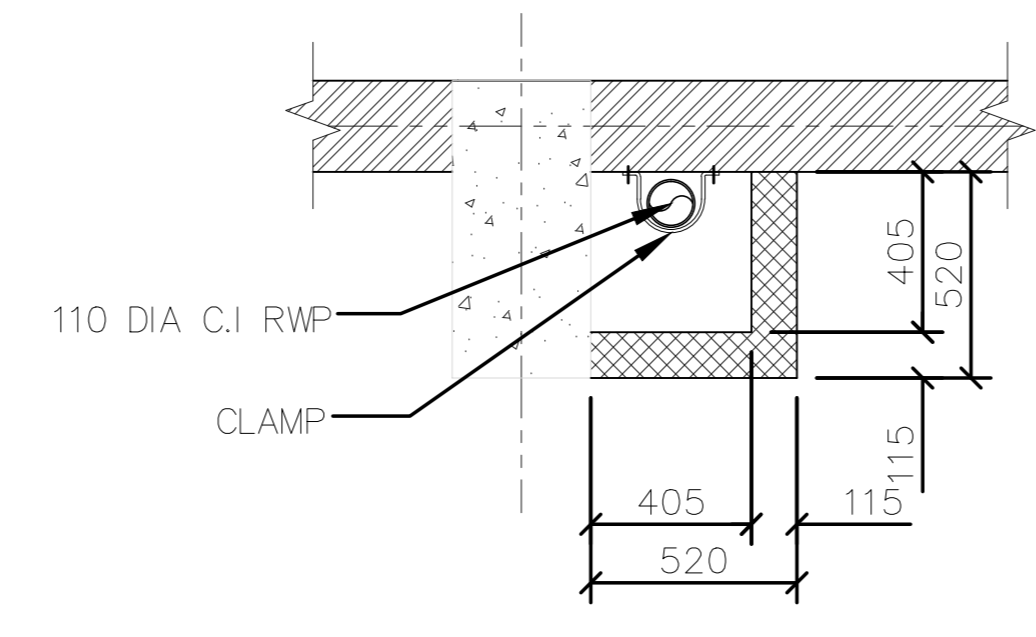

TYP. RAIN WATER FIXING DETAIL
SCALE 1:25

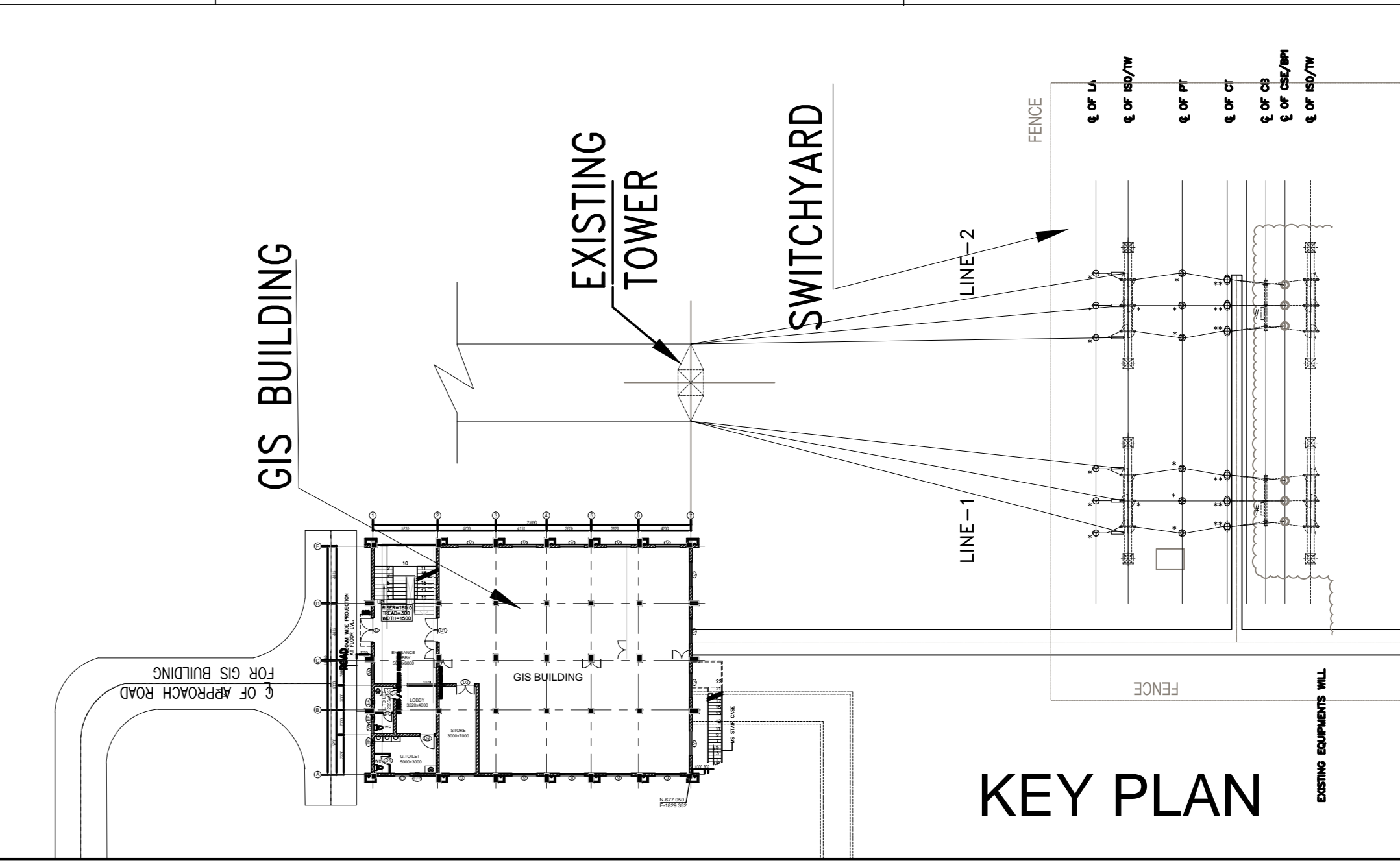

KEY PLAN

- GENERAL NOTES :-**
- ONLY WRITTEN DIMENSION SHALL BE FOLLOWED DO NOT SCALE THE DRAWING.
 - ALL DIMENSIONS ARE IN MM & LEVELS ARE IN MTR UNLESS OTHERWISE NOTED.
 - ALL MEASUREMENT MUST BE CHECKED AND VERIFIED AT SITE. ANY DISCREPANCY FOUND, TO BE NOTIFIED TO THE DESIGNER BEFORE EXECUTION.
 - FGL OF THE SITE HAS BEEN CONSIDERED AS FGL ± 0.00
 - THIS DRAWING SHALL BE READ IN CONJUNCTION WITH CONTRACT TERMS & CONDITIONS, SPECIFICATION, SCHEDULE OF ITEM & OTHER ARCHITECTURAL DRAWING.
 - FOR LOCATION OF FLOOR OPENINGS STRICTLY REFER RELEVANT STRUCTURAL DRAWING.
 - DOOR & WINDOW WIDTH MENTIONED IN THE SCHEDULE ARE CLEAR MASONRY OPENING IN WALL.
 - THE DOOR HEIGHT MENTIONED IN THE SHALL BE FROM THE FFL.
 - ALL THE DIMENSIONS OF THE ROOM ARE WALL TO WALL CLEAR DIMENSIONS.
 - DOORS & WINDOWS HAVE BEEN CHECKED FROM SPECIFICATION, FOR OTHER DETAILS ETC REF. MISCELLANEOUS DRG.

SCHEDULE OF DOOR / WINDOW OPENING (GROUND FLOOR EL 0.500M FFL)

S.NO.	TYPE.	SIZE	SILL LVL.	LINTEL LVL.	NOS.	REMARK
1.	D	2000x2400	-	2400	01	Aluminum Double Leaf Door Fully Glazed as/Spec
2.	D1	2000x2400	-	2400	01	Double Leaf Fire Proof Door Min. 2hrs Fire Rating as/Spec
3.	D3	1200x2400	-	2400	02	Single Leaf Wooden Flush Door Shutters as/Spec
4.	D4	750x2100	-	2100	03	Single Leaf Wooden Flush Door Shutters as/Spec
5.	W	1200x1400	-	2400	01	Aluminum Glazed Fix Window as/Spec
6.	V	2000x600	1800	2400	14	Aluminum Glazed Fix Ventilators as/Spec
7.	V1	1200x600	1800	2400	01	Aluminum Glazed Fix Ventilators as/Spec
8.	V2	900x600	1800	2400	01	Aluminum Glazed Fix Ventilators as/Spec
9.	V3	900x600	1800	2400	01	Aluminum Glazed Fix Ventilators as/Spec
10.	EF	300x300	2100	2400	03	Wall Opening

- REFERENCE DRG.:**
- TB-1-383-607-661-1 (Toilet Details For 66kV GIS Building)
 - TB-1-383-607-661-1 (Details of Door & Window For 66kV GIS Building)
 - TB-1-383-607-660-3 (Details of Door & Window For 66kV GIS Building)
 - TB-1-383-607-660-3 (Floor Detail & Finishing Schedule For 66kV GIS Building)
 - TB-1-383-607-660-3 (Section For 66kV GIS Building)
 - TB-1-383-607-660-3 (Elevation For 66kV GIS Building)
 - TB-1-383-607-660-2 (Terrace Plan For 66kV GIS Building)
 - TB-1-383-607-660-2 (Gantry Girder Level Plan For 66kV GIS Building)
 - TB-1-383-607-660-1 (First Floor Plan For 66kV GIS Building)
 - TB-1-383-607-660-1 (Ground Floor Plan For 66kV GIS Building)
- REF: PLOT PLAN : 0 - 381 - 01 - 01570

LEGEND :-

EL	ELEVATION
RL	REDUCED LEVEL
FGL	FINISHED GROUND LEVEL
TRL	TOP OF ROAD
FFL	FINISHED FLOOR LEVEL
BOB	BOTTOM OF BEAM
TOC	TOP OF CONCRETE
TOP	TOP OF PARAPET WALL
PCC	PLAIN CEMENT CONCRETE
TRL	TOP OF ROAD
AC+FC	AIR COND. AND FALSE CEILING
UDI	UNDER DECK INSULATION
BFC	BOTTOM OF FALSE CEILING
DPC	DAMP PROOF COURSE
WPC	WATER PROOF COURSE
D	DOOR
W	WINDOW
EF	EXHAUST FAN
WB	WASH BASIN
CI	CAST IRON
RWP	RAIN WATER PIPE
BOCR	BOTTOM OF CRANE

NAME OF PROJECT/CUSTOMER: OIL AND NATURAL GAS CORPORATION LTD.
COMBINED CYCLE CAPTIVE POWER PLANT AT HAZIRA UNIT, GUJARAT

NAME OF CONSULTANT: FITCHNER CONSULTING ENGINEERS INDIA PVT LTD

BHARAT HEAVY ELECTRICALS LIMITED
TRANSMISSION BUSINESS GROUP

DEVELOPMENT CONSULTANTS PVT. LTD.
CONSULTING ENGINEERS
KOLKATA *MUMBAI CHENNAI NEW DELHI

TITLE: **GROUND FLOOR PLAN FOR 66kV GIS BUILDING**

SCALE: 1:100 W.O. No 80003 DRG. No. TB-1-383-607-660-1

COMPUTER DRG. PATH NAME :

SIGN & DATE

INVENTORY NO.

REV.	DATE	ALTD.	CHD.	APPD.	REV.	DATE	ALTD.	CHD.	APPD.	NAME	SIGN.	DATE
										DRAWN	SP	16.06.16
										CHECKED	SK	
										APPROVED	AM	
DISTRIBUTION OF PRINTS										DEPT.	CODE	
										TBEM	422	

CARD CODE	
NEXT SHEET	
SHEET No.	1
REV.	0

GENERAL NOTES :-

- FOR GENERAL NOTES REFER DWG.NO. TB-1-383-607-660-1

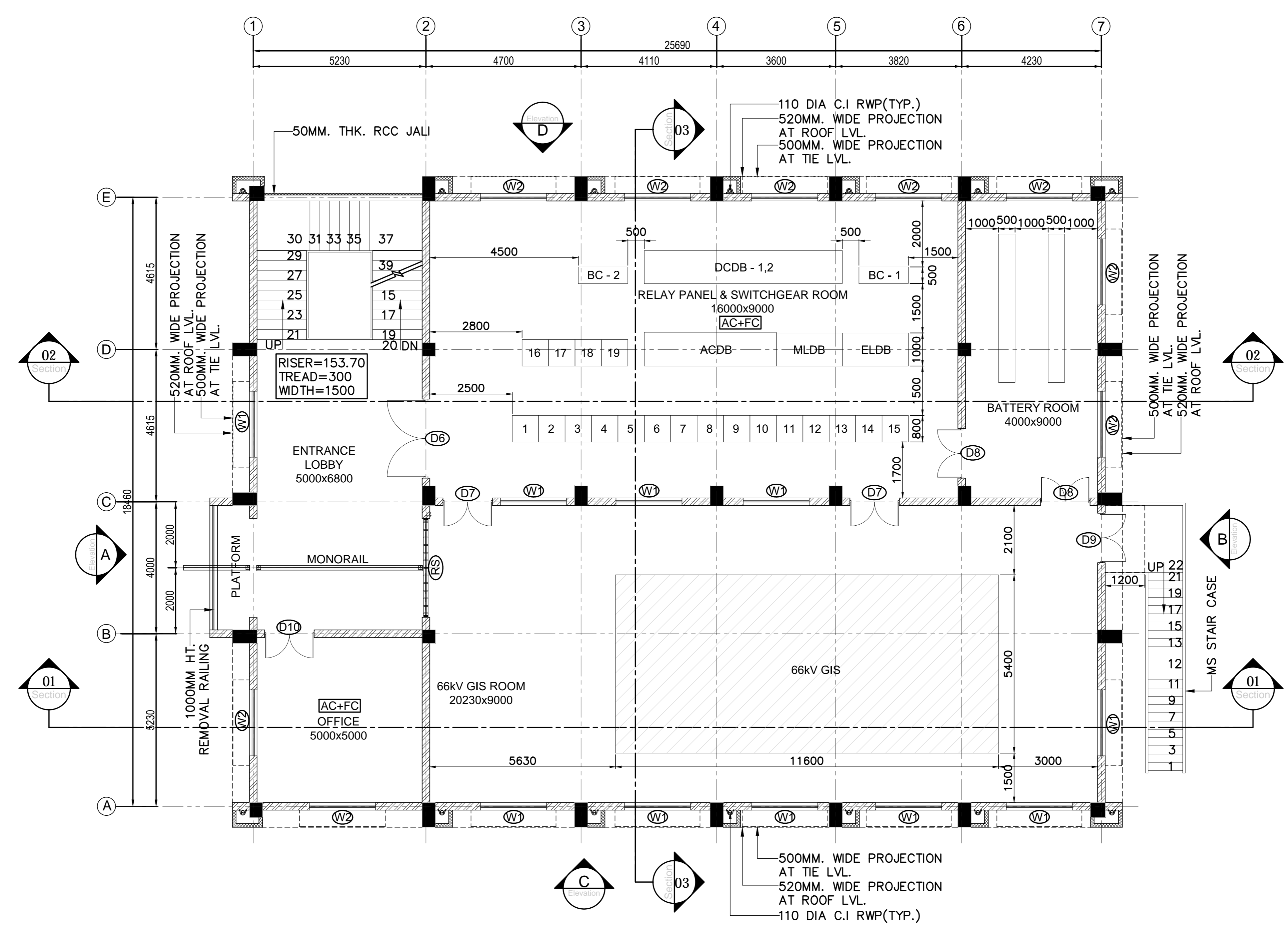

FIRST FLOOR PLAN AT RL (+) 3.750M. TOC
SCALE: 1:100

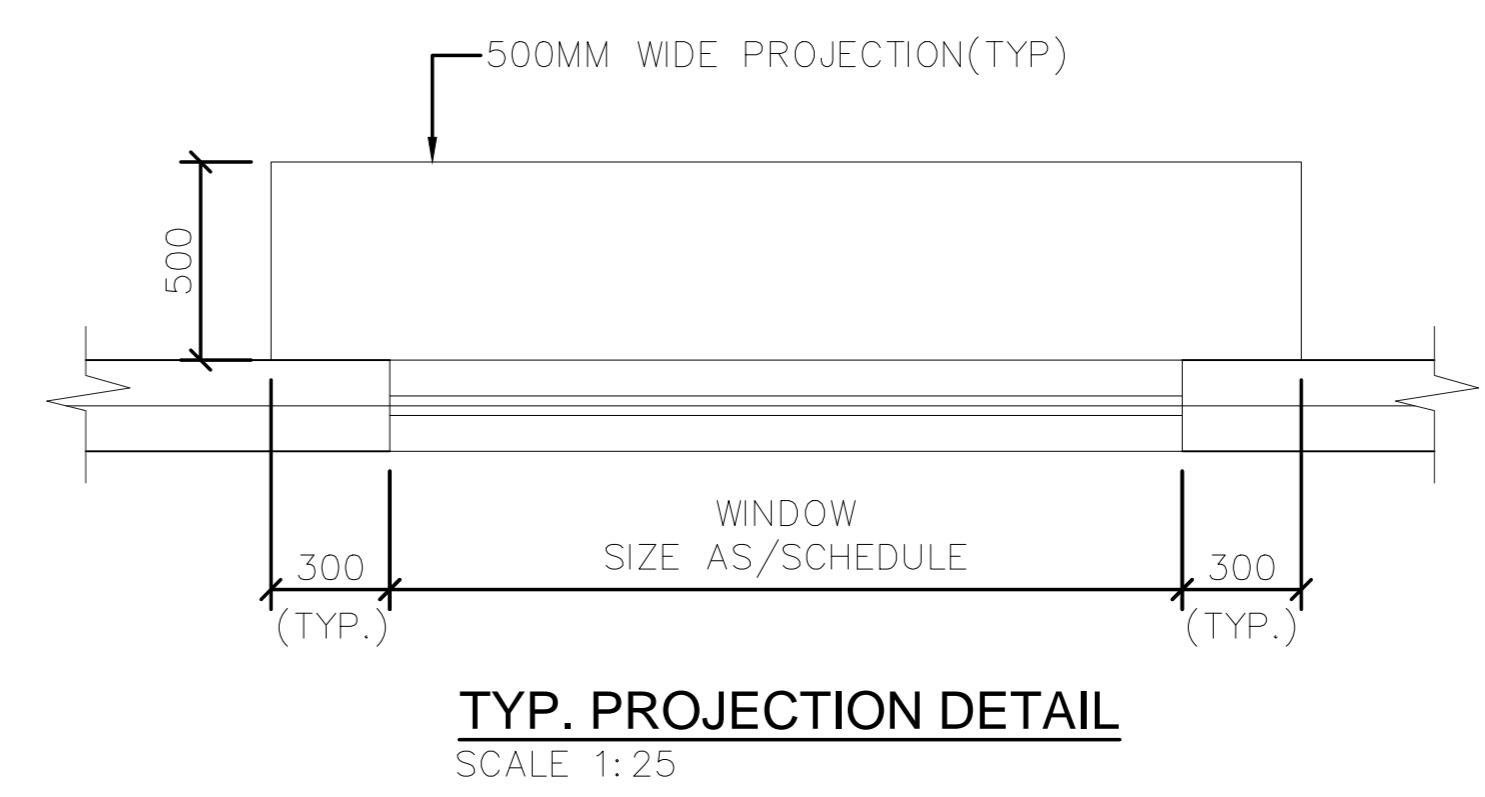

LEGEND :-

EL	ELEVATION
RL	REDUCED LEVEL
FGL	FINISHED GROUND LEVEL
TRL	TOP OF ROAD
FFL	FINISHED FLOOR LEVEL
BOB	BOTTOM OF BEAM
TOC	TOP OF CONCRETE
TOP	TOP OF PARAPET WALL
PCC	PLAIN CEMENT CONCRETE
TRL	TOP OF ROAD
AC+FC	AIR COND. AND FALSE CEILING
UDI	UNDER DECK INSULATION
BFC	BOTTOM OF FALSE CEILING
DPC	DAMP PROOF COURSE
WPC	WATER PROOF COURSE
D	DOOR
W	WINDOW
EF	EXHAUST FAN
WB	WASH BASIN
CI	CAST IRON
RWP	RAIN WATER PIPE
BOCR	BOTTOM OF CRANE

SCHEDULE OF DOOR / WINDOW OPNING (FIRST FLOOR EL 3.700M FFL)

S.NO.	TYPE.	SIZE	SILL LVL.	LINTEL LVL.	NOS.	REMARK
1.	RS	3000x4500	-	4500	01	MS Rolling Shutter as/Spec
2.	D5	2400x2400	-	2400	01	Aluminum Double Leaf Door Fully Glazed as/Spec
3.	D6	2400x3000	-	3000	01	Aluminum Double Leaf Door Fully Glazed as/Spec
4.	D7	1500x2400	-	2400	02	Aluminum Double Leaf Door Fully Glazed as/Spec
5.	D8	1500x2400	-	2400	02	Double Leaf Fire Proof Door Min. 2hrs Fire Rating as/Spec
6.	D9	1500x2400	-	2400	01	Aluminum Double Leaf Door Fully Glazed as/Spec
7.	D10	1500x2400	-	2400	01	Double Leaf Wooden Flush Door Shutters as/Spec
8.	W1	2000x1400	-	2400	10	Aluminum Glazed Fix And Shutter Window as/Spec
9.	W2	2000x1400	-	2400	09	Aluminum Glazed Fix Window as/Spec

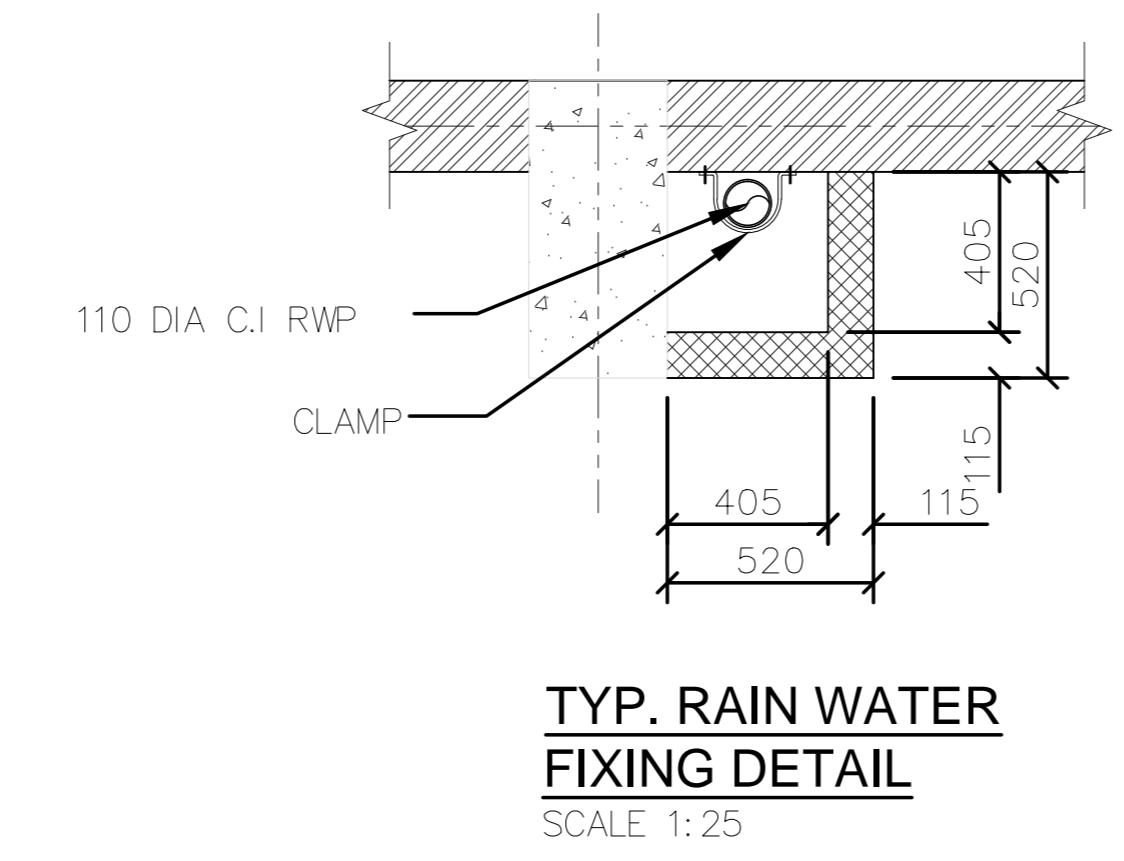
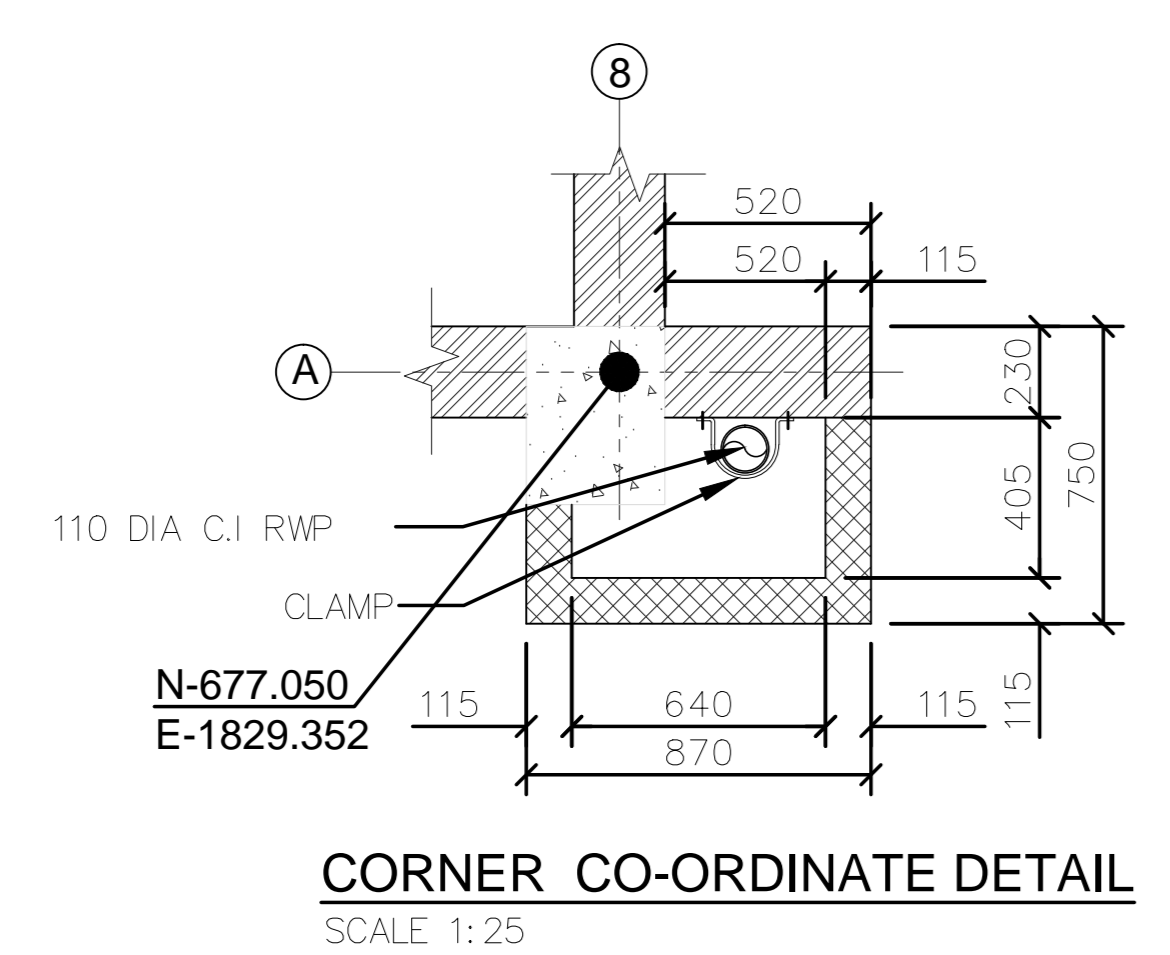

COPY RIGHT AND CONFIDENTIAL
The information on this document is the property of BHARAT HEAVY ELECTRICALS LIMITED
it must not be used directly or indirectly in anyway detrimental to the interest of the company.

COMPUTER DRG. PATH NAME :

SIGN & DATE

INVENTORY NO.

REV.	DATE	ALTD.	CHD.	APPD.	REV.	DATE	ALTD.	CHD.	APPD.	NAME	SIGN.	DATE
										DRAWN	SP	16.06.16
										CHECKED	SK	
										APPROVED	AM	
DISTRIBUTION OF PRINTS												
										DEPT.	CODE	
										TBEM	422	

NAME OF PROJECT/CUSTOMER OIL AND NATURAL GAS CORPORATION LTD.
COMBINED CYCLE CAPTIVE POWER PLANT AT HAZIRA UNIT, GUJARAT

NAME OF CONSULTANT FITCHNER CONSULTING ENGINEERS INDIA PVT LTD

BHARAT HEAVY ELECTRICALS LIMITED
TRANSMISSION BUSINESS GROUP

DEVELOPMENT CONSULTANTS PVT. LTD.
CONSULTING ENGINEERS
KOLKATA *MUMBAI CHENNAI NEW DELHI

TITLE **FIRST FLOOR PLAN FOR 66kV GIS BUILDING**

SCALE 1:100 W.O. No 80003 DRG. No. TB-1-383-607-660-1 REV. 0

CARD CODE	
NEXT SHEET	
SHEET No.	2

TB-1-383-607-660-2

DRG. NO.

1

2

3

4

5

6

7

GENERAL NOTES :-
1. FOR GENERAL NOTES REFER DWG.NO. TB-1-383-607-660-1

LEGEND :-

EL	ELEVATION
RL	REDUCED LEVEL
FGL	FINISHED GROUND LEVEL
TRL	TOP OF ROAD
FFL	FINISHED FLOOR LEVEL
BOB	BOTTOM OF BEAM
TOC	TOP OF CONCRETE
TOP	TOP OF PARAPET WALL
PCC	PLAIN CEMENT CONCRETE
TRL	TOP OF ROAD
AC+FC	AIR COND. AND FALSE CEILING
UDI	UNDER DECK INSULATION
BFC	BOTTOM OF FALSE CEILING
DPC	DAMP PROOF COURSE
WPC	WATER PROOF COURSE
D	DOOR
W	WINDOW
EF	EXHAUST FAN
WB	WASH BASIN
CI	CAST IRON
RWP	RAIN WATER PIPE
BOCR	BOTTOM OF CRANE

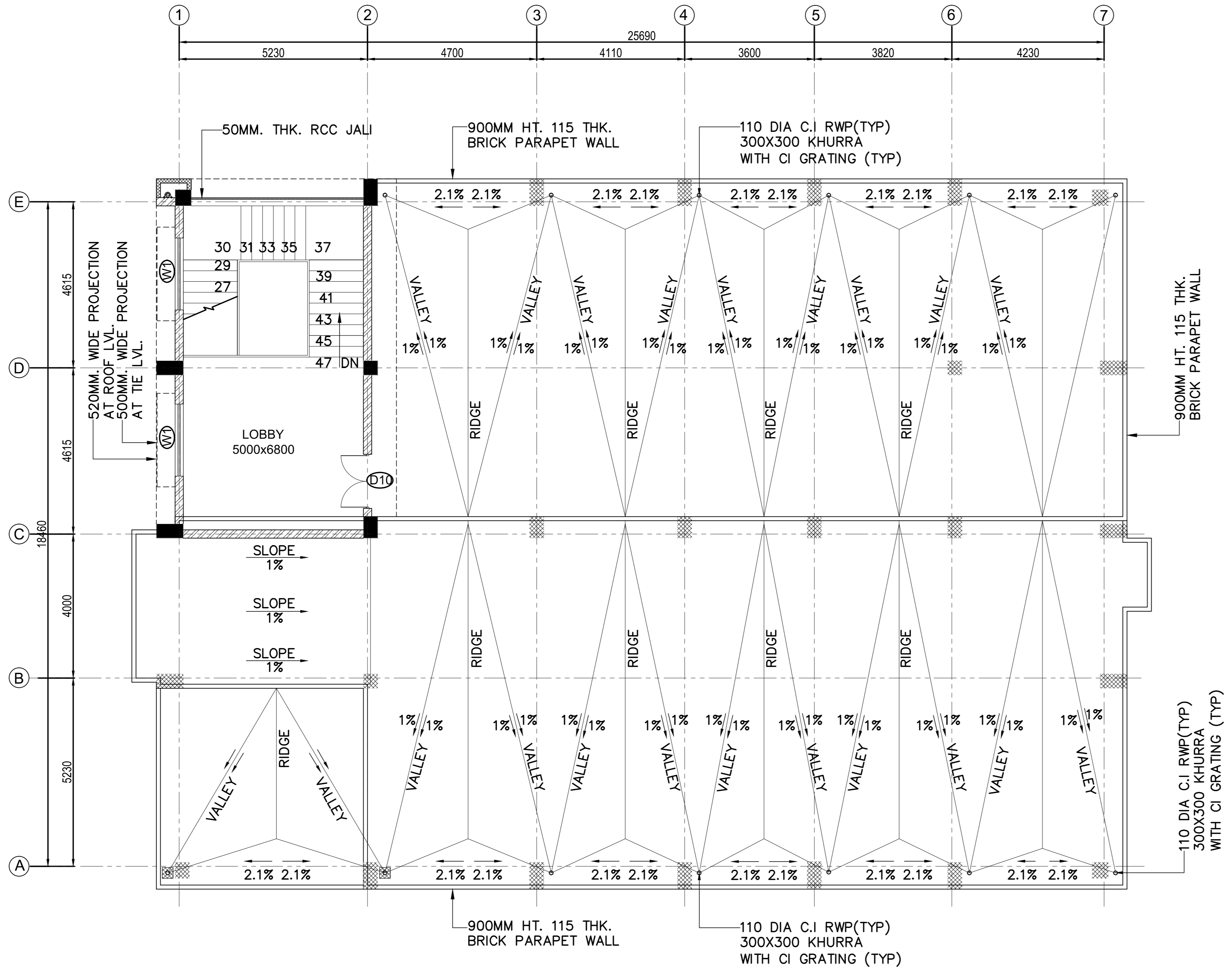

ROOF PLAN AT EL (+) 7.900M, 12.400M TOC
SCALE: 1:100
SWITCHGEAR, OFFICE ROOF EL (+) 7.900M TOC
GIS ROOM ROOF EL (+) 12.400M TOC

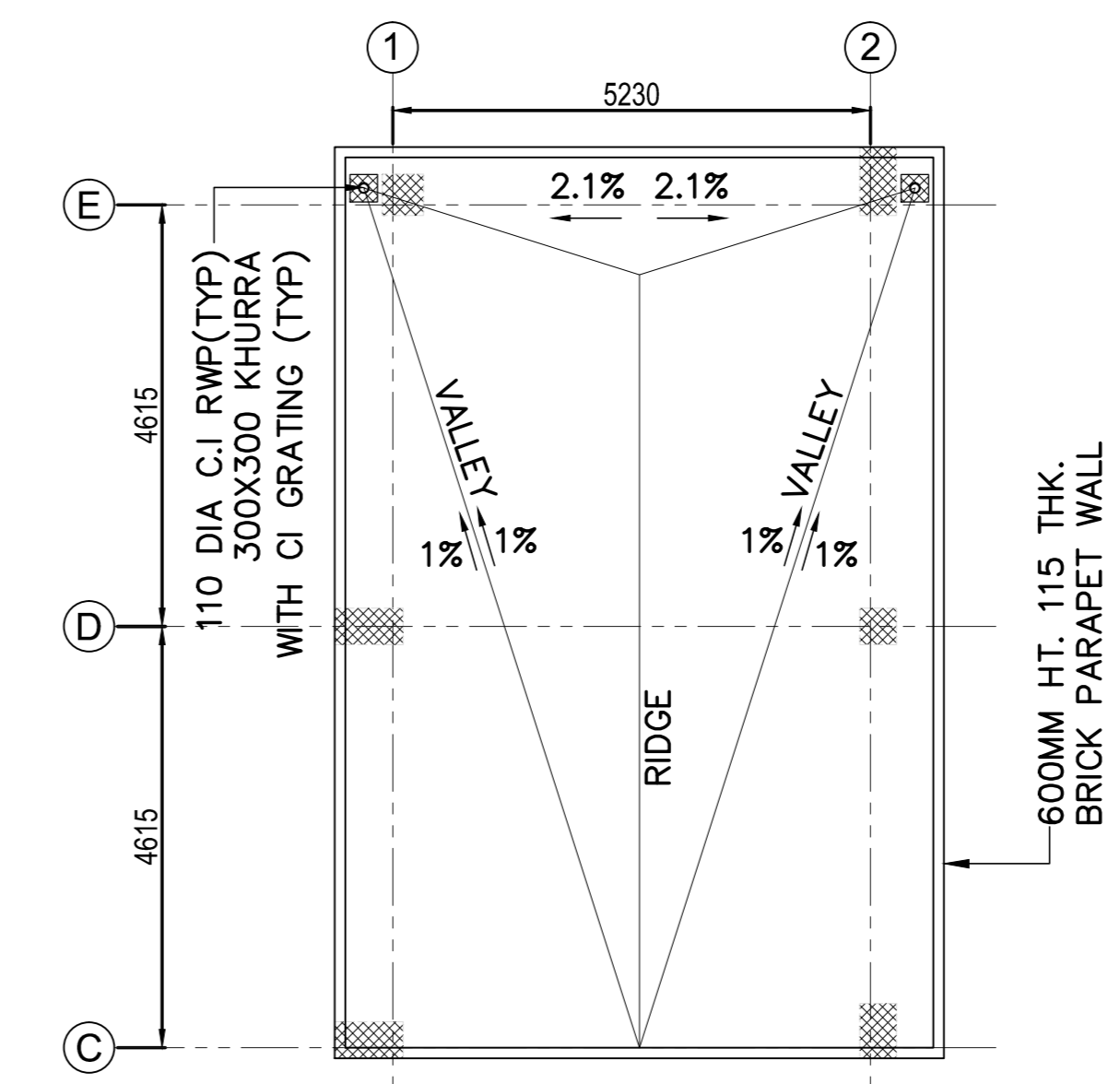

MUMTY ROOF PLAN AT EL (+) 10.950M TOC
SCALE: 1:100

REFERENCE DRG.

TB-1-383-607-661-1	(Toilet Details For 66kV GIS Building)
TB-1-383-607-661-1	(Details of Door & Window For 66kV GIS Building)
TB-1-383-607-660-3	(Details of Door & Window For 66kV GIS Building)
TB-1-383-607-660-3	(Floor Detail & Finishing Schedule For 66kV GIS Building)
TB-1-383-607-660-3	(Section For 66kV GIS Building)
TB-1-383-607-660-3	(Elevation For 66kV GIS Building)
TB-1-383-607-660-2	(Terrace Plan For 66kV GIS Building)
TB-1-383-607-660-2	(Gantry Girder Level Plan For 66kV GIS Building)
TB-1-383-607-660-1	(First Floor Plan For 66kV GIS Building)
TB-1-383-607-660-1	(Ground Floor Plan For 66kV GIS Building)

REF: PLOT PLAN : 0 - 381 - 01 - 01570

COPY RIGHT AND CONFIDENTIAL
The information on this document is the property of BHARAT HEAVY ELECTRICALS LIMITED
it must not be used directly or indirectly in anyway detrimental to the interest of the company.

COMPUTER DRG. PATH NAME :

SIGN & DATE

INVENTORY NO.

REV.	DATE	ALTD.	CHD.	APPD.	REV.	DATE	ALTD.	CHD.	APPD.	NAME	SIGN.	DATE
										DRAWN	SP	16.06.16
										CHECKED	SK	
										APPROVED	AM	
DISTRIBUTION OF PRINTS												
										DEPT.	CODE	
										TBEM	422	

NAME OF PROJECT/CUSTOMER: OIL AND NATURAL GAS CORPORATION LTD.
COMBINED CYCLE CAPTIVE POWER PLANT AT HAZIRA UNIT, GUJARAT

NAME OF CONSULTANT: FITCHNER CONSULTING ENGINEERS INDIA PVT LTD

BHARAT HEAVY ELECTRICALS LIMITED
TRANSMISSION BUSINESS GROUP

DEVELOPMENT CONSULTANTS PVT. LTD.
CONSULTING ENGINEERS
KOLKATA *MUMBAI CHENNAI NEW DELHI

TITLE: **TERRACE PLAN FOR 66kV GIS BUILDING**

SCALE: W.O. No 80003 1:100

DRG. No. TB-1-383-607-660-2

CARD CODE: NEXT SHEET SHEET No. 1

REV. 0

DRG. NO. TB-1-383-607-660-3

GENERAL NOTES :-
 1. FOR GENERAL NOTES REFER DWG.NO. TB-1-383-607-660-1

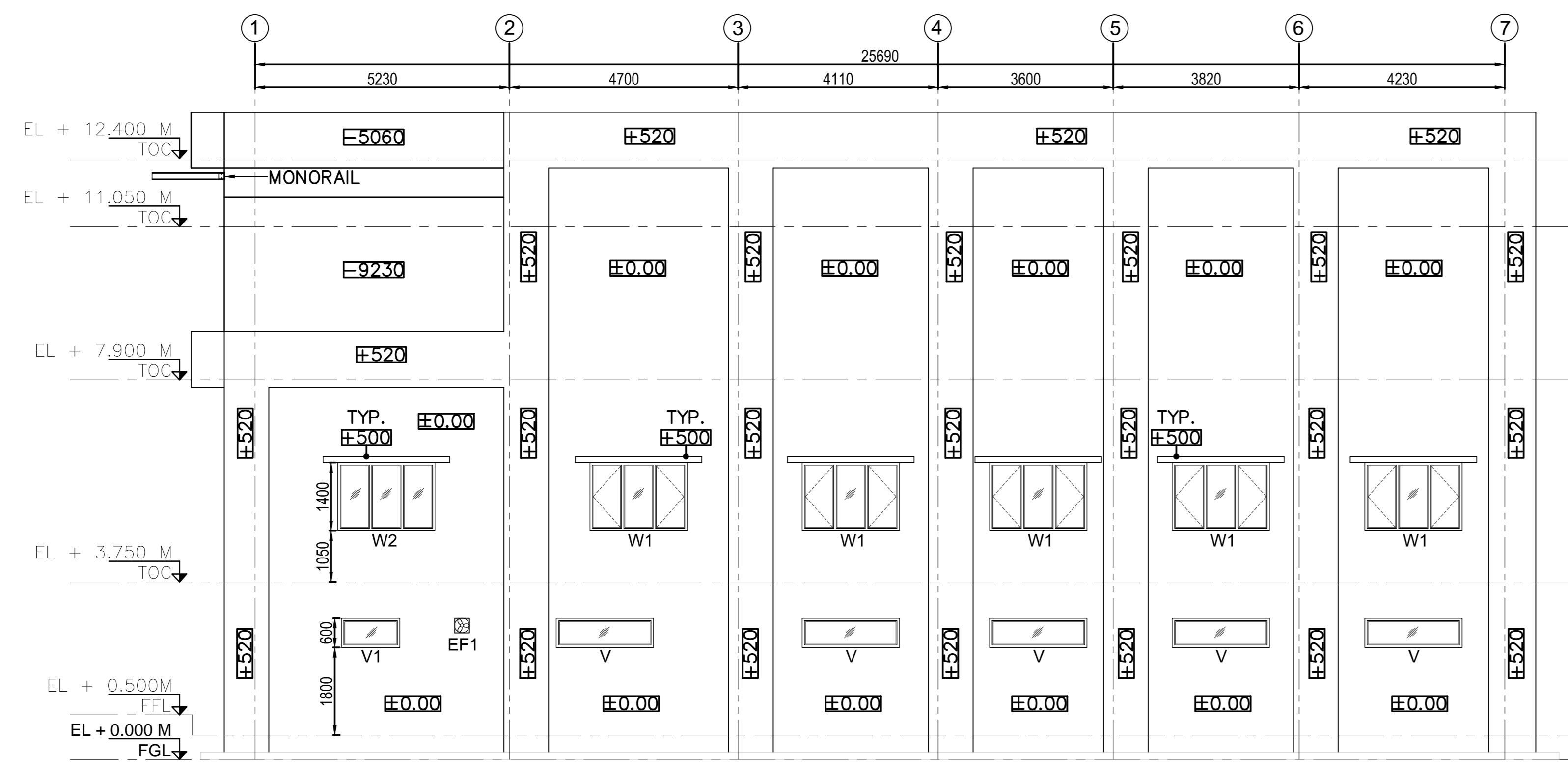

ELEVATION - C
SCALE: 1:100

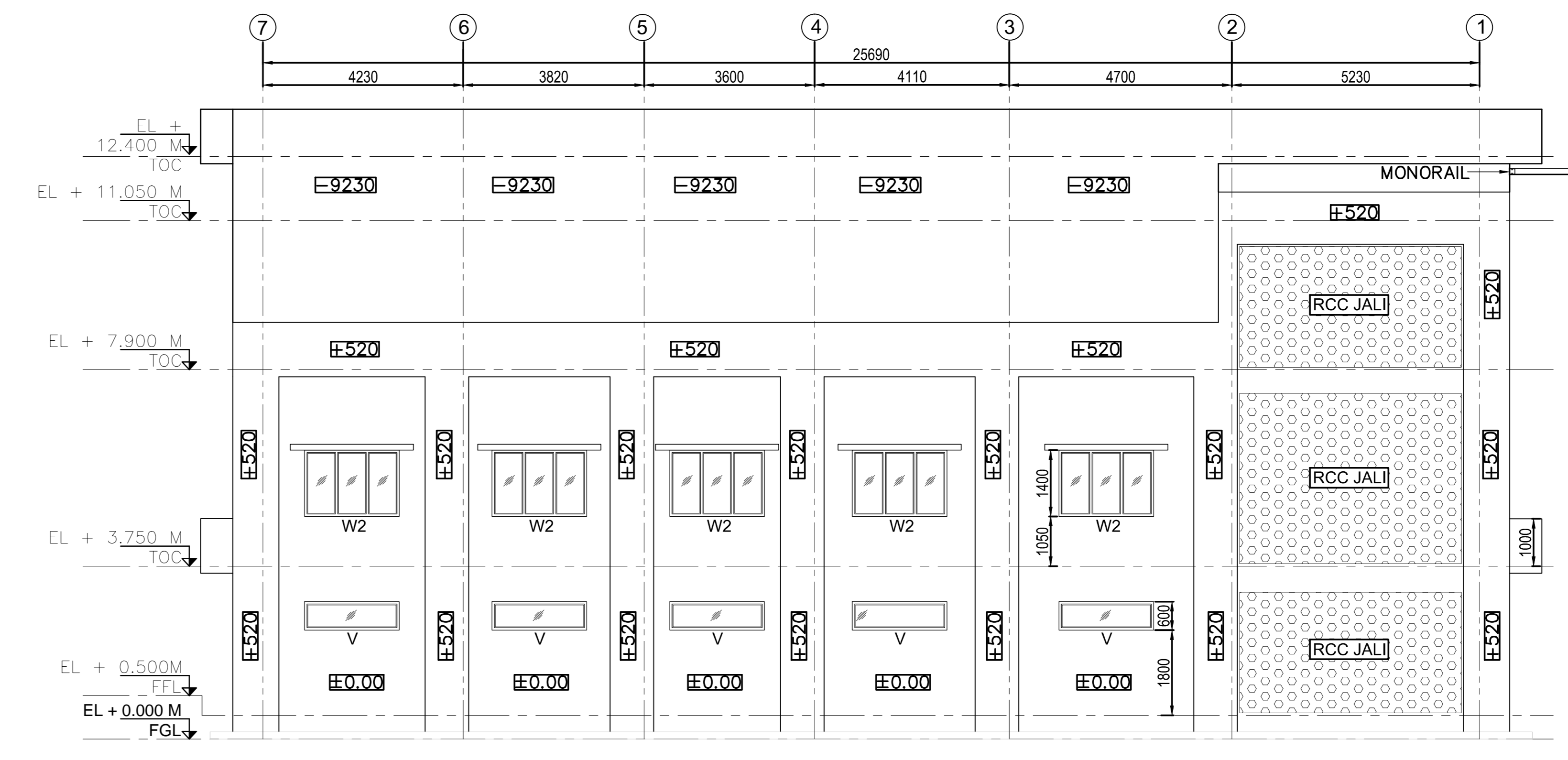

ELEVATION - D
SCALE: 1:100

LEGEND :-

EL	ELEVATION
RL	REDUCED LEVEL
FGL	FINISHED GROUND LEVEL
TRL	TOP OF ROAD
FFL	FINISHED FLOOR LEVEL
BOB	BOTTOM OF BEAM
TOC	TOP OF CONCRETE
TOP	TOP OF PARAPET WALL
PCC	PLAIN CEMENT CONCRETE
TRL	TOP OF ROAD
AC+FC	AIR COND. AND FALSE CEILING
UDI	UNDER DECK INSULATION
BFC	BOTTOM OF FALSE CEILING
DPC	DAMP PROOF COURSE
WPC	WATER PROOF COURSE
D	DOOR
W	WINDOW
EF	EXHAUST FAN
WB	WASH BASIN
CI	CAST IRON
RWP	RAIN WATER PIPE
BOCR	BOTTOM OF CRANE

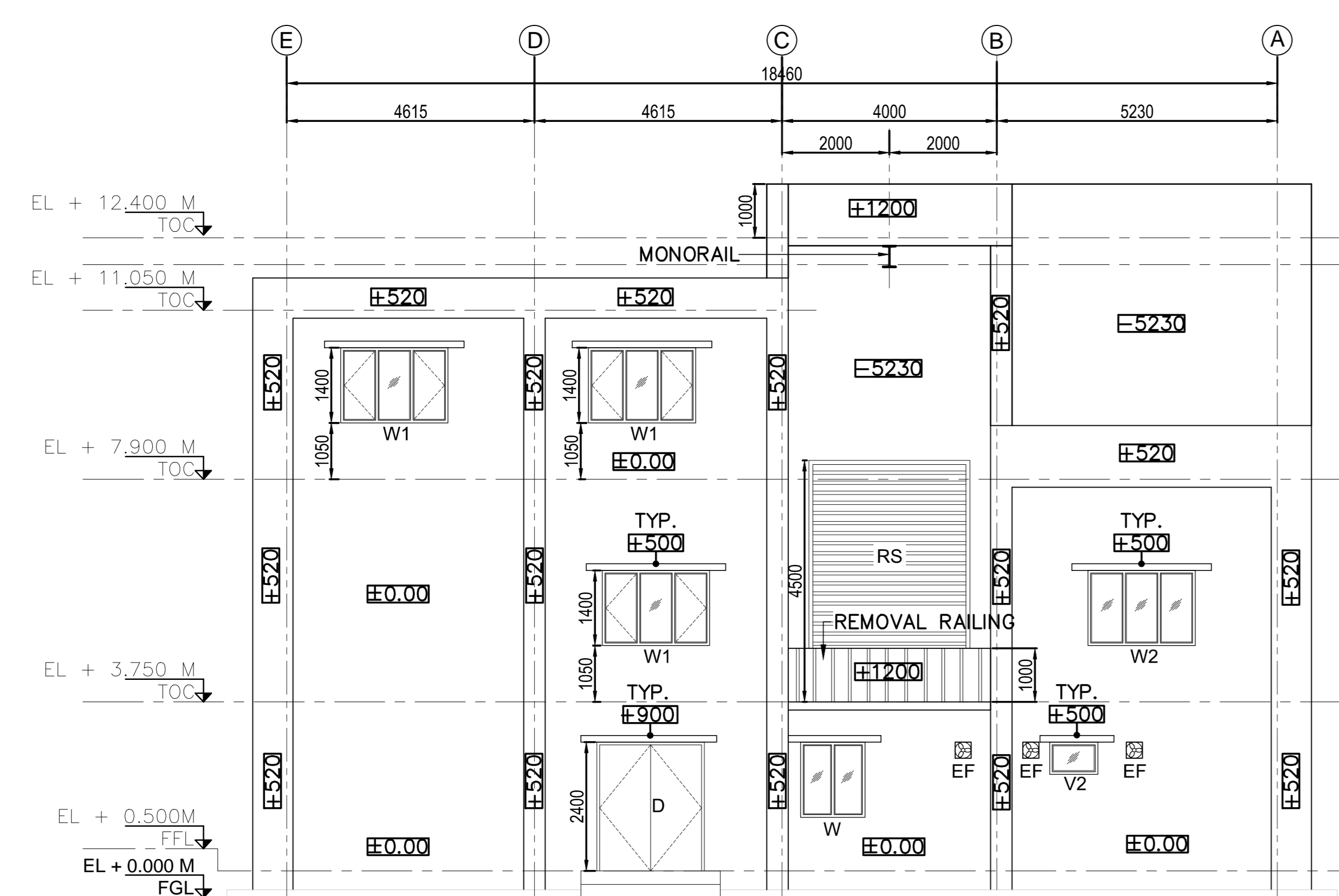

ELEVATION - A
SCALE: 1:100

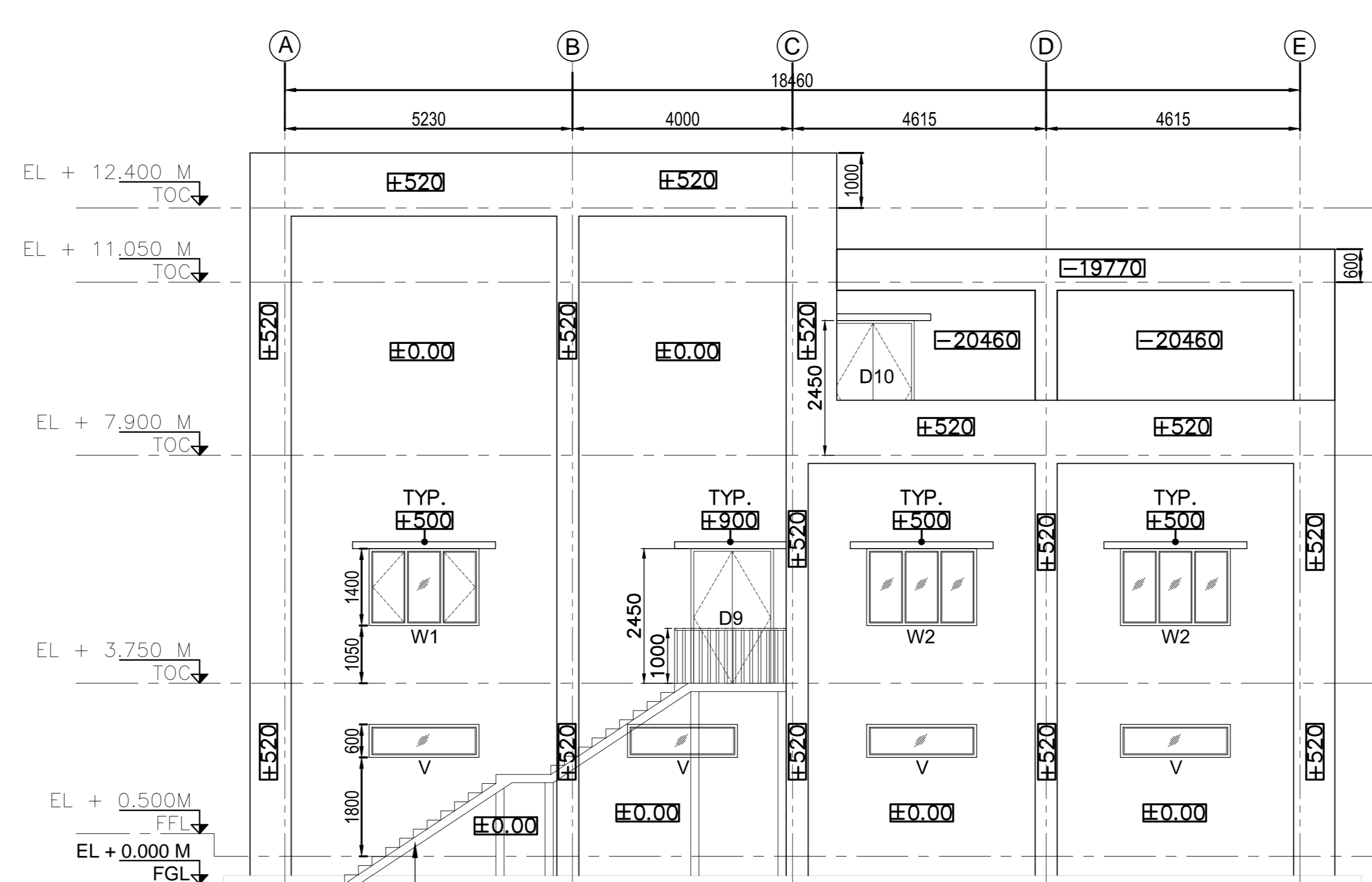

ELEVATION - B
SCALE: 1:100

REFERENCE DRG.

TB-1-383-607-661-1	(Toilet Details For 66kV GIS Building)
TB-1-383-607-661-1	(Details of Door & Window For 66kV GIS Building)
TB-1-383-607-660-3	(Details of Door & Window For 66kV GIS Building)
TB-1-383-607-660-3	(Floor Detail & Finishing Schedule For 66kV GIS Building)
TB-1-383-607-660-3	(Section For 66kV GIS Building)
TB-1-383-607-660-3	(Elevation For 66kV GIS Building)
TB-1-383-607-660-2	(Terrace Plan For 66kV GIS Building)
TB-1-383-607-660-2	(Gantry Girder Level Plan For 66kV GIS Building)
TB-1-383-607-660-1	(First Floor Plan For 66kV GIS Building)
TB-1-383-607-660-1	(Ground Floor Plan For 66kV GIS Building)

REF: PLOT PLAN : 0 - 381 - 01 - 01570

COPY RIGHT AND CONFIDENTIAL
 The information on this document is the property of BHARAT HEAVY ELECTRICALS LIMITED
 it must not be used directly or indirectly in anyway detrimental to the interest of the company.

COMPUTER DRG. PATH NAME :

SIGN & DATE

REV.	DATE	ALTD.	CHD.	APPD.	REV.	DATE	ALTD.	CHD.	APPD.	NAME	SIGN.	DATE
										DRAWN		16.06.16
										CHECKED		
										APPROVED		
DISTRIBUTION OF PRINTS												
										DEPT.	CODE	
										TBEM	422	

NAME OF PROJECT/CUSTOMER
 OIL AND NATURAL GAS CORPORATION LTD.
 COMBINED CYCLE CAPTIVE POWER PLANT AT HAZIRA UNIT, GUJARAT

NAME OF CONSULTANT
 FITCHNER CONSULTING ENGINEERS INDIA PVT LTD

 **BHARAT HEAVY ELECTRICALS LIMITED**
 TRANSMISSION BUSINESS GROUP

 DEVELOPMENT CONSULTANTS PVT. LTD.
 CONSULTING ENGINEERS
 KOLKATA *MUMBAI CHENNAI NEW DELHI

TITLE
ELEVATIONS FOR 66kV GIS BUILDING

SCALE
 W.O. No 80003 1:100

DRG. No. TB-1-383-607-660-3

CARD CODE

NEXT SHEET	
SHEET No.	1
REV.	0

GENERAL NOTES :-
 1. FOR GENERAL NOTES REFER DWG.NO. TB-1-383-607-660-1

NOTES :-
 PROVIDING AND LAYING PROOFING TREATMENT OVER ROOFS CONSISTING OF FIRST, THIRD AND FIFTH COURSES OF BLOWN OR/AND BITUMIN APPLIED HOT; SECOND, FOURTH COURSES OF HESSIAN BASED FELT AND FINAL COURSES OF WHITE STONE AGGREGATES 6MM AND DOWN SIZE INCLUDING PREPARATION OF SURFACE, EXCLUDING GRADING, COMPLETE.

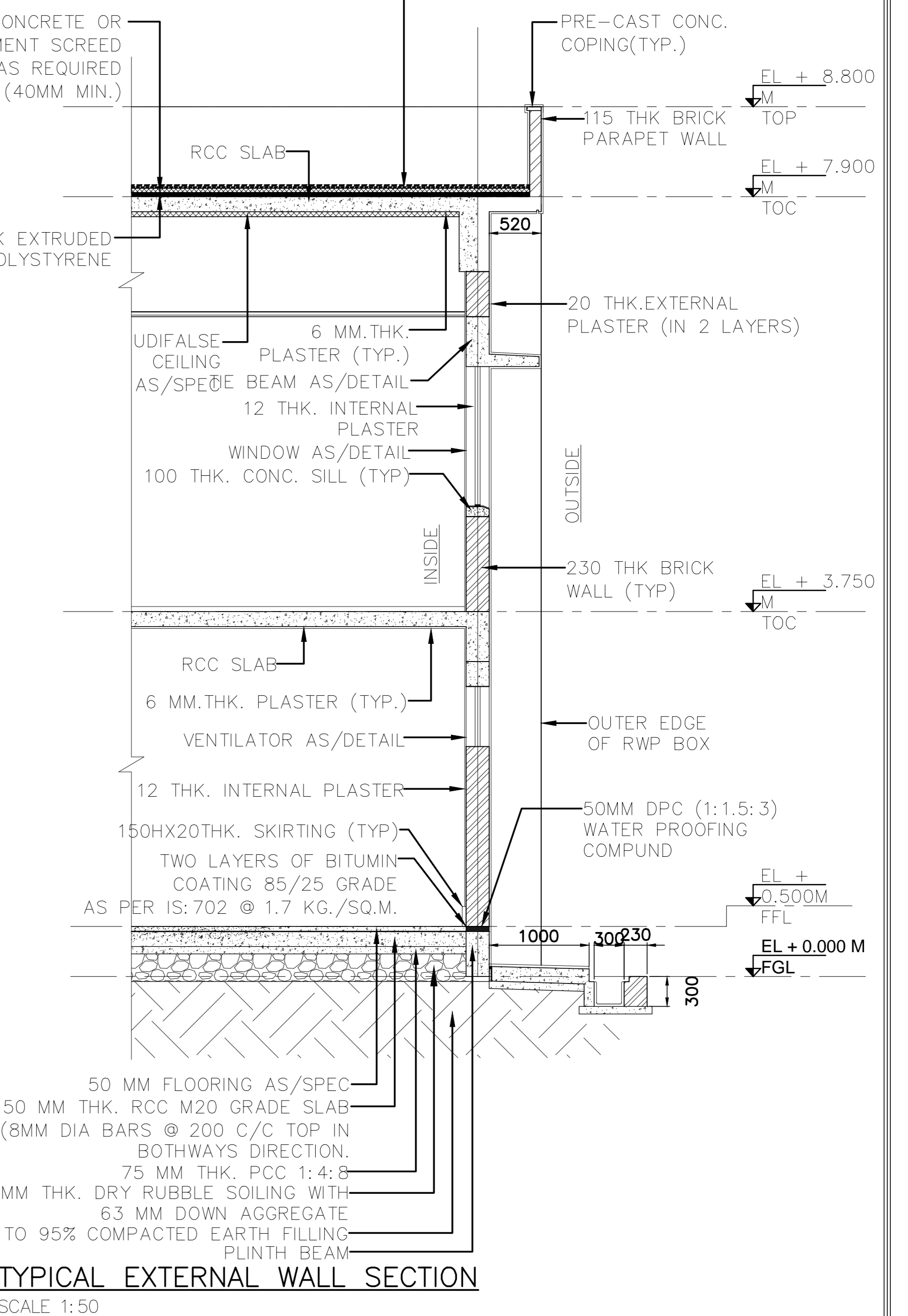
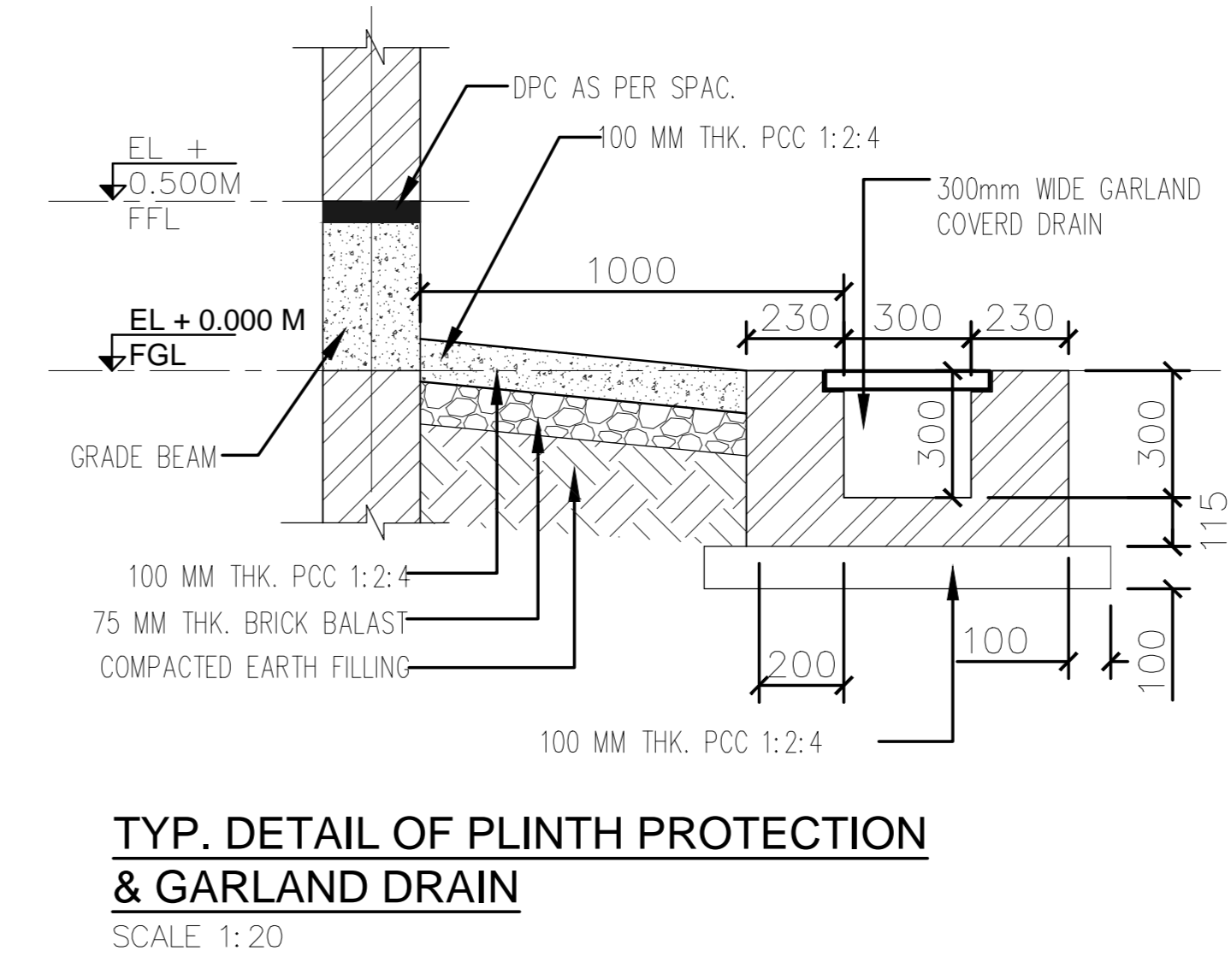
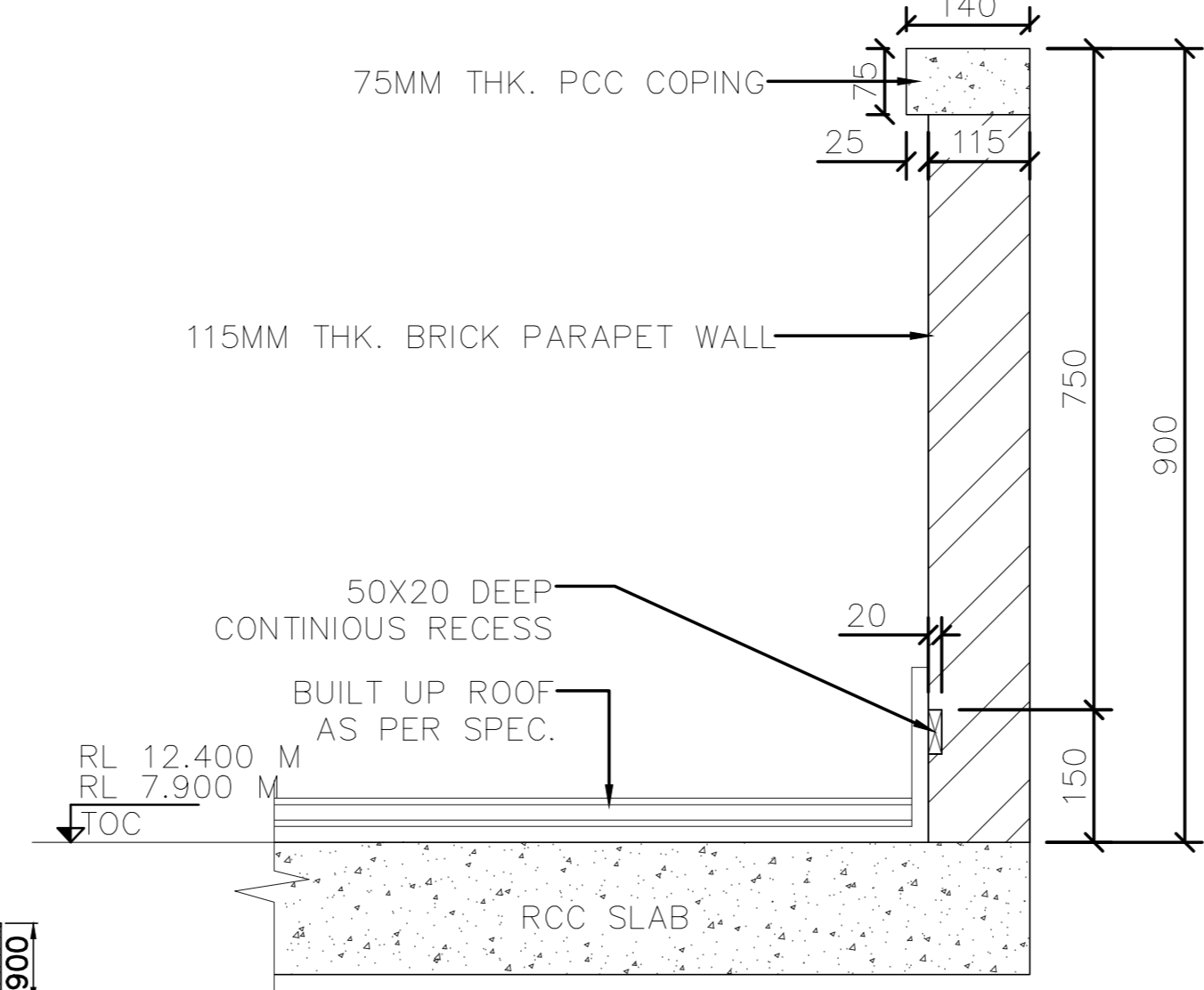
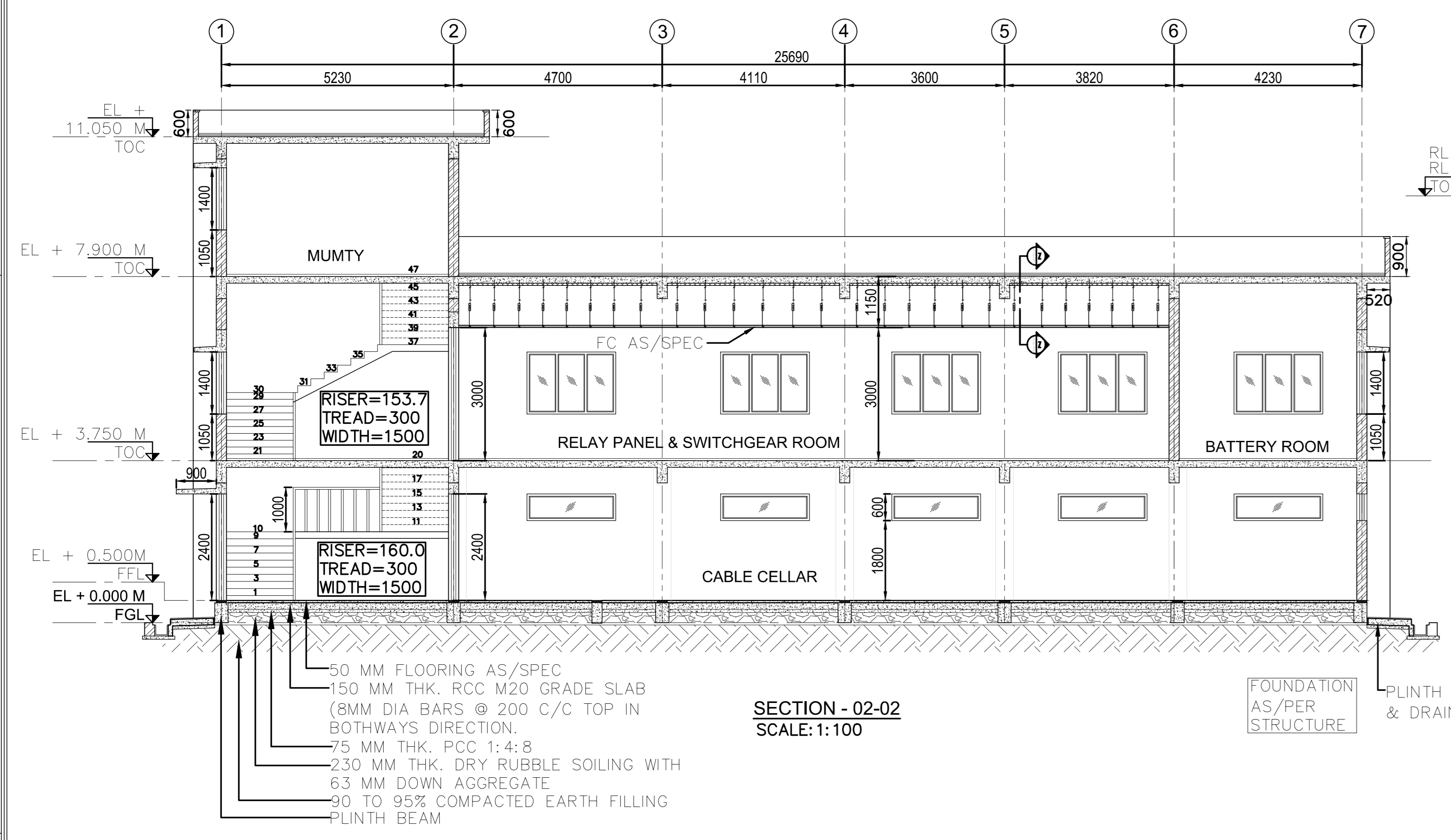
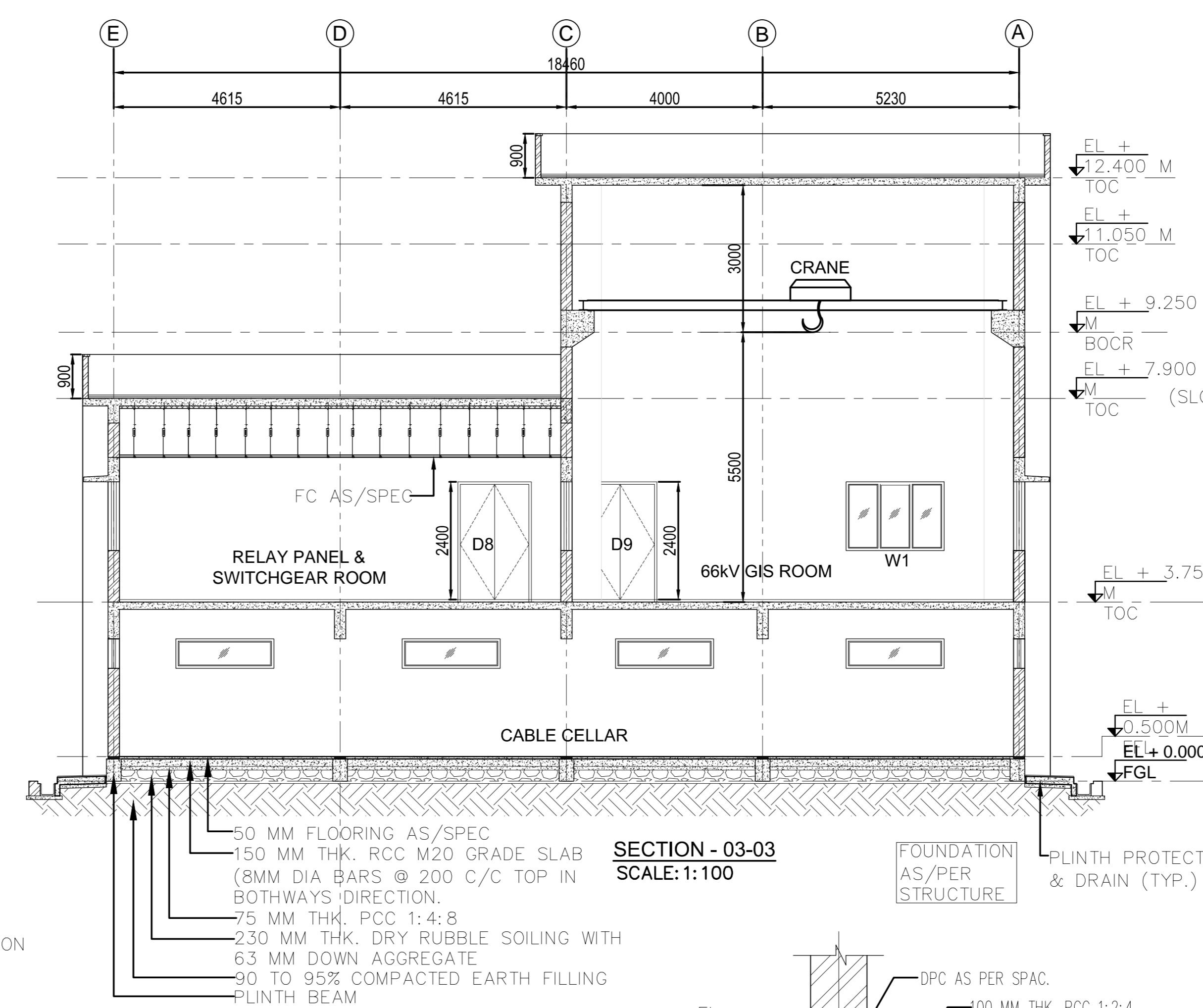
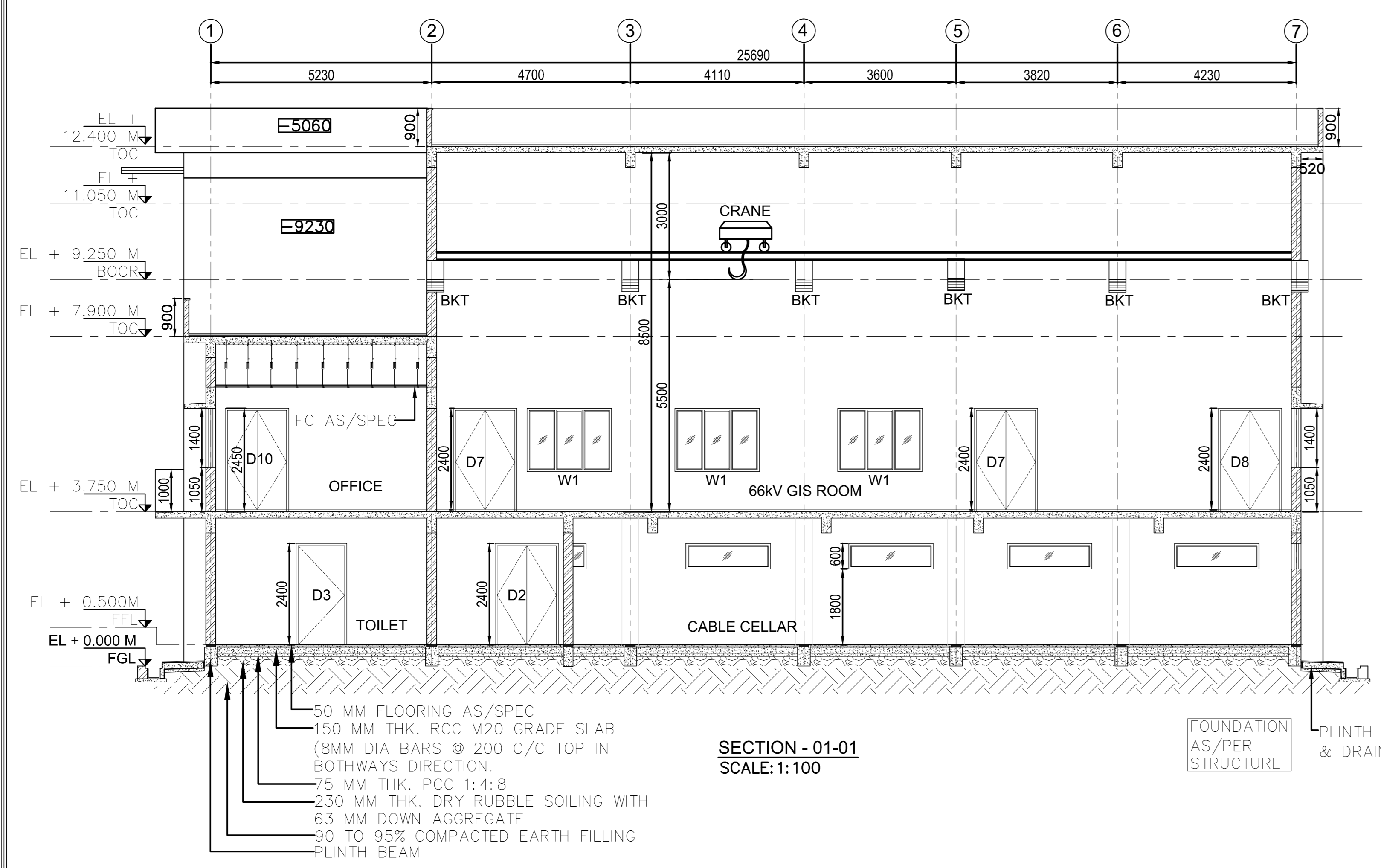

LEGEND :-

EL	ELEVATION
RL	REDUCED LEVEL
FGL	FINISHED GROUND LEVEL
TRL	TOP OF ROAD
FFL	FINISHED FLOOR LEVEL
BOB	BOTTOM OF BEAM
TOC	TOP OF CONCRETE
TOP	TOP OF PARAPET WALL
PCC	PLAIN CEMENT CONCRETE
TRL	TOP OF ROAD
AC+FC	AIR COND. AND FALCE CEILING
UDI	UNDER DECK INSULATION
BFC	BOTTOM OF FALSE CEILING
DPC	DAMP PROOF COURSE
WPC	WATER PROOF COURSE
D	DOOR
W	WINDOW
EF	EXHAUST FAN
WB	WASH BASIN
CI	CAST IRON
RWP	RAIN WATER PIPE
BOCR	BOTTOM OF CRANE

NAME OF PROJECT/CUSTOMER: OIL AND NATURAL GAS CORPORATION LTD.
 COMBINED CYCLE CAPTIVE POWER PLANT AT HAZIRA UNIT, GUJARAT

NAME OF CONSULTANT: FITCHNER CONSULTING ENGINEERS INDIA PVT LTD

BHARAT HEAVY ELECTRICALS LIMITED
 TRANSMISSION BUSINESS GROUP

DEVELOPMENT CONSULTANTS PVT. LTD.
 CONSULTING ENGINEERS
 KOLKATA *MUMBAI CHENNAI NEW DELHI

TITLE: SECTIONS FOR 66kV GIS BUILDING

SCALE 1:100 W.O. No 80003

DRG. No. TB-1-383-607-660-3

REV.	DATE	ALTD.	CHD.	APPD.	REV.	DATE	ALTD.	CHD.	APPD.	NAME	SIGN.	DATE
										DRAWN		16.06.16
										CHECKED		
										APPROVED		
DISTRIBUTION OF PRINTS										DEPT.	CODE	
										TBEM	422	

CARD CODE	
NEXT SHEET	
SHEET No.	2
REV.	0

COPY RIGHT AND CONFIDENTIAL
 The information on this document is the property of BHARAT HEAVY ELECTRICALS LIMITED it must not be used directly or indirectly in anyway detrimental to the interest of the company.

COMPUTER DRG. PATH NAME :

SIGN & DATE

INVENTORY NO

MANUFACTURING QUALITY PLAN													
		TBG BHEL NOIDA		PROJECT : ONGC - HAZIRA CONSULTANT : FICHTNER CONSULTING ENGINEERS (I) PVT LTD, BANGALORE		PRODUCT : EOT CRANE		QP. NO.: MQAP/MP/KPP/008					
		SUB ITEM : -- BHEL SPEC.: AS PER PO		REFERENCE DOCUMENT		ACCEPTANCE NORMS		REV NO: 00 DATE: 12.03.2016					
SL NO	COMPONENTS	CHARACTERISTICS	CLASS	TYPE OF CHECK	QUANTUM OF CHECK	REFERENCE DOCUMENT	ACCEPTANCE NORMS	FORMAT OF RECORD	* D	AGENCY		REMARKS	
1.0 RAW MATERIALS & BOUGHT OUT ITEMS													
1.1	Structure Material for Bridge Girder, End Carriage & Trolley Frame	Visual & Dimensional Inspection Chemical & Mechanical Properties	Major	Visual & Measurement UT, Chemical & Physical	100% / Sample	Apprd. Drg./ Data sheet/ Tech Spec	Apprd. Drg./ Data sheet/ Tech Spec	IR MTC	√	2	-	1	UT For plate thick more than 50 mm
1.2	Rope drum if seamless pipe	NDT& Chemical	Major	UT& Chemical	100% / Sample	Apprd. Drg./ Data sheet/ Tech Spec	Apprd. Drg./ Data sheet/ Tech Spec	TC	√	2	-	1	
1.3	i) Rods for Pinion, Shaft ii) Forging for Gear, Wheel	Visual & Dimensional Inspection Chemical Properties & NDT Hardness	Major	Visual & Measurement UT & Chemical Hardness	100% / Sample	Apprd. Drg./ Data sheet/ Tech Spec	Apprd. Drg./ Data sheet/ Tech Spec	IR TC	√	2	-	1	

LEGEND: P: PERFORM, W: WITNESS, V: VERIFICATION. INDICATE 1 FOR BHEL CQS (OR BHEL NOMINATED INSPECTION AGENCY) & 2 FOR VENDOR/SUB VENDOR AS APPROPRIATE AGAINST EACH COMPONENT /CHARACTERISTIC UNDER P, W & V COLUMNS. * FOR ITEMS MARKED ✓ (TICK) IN COLUMN 'D', TEST CERTIFICATES SHALL BE SUBMITTED TO BHEL FOR RECORDS.	PREPARED BY 	APPROVED BY _____
		CUSTOMER'S SIGNATURE & STAMP

MANUFACTURING QUALITY PLAN									
		TBG BHEL NOIDA S		PROJECT : ONGC - HAZIRA CONSULTANT : FICHTNER CONSULTING ENGINEERS (I) PVT LTD, BANGALORE		PRODUCT : EOT CRANE SUB ITEM : -- BHEL SPEC : AS PER PO		QP. NO.: MQAP/MP/KPP/008 REV NO: 00 DATE: 12.03.2016 PAGE 2 OF 5	
		SL NO	COMPONENTS	CHARACTERISTICS	CLASS	TYPE OF CHECK	QUANTUM OF CHECK	REFERENCE DOCUMENT	ACCEPTANCE NORMS

SL NO	COMPONENTS	CHARACTERISTICS	CLASS	TYPE OF CHECK	QUANTUM OF CHECK	REFERENCE DOCUMENT	ACCEPTANCE NORMS	FORMAT OF RECORD	AGENCY	REMARKS
1.4	Hook	Chemical / Physical Properties ,NTD & proof load test	Major	Chemical & UT&Magnetic particle test after and before proof load test.	Sample 100%	Apprd. Drg./ Data sheet/ Tech Spec	Apprd. Drg./ Data sheet/ Tech Spec	TC	2 - 1	
1.5	Wire Rope	Size Destructive Test, Proof load test & Dimension	Major	Dimensions Destructive Test	As Per IS	Apprd. Drg./ Data sheet/ Tech Spec	Apprd. Drg./ Data sheet/ Tech Spec	TC	2 - 1	
1.6	Bearings	Visual	Major	Test report	100%	Apprd. Drg./ Data sheet/ Tech Spec	Apprd. Drg./ Data sheet/ Tech Spec	TC	2 - 1	
1.7	Motors	Verification of Rating	Major	Routine Test& Type test Report	100%	Apprd. Drg./ Data sheet/ Tech Spec	Apprd. Drg./ Data sheet/ Tech Spec	TC	2 - 1	

LEGEND: P: PERFORM, W: WITNESS, V: VERIFICATION. INDICATE 1 FOR BHEL CQS (OR BHEL NOMINATED INSPECTION AGENCY) & 2 FOR VENDOR/SUB VENDOR AS APPROPRIATE AGAINST EACH COMPONENT /CHARACTERISTIC UNDER P, W & V COLUMNS. *FOR ITEMS MARKED ✓ (TICK) IN COLUMN 'D', TEST CERTIFICATES SHALL BE SUBMITTED TO BHEL FOR RECORDS.		APPROVED BY	CUSTOMER'S SIGNATURE & STAMP
--	--	-------------	------------------------------

MANUFACTURING QUALITY PLAN																			
		TBG BHEL NOIDA S,		PROJECT : ONGC - HAZIRA CONSULTANT : FICHTNER CONSULTING ENGINEERS (I) PVT LTD, BANGALORE		PRODUCT : EOT CRANE SUB ITEM : -- BHEL SPEC : AS PER PO		QP. NO.: MQAP/MP/KPP/008 REV NO: 00 DATE: 12.03.2016 PAGE 3 OF 5											
				COMPONENTS	CHARACTERISTICS	CLASS	TYPE OF CHECK	QUANTUM OF CHECK	REFERENCE DOCUMENT	ACCEPTANCE NORMS	FORMAT OF RECORD	* D							
SL NO																			

1.8	Brake & Limit switch	Visual	Major	Routine test Report	100%	Apprd. Drg./ Data sheet/ Tech Spec	Apprd. Drg./ Data sheet/ Tech Spec	TC	√	2	-	1							
2.0	INPROCESS INSPECTION																		
2.1	Bridge Girders	Visual/Dimensions	Major	RT	100%	Apprd. Drg./ Data sheet/ Tech Spec	Apprd. Drg./ Data sheet/ Tech Spec	IIR / RT report	√	2	-	1							
2.2	End Carriage	Radiography for Butt joint	Major	Visual/Dime nsions DP	100%	Apprd. Drg./ Data sheet/ Tech Spec	Apprd. Drg./ Data sheet/ Tech Spec	IIR / DP report	√	2	-	1							
		Visual/Dimensions NDT																	
2.3	Gear Box Housing	Oil leakage	Major	Oil Leakage test	Major	Apprd. Drg./ Data sheet/ Tech Spec	Apprd. Drg./ Data sheet/ Tech Spec	IIR report	√	2	-	1							
2.4	Welding	Welder Qualification, WPS	Major	Verification	100%	Apprd. Drg./ Data sheet/ Tech Spec	Apprd. Drg./ Data sheet/ Tech Spec	WPS, PQR	√	2	-	1							

LEGEND: P: PERFORM, W: WITNESS, V: VERIFICATION. INDICATE 1 FOR BHEL CQS (OR BHEL NOMINATED INSPECTION AGENCY) & 2 FOR VENDOR/SUB VENDOR AS APPROPRIATE AGAINST EACH COMPONENT /CHARACTERISTIC UNDER P, W & V COLUMNS. * FOR ITEMS MARKED ✓ (TICK) IN COLUMN 'D', TEST CERTIFICATES SHALL BE SUBMITTED TO BHEL FOR RECORDS.		APPROVED BY	CUSTOMER'S SIGNATURE & STAMP
---	--	-------------	------------------------------

MANUFACTURING QUALITY PLAN									
		TBG BHEL NOIDA S		PROJECT : ONGC - HAZIRA CONSULTANT : FICHTNER CONSULTING ENGINEERS (I) PVT LTD, BANGALORE		PRODUCT : EOT CRANE SUB ITEM : -- BHEL SPEC : AS PER PO		QP. NO.: MQAP/MP/KPP/008 REV NO: 00 DATE: 12.03.2016 PAGE 4 OF 5	
		SL NO	COMPONENTS	CHARACTERISTICS	CLASS	TYPE OF CHECK	QUANTUM OF CHECK	REFERENCE DOCUMENT	ACCEPTANCE NORMS

3.0	FINAL INSPECTION & TESTING												
3.1	Crane	Dimensions check for assembled crane & Free running of all motion. Speed and current all motion at no load .load test SWL and deflection test, & 125% of over load test for hoist and cross travel.	Major	Measurement Testing	100%	Apprd. Drg./ Data sheet/ Tech Spec	Apprd. Drg./ Data sheet/ Tech Spec	IIR report	√	2	1	-	
3.2		Include HV,IR Correctness of wiring & continuity check ,BOM check	Major	Testing	100%	Apprd. Drg./ Data sheet/ Tech Spec	Apprd. Drg./ Data sheet/ Tech Spec	Report	√	2	1	-	
4.0	PRESERVATION & PACKING												
4.1	Painting	Visual/shade, Peel off test	Major	Visual Measure Test	100%	Apprd. Drg./ Data sheet/ Tech Spec	Apprd. Drg./ Data sheet/ Tech Spec	IR		2	1	-	
4.2	Name Plate Fixing	Visual	Major	Visual	100%	Apprd. Drg./ Data sheet/ Tech Spec	Apprd. Drg./ Data sheet/ Tech Spec	Test Certificate		2	1	-	

LEGEND: P: PERFORM, W: WITNESS, V: VERIFICATION. INDICATE 1 FOR BHEL CQS (OR BHEL NOMINATED INSPECTION AGENCY) & 2 FOR VENDOR/SUB VENDOR AS APPROPRIATE AGAINST EACH COMPONENT /CHARACTERISTIC UNDER P, W & V COLUMNS. * FOR ITEMS MARKED ✓ (TICK) IN COLUMN 'D', TEST CERTIFICATES SHALL BE SUBMITTED TO BHEL FOR RECORDS.		APPROVED BY	CUSTOMER'S SIGNATURE & STAMP
---	--	-------------	------------------------------

MANUFACTURING QUALITY PLAN										
		PROJECT : ONGC - HAZIRA		PRODUCT : EOT CRANE		QP. NO.: MQAP/MP/KPP/008		REV NO: 00		DATE: 12.03.2016
		CONSULTANT : FICHTNER CONSULTING ENGINEERS (I) PVT LTD, BANGALORE		SUB ITEM : -- BHEL SPEC: AS PER PO		ACCEPTANCE NORMS		* D		PAGE 5 OF 5
SL NO	COMPONENTS	CHARACTERISTICS	CLASS	TYPE OF CHECK	QUANTUM OF CHECK	REFERENCE DOCUMENT	FORMAT OF RECORD	AGENCY		REMARKS
								P	W	V

4.3	Packing	Packing	Major	Visual	100%	Appd drg /data sheet /Tech spec	Appd drg /data sheet /Tech spec		2	-	1
							Packing list				

NOTE:-

1. This MQP should be read along with specification (latest revision), approved drawings & approved data sheet.
2. Drawing/data sheet shall prevail over quality plan for contradiction if any between quality plan and drawing/specification.
3. All test certificates/reports reviewed and certified by TPI/BHEL shall be submitted to BHEL as documentation package.
4. Any project/customer specific requirements which shall be notified have to be fulfilled by the vendor at the time of execution of order.

ABBREVIATIONS:-

MOC: Material of Construction	WPS: Welding Procedure Specification	BOM: Bill Of Material
PQR: Procedure Qualification Record	WQR: Welder Qualification Record	IR : Inspection Report
DFT: Dry Film Thickness	BOI: Bought Out Items	

LEGEND: P: PERFORM, W: WITNESS, V: VERIFICATION. INDICATE 1 FOR BHEL CQS (OR BHEL NOMINATED INSPECTION AGENCY) & 2 FOR VENDOR/SUB VENDOR AS APPROPRIATE AGAINST EACH COMPONENT /CHARACTERISTIC UNDER P, W & V COLUMNS. * FOR ITEMS MARKED ✓ (TICK) IN COLUMN 'D', TEST CERTIFICATES SHALL BE SUBMITTED TO BHEL FOR RECORDS.		APPROVED BY
		CUSTOMER'S SIGNATURE & STAMP