

1X800 MW KOTHAGUDEM TPS

VOLUME IIB

**TECHNICAL SPECIFICATION FOR
IP BASED PUBLIC ADDRESS SYSTEM**

DOC. NO. PE-TS-410-557-E001, REV00



BHARAT HEAVY ELECTRICALS LIMITED

POWER SECTOR

PROJECT ENGINEERING MANAGEMENT

NOIDA, INDIA



TECHNICAL SPECIFICATION FOR
IP BASED PUBLIC ADDRESS SYSTEM

SPECIFICATION NO. PE-TS-410-557-E001

VOLUME II B

SECTION

1X800 MW KOTHAGUDEM TPS

REVISION
0

DATE 19.10.2015

CONTENTS

Sl. No.	DESCRIPTION	NO. OF SHEETS
1.	INSTRUCTIONS TO BIDDERS FOR PREPARING TECHNICAL OFFER	02
2.	PREAMBLE	01
3.	SECTION – ‘A’ SCOPE OF ENQUIRY	02
4.	SECTION – ‘B’ PROJECT INFORMATION	02
5.	SECTION – ‘C’ SPECIFIC TECHNICAL REQUIREMENTS (INCLUDING DATASHEET-A)	38
6.	ANNEXURE- 1 ZONE WISE DISTRIBUTION OF HANDSET STATIONS	02
7.	ANNEXURE –2 PLOT PLAN AND CHP SCHEME	02
8.	ANNEXURE –3 SUPPLY UNPRICED SCHEDULE	07
9.	ANNEXURE –4 E&C PRICE SCHEDULE	04
10.	ANNEXURE –5 DRG./ DOCUMENT DISTRIBUTION LIST	01
11.	PA SYSTEM [LIST OF DOCUMENTS AND NUMBERING]	01
12.	SYSTEM BLOCK DIAGRAM FOE PA SYSTEM	02
13.	SECTION – ‘D’ STANDARD TECHNICAL REQUIREMENTS	8
14.	DATASHEET -B	5
15.	DATA SHEET – C	11
16.	QUALITY PLAN	11
	TOTAL NO. OF SHEETS (INCLUDING COVER/SEPARATOR SHEETS)	= 102

BIDDER'S STAMP & SIGNATURE

(REFER INSTRUCTION NO. 1 OF 'INSTRUCTIONS TO BIDDERS FOR PREPARING TECHNICAL OFFER')



TECHNICAL SPECIFICATION FOR
IP BASED PUBLIC ADDRESS SYSTEM

SPECIFICATION NO. PE-TS-410-557-E001

VOLUME II B

SECTION

1X800 MW KOTHAGUDEM TPS

REVISION 0 DATE 19.10.2015

SHEET OF

INSTRUCTIONS TO BIDDERS FOR PREPARING TECHNICAL OFFERS

1. Two signed and stamped copies of the following shall be furnished by all bidders as technical offer :
 - a. Unpriced Price Schedule with bidder's signature and company stamp.
 - b. Datasheet-A (Clause no. 8.11.00 to 8.19.00 of Sec-C of this specification)
 - c. A copy of this sheet ("Instructions to Bidders for Preparing Technical Offer"), with bidder's signature and company stamp.
 - d. A copy of previous sheet ("List of Contents"), with bidder's signature and company stamp.
 - e. Necessary information about the financial and technical resources, organization and experience to undertake the manufacturing and supply of such equipment shall be supplied by Bidder as an evidence of his capability for satisfaction of the Owner. Bidder shall submit along with his Bid a list of major contracts of supply and erection of similar equipment already executed or under execution, giving detailed particulars such as equipment rating, contract value, name of the Owner, year of supply etc.
 - f. In case of discrepancies between the technical requirements and other applicable Engineering Standards, Materials System Specifications, Standard Drawings, or industry standards, codes, and forms shall be resolved in writing by Bidder with the employer. Before starting the manufacturing/supply, Bidder shall inform employer of any discrepancy between the instructions of the present specification and Bidder's standard.
 - g. Following documents are required to be furnished

SL. NO.	DOCUMENT TYPE
01.	Supply Document list
02.	Supply program
03.	Data sheets
04.	Technical specifications and relevant drawings
05.	Start-up, Mandatory and Recommended spare parts
06.	List of Tools and Tackle
07.	Proposed System schematic diagram.
08.	Write up on architecture and operation of proposed system
09.	BILL OF MATERIALS with make and model no. of equipment
10.	Power requirement. (capacity of FCBC and SMF battery)
11.	Quality Control Plan

2. No technical submittal such as copies of type test certificates, data Sheets, write-up, drawing, technical literature, etc. is required during tender stage. Any such submission, even if made, shall not be considered as part of offer.



TECHNICAL SPECIFICATION FOR
IP BASED PUBLIC ADDRESS SYSTEM

1X800 MW KOTHAGUDEM TPS

SPECIFICATION NO. PE-TS-410-557-E001

VOLUME II B

SECTION

REVISION 0 | DATE 19.10.2015

SHEET OF

3. No comments/ additions/ deletions shall be made by the bidder on the signed & stamped copy of the specification. Any such changes made by the bidder shall not be considered.
4. Confirmations/ comments (if any) regarding delivery schedules shall be furnished as part of the commercial offer. Any reference elsewhere/ covering letter of technical offer shall not be considered by BHEL.
5. Any comments/ clarifications on technical/ inspection requirements furnished as part of bidder's covering letter shall not be considered by BHEL, and bidder's offer shall be construed to be in conformance with the specification.
6. Any changes made by the bidder in the price schedule with respect to the PUBLIC ADDRESS SYSTEM description/ quantities, notes etc. from those given in Annexure- 3&4 of Section-C of specification [Bill Of Quantities] shall not be considered (i.e., technical description, quantities, notes etc. as per specification shall prevail).

BIDDER'S STAMP & SIGNATURE



TECHNICAL SPECIFICATION FOR
IP BASED PUBLIC ADDRESS SYSTEM

SPECIFICATION NO. PE-TS-410-557-E001

VOLUME II B

SECTION

1X800 MW KOTHAGUDEM TPS

REVISION 0 DATE 19.10.2015

PREAMBLE

- 1 The Tender documents contain three (3) volumes. The bidder shall meet the requirements of all three volumes.
- 1.1 **VOLUME - I** **CONDITIONS OF CONTRACT**
- This consists of four parts as below:
- Volume – IA** This part contains Instructions to bidders for making bids to BHEL.
- Volume – IB** This part contains General Commercial Conditions of the Tender & includes provision that vendor shall be responsible for the quality of item supplied by their sub-vendors.
- Volume – IC** This part contains Special Conditions of Contract.
- Volume – ID** This part contains Commercial Conditions for Erection & Commissioning site work, as applicable.
- 1.2 **VOLUME – II** **TECHNICAL SPECIFICATIONS**
- Technical requirements are stipulated in Volume – II, which comprises of:-
- Volume – IIA** General Technical Conditions.
- Volume – IIB** Technical Specification including Drawings, if any.
- 1.3 **VOLUME – IIB**
- This volume is sub-divided in to following sections:-
- Section – A:** This section outlines the Intent of Specification.
- Section – B:** This section provides “Projection Information”.
- Section – C:** This section indicates Technical Requirements specific to Contract, not covered in Section – D.
- Section – D:** This section comprises of Technical Specifications of equipment complete with Data Sheet A and Data Sheet C.
- Data sheet–C:** Indicates data / documents to be furnished after the award of Contract as per agreed schedule by the vendor (as applicable)
- 1.4 **VOLUME – III** **TECHNICAL SCHEDULES (NOT APPLICABLE)**
- This volume contains Technical Schedule and Data Sheets–B, which are to be duly filled by bidder and the same shall be furnished with the technical bid.
- 2.0 In case of clash of requirement between section-C, Annexure-3, 4 and Section-D, the requirement in Annexure-3, 4 & Section-C shall prevail.



TECHNICAL SPECIFICATION FOR
IP BASED PUBLIC ADDRESS SYSTEM

SPECIFICATION NO. PE-TS-410-557-E001

VOLUME II B

SECTION A

1X800 MW KOTHAGUDEM TPS

REVISION 0 | DATE 19.10.2015

SECTION – 'A'
SCOPE OF ENQUIRY



TECHNICAL SPECIFICATION FOR
IP BASED PUBLIC ADDRESS SYSTEM

SPECIFICATION NO. PE-TS-410-557-E001

VOLUME II B

SECTION A

1X800 MW KOTHAGUDEM TPS

REVISION 0 | DATE 19.10.2015

SCOPE OF ENQUIRY

1. This specification covers design, manufacture, assembly, inspection & testing at manufacturer's works, proper packing, delivery to **(1X800 MW KOTHAGUDEM TPS)** site, site unloading/ handling, system engineering and erection & commission of Public Address System as mentioned in different sections of this specification, complete with all accessories for efficient and trouble-free operation of project.
2. It is not the intent to specify completely herein all details of the design and manufacture. However, the equipment shall conform in all respects to high standards of design engineering and workmanship and shall be capable of performing in continuous commercial operation up to bidder's guarantee.
3. The general terms and conditions, instruction to bidders and other attachment referred to elsewhere are hereby made part of the Technical Specification.
4. The Bidder shall be responsible for and governed by all requirements stipulated hereinafter.
5. The offer should be complete with technical data, catalogue, brochures and drawings as applicable.
6. Qualification data: In order to be able to present to the client the proven-ness of the equipment offered, the bidder is required to elaborate details of experience, capabilities, reference list etc. in the offer.
7. The documents shall be in English language and MKS system of units.
8. Bidder shall quote for all type of PA system items as per specification, failing which their offer shall be rejected.
9. For every shipment made to site, a shipping list containing item reference (item no. & description as per specification Bill of material of package drawing) and quantity of the same (nos.) shall be provided by the vendor at the time of dispatch of material to site.



TECHNICAL SPECIFICATION FOR
IP BASED PUBLIC ADDRESS SYSTEM

SPECIFICATION NO. PE-TS-410-557-E001

VOLUME II B

SECTION B

1X800 MW KOTHAGUDEM TPS

REVISION 0

DATE 19.10.2015

SECTION – ‘B’
PROJECT INFORMATION

SECTION - B

PROJECT SYNOPSIS AND GENERAL INFORMATION

1.00.00 INTRODUCTION

The proposed 1x800 MW Kothagudem Thermal Power Station (KTPS), Stage-VII, Unit-12 would be set up by Telangana State Power Corporation Ltd. (TSGENCO) at Kothagudem, Telangana. The proposed Power Plant will be installed adjacent to the existing D colony of Kothagudem Thermal Power Station, at Kothagudem.

The Bidder shall acquaint himself by a visit to the site, if felt necessary, with the conditions prevailing at site before submission of the bid. The information given here in under is for general guidance and shall not be contractually binding on the Owner. All relevant site data /information as may be necessary shall have to be obtained /collected by the Bidder.

2.00.00 APPROACH TO SITE

Site is located in the existing D Colony of Kothagudem Thermal Power Station, which is at a distance 30 km from temple town of Bhadrachalam and 300 km from Hyderabad by road. The Nearest railway station is Bhadrachalam Road (Known as Kothagudem) at a distance of 12 km. Kothagudem-Bhadrachalam National Highway branches off to the power station site near village Paloncha.

3.00.00 LAND

Land is primarily required for the main plant & auxiliaries (BTG) and balance of plant (BOP) like ash handling, coal storage, cooling tower, switchyard etc., which is available within the existing plant boundary.

The existing colony is to be dismantled, and the land of about 137 acres will be used for the main plant building, water facilities, switchyard, coal handling etc. The raw water reservoir will be located adjacent to the existing raw water reservoirs.

230 acres of land required for Ash Dyke will be procured. Land is available for staff colony, which is to be constructed by the EPC contractor.

4.00.00 SOURCE OF COAL

100% Imported and Blended coal (50% imported + 50% indigenous) will be used. Indigenous coal shall be sourced from Suliyari coal mines, Madhya Pradesh.

5.00.00 SOURCE OF WATER

Source of water (total quantity of water is 2192 m³/hr) is Godavari River near Burgampahad & water will be pumped through existing GRP pipe line (of length approx. 26 km).

6.00.00 ASH DISPOSAL AREA

Ash shall be dumped in the ash dump area which will be about 9 km from plant. The ash dyke area of 230 acres is adequate for 1x800 MW unit as per MOEF norms.

7.00.00 SALIENT DESIGN DATA

Meteorological data of site is given below:-

Elevation above MSL : 89 m

Monthly highest temperature : 44.9 °C

Monthly lowest temperature. : 12.9 °C

Rainfall

Average.: 1031 mm

Max. : 100 mm/ hr

Mean Wind speed : 5.8 kmph

Relative Humidity

Max : 82%

Min : 35%

Seismic Zone : Zone-III as per IS- 1893 (Part-IV)



TECHNICAL SPECIFICATION FOR
IP BASED PUBLIC ADDRESS SYSTEM

SPECIFICATION NO. PE-TS-410-557-E001

VOLUME II B

SECTION : C

1X800 MW KOTHAGUDEM TPS

REVISION 0

DATE 19.10.2015

SECTION – 'C'

SPECIFIC TECHNICAL REQUIREMENT

	TECHNICAL SPECIFICATION FOR IP BASED PUBLIC ADDRESS SYSTEM	SPECIFICATION NO. PE-TS-410-557-E001	
		VOLUME II B	
		SECTION - C	
	1X800 MW KOTHAGUDEM TPS	REVISION 0	DATE 19.10.2015

INDEX

<u>CLAUSE NO.</u>	<u>DESCRIPTION</u>
1.00.00	INTENT OF SPECIFICATION
2.00.00	ABBREVIATIONS
3.00.00	SCOPE OF WORK AND EXCLUSIONS
4.00.00	PERFORMANCE GUARANTEE
5.00.00	WORK SCHEDULE
6.00.00	REFERENCE DOCUMENTS' CODES AND STANDARDS
7.00.00	PROJECT INFORMATION
8.00.00	TECHNICAL DESCRIPTION
9.00.00	ERECTION AND COMMISSIONING
10.00.00	DOCUMENTATION
11.00.00	TESTING
12.00.00	MAINTENANCE REQUIREMENTS
13.00.00	SPARES, TOOLS AND TEST EQUIPMENT
14.00.00	CLEANING, PROTECTION AND PAINTING
15.00.00	IDENTIFICATION, MARKING, PACKING AND STORING
16.00.00	SHIPMENT
17.00.00	QUALITY ASSURANCE PLAN



TECHNICAL SPECIFICATION FOR
IP BASED PUBLIC ADDRESS SYSTEM

SPECIFICATION NO. PE-TS-410-557-E001

VOLUME II B

SECTION - C

1X800 MW KOTHAGUDEM TPS

REVISION 0

DATE 19.10.2015

1.00.00 INTENT OF SPECIFICATION

- 1.00.01 This specification covers the design, manufacture, assembly, testing and inspection at vendor's/sub-vendor's works, packing, despatch to site, site unloading/handling, system engineering and erection & commissioning of IP based Public Address System as described in the various sections of this specification. It is not the intent to completely specify all details of design and construction herein. However, the equipment shall conform to acceptable standards of design, engineering and workmanship and shall be capable of performing the required duties in a manner acceptable to purchaser, who shall be entitled to reject any work or materials, which in his opinion is not in conformity with the duty requirements.
- 1.00.02 The PA system covered herein shall also include site unloading, handling, intra site transportation, site storage, complete erection, final check -up, testing and commissioning and all other incidental works thereto (like labour, supervision, supply of erection equipment and consumables as necessary) of the equipment and accessories to be supplied under this specification as specified here under.
- 1.00.03 It is not the intent to completely specify all details of design and construction herein. Nevertheless, the system shall conform to high standard of engineering, design and workmanship in all respects and shall be capable of performing satisfactorily in continuous commercial operation under the specified environmental condition.

2.00.00 ABBREVIATION

- BOQ - Bill of Quantities
- CCB - Central Control Building
- CCR - Central Control Room
- DCS - Distributed Control System
- DVSP - Digital Voice Storage Playback
- GCC - General Conditions of Contract
- LED - Light Emitting Diode
- LOI - Letter Of Intent
- MDF - Main Distribution Frame
- MTTR - Mean Time To Repair
- PA - Public Address
- PABX - Private Automatic Branch Exchange
- PC - Personal Computer
- QAP - Quality Assurance Plan
- RH - Relative Humidity
- RMS - Root Mean Square
- SPL - Sound Pressure Level
- UCR - Utilities Control Room
- UHF - Ultra High Frequency



TECHNICAL SPECIFICATION FOR
IP BASED PUBLIC ADDRESS SYSTEM

SPECIFICATION NO. PE-TS-410-557-E001

VOLUME II B

SECTION - C

1X800 MW KOTHAGUDEM TPS

REVISION 0

DATE 19.10.2015

- UPS - Uninterruptible Power Supplies

3.00.00 SCOPE OF WORK

3.01.00 GENERAL

- 3.01.01 The scope of work in this document specifies the technical & contractual requirements for the design, supply, erection, testing and commissioning of IP Public Address and Paging System and its accessories for the Project as "turn-key" plant-wide stand-alone package unit with suitable interfaces as specified.
- 3.01.02 Bidder shall be fully responsible for both the products and their relevant compliance with the requirements of the specification.
- 3.01.03 Provisions included in the specification will not be limitative to the scope of work.
- 3.01.04 Bidder shall provide for any further activities which will improve the quality & performance of the system offered.
- a) Tentative equipment type & location of Public Address System is listed in the Annexure-1.
- b) Bidder shall indicate the unit price for each type and size of equipment/items as per unpriced schedules enclosed with specification.
- 3.01.05 Necessary information about the financial and technical resources, organization and experience to undertake the manufacturing and supply of such equipment shall be supplied by Bidder as an evidence of his capability for satisfaction of the Owner. Bidder shall submit along with his Bid a list of major contracts of supply and erection of similar equipment already executed or under execution, giving detailed particulars such as equipment rating, contract value, name of the Owner, year of supply etc.

3.02.00 INCLUSION IN SUPPLY

Bidder's scope of supply shall include but shall not be limited to following.

01. Plant IP Public Address & Paging System with all accessories specified herein/Data sheet and other Technical Attachment Sheets.
02. Development, supply & installation of required software for the total system.
03. Uninterruptible Power Supply System to cater to the entire system load.
04. Associated copper, Cat6 and fibre optic cable for interconnection.
05. Necessary erection hardwares.
06. Recommended spares for 3 (three) years for the entire system trouble free operation.
07. Accommodation, transportation and all necessary permits, clearances and protective safety equipment for Bidder's personnel.
08. Erection/commissioning spares.
09. Consumables.

	TECHNICAL SPECIFICATION FOR IP BASED PUBLIC ADDRESS SYSTEM	SPECIFICATION NO. PE-TS-410-557-E001	
		VOLUME II B	
		SECTION - C	
	1X800 MW KOTHAGUDEM TPS	REVISION 0	DATE 19.10.2015

10. Special Tools & Tackle and test equipment.
11. Earthing as required for PA system
12. Items required to establish interface with EPABX system & Radio.
13. The items not mentioned in BOQ (ANNEXURE-3 & 4) but required for successful completion and guarantee run of the project / system including modification, addition in existing system shall be in the scope of the tenderer.

3.03.00 SCOPE OF SERVICE

Following service shall be provided by Bidder for equipment & systems supplied under this specification. However, Bidder has to provide the services required for completeness and correctness of the system irrespective of whether it is mentioned in the specification or not:-

1. Manufacture of all items as per requirement of specification, assembly etc.
2. System Engineering, development of software etc.
3. Furnishing drawings, documents, data sheets, manuals/catalogues as specified.
4. Inspection and testing at Bidder's works as per the Quality Assurance Plan.
5. Packing and forwarding of all equipment included under this specification.
6. Erection, Installation and commissioning, site testing of equipment supplied under this specification.
7. Laying & Termination of signal, power and grounding cables, providing earthing of the system and equipment as specified.
8. Establish the specified interfaces and demonstrate operation.
9. Vendor will, during the time of detail engineering and installation of the quoted system, interact and coordinate with any other agency regarding collection/retrieval of inputs/information/data and all such works shall be under the scope of this Vendor. If necessary, the Bidder shall contact the Owner before submission of their quotation.
10. Project management and scheduling including micro-planning in specific work area and reporting progress periodically.
11. Site modification and preparation of "as-built" documentation".
12. Prepare "Handing Over" protocol and hand over system to Owner.
13. Securing certification from relevant authorities, wherever applicable.

3.04.00 SCOPE OF DOCUMENTATION

01. Prepare work definition and interfacing requirements of all system components.
02. Provide system design documentation.

	TECHNICAL SPECIFICATION FOR IP BASED PUBLIC ADDRESS SYSTEM	SPECIFICATION NO. PE-TS-410-557-E001	
		VOLUME II B	
		SECTION - C	
	1X800 MW KOTHAGUDEM TPS	REVISION 0	DATE 19.10.2015

03. Provide all commissioning and test procedures.
04. Provide inspection, commissioning and test procedures for Owner's approval.
05. Operating & service manuals and handbooks.
06. Tag all equipment as per Project Specification Project Procedure.

4.00.00 PERFORMANCE GUARANTEE

- 4.00.01 The Systems/Equipment to be supplied under this specification shall meet the guaranteed performance specified in the enclosed data sheet, specification sheet and technical attachment sheet when operating at the rated/specified conditions. The acceptance of the System/Equipment shall be subject to satisfying these parameters during shop test at Bidder's works and/or at site installation in complete assembled condition.
- 4.00.02 Performance figures quoted by Bidder shall be guaranteed within the tolerance permitted by relevant standards. In case of failure of the equipment to meet the guarantee, the equipment may be liable for rejection or the decline in performance from the guaranteed performance figures will be rectified by the Bidder without any extra cost.

5.00.00 WORK SCHEDULE

- 5.00.01 Bidder shall ensure that the delivery of Equipment and accessories shall meet the project schedule. The Project schedule/Work schedule shall be furnished to Bidder during detail engineering.
- 5.00.02 Bidder shall indicate the phase-wise design, engineering, manufacturing, testing, and delivery for the complete package in the form of a bar-chart to match with the project schedule.
- 5.00.03 On finalization of the Contract, a detail supply programme for manufacture shall be furnished by Bidder for approval and will subsequently form a part of contract document.
- 5.00.04 Technical documentation such as Data Sheets, Quality Plan & Drawings are required to be submitted by bidder within the time period defined in NIT.
- 5.00.05 Modality of approval of technical documentation and priority of supply shall be mutually discussed and agreed upon with Bidder in the kick-off meeting after the placement of LOI.

6.00.00 REFERENCE DOCUMENTS CODES AND STANDARDS

- 6.00.01 The entire system and accessories materials shall conform to the requirements of the latest issues and most recent revisions and amendments of the standards listed below and to the local laws and regulations applicable to the Project.
- 6.00.02 This Specification shall be read in conjunction with material Standards, codes, practices and regulations.
- 6.00.03 Following non-exhaustive list of specific codes and standards shall apply to the all cables and accessories provided in response to this Specification. Mandatory regulations cannot be superseded by this specification.



TECHNICAL SPECIFICATION FOR
IP BASED PUBLIC ADDRESS SYSTEM

SPECIFICATION NO. PE-TS-410-557-E001

VOLUME II B

SECTION - C

1X800 MW KOTHAGUDEM TPS

REVISION 0

DATE 19.10.2015

6.00.01 **GENERAL CODES AND STANDARDS**

6.00.02 Materials shall be designed, manufactured and tested in accordance with the latest applicable Indian Standards (IS), IEC and other internationally recognized standard except where modified and/or supplemented by this specification. Performance figures quoted shall be guaranteed within the tolerance permitted by relevant standards. In case of failure of the equipment to meet the guarantee, the equipment may be liable for rejection.

6.00.03 It shall be Bidder's responsibility to comply with the requirements of all Codes and Standards which are applicable to meet the Specification.

6.00.04 The following Codes and Standards form a part of the Specification:

- ANSI : American National Standards Institute
- BS : British Standards
- CCITT : Consultative Committee on Telephone and Telegraph
- EIA : Electronics Industry Association
- FM : Factory Mutual
- IEC : International Electro technical Commission
- IEEE : Institute of Electrical and Electronic Engineering
- IS : Indian Standard
- ISA : Instrument Society of America
- ISO : International Standards Organisation
- ITU : International Telecommunication Union
- NEC : National Electrical code
- NEMA : National Electrical Manufacturers Association

AMERICAN NATIONAL STANDARDS INSTITUTE (ANSI)

- ANSI S3.5 Methods for the Calculation of the Speech Intelligibility Index

BRITISH STANDARDS (BS)

- BS EN 60268-5: 2003 Sound system equipment, Loudspeakers.
- BS EN 6840-13: 1998 Sound system equipment. Listening tests on Loudspeakers.
- BS 6840-14: 1987 Sound system equipment. Guide for circular and Elliptical Loudspeakers; outer frame diameters and mounting dimensions.
- BS 8473:2006+A1:2008 Intruder and hold-up alarm systems. Management of false alarms. Code of practice.

INDIAN STANDARD (IS)

- IS-5 Colour for ready mixed paints and enamels.
- IS-694 PVC insulated cables for working voltages up to and including 1100V.



TECHNICAL SPECIFICATION FOR
IP BASED PUBLIC ADDRESS SYSTEM

SPECIFICATION NO. PE-TS-410-557-E001

VOLUME II B

SECTION - C

1X800 MW KOTHAGUDEM TPS

REVISION 0

DATE 19.10.2015

- IS-1554 PVC insulated electric cables.
- IS-2147 Degree of protection provided by enclosures for low voltage switchgear and control gear.
- IS-3961 Recommended current ratings for cables.
- IS-3975 Mild steel wires, formed wires and tapes for armoring of cables.
- IS-5831 PVC insulation and sheath of electric cables.
- IS-7741 Specification for Loudspeakers.
- IS-8130 Conductors for insulated electric cables and flexible cords.
- IS-9302 Characteristics and methods of measurements for sound system equipment.
- IS-9537 Conduits for electrical installations.
- IS-10426 Specification for public address amplifiers.
- IS-10918 Vented type nickel cadmium batteries.

INTERNATIONAL ELECTROTECHNICAL COMMISSION (IEC)

- IEC 60268-5 Ed.3.1 en: 2007 Sound System Equipment - Part 5: Loudspeakers.
- IEC 60529 Classification of Degrees of Protection Provided by Enclosures (IP Code)
- IEC 60839-5-2 ed. 1.0 b: 1991 Alarm Systems Part 5 Requirements for alarm transmission systems.
- IEC 61000 (All Parts) Electromagnetic Compatibility (EMC)

The edition or revision of the Codes and Standards shall be the edition current at the date of the Contract.

6.02.00 **DISCREPANCIES**

6.02.01 In case of discrepancies between the technical requirements and other applicable Engineering Standards, Materials System Specifications, Standard Drawings, or industry standards, codes, and forms shall be resolved in writing by Bidder with the employer. Before starting the manufacturing/ supply, Bidder shall inform employer of any discrepancy between the instructions of the present specification and Bidder's standard.

6.02.02 It shall be the responsibility of Bidder to determine and comply with the statutory regulation (i.e. city, state, national, provincial, etc. codes or ordinances) which will apply in the location where the item is to be installed. Mandatory regulations cannot be superseded by this specification.

7.00.00 **PROJECT INFORMATION**

7.00.01 Environment specified as 'Indoor' shall be air-conditioned, where mentioned, having temperature between 20-25 degrees C and RH of about 40%. Outdoor location shall follow 'site condition' data.



TECHNICAL SPECIFICATION FOR
IP BASED PUBLIC ADDRESS SYSTEM

SPECIFICATION NO. PE-TS-410-557-E001

VOLUME II B

SECTION - C

1X800 MW KOTHAGUDEM TPS

REVISION 0

DATE 19.10.2015

7.00.02 All outdoor equipment shall be exposed to high humidity & oil/water vapour, coal dust and fly ash laden environment, vibration and electromagnetic interference generally encountered in similar industrial environment.

7.00.03 All outdoor equipments shall be mechanically or environmentally protect with sunshade or canopy wherever necessary.

8.00.00 TECHNICAL DESCRIPTION

8.01.00 GENERAL REQUIREMENTS

8.01.01 The System offered shall be minimum 2-Channel Page & Party configuration with various area-wise zone stations forming functional groups comprising Field Call Stations and Loudspeakers. The PA system shall be Paging System shall be IP based. The field call stations shall be IP addressable whereas the speakers shall be of analog type without IP addresses. The field call stations shall have additional amplifier to drive additional one speaker. The zone wise segregation shall be as under to the minimum extent.

- Unit
- Common Service
- Coal Handling Plant
- Plant Water System

8.01.02 The system shall be based on distributed network the system shall provide coverage to various locations within the plant. The distributed nodes shall be interconnected through OFC based network.

8.01.03 The system will be installed in an adverse industrial environment. Equipment in some areas will be subject to vibration, dust, oil/water vapours as prevalent in thermal generating plant.

8.01.04 The design shall be such as to provide highly intelligible minimum two-channel voice communication even in areas of high background noise (50 dB to 100 dB).

8.01.05 The system under this tender shall make use of the Optical Fiber Cable backbone, laid for connecting two geographically separated PA controllers. The PA and Industrial Talkback Controller at CCR shall cater the areas such as DM water, Boiler and Turbine, ESP, Admin Building, Security office, gates, Chemical Building, CW Plant, Switchyard etc. The PA Controller at CHP Control Room shall serve the areas around CHP such as wagon tippler, CHP Electrical Control Room. The speakers, FCS shall be connected to their respective PA controller through fiber optic cable network. The structure of the fiber optic cable backbone, field Ethernet switches, number of master call stations etc may be subject to changes during detail engineering stage. The different types of speakers and Call Stations shall be deployed over locations around each of the nodes. In noisy areas shall be used along with acoustic booth. The speakers and FCS in each zone shall be connected through Star fashion to the respective Ethernet switch.

8.01.06 Each node location and some other locations equipped with a Field Ethernet Distribution switch and shall also be equipped with PA Remote Interface equipped switching technology, which form part of the In-Plant paging and PA remote node. Ethernet switch shall be connected to the PA Speaker and Call Stations BY Cat6 cable.

8.01.07 Equipment shall be self-protecting against transients in the input A.C supply and against failure of any component or cable in the entire communication system. The In-Plant Paging system shall provide zoned and plant-wide paging together with a min 2 party



TECHNICAL SPECIFICATION FOR
IP BASED PUBLIC ADDRESS SYSTEM

SPECIFICATION NO. PE-TS-410-557-E001

VOLUME II B

SECTION - C

1X800 MW KOTHAGUDEM TPS

REVISION 0

DATE 19.10.2015

communication channels within each zone or plant area.

- 8.01.08 Required functions for individual stations shall be programmable and configurable through pre-loaded software that permits local changes to the configuration. Levels of system access and privileges shall only be assignable to selected individuals.
- 8.01.09 The PA and Industrial Talkback system shall be expandable to cater for future expansion phases in terms of additional nodes, zone expansion and additional control and access panels.
- 8.01.10 Speaker cabling and visual alert cabling shall all be on a ring to provide resilience.
- 8.01.11 Calls will be carried out through loudspeakers installed in the various locations across the Project.
- 8.01.12 The area coverage will be such that calls will be clearly audible in the paged operating areas and their surrounding space.
- 8.01.13 The plant area shall be divided into zones each with sections. Final distribution of units over the zones will be finalised during detailed design. This will be related to area configuration and other operational objectives.
- 8.01.14 Some PA and Industrial Talkback field call station units may be located in areas with a fair degree of background noise. Therefore, the requirements shall be for directional dynamic microphones, with strong noise suppression together with input/pre-amplifier sections including filtering and speech compression giving the highest practicable levels of intelligibility.
- 8.01.15 The In-Plant Paging system shall provide zoned and plant-wide paging together with a minimum of 1 Channel-party communication channels within each zone or plant area and allowing minimum one (1) simultaneous conversation within the area (zone).
- 8.01.16 The system shall be capable of providing an audio output to a Digital Voice Recording System.
- 8.01.17 Facilities shall be provided for local loudspeaker muting to prevent acoustic feedback that may be generated from nearby access panels.
- 8.01.18 Each operator's control set will be able to:
- Address a call to one or multiple sections.
 - Address a call to one or multiple zones, by activating the selected zones.
 - Transmit a general call to the whole area activating all sections simultaneously.
- 8.01.19 The system shall also provide the following facilities:
- A two wire telephone interface is to be connected to the telephone system. The PABX to which this is to be connected shall be designated during the detailed engineering phase.
 - The interface shall provide 48 V supply on the two wires respectively with 600 ohm impedance.
 - An acoustical feedback suppresser.
 - Integrated test equipment to identify faults on the external loudspeaker lines along with a Notebook PC for testing purposes at remote locations as a maintenance terminal together with the existing PC shall be utilized for testing purposes at the main equipment.



TECHNICAL SPECIFICATION FOR
IP BASED PUBLIC ADDRESS SYSTEM

SPECIFICATION NO. PE-TS-410-557-E001

VOLUME II B

SECTION - C

1X800 MW KOTHAGUDEM TPS

REVISION 0

DATE 19.10.2015

- 8.01.20 The following shall form part of the central equipment located in the CCR:
- PABX Interface
 - Acoustic feedback suppression
 - CD audio player
- 8.01.21 The operator control sets shall be provided in key location.
- 8.01.22 CD audio player shall be provided as one of the input/output sources to/from the public address system which shall have the capability to broadcast the player output.
- 8.01.23 Any field call station can selectively dial any other call station from its inbuilt dialling pad without the manual intervention of any zonal operator. The intelligence unit, dialling button/keypad etc shall be an integral part of the call station and shall not be procured from different OEMs and combined.
- 8.01.24 All the system elements in PA and Industrial Talkback system viz. Controller, field call station, speaker shall be sourced from the same OEM.
- 8.01.25 The powering philosophy for PA and Industrial Talkback system and other allied accessories shall be as under.
- Bidder to consider mini UPS suitable to provide power supply to PA system and other allied accessories. Incoming supply (240V AC 50Hz) to UPS shall be provided by the Owner within 3 meters of the point of location of the PA system and allied accessories. Power cable from owner's power supply unit to I/C of UPS and power cable required for further distribution shall be provided by the bidder.
 - All power distribution boards, MCB, power supply cable shall be provided by the Bidder.
 - Extending the power supply up to the point of installation of telecom equipment, providing power supply cable, MCB etc. shall fall under the scope of works of the Bidder.
- 8.01.26 The Bidder shall provide the earthing of the system as per their industry standard. The telecom earth shall be connected to the main Electrical earthing system by the Bidder under their scope.
- 8.01.27 **JUNCTION BOXES:**
All junction boxes (JB) shall be made of Fibreglass reinforced polyester material with minimum thickness 4 mm, door handle, self-locking with common key, door gasket shall be of synthetic rubber & provided with cage clamp type terminal blocks.
- 8.02.00 **DETAILED CHARACTERISTICS**
- 8.02.01 The equipment shall be fully solid state type, microprocessor based and programmable.
- 8.02.02 The Operator Access Units shall be microprocessor based and connected to the central control cabinet using Cat6 or suitable cable cables.
- 8.02.03 PA Controllers at CCR and CHP Control Room shall be fibre optic interfaces to establish optical communication over OFC link between two PA Controllers.
- 8.02.04 Configuration of the system shall be achieved by software for maximum flexibility. A "user friendly" setting up and checking routine shall be provided which enables an operator using a PC to implement speed commissioning and fault finding functions. The use of these methods shall allow adjustments to be easily made when the system is installed without



TECHNICAL SPECIFICATION FOR
IP BASED PUBLIC ADDRESS SYSTEM

SPECIFICATION NO. PE-TS-410-557-E001

VOLUME II B

SECTION - C

1X800 MW KOTHAGUDEM TPS

REVISION 0

DATE 19.10.2015

resulting in modifications to the system wiring. The system shall be provided with standard serial interface (preferably a USB connection) to be connected with a laptop for local and remote access for maintenance and operations activities. One Notebook PC shall be provided for these functions.

8.02.05 All software utilized shall be the latest and upgraded version.

8.02.06 The system shall be designed to comply with EMI and RFI Regulations particularly the requirements of IEC 61000 series.

8.03.00 MAIN SYSTEM FEATURES

8.03.01 Configuration of Announcement Priorities

Announcements from different sources can be configured to override others. Fixed frequency preannouncement tones can be generated under software control.

8.03.02 Gain Control of Announcements

Announcements shall be individually configurable to different levels. This is a useful feature which allows an alarm to be muted while a broadcast is made and then increased back to its original level afterwards.

8.03.03 Software

- a) The software shall be "user Friendly", for easy re-configuration, maintenance and future expansions.
- b) The software shall be able to work with the latest windows version.

8.03.04 Speaker/Line Monitoring

- a) The system shall provide the facility for monitoring speaker loop status. Automatic setting procedures shall be able to be programmed in order to check and set all output line conditions.
- b) Difference above a set percentage will result in an alarm indication on the control mimic panel.

8.03.05 Interface with EPABX System

An interface to the telephone system shall be provided to enable users to broadcast routine speech announcements from telephones assigned the correct class-of-service. The system interface to the telephone system shall be via a 2- wire/4-wire E & M tie-line/E1 line/ SIP channel. Facilities shall be included to prevent acoustic feedback that may be generated from telephones situated close to loud-speakers. Hardware required for interface with EPABX system shall be in PA system supplier's scope.

8.04.00 TECHNICAL FEATURES

8.04.01 The design of the system and distribution of loudspeakers and flashing lights shall be based on the following requirements :

- a) The alarm signal level at every location on the installation shall exceed background noise level, at that location, by at least 10dB. Greater than 20dB is undesirable.



TECHNICAL SPECIFICATION FOR
IP BASED PUBLIC ADDRESS SYSTEM

SPECIFICATION NO. PE-TS-410-557-E001

VOLUME II B

SECTION - C

1X800 MW KOTHAGUDEM TPS

REVISION 0

DATE 19.10.2015

8.04.02 The main design criteria for coverage shall be:

- a) Areas with average noise level below 86 dBA shall have complete audible voice and alarm coverage with all loudspeakers working, and complete alarm tone coverage with half the loudspeakers on.
- b) Areas with average noise level above 83 dBA shall have a partial audible voice coverage during operation. Alarm and voice signals shall be completely audible when ambient sound level is reduced below 83 dBA as during maintenance.
- c) Loudspeakers will also be installed in areas where the audible communication is impossible during normal operation due to high ambient noise level. The system in that particular area shall be designed for the situation when the particular noise is shut off.
- d) The Bidder shall be fully responsible for the design and distribution of loudspeakers across the plant including all buildings to ensure intelligible and adequate message broadcast.

8.04.03 After the completion of installation the system coverage shall be tested using SPL meter to ensure adequate coverage of the plant and its associated buildings.

8.05.00 **SYSTEM CABINET**

8.05.01 The control sub-system, speech amplifiers and their ancillary devices shall be housed in a 19" standard rack mounted system cabinet with all control, power circuits and necessary amplifiers and shall be supplied in pre-wired conditioned and shall be completely tested at manufacturer's works prior to despatch.

8.06.00 **DIGITAL VOICE STORAGE /PLAYBACK UNIT (DVSP)**

8.06.01 This unit is used, as above, to gain access to the PA system by telephone or radio, but the message to be broadcast is digitally stored and played through the DVSP monitor speaker on the Engineers Test Panel, this allows the engineer to intercept calls which he does not think are suitable for broadcast.

8.06.02 The DVSP shall record calls that cannot be sent to all required zones because some are occupied by a higher priority call. The unit shall store up to minimum 15 calls in high quality format with a maximum of three minutes for each call, including chimes and pre-recorded messages. Playback of a call can start while it is still being recorded. The unit can record and/or playback up to minimum eight calls simultaneously

8.07.00 **PROGRAMMING AND INTERFACE**

- a) The system functions may be programmed from a variety of external and/or internal sources such as via the connection to a Notebook PC.
- b) Long range remote access which may be used for setting up, fault finding, system parameter changes etc., using the PTT network via V 32 bis dial up modem is an advantage.

8.07.01 **PABX Interface**

This unit is provided in order to gain direct access to the PA system via telephones for high priority announcements by such people as supervisors, etc. The interface shall be based on industry standard open protocol. However, this interface shall be reviewed during the installation of the new IPX PABX.



TECHNICAL SPECIFICATION FOR
IP BASED PUBLIC ADDRESS SYSTEM

SPECIFICATION NO. PE-TS-410-557-E001

VOLUME II B

SECTION - C

1X800 MW KOTHAGUDEM TPS

REVISION 0

DATE 19.10.2015

8.08.00 **CONTROL SETS**

8.08.01 A directional gooseneck microphone shall form part of each control set. When the microphone shall be use, nearby loudspeakers shall be muted to avoid acoustic feedback. The microphone amplifier shall be fitted with an automatic gain control for convenience in use.

8.08.02 Each control set shall be equipped as minimum with the following:

- a) A magnet dynamic, gooseneck microphone and a telephone handset with automatic switch from the microphone to the handset upon lifting the last one.
- b) Necessary lamps, push buttons, switches, and indicators to monitor and control the system.

8.09.00 **LOUD SPEAKER**

8.09.01 **General Requirements**

- a) The loudspeakers shall be normal, weatherproof in all locations and explosion proof type, depending upon the location in which they will be installed.
- b) The nominal power is intended as the power of a sinusoidal signal continuously applicable without damage. All speakers shall have the same rated power and shall be adjusted to provide the required coverage.
- c) The primary winding of the transformer shall be tapped so that the loudspeakers will absorb from the line 100%, 50%, 20%, or 10% of its power, according to the tap used.
- d) The reproduced frequency band shall be at least 370 to 6000 Hz for all the transducers, within +/-6 dB range.

8.09.02 **Weatherproof Loudspeakers**

- a) They shall have protection to meet IP 65, IEC 60529 Publication.
- b) The explosion proof requirement shall be in accordance with the area classification in which it will be installed.
- c) The utilised material shall be polyester resin armoured with fibre glass or equivalent, suitable to resist the aggressive atmosphere. The loudspeakers shall have a diffusion angle between 100° and 120° with the minimum sound pressure level, measured 1 m away along the diffusion axis, when a continuous constant level sinusoidal sound signal with 1 W power is applied and the transformer is tapped for the maximum absorbed power shall be minimum 107 dBA.
- d) The indoor loudspeakers installed in various buildings shall provide pleasant appearance and blend with the surroundings.
- e) The flashing light shall be addressable for remote maintenance and checking from the PA Administration station.



TECHNICAL SPECIFICATION FOR
IP BASED PUBLIC ADDRESS SYSTEM

SPECIFICATION NO. PE-TS-410-557-E001

VOLUME II B

SECTION - C

1X800 MW KOTHAGUDEM TPS

REVISION 0

DATE 19.10.2015

8.09.03 **Acoustic Feedback Protection**

The system shall be fitted with devices to enable and affect frequency shifting of voice input during PABX radio access. Acoustic feedback via telephone or radio connection to the PA/alarm system can only be totally eliminated by the use of a digital voice storage/play-back (DVSP) unit.

8.09.04 **Power Supply Unit**

- a) The distribution board, 3 core, 2.5sqmm power supply cable and protection device such as MCB etc shall be provided by the Bidder.
- b) The power supply unit shall be able to supply the whole equipment load and allow 50% future growth. It shall be fitted with suitable optical indication of correct working condition.

8.10.00 **MEAN TIME TO REPAIR (MTTR)**

8.10.01 The design and construction of the PA system shall ensure high reliability and availability.

8.10.02 The PA system shall employ modular constructional techniques in its design. Allowing a first line maintenance philosophy of module replacement to be implemented.

8.10.03 The average module replacement time for the system is less than 1 hour as long as the correct spares holding are maintained as recommended by Bidder.

8.11.00 **DATASHEET-A PUBLIC ADDRESS SYSTEM**

01. System	Min.2-Channel Page & Party
02. System Architecture	Separate functional groups (Field call stations / Loudspeakers)
03. Zone Station	Area-wise
04. Master Control	One station (1) - coordinating Zone Stations.
05. Zone call discipline	Between Zones & Master station
06. Master call discipline	All Zone stations
07. Alarm siren	From MCS on Zone basis/plant basis
08. Override	From MCS for broadcast.
09. Operating Voltage	240 Volts 50 Hz AC
10. Master Control Station	Rack mounted, free standing
11. Location	Indoor, air-conditioned
12. Support capability	Expandable to 100 zone stations



TECHNICAL SPECIFICATION FOR
IP BASED PUBLIC ADDRESS SYSTEM

SPECIFICATION NO. PE-TS-410-557-E001

VOLUME II B

SECTION - C

1X800 MW KOTHAGUDEM TPS

REVISION 0

DATE 19.10.2015

13. Interface required : EPABX & Radio
14. Input sources Voice, tones, pre-recorded messages, music
15. System features Private communication, conference call, PA
16. System programming Field Programmable, touch screen
17. **Master Access Panel** Desk-top, Indoor, air-conditioned
- Microphone Gooseneck(>400mm)
 - Enclosure Anodized aluminum
 - Zone selection Dedicated buttons
 - Emergency features One touch paging, caller ID, Speed dialling
18. **Zone Station** Hands-free, wall mounted/desk top, dual direct.
- Location Indoor/Outdoor
 - Mounting Desk/Wall mounted
 - Protection Corrosion resistant & pilfer proof.
 - Protection Class IP65
 - Body Heavy duty GRP.
 - Microphone Type Gooseneck (>400mm).
 - Volume Control Via keypad.
 - Body Moulded Polyurethane
 - Operating voltage 24 V DC.
 - Distance 2Km (max.)
 - Loudspeaker Output Yes

8.12.00 **WEATHER PROOF HORN TYPE SPEAKER (15 WATT)**

01. Housing Special Plastic
02. Connection Screw Terminal
03. Ingress Protection : IP65
04. Weight Bidder to quote
05. Colour Light
06. Mounting Plastic Bracket/Stainless Bracket
07. Rated Power 15 watt
08. Transformer 100v; 25/14/7. 5/2 watt
09. Sound Pressure Level 1W, 1m 110dB



TECHNICAL SPECIFICATION FOR
IP BASED PUBLIC ADDRESS SYSTEM

SPECIFICATION NO. PE-TS-410-557-E001

VOLUME II B

SECTION - C

1X800 MW KOTHAGUDEM TPS

REVISION 0

DATE 19.10.2015

10. Sound Pressure Level 25W, 1m 120dB
11. Frequency Range 370Hz to 7000Hz
12. Dispersion-6dB- 1 KHz/4KHZ 140° I40°
13. Operating Temperature -10°C to 60°C

8.13.00 **INDOOR SPEAKER (10 WATT)**

01. Housing Special Plastic
02. Ingress Protection IP40
03. Weight Bidder to quote
04. Connection Clamp
05. Volume Control Required
06. Rated Power 6 Watt
07. Transformer 100v 6/3/. 5watt
08. Sound Pressure Level 1W, 1m 91dB
09. Effective Frequency Range 100 to 20000Hz

8.14.00 **CEILING MOUNTED SPEAKER (6 WATT)**

01. Housing Mild steel
02. Sound pressure level, power Watts/1m, dB 103 dB
03. Nett weight, Kg Bidder to quote
04. Effective frequency range, 100-15,000 Hz
05. Transformer Power tapings, Watts 0.75, 1.5, 3.0, 6.0, 10
06. Input impedance standard model, ohm13.33k, 6.6k, 3.3k, 1.66k, 1.0k
07. Impedance 8 ohm
08. Operating Temperature 0°C to +50°C
09. Protection class IP-65

8.15.00 **WEATHERPROOF OUTDOOR CALL STATION**

01. Glass fiber reinforced polyester housing
02. Plug in front unit with all functional parts
03. Dial keypad
04. Call or busy signal by light emitting diodes



TECHNICAL SPECIFICATION FOR
IP BASED PUBLIC ADDRESS SYSTEM

SPECIFICATION NO. PE-TS-410-557-E001

VOLUME II B

SECTION - C

1X800 MW KOTHAGUDEM TPS

REVISION 0

DATE 19.10.2015

05. Noise compensated inbuilt microphone with dynamic compression and PTT operation
06. Microphone sensitivity and volume control
07. Potential free relay point
08. Connector for optional amplifier booster amplifier
09. Direct intercom connections
10. Can be switched to low volume
11. Led indication of incoming call and line busy, prioritized
12. Supply voltage range : 48-60 v dc
13. Max. Quiescent current : 25 mA
14. Max. Operating current : Approx. 125 ma
15. Loud speaker : 15 w
16. Frequency range : 300 hz to 3.4 khz
17. Electrical data booster amplifier - output power : 25 w l 400 ohm
18. Operating temperature : -10° to +60° celcius
19. Protection class : IP-65
20. Area of use : Non hazardous

8.16.00 **INDOOR CALL STATION**

01. Plastic housing (ABS) with aluminum base plate
02. Gooseneck microphone (300mm)
03. Integrated full range speaker, 8 ohm
04. All keys with individual labelling area
05. Call or busy signal by light emitting diodes
06. Noise cancelling goose neck microphone with dynamic compression
07. Microphone sensitivity and loudspeaker vol control
08. Monitoring of microphone function
09. Potential free relay contact
10. Supply voltage range : 48-60 V DC
11. Frequency range : 300 Hz to 7 khz
12. Max. Quiescent current : 50 ma
13. Max. Operating current : 180 ma
14. Amplifier power rating : 1 W



TECHNICAL SPECIFICATION FOR
IP BASED PUBLIC ADDRESS SYSTEM

SPECIFICATION NO. PE-TS-410-557-E001

VOLUME II B

SECTION - C

1X800 MW KOTHAGUDEM TPS

REVISION 0

DATE 19.10.2015

15. Loudspeaker : 5Watt/8Ohm
16. Average speech power : (1 W / 1 m) 86 db
17. Electrical data booster amplifier - output power - 25 W /400 Ohm
18. Operating Temperature : 0° to +50° C
19. Protection class : IP30 or better
20. Humidity non-condensing : 90%

8.17.00 **TYPE OF INSTRUMENTS SHALL BE DESIGNATED AS BELOW:**

- a) Type-A: Handset Station complete with or without Handset and amplifier with indoor type enclosure. It shall be suitable for mounting on wall/column with in covered area inside building.
- b) Type-B: Handset Station complete with or without Handset and amplifier with outdoor type enclosure. It shall be suitable for mounting on wall/column in open area. The enclosure shall be dust proof, flame proof, water proof as per industrial standard. It shall be provided with canopy.
- c) Type-C: Desk Top Mounted Handset complete with Handset and amplifier. It shall be suitable for mounting/placing on table with in control rooms.
- d) Type-D: Outdoor type PA Instrument complete with microphone, speaker and amplifier, but without handset. The communication shall be possible thru built in microphone. The enclosure shall be dust proof, flame proof, water proof as per industrial standard. It shall be provided with canopy.
- e) Socket: Plug in type socket for communication with the help of Portable PA Inst

8.18.00 **TELEPHONE PROTECTION / ACOUSTIC HOOD**

- 1) Housing – Rot/vandal resistant glass re--enforced polyester /Hot-galvanized sheet steel or stainless steel.
- 2) Self-colour-yellow, visible during emergency/Paint- Powder Coated
- 3) Luminous yellow green glow in dark condition, lasting up to minimum 10 hours or more
- 4) Sound absorbent- Up to 12 dB(A) when it will be used as Acoustic Hood
- 5) Resistant to chemical spillage/vapours and are fire-retardant
- 6) Flashing beacons telephones and sounders can be attached to the hood
- 7) Temperature Range : +60 Deg C to -10 Deg C
- 8) Humidity : Up to 100%
- 9) Weight : 15 Kg or less
- 10) Maximum Load weight : 20 Kg
- 11) Insulation : Rockwool RAF-SE
- 12) Dimension : As per Bidder



TECHNICAL SPECIFICATION FOR
IP BASED PUBLIC ADDRESS SYSTEM

SPECIFICATION NO. PE-TS-410-557-E001

VOLUME II B

SECTION - C

1X800 MW KOTHAGUDEM TPS

REVISION 0

DATE 19.10.2015

8.19.00 UNINTERRUPTIBLE POWER SUPPLY (UPS)

UPS shall be supplied as per requirements described in relevant Indian standards. Rating and other requirement shall be as per following details

RATINGS & REQUIREMENTS

1.00.00 STATIC INVERTER

- 1.01.00 Application : UPS System for PA system
And other loads as required by Bidder.
- 1.02.00 Type : Static IGBT PWM type
- 1.03.00 Duty : Continuous
- 1.04.00 Enclosure : Sheet steel, IP42
- 1.05.00 Cooling : Natural convection or forced cooling
Using redundant fans.
- 1.06.00 Design Ambient temperature : 50 Deg.C
- 1.07.00 Inverter capacity : To be decided by the Bidder
- 1.08.00 Overload capacity : 300% for 4 m secs.
150% for 60 secs
125% for 10 mins
110% for continuous
- 1.09.00 Voltage
- a) Inverter input, Battery output : To be decided by the Bidder
- b) Nominal output : 240 V, 50 Hz, 1-phase
- 1.10.00 Voltage Regulation :
- a) Steady state (0-100% load at all input voltages and a power factors) : +/- 1.5%
- b) Transient voltage (On application or removal of 100% load) : +/- 10%
- c) Time to recover from transient : 50 milliseconds.
- 1.11.00 Wave form :
- a) Nominal frequency : 50 Hz
- b) Frequency range for all conditions of input supplies, loads & temperature occurring simultaneous or in any combination (automatically controlled) : +/- 0.05 Hz.



TECHNICAL SPECIFICATION FOR
IP BASED PUBLIC ADDRESS SYSTEM

SPECIFICATION NO. PE-TS-410-557-E001

VOLUME II B

SECTION - C

1X800 MW KOTHAGUDEM TPS

REVISION 0

DATE 19.10.2015

- c) Synchronisation limits (for maintenance of synchronism between inverter and standby A.C source) : 49 Hz to 51 Hz (factory set)
- d) Field adjustment range for (c) above : 50 +/- 0.05 Hz to 50+/- 2 Hz
- e) Total Harmonic Content : 5% maximum at rated load
- f) Harmonic content for any single harmonic : 3% maximum
- 1.12.00 Rated output current at rated output voltage with current limit not operating
- a) Current : 200%
- b) Duration : 100 milliseconds.
- 1.13.00 Efficiency at full load (Watt output/watt input) : 90% or better.
- 1.14.00 SCR derating from peak voltage and peak rating : 50%
- 2.00.00 STATIC SWITCH
- 2.01.00 Type : Solid-state, SCR
Continuous
- 2.02.00 Duty :
- 2.03.00 Enclosure : Sheet Steel, IP42
- 2.04.00 Cooling : Natural convection or forced cooling using redundant fans.
- 2.05.00 Ambient Temperature : 50 Deg.C
- 2.06.00 Capacity
- a) Continuous : Equal to full load capacity of the inverter.
- b) Overload : 300% for 4 m secs.
150% for 60 secs
125% for 10 mins
110% for continuous
- c) Peak : 1000% of continuous rating for 5 cycle.
- 2.07.00 Normal Voltage : 240V, 50 Hz, 1-phase.
- 2.08.00 Transient Voltage Tolerance : 340V peak above the nominal line voltage.
- 2.09.00 Transfer Time : less than 4 m secs.
- 3.00.00 MANUAL BY-PASS SWITCH/BREAKER
- 3.01.00 Type : Maintained, make before break.
- 3.02.00 Voltage : 600V



TECHNICAL SPECIFICATION FOR
IP BASED PUBLIC ADDRESS SYSTEM

SPECIFICATION NO. PE-TS-410-557-E001

VOLUME II B

SECTION - C

1X800 MW KOTHAGUDEM TPS

REVISION 0

DATE 19.10.2015

- 3.03.00 Rated Current : To meet the system requirement
- 4.00.00 BATTERY
- 4.01.00 Application : UPS Battery
- 4.02.00 Design Ambient Temperature : 50 Deg.C
- 4.03.00 Type : Lead Acid Plante type
- 4.04.00 Nos. of Cells per Battery : To be decided by the Bidder
- 4.05.00 Battery nominal voltage : To be decided by the Bidder
- 4.06.00 Battery AH rating : Bidder compute considering 100%
UPS load for 30 minutes followed by
60% UPS load for 30 minutes.
- 4.07.00 Method of working
- a) Float charge (Normal) : 2.23 Volts / Cell
- b) Boost charge : 2.30 Volts / Cell
(After complete discharge)
- c) End cell voltage : 1.80 Volts
- 4.08.00 Mounting : Steel Rack
- 4.09.00 Connection : Cables
- 5.00.00 BATTERY CHARGER
- 5.01.00 Charger : Float + Boost
- 5.02.00 Type : Solid-state, full wave, fully controlled.
- 5.03.00 Duty : Continuous
- 5.04.00 Enclosure : Sheet Steel, IP42
- 5.05.00 Cooling : Natural convection or forced cooling
using redundant fans.
- 5.06.00 Design Ambient Temperature : 50 Deg.C
- 5.07.00 A.C. input :
- a) Supply : 415V, 3-phase, 50 Hz
- b) Voltage variation : +/-10%
- c) Frequency variation : +3% to -5%
- d) Combined volt frequency
variation : 10% (absolute sum)
- e) Short-circuit level : 50 KA
- f) System earthing : Solidly grounded



TECHNICAL SPECIFICATION FOR
IP BASED PUBLIC ADDRESS SYSTEM

SPECIFICATION NO. PE-TS-410-557-E001

VOLUME II B

SECTION - C

1X800 MW KOTHAGUDEM TPS

REVISION 0

DATE 19.10.2015

5.08.00 D.C. output : 100% UPS load plus restoring fully discharged battery to full charge Condition in 8 hours.

5.09.00 Blocking Diode, Peak inverse voltage : 800 V (minimum)

5.10.00 Performance Requirement

a) The output voltage of the charger shall be regulated within +/- 1% of the set value for any load variation from 0 to 100% and A.C input voltage and frequency variation as indicated above in 4.06.00

b) The ripple content in charger D.C. output shall be limited to less than +/-1 with battery and less than +/-2% without battery.

6.00.00 DISTRIBUTION BOARDS

6.01.00 Type : Fixed, Modular.

6.02.00 Enclosure : Sheet Steel, IP54

6.03.00 Mounting : Free standing (can be attended from both front & back)

8.20.00 MANAGED SWITCH

Data highway shall be of high speed Ethernet and full duplex configuration. Network shall be built on the Managed Ethernet switches for better control of data traffic & performance and future expansion. Switch configuration shall be redundant with seamless changeover without any upset in the process or equipment. Failure reporting shall be available at HMI. MTBF of the switch shall be more than 20 Years. Configuration shall be automatic.

All Ethernet switches to be used in the plant shall be of same type and shall conform the specification requirements.

Other requirements shall be as follows,

a) All managed switches shall work in IEC-61850-3 protocol environment and shall support IEC-62439 standard ring redundancy topology (MRP) and also fast MRP. It shall also support IEC-62439-3 standard PRP & HSR technology with 0 ms recovery time and also support IEC-61850 switch (RSP & MSP switches)

b) Switch shall have the capacity for maximum of 4 Giga bit fiber port and 24 fast Ethernet port.

c) Switch shall act as IGMP-querier and minimum 2 alarm contacts shall be available

d) It shall have High MTBF value

e) It shall support ACA adaptor for reconfiguration of the switch in case of failure to reduce MTTR value to less than one minute and shall have minimum of 4 fibre and 4 copper din rail switch RSPL.

8.23.00 NETWORK MANAGEMENT SOFTWARE (NMS)

The minimum technical requirement of NMS is given below:

01. Automatic topology discovery and creation of network maps.



TECHNICAL SPECIFICATION FOR
IP BASED PUBLIC ADDRESS SYSTEM

SPECIFICATION NO. PE-TS-410-557-E001

VOLUME II B

SECTION - C

1X800 MW KOTHAGUDEM TPS

REVISION 0

DATE 19.10.2015

02. Should have high level Network Inventory polling capability for IP Network nodes, All available Switch , Camera, Modules , ports , Physical links , VLAN interfaces and all the other SNMP capable devices in the network
03. Should have powerful administration control
04. Detailed performance monitoring and management
05. Should have extensive fault management capabilities with Real time Event and Alarm notifications , System Logs and Audit trials
06. Scheduled Device configuration back-up and restore functionality
07. Automatic Detection of configuration changes for easy trouble shooting and Isolation
08. Should support 3rd party devices and end points
09. Should have the functionality of Group provisioning/Scheduled configuration roll out management
10. Should have the ability to perform scheduled or Unscheduled network wide software or Firmware upgrades
11. Should have the ability to customise the NMS dash boards as per the requirements
12. Should have the ability to perform/create group of devices for applying same task
13. Should have extensive centralised trouble shooting tools in built
14. Should provide the flexibility to the network administrator to assign task to an Individual network engineer and assign ownership I track the status of the issue resolution
15. The NMS solution should be preferably from the same Active switching vendor , in case vendors proposing for 3rd party NMS solution should provide all the interop reports certified by both the NMS vendor and Active switching vendor on seamless interoperability
16. All the required Hardware I Software for the NMS solution should be proposed by the bidder

8.24.00 **CAT 6 CABLE**

01. No of Pairs : 4 Pair
02. Conductor : Solid tinned copper
03. Construction Parameters : Values
04. Nominal DC Resistance : 67 ohms/1km
05. Nominal Impedance : 100 ohms/+-15 Ohms
06. Nominal Capacitance : 46pflm
07. Nominal Velocity of Propagation: 68%



TECHNICAL SPECIFICATION FOR
IP BASED PUBLIC ADDRESS SYSTEM

SPECIFICATION NO. PE-TS-410-557-E001

VOLUME II B

SECTION - C

1X800 MW KOTHAGUDEM TPS

REVISION 0

DATE 19.10.2015

08. Nominal Attention : 100 MHz:- 19.9 dB/100m
155 MHz: - 25.3 dB/100m
200 MHz: - 29.2 dB/100m
09. Insulation Materials : Poly Vinyl Chloride
10. Cable Outer Diameter : 0.38 mm+I-0.15 mm
11. Nominal Outer Diameter : 6.35 mm
12. Bend Radius : 0.90 For 6.35 mm

8.25.00 **SINGLE MODE FIBER OPTIC CABLE**

01. No. of Pairs : 6 Pair
02. Core : The fiber shall be full spectrum, low water peak type
03. Guiding standard : ITU-T recommendation G.652.D and IEC 60793-2-50
04. Bandwidth : 10Gbps
05. Core Diameter : 9 μm
06. Cladding diameter : 125 μm
07. Nominal Velocity of Propagation: 68%
08. Nominal Attention : 100 MHz: - 19.9 dB/100m
155 MHz: - 25.3 dB/100m
200 MHz: - 29.2 dB/100m
09. Optical laser source wave length: 1310nm/1550 nm
10. Attenuation level : 0.34 dB/km or better at 1310nm,
0.21dB/km or better at 1550 nm
11. Inner Sheath and Outer Sheath: Polyethylene
12. Armouring : Corrugated steel tape
13. Patch cord, Pigtails and connectors: Single mode and duplex
Type and same throughout the network
14. Bend Radius : 20X outside diameter for installed load and
10X outside diameter for long term load

8.26.00 **SPECIFICATIONS OF POWER CABLE**

SL. NO.	PARAMETER	SPECIFICATION
01.	Component Copper : Auxiliary power	Four conductors, 14AWG, 0.9mm
02.	Shielding	Unshielded



TECHNICAL SPECIFICATION FOR
IP BASED PUBLIC ADDRESS SYSTEM

SPECIFICATION NO. PE-TS-410-557-E001

VOLUME II B

SECTION - C

1X800 MW KOTHAGUDEM TPS

REVISION 0

DATE 19.10.2015

03.	Jacket	HDPE
04.	Insulation	PE
05.	Overall Copper Braiding	Overall 80% Tinned Copper Braiding

8.27.00 **ACCESSORIES**

8.27.01 **CAT6 UTP Cable**

Cat6 cable shall be Unshielded Twisted Pair (UTP- CAT6 Cable) category 6 LAN (local area network) four pair cable per box 305 mtr Blue Colour 23 AWG, which is UL listed, 3P certified and tested, conforming to the following standards in Cat 6 UTP cable like 250 MHz speed, IEC 11 801 edition 2.0, Nominal Velocity Propagation (NVP) 72%, as per EIA/TIA standards and cable laying shall be through the existing MSIPVC conduit or floor raceways including connections etc as required complete in all respects. **(Make: Legrand (LCS2)/Ortronics/ Luscent)**

8.27.02 **Information Outlet (I/O) of CAT-6 UTP**

Information outlet shall be RJ45 Tool less Information Outlet of CAT-6 UTP with white colour RJ-45 transparent shuttered socket outlets (modular) with all accessories including label holder, both side colour marking as per EIA/TIA standards. conformity of standards like ISO/IEC ed. 2, EN 50173 and EIA/TIA 568 for fast connection socket and it takes fast tool-less connectors with contact marking by double colour code 568A and B and numbers connectors with insulation displacement contact (IDC). It has the possibility of min. 5 times re- wiring in the event of error, multidirectional

cable entry. **(Make: Legrand (LCS2)/Ortronics/ Luscent).**

8.27.03 **Face Plate (Plastic Modular Face Plate white in Colour 1 Module)**

Face Plate shall be white modular plate type front plate with accessories for 1/2 nos RJ 45 data outlet, but excluding RJ45 data outlet complete in all respect with grid plate, screws, MS box etc with connections as required. **(Make: Legrand (LCS2)/Ortronics/ Luscent)**

8.27.04 **Rack End Patch Cord-1 mtr Blue in Colour**

The Patch Cord shall be of CAT6 UTP PATCH CORD - 1 MTR (3 feet) Blue Colour factory moulded as per EIA/TIA standards. **(Make: Legrand (LCS2)/Ortronics/ Luscent).**

8.27.05 **End User Site Patch Cord-2 mtr Blue in Colour**

End User Site Patch Cord shall be of CAT6 UTP LSC2 PATCH CORD - 2 MTR (7 feet) Blue Colour factory moulded as per EIA/TIA standards. **(Make: Legrand (LCS2)/Ortronics/ Luscent).**

8.27.06 **19" rack mountable 24 Port CAT6 UTP Patch Panel Loaded**

This item shall be 24 port PATCH PANEL RJ-45 Loaded CAT-6 UTP 19" rack mountable patch panel preferably with front loaded 6 in a blocks as per EIA/TIA standards, modular in mechanism. **(Make: Legrand (LCS2)/Ortronics/ Luscent).**

8.27.07 **9U cabinet 504.65X600X500 (HXWXD) - Wall Mounting Rack**

9U cabinet shall be of Width (mm)-600, Depth (mm) - 500, Approx.Net Wt (kg) - 20, CRCA 'D' Grade thickness (mm) - 1.2, Powder Colour for Cabinet - RAL9002, Glass - 4mm Toughened Tinted Glass Door, Accessories:, Cooling Fan (230V A/C 90 CFM) - 2 Nos, PDU 230VAC - 1 No, Cable Manager Metal- 2 Nos, Mounting Hardware (20 sets of M6 screws, washer, cage nuts) **(Make: Legrand (LCS2)/Ortronics/ Luscent).**



TECHNICAL SPECIFICATION FOR
IP BASED PUBLIC ADDRESS SYSTEM

SPECIFICATION NO. PE-TS-410-557-E001

VOLUME II B

SECTION - C

1X800 MW KOTHAGUDEM TPS

REVISION 0

DATE 19.10.2015

coated)) - 1 No, Wall Screws (4 sets of 2" screws, washer, rubber grommet (nickel coated)) - 1 No, Door Lock - 1 No, Front Metal Band -1 No. In the rack there must be maintained 1U = 1.75 inches space. (All Standalone rack and server should have 6A, 220V socket link with UPS line) **(Make: Legrand (LCS2)/Ortronics/Rittal).**

8.27.08 **42U cabinet LCS2 2026X800X800 (HXWXD) - Standalone Rack**

42U cabinet shall be of Width (mm) 800, Depth (mm) 800, Approx.Net Wt (kg) 150, CRCA 'D' Grade thickness (mm) 1.2, Powder Colour for Cabinet RAL 9002, Glass: 4mm Toughened Tinted Glass Door, Accessories: Cooling Fan (230V A/C 90 CFM) - 4 Nos, Cable Manager Metal- 4 Nos, PDU 230VAC - 1 No, Cable Channel 100mm wide 42U- 2 Nos, Heavy Duty Stationary Shelf 600W x 475D -1 No., Mounting Hardware (20 sets of M6 screws,washer,cage nuts (nickel coated)) - 3 Nos., Earthing Strips 150mm H - 1 No, Door Lock - 1 No, Castor Wheels (with Brake) - 2 Nos, Castor Wheels (without Brake) - 2 Nos, Front Metal Band - 1 No. In the rack there must be maintained 1U = 1.75 inches space. (All Stand alone rack and server should have 6A, 220V socket link with UPS line) **(Make: Legrand (LCS2)/Ortronics/Rittal)**

8.27.09 **Splicing Tray**

It shall be Modular Splice Tray Cassette for pigtails 12 fibre capacity. **(Make: Legrand (LCS2)/Ortronics/ Luscent).**

8.27.10 **19" LCS2 Modular Liu-Fiber Optic Drawer-24 Port**

The item shall be Modular fiber optic drawer modular 19"(LIU) 24 port - FIBER OPTIC DRAWER loaded with SC Pigtail - 9125 µm for 6 Cr. OFC armoured LCS2 and adapter for 6 OFC SM LCS2 without blanking plate. **(Make: Legrand (LCS2)/Ortronics/Luscent).**

8.27.11 **Power Cable**

The power cable shall be used for both outdoor and indoor application. It shall be 3X2.5 sq.mm size conforming to IS 1554. For outdoor application, the cable shall be armoured type. For indoor application, the power cable shall be armoured type for connection from UPS to PDB. However, it shall be unarmoured type for further cable distribution used for powering equipment like PCs, Server and network switches etc. inside rooms.

8.27.12 **HDPE Pipe**

The HDPE pipe shall be used for laying OFC and STP cables in outdoor environment. HDPE pipe shall be permanently lubricated type with ISI marked. The internal diameter of the HDPE pipe shall be suitably selected so that 50% free space is maintained during cable drawing. The pipe shall conform to DOT standard GRICDS-08I02 Nov. 2004 with latest amendments.

8.27.13 **Cable Tray**

Pre-fabricated perforated & covered cable trays of average 3 meters length and of minimum dimension 100X35X3 mm shall be used. The tray shall be of minimum 100 mm wide, fabricated from not less than 2 mm thick sheet steel and of vertical edge of height not less than 35 mm on both sides. Cable trays shall be hot dip galvanized after fabrication. Minimum value of average mass of zinc coating shall be 460 gmsq.mt. as per IS:4759. Supporting galvanized brackets shall be provided at regular intervals for fixing the trays.

8.27.14 **Power Supply Unit**

- a) The system will be powered from a suitable UPS system at 240VAC, 50Hz. A power supply unit shall provide the required low voltage levels to feed the equipment and their stand-by unit.



TECHNICAL SPECIFICATION FOR
IP BASED PUBLIC ADDRESS SYSTEM

SPECIFICATION NO. PE-TS-410-557-E001

VOLUME II B

SECTION - C

1X800 MW KOTHAGUDEM TPS

REVISION 0

DATE 19.10.2015

- b) The power supply unit shall have stabilised voltage outputs for input variation between -10% and +10%.
- c) The power supply unit shall be able to supply the whole equipment load and allow 50% future growth. It shall be fitted with suitable optical indication of correct working condition.

8.27.15 The make of all passive components except networking rack in the network including Cat6 cable, OFC cable and other accessories shall be **Legrand (LCS2) /Ortronics / Luscent**. The approved make of networking rack shall be of **Legrand (LCS2) /IBM / Libert / Rittal**

8.28.00 **UNINTERRUPTIBLE POWER SUPPLY (UPS)**

UPS shall be supplied as per requirements described in clause no 8.19.00

9.00.00 **ERECTION & COMMISSIONING**

Bidder's scope of work shall include the erection and commissioning of the entire system offered. Bidder shall include all erection materials, consumables etc for the purpose. Bidder shall arrange all erection tools, tackle and calibration instruments.

9.01.01 **INCLUSION IN ERECTION SUPPLY & WORKS**

9.01.02 Supply of erection hardware with all accessories as specified herein.

- a) Erection of equipment with all erection material & accessories
- b) Cabling works as specified.
- c) Pre-commissioning activity, loop checking, calibration & testing
- d) Provide supervision of all above activities.
- e) Supply of consumables
- f) Supply of erection/commissioning spares.
- g) Providing all necessary Tools & Tackle
- h) Painting with anticorrosive paint wherever required.
- i) Commissioning.

9.02.00 **SCOPE OF ERECTION SERVICE**

1. Keep calibration records.
2. Maintaining proper documentation & handing over to Owner.
3. Create defect records and insurance claim documentation.

9.03.00 **TECHNICAL SPECIFICATION OF ERECTION HARDWARE**

- a) This section provides the general technical requirements for the erection hardware to be supplied under this package.



TECHNICAL SPECIFICATION FOR
IP BASED PUBLIC ADDRESS SYSTEM

SPECIFICATION NO. PE-TS-410-557-E001

VOLUME II B

SECTION - C

1X800 MW KOTHAGUDEM TPS

REVISION 0

DATE 19.10.2015

- b) All erection materials shall be of good quality and conform to the operating environment of the plant.

9.03.01 **Rigid Steel Conduit**

This shall meet the technical requirements as described in applicable Indian standards and shall meet the statutory requirement.

9.03.02 **Flexible Conduit**

This shall meet the technical requirements as described in applicable Indian standards and shall meet the statutory requirement.

9.03.03 **Special Fittings**

This shall meet the technical requirements as described in applicable Indian standards and shall meet the statutory requirement.

9.03.04 **Distribution Frames & Junction Boxes**

This shall meet the technical requirements as described in applicable Indian standards and shall meet the statutory requirement.

9.03.05 **Cable Glands**

This shall meet the technical requirements as described in applicable Indian standards and shall meet the statutory requirement.

9.03.06 **Earthing Wire**

This shall meet the technical requirements as described in applicable Indian standards and shall meet the statutory requirement.

9.04.00 **GENERAL GUIDELINES & PRACTICE FOR ERECTION**

Erection procedure shall follow sound engineering practice throughout and shall not cause hindrance to the activities of other Bidders at the work site. The sequence of work activities shall follow logical sequence and shall be based on work-front availability.

9.04.01 **Panels & Cubicles**

This shall meet the technical requirements as described in applicable Indian standards and shall meet the statutory requirement.

9.04.02 **Cabling Works (Overground)**

This shall meet the technical requirements as described in applicable Indian standards and shall meet the statutory requirement.

9.04.03 **Conduiting Works**

This shall meet the technical requirements as described in applicable Indian standards and shall meet the statutory requirement.

9.04.04 **Cabling Works (Underground)**



TECHNICAL SPECIFICATION FOR
IP BASED PUBLIC ADDRESS SYSTEM

SPECIFICATION NO. PE-TS-410-557-E001

VOLUME II B

SECTION - C

1X800 MW KOTHAGUDEM TPS

REVISION 0

DATE 19.10.2015

This shall meet the technical requirements as described in applicable Indian standards and shall meet the statutory requirement.

9.04.05 **Earthing**

This shall meet the technical requirements as described in applicable Indian standards and shall meet the statutory requirement.

10.00.00 DOCUMENTATION

10.00.01 Details of documentation to be supplied as part of the System shall be submitted to Owner for approval prior to execution of the contract.

10.00.02 Each documentation deliverable shall be an integral part of Bidder's Project schedule and shall be identified by date for delivery.

10.00.03 All documentation shall be in the English language.

10.00.04 The following data shall be shown on all documents and/or drawings :

- Name of Bidder / Bidder
- Correct and complete designation of the document
- Exact indication of the scale employed
- Revision Index and type of revision
- Name of the site.

10.00.05 Bidder shall supply final approved sets of documentation in hard copy and soft copies on DVD.

10.00.06 Bidder shall provide the signature and seal on the each and every pages of this specification along with their offer for the confirmation to all the clauses. Along with submit deviation/clarification list if any in given format.

10.00.07 Final Documentation shall be assembled as per Owner's instructions for collation of Dossiers.

10.00.08 Following sections detail the minimum set of documentation that shall be supplied with the System.

10.01.00 ENGINEERING DESIGN DOCUMENTATION

10.01.01 Bidder will produce drawings of complete system to be submitted to Owner for approval, indicating upon each the following :

- Overall dimensional drawing of system cabinet, console and its accessories.
- Block diagram of system offered with a brief write-up on operation including hook-up arrangement with existing system.
- Data sheets.
- Bill of Materials.
- Typical general arrangement drawings of various handset and speaker stations.
- Schematic diagram of each type of station.
- Mounting details.



TECHNICAL SPECIFICATION FOR
IP BASED PUBLIC ADDRESS SYSTEM

SPECIFICATION NO. PE-TS-410-557-E001

VOLUME II B

SECTION - C

1X800 MW KOTHAGUDEM TPS

REVISION 0

DATE 19.10.2015

- Cable connection diagram for various type of stations, clearly indicating cable size, number of pairs/cores etc.
- Total power consumption details.
- Heat load details of panel equipments.
- Technical leaflets on each piece of equipment viz handset, speaker etc.

10.01.02 The Systems Design Manual shall contain all relevant information pertaining to the design and operation of the delivered equipment.

10.01.03 This is intended to provide Owner with an understanding of the operational and design parameters of the equipment and to resolve System operational problems.

10.01.04 This documentation shall typically include the following items, presented in a Systems Design Manual:

- Equipment design calculations and selection basis.
- Equipment construction and assembly drawings.
- Parts list and drawings with manufacturer's identification codes.
- Systems connection diagrams.
- Accessories list and drawings with manufacturer's identification codes.

10.02.00 **OPERATION & MAINTENANCE DRAWINGS AND DOCUMENTATION**

10.02.01 The O&M Drawings and Documentation shall typically include the following items:

- Assembly drawings.
- Parts list and drawings with manufacturer's identification codes.
- Accessories list and drawings with manufacturer's identification codes.
- O&M schedules.
- Maintenance guidelines including lapping instructions.
- Troubleshooting guides.

10.02.02 The O&M manuals shall be submitted in the form of handy, hard bound books which can be easily handled and transported to site.

10.03.00 **DRAWING/ DOCUMENT SUBMISSION REQUIREMENTS**

10.03.01 Bid shall contain at least the following documents:

SL. NO.	DOCUMENT TYPE
01.	Supply Document list
02.	Supply program
03.	Data sheets
04.	Technical specifications and relevant drawings



TECHNICAL SPECIFICATION FOR
IP BASED PUBLIC ADDRESS SYSTEM

SPECIFICATION NO. PE-TS-410-557-E001

VOLUME II B

SECTION - C

1X800 MW KOTHAGUDEM TPS

REVISION 0

DATE 19.10.2015

05.	Start-up, Mandatory and Recommended spare parts
06.	List of Tools and Tackle
07.	Proposed System schematic diagram.
08.	Write up on architecture and operation of proposed system
09.	BILL OF MATERIALS with make and model no. of equipment
10.	Power requirement. (capacity of FCBC and SMF battery)
11.	Quality Control Plan

10.03.02 Following documents shall be submitted after award of contract:

SL. NO.	DOCUMENT TYPE
01.	Supply Document List
02.	Supply Program
03.	Data Sheets
04.	System Architecture Drawing
05.	Constructive equipment drawings (PA Controller, Call Station and accessories dimensional dwgs)
06.	Technical Specifications (catalogues, assembly and erection specifications)
	Details of Panel and Installation
	Erection/Installation Drawing
	Equipment Layout Drawing in buildings I locations
	Wiring Diagram of Panel
	Cable Route Layout Drawing
	Power Distribution Scheme Diagram
	Cable schedule
07.	Test certificates
08.	Compliance certificates
09.	Quality Control Plan
10.	Test procedures
11.	Start-up , Recommended and mandatory spare parts List
12.	Tools and tackle & consumable list
13.	Operation and maintenance manuals
14.	Final version of all drawings and documents furnished with the Bid.



TECHNICAL SPECIFICATION FOR
IP BASED PUBLIC ADDRESS SYSTEM

SPECIFICATION NO. PE-TS-410-557-E001

VOLUME II B

SECTION - C

1X800 MW KOTHAGUDEM TPS

REVISION 0

DATE 19.10.2015

10.04.00 **AS-BUILT DRAWINGS**

Upon completion of the final acceptance of the System by Owner, all construction drawings shall be updated by Bidder to an as-built status to reflect the equipment and System configurations as actually installed.

11.00.00 **TESTING**

11.01.00 **FACTORY ACCEPTANCE TEST (FAT)**

11.01.01 Factory Acceptance Test procedure shall be prepared by Bidder along with Quality Assurance Plan. The document shall be subject to Owner's approval.

11.01.02 All System equipment shall be tested in the factory prior to clearance for shipping. The FAT shall include individual equipment tests under fully assembled condition.

11.01.03 The FAT shall demonstrate adherence that the equipment meets the design standards and functional compliance.

11.01.04 One (1) month prior to the FAT, Bidder shall submit a test procedure to Owner for approval. . Duration of FAT at manufacturer's works shall be at least two weeks.

11.01.05 Owner's representative may, at Owner's sole discretion, attend the FAT. In this event, Bidder shall ensure all tests are carried out in the presence of Owner's personnel. If Owner declines to attend the FAT, Bidder shall carry out these tests and submit the results to Owner for review.

11.01.06 Factory Acceptance Tests (FATs) shall be documented with the results obtained and the success or failure of the test. The test results shall be submitted to Owner prior to clearance of the FAT and authority by Owner is given to ship.

11.02.00 **COMMISSIONING**

11.02.01 Bidder is responsible for delivering a fully functional equipment that meets all the requirements of the Specification and applicable standards.

11.02.02 The Commissioning processes will demonstrate the above to Owner, before handing over of the System.

11.02.03 System Commissioning shall comprise of a number of different activities culminating in the acceptance of the operational System by Owner. These activities are detailed in the following sections.

11.02.04 Bidder shall provide all necessary test equipment required to carry out the Commissioning and acceptance testing.

11.03.00 **SITE ACCEPTANCE TEST (SAT)**

11.03.01 Site acceptance test shall be performed by Bidder to verify the full operational functionality of the System.

11.03.02 Four weeks prior to the SAT Bidder shall submit a test procedure to Owner for approval.



TECHNICAL SPECIFICATION FOR
IP BASED PUBLIC ADDRESS SYSTEM

SPECIFICATION NO. PE-TS-410-557-E001

VOLUME II B

SECTION - C

1X800 MW KOTHAGUDEM TPS

REVISION 0

DATE 19.10.2015

11.03.03 All SAT tests shall be documented with the results obtained and their success or failure. These test results shall be submitted to Owner prior to clearance of the SAT and proceeding to the final performance tests.

12.00.00 MAINTENANCE REQUIREMENTS

12.01.00 MAINTENANCE PHILOSOPHY

12.01.01 Owner's maintenance philosophy is to undertake first line field repair by modular replacement. The module shall then be returned to the supplier, who shall either repair it or replace it during the warranty period.

12.01.02 The warranty period shall be a period a twelve (12) months, beginning when commissioning is reached.

13.00.00 SPARES, TOOLS, AND TEST EQUIPMENT

13.01.00 SPARES

13.01.01 Recommended Spares

- a) Supply of spare parts as necessary and recommended by Bidder for three (3) years of reliable, trouble-free operation and maintenance of the items supplied under this specification.
- b) List of such spares shall be supplied.
- c) Bidder shall also assume the responsibility of supplying all required spare parts that the plant may need for Equipment supplied under t h i s specification for ten (10) years from the date of contract.

13.01.02 Mandatory (Contractual) Spares

Mandatory spare shall be supplied as per requirements described in annexure-3G

13.01.03 Start-Up and Commissioning Spares

- a) Spares which may be required during tests, trial, commissioning and during guarantee run shall be arranged separately.
- b) Spares which will be used for this purpose shall be replaced by the Bidder within reasonable period of time.
- c) The cost of such spares shall be quoted separately. This may be ordered in part or on the whole.

13.02.00 GENERAL REQUIREMENTS OF SPARES

13.02.01 All spares required for operation/maintenance by the Owner shall be delivered in unused new condition.

13.02.02 Spares shall be interchangeable with the parts for which they are intended for replacement.

13.02.03 Bidder shall indicate the service expectancy period for equipment / parts under normal operating conditions after which replacement will be necessary.

13.02.04 Spares shall be properly packed for long term storage under the prevailing site condition and shall be clearly labelled for easy identification without uncarting. Any



TECHNICAL SPECIFICATION FOR
IP BASED PUBLIC ADDRESS SYSTEM

SPECIFICATION NO. PE-TS-410-557-E001

VOLUME II B

SECTION - C

1X800 MW KOTHAGUDEM TPS

REVISION 0

DATE 19.10.2015

spare item having limited shelf life shall be clearly labelled for the expiry date beyond which it cannot be used.

- 13.02.05 Bidder shall inform the Owner, after having carried out the supply, if a component or part of an equipment will not be produced regularly any longer, specifying the new component or the material type which can be utilised in substitution.
- 13.02.06 Bidder's commitment in that case will be extended for a period of time which will not be lower than 10 years.
- 13.02.07 Any spare parts for the system used during the Warranty Period shall be replenished at the Bidder's expense.
- 13.02.08 Bidder shall provide ordering information to order consumable and spare parts as required. Information required is:
- Description of item
 - Bidder 's reference number
 - Standard quantities recommended for start-up and normal operation
 - Spare Parts Interchangeability Records (SPIR) procedures.

13.03.00 TOOLS & TACKLE

- 13.03.01 Bidder, in his proposal, shall indicate a list of all tools and tackle which may be required for erection, maintenance, overhaul and replacement of equipment / component to be supplied under this specification.
- 13.03.02 List of such items shall be supplied in the form of the enclosed format along with unit price.
- 13.03.03 Order for such tools & tackle may be placed simultaneously or otherwise at the option of Owner.
- 13.03.04 The cost of tools and tackle shall be quoted separately. Tools and tackle may be ordered in part or on the whole.

14.00.00 CLEANING, PROTECTION AND PAINTING

- 14.00.01 All equipment shall be shipped in properly cleaned condition. All the equipment shall be thoroughly cleaned to remove mill scales, rust etc. and properly painted with anti-rust primer, where applicable
- 14.00.02 Some of the equipment and accessories, after arrival at site, are likely to be in storage for long periods before they are taken up for erection. Bidder may provide adequate protection for preventing damage due to corrosion, dust I dirt ingress, ageing etc.
- 14.00.03 Plugs shall be provided at cable entry holes/adapters to avoid entry of dust and foreign particles. Paper cap will not be acceptable.

15.00.00 IDENTIFICATION, MARKING, PACKING AND STORING

- 15.00.01 Each equipment shall be individually packed, tagged and protected.
- 15.00.02 Inscription on equipment (labels) shall be in English.



TECHNICAL SPECIFICATION FOR
IP BASED PUBLIC ADDRESS SYSTEM

SPECIFICATION NO. PE-TS-410-557-E001

VOLUME II B

SECTION - C

1X800 MW KOTHAGUDEM TPS

REVISION 0

DATE 19.10.2015

15.00.03 Packing must be such to protect all goods from possible impacts and foreign matters; moreover, it must limit the influence of both the climate and the environment, and be suitable for the kind of shipping provided for.

15.00.04 In packing the equipment and accessories, all necessary precautions will have to be taken to avoid any damage during transport and delivery.

15.00.05 All items supplied shall be packed for long term storage under the climatic conditions prevailing at the site. Small items shall be packed in sealed transparent plastic bags with desiccator packs as necessary. Each item shall be clearly marked with its description, purpose and plant designation code as applicable. When more than one item is packed in a single case a general description of the contents is to be shown on the outside of each case and a detailed list enclosed. All cases and other packages must be suitably marked and numbered for identification purposes.

16.00.00 SHIPMENT

16.00.01 Bidder shall be responsible for ensuring that all equipment are carefully and/or suitably packed for shipment, so that they arrive at site in good condition and remain so during storage at site. Before despatch, all exposed surface shall be protected by applying anti rust primer (two coats) and suitable cover shall be provided for the equipment to be supplied.

16.00.02 Bidder will be responsible for all damages due to improper preparation of the goods for shipment

17.00.00 QUALITY ASSURANCE PLAN

17.00.01 Equipment supplied under this specification shall have assured quality and workmanship.

17.00.02 Bidder shall complete the Quality Control Plan with the information pertaining to him, in particular with the reference of the documents to be used.

17.00.03 The QCP completed by Bidder shall be submitted to employer for approval. The QAP matrix furnished hereunder is for guidance only.

17.00.04 Bidder shall carry out all the checks, tests and inspections required to verify the compliance of the supply with the specification requirements at his own expenses. Applicable test will be as per the *Inspection and Test Plan*.

17.00.05 If not specified otherwise in Contract, Bidder shall notify Owner, 10 (ten) complete working days in advance, that the equipment is ready for inspection. This notification shall include the following information :

- Bidder's Name/ address/ telephone and fax numbers
- Job /Subject, Purchase order number;
- Type / Serial No. / Tag No. / Model No.;
- List of parts to be tested;
- Type of inspection/test.....phase no.....of QCP
no.....rev.....;
- Owner attendance;
- Place and date of the inspection;
- Quantity of available items;
- Expected duration;



TECHNICAL SPECIFICATION FOR
IP BASED PUBLIC ADDRESS SYSTEM

SPECIFICATION NO. PE-TS-410-557-E001

VOLUME II B

SECTION - C

1X800 MW KOTHAGUDEM TPS

REVISION 0

DATE 19.10.2015

- Bidder's reference person (name, phone, fax)

In case the inspection is performed without due notification, repetition of those tests may be requested at Bidder's expenses.

17.00.06 Owner and/or testing body's inspector shall have free access to Bidder's works both during manufacturing and tests & trials.

17.00.07 Bidder shall stand guarantee for perfect operation of the equipment during the period specified in the warranty.

17.00.08 Regardless of the results of the tests performed in Bidder's works, the final test will be performed at the plant, under actual operating conditions.

Bidder shall therefore undertake to replace, free of charge and within shortest time possible, all material which, in operating conditions, shall fail to comply with contractual requirements.

17.00.09 Bidder shall arrange the inspection and tests in easily accessible location and in properly illuminated shop to carry out the inspection in proper way.

Bidder shall, if called for, produce the necessary technical documents (drawings, specifications etc.) and copies of the codes or procedures applied to the execution of inspections and/or tests.

Owner reserves the right to reject the inspections and tests which fail to fulfil the above conditions.

17.00.10 Bidder shall perform inspections and tests in full compliance with industrial safety rules, to safeguard his own personnel as well as Owner's/ Consultant's Inspectors.

17.00.11 Bidder shall be responsible for the performance of the tests and shall :

- a) provide qualified and specially skilled personnel
- b) provide calibrated instruments with relevant certification

17.00.12 For Type or Special tests, Bidder shall indicate the location for carrying out the tests (Bidder's works or any recognized laboratory).

In case Owner is expected to give approval on the basis of certifications concerning similar previous supplies, Bidder shall submit for approval to Owner the documentation demonstrating the compliance between the supply and the certified model.

17.00.13 If during the execution or at the end of the supply, any non-conformances are noted, Bidder shall implement and adequately document all the corrective actions necessary to restore the contractually required conditions. The documentation related to the corrective actions shall be included in the final certification report. If the non-conformance compromises the functional or safety feature of the equipment or specific interface elements, the supplier shall inform employer in advance in writing on the corrective actions he intend to implement. Employer has the right to reject (totally or partially) the proposed actions if considered inadequate or insufficient and Bidder may be asked for more adequate actions. The failure to communicate such non-conformances will be considered fraudulent intention.

17.00.14 During manufacture Bidder shall make available, the certificates concerning the inspections and tests performed. At the end, Bidder shall provide the certificates required for components for which a QCP has been developed. These certificates shall be kept in dossiers and shall comprise the documents concerning



TECHNICAL SPECIFICATION FOR
IP BASED PUBLIC ADDRESS SYSTEM

SPECIFICATION NO. PE-TS-410-557-E001

VOLUME II B

SECTION - C

1X800 MW KOTHAGUDEM TPS

REVISION 0

DATE 19.10.2015

manufacturing, inspections and tests performed on the component and on its parts. The dossier shall be organised as follows:

- Cover sheet containing:
- Bidder's Name;
- Job and order number;
- Identification (model no. & serial no.) and short description of the supplied component;
- Date and Bidder 's signature;
- List of content;
- QCP ;
- Certificates of materials, inspections and tests listed in the QCP;
- Non-conformance report (if any);
- Final Inspection Report.

All the pages shall be numbered.

17.00.15 The supply shall be considered completed if :

- the documents presented to Owner have been approved;
- the materials are in compliance with the specification; and related certificates are available and acceptable;
- the necessary qualification certificates are available and acceptable;
- the components have been inspected, examined and tested as required and related certificates are available and acceptable;
- the non-conformances have been documented and accepted by Owner;
- the components are clean, protected and identified;
- the necessary instructions for protection, handling or storage are available;
- the Final Inspection Report has been submitted.

17.00.16 Bidder shall prepare a QCP for each component or group of similar components.

- Bidder must indicate his identifying data and those concerning the order and the component for which the QCP is referred to;
- Bidder shall indicate the materials, parts and processes to be inspected, checked and tested and related tests and inspections to be executed.

Other types of forms may be accepted only if they contain the same information of Bidder.

17.00.17 The QCP prepared by Bidder shall be submitted to Owner for approval at least 15 days before the start of the related activities. Bidder shall be authorised to proceed if the QCP has been approved.

17.00.18 General requirements for inspection shall be as per the following guidelines.

- a) *Non Destructive Tests* (NOT APPLICABLE)
- b) *Tests*

	TECHNICAL SPECIFICATION FOR IP BASED PUBLIC ADDRESS SYSTEM	SPECIFICATION NO. PE-TS-410-557-E001	
		VOLUME II B	
		SECTION - C	
	1X800 MW KOTHAGUDEM TPS	REVISION 0	DATE 19.10.2015

- The materials, manufacturing and finished components shall be inspected, controlled and tested as defined in this paragraph in compliance with standard codes and technical specification that shall be subject Owner's approval.

c) *Visual Inspections*

The PA Controller and speakers, call stations etc. shall be subjected to the following visual inspections and checking:

- Check of the supply (quantities, accessories, markings dimensions/ examinations in compliance with relevant drawings);

1X800 MW KOTHAGUDEM TPS-BOQ OF PA SYSTEM

ZONE WISE DISTRIBUTION OF HANDSET STATIONS-ANNEXURE-1

S.NO	DESCRIPTION OF LOCATION	MCS	FCS TYPE_A	FCS TYPE_B	FCS TYPE_C	FCS TYPE_D	FALSE CEILING TYPE SPEAKER	CONE TYPE SPEAKER	HORNE TYPE SPEAKER	EXTENSION AMPLIFIER	ACOUSTIC BOOTH/HOOD	REMARKS
A. ZONE-1 (Unit-1 Area)												
1	Power House Building Unit#1 (Location of each duringn detailed engg.)	1	8	4	4		4	8	4		4	
2	Boiler Area Unit#1 (Location of each duringn detailed engg)			16					16		8	
3	ESP Area Unit#1		1						2	1		
4	Mill Bay Area , Unit # 1			2					2			
5	FD/PA/ID FAN AREA Unit # 1		1	1				1	1		1	
6	AHP UNIT-1		2	2				2	2			
Total for One Unit		1	12	25	4		4	11	27	1	13	
B. ZONE-2 (Common services Area)												
1	Power House Building Control Room	1			1		1	1		1		
2	Switchyard Area			6	1				10	3		
3	Fuel Oil Pump House					1EX			1			
4	Lubricating Oil Tank					1EX			1			
5	Central Control Building (Overall Master Control Station)	1	2				1		2			
6	For LAB		1				1					
7	Air Conditioning Plant			1					1			
8	Emergency DG Building			1	1			1	1		1	
9	Ash slurry pump house		1						1			
10	Ash Water Pump House		2		1		1	2				
11	Silo Utility Building		2		1		1	2				
12	Chemical House		2		1		1	2				
13	Service Building		5		1		1	5				
14	Fire Engine House		1	1	1		1	1	1			
15	Air Comp. House Area			1					1		1	
16	Hydrogen generation Building					1EX		1				
17	Administration Building		5		2		2	5				
18	Canteen		2					2				
19	Security & Time Office		2		1		1		2			
20	Workshop Building			1					1			
21	AHP Compressor Building			1					1			
22	Parking Area			2					2			
23	Ash Slurry Pump House		2					2				
24	Watch Tower			6					6			
25	Security Post			1					1			
26	Weigh Bridge					1			1			
TOTAL ZONE-2		2	27	21	11	1,3EX	11	24	33	4	2	
C. ZONE-3 (CHP Area)												
1	CHP Areas	1		13					12			
2	Coal Bulldozer House			1					2		1	

3	Coal complex office building		1		1		1	2			
4	Wagon Tippler Control Room			2	1		1	1	2		
5	Coal transfer tower			2					2		
6	Crusher house			2					2	2	
7	Track Hopper complex			1							
	TOTAL ZONE-3	1	1	21	2		2	3	20	0	3

D.	ZONE-4 (Plant Water)										
1	Cooling Water Treatment Plant			2					2		2
2	Raw Water Reservoir Area			2					2		2
3	Raw Water Pump House			2	1		1		2		2
4	Effluent Treatment Plant			2	1		1		2		2
5	Clarified Water Pump House			2	1		1		2		2
6	Sewage Treatment Plant			2	1		1		2		
7	Water Service S/S & DM Plant Area	1		2	1		1		2		2
8	CW \$ ACW Pump House Area			2	2			2	2		1
	Total zone-4	1	0	16	7	0	5	2	16	0	13
	Spare	1	4	3	2	1 EX	2	2	4	2	2
	Grand Total	6	44	86	26	1,4EX	24	42	100	7	33
	Total Considered for project	7	44	86	26	5	24	42	112	7	34

1	ACOUSTIC BOOTH IN	QUANTIT Y OF BOOTH FOR ONE UNIT	QUANTITY FOR FOUR UNIT	TOTAL ACOUSTI C BOOTH	TOTAL ACOUSTI C HOOD
	BFP AREA	1		16	18
	ID FAN AREA	1			
	FD FAN AREA	1			
	PA FAN AREA	1			
	MILLS AREA	2			
	BOILER BURNER FLOOR	1			
	TG 0.0M	1			
	TG 8.5M	1			
	TG 17 M	1			
	FEEDER FLOOR	1			
	AHP SILO	1			
	CRUSHER HOUSE	2			
	AIR COMPRESSOR	1			
	DG BUILDING	1			

ANNEXURE-2

Sheet 2 of 2

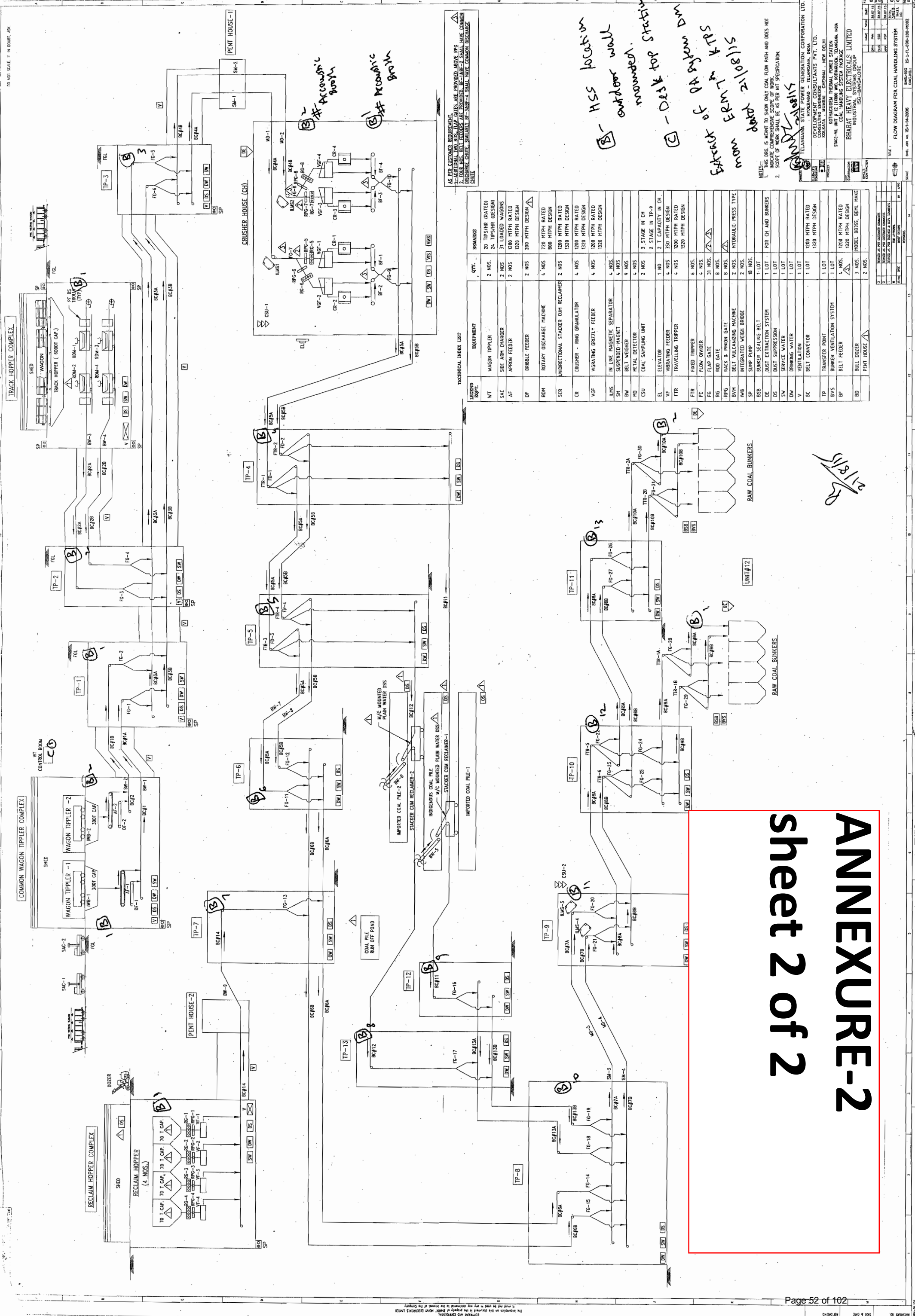

AS PER CUSTOMER REQUIREMENT, 1. FOUR NOS. BELL FEEDERS ARE PROVIDED. 2. FOUR NOS. BELL FEEDERS ARE PROVIDED. 3. SMALL HATCH COMMON DISCHARGE CHUTE. 4. SMALL HATCH COMMON DISCHARGE CHUTE.

LEGEND	EQUIPMENT	QTY.	REMARKS
WT	WAGON TIPPLER	2 NOS.	20 TPS/HR (RATED)
SAC	SIDE ARM CHARGER	2 NOS.	24 TPS/HR (DESIGN)
AF	APRON FEEDER	2 NOS.	31 LOADED WAGONS
DF	DRIBBLE FEEDER	2 NOS.	1200 MTPH RATED
ROM	ROTARY DISCHARGE MACHINE	4 NOS.	200 MTPH DESIGN
SCR	UNIDIRECTIONAL STACKER CUM RECLAIMER	2 NOS.	120 MTPH RATED
CR	CRUSHER - RING GRANULATOR	4 NOS.	1200 MTPH RATED
VGF	VIBRATING GRZLY FEEDER	4 NOS.	1200 MTPH RATED
LMS	IN LINE MAGNETIC SEPARATOR	4 NOS.	1200 MTPH RATED
SM	SUSPENDED MAGNET	4 NOS.	800 MTPH DESIGN
BW	BELT WEIGHER	9 NOS.	1200 MTPH RATED
MD	METAL DETECTOR	4 NOS.	1200 MTPH DESIGN
CSU	COAL SAMPLING UNIT	2 NOS.	3 STAGE IN CH
EL	ELEVATOR	1 NO.	2 T CAPACITY IN CH
VF	VIBRATING FEEDER	4 NOS.	350 MTPH DESIGN
TTR	TRAVELLING TRIPPER	4 NOS.	1200 MTPH DESIGN
FT	FIXED TRIPPER	6 NOS.	1200 MTPH DESIGN
FD	FLOW DIVIDER	4 NOS.	1200 MTPH DESIGN
FG	FLAP GATE	31 NOS.	1200 MTPH DESIGN
RG	RACK GATE	8 NOS.	1200 MTPH DESIGN
RF	RACK & PINION GATE	8 NOS.	1200 MTPH DESIGN
BVH	BELT VULCANIZING MACHINE	2 NOS.	HYDRAULIC PRESS TYPE
IMB	INTEGRATED WEIGH BRIDGE	2 NOS.	1200 MTPH DESIGN
SP	SUMP PUMP	2 NOS.	1200 MTPH DESIGN
DS	DUST SEALING BELT	1 LOT	FOR CH AND BUNKERS
DE	DUST EXTRACTION SYSTEM	1 LOT	FOR CH AND BUNKERS
SW	SERVE WATER	1 LOT	1200 MTPH RATED
DW	DRINKING WATER	1 LOT	1200 MTPH DESIGN
V	VENTILATION	1 LOT	1200 MTPH DESIGN
BC	BELT CONVEYOR	1 LOT	1200 MTPH RATED
TP	TRANSFER POINT	1 LOT	1200 MTPH DESIGN
BVS	BUNKER VENTILATION SYSTEM	1 LOT	1200 MTPH RATED
BF	BELT FEEDER	4 NOS.	1200 MTPH DESIGN
BD	BULL DOZER	3 NOS.	MODEL BOSS, BEAL MAKE
PH	PENT HOUSE	2 NOS.	1200 MTPH DESIGN

Handwritten notes:
 1. HSS location outdoor wall mounted.
 2. - D200 x 4 for 3000 STEEL RAIL.
 3. SILLING 12/18/15.
 4. STAIRS 4 STAIRS.
 5. 04 SYSTEM DM.
 6. 12/18/15.

NOTES:
 1. THIS DRC IS MEANT TO SHOW ONLY COAL FLOW PATH AND DOES NOT INDICATE COMPREHENSIVE SCOPE OF WORK.
 2. SCOPE OF WORK SHALL BE AS PER MTS SPECIFICATION.

TELANGANA STATE POWER GENERATION CORPORATION LTD.
 DEVELOPMENT CONSULTANTS PVT. LTD.
 HYDRABAD - TELANGANA, INDIA.
 PROJECT:
 KOTHAGUDEM THERMAL POWER STATION
 STEEL COAL HANDLING SYSTEM PACKAGE
 BHARAT HEAVY ELECTRICALS LIMITED
 INDUSTRIAL SYSTEMS GROUP
 BANGALORE

SCALE: 1:1000

DATE: 15-11-2006

PROJECT NO: 15-11-2006

DESIGN NO: 15-11-2006

FLOW DIAGRAM FOR COAL HANDLING SYSTEM

1X 800 MW KOTHAGUDEM TPS						
BOQ CUM PRICE SCHEDULE FOR PA SYSTEM ANNEXURE-3						
Sl. No.	Item Name	MAKE/ MODEL	UOM	Quantity	Unit Rate (Rs.) (Ex. Works)	Total Rate (Rs.) (Ex. Works)
(A)	MAIN ITEMS					
1	IP BASED PA CONTROLLER		NOS	2		
2	MASTER CONTROL STATION (MCS) WITH EXTENSION AMPLIFIER		NOS	7		
3	FIELD CALL STATION (FCS) TYPE-A		NOS	44		
4	FIELD CALL STATION (FCS) TYPE-B		NOS	86		
5	DESKTOP STATION (DTS)		NOS	26		
6	FIELD CALL STATION (FCS) TYPE-D (FLAMEPROOF)		NOS	5		
7	CONE TYPE SPEAKER		NOS	42		
8	HORN TYPE SPEAKER - 15W		NOS	112		
9	FALSE CEILING TYPE SPEAKER		NOS	24		
10	EXTENSION AMPLIFIER FOR MCS, FMS & DTS		NOS	7		
11	FLOOR MOUNTED ACOUSTIC BOOTH		NOS	16		
12	ACOUSTIC HOOD		NOS	18		
13	PORTABLE HANDSET STATION WITH MULTI-PIN PLUG		NOS	1		
14	SOCKET BOX FOR PORTABLE HANDSET STATION		NOS	1		
15	MISC. ITEMS (As per Annexure-3A)		LOT	1		
16	PA SYSTEM CABLE (As per Annexure-3B)		LOT	1		
17	ERECTION HARDWARE (AS PER ANNEXURE-3C)		LOT	1		
18	O&M SPARE (RECOMMENDED SPARES) (Bidder to furnish list as per ANNEXURE-3D)		LOT	1		
19	SPECIAL TOOLS & TACKLES (Bidder to furnish list per ANNEXURE-3E)		LOT	1		
20	E&C SPARE (Bidder to furnish list as per ANNEXURE-3F)		SET	1		
Notes						
1	ITEM WISE PRICES WITH QUANTITY OF EACH ITEM OF FOLLOWING SHALL BE FURNISHED ALONG WITH BID:					
a)	MISC. ITEMS-AS PER ANNEXURE-3A					
b)	PA SYSTEM CABLE-AS PER ANNEXURE-3B					
c)	ERECTION HARDWARE- AS PER ANNEXURE-3C					
d)	O&M SPARE (RECOMMENDED SPARES)- AS PER ANNEXURE-3D					
e)	SPECIAL TOOLS & TACKLES - AS PER ANNEXURE-3E					
f)	E&C SPARE - AS PER ANNEXURE-3F					
2	ADDITION/DELETION OF QUANTITIES SHALL BE APPLICABLE AT THE QUOTED PRICES. THE UNIT RATE OF SUPPLY OF ALL EQUIPMENTS AND SERVICES QUOTED BY THE BIDDERS SHALL BE FIRM FOR A VARIATION OF QUANTITIES, WHICH MAY BE TO THE EXTENT OF +/- 30% OF TOTAL EX. WORKS VALUE DERIVED BASED ON THE ORDERED QUANTITY.					
3	BIDDERS SHALL FURNISH THE REPORTS OF THE TYPE TEST FOR THE EQUIPMENTS/ITEMS ORDERED UNDER THIS CONTRACT. IN CASE BIDDER IS NOT ABLE TO SUBMIT REPORT OF TYPE TEST(S), OR IN CASE TYPE TEST REPORTS ARE NOT FOUND TO BE MEETING THE SPECIFICATION/RELEVANT STANDARD REQUIREMENTS, THEN TYPE TESTING SHALL BE CONDUCTED UNDER THIS CONTRACT WITHOUT ANY COMMERCIAL IMPLICATION TO BHEL, AND REPORTS SHALL BE SUBMITTED FOR APPROVAL. NO CHARGES SHALL BE PAID FOR TESTING UNDER SUCH CIRCUMSTANCES.					
4	SUPPLY, FABRICATION & PAINTING OF SUPPORT STRUCTURE FOR PA SYSTEM EQUIPMENT SHALL BE IN BIDDER'S SCOPE.					
5	SUPPLY, TERMINATION AND LAYING OF CABLE REQUIRED OF PA SYSTEM SHALL BE IN BIDDER'S SCOPE.					
6	INSTRUMENTS REQUIRED FOR TESTING & COMMISSIONING SHALL BE ARRANGED BY THE BIDDER AND SHALL BE TAKEN BACK BY BIDDERS.					

1X 800 MW KOTHAGUDEM TPS					
Annexure-3A Misc. Items					
Sl. No.	Item Name	UOM	Quantity	Unit Price (Rs)(Ex-works) AISHAN	Total Rate(Rs)(Ex-works) AISHAN
1	INDUSTRIAL NETWORK/ ETHERNET DISTRIBUTION SWITCH (24 PORT)	NOS	10		
2	CABINET TO HOUSE ETHERNET SWITCH & PASSIVE FIBER OPTIC COMPONENTS AND TERMINATION KIT	Lot (as required)	10		
3	UPS	NOS	10		
4	LAPTOP WITH PA SYSTEM SOFTWARE	NOS	3		
5	WALL MOUNTED DB (16 OUTGOING)	NOS	1		
8	(Additional item, if required for completeness of system Such As Passive Fiber Optic Components and termination kit consisting of Fiber panel, Information outlet, LIU, face plates, SC Coupler, Fiber Optic Drawer with Pigtail, various connectors (Bidder to furnish list))	Lot	1		
Note:	The above quantity and type are tentative, Amount will be payable as per actual.				

1 X 800 MW KOTHAGUDEM TPS					
Annexure-3B PA system Cable					
Sl. No.	Item Name	UOM	Quantity	Unit Rate (Rs.) (Ex. Works)	Total Rate (Rs.) (Ex. Works)
1	FO Cable	meter	3000		
2	Cat-6 Cable	meter	3000		
3	Cable for Speaker	meter	1000		
4	Power Cable	meter	100		
5	Any other cable (if required)	meter			

Note:

- 1 The above quantity and type are tentative, Amount will be payable as per actual.
- 2 Refer clause no 8.27.01 to 8.27.13 of technical specification for any additional cable/items requirement

1 X 800 MW KOTHAGUDEM TPS

Annexure-3C PA system Erection Hardware

Sl. No.	Item Name	UOM	Quantity	Unit Rate (Rs.) (Ex. Works)	Total Rate (Rs.) (Ex. Works)
1	Rigid Conduit	meter	2000		
2	Flexible Conduit	meter	1000		
3	Special Fitting	Lot	1		
4	Distribution Frames & Junction Boxes	Nos	50		
5	Cable Glands	Nos	130		
6	Earthing wire	meter	300		

NOTE

1 The above quantity and type are tentative, Amount will be payable as per actual.

1X 800 MW KOTHAGUDEM TPS						
Annexure-3D O&M Spare (Recommended Spares for 3 years)						
Sl. No.	Item Name	MAKE & MODEL	UOM	Quantity	Unit Price (Rs)(Ex-works)	Total Price(Rs)(Ex-works)
1						
Notes:						
1	Bidder to submit a list in above format of recommended spare parts for three (3) years satisfactory and trouble-free operation, indicating the itemized price of each item of the spares. The final quantity shall be decided during detail engineering and amount shall be payable as per actual supplied quantities.					

1 X 800 MW KOTHAGUDEM TPS**Special Tools & Tackles - As per Annexure-3E**

Sl. No.	Item Name	MAKE & MODEL	UOM	Quantity	Unit Price (Rs)(Ex-works)	Total Price(Rs)(Ex-works)	
1							

Notes:

1	Bidder to submit a list in above format of special tools & tackles, indicating the itemized price of each item. The final quantity shall be decided during detail engineering and amount shall be payable as per actual supplied quantities.
---	--

1 X 800 MW KOTHAGUDEM TPS**E&C Spare- As per Annexure-3F**

Sl. No.	Item Name	MAKE & MODEL	UOM	Quantity	Unit Price (Rs)(Ex-works)	Total Price(Rs)(Ex-works)
1						

Notes:

1	Bidder to submit a list in above format of E&C spare, indicating the itemized price of each item. The final quantity shall be decided during detail engineering and amount shall be payable as per actual supplied quantities.
---	--

**1 X 800 MW KOTHAGUDEM TPS
BOQ CUM PRICE SCHEDULE FOR PA SYSTEM (E&C)-ANNEXURE-4**

Sl. No.	Item Name	UOM	Quantity	Unit Rate (Rs.) (Ex. Works)	Total Rate (Rs.) (Ex. Works)
(B)	E&C				
Sl. No.	Item Name	UOM	Quantity	Unit Rate (Rs.) (Ex. Works)	Total Rate (Rs.) (Ex. Works)
1	IP BASED PA CONTROLLER	NOS	2		
2	MASTER CONTROL STATION (MCS) WITH EXTENSION AMPLIFIER	NOS	7		
3	FIELD CALL STATION (FCS) TYPE-A	NOS	44		
4	FIELD CALL STATION (FCS) TYPE-B	NOS	86		
5	DESKTOP STATION (DTS)	NOS	26		
6	FIELD CALL STATION (FCS) TYPE-D (FLAMEPROOF)	NOS	5		
7	CONE TYPE SPEAKER	NOS	42		
8	HORN TYPE SPEAKER - 15W	NOS	112		
9	FALSE CEILING TYPE SPEAKER	NOS	24		
10	EXTENSION AMPLIFIER FOR MCS, FMS & DTS	NOS	7		
11	FLOOR MOUNTED ACOUSTIC BOOTH	NOS	16		
12	ACOUSTIC HOOD	NOS	18		
13	SOCKET BOX FOR PORTABLE HANDSET STATION	NOS	1		
14	MISC ITEMS (AS PER ANNEXURE-4A)	LOT	1		
15	PA SYSTEM CABLE (AS PER ANNEXURE-4B)	LOT	1		
16	ERECTION HARDWARE (AS PER ANNEXURE-4C)	LOT	1		

Notes

1	ITEM WISE PRICES WITH QUANTITY OF EACH ITEM OF FOLLOWING SHALL BE FURNISHED ALONG WITH BID:
a)	MISC. ITEMS-AS PER ANNEXURE-4A
b)	PA SYSTEM CABLE-AS PER ANNEXURE-4B
c)	ERECTION HARDWARE- AS PER ANNEXURE-4C
2	ADDITION/DELETION OF QUANTITIES SHALL BE APPLICABLE AT THE QUOTED PRICES. THE UNIT RATE OF SUPPLY OF ALL EQUIPMENTS AND SERVICES QUOTED BY THE BIDDERS SHALL BE FIRM FOR A VARIATION OF QUANTITIES, WHICH MAY BE TO THE EXTENT OF +/- 30% OF TOTAL EX. WORKS VALUE DERIVED BASED ON THE ORDERED QUANTITY.
3	BIDDERS SHALL FURNISH THE REPORTS OF THE TYPE TEST FOR THE EQUIPMENTS/ITEMS ORDERED UNDER THIS CONTRACT. IN CASE BIDDER IS NOT ABLE TO SUBMIT REPORT OF TYPE TEST(S), OR IN CASE TYPE TEST REPORTS ARE NOT FOUND TO BE MEETING THE SPECIFICATION/RELEVANT STANDARD REQUIREMENTS, THEN TYPE TESTING SHALL BE CONDUCTED UNDER THIS CONTRACT WITHOUT ANY COMMERCIAL IMPLICATION TO BHEL, AND REPORTS SHALL BE SUBMITTED FOR APPROVAL. NO CHARGES SHALL BE PAID FOR TESTING UNDER SUCH CIRCUMSTANCES.
3	SUPPLY, FABRICATION & PAINTING OF SUPPORT STRUCTURE FOR PA SYSTEM EQUIPMENT SHALL BE IN BIDDER'S SCOPE..
4	SUPPLY, TERMINATION AND LAYING OF CABLE REQUIRED OF PA SYSTEM SHALL BE IN BIDDER'S SCOPE.
5	INSTRUMENTS REQUIRED FOR TESTING & COMMISSIONING SHALL BE ARRANGED BY THE BIDDER AND SHALL BE TAKEN BACK BY BIDDERS.

1 X 800 MW KOTHAGUDEM TPS

Annexure-4A Misc. Items (E&C)

Sl. No.	Item Name	UOM	Quantity	Unit Rate (Rs.) (Ex. Works)	Total Rate (Rs.) (Ex. Works)
1	INDUSTRIAL NETWORK/ ETHERNET DISTRIBUTION SWITCH (24 PORT)	NOS	10		
2	CABINET TO HOUSE ETHERNET SWITCH & PASSIVE FIBER OPTIC COMPONENTS AND TERMINATION KIT	Lot (as required)	10		
3	UPS	NOS	10		
2	WALL MOUNTED DB (16 OUTGOING)	NOS	1		
8	(Additional item, if required for completeness of system Such As Passive Fiber Optic Components and termination kit consisting of Fiber panel, Information outlet, LIU, face plates, SC Coupler, Fiber Optic Drawer with Pigtail, various connectors (Bidder to furnish list))	Lot	1		
The above quantity and type are tentative, Amount will be payable as per actual.					

1 X 800 MW KOTHAGUEDEM TPS**Annexure- 4B PA system Cable (E&C)**

Sl. No.	Item Name	UOM	Quantity	Unit Rate (Rs.) (Ex. Works)	Total Rate (Rs.) (Ex. Works)
1	FO Cable	meter	3000		
2	Cat-6 Cable	meter	3000		
3	Cable for Speaker (1Px1.5 Sq.mm)	meter	1000		
4	Power Cable	meter	100		
5	Any other cable (if required)	meter			
Note:	The above quantity and type are tentative, Amount will be payable as per actual.				

1 X 800 MW KOTHAGUDEM TPS					
Annexure-4C PA system Erection Hardware (E&C)					
Sl. No.	Item Name	UOM	Quantity	Unit Rate (Rs.) (Ex. Works)	Total Rate (Rs.) (Ex. Works)
1	Rigid steel Conduit	meter	2000		
2	Flexible Conduit	meter	1000		
3	Special Fitting	Lot	1		
4	Distribution Frames & Junction Boxes	Nos	50		
5	Cable Glands	Nos	130		
6	Earthing wire	meter	300		

1 The above quantity and type are tentative, Amount will be payable as per actual.



TECHNICAL SPECIFICATION FOR
IP BASED PUBLIC ADDRESS SYSTEM

1X800 MW KOTHAGUDEM TPS

SPECIFICATION NO. PE-TS-410-557-E001

VOLUME II B

SECTION -

REVISION 0

DATE: 19.10.2015

SHEET 1 OF 1

ANNEXURE – 5

(VENDOR DRAWING/DOCUMENT SCHEDULE)

S. NO.	DESCRIPTION	THROUGH DMS	HARD PRINTS	CD-ROMs
1	Docs. /drgs. for approval (First submission)	YES	-	-
2	Docs. / drgs. for approval (Second & subsequent submission till approval)	YES	-	-
3	Final approved docs. / drgs. for Distribution	YES	As per NIT	As per NIT
4.	Instruction Manual (Erection,/O&M), commissioning procedure, etc.	6	YES IN PDF	1
5.	Test Reports	1	YES IN PDF	1

**1X800 MW KOTHAGUDEM TPS
PA SYSTEM [DOCUMENT NUMBERING]**

Sl.No	BHEL DRAWING NO.	TITLE
1	PE-V0-410-557-E001	DATA SHEET FOR PA SYSTEM
2	PE-V0-410-557-E002	GA OF PA CONTROLEER
3	PE-V0-410-557-E003	GA OF MASTER CONTROL STATION
4	PE-V0-410-557-E004	GA OF FIELD CALL STATION
5	PE-V0-410-557-E005	GA OF DESKTOP STATION
6	PE-V0-410-557-E007	GA OF Misc. Items of PA System
7	PE-V0-410-557-E009	GA OF ACOUSTIC HOOD
8	PE-V0-410-557-E010	GA OF ACOUSTIC BOOTH
9	PE-V0-410-557-E011	GA OF EXTENSION AMPLIFIER
10	PE-V0-410-557-E012	GA OF FALSE CEILING TYPE LOUD SPEAKER
11	PE-V0-410-557-E013	GA OF PORTABLE STATION
12	PE-V0-410-557-E014	GA OF CONE TYPE LOUD SPEAKER
13	PE-V0-410-557-E015	GA OF HORN TYPE LOUD SPEAKER
14	PE-V0-410-557-E016	GA AND DATA SHEET OF ERECTION HARDWARE
15	PE-V0-410-557-E020	GA OF SOCKET FOR PORTABLE STATION
16	PE-V0-410-557-E021	GA OF ETHERNET SWITCH
17	PE-V0-410-557-E023	TECHNICAL DATA SHEET FOR ETHERNET SWITCH
18	PE-V0-410-557-E024	TECHNICAL DATA SHEET FOR CABLES
19	PE-V0-410-557-E025	O&M MANUAL FOR PA SYSTEM
20	PE-V0-410-557-E026	BLOCK DIAGRAM FOR PA SYSTEM
21	PE-V0-410-557-E027	CABLE SCHEDULE FOR PA SYSTEM
22	PE-V0-410-557-E028	CABLE INTERCONNECTION DIAGRAM FOR PA SYSTEM
23	PE-V0-410-557-E029	TYPE TEST PROCEDURE FOR PA SYSTEM
24	PE-V0-410-557-E030	TYPE TEST REPORT FOR PA SYSTEM
25	PE-V0-410-557-E901	QUALITY PLAN FOR PA SYSTEM

NOTE

IF ANY OTHER DRAWING IS REQUIRED TO BE SUBMITTED DURING DETAIL ENGINEERING, DRAWING NUMBER OF THE SAME SHALL BE FURNISHED AT THAT TIME.

1003-755-014-DG-3E DN GND/DRAWN

ANNEXURE-I

LEGEND:

N/S SW NETWORK SWITCH

↔ OPTICAL FIBER CABLE

NOTES:

1. LOCATION OF CALL STATIONS, NETWORK SWITCHES ETC SHALL BE FINALISED DURING DETAIL ENGINEERING.
2. ALL THE INTERCONNECTING CABLES BETWEEN NETWORK SWITCHES SHALL BE FIBER OPTIC CABLE.
3. SIGNAL CABLES FROM NETWORK SWITCH TO CALL STATION SHALL BE CAT 6 UPTO A DISTANCE OF 100M. FOR DISTANCE GREATER THAN 100M CABLE SHALL BE FIBER OPTIC.

REV.	DATE	ALTD.	CHD.	APPD.	REV.	DATE	ALTD.	CHD.	APPD.	JOB NO.	410
STATUS CONTRACT											
DISTRIBUTION											
TO					NO						
<div style="display: flex; justify-content: space-between; align-items: center;"> <div style="width: 45%;"> <p style="text-align: center; font-weight: bold;">1X800MW KOTHAGUDEM TPS</p> </div> <div style="width: 50%; text-align: right;">  <p>BHARAT HEAVY ELECTRICALS LTD. POWER SECTOR ENGINEERING MANAGEMENT NEW DELHI</p> </div> </div>											
<p>TITLE BLOCK DIAGRAM FOR PUBLIC ADDRESS SYSTEM</p>											
DEPT	CODE	DRNL	MS	NAME	SIGN	DATE					
E	MS	AKR	SGK	MS	-SD-						
DRAWING NO. PE-DG-410-557-E001											
SHEET	02	OF	02	REV.	04						

ANNEXURE-1

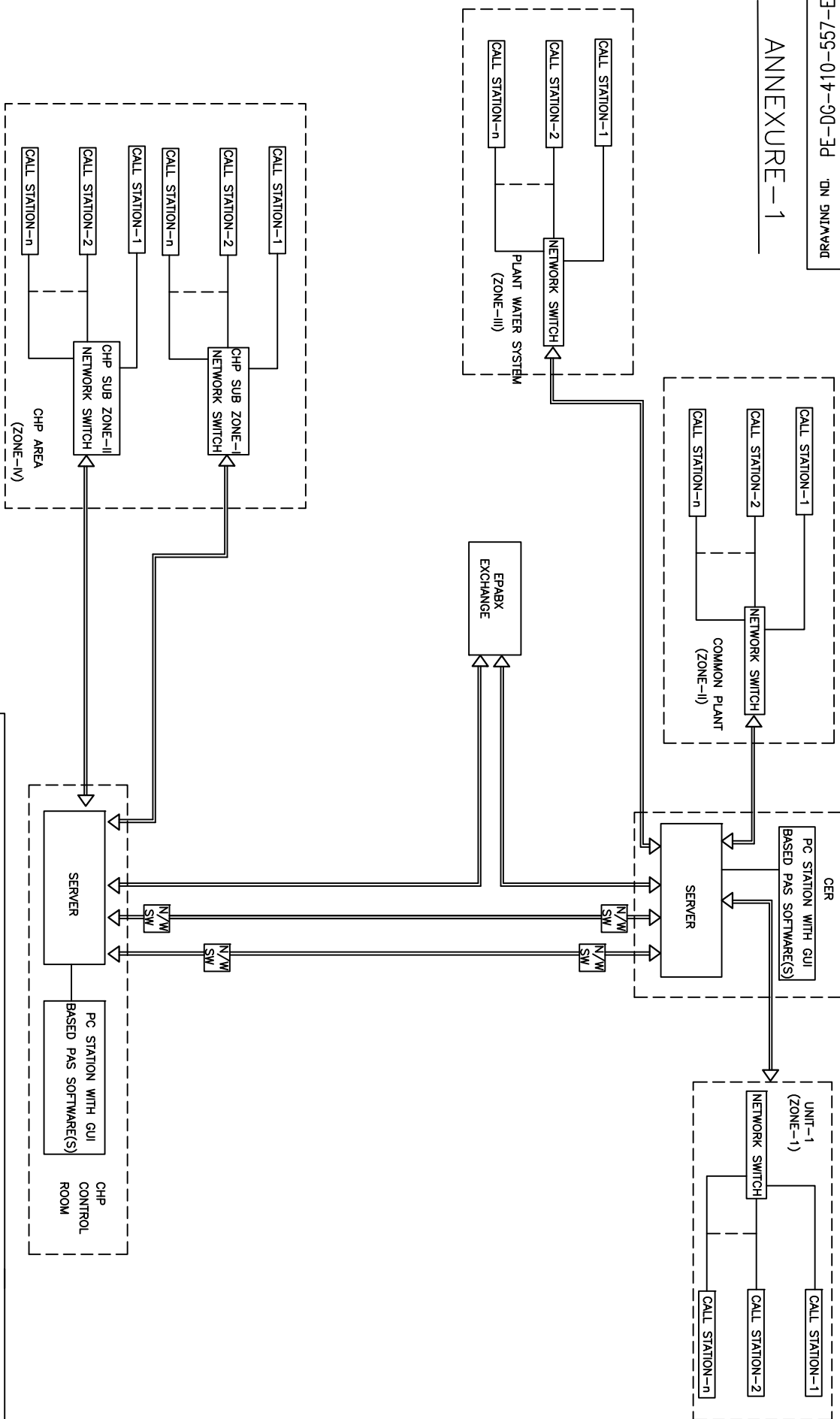

1X800MW KOTHAGUDEM TPS



BHARATI HEAVY ELECTRICALS LTD.
POWER SECTOR
PROJECT ENGINEERING MANAGEMENT
NEW DELHI

DEPT	DRNL	NAME	SIGN	DATE
CODE	DSGN	MS	-SD-	
E	CHD	AKR	-SD-	
	APPD	SKG	-SD-	

REV.	DATE	ALT.D.	CHD.	APPD.	REV.	DATE	ALT.D.	CHD.	APPD.	JOB NO.
										410

STATUS		CONTRACT	
TO			
NO			

TITLE
SYSTEM BLOCK DIAGRAM FOR
PUBLIC ADDRESS SYSTEM

DRAWING NO.		SHEET		DF		REV.	
PE-DG-410-557-E001		01	02	02	04		



TITLE

TECHNICAL SPECIFICATION
FOR
PUBLIC ADDRESS SYSTEM

SPECIFICATION NO. PE-TS-410-557-E001

VOLUME IIB

SECTION D

REV 0 DATE 19.10.2015

SHEET 1 OF 8

PUBLIC ADDRESS SYSTEM

SPECIFICATION NO. PE-TS-410-557-E001, Rev. 0



TITLE

TECHNICAL SPECIFICATION
FOR
PUBLIC ADDRESS SYSTEM

SPECIFICATION NO. PE-TS-410-557-E001

VOLUME IIB

SECTION D

REV 0 DATE 19.10.2015

SHEET 2 OF 8

**GENERAL REQUIREMENT OF
ERECTION AND COMMISSIONING**



TITLE

**TECHNICAL SPECIFICATION
FOR
PUBLIC ADDRESS SYSTEM**

SPECIFICATION NO. PE-TS-410-557-E001

VOLUME IIB

SECTION D

REV 0 DATE 19.10.2015

SHEET 3 OF 8

CONTENTS

- 1.0 GENERAL
- 2.0 CODES AND STANDARDS
- 3.0 INSTALLATION
 - 3.1 PA SYSTEM EQUIPMENT INSTALLATION
 - 3.2 ITEMS OF SUPPLY FOR CABLING INSTALLATION WORK
 - 3.3 INSTALLATION OF CABLES AND CONDUITS
 - 3.4 ADDITIONAL POINTS OF CONSIDERATION
- 4.0 QUANTITY MEASUREMENT AND WASTAGE ALLOWANCE
 - 4.1 MEASUREMENT OF QUANTITIES
 - 4.2 CUTTING AND WASTAGE ALLOWANCE
- 5.0 TESTING
 - 5.1 SITE TESTS
 - 5.2 GENERAL REQUIREMENTS OF SITE TESTING
- 6.0 PRICES
 - 6.1 GENERAL
 - 6.2 UNIT PRICES OF INSTALLATION WORK



TITLE

TECHNICAL SPECIFICATION FOR PUBLIC ADDRESS SYSTEM

SPECIFICATION NO. PE-TS-410-557-E001

VOLUME IIB

SECTION D

REV 0 DATE 19.10.2015

SHEET 4 OF 8

1.0 GENERAL

The scope of this specification covers handling and storage at site; installation, testing and commissioning of Public Address System for efficient and trouble free operation after installing the same at site.

2.0 CODES AND STANDARDS

The installation shall comply with all currently applicable statutes, regulations and safety codes in the locality where the equipment will be installed. Nothing in this specification shall be construed to relieve the vendor of his responsibility.

3.0 INSTALLATION

The contractor shall carry out total installation work as per the requirements of the specification and instructions of Engineer.

3.1 PA SYSTEM EQUIPMENT INSTALLATION

3.1.1 Installation of PA System equipment shall include erection, connection, grounding, testing and commissioning of the equipment. Installation activity shall also include provision of all fittings, supports, hangers and other accessories which are not specifically mentioned but are required to complete the installation work.

3.1.2 Equipment shall be brought to the place of work only at the time of erection. Unpacking, handling, assembling and erection shall be as per the guidelines of installation manual and Field Quality Plan.

3.1.3 Erection shall commence in an area only after the clearance has been obtained from the Engineer. Vendor shall ensure that all activities, which are liable to damage the equipment in that area, have been completed.

3.1.4 The drilling and welding of building steel work for fixing supports and brackets shall not be done without the prior approval of Engineer.

3.1.5 Wherever drilling and welding of building steel work for fixing supports and brackets is done, the same shall be re-painted and restored to the same paint shade as per site requirement at no extra cost to purchaser.

3.2 ITEMS OF SUPPLY FOR CABLING INSTALLATION WORK

The supply of below listed items shall be considered to be part of cabling installation work:

3.2.1 Cable glands

Cable glands shall be single or double compression type as per Data Sheet A. Material of glands shall be brass. Nickel plating shall be provided if indicated in Data Sheet A. Rubber components used in the gland shall be of neoprene. Name/ trade name of manufacturer, type no. and applicable range of outer diameter of cable shall be engraved/ printed on the cable gland.

3.2.2 Cable lugs

Cable lugs shall be of tinned copper. Name/ trade name and size shall be engraved/ printed on each cable lug.

3.2.3 Self Locking Clamps

Clamps shall be of nylon material having self-locking feature when the cord is looped. They shall be provided with manual lock release. Clamp cord shall not move in the backward direction once it has been locked, unless the lock release is depressed.



TITLE

TECHNICAL SPECIFICATION FOR PUBLIC ADDRESS SYSTEM

SPECIFICATION NO. PE-TS-410-557-E001

VOLUME IIB

SECTION D

REV 0 DATE 19.10.2015

SHEET 5 OF 8

3.2.4 Ferrules

Ferrules shall be required for individual core of cables hence they shall be suitable for the insulated conductor diameter. They shall be of plastic material. Numbering on the ferrules shall be engraved type. Colour of base shall be yellow and that of engraving shall be black. Engrave colouring shall be of durable quality to match the entire life of the plant. Engraving shall be legible from a distance of 600 mm. Ferrules shall be interlocked type such that the interlocked ferrules take the shape of tube with complete ferrule number marked in a straight line.

3.2.5 Tags

For identification, cables shall be provided with cable number tags of durable fibre, aluminium or stainless steel sheets. Cable numbers shall be engraved type in case of aluminium or stainless steel tags, and printed type in case of fibre sheet. Tags shall be of durable quality of size 60mm x 12mm with a tie hole at each end and shall be provided with non-corrosive wire of sufficient strength for tagging.

3.3 INSTALLATION OF CABLES AND CONDUITS

3.3.1 All cables shall be provided with identification tags indicating the cable numbers in accordance with the cable circuit schedule. Tags shall be fixed at both ends of cables and on both sides of floor/ wall crossings.

3.3.2 All cable entries in the equipment shall be sealed by cable glands.

3.3.3 Power cable terminations shall be carried out in such a manner as to avoid strain on the terminals by providing suitable clamps near the terminals.

3.3.4 Control cable cores entering the equipment or control panels shall be neatly bunched and strapped with PVC perforated tapes/ nylon ties and suitably supported to keep them in position at the terminal block. Copper conductor control cables shall be terminated directly into screw type terminals provided in the equipment.

3.3.5 Wherever control cables are to be terminated by means of terminal lugs, the same shall be of tinned copper compression type.

3.3.6 All spare cores shall be connected to spare terminals wherever possible. If spare terminals are not available, spare cores shall be neatly dressed and suitably taped at both ends.

3.3.7 Individual cores of control cables shall have ferrules for identification. Ferrule numbers shall be provided as per the control schemes and other related documents supplied by the purchaser.

3.4 ADDITIONAL POINTS OF CONSIDERATION

3.4.1 The installation work shall be carried out in a neat workman-like manner by skilled, experienced and competent workmen.

3.4.2 Installation shall be properly coordinated at site with other services and wherever necessary suitable adjustment shall be made to avoid interference with any part of the building, structures, equipment, utilities and services. Any such adjustment shall be done with the approval of Engineer.

3.4.3 All materials being supplied or consumed during erection by the vendor in the process of erection work shall be of the best quality and according to the relevant standards. All materials shall be got inspected and approved by the Engineer before the same is used for erection work.



TITLE

TECHNICAL SPECIFICATION FOR PUBLIC ADDRESS SYSTEM

SPECIFICATION NO. PE-TS-410-557-E001

VOLUME IIB

SECTION D

REV 0 DATE 19.10.2015

SHEET 6 OF 8

3.4.4 Any work like chipping/ breaking of existing structure like walls, floors, fabrications, etc. shall be done after taking prior approval of Engineer.

3.4.5 Any wrong erection shall be removed & re-erected promptly to comply with the design requirements to the satisfaction of Engineer. Re-erection shall be done at no extra cost to the purchaser.

3.4.6 While testing and commissioning, if the system is observed to be not functioning, it shall be the responsibility of the contractor to check, rectify and demonstrate that the defect has been removed to the satisfaction of purchaser.

3.4.7 Before energisation of system, physical inspection shall be carried out and all foreign bodies shall be removed and loose connecting bolts etc. shall be tightened.

4.0 QUANTITY MEASUREMENT AND WASTAGE ALLOWANCE

4.1 MEASUREMENT OF QUANTITIES

4.1.1 For all payment purposes, measurement shall be made on the basis of the execution drawings/ physical measurements. Physical measurements shall be made by the contractor in the presence of the Engineer.

4.1.2 Wastage allowance shall be kept in consideration while making material appropriation of supplied items.

4.2 CUTTING AND WASTAGE ALLOWANCE

Vendor shall carefully plan the cutting schedule of each cable drum such that wastages are minimised and any resultant short lengths can be used where appropriate route lengths are available.

5.0 TESTING

5.1 Site Tests

5.1.1 After assembly, all major equipment together are to be site tested to establish the workability of the system at site.

5.1.1.1 Following tests are to be performed at site:

- a) Insulation resistance, HV test for cables.
- b) Rated output power.
- c) Performance of PAGE and PRIVATE channels for all equipments in the entire Public Address System.
- d) Proper functioning of auto-changeover unit.
- e) Test to ensure that db level of announcement at any station by its own handset shall be lower than announcement at the same station by any other handset.

5.1.1.2 Bidder to perform all site tests as per the Field Quality Plan. During contract stage bidder to furnish details of these tests & the standards to which these conform for purchasers approval.

5.2 General Requirements of Site Testing

5.2.2.1 The Owner may ask for any tests at site which in his opinion are necessary to determine that the works comply with the specification, manufacturer's instruction or the applicable IS code of installation. The Contractor shall be responsible for conducting the tests and shall bear the cost of such additional tests.



TITLE

TECHNICAL SPECIFICATION FOR PUBLIC ADDRESS SYSTEM

SPECIFICATION NO. PE-TS-410-557-E001

VOLUME IIB

SECTION D

REV 0 DATE 19.10.2015

SHEET 7 OF 8

5.2.2.2 The contractor shall have to bring all testing equipment & instruments to carry out the job. All instruments shall be calibrated to the satisfaction of the Engineer before actual testing and tests shall be conducted by qualified & experienced personnel.

5.2.2.3 All documents/ records regarding test data and all other measured values shall be submitted to Engineer for approval and subsequent record and reference. The results of all tests shall conform to the specification requirements as well as any specific performance data guaranteed during finalisation of contract.

6.0 PRICES

6.1 GENERAL

Unit prices listed out in this clause shall be applicable for payment to the contractor for activities covered under this specification. The following shall be kept in consideration while quoting the prices:

6.2 UNIT PRICES OF INSTALLATION WORK

Detailed requirement for all the items are given in the specifications, Data Sheet A and Annexures.

- a) Unit price of installation shall include transportation of materials from Vendor's/ Owner's storage yard to work site, handling, testing before erection, testing after erection and commissioning of materials including supply and installation of all associated materials (including support materials) and consumables, carrying out of all associated minor civil works and furnishing of all skilled/ unskilled labour, supervisory and commissioning staff.
- b) Price of earth connections are to be included in the erection price of equipment as above.
- c) No separate prices shall be applicable for termination of cables. Cable termination shall include drilling of gland plates, fixing of glands, ferrules and lugs and connection to the equipment.
- d) Purchaser reserves the right to delete/ add any of the equipment or services from the bidder's scope of work.
- e) The unit prices quoted shall be for supply and/ or installation as explained in detail in the clauses in subsequent paragraphs. No other prices shall be applicable for the purpose of payment.
- f) While quoting the prices for installation, the following shall be considered as part of job:
 - i. Cable glands and lugs
 - ii. Clamps, ferrules, aluminium/ stainless steel tags as per the project requirements
 - iii. Fasteners like nuts, bolts, washers, spring washers, rawl plugs, anchoring bolts and lugs etc.
 - iv. Conduit plugs, gaskets, couplers, and insulated bushings
 - v. Sealing compounds for wall and floor openings
 - vi. Consumables like enamels, cold zinc paint, electrodes for welding etc.
 - vii. Materials for minor civil works
- g) The following shall be arranged by the contractor at no extra cost:
 - i. All unskilled and skilled labour
 - ii. All supervisory and commissioning staff
 - iii. All facilities/ equipment for site fabrication such as cutting, bending and drilling equipment
 - iv. Welding set(s)
 - v. Material handling equipment
 - vi. All special tools and tackles for erection
 - vii. All testing equipment
- h) Requirement of Quality Plan and Field Quality Plan shall be considered in the quoted prices.



TITLE

**TECHNICAL SPECIFICATION
FOR
PUBLIC ADDRESS SYSTEM**

SPECIFICATION NO. PE-TS-410-557-E001

VOLUME IIB

SECTION D

REV 0 DATE 19.10.2015

SHEET 8 OF 8

- i) E & C spares required shall be part of E & C charges.
- j) Instruments required fro testing & commissioning shall be arranged by the contractor and shall be taken back after E & C.
- k) Fabrication and painting of support structures of various equipments shall be in contractor's scope. However structural steel shall be free issue by BHEL.



TITLE PUBLIC ADDRESS SYSTEM Datasheet B	SPECIFICATION NO.	PE-TS-410-557-E-001
	VOLUME	IIB
	SECTION	D
	REV 0	DATE 19/10/2015
	SHEET	1 OF 5

DATA SHEET – B

To be submitted alongwith Bid

S.NO.	DESCRIPTION	PARTICULARS	UNIT
1.0	SYSTEM DESIGN DATA		
1.1	Design ambient temperature :	°C	
2.0	APPLICABLE STANDARDS		
2.1	Whether all standards specified in Annexure I of Data Sheet A followed :	<input type="checkbox"/> Yes <input type="checkbox"/> No	
3.0	COMPLETE SYSTEM REQUIREMENTS		
a)	Frequency response :	Hz	
b)	Hum & noise level or signal to noise level :		
4.0	SCOPE OF SYSTEM DESIGN : ENGINEERING	<input type="checkbox"/> Included <input type="checkbox"/> Excluded	
5.0	POWER SUPPLY		
5.1	Whether the system suitable for operation for power supply details given in specification and Data Sheet A. :	<input type="checkbox"/> Yes <input type="checkbox"/> No	
5.2	Power supply requirement at 240V AC :	kVA	
6.0	CONSTRUCTIONAL REQUIREMENTS		
6.5	AMPLIFIERS : (To be furnished separately for each type of amplifier)	Pre- Line Loud Speaker Amplifier Amplifier Amplifier	
a)	Name of the manufacturer :		
b)	Type and manufacturer's catalogue no. :		
c)	Power supply details :		
d)	Full load consumption(VA) :		
e)	Rated load (W/Ohm): output impedance		



TITLE

PUBLIC ADDRESS SYSTEM
Datasheet B

SPECIFICATION NO. PE-TS-410-557-E-001

VOLUME IIB

SECTION D

REV 0 DATE 19/10/2015

SHEET 2 OF 5

- f) Output voltage (V) :
- g) Frequency response (Hz) :
- h) Noise level (db) :
- i) Controls provided
- i. Cont. variable : Yes No
volume control
- ii. Standby and idle : Yes No
time power supply
cut-off arrangement
arrangement
- j) Sensitivity w.r.t. (mV):
nominal output

6.6 HANDSETS

6.6.1 Master Handset Station(s)

- a) Name of the manufacturer :
- b) Type and manufacturer's catalogue no. :
- c) Material :
- d) Degree of protection :
- e) Surface treatment :
- f) Whether all features : Yes No
provided on master
handset station as per
specification requirements
- g) Type of circuit protection:
- h) Mounting arrangement :

6.6.2 HANDSETS (To be furnished separately for each type)

Outdoor/ Indoor
Indoor desk mtd.
Wall mtd.

- a) Name of the manufacturer :
- b) Type and manufacturer's catalogue no. :
- c) Material :



TITLE PUBLIC ADDRESS SYSTEM Datasheet B	SPECIFICATION NO.	PE-TS-410-557-E-001
	VOLUME	IIB
	SECTION	D
	REV 0	DATE 19/10/2015
	SHEET	3 OF 5

- d) Frequency response of : Hz
the transmitter
- e) Receiver output : mV
- f) Receiver frequency : Hz
response
- g) Degree of protection & :
weather proofing
arrangement

6.7 LOUDSPEAKERS (To be furnished Reentrant Cone
separately for each type)

- a) Name of the manufacturer :
- b) Type and manufacturer's :
catalogue no.
- c) Material :
- d) Degree of protection :
- e) Impedance matching volts : ohm
(Transformer details)
- f) Output power
- i. rms : Watt
- ii. Peak : Watt
- g) Frequency response : Hz
- h) Cut-off frequency : Hz
- i) Sound level at 1000 Hz :
db/watt mtr. distance
- j) Bell diameter : mm
- k) Acoustic length : mm

6.8 JUNCTION BOX

- a) Name of the manufacturer :
- b) Type :



TITLE PUBLIC ADDRESS SYSTEM Datasheet B	SPECIFICATION NO.	PE-TS-410-557-E-001
	VOLUME	IIB
	SECTION	D
	REV 0	DATE 19/10/2015
	SHEET	4 OF 5

- c) Construction :
- d) Material :
- e) Sheet steel thickness : mm
- f) Number of ways :
- g) Degree of protection :

6.9 MAIN DISTRIBUTION BOX/ MAIN JUNCTION BOX

- a) Name of the manufacturer :
- b) Type :
- c) Construction :
- d) Material :
- e) Sheet steel thickness : mm
- f) Number of ways :
- g) Degree of protection :

6.10 Required Scheme as per section D
 Scheme I [] Scheme II []

6.16 COMMON REQUIREMENTS OF VARIOUS EQUIPMENTS

6.16.1 Surface Treatment

- a) If painted;
 - i. Application :
 - ii. Colour of paint
 - 1. Inside :
 - 2. Outside :
 - iii. Minimum thickness : microns
- b) If galvanized;
 - i. Method :
 - ii. Applicable Standard :



TITLE PUBLIC ADDRESS SYSTEM Datasheet B	SPECIFICATION NO.	PE-TS-410-557-E-001
	VOLUME	IIB
	SECTION	D
	REV 0	DATE 19/10/2015
	SHEET	5 OF 5

iii. Minimum thickness : microns
of zinc deposit on
all points

iv. Weight of zinc : g/m^2

6.16.2 Labels

a) Material : Anodised Aluminium
 Stainless Steel

7.0 LIST OF SPARES (Bidder to furnish the lists)

a) O&M Spares list enclosed : Yes No

8.0 DOCUMENTATION

Whether following enclosed with the bid :

a) Data Sheet B. : Yes No

b) Description and design of the system and
other equipment. : Yes No

c) Two sets of descriptive pamphlets, : Yes No
giving all information regarding the
various modules/ unit components used in
the system and other equipment.

d) Compliance to Standard Quality Plan : Yes No
(enclosed in Vol II).

e) Field Quality Plan for quality checks to : Yes No
be observed at site during erection, testing
& commissioning.

f) AC power requirements of the system : Yes No

g) Block cable diagram showing the inter- : Yes No
connection between main distribution box,
master station, handset stations, loud
speakers , & JB's covering the size of cables.

h) Test certificates for equipment of similar: Yes No
design.

i) Clausewise deviations, if any. : Yes No



TECHNICAL SPECIFICATION FOR
IP BASED PUBLIC ADDRESS SYSTEM

SPECIFICATION NO. PE-TS-410-557-E001

VOLUME II B

SECTION

1X800 MW KOTHAGUDEM TPS

REVISION 0

DATE 19.10.2015

DATASHEET-C



TITLE

PUBLIC ADDRESS SYSTEM

SPECIFICATION NO. PE-TS-410-557-E001

VOLUME IIB

SECTION C

REV 0

DATE 19.10.2015

SHEET 1 OF 10

DATA SHEET - C

S.NO.	DESCRIPTION	UNIT	PARTICULARS
1.0	SYSTEM DESIGN DATA		
1.1	Design ambient temperature :	°C	
2.0	APPLICABLE STANDARDS		
2.1	Whether all standards : Specified in specification are Followed		<input type="checkbox"/> Yes <input type="checkbox"/> No
3.0	COMPLETE SYSTEM REQUIREMENTS		
a)	Frequency response :	Hz	
b)	Hum & noise level or : Signal to noise level		
4.0	SCOPE OF SYSTEM DESIGN : ENGINEERING		<input type="checkbox"/> Included <input type="checkbox"/> Excluded
5.0	POWER SUPPLY		
5.1	Whether the system suitable : For operation for power supply Details given in specification		<input type="checkbox"/> Yes <input type="checkbox"/> No
5.2	Power supply requirement at : 240V AC	kVA	
6.0	CONSTRUCTIONAL REQUIREMENTS		
6.1	AMPLIFIERS : (To be furnished Separately for each type of amplifier)	Pre- Line Loud Speaker Amplifier	Amplifier Amplifier
a)	Name of the manufacturer :		
b)	Type and manufacturers : Catalogue no.		
c)	Power supply details :		
d)	Full load consumption (VA) :		



TITLE

PUBLIC ADDRESS SYSTEM

SPECIFICATION NO. PE-TS-410-557-E001

VOLUME IIB

SECTION C

REV 0

DATE 19.10.2015

SHEET 2 OF 10

- e) Rated load/ (W/Ohm):
Output impedance
- f) Max. Ambient conditions :
- g) Output voltage (V) :
- h) Frequency response (Hz) :
- i) Total harmonic (%):
- j) Noise level (db) :
- k) Power band width (Hz):
- l) Construction :
- m) Controls provided
- i. Cont. variable : Yes No
Volume control
- ii. Standby and idle : Yes No
Time power supply
Cut-off arrangement
Arrangement
- iii. Bass & treble : Yes No
Control
- n) Sensitivity w.r.t. (mV):
Nominal output
- o) Output connections :
- p) Indications :

6.2 HANDSETS

6.2.1 Master Handset Station(s)

- a) Name of the manufacturer :
- b) Type and manufacturer's
Catalogue no. :
- c) Material :
- d) Degree of protection :
- e) Surface treatment :

	TITLE	SPECIFICATION NO. PE-TS-410-557-E001	
		VOLUME IIB	
		SECTION C	
		REV 0	DATE 19.10.2015
		SHEET 3 OF 10	
f)	Whether all features : Provided on master Handset station as per Specification requirements		<input type="checkbox"/> Yes <input type="checkbox"/> No
g)	Type of circuit : Protection		
h)	Mounting arrangement :		
i)	Dimensions (L*D*H) :	mm	
j)	Weight:	kg	
	6.2.2 HANDSETS (To be furnished Separately for each type)	Outdoor/ Indoor Wall mtd.	Indoor desk mtd.
a)	Name of the manufacturer :		
b)	Type and manufacturer's Catalogue no. :		
c)	Material :		
d)	Impedance of the Transmitter :	Ohm	
e)	Frequency response of The transmitter :		Hz
f)	Impedance of the receiver :	Ohm	
g)	Receiver output :		mV
h)	Receiver frequency Response :	Hz	
i)	Details of provision for Noise cancellation features :		
j)	Details of provision for Directional features :		
k)	Whether all features : Provided on handset station as per specification requirements		<input type="checkbox"/> Yes <input type="checkbox"/> No
l)	Degree of protection :		
m)	Surface treatment :		



TITLE

PUBLIC ADDRESS SYSTEM

SPECIFICATION NO. PE-TS-410-557-E001

VOLUME IIB

SECTION C

REV 0

DATE 19.10.2015

SHEET 4 OF 10

- n) Mounting :
- o) Dimension with control box (L*D*H) : mm
- p) Weight: kg

6.3 LOUDSPEAKERS (To be furnished separately for each type)

Reentrant Cone

- a) Name of the manufacturer :
- b) Type and manufacturer's catalogue no. :
- c) Material :
- d) Degree of protection :
- e) Surface treatment
- i. Exterior surface :
- ii. Interior surface :
- f) Impedance matching volts (Transformer details) : Ohm
- g) Output power
- i. rms : Watt
- ii. Peak : Watt
- h) Frequency response : Hz
- i) Cut-off frequency : Hz
- j) Sound level at 1000 Hz db/watt mtr. distance :
- k) Controls provided :
- l) Bell diameter : mm
- m) Acoustic length : mm
- n) Dispersion angle : Deg.
- o) Speaker diameter : mm
- p) Weight: kg



TITLE

PUBLIC ADDRESS SYSTEM

SPECIFICATION NO. PE-TS-410-557-E001

VOLUME IIB

SECTION C

REV 0

DATE 19.10.2015

SHEET 5 OF 10

6.4 MAIN DISTRIBUTION BOX

- a) Name of the manufacturer :
- b) Type :
- c) Construction :
- d) Material :
- e) Sheet steel thickness : mm
- f) Number of ways :
- g) Degree of protection :
- h) Surface treatment :
- i) Dimensions (L*D*H) : mm

6.5 JUNCTION BOX (to be furnished separately for each type)

JB-1 JB-2 JB-3

- a) Name of the manufacturer :
- b) Type :
- c) Construction :
- d) Material :
- e) Sheet steel thickness : mm
- f) Number of ways :
- g) Degree of protection :
- h) Surface treatment :
- i) Dimensions (L*D*H) : mm

6.6 COMMON REQUIREMENTS OF VARIOUS EQUIPMENTS

6.6.1 Surface Treatment

- a) If painted;
- i. Application :
- ii. Colour of paint



TITLE

PUBLIC ADDRESS SYSTEM

SPECIFICATION NO. PE-TS-410-557-E001

VOLUME IIB

SECTION C

REV 0

DATE 19.10.2015

SHEET 6 OF 10

1. Inside :

2. Outside :

iii. Minimum thickness : microns

b) If galvanized;

i. Method :

ii. Applicable Standard :

iii. Minimum thickness : microns
of zinc deposit on
all pointsiv. Weight of zinc : g/m^2

6.6.2 Labels

a) Material : Anodised Aluminium
 Stainless Steel

6.6.3 Earthing

a) Name of the manufacturer :

b) Type :

c) Size : mm

d) Details of earthing :
Arrangement

7.0 OTHER MAJOR EQUIPMENTS OF SUPPLY

7.1 CABLES (To be furnished
Separately for each type of
Cable)

7.1.1 Applicable Standard

IS: 1554 Part 1 & IS: 694 : Yes No
(In general)

7.1.2 Name of the manufacturer for

a) Power cable :

b) Signal cable :



TITLE

PUBLIC ADDRESS SYSTEM

SPECIFICATION NO. PE-TS-410-557-E001

VOLUME IIB

SECTION C

REV 0

DATE 19.10.2015

SHEET 7 OF 10

c) Loud Speaker cable :

7.1.3 Whether FRLS type cable
Provided for

- a) Power cable : Yes No
- b) Signal & loud speaker:
Cable Yes No

7.1.4 Voltage Grade for

- a) Power cable : Volts
- b) Signal & loud speaker:
Cable Volts

7.1.5 Conductor

- a) Material
- i. Power cable :
- ii. Signal & loud :
Speaker cable
- b) No. of pairs/cores,
Conductor cross sectional
Area, no. of strands and
Dia. of each strand for
- i. Power cable :
- ii. Signal cable :
- iii. Loud Speaker cable :

7.1.6 Insulation

- a) Material :
- b) Application :
- c) Volume resistivity :

7.1.7 Identification of cores/pairs

- a) Power cables:
Control cables up to
5 core &
Paired cables



TITLE

PUBLIC ADDRESS SYSTEM

SPECIFICATION NO. PE-TS-410-557-E001

VOLUME IIB

SECTION C

REV 0

DATE 19.10.2015

SHEET 8 OF 10

- b) Control cables above :
5 core

7.1.8 Paired cables

- a) Min. number of twists per :
metre for paired cables

7.1.9 Inner sheath

- a) Material : Type ST1
 Type ST2
- b) Whether FRLS : Yes No
- c) Fillers Provided :
- d) Material of filler :
- e) Method of application
- i. with fillers : Pressure Extruded
 Vacuum Extruded
- ii. without fillers :

7.1.10 Armour :

7.1.11 Outer sheath

- a) Material : Type ST1
 Type ST2

- b) Application :

- c) Colour :

7.1.12 Characteristics of FRLS sheath

- a) Oxygen index (min.) :
- b) Temp. index (min.) :
- c) Acid gas generation :
(max.)
- d) Smoke density rating :
(max.)

- 7.1.13 Progressive sequential length : Yes No
marking provided on outer



TITLE

PUBLIC ADDRESS SYSTEM

SPECIFICATION NO. PE-TS-410-557-E001

VOLUME IIB

SECTION C

REV 0

DATE 19.10.2015

SHEET 9 OF 10

sheath

7.2 CONDUITS

- a) Name of the manufacturer :
- b) Type :
- c) Gauge :
- d) Size : mm

7.3 ITEMS OF SUPPLY FOR CABLING INSTALLATION WORK

7.3.1 Cable Glands

- a) Type : Single compression
 Double compression
- b) Whether Nickel plating done : Yes No

8.0 LIST OF SPARES (Bidder to furnish the lists)

- a) Start Up Spares list enclosed : Yes No
- b) O&M Spares list enclosed : Yes No

9.0 DOCUMENTATION

Whether following documents enclosed :

- a) Full description and design of the equipment and its operation. : Yes No
- b) Dimensional and mounting details of all equipments. : Yes No
- c) General arrangement drawings for handset station (all types), loud speakers (all types), JB, Auto changeover Box, distribution box etc. : Yes No
- d) Auto changeover switching scheme. : Yes No
- e) Bill of quantities of cables, JB boxes, conduits etc. : Yes No



TITLE PUBLIC ADDRESS SYSTEM	SPECIFICATION NO. PE-TS-410-557-E001	
	VOLUME	IIB
	SECTION C	
	REV 0	DATE 19.10.2015
	SHEET 10 OF 10	

- f) Detailed write up on the method of testing. : Yes No
- g) Copies as specified in Section C of all test Certificates for the tests actually conducted on the equipment. : Yes No
- h) Final Quality Plan : Yes No
- i) Field quality plan : Yes No



TECHNICAL SPECIFICATION FOR
IP BASED PUBLIC ADDRESS SYSTEM

SPECIFICATION NO. PE-TS-410-557-E001

VOLUME II B

SECTION

1X800 MW KOTHAGUDEM TPS

REVISION
0

DATE 19.10.2015

QUALITY PLAN

Note: Quality plan attached is indicative & for reference only. Bidder shall prepare QAP in line with clause no of 17.00.00 of technical specification for IP based PA syem and submit for approval. No price implication shall be entertained for any changes in QAP during detail engineering. Bidder to quote accordingly.



QUALITY PLAN		CUSTOMER:			PROJECT TITLE: 1X800 MW KOTHAGUDEM TPS			SPECIFICATION NO : PE-TS-410-557-E-001				
SHEET 1 OF 3		BIDDER/ VENDOR :			STANDARD QP NO. : PE-QP-999-557-E001, REV. 0			SPECIFICATION TITLE:				
SYSTEM : COMMUNICATION		ITEM : PUBLIC ADDRESS SYSTEM			DOC. NO. :							
SL. NO.	COMPONENT/OPERATION	CHARACTERISTICS CHECK	CAT.	TYPE/METHOD OF CHECK	EXTENT OF CHECK	REFERENCE DOCUMENT	ACCEPTANCE NORM	FORMAT OF RECORD	AGENCY			REMARKS
									P	W	V	
1	2	3	4	5	6	7	8	9	10	11	11	
1.0	CENTRAL EXCHANGE	1. AESTHETIC	MA	VISUAL	100%	APPD. DWG.	APPD. DWG. INSP. REPT.	INSP. REPT.	3/2	1	1	BHEL witness voltage level at minimum 5 points randomly.
		2. MECHANICAL	MA	DIMENSION	100%	APPD. DWG.	APPD. DWG. INSP. REPT.	INSP. REPT.	3/2	1	1	
		3 SHEET THICKNESS	MA	DIMENSION	100%	APPD. DWG.	APPD. DWG.	INSP. REPT.	3/2	1	1	
		4. ELECTRICAL -Rated input voltage -Rated output voltage	MA	ELECTRICAL	100%	APPD. TP	APPD. TP	INSP. REPT.	3/2	1	1	
1.1	ELECTRONIC MODULE	1. Burn in test at 50 °C for 48 hours in energised condition.	MA	ELECTRICAL	100%	APPD. TP	APPD. TP	INSP. REPT.	3/2	2	1	
2.0	MASTER CONTROL STATION (MCS)	1. AESTHETIC	MA	VISUAL	100%	APPD. DWG.	APPD. DWG. INSP. REPT.	INSP. REPT.	3/2	1	1	
		2. MECHANICAL	MA	DIMENSION	100%	APPD. DWG.	APPD. DWG. INSP. REPT.	INSP. REPT.	3/2	1	1	
		3 THICKNESS	MA	DIMENSION	100%	APPD. DWG.	APPD. DWG.	INSP. REPT.	3/2	1	1	
		4. ELECTRICAL -Input impedance at 1KHz -THD at 1 KHz. -Frequency Response -Signal to Noise Ratio	MA	ELECTRICAL	100%	APPD. TP APPD. DATASHEET	APPD. TP APPD. DATASHEET	INSP. REPT.	3/2	1	1	
2.1	ELECTRONIC MODULE	1. Burn in test at 50 °C for 48 hours in energised condition.	MA	ELECTRICAL	100%	APPD. TP	APPD. TP	INSP. REPT.	3/2	2	1	
BHEL			PARTICULARS			BIDDER/VENDOR						
			NAME									
			SIGNATURE									
			DATE						BIDDER'S/VENDORS COMPANY SEAL			

LEGEND : 1 - BHEL/ CUSTOMER 2 - VENDOR 3 - SUB- VENDOR P - PERFORM W - WITNESS V - VERIFICATION



QUALITY PLAN		CUSTOMER:			PROJECT TITLE: 1X800 MW KOTHAGUDEM TPS			SPECIFICATION NO : PE-TS-410-557-E-001				
SHEET 2 OF 3		BIDDER/ VENDOR :			STANDARD QP NO. : PE-QP-999-557-E001, REV. 0			SPECIFICATION TITLE:				
SYSTEM : COMMUNICATION		ITEM : PUBLIC ADDRESS SYSTEM			DOC. NO. :							
SL. NO.	COMPONENT/OPERATION	CHARACTERISTICS CHECK	CAT.	TYPE/METHOD OF CHECK	EXTENT OF CHECK	REFERENCE DOCUMENT	ACCEPTANCE NORM	FORMAT OF RECORD	AGENCY			REMARKS
									P	W	V	
1	2	3	4	5	6	7	8	9	10			11
3.0	CONE TYPE SPEAKER, HORN LOUD SPEAKER	1. AESTHETIC	MA	VISUAL	100%	APPD. DWG.	APPD. DWG. INSP. REPT.	INSP. REPT.	3/2	1	1	BHEL witness on 5% sample (min 5) selected at random of each type per Lot.
		2. MECHANICAL	MA	DIM.	100%	APPD. DWG.	APPD. DWG. INSP. REPT.	INSP. REPT.	3/2	1	1	
		3 THICKNESS	MA	DIMENSION	100%	APPD. DWG.	APPD. DWG.	INSP. REPT.	3/2	1	1	
		4. ELECTRICAL -DC Resistance	MA	ELECTRICAL	100%	IS 9302 Part IV APPD. TP	APPD. DATA SHEET APPD. TP	INSP. REPT.	3/2	1	1	
		5. FUNCTIONAL TEST - SPL at rated output - Sweep test response	MA	ELECTRICAL	100%	IS 9302 Part IV APPD. TP	APPD. DATA SHEET APPD. TP	INSP. REPT.	3/2	1	1	
4.0	FIELD CALL STATION, PORTABLE STATION, DESKTOP STATION & FLUSH MOUNTED STATION (AS APPLICABLE)	1. AESTHETIC	MA	VISUAL	100%	APPD. DWG.	APPD. DWG. INSP. REPT.	INSP. REPT.	3/2	1	1	BHEL witness on 5% sample (min 5) selected at random of each type per Lot.
		2. MECHANICAL	MA	DIM.	100%	APPD. DWG.	APPD. DWG. INSP. REPT.	INSP. REPT.	3/2	1	1	
		3 THICKNESS	MA	DIMENSION	100%	APPD. DWG.	APPD. DWG.	INSP. REPT.	3/2	1	1	
		4. ELECTRICAL -THD at 1 KHz. -Frequency Response -Signal to Noise Ratio -Input impd. at 1 KHz	MA	ELECTRICAL	100%	APPD. DATASHEET APPD. TP	APPD. DATA SHEET APPD. TP	INSP. REPT.	3/2	1	1	
5.0	EXTENSION AMPLIFIER	1. AESTHETIC	MA	VISUAL	100%	APPD. DWG.	APPD. DWG. INSP. REPT.	INSP. REPT.	3/2	1	1	BHEL witness on 10% sample (min 3) selected at random.
		2. MECHANICAL	MA	DIMENSION	100%	APPD. DWG.	APPD. DWG. INSP. REPT.	INSP. REPT.	3/2	1	1	
		3 THICKNESS	MA	DIMENSION	100%	APPD. DWG.	APPD. DWG.	INSP. REPT.	3/2	1	1	
		4. ELECTRICAL -Input sensitivity at 1KHz -Rated output power -THD at 1 KHz -Frequency Response -Signal to Noise Ratio -Input impd. at 1 KHz -IR & HV Test	MA	ELECTRICAL	100%	IS(9302) Part II APPD. TP	APPD. DATA SHEET APPD. TP	INSP. REPT.	3/2	1	1	
BHEL			PARTICULARS			BIDDER/VENDOR						
			NAME									
			SIGNATURE									
			DATE						BIDDER'S/VENDORS COMPANY SEAL			

LEGEND : 1 - BHEL/ CUSTOMER 2 - VENDOR 3 - SUB- VENDOR P - PERFORM W - WITNESS V - VERIFICATION





QUALITY PLAN		CUSTOMER:			PROJECT TITLE: 1X800 MW KOTHAGUDEM TPS			SPECIFICATION NO : PE-TS-410-557-E-001				
SHEET 3 OF 3		BIDDER/ VENDOR :			STANDARD QP NO. : PE-QP-999-557-E001, REV. 0			SPECIFICATION TITLE:				
SYSTEM : COMMUNICATION		ITEM : PUBLIC ADDRESS SYSTEM			DOC. NO. :							
SL. NO.	COMPONENT/OPERATION	CHARACTERISTICS CHECK	CAT.	TYPE/ METHOD OF CHECK	EXTENT OF CHECK	REFERENCE DOCUMENT	ACCEPTANCE NORM	FORMAT OF RECORD	AGENCY			REMARKS
									P	W	V	
1	2	3	4	5	6	7	8	9	10			11
6.0	POWER DISTRIBUTION BOX, LOUD SPEAKER JB, POWER JB, SIGNAL JB, MAIN DISTRIBUTION FRAME (MDF), SUB DISTRIBUTION FRAME (SDF), SOCKET BOX FOR PORTABLE STATION	1. AESTHETIC 2. MECHANICAL 3 THICKNESS 4. HV / IR	MA MA MA MA	VISUAL DIM. DIMENSION ELECTRICAL	100% 100% 100% 100%	APPD. DWG. APPD. DWG. APPD. DWG. APPD. TP	APPD. DWG. APPD. DWG. APPD. DWG. APPD. DATA SHEET	INSP. REPT. INSP. REPT. INSP. REPT. INSP. REPT.	3/2 3/2 3/2 3/2	1 1 1 1	1 1 1 1	BHEL witness on 5% sample selected at random of each type per Lot.
7.0	WEATHER PROTECTING CANOPY& SOUND PROTECTING HOOD	1. AESTHETIC 2. MECHANICAL 3 THICKNESS	MA MA MA	VISUAL DIM. DIMENSION	100% 100% 100%	APPD. DWG. APPD. DWG. APPD. DWG.	APPD. DWG. APPD. DWG. APPD. DWG.	INSP. REPT. INSP. REPT. INSP. REPT.	3/2 3/2 3/2	1 1 1	1 1 1	BHEL witness on 3% sample (min 3) selected at random of each type per Lot.
8.0	INTEGRATED TESTING ON PA SYSTEM	FUNCTION -Party call -Paging call -Busy tone -Alert tone	MA	AUDIO/ VISUAL	100%	APPD. TP	APPD. TP	INSP. REPT.	2	1	1	BHEL to witness on 5 no. of stations or min 5% connected to central exchange.
9.0	TYPE TEST (As per Annexure-A)	As per Annexure A	MA	ELECTRICAL /FUNCTIONAL	SAMPLE	Reference standard as per annexure A	Reference standard as per annexure A	REPORT	3/2	1*	1	*Refer note below
NOTE: 1. CONDUCTION OF TYPE TEST/ SUBMISSION OF AVAILABLE VALID TYPE TEST REPORTS ON PA SYSTEM EQUIPMENT SHALL BE AS PER ANNEXURE A												
BHEL			PARTICULARS			BIDDER/VENDOR						
			NAME									
			SIGNATURE									
			DATE						BIDDER'S/VENDORS COMPANY SEAL			

LEGEND : 1 - BHEL/ CUSTOMER 2 - VENDOR 3 - SUB- VENDOR P - PERFORM W - WITNESS V - VERIFICATION

LIST OF TYPE TEST FOR PUBLIC ADDRESS SYSTEM

S No	Equipment	Type test description	Referred standard	Test to be specifically conducted (Yes/No)	BHEL/Customer's approval Req. on test certificate (Yes/No)
1	Central Exchange	• High frequency radiated magnetic field test	IEC 61000-4-3	No	Yes
		• Electrostatic discharge test	IEC 61000-4-2		
		• Susceptibility test	IEC 61000-4-6		
		• Vibration test	IEC 60068-2-6		
		• Dry heat & damp heat test	IEC 60068-2-2 & IEC 60068-2-30		
		• Surge protection test	IEC 61000-4-5		
2	Field call stations, Junction box, power distribution box, Central Exchange, Master Control station, Desktop station, Flush mounted station, MDF/MJB (if not integrated in central exchange)	DOP test (dust test & water test)	Relevant IS / IEC	No	Yes
3	Cone type speaker	Sound pressure level (SPL) before & after DOP test (dust test & water test)	Relevant IS / IEC	No	Yes
4	Horn type speaker	• Sound pressure level (SPL) before & after DOP test (dust test & water test)	Relevant IS / IEC	No	Yes
		• Frequency response test	IS: 9302 Part- IV		
		• Sound pressure level (SPL) test			
		• Impedance test			
		• Dry heat & damp heat test			
5	Field Call station	• Dry heat & damp heat test	IEC 60068-2-2 & IEC 60068-2-30	No	Yes
		• Vibration test	IEC 60068-2-6		
		• Electrostatic discharge test	IEC 61000-4-2		
		• Electromagnetic immunity test	As per relevant standard		
		• Surge protection test	IEC 61000-4-5		
		• RF immunity test	As per relevant standard		
6	Amplifier	• Frequency response test • Power output test • Signal to noise ratio test • Distortion test	Relevant IS / IEC	No	Yes
7	Flameproof handset station, flameproof horn type speaker, flameproof junction box (if applicable)	Type test as per relevant IS for flameproof properties	Relevant IS	No	Yes

		QUALITY PLAN SHEET 1 OF 2				CUSTOMER : TSGENCO			PROJECT 1X800 MW KOTHAGUDEM TPS			SPECIFICATION : PE-TS-410-557-E001		
						BIDDER/ VENDOR :			TITLE			NUMBER :		
SYSTEM		COMMUNICATION			QUALITY PLAN NUMBER PED-557-00-Q-002/01			SPECIFICATION TITLE			PUBLIC ADDRESS SYSTEM			
ITEM ELECTRONIC PCB ASSEMBLY		SECTION			VOLUME III			AGENCY			REMARKS			
SL. NO.	COMPONENT/OPERATION	CHARACTERISTICS CHECK	CAT.	TYPE/METHOD OF CHECK	EXTENT OF CHECK	REFERENCE DOCUMENT	ACCEPTANCE NORM	FORMAT OF RECORD	AGENCY			REMARKS		
									P	W	V			
1	2	3	4	5	6	7	8	9	10			11		
1.0	BOUGHT OUT ITEMS													
1.1	ELECTRONIC COMPONENTS ACTIVE, PASSIVE ICS, CMOS ETC.	1. MAKE/RATING	MA	VISUAL	SAMPLE	BHEL SPEC, LCSD/ BARC COMPONENT TO BE USED	BHEL SPEC, LCSD/ BARC COMPONENT TO BE USED	INSPC. REPORT	2	-	2			
1.2	POWER DIODES/THYRISTORS/ TRANSISTORS	1. MAKE/ RATING 2.ROUTINE TEST	MA MA	VISUAL ELECT. & MECH	100% 100%	BHEL SPEC./DRG. RELV. IS/ BS/ BHEL SPEC	BHEL SPEC./DRG. RELV. IS/ BS/ BHEL SPEC	-DO- -DO-	2 2	- -	1 1			
1.3	PCB CONNECTORS	1. MAKE/TYPE	MA	VISUAL	SAMPLE	BHEL SPEC, LCSD/ BARC COMPONENT TO BE USED	BHEL SPEC, LCSD/ BARC COMPONENT TO BE USED	-DO-	2	-	2			
2.0	PROCESS													
2.1	COMPONENTS MOUNTING & SOLDERING	1. CORRECTNESS OF COMPONENTS 2. MOUNTING & ORIENTATION 3. SOLDERING DEFECTS & FINISH	MA MA CR	VISUAL VISUAL VISUAL AT 10%	SAMPLE 100% 100%	MANFR. STD -DO- -DO-	MANFR. STD -DO- -DO-	-DO- -DO- -DO-	2 2 2	- - -	- - -			
BHEL			PARTICULARS			BIDDER/VENDOR								
			NAME											
			SIGNATURE											
			DATE						BIDDER'S/VENDORS COMPANY SEAL					

		QUALITY PLAN			CUSTOMER : TSGENCO			PROJECT 1X800 MW KOTHAGUDEM TPS			SPECIFICATION : PE-TS-410-557-E001		
SHEET 2 OF 2		BIDDER/ VENDOR :			TITLE QUALITY PLAN			NUMBER :			SPECIFICATION : PUBLIC ADDRESS SYSTEM		
SYSTEM		COMMUNICATION			ITEM ELECTRONIC PCB ASSEMBLY			SECTION			VOLUME III		
SL. NO.	COMPONENT/OPERATION	CHARACTERISTICS CHECK	CAT.	TYPE/METHOD OF CHECK	EXTENT OF CHECK	REFERENCE DOCUMENT	ACCEPTANCE NORM	FORMAT OF RECORD	AGENCY			REMARKS	
									P	W	V		
1	2	3	4	5	6	7	8	9	10			11	
2.2	ASSEMBLED PCBs (INTER-CONNECTED TOGETHER AS SYSTEM/ EQUIPMENT)	1. FUNCTIONAL CHECK	CR	1. ELECTRICAL BEFORE SOAKING	100%	BHEL SPEC./ MFR. STD.	BHEL SPEC./ MFR. STD.	TEST CERT	2	-	1	SOAKING AT 70°C FOR 72 HRS. AT ENERGISED CONDITION	
				2. ELECTRICAL AFTER SOAKING OR	100%	-DO-	-DO-	-DO-	2	-	1	-DO-	
				3. ELECTRICAL AFTER TEMP. CYCLE TEST	100%	-DO-	-DO-	-DO-	2	-	1	TEMP. CYCLE: RAPID TEMP. CYCLE AT+ 70°C-20°C FOR 30 MINTS. AT EACH TEMP. FIVE SUCH CYCLE	
		2. HV/ IR/ HV/ SWC	MA	ELECT. TESTS	100%	RELEVANT IS/ ANSI-C-37-90-197	-DO-	-DO-	2	1	-		
		3. UNIFORMITY & FINISH OF CONFORMAL COATING ON BOTH SIDES	CR	VISUAL	100%	BHEL SPEC./ MFR. STD	BHEL SPEC./ MFR. STD	INSPN. REPORT	2	-	-		
BHEL			PARTICULARS			BIDDER/VENDOR							
			NAME										
			SIGNATURE										
			DATE						BIDDER'S/VENDORS COMPANY SEAL				

		QUALITY PLAN			CUSTOMER : TSGENCO		PROJECT 1X800 MW KOTHAGUDEM TPS		SPECIFICATION : PE-TS-410-557-E001			
					BIDDER/ VENDOR :		TITLE TPS		NUMBER			
SHEET 1 OF 3		SYSTEM ELECTRICAL		ITEM :BOUGHT OUT ITEMS			SPECIFICATION TITLE		PUBLIC ADDRESS SYSTEM			
SL. NO.	COMPONENT/OPERATION	CHARACTERISTIC CHECK	CAT.	TYPE/METHOD OF CHECK	EXTENT OF CHECK	REFERENCE DOCUMENT	ACCEPTANCE NORM	FORMAT OF RECORD	SECTION			REMARKS
									P	W	V	
1	2	3	4	5	6	7	8	9	10			11
1.0	MATERIAL											
1.1	SECTIONS, HARDWARES, FLATS, ANGLES & CHANNEL	1. DIMENSIONS	MA	MEASUREMENT	SAMPLE	BHEL TECH. SPEC./ DRG. /DATA SHEETS/ RELEVANT. IS	BHEL TECH. SPEC./ DRG. /DATA SHEETS/ RELEVANT. IS	TEST CERT. & INSPN. REPORT	3/2	-	2	NO VISUAL DEFECT
		2. SURFACE CONDITION	MA	VISUAL	100%	-DO-	NO VISUAL DEFECTS	-DO-	3/2	-	2	TC FOR PLATING QUALITY TO BE PROVIDED
		3. SURFACE PROTECTION (HARDWARES)	MA	VISUAL	SAMPLE	-DO-	BHEL SPEC.	-DO-	3/2	-	2	
1.2	SWITCHGEAR COMPONENTS A) SWITCH, SFU'S. INSTRUMENT, TRANSF, FUSES, CONTACTORS AIR CIRCUIT BREAKERS, ISOLATORS. BIMETAL THERMAL RELAYS, MCB.S & MCCB.S	1. TYPE TESTS	MA	ELECTRICAL	EACH TYPE	BHEL SPEC./ RELEVANT IS	BHEL SPEC./ RELEVANT IS	TEST CERTIFICATE	3/2	-	2,1	
		2. ROUTINE TESTS (FOR METERS CT'S & PT'S)	MA	ELECTRICAL	100%	-DO-	-DO-	ROUTINE TEST CERTIFICATE	3/2	-	2	IF THESE ARE TAKEN FROM BHEL APPROVED SOURCE THEN TC NOT REQUIRED
		3. PHYSICAL CONDITION	MA	VISUAL	100%	NO BREAKAGES/ DAMAGES	NO. BREAKAGES/ DAMAGES	INSPN. REPORT	2	-	-	
		4. MAKE TYPE RATING ETC.	MA	VISUAL	100%	BHEL SPEC./ APPD. DRGS	BHEL SPEC./ APPD. DRGS	-DO-	2	-	-	TO BE PROCURED FROM APPROVED MAKE
		5. FUNCTIONAL TEST	MA	ELECTRICAL	100%	RELEVANT IS	RELEVANT IS	-DO-	2	-	-	
BHEL			PARTICULARS			BIDDER/VENDOR						
			NAME									
			SIGNATURE									
			DATE			BIDDER'S/VENDOR'S COMPANY SEAL						

		QUALITY PLAN	CUSTOMER : TSGENCO			PROJECT 1X800 MW KOTHAGUDEM TPS			SPECIFICATION : PE-TS-410-557-E001				
			BIDDER/ VENDOR	SYSTEM ELECTRICAL			TITLE TPS			NUMBER			
SHEET 2 OF 3		NUMBER PED-506-00-Q-002/01			QUALITY PLAN			SPECIFICATION		PUBLIC ADDRESS SYSTEM			
TITLE		ITEM :BOUGHT OUT ITEMS			SECTION			VOLUME III					
SL. NO.	COMPONENT/OPERATION	CHARACTERISTIC CHECK	CAT.	TYPE/ METHOD OF CHECK	EXTENT OF CHECK	REFERENCE DOCUMENT	ACCEPTANCE NORM	FORMAT OF RECORD	AGENCY			REMARKS	
									P	W	V		
1	2	3	4	5	6	7	8	9	10			11	
1.3	B) INSTRUMENTS, GAUGES, CONNECTORS, LUGS, GLANDS SPACE HEATER, THERMOSTAT, TERMINAL BLOCKS, LAMPS, PUSHBUTTONS, SMALL, SWITCHES, NAMEPLATES, FERRULES, LABELS, STICKERS, PVC SLEEVES/ CHANNELS	1. PHYSICAL CONDITION	MA	VISUAL	100%	NO BREAKAGES/ DAMAGES	NO BREAKAGES/ DAMAGES	INSPECTION REPORT	2	-	-	TO BE PROCURED FROM APPROVED MAKE	
		2. MAKE, TYPE, RATING ETC	MA	VISUAL	100%	BHEL SPEC./ APPD. DRGS.	BHEL SPEC./ APPD. DRGS.	-DO-	2	-	-		
		3. FUNCTIONAL	MA	ELECTRICAL	100%	RELEVANT IS	RELEVANT IS	-DO-	2	-	-		
	C) RELAYS & TIMERS	1. PHYSICAL CONDITION	MA	VISUAL	100%	NO BREAKAGES/ DAMAGES	NO BREAKAGES/ DAMAGES	INSPECTION REPORT	2	-	-		TO BE PROCURED FROM APPROVED MAKE
		2. MAKE, TYPE, RATING ETC	MA	VISUAL	100%	BHEL SPEC./ APPD. DRGS.	BHEL SPEC./ APPD. DRGS.	-DO-	2	-	-		
		3. FUNCTIONAL TEST	MA	ELECTRICAL	100%	RELEVANT IS	RELEVANT IS	-DO-	2	-	-		
	D) PCB ASSEMBLY	REFER TO QP NO.....PED-557-00-Q-002											
		INSULATING MATERIALS (FRP, SMC, DMC, ETC.)	1. ELECTRICAL	CR	ELECT. TEST	SAMPLE	BHEL SPEC./ RELEVANT IS MANUFS. STD.	BHEL SPEC./ RELEVANT IS MANUFS. STD.	TEST CERTIFICATE	2	-		1
			2. MECH. PROPS.	MA	MECH. TEST	SAMPLE	-DO-	-DO-	-DO-	2	-		1
3. TRACKING INDEX	MA		ELECT. TEST	SAMPLE	-DO-	-DO-	-DO-	3/2	-	1			
1.4	WIRES/CABLES	1. SURFACE FINISH	MA	VISUAL	100%	NO VISUAL DEFECT	NO VISUAL DEFECT	LOG BOOK/ INSP. REPORT	2	-	-		
		2. DIMENSIONS	MA	MEASUREMENT	SAMPLE	BHEL SPECN.	BHEL SPECN.	-DO-	2	-	-		
		3. HV TEST AT 80% OF ORIGINAL	CR HV	ELECT. TEST	100%	IS:694	IS:694	-DO-	2	-	-		
BHEL			PARTICULARS			BIDDER/VENDOR							
			NAME										
			SIGNATURE										
			DATE						BIDDER'S/VENDOR'S COMPANY SEAL				

		CUSTOMER : TSGENCO QUALITY PLAN BIDDER/ VENDOR			PROJECT			SPECIFICATION : PE-TS-410-557-E001					
					1X800 MW KOTHAGUDEM TPS			TITLE			NUMBER		
SHEET 3 OF 3		SYSTEM ELECTRICAL			QUALITY PLAN			PUBLIC ADDRESS SYSTEM					
					NUMBER PED-506-00-Q-002/01			TITLE					
SL. NO.		COMPONENT/OPERATION	CHARACTERISTIC CHECK	CAT.	TYPE/METHOD OF CHECK	EXTENT OF CHECK	REFERENCE DOCUMENT	ACCEPTANCE NORM	FORMAT OF RECORD	SECTION			VOLUME III
1		2	3	4	5	6	7	8	9	10			11
		P	W	V									
1.5	BUSBARS	1. DIMENSION	MA	MEASUREMENT	SAMPLE	BHEL SPEC./ APPD. DRGS.	BHEL SPEC./ APPD. DRGS.	LOG BOOK/ INSP. REPORT	2	-	-		
		2. SURFACE FINISH	MA	VISUAL	100%	-DO-	-DO-	-DO-	2	-	-		
		3. MATERIAL GRADE	MA	VERIF. OF TC	1/LOT	-DO-	-DO-	TEST. CERT.	2	-	1		
		4. CONDUCTIVITY	CR	ELECT. TEST	-DO-	-DO-	-DO-	-DO-	2	-	1		
1.6	SHEET STEEL	1. THICKNESS	MA	MEASUREMENT	SAMPLE	-DO-	-DO-	-DO-	2	-	-		
		2. WAVINESS	MA	MEASUREMENT	100%	-DO-	-DO-	-DO-	2	-	-		
		3. DUCTILITY	CR	BEND TEST	SAMPLES	-DO-	-DO-	TEST. CERT./ INSP. REPORT	2	-	-		
1.7	TRANSFORMER & REACTORS	1. ROUTINE TESTS	MA	ELECT. TEST	100%	RELEVANT STD. & BHEL SPEC.	RELEVANT STD. & BHEL SPEC.	TEST CERT.	3	-	1,2		
		2. TEMP. RISE TEST	MA	ELECT. TEST	1/RATING	-DO-	-DO-	-DO-	3	-	1,2		
1.8	PAINTS	SHELF LIFE	MA	VISUAL	100%AS PER PAINTS MANUF'S. SPEC.....		INSPN REPORT	2	-	-		
1.9	GASKETS (SYN. RUBBER ONLY)	1. DIMENSION	MA	MEASUREMENT	SAMPLE	MANUFACTURER'S DRGS.	MANUFACTURER'S DRGS.	INSPN REPORT	2	-	-		
		2. SHORE HARDNESS	MA	TEST	-DO-	MANUFACTURER'S STD.	MANUFACTURER'S STD.	INSPN REPORT	2	-	-		
		3. AGEING	MA	TEST	-DO-	IS-3400/ BS-2752	IS-3400/ BS-2752	INSPN REPORT	2	-	-		
BHEL			PARTICULAR			BIDDER / VENDOR							
			NAME										
			SIGNATURE										
			DATE						BIDDER'S/VENDOR'S COMPANY SEAL				

ANNEXURE – 1

INSTRUCTIONS FOR QUALITY PLAN

The Quality Plan shall include all the Quality Control Measures and Checks adopted by the Vendor to ensure that the material/component/assembly/services supplied by him meet/will meet the requirements as per specifications and good practices. They shall include all stages of operation such as materials, processes, manufacture, assembly, packing and despatch. The following guide lines may be noted:

- Column 1- Serial Number
- Column 2- Component/Operation- The component and/or operation being checked shall be given here.
- Column 3- Characteristics check- The characteristics being checked shall be given here, e.g., chemical composition, mechanical properties, leak tightness, surface defects etc..
- Column 4- Category -'CR' stands for critical characteristic - affecting safety of equipment and personnel
'MA' stands for major Characteristic - affecting safety of equipment and personnel
'MI' stands for minor characteristic - affecting appearance etc.
- Column 5- Type/Method of check e.g. chemical analysis tensile testing, hydraulic test, visual examination radiography etc.
- Column 6- Extent of check, such as, 100, 10, 1 percent etc.
- Column 7- Reference Documents - Documents, such as technical specification, drawings, standard specifications (IS, BS ETC.) procedure, etc. according to which check is done.
- Column 8- Acceptance Norms - Standards etc. according to which acceptability or otherwise of the characteristics being checked is decided.
- Column 9- Format of Record - Formats, log sheets, reports, etc. in which the observations are recorded. Standard log sheets, reports, formats etc. of the Vendors shall be numbered and such reference numbers shall be included here.
- Column 10- Agency - The agency which performs the test/instruction shall be written in sub-column 'W'
The agency which verifies test certificates/inspection records and carries out audit check of the components/operation shall be written in sub-column 'V'

The agencies are codified as 1,2 & 3

'1' stands for (BHEL)

'1' * means the operation shall be cleared by BHEL before the start of the next operation.

'2' Stands for Vendor

'3' stands for sub-Vendor of the Vendor and so on.

Example :

Entry '3' in column 'P' means test./inspection to be performed by sub-Vendor's QC

Entry '2' in column 'W' means test./inspection to be witnessed by Vendor's QC

Entry '1' in column 'V' means verification shall be done by BHEL and next stage to be started only after the hold point is cleared by BHEL

Column11- Remarks - Any special remarks shall be given here.

NOTES :

1. In absence of correlation with the test certificate(s) (e.g. material identification) samples shall be drawn by BHEL and all tests as per relevant specifications shall be carried out in their presence or in recognized Government Laboratory.
2. When materials and components are initially identified and stamped by BHEL QS engineer, the identification marks shall be preserved till despatch. Wherever this is not possible, the identification mark shall be transferred to the components in the presence of BHEL QS Engineer unless otherwise agreed.
3. For castings and forgings integral test specimens shall be provided, When this is not possible for casting, they shall be poured in the presence of BHEL QS Engineer unless otherwise, if witnessing of test by BHEL is called for.
4. When welders qualified by reputed inspection agencies or statutory bodies are not available, qualification tests shall be conducted in the presence of BHEL QS Engineer.
5. This Quality Plan is liable to be modified as per the requirements of approved drawings and changes in technical specifications/drawings. If there are contradictions in respect of column 7 & 8 between this Quality Plan and the approved drawings specifications, the latter shall prevail.
6. Wherever inspection by BHELs Purchaser/Third Party/Statutory authorities are mandatory, this shall be complied with.
7. Inspection reports, log sheets, test reports/certificate. etc. shall be furnished to BHEL at the appropriate stages or at the time of final inspection, as required.
8. This Quality Plan is also applicable to spares, if any, under scope of supply of Vendor.
9. **The quality plan shall be submitted in minimum 4 copies with a soft copy of the same or in line with contract requirements.**