



भारत हेवी इलेक्ट्रिकल्स लिमिटेड  
BHARAT HEAVY ELECTRICALS LIMITED

पारेषण व्यापार अभियांत्रिकी प्रबंधन

TRANSMISSION BUSINESS ENGINEERING MANAGEMENT

COPYRIGHT AND CONFIDENTIALITY The information on this document is the property of BHARAT HEAVY ELECTRICALS LTD. It must not be used directly or indirectly in anyway detrimental to the interest of the company	प्रलेख संख्या DOC. No	<b>TB-370-522-01</b>	Rev. No.	<b>00</b>		बनाया/ Prepared	जांचा/ Checked	स्वीकृती/ Approved	
	TYPE/ प्रकार OF DOC.	<b>TECHNICAL SPECIFICATION</b>			हस्ता. / SIGN				
	TITLE/ शीर्षक	<b>FIRE FIGHTING SYSTEM</b>			नाम / NAME	<b>AR</b>	<b>SKS</b>	<b>RNS</b>	
					दिनांक/ DATE	27/04/15	27/04/15	27/04/15	
					समूह/GROUP	<b>TBEM</b>	W.O. No	<b>84001</b>	
	ग्राहक/ CUSTOMER	<b>POWERGRID CORPORATION OF INDIA LTD. (POWERGRID)</b>							
	परियोजना/ PROJECT	<b>Sub Station package SS02 for (i) Extension of 400kv Bhiharsharif S/s (ii) Extension of 400kv Jamshedpur S/s (iii) Extension of 400kv Gazuwaka S/s (iv) Extension of 400kv Rengali S/s (v) Extension of 400kv Rourkela S/s (vi) Extension of 400kv Durgapur S/s (vii) Extension of 400kv Gorakhpur S/s under eastern region strenghtening scheme-IX</b>							
	प्रपत्र संख्या/ NOA NO.	<b>CC-CS/393-ER2/SS-2066/3/G6/NOA-I/4991, dated 23/06/14 CC-CS/393-ER2/SS-2066/3/G6/NOA-II/4991, dated 23/06/14</b>							
	स्थान/ STATION	<b>Bhiharsharif, Jamshedpur, Gazuwaka, Rengali, Rourkela, Durgapur and Gorakhpur</b>							
	<b>विषय-सूचि/ CONTENTS</b>								
<b>अनुभाग / Section</b>	<b>विवरण / Description</b>								
1	Intent, Design criteria, System requirement and scope								
2	Equipment Specification (Customer specification)								
3	Project details and general specification								
4	Guaranteed Technical Particulars								
5	Schedule to be filled by Bidder								
	Rev No.	Date	Altered	Checked	Approved	REVISION DETAILS			
	Distribution				To	TBEM	TBMM	TBQM	Vendor
					Copies	1	1	1	4

<b>Project</b>	<b>Sub Station package SS02 for (i) Extension of 400kv Bihharsharif S/s (ii) Extension of 400kv Jamshedpur S/s (iii) Extension of 400kv Gazuwaka S/s (iv) Extension of 400kv Rengali S/s (v) Extension of 400kv Rourkela S/s (vi) Extension of 400kv Durgapur S/s (vii) Extension of 400kv Gorakhpur S/s under eastern region strengthening scheme-IX</b>	<b>TB-370-522-01 Rev 00</b>	
<b>System</b>	<b>FIRE FIGHTING SYSTEM</b>		
<b>Owner</b>	<b>POWERGRID CORPORATION OF INDIA LTD.</b>		
<b>Purchaser</b>	<b>BHARAT HEAVY ELECTRICALS LTD (Transmission Business Group)</b>		

**SECTION 1**  
**INTENT, SYSTEM REQUIREMENT, DESIGN CRITERIA AND SCOPE**

**1.0.0 INTENT OF SPECIFICATION**

- 1.1.0 This specification is intended to specify the requirements for design, engineering, manufacture, assembly, stage testing, inspection, testing before supply, packing, forwarding, transportation at site, complete erection of all equipment and accessories, testing of the system, trial run, commissioning of the system, final painting and carrying out acceptance test of Fire Fighting System along with its accessories and auxiliary equipments / instruments etc. as mentioned in this section and in various other sections of this specification for 400kV Bay extension at Biharsharif, Jamshedpur, Gazuwaka, Rengali, Rourkela and Durgapur, Substation of **Power Grid Corporation of India Limited (POWERGRID)**.
- 1.2.0 The system shall be designed, erected & commissioned in accordance with **TAC/ NFPA** guidelines.
- 1.3.0 Requirements pertaining to type, make, quality, testing & inspection of equipments as laid down in various clauses of CUSTOMER (Powergrid) Specification, enclosed in Section 2, shall be full & final. In the event of any contradiction w.r.t. other sections of this specification, technical requirements of Section 1 & 2 shall prevail.
- 1.4.0 The Bidder shall be deemed to have understood completely all the tender drawings and documents and quoted accordingly.
- 1.5.0 It is not the intent to specify herein all the details of design and manufacture. However, the equipment shall conform in all respect to high standards of design, engineering and workmanship and shall be capable of performing the required duties in a manner acceptable to Purchaser / Owner, who will interpret the meaning of drawings and specifications and shall be entitled to reject any work or material, which in his/their judgment is not in full accordance with the specifications
- 1.6.0 The Bidder to note carefully that parameters, estimated capacities of equipment indicated and the tender drawings in the specification are only for the guidance of the Bidder. The system shall be designed as per relevant standards/ codes and exact capacities and quantities are to be estimated by the Bidder. All such estimations and design calculations shall be submitted for Purchaser's approval.
- 1.7.0 **The contract shall be on lump-sum basis for the package. Within the scope of the contract, no variation shall be admissible to the contractor so far the input remains unchanged. In case of variations due to unforeseen changes in scope during contract stage, the additions/ deletions to the scope shall be settled on the basis of mutually agreed rates**
- 1.8.0 The term ‘Owner’ appearing in this specification shall refer to **Powergrid**, the term ‘Purchaser’ shall refer to **BHEL** and the term ‘Contractor’ shall refer to the **successful Bidder**.

<b>Project</b>	<b>Sub Station package SS02 for (i) Extension of 400kv Bihharsharif S/s (ii) Extension of 400kv Jamshedpur S/s (iii) Extension of 400kv Gazuwaka S/s (iv) Extension of 400kv Rengali S/s (v) Extension of 400kv Rourkela S/s (vi) Extension of 400kv Durgapur S/s (vii) Extension of 400kv Gorakhpur S/s under eastern region strengthening scheme-IX</b>	<b>TB-370-522-01 Rev 00</b>	
<b>System</b>	<b>FIRE FIGHTING SYSTEM</b>		
<b>Owner</b>	<b>POWERGRID CORPORATION OF INDIA LTD.</b>		
<b>Purchaser</b>	<b>BHARAT HEAVY ELECTRICALS LTD (Transmission Business Group)</b>		

- 1.9.0 There shall preferably be no deviation on technical specification. The bidder shall sign and stamp the “Certificate for No Deviation” enclosed in Schedule-3, Section-5 towards confirmation. *Deviations in any other form including clarifications / assumptions / observations, input data in the GTP etc will not be considered and it will be construed that the bid conforms strictly to the specification.*

## 2.0 TYPE OF FIRE PROTECTION REQUIRED

### A. Biharsharif S/s

- i) Hydrant system for *01No. 125 MVAR Reactor,*
- ii) HVW spray system for *01 No. 125 MVAR Reactor*

*(OGA of 125MVAR-BHEL Make Reactor is enclosed for reference and estimation purpose only)*

One 125MVAR Bus Reactor would be installed in parallel with existing 50MVAR Bus Reactor. The existing piping (for fire protection system near 50MVAR Bus Reactor in parallel with the 125MVAR Bus reactor under present scope) shall be further extended for this purpose. However both the fire fighting system shall operate independently for the reactor.

(Location of 125 MVAR Reactor, pump house and control room building are shown in the cable trench layout & attached to this spec.). Fire alarm cum Annunciation panel of current scope shall be kept in the existing control room building and annunciation panel in existing Pump house as per Powergrid standard scheme.

\*Tap-off point for HVW spray and hydrant system for reactor shall be considered of suitable size as per Powergrid standard P&I drawing. It may be taken as approximately 50 meter for Biharsharif S/s for tender purpose.

**B. Jamshedpur S/s:** One no.420kV, 125MVAR Bus Reactor#3 in parallel with the existing 420kV, 50MVAR (3x16.67MVAR) Bus Reactor#1 and One No. 420kV, 125MVAR Bus Reactor#2 replacing existing 50MVAR (3x16.67MVAR) Bus Reactor

- i) Hydrant system for *02Nos. 125 MVAR Reactors,*
- ii) HVW spray system for *02 Nos. 125 MVAR Reactors*

*(OGA of 125MVAR-BHEL Make Reactor is enclosed for reference and estimation purpose only)*

The existing adjacent piping (for fire protection system of existing 50MVAR Bus Reactor-1&2) shall further be extended for this purpose. Existing fire protection system of existing Bus Reactor-2 along with deluge valve is to be dismantled (under BHEL scope).

(Location of 125 MVAR Reactor, pump house and control room building are shown in the cable trench layout & attached to this spec.). Fire alarm cum Annunciation panel of current scope shall be kept in the existing control room building and annunciation panel in existing Pump house as per Powergrid standard scheme.

<b>Project</b>	<b>Sub Station package SS02 for (i) Extension of 400kv Bhiharsharif S/s (ii) Extension of 400kv Jamshedpur S/s (iii) Extension of 400kv Gazuwaka S/s (iv) Extension of 400kv Rengali S/s (v) Extension of 400kv Rourkela S/s (vi) Extension of 400kv Durgapur S/s (vii) Extension of 400kv Gorakhpur S/s under eastern region strengthening scheme- IX</b>	<b>TB-370-522-01 Rev 00</b>	
<b>System</b>	<b>FIRE FIGHTING SYSTEM</b>		
<b>Owner</b>	<b>POWERGRID CORPORATION OF INDIA LTD.</b>		
<b>Purchaser</b>	<b>BHARAT HEAVY ELECTRICALS LTD (Transmission Business Group)</b>		

\*Tap-off point for HVW spray and hydrant system for reactors shall be considered of suitable size as per Powergrid standard P&I drawing. It may be taken as approximately 75 meter for Jamshedpur S/s for tender purpose.

### **C. Gazuwaka S/s**

- i) Hydrant system for **01No. 125 MVAR Reactor,**
- ii) HVW spray system for **01 No. 125 MVAR Reactor**

*(OGA of 125MVAR-BHEL Make Reactor is enclosed for reference and estimation purpose only)*

The existing piping (for fire protection system of line Reactor of Jeypore-I line bay) shall further be extended for this purpose.

(Location of 125 MVAR Reactor, pump house and control room building are shown in the cable trench layout & attached to this spec.). Fire alarm cum Annunciation panel of respective substations shall be kept in the existing control room building and annunciation panel in existing Pump house as per Powergrid standard scheme.

\*Tap-off point for HVW spray and hydrant system for reactor shall be considered of suitable size as per Powergrid standard P&I drawing. It may be taken as approximately 500 meter for Gazuwaka S/s for tender purpose.

### **D. Rengali S/s:**

- i) Hydrant system for **02Nos. 125 MVAR Reactors,**
- ii) HVW spray system for **02 Nos. 125 MVAR Reactors**

*(OGA of 125MVAR-BHEL Make Reactor is enclosed for reference and estimation purpose only)*

The existing piping (for fire protection system of 63MVAR line reactor of Indravati line bay) shall be further extended for this purpose.

(Location of 125 MVAR Reactor, pump house and control room building are shown in the cable trench layout & attached to this spec.). Fire alarm cum Annunciation panel of current scope shall be kept in the existing control room building and annunciation panel in existing Pump house as per Powergrid standard scheme.

\*Tap-off point for HVW spray and hydrant system for reactor shall be considered of suitable size as per Powergrid standard P&I drawing. It may be taken as approximately 450 meter for Rengali S/s for tender purpose.

**E. Rourkela S/s:** 1 no. 420kV, 125MVAR Bus Reactor replacing the existing 50MVAR (3x16.67MVAR) Bus Reactor.

- i) Hydrant system for **01No. 125 MVAR Reactor,**
- ii) HVW spray system for **01 No. 125 MVAR Reactor**

The existing piping (for fire protection system of existing 50MVAR Reactor to be replaced with 125MVAR) shall further be extended for this purpose.

<b>Project</b>	<b>Sub Station package SS02 for (i) Extension of 400kv Bhiharsharif S/s (ii) Extension of 400kv Jamshedpur S/s (iii) Extension of 400kv Gazuwaka S/s (iv) Extension of 400kv Rengali S/s (v) Extension of 400kv Rourkela S/s (vi) Extension of 400kv Durgapur S/s (vii) Extension of 400kv Gorakhpur S/s under eastern region strengthening scheme-IX</b>	<b>TB-370-522-01 Rev 00</b>	
<b>System</b>	<b>FIRE FIGHTING SYSTEM</b>		
<b>Owner</b>	<b>POWERGRID CORPORATION OF INDIA LTD.</b>		
<b>Purchaser</b>	<b>BHARAT HEAVY ELECTRICALS LTD (Transmission Business Group)</b>		

Existing HVW spray system including deluge valve of 420kV, 50MVAR Bus Reactor shall be dismantled (under BHEL scope).

\*Tap-off point for HVW spray and hydrant system for reactor shall be considered of suitable size as per Powergrid standard P&I drawing. It may be taken as approximately 20 meter for Rourkela S/s for tender purpose.

#### **F. Durgapur S/s:**

- i) Hydrant system for *02Nos. 125 MVAR Reactors,*
- ii) HVW spray system for *02 Nos. 125 MVAR Reactors*

*(OGA of 125MVAR-BHEL Make Reactor is enclosed for reference and estimation purpose only)*

The existing adjacent piping for fire protection system of existing 50MVAR Bus Reactor with Jamshedpur line diameter and existing 315MVA ICT#2 shall further be extended for this purpose.

(Location of 125 MVAR Reactor, pump house and control room building are shown in the cable trench layout & attached to this spec.). Fire alarm cum Annunciation panel of current scope shall be kept in the existing control room building and annunciation panel in existing Pump house as per Powergrid standard scheme.

\*Tap-off point for HVW spray and hydrant system for reactor shall be considered of suitable size as per Powergrid standard P&I drawing. It may be taken as approximately 550 meter for Durgapur S/s for tender purpose.

### **3. DESIGN CRITERIA**

- 3.1 The equipment offered shall comply with the relevant Indian Standards. The equipment conforming to any other approved international standards shall meet the requirement called for in the latest revision of relevant Indian Standard or shall be superior. The Deluge valves, HVW spray nozzles & quartzoid bulb detectors shall have the approval of any of the following agencies;
  - a. UL of USA.
  - b. F M ofUSA
  - c. LPCB of UK or
  - d. VDS of Germany,
- 3.2 Light Hazard occupancy shall be considered for hydrant protection.
- 3.3 All the requirements regarding supplies, provisions of control, interlocks, indications, annunciations, alarms etc. stipulated in various clauses of Powergrid specification (Section2) shall be satisfied by the contractor in totality.
- 3.4 It is contractor's responsibility to prepare the standard HVW spray drawing of 125MVAR reactor (BHEL make) and get approval on the same from Powergrid.

<b>Project</b>	Sub Station package SS02 for (i) Extension of 400kv Bihharsharif S/s (ii) Extension of 400kv Jamshedpur S/s (iii) Extension of 400kv Gazuwaka S/s (iv) Extension of 400kv Rengali S/s (v) Extension of 400kv Rourkela S/s (vi) Extension of 400kv Durgapur S/s (vii) Extension of 400kv Gorakhpur S/s under eastern region strengthening scheme-IX	TB-370-522-01 Rev 00	
<b>System</b>	FIRE FIGHTING SYSTEM		
<b>Owner</b>	POWERGRID CORPORATION OF INDIA LTD.		
<b>Purchaser</b>	BHARAT HEAVY ELECTRICALS LTD (Transmission Business Group)		

### 3.5 Interfacing Requirement

Provision of sufficient potential free contacts in FAP to repeat all the fire fighting system alarms in SAS (Substation automation system) as per Powergrid standard specification attached in sec-2.

## 4. SCOPE OF SUPPLIES & SERVICES

The requirements mentioned under this clause are *indicative and minimum* for the system. Any other item/ service required to complete the work for safe and sound operation of system (as under customer technical specification enclosed under section-2) shall be provided and installed by the bidder at no extra cost to the purchaser. The bidder may bring out such requirement(s) suitably.

### 4.1.0 SCOPE OF SUPPLY

A) Complete supply for 400kVBay Biharsharif S/s Extn consists of following heads:

Sr. No.	System	Areas Covered	QTY
1	Hydrant System	01 No. of 125 MVAR Reactor	1 Lot
2	HVW Spray System	01 No. of 125 MVAR, 400 kV Bus Reactor, 3- phase	1 Lot
3	Electrical panels	Control and annunciation panels as per Powergrid specification	1 Lot

B) Complete supply for 400kVBay Jamshedpur S/s Extn consists of following heads:

Sr. No.	System	Areas Covered	QTY
1	Hydrant System	02 Nos. of 125 MVAR Reactor	1 Lot
2	HVW Spray System	02 Nos. of 125 MVAR, 400 kV Bus Reactor, 3- phase	1 Lot
3	Electrical panels	Control and annunciation panels as per Powergrid specification	1 Lot

C) Complete supply for 400kVBay Gazuwaka S/s Extn consists of following heads:

Sr. No.	System	Areas Covered	QTY
1	Hydrant System	01 No. of 125 MVAR Reactor	1 Lot
2	HVW Spray System	01 No. of 125 MVAR, 400 kV Bus Reactor, 3- phase	1 Lot

**Project** Sub Station package SS02 for (i) Extension of 400kv Bhiharsharif S/s (ii) Extension of 400kv Jamshedpur S/s (iii) Extension of 400kv Gazuwaka S/s (iv) Extension of 400kv Rengali S/s (v) Extension of 400kv Rourkela S/s (vi) Extension of 400kv Durgapur S/s (vii) Extension of 400kv Gorakhpur S/s under eastern region strengthening scheme- IX

**TB-370-522-01**  
**Rev 00**



**System** FIRE FIGHTING SYSTEM  
**Owner** POWERGRID CORPORATION OF INDIA LTD.  
**Purchaser** BHARAT HEAVY ELECTRICALS LTD  
(Transmission Business Group)

3	Electrical panels	Control and annunciation panels as per Powergrid specification	1 Lot
---	-------------------	--	-------

**D) Complete supply for 400kVBay Rengali S/s Extn consists of following heads:**

Sr. No.	System	Areas Covered	QTY
1	Hydrant System	02 Nos. of 125 MVAR Reactor	1 Lot
2	HVW Spray System	02 Nos. of 125 MVAR, 400 kV Bus Reactor, 3- phase	1 Lot
3	Electrical panels	Control and annunciation panels as per Powergrid specification	1 Lot

**E) Complete supply for 400kVBay Rourkela S/s Extn consists of following heads:**

Sr. No.	System	Areas Covered	QTY
1	Hydrant System	01 No. of 125 MVAR Reactor	1 Lot
2	HVW Spray System	01 No. of 125 MVAR, 400 kV Bus Reactor, 3- phase	1 Lot
3	Electrical panels	Control and annunciation panels as per Powergrid specification	1 Lot

**F) Complete supply for 400kVBay Durgapur S/s Extn consists of following heads:**

Sr. No.	System	Areas Covered	QTY
1	Hydrant System	02 Nos. of 125 MVAR Reactor	1 Lot
2	HVW Spray System	02 Nos. of 125 MVAR, 400 kV Bus Reactor, 3- phase	1 Lot
3	Electrical panels	Control and annunciation panels as per Powergrid specification	1 Lot

Besides, the Bidder shall take a note of the following while preparing his offer:

- a. Power & Control cables for fire protection system (except for Detection & alarm system) will be supplied on free issue basis to contractor. BHEL shall procure various sizes of cables (as per Annexure 'A' of this section) for the complete requirement of sub-station. Contractor shall have to

<b>Project</b>	<b>Sub Station package SS02 for (i) Extension of 400kv Bihharsharif S/s (ii) Extension of 400kv Jamshedpur S/s (iii) Extension of 400kv Gazuwaka S/s (iv) Extension of 400kv Rengali S/s (v) Extension of 400kv Rourkela S/s (vi) Extension of 400kv Durgapur S/s (vii) Extension of 400kv Gorakhpur S/s under eastern region strengthening scheme-IX</b>	<b>TB-370-522-01 Rev 00</b>	
<b>System</b>	<b>FIRE FIGHTING SYSTEM</b>		
<b>Owner</b>	<b>POWERGRID CORPORATION OF INDIA LTD.</b>		
<b>Purchaser</b>	<b>BHARAT HEAVY ELECTRICALS LTD (Transmission Business Group)</b>		

choose their cables from the available sizes only and necessary modifications in their equipment for termination of these cables shall be made by contractor.

- b. Since laying & termination of all power & control cables is in contractor's scope, supply of cable accessories such as lugs, glands, cable tags & markers etc. shall be included by the bidders in their offers alongwith supply of cable for fire detection and alarm system. Cables for detection and alarm system, if applicable, shall be as per Cl. 2.03.04 of POWERGRID specification attached under section-2.
- c. Necessary cable trays will be supplied on free issue basis to the contractor, however necessary hardware for fixing the same on walls or elsewhere shall be included by the bidders in their offers.
- d. Earthing material viz. GS flat & wire will also be supplied on free issue basis to contractor, however requirement shall be given by the bidders in their respective bids.
- e. Pipe structure for pylon support around reactor shall be fixed to the bottom of sump with the help of Anchor fastners. The structure will be in two pieces with a flanged joint at around Zero level above chequered plate. Pipe size for pylon, size of Anchor fasteners etc. shall be adequate for the support to provide sufficient rigidity against vibration & load during operation. The whole arrangement shall be in bidder's scope. The contractor shall justify adequacy of design during engineering.
- f. Contractor shall submit valid Type test report for approval by owner. Fresh type test of equipment is not envisaged. It is presumed that equipments offered are duly type tested.

Type Test Certificate for degree of protection shall be submitted for the following:

1. Deluge Valve local control panel
2. Any Annunciation/Control panel as per Powergrid scheme

In case the type test reports are found un-satisfactory, tests shall be carried out afresh by contractor without any additional cost implication to BHEL and getting approval from Powergrid on the fresh type test report shall be of contractor's responsibility.

- g. Bidder shall choose the makes from Powergrid's "compendium of approved vendors", which is available on the internet. In case, no vendor is specified in compendium against a particular item, only reputed makes available in the market shall be considered. All such makes shall be subjected to acceptance of Powergrid. No additional price implication shall be made to BHEL on account of non-acceptance of proposed makes by Powergrid.
- h. All the components except for reactor as appearing in the enclosed P&I diagram are in contractor's scope of supply & ETC.
- i. **While making his Bid, Bidder should check the requirements carefully for 400kV & 220kV sub-stations, which are clearly demarcated in Section-2.**
- j. Any spares required for commissioning purpose shall be supplied separately by the contractor.

<b>Project</b>	<b>Sub Station package SS02 for (i) Extension of 400kv Bhiharsharif S/s (ii) Extension of 400kv Jamshedpur S/s (iii) Extension of 400kv Gazuwaka S/s (iv) Extension of 400kv Rengali S/s (v) Extension of 400kv Rourkela S/s (vi) Extension of 400kv Durgapur S/s (vii) Extension of 400kv Gorakhpur S/s under eastern region strengthening scheme-IX</b>	<b>TB-370-522-01 Rev 00</b>	
<b>System</b>	<b>FIRE FIGHTING SYSTEM</b>		
<b>Owner</b>	<b>POWERGRID CORPORATION OF INDIA LTD.</b>		
<b>Purchaser</b>	<b>BHARAT HEAVY ELECTRICALS LTD (Transmission Business Group)</b>		

#### **4.2.0 SCOPE OF SERVICES**

##### **4.2.1 Erection, Testing & Commissioning (ETC) requirements**

- a) The scope of ETC shall include handling of equipment/ material at site, erection of equipment /material at site including fabrication, equipment and system testing, commissioning of the entire system at all sites.
- b) Erection of pipe pylon supports, with pipe hangers and other pipe supports corresponding to HVW Spray system.
- c) Painting of aboveground piping (for hydrant system & HVW spray system in the switchyard), pipe pylon supports etc. as per customer specification.
- d) Land excavation, laying of underground piping for hydrant/ spray system with wrapping & coating & backfilling.
- e) Laying and termination of power and control cables for the equipment under the scope this specification.
- f) Laying & fixing of cable trays on walls or elsewhere, if applicable.
- g) All the installations in the switchyard and pump house shall be properly earthed by the contractor to the nearest earthmat riser of the Owner / Purchaser.
- h) The contractor shall arrange all machinery -tools & tackles and consumables required for erection of the system.
- i) Contractor shall ensure that sufficient quantity of commissioning spares is made available for timely completion of commissioning of the system. The contractor shall furnish a list of commissioning spares that will be brought by him. The unused commissioning spares shall be returnable to the Contractor.
- j) Conducting Performance Guarantee tests to the satisfaction of Owner / Purchaser.
- k) It is the responsibility of the successful Bidder to obtain necessary approval/ clearance from statutory organizations wherever applicable for the equipment/ systems under the scope specified.
- l) After completion of erection and commissioning of the system, the contractor shall train site engineers of Purchaser/Owner so that they are fully conversant with both electrical and mechanical part of the package.
- m) The contractor shall furnish the operation and maintenance manual specifically compiled for each of the sub-stations. The draft O&M manual shall be submitted within 20 weeks after award of contract. The O&M manual shall contain the following information:
  - i) Description of the system and equipment with design particulars
  - ii) Instruction for erection.
  - iii) Instruction for operation, maintenance and repair.
  - iv) Recommended inspection practices and inspection schedule.
  - v) Ordering information for all replaceable parts
  - vi) Recommendation for type of lubricants and frequency of lubrication.

<b>Project</b>	<b>Sub Station package SS02 for (i) Extension of 400kv Bihharsharif S/s (ii) Extension of 400kv Jamshedpur S/s (iii) Extension of 400kv Gazuwaka S/s (iv) Extension of 400kv Rengali S/s (v) Extension of 400kv Rourkela S/s (vi) Extension of 400kv Durgapur S/s (vii) Extension of 400kv Gorakhpur S/s under eastern region strengthening scheme- IX</b>	<b>TB-370-522-01 Rev 00</b>	
<b>System</b>	<b>FIRE FIGHTING SYSTEM</b>		
<b>Owner</b>	<b>POWERGRID CORPORATION OF INDIA LTD.</b>		
<b>Purchaser</b>	<b>BHARAT HEAVY ELECTRICALS LTD (Transmission Business Group)</b>		

#### 4.2.2 Civil Works

Minor civil works such as grouting, filling up of crevices/ cut outs etc during installation of equipment shall also be in contractor's scope. Any other damage caused to civil works during ETC work of the equipment/system shall be made good to the original finish by the Contractor at no extra cost to the Purchaser.

#### 4.2.3 Inspection & Testing

All the equipments shall be inspected prior to dispatch in line with relevant IS, approved GTP/ drawing and technical specification.

### 5. EXCLUSIONS

- Supply of power & control cables for the system except for fire detection & alarm system which shall be supplied by contractor.
- Supply of necessary cable trays for laying power and control cables, wherever required.
- Supply of GI flat for earthing of equipments.
- Construction of RCC pedestals to support the above ground piping for hydrant & spray system and for pylon supports of HVW spray system outside sump pit, wherever required.
- Construction of housing for deluge valve and painting the same on outside & inside. The housing shall have RCC roof.
- Unloading and storage of material at site.

### 6. HANDING & TAKING OVER

It is the responsibility of the Contractor to run and maintain the plant till it is handed over to the owner. Contractor shall assist purchaser to hand over the plant to owner.

### 7. UTILITIES AVAILABLE

Construction water and 415 V power shall be available at one point each. Contractor shall be required to make own arrangement for taking supplies from there.

#### ANNEXURE- 'A'

#### Cable Sizes being procured by BHEL for Sub-Station

Sl. No.	Item Description	Length (Mtrs)	Remark
<b>1.0</b>	<b>Power Cables (PVC) (1100 V Grade)</b>		
A	3.5C x 70 sq mm PVC/ Al. Aux Power Cable		
B	4C x 6 sq mm PVC/ Al. Aux Power Cable		
<b>2.0</b>	<b>Control Cables (Cu)</b>		

**Project** Sub Station package SS02 for (i) Extension of 400kv Bihharsharif S/s (ii) Extension of 400kv Jamshedpur S/s (iii) Extension of 400kv Gazuwaka S/s (iv) Extension of 400kv Rengali S/s (v) Extension of 400kv Rourkela S/s (vi) Extension of 400kv Durgapur S/s (vii) Extension of 400kv Gorakhpur S/s under eastern region strengthening scheme-IX

**TB-370-522-01**  
**Rev 00**



**System** FIRE FIGHTING SYSTEM  
**Owner** POWERGRID CORPORATION OF INDIA LTD.  
**Purchaser** BHARAT HEAVY ELECTRICALS LTD  
(Transmission Business Group)

A	2C x 2.5 sq mm PVC/Cu. Control Cable		
B	5C x 2.5 sq mm PVC/ Cu. Control Cable		
C	7C x 2.5 sq mm PVC/ Cu. Control Cable		
D	10C x 2.5 sq mm PVC/ Cu. Control Cable		
E	14C x 2.5 sq mm PVC/ Cu. Control Cable		
F	19C x 2.5 sq mm PVC/ Cu. Control Cable		

<b>Project</b>	<b>Sub Station package SS02 for (i) Extension of 400kv Bhiharsharif S/s (ii) Extension of 400kv Jamshedpur S/s (iii) Extension of 400kv Gazuwaka S/s (iv) Extension of 400kv Rengali S/s (v) Extension of 400kv Rourkela S/s (vi) Extension of 400kv Durgapur S/s (vii) Extension of 400kv Gorakhpur S/s under eastern region strengthening scheme-IX</b>	<b>TB-370-522-01 Rev 00</b>	
<b>System</b>	<b>FIRE FIGHTING SYSTEM</b>		
<b>Owner</b>	<b>POWERGRID CORPORATION OF INDIA LTD.</b>		
<b>Purchaser</b>	<b>BHARAT HEAVY ELECTRICALS LTD (Transmission Business Group)</b>		

**SECTION 2  
EQUIPMENT SPECIFICATION**

Refer the enclosed specifications (Doc ref: C/ENGG/SPEC/FP Rev-6) for Fire Protection System.

All the requirements pertaining to type, make, quality, testing & inspection of equipments, provisions of control, interlocks, indications, annunciators, alarms etc, as laid down in various clauses of this specification shall be satisfied by the contractor in totality.

**TECHNICAL SPECIFICATION FOR**  
**FIRE PROTECTION SYSTEM**  
**TABLE OF CONTENTS**

<u>Clause No.</u>	<u>Description</u>	<u>Page No.</u>
1.00.00	Intent of Specification	1
2.00.00	Design and construction	2
3.00.00	Tests	14
4.00.00	Spare Parts	16
5.00.00	Horizontal Centrifugal Pumps	16
6.00.00	Diesel Engines	22
7.00.00	Piping, Valves & Specialities	26
8.00.00	Air Vessels	34
9.00.00	Heat detectors/Fire detectors and spray nozzles	35
10.00.00	Portable and Wheel/ Trolley mounted Fire Extinguishers	36
11.00.00	Instruments	38
12.00.00	Electric Motors	41
13.00.00	Battery & Battery chargers	47
14.00.00	Control and Annunciation Panels	49
Appendix-I	P&I for Hydrant & HVW Spray System for 765kV and 400kV Substation	
Appendix-II	Typical Drawings for location of Fire Detectors and Extinguishers	
Appendix-III	Typical Drawings of HVW Spray System for transformer & reactor	
Appendix-IV	Technical Data Sheets	
Appendix-V	List of Approved Vendors	
Appendix-VI	P&I for Hydrant & HVW Spray System for 220kV and 132kV Substation	

**TECHNICAL SPECIFICATION FOR**  
**FIRE PROTECTION SYSTEM**

**1.00.00 INTENT OF SPECIFICATION**

This section covers the design and performance requirements of the following types of fire protection systems;

- a. Hydrant System
- b. High Velocity Water (H.V.W) Spray System
- c. Fire Detection and alarm System
- d. Portable Fire Extinguishers
- e. Wheel/ Trolley mounted Fire Extinguishers

1.00.01 It is not the intent to completely specify all details of design and construction. Nevertheless, the system design and equipment shall conform in all respects to high standard of engineering, design and workmanship and shall be capable of performing in continuous commercial operation in a manner acceptable to the Owner. The system design shall also conform to TAC/ NFPA norms.

1.00.02 The scope of work include complete earthwork (i.e. excavation, backfilling etc.) for the entire buried piping for the system, valve pits and pipe supports for buried, entrenched and overground piping.

1.00.03 **The equipment offered shall comply with the relevant Indian Standards unless specified otherwise.** The equipment conforming to any other approved international standards shall meet the requirement called for in the latest revision of relevant Indian Standard or shall be superior. The Deluge valves, HVW spray nozzles & quartzoid bulb detectors shall have the approval of any of the following agencies;

- a. UL of USA.
- b. F M of USA
- c. LPCB of UK or
- d. VDS of Germany,

1.00.04 Ambient temperature for design of all equipment shall be considered as 50°C.

1.00.05 **The piping and instruments diagram for Hydrant and HVW spray system for 765kV/400kV substations and for 220kV&132kV substation is**

enclosed at Appendix-I and Appendix-VI respectively. The successful bidder shall prepare detailed layout and piping drawing based on this drawing and other drawings such as road, drainage, cable trench, switch yard layout, etc. as furnished by the Employer during detailed engineering.

The typical drawings for location of fire detectors and fire extinguishers in control cum administrative building attached in Appendix-II with this section shall be followed for execution.

- 1.00.06 Equipment under the fire protection system should be supplied from the suppliers approved by POWERGRID (A list of approved vendors is enclosed at Appendix-V). All equipment shall conform to the data sheets attached in Appendix-IV and/or relevant subsections/clauses of this specification. In case of contradiction between data specification sheets and relevant subsections/clauses, then stipulations of the data sheets will prevail.

## 2.00.00 DESIGN AND CONSTRUCTION

### 2.01.00 Hydrant System

Hydrant system of fire protection essentially consists of a large network of pipe, both under ground and over ground which feeds pressurised water to a number of hydrant valves, indoor (if applicable) as well as outdoor. These hydrant valves are located at strategic locations near buildings, Transformers and Reactors. Hose pipes of suitable length and fitted with standard accessories like branch pipes, nozzles etc., are kept in Hose boxes. In case of emergency, these hoses are coupled to the respective hydrant valves through instantaneous couplings and jet of water is directed on the equipment on fire. Hydrant protection shall be provided for the following in all substations of voltage levels 132kV and above (This is not applicable for extension of existing 220kV and 132kV substations where Hydrant system is not available). At least one hydrant post shall be provided for every 60m of external wall measurement of buildings.

- a) Control room building
- b) L.T. Transformer area.
- c) Fire Fighting pump House.
- d) Stores
- e) Transformers

f) Shunt Reactors/ Bus Reactors.

2.01.01 A warning plate shall be placed near the hydrant points for the transformers and reactors substations to clearly indicate that water shall be sprayed only after ensuring that the power to the transformer/ reactor which is on fire is switched off and there are no live parts within 20metres of distance from the personnel using the hydrant.

2.02.00. **HIGH VELOCITY WATER (H.V.W) SPRAY SYSTEM**

H.V.W. spray type fire protection essentially consists of a network of projectors and an array of heat detectors around the Transformer/Reactor to be protected. On operation of one or more of heat detectors, Water under pressure is directed to the projector network through a Deluge valve from the pipe network laid for this system. **This shall be provided for transformers and reactors in all 132kV & above substations (This is not applicable for extension of existing 220kV and 132kV substations where HVWS system is not available).** Wet detection initiation system shall be employed for automatic operation.

The system shall be designed in such a way that the same can be extended to protect additional Transformer/ Reactor to be installed in future. However, for the purpose of design it shall be assumed that only one Transformer/ Reactor will be on fire. **The main header pipe size in the yard shall be 250mmNB (for 400kV and above level substations) and 200mmNB(for 220kV & 132kV substations). Branch to the equipment (shall not be more than 20metres length) shall be of the same size as of deluge valve.**

2.02.01 The Electrical clearance between the Emulsifier system pipe work and live parts of the protected equipment shall not be less than the values given below :

1.	765 kV bushing	4900 mm
2.	420 kV bushing	3500 mm
3.	245 kV bushing	2150 mm
4.	145 kV bushing	1300 mm
5.	52 kV bushing	630 mm
6.	36 kV bushing	320 mm

2.02.02 System shall be designed in such a way that the Water pressure available at any spray nozzle shall be between 3.5bar and 5.0bar and shall be demonstrated through hydraulic calculations. Water shall be applied at a minimum rate of 10.2 LPM/M<sup>2</sup> of the surface area of the transformer / Reactor including radiator, conservator, oil pipes, bushing turrets, etc. (including bottom surface for transformer). The nozzle arrangement shall ensure direct impingement of water on all exterior surfaces of transformer tank, bushing turrets, conservator and oil pipes, except underneath the transformer, where horizontal spray may be provided. Typical drawings of HVW spray system of a transformer and a reactor is enclosed at Annexure-III for reference.

### 2.02.03 **Deluge Valve**

Deluge Valve shall be water pressure operated manual reset type. The Deluge valve shall be closed water tight when water pressure in the heat detector pipe work is healthy and the entire pipe work shall be charged with water under pressure upto the inlet of the Deluge valve. On fall of water pressure due to opening of one or more heat detectors, the valve shall open and water shall rush to the spray water network through the open Deluge valve. The valves shall be manually reset to initial position after completion of operation. Each Deluge Valve shall be provided with a water motor gong which shall sound an alarm when water after passing through the Deluge valve, is tapped through the water motor.

Each Deluge valve shall be provided with a local panel with provision of opening of Deluge valve from local and remote from control room/ remote centre. In addition to this, each valve shall be provided with local operation latch.

Deluge valves of 100mmNB size shall be used if the flow requirement is  $\leq 200\text{m}^3/\text{hr}$  and 150mmNB size shall be used for flow requirement  $>200\text{m}^3/\text{hr}$ .

Test valves shall simulate the operation of Deluge valves and shall be of quick opening type. The general construction shall conform to requirements under clause no.7.00.00 for piping, valves and specialities.

### 2.02.04 **High Velocity Spray Nozzles (Projectors)**

High velocity spray system shall be designed and installed to discharge water in the form of a conical spray consisting of droplets of water travelling at high velocity, which shall strike the burning surface with sufficient impact to ensure the formation of an emulsion. At the same time the spray shall efficiently cut off oxygen supply and provide sufficient cooling.

2.02.05 Minimum set point of the heat detectors used in the HVW spray system shall be 79°C. The optimum rating shall, however, be selected by the Bidder, keeping in mind the maximum and minimum temperature attained at site.

2.03.00 **Fire Detection and alarm System**

This system shall be provided for control room building and Switchyard panel rooms of substations.

2.03.01 Suitable fire detection system using smoke detectors and/or heat detectors shall be provided for the entire building, including corridor and toilets. Fire detectors shall be located at strategic locations in various rooms of the building. Each Switchyard panel room shall be considered a separate zone. Adequate number of extra zones shall be provided for Switchyard panel rooms for future bays identified in Single line diagram of the substation. The operation of any of the fire detectors/ manual call point should result in the following;

1. A visual signal exhibited in the annunciation panels indicating the area where the fire is detected.
2. An audible alarm sounded in the panel, and
3. An external audible alarm sounded in the building, location of which shall be decided during detailed engineering.
4. If the zone comprises of more than one room, a visual signal shall be exhibited on the outer wall of each room.

2.03.02 Each zone shall be provided with two zone cards in the panel so that system will remain healthy even if one of the cards becomes defective.

2.03.03 Coverage area of each smoke detector shall not be more than 80 m<sup>2</sup> and that of heat detectors shall not be more than 40 m<sup>2</sup>. Ionisation type smoke detectors shall be provided in all areas except pantry room where heat detectors shall be provided. If a detector is concealed, a remote visual indication of its operation shall be provided. Manual call points (Break glass Alarm Stations) shall be provided at strategic locations in the control room building. All cabling shall be done through concealed conduits.

2.03.04 Cables used should be exclusively for fire detection and alarm system and shall be 2Cx1.5sq.mm Cu. cables. Un-armoured PVC insulated FR cables conforming to IS 1554 (Part 1) shall be used.

2.04.00 Portable and Wheel/ Trolley mounted Fire Extinguishers

#### 2.04.01 Portable Fire Extinguishers

Adequate number of portable fire extinguishers of pressurised water, dry chemical powder, and Carbon dioxide type shall be provided in suitable locations in control room building and FFPH building as indicated in the drawing. In addition to this one (1) CO2 type fire extinguisher of 4.5kg capacity shall be provided for each Switchyard panel room. These extinguishers will be used during the early phases of fire to prevent its spread and costly damage.

The design, construction & testing of portable fire extinguishers shall meet the requirements as per clause 10.00.00.

#### 2.04.02 Wheel/ Trolley mounted Fire Extinguishers

Wheel/Trolley mounted Mechanical foam type fire extinguishers of 50litre capacity, conforming to IS:13386, shall be provided for the protection of the following:

1. Transformers and reactors in 220kV and 132 kV substations **where Hydrant/HVWS system is not available.** Two (2) nos. for each 220kV or 132kV transformer and reactor.
2. LT transformers in all substations. One (1) no. for each **LT** transformer.

The design, construction & testing of Mechanical foam type 50 litre capacity shall meet the requirements of relevant IS Codes and clause 10.00.00 of this specification.

#### 2.05.00 Water Supply System

For 400kV and above level substations water for hydrant & HVW system shall be supplied by one electrical motor driven pump of rated capacity 410m<sup>3</sup>/hr. at 70MWC head **& for 220kV and 132kV substations water for hydrant & HVWS system shall be supplied by one electrical motor driven pump of rated capacity 273m<sup>3</sup>/hr. at 70MWC head,** with another pump of same capacity , driven by diesel engine, shall be used as standby. Water storage tank with two compartments of adequate capacity shall be provided. Pumps shall work under positive suction head. Annunciations of the hydrant & HVW spray systems shall be provided in fire water pump house and repeated in control room. **Provision for sending data to remote control centre shall also be available.**

The outdoor piping for the system in general shall be laid above ground on concrete pedestals with proper supporting arrangement. However, at

road/rail crossings, in front/access of buildings, places where movement of cranes/vehicles is expected and at any other place where above ground piping is not advisable, the pipes shall be laid underground. Such locations shall be finalised during detailed engineering.

The whole system will be kept pressurised by providing combination of air vessel and jockey pump of 10.8M<sup>3</sup>/hr. capacity at 80MWC. The capacity of air vessel shall not be less than 3m<sup>3</sup>. Minor leakage will be met by Jockey pump. One additional jockey pump shall be provided as standby. All pumps shall be of horizontal centrifugal type. Pumps and air vessel with all auxiliary equipment will be located in firewater pump house. A pressure relief valve of suitable rating shall be provided in water header to release excess pressure due to atmospheric temperature variations.

Operation of all the pumps shall be automatic and pumps shall be brought into operation at preset pressure. Fire pumps shall only be stopped manually. Manual start/stop provision shall be provided in local control panel.

- 2.05.01 The general design of the fire fighting pump sets shall meet the requirements under clauses no.5.00.00 for Horizontal centrifugal pumps, no.6.00.00 for Diesel engines and no.12.00.00 for Electrical motors.
- 2.05.02 Each pump shall be provided with a nameplate indicating suction lift/delivery head, capacity and number of revolutions per minute.
- 2.05.03 Design, construction, erection, testing and trial operation of piping, valves, strainers, hydrant valves, hoses, nozzles, branch pipes, hose boxes, expansion joints etc. shall conform to the requirements of clause no. 7.00.00.

#### 2.06.00 **Instrumentation and Control System**

- 2.06.01 All instruments like pressure indicators, differential pressure indicators, pressure switches, level indicators, level switches, temperature indicators, alarms and all other instruments and panels as indicated in the specification and drawings and those needed for safe and efficient operation of the whole system shall be furnished according to the requirements of clause 11.00.00. Pump running/ fails to start signal shall be taken from the pressure switch immediately after the discharge of the pump.

#### 2.06.02 **Control Panel**

Power feeder for motors will be from switchgear board located in control

building but control supply for all local control panels, annunciation panels, battery charger units, space heaters etc. shall be fed from the AC and DC distribution boards located in pump house. These AC & DC distribution boards will be fed from the switchgears and DCDBs located in control building.

a) Panel for motor driven fire water pump

The panel shall be provided with the following:

- |    |  |       |
|----|--|-------|
| 1. | TPN switch   | 1 No. |
| 2. | <b>Auto/manual selection facility</b>              |       |
| 3. | <b>Start/Stop facility</b><br>with indication lamp | 1 Set |
| 4. | DOL starter with<br>thermal O/L relay              | 1 Set |
| 5. | Indicating lamp showing<br>power ON                | 1 Set |
| 6. | Indication lamp with drive<br>ON/OF                | 1 Set |
| 7. | Indication lamp showing<br>Motor Trip              | 1 No. |

**Additional provisions shall be made for controlling the following from the remote control centre:**

**1. Auto/manual selection facility**

**2. Start/Stop facility**

Main power cable from breaker feeder of main switchboard shall be terminated in this panel and another cable shall emanate from this panel which shall be terminated at motor terminals.

b) Panel for Two nos. Jockey Pump 1No.

The panel shall be provided with the following :

- |    |                                   |                     |
|----|-----------------------------------|---------------------|
| 1. | Fuse-switch unit for Jockey pumps | 1 Set for each pump |
|----|-----------------------------------|---------------------|

- |    |  |                     |
|----|--|---------------------|
| 2. | <b>Auto/manual selection facility for each pump</b>  |                     |
| 3. | Selector switch for selecting either jockey pump   | 1 No.               |
| 4. | D.O.L. starter with overload relay self-resetting type, for all the drives.                                | 1 No. each          |
| 5. | Start/stop push button for Jockey Pump with indication lamp with pad-locking arrangements in stop position | 1 Set for each pump |
| 6. | Indication lamp for trip indication  | 1 No. each for pump |

**Additional provisions shall be made for controlling the following from the remote control centre:**

**1. Auto/manual selection facility for each pump.**

- |    |   |       |
|----|---|-------|
| c) | Panel for 2 Nos. battery charger & Diesel Engine driven fire water pump | 1 No. |
|----|---|-------|

The panel shall be provided with the following :

- |    |   |            |
|----|---|------------|
| 1. | <b>Auto/Manual selection facility</b> for Diesel Engine driven pump | 1 No.      |
| 2. | <b>Start/Stop facility</b> with indication lamp                     | 1 Set      |
| 3. | Indicating lamp showing drive ON/OFF                                | 1 Set      |
| 4. | D.C. Voltmeter/Ammeter in the battery charger circuit               | 1 No. each |
| 5. | Battery charger will be as per specification described              | 1 Set      |
| 6. | Selector switch for selecting                                       | 1 No.      |

either of battery chargers for the battery sets.

- |    |   |       |
|----|---|-------|
| 7. | Selector switch for selecting either set of batteries for Diesel engine starting. | 1No.  |
| 8. | Selector switch for boost charging/Trickle charging of battery set.               | 1 Set |

**Additional provisions shall be made for controlling the following from the remote control centre:**

**1. Manual Start/Stop of Diesel Engine**

- d) Individual local control panel is to be considered for each transformer/ Reactor deluge system wherever these equipment are envisaged. This panel shall contain push buttons with indicating lamps for spray ON/OFF operation in the valve operation circuit. Push buttons shall be concealed behind glass covers, which shall be broken to operate the buttons. Provision shall be made in the panel for the field signal for the annunciations such as spray ON and fire in the Transformer/Reactor. A signal for spray ON shall also be provided in the control room fire alarm panel for employer's event logger. Remote operation facility to open the Deluge valve from control room/ remote centre shall also be provided.

**2.06.03 Annunciation Panels**

**a) Location: Fire Water Pump House**

- i) Indicating lamps showing power supply "ON".
- ii) Annunciation windows complete with buttons. Details are as follows:

Sl.No.	Description	Number
1.	Electric motor driven fire water pump running	1
2.	Electric motor driven fire water pump fails to start	1
3.	Diesel engine driven fire water pump running.	1
4.	Diesel engine driven water pump fails	1

	to start	
5.	Jockey pump-1 running	1
6.	Jockey pump-1 fails to start	1
7.	Jockey pump-2 running	1
8.	Jockey pump-2 fails to start	1
9.	Fire in Transformer/ Reactor	1 for each equipment
10.	Deluge system operating for Transformer/Reactor	1 for each equipment
11.	Header pressure low	1
12.	Fire in smoke detection system zone (Common Fire Signal)	1
13.	Water storage tank water level low	2
14.	High speed diesel tank level low	1
15.	Spare	10

-----

b) **Location: Substation Control Room**

- i) Indication lamp showing power supply 'ON'
- ii) Provision shall be made in the panel for a signal for spray ON for each Transformer/Reactor for owner's use for event logger.
- iii) Each Switchyard panel room shall be considered as separate zone for fire detection and alarm system.
- iv) Following annunciations shall be provided.

-----

Sl.No.	Description	Number
--------	-------------	--------

-----

1.	Fire in Transformer/ Reactor	1 for each equipment
2.	Diesel engine driven fire water pump in operation	1
3.	Motor driven fire water pump in operation	1
4.	Jockey pump in operation	1
5.	Fire fighting Water storage tank level Low	2
6.	Fire/Fault (zone alarm module)	1+1(duplicate) For each zone as applicable
7.	Spare windows complete in all respect, with relays	10
8.	Spare zone alarm modules	Number of future A/c Kiosks required for the bays identified as per SLD

-----

c) Each annunciation panel shall be provided with a hooter. **A hooter in parallel to the hooter in fire panel shall be provided in the security room of substation for alert in case of fire.**

d) Indication for fault in respective areas shall also be provided. Each zone alarm module shall exhibit 'FIRE' and 'FAULT' conditions separately.

**e) Provision for sending data to Remote Control Unit for the following**

**(i) Fire in Switchyard Panel Room (Switchyard Panel room shall be considered as separate zone for fire detection and alarm system).**

**(ii) Fire in Transformer/Reactor (1 for each equipment)**

**(iii) Diesel engine driven fire water pump in operation.**

**(iv) Motor driven fire water pump in operation**

**(v) Fire/Fault in Control Room.**

**(vi) Water Storage tank level (low and very low for each storage tank).**

**(vii) High Speed Diesel tank level (low & very low)**

**(viii) AC Mains Supply Healthy/Fail for Main Pump & Jockey Pump**

**(ix) DC Control Supply Healthy/Fail for Main Pump & Jockey Pump**

**(x) DC Control Supply Healthy/Fail for Diesel Engine driven pump.**

2.06.04 The control and interlock system for the fire protection system shall meet the following requirements:

**1. Electric Motor Driven Fire water Pump**

Pump should start automatically when the System header pressure is low.

Pump should be stopped manually only. Pump should also be started manually if required from local control panel.

**2. Diesel Engine Driven Standby Pump**

The pump should automatically start under any of the following conditions:

- a) System Header pressure low.
- b) Electric motor operated fire water pump fails to start.

Pump should be stopped manually only. Pump should also be started manually if required from the local control panel. The battery set which is connected for starting of Diesel engine shall not be subjected to boost charge.

**3. Jockey Pump**

It shall be possible to select any one of the Jockey pumps as main and the other as standby. Main Jockey pump shall start automatically when water pressure in header falls below the set value. If the main jockey pump fails to start then the standby should start. Jockey pump shall stop automatically when the pressure is restored to its normal value.

Manual starting/stopping shall be possible from the local control

panel.

**3.00.00 TESTS**

**3.01.00 Shop Tests**

3.01.01 Shop tests of all major equipment centrifugal pumps, diesel engines, electrical drive motors, piping, valves and specialties, pressure and storage vessels, MCC, electrical panels, controls, instrumentation etc. shall be conducted as specified in various clauses and as per applicable standards/codes.

3.01.02 Shop tests shall include all tests to be carried out at Contractor's works, works of his sub-contractor and at works where raw materials supplied for manufacture of equipment are fabricated. The tests to be carried out shall include but not be limited to the tests described as follows :

- a) Materials analysis and testing.
- b) Hydrostatic pressure test of all pressure parts, piping, etc.
- c) Dimensional and visual check.
- d) Balancing test of rotating components.
- e) Response of heat/smoke detectors.
- f) Performance characteristics of HVW spray nozzles (projectors).
- g) Flow rate and operational test on Flow control valves.
- h) Operational test of alarm valve (water-motor gang).
- i) Calibration tests on instruments and tests on control panel.
- j) Destruction/burst tests on 2% or minimum one (1) no. of hoses and portable type fire extinguishers for each type as applicable. Any fraction number shall be counted as next higher integer.
- k) Performance test on fire extinguishers as required in the code.

3.01.03 In the absence of any Code/Standard, equipment shall be tested as per mutually agreed procedure between the supplier and the Employer.

3.01.04 A comprehensive visual and functional check for panels would be conducted and will include a thorough check up of panel dimensions,

material of construction, panel finish, compliance with tubing and wiring specifications, quality of workmanship, proper tagging & locations of instruments/accessories. The wiring check shall be complete point to point ring out and check for agreement with installation drawings and equipment vendor prints of the complete system and an inspection of all field connection terminals and levelling.

3.01.05 All test certificates and reports shall be submitted to the Employer for approval.

3.01.06 The Employer's representative shall be given full access to all tests. The manufacturer shall inform the Employer allowing adequate time so that, if the Employer so desires, his representatives can witness the test.

### 3.02.00 **Pre-commissioning Tests**

#### 3.02.01 **General**

- a) All piping and valves, after installation will be tested hydraulically at a pressure of  $16\text{kg/cm}^2$  for a period of 30 minutes to check against leak tightness.
- b) All manually operated valves/gates shall be operated throughout 100% of the travel and these should function without any trouble whatsoever, to the satisfaction of the Employer.
- c) All pumps shall be run with the specified fluid from shut off condition to valve wide open condition. Head developed will be checked from the discharge pressure gauge reading. During the test, the pumps and drives shall run smoothly without any undue vibration, leakage through gland, temperature rise in the bearing parts, noise, flow pulsation etc.
- d) All pressure vessels should be tested hydraulically at the specified test pressure, singly or in the system.
- e) Painting shall be checked by dry type thickness gauges.
- f) Visual check on all structural components, welding, painting etc. and if doubt arises, these will be tested again.
- g) All test instruments and equipment shall be furnished by the Contractor to the satisfaction of the Employer.
- h) Automatic starting of all the fire pumps by operating the test valves.

- i) Automatic operation of the Jockey pump
- j) Operation of the Deluge valve by breaking a detector as well as manual and remote operation of the deluge valve.
- k) Operation of entire annunciation system.

Replacement of fused/damaged quartzoid bulb detectors during the test shall be responsibility of contractor.

- 3.02.02 After erection at site, the complete HVW spray protection and hydrant system shall be subject to tests to show satisfactory performance for which detailed procedure shall be submitted for Employer's approval.

Full flow tests with water shall be done for the system piping as a means of checking the nozzle layout, discharge pattern and coverage, any obstructions and determination of relation between design criteria and actual performance, also to ensure against clogging of the smaller piping and the discharge devices by foreign matter carried by the water.

Rigidity of pipe supports shall also be checked during the water flow.

- 3.02.03 All the detectors installed shall be tested for actuation by bringing a suitable source of heat/smoke near the detector and creating a stream of hot air/ smoke over the detector. The exact procedure of this test shall be detailed out by the Employer to the successful Bidder.

#### 4.00.00 **SPARE PARTS**

The Contractor shall indicate in his scope of supply all the mandatory spares in the relevant schedules. The list of mandatory spares is indicated in 'Section - Projects'.

#### 5.00.00 **HORIZONTAL CENTRIFUGAL PUMPS**

This clause covers the design, performance, manufacturing, construction features and testing of horizontal centrifugal pumps used for the purpose of fire fighting.

- 5.01.00 The materials of the various components shall conform to the applicable IS/BS/ASTM/DIN Standards.

- 5.01.01 In case of any contradiction with the aforesaid standards and the stipulations as per the technical specification as specified hereinafter, the stipulations of the technical specification shall prevail.

#### 5.02.00 **General Performance Requirements**

- 5.02.01 The pump set shall be suitable for continuous operation at any point within the "Range of operation".
- 5.02.02 Pumps shall have a continuously rising head capacity characteristics from the specified duty point towards shut off point, the maximum being at shut off.
- 5.02.03 Pumps shall be capable of furnishing not less than 150% of rated capacity at a head of not less than 65% of the rated head. The shut off head shall not exceed 120% of rated head. Range of operation shall be 20% of rated flow to 150% of rated flow.
- 5.02.04 The pump-motor set shall be designed in such a way that there is no damage due to the reverse flow through the pump which may occur due to any mal-operation of the system.
- 5.02.05 **Drive Rating**
- The drive rating shall not be less than the maximum power requirement at any point within the "Range of Operation" specified.
- During starting under reverse flow condition, the motor shall be capable of bringing the pump to rated speed at normal direction with 90% rated voltage at motor terminals.
- 5.02.06 Pump set along with its drive shall run smooth without undue noise and vibration. Acceptable peak to peak vibration limits shall generally be guided by Hydraulic Institute Standards.
- 5.02.07 The Contractor under this specification shall assume full responsibility in the operation of the pump and drive as one unit.
- 5.03.00 **Design & Construction**
- 5.03.01 Pump casing may be axially or radially split. The casing shall be designed to withstand the maximum pressure developed by the pump at the pumping temperature.
- 5.03.02 Pump casing shall be provided with adequate number of vent and priming connections with valves, unless the pump is made self-venting & priming. Casing drain, as required, shall be provided complete with drain valves.
- 5.03.03 Under certain conditions, the pump casing nozzles will be subjected to reactions from external piping. Pump design must ensure that the nozzles are capable of withstanding external reactions not less than those specified in API-610.
- 5.03.04 Pump shall preferably be of such construction that it is possible to

service the internals of the pump without disturbing suction and discharge piping connections.

**5.03.05 Impeller**

The impeller shall be secured to the shaft and shall be retained against circumferential movement by keying, pinning or lock rings. On pumps with overhung shaft impellers shall be secured to the shaft by an additional locknut or cap screw. All screwed fasteners shall tighten in the direction of normal rotation.

**5.03.06 Wearing Rings**

Replaceable type wearing rings shall be furnished to prevent damage to impeller and casing. Suitable method of locking the wearing ring shall be used.

**5.03.07 Shaft**

Shaft size selected shall take into consideration the critical speed, which shall be at least 20% away from the operating speed. The critical speed shall also be atleast 10% away from runaway speed.

**5.03.08 Shaft Sleeves**

Renewable type fine finished shaft sleeves shall be provided at the stuffing boxes/mechanical seals. Length of the shaft sleeves must extend beyond the outer faces of gland packing or seal and plate so as to distinguish between the leakage between shaft & shaft sleeve and that past the seals/gland.

5.03.09 Shaft sleeves shall be securely fastened to the shaft to prevent any leakage or loosening. Shaft and shaft sleeve assembly should ensure concentric rotation.

**5.03.10 Bearings**

Bearings of adequate design shall be furnished for taking the entire pump load arising from all probable conditions of continuous operation throughout its "Range of Operation" and also at the shut-off condition. The bearing shall be designed on the basis of 20,000 working hours minimum for the load corresponding to the duty point.

Bearings shall be easily accessible without disturbing the pump assembly. A drain plug shall be provided at the bottom of each bearing housing.

**5.03.11 Stuffing Boxes**

Stuffing box design shall permit replacement of packing without

removing any part other than the gland. Stuffing boxes shall be sealed/cooled by the fluid being pumped and necessary piping, fittings, valves, instruments, etc. shall form an integral part of the pump assembly.

#### 5.03.12 **Shaft Couplings**

All shafts shall be connected with adequately sized flexible couplings of suitable design. Necessary guards shall be provided for the couplings.

#### 5.03.13 **Base Plates & Sole Plate**

A common base plate mounting both for the pump and drive shall be furnished.

The base plate shall be of rigid construction, suitably ribbed and reinforced. Base plate and pump supports shall be so constructed and the pumping unit so mounted as to minimise misalignment caused by mechanical forces such as normal piping strain, hydraulic piping thrust etc. Suitable drain taps and drip lip shall be provided.

#### 5.03.14 **Material of Construction**

All materials used for pump construction shall be of tested quality. Material of construction of the major parts of the pumps shall be as given below :

a) Casing	Casting Grade FG: 260 of IS 210
b) Impeller	Bronze Grade LTB 2 of IS:318
c) Wearing ring	Bronze Grade LTB 2 of IS:318
d) Shaft	Grade 40C8 of IS 1570 (Part 2, section 1.): 1979.
e) Shaft sleeve	Bronze Grade LTB 2 of IS:318 or Chrome steel 07Cr13 of IS 1570 (part 5) :1985.
f) Stuffing box	2.5% Nickel CI Grade FG 260 of IS:210
g) Gland	--- do ---

#### 5.03.15 **Balancing**

All rotating components shall be statically and dynamically balanced at

shop.

5.03.16 All the components of pumps of identical parameters supplied under this specification shall be interchangeable.

5.04.00 **Tests and Inspection**

5.04.01 The manufacturer shall conduct all routine tests required to ensure that the equipment furnished conform to the requirements of this specification and are in compliance with the requirements of applicable Codes and Standards. The particulars of the proposed tests and the procedures for the tests shall be submitted to the Employer/Engineer for approval before conducting the tests.

5.04.02 Where stage inspection is to be witnessed by Employer, in addition to above, the Bidder shall submit to the Employer/Engineer at the beginning of the contract, the detailed PERT-Chart showing the manufacturing programme and indicating the period where Employer or his authorised inspecting agency are required at the shop.

5.04.03 **Material of Construction**

All materials used for pump construction shall be of tested quality. Materials shall be tested as per the relevant standards and test certificates shall be made available to the Employer/Engineer.

5.04.04 Where stage inspection is to be witnessed by Employer, all material test certificates shall be correlated and verified with the actual material used for construction before starting fabrication, by Employer's Inspector who shall stamp the material. In case mill test certificates for the material are not available, the Contractor shall carry out physical and chemical tests at his own cost from a testing agency approved by the Employer, as per the requirements of specified material standard. The samples for physical and chemical tests shall be drawn up in presence of Employer's inspector who shall also witness the tests.

5.04.05 Shaft shall be subjected to 100% ultrasonic test and machined portion of the impeller shall be subject to 100% DP test. On finished shaft DP test will also be carried out.

5.04.06 **Hydraulic test at shop**

All pressure parts shall be subjected to hydraulic testing at a pressure of 150% of maximum pressure generated by the pump at rated speed or 200% of total dynamic head whichever is higher, for a period not less than one (1) hour.

5.04.07 **Performance test at shop**

Pumps shall be subjected to routine tests to determine the performance of the pumps. These tests shall be conducted in presence of

Employer/Engineer's representative as per the requirements of the Hydraulic Institute Standards/ASME Power Test Code PTC 8.2/BS-599/I.S.S., latest edition. Routine tests shall be done on all the pumps.

- 5.04.08 Performance tests shall be conducted to cover the entire range of operation of the pumps. These shall be carried out to span 150% of rated capacity upto pump shut-off condition. A minimum of five combinations of head and capacity are to be achieved during testing to establish the performance curves, including the design capacity point and the two extremities of the Range of operation specified.
- 5.04.09 Tests shall preferably be conducted alongwith the actual drives being supplied.
- 5.04.10 The Bidders shall submit in his proposal the facilities available at his works to conduct performance testing. If because of limitations of available facilities, a reduced speed test or model test has to be resorted to establish pump performance, the same has to be highlighted in the offer.
- 5.04.11 In case of model testing, the stipulations of latest edition of Hydraulic Institute Standards shall be binding. Prototype or model tests, however, shall be conducted with the suction condition identical to the field conditions i.e. sigma values of prototype and model is to be kept same.
- 5.04.12 Prior to conducting model testing, calculations establishing model parameters, sizes and test procedure will be submitted to Employer/Engineer for approval.
- 5.04.13 All rotating components of the pumps shall be subjected to static and dynamic balancing tests.
- 5.04.14 The Employer or his authorised representative shall have full access to all tests. Prior to performance tests, the Contractor shall intimate the Employer allowing adequate time so that if the Employer so desires, his representative can witness the test.
- 5.04.15 Report and test certificates of the above tests shall be submitted to the Employer/Engineer for approval.
- 5.04.16 **Pre commissioning tests.**

After installation, pumps offered may be subjected to testing at field also by Employer. If the performances at field are not found to meet the requirement, then the equipment shall be rectified by the Contractor without any extra cost. Prior to performance testing, the procedure for such tests will be mutually agreed between Employer and Contractor. The Contractor shall furnish all necessary instruments, accessories and personnel for testing. Prior to testing, the calibration curves of all instruments and permissible tolerance limit of instruments shall be mutually agreed upon.

## 6.00.00 **DIESEL ENGINES**

This Clause covers the design, performance, manufacturing construction features and testing of compression ignition diesel engines, used primarily for driving centrifugal pumps, used for the purpose of fire fighting.

### 6.01.00 **Design and Construction**

#### **General**

6.01.01 The diesel engine shall be of multicylinder type four-stroke cycle with mechanical (airless) injection, cold starting type.

6.01.02 The continuous engine brake horse power rating (after accounting for all auxiliary power consumption) at the site conditions shall be atleast 20% greater than the requirement at the duty point of pump at rated RPM and in no case, less than the maximum power requirement at any condition of operation of pump.

6.01.03 Reference conditions for rated output of engine shall be as per IS:10000, part II or ISO:3046, part I.

6.01.04 The engine shall be designed with regard to ease of maintenance, repair, cleaning and inspection.

6.01.05 All parts subjected to substantial temperature changes shall be designed and supported to permit free expansion and contraction without resulting in leakage, harmful distortion or misalignment.

#### 6.01.06 **Starting**

The engine shall be capable of both automatic and manual start. The normal mode of starting is automatic but in the event of failure of automatic start or at the discretion of the operator, the engine can be started manually from the LCP.

Since the fire pumping unit driven by the diesel engine is not required to run continuously for long periods and the operation will not be frequent, special features shall be built into the engine to allow it to start within a very short period against full load even if it has remained idle for a considerable period.

6.01.07 If provision for manual start (cranking) is provided, all controls/mechanisms, which have to be operated during the starting process, shall be within easy reach of the operator.

6.01.08 Automatic cranking shall be effected by a D.C. motor having high starting torque to overcome full engine compression. Starting power will

be supplied from either of the two (2) sets of storage batteries. The automatic starting arrangement shall include a 'Repeat Start' feature for 3 attempts. The battery capacity shall be adequate for 3 (three) consecutive starts without recharging with a cold engine under full compression.

- 6.01.09 The batteries shall be used exclusively for starting the diesel engine and be kept fully charged all the time in position. Arrangement for both trickle and booster charge shall be provided.

Diesel engine shall be provided with two (2) battery charger units of air-cooled design. The charger unit shall be capable of charging one (1) set of battery at a time. Provision shall, however, be made so that any one of the charger units can be utilised for charging either of the two (2) batteries.

- 6.01.10 For detail design of battery and battery charger, sub-section Electrical may be referred to.

6.01.11 **Governing System:**

The engine shall be fitted with a speed control device, which will control the speed under all conditions of load.

- 6.01.12 The governor shall offer following features:

a) Engine should be provided with an adjustable governor capable of regulating engine speed within 5% of its rated speed under any condition of load between shut-off and maximum load conditions of the pumps. The governor shall be set to maintain rated pump speed at maximum pump load.

b) Engine shall be provided with an over speed shut-down device. It shall be arranged to shut-down the engine at a speed approximately 20% above rated engine speed and for manual reset, such that the automatic engine controller will continue to show an over speed signal until the device is manually reset to normal operating position (Vol.II, NFPA, 1978).

- 6.01.13 The governor shall be suitable for operation without external power supply.

6.01.14 **Fuel System**

The diesel engine will run on High Speed Diesel.

- 6.01.15 The engine shall be provided with fuel oil tank of 250 litres capacity. The fuel oil tank shall preferably be mounted near the engine. No fuel oil tank will be provided by the Employer.

- 6.01.16 The fuel oil tank shall be of welded steel constructed to relevant standards for mild steel drums. The outlet of the tank shall be above the inlet of fuel injection pump of the diesel engine to ensure adequate pressure at suction of injection pump.
- 6.01.17 The fuel oil tank shall be designed in such a way that the sludge and sediment settles down to the tank bottom and is not carried to the injection pump. A small sump shall be provided and fitted with drain plug to take out sludge/sediment and to drain oil. Adequate hand holes (greater than 80 mm size) shall be provided to facilitate maintenance.
- 6.01.18 Pipeline carrying fuel oil shall be gradually sloped from the tank to the injection pump. Any valve in the fuel feed pipe between the fuel tank and the engine shall be placed adjacent to the tank and it shall be locked in the open position. A filter shall be incorporated in this pipeline, in addition to other filters in the fuel oil system. Pipe joints shall not be soldered and plastic tubing shall not be used. Reinforced flexible pipes may also be used.
- 6.01.19 The complete fuel oil system shall be designed to avoid any air pocket in any part of the pipe work, fuel pump, sprayers/injectors, filter system etc. No air relief cock is permitted. However, where air relief is essential, plugs may be used.
- 6.01.20 A manual fuel pump shall be provided for priming and releasing of air from the fuel pipelines.

6.01.21 **Lubricating Oil System**

Automatic pressure lubrication shall be provided by a pump driven by the crank shaft, taking suction from a sump and delivering pressurised oil through cooler and fine mesh filters to a main supply header fitted in the bed plate casing. High pressure oil shall be supplied to the main and big end bearings, cam-shaft bearings, cam-shaft chain and gear drives, governor, auxiliary drive gears etc. Valve gear shall be lubricated at reduced pressure through a reducing valve and the cams by an oil bath.

6.01.22 **Cooling Water System**

Direct cooling or heat exchanger type cooling system shall be employed for the diesel engine. Water shall be tapped from the fire pump discharge. This water shall be led through duplex strainer, pressure breakdown orifice and then after passing through the engine, the water at the outlet shall be taken directly to the sump through an elevated funnel.

6.02.00 **Testing & Inspection**

- 6.02.01 The manufacturer shall conduct all tests required, to ensure that the equipment furnished conforms to the requirement of this sub-section

and in compliance with requirements of applicable codes. The particulars of the proposed tests and the procedure for the tests shall be submitted to the Employer for approval before conducting the tests.

- 6.02.02 At manufacturer's works, tests shall be carried out during and after completion of manufacture of different component/parts and the assembly as applicable. Following tests shall be conducted.
- 6.02.03 Material analysis and testing.
- 6.02.04 Hydrostatic pressure testing of all pressure parts.
- 6.02.05 Static and dynamic balance tests of rotating parts at applicable over-speed and determination of vibration level.
- 6.02.06 MPI/DPT on machined parts of piston and cylinder.
- 6.02.07 Ultrasonic testing of crankshaft and connecting rod after heat treatment.
- 6.02.08 Dimensional check of close tolerance components like piston, cylinder bore etc.
- 6.02.09 Calibration tests of all fuel pumps, injectors, standard orifices, nozzles, instruments etc.
- 6.02.10 Over speed test of the assembly at 120% of rated speed.
- 6.02.11 Power run test.
- 6.02.12 Performance test of the diesel engine to determine its torque, power and specific fuel consumption as function of shaft speed. Performance test of the engine shall be carried for 12 hours out of which 1 hour at full load and one hour at 110% overload.
- 6.02.13 Measurement of vibration & noise.

(i) Measurement of vibration

The vibration shall be measured during full load test as well as during the overload test and limit shall be 100 microns.

(ii) Measurement of noise level

The equivalent 'A' weighted sound level measured at a distance of 1.5 M above floor level in elevation and 1.0 M horizontally from the base of the equipment, expressed in dB to a reference of 0.0002 microbar shall not exceed 93 dBA.

Above tests for vibration shall be repeated at site as pre-commissioning

tests.

6.02.14 Adjustment of speed governor as per BS:5514.

6.02.15 Diesel engine shall be subjected to routine tests as per IS:10000/BS:5514.

#### 7.00.00 **PIPING, VALVES AND SPECIALITIES**

This clause covers the design, manufacture, shop testing, erection, testing and commissioning of piping, valves and specialities.

##### 7.02.00 **Scope**

The piping system which shall include but not be limited to the following:

7.02.01 Plain run of piping, bends, elbows, tees, branches, laterals, crosses, reducing unions, couplings, caps, expansion joints, flanges, blank flanges, thrust blocks, anchors, hangers, supports, saddles, shoes, vibration dampeners, sampling connections, hume pipes etc.

7.02.02 Gaskets, ring joints, backing rings, jointing material etc. as required. Also all welding electrodes and welding consumables including special ones, if any.

7.02.03 Instrument tapping connections, stubs etc.

7.02.04 Gate and globe valves to start/stop and regulate flow and swing check valves for one directional flow.

7.02.05 Basket strainers and Y-type strainers

7.02.06 Bolts, nuts, fasteners as required for interconnecting piping, valves and fittings as well as for terminal points. For pipe connections into Owner's R.C.C. works, Bidder will furnish all inserts.

7.02.07 Painting, anti-corrosive coatings etc. of pipes and equipment.

Adequate number of air release valves shall be provided at the highest points in the piping system to vent any trapped air in the system.

##### 7.03.00 **Design**

7.03.01 Material of construction of various pipes shall be as follows :

###### (a) **Buried Pipes**

Mild steel black pipes as per IS:1239, Part-I medium grade (for pipes of sizes 150 NB and below) or IS:3589, Fe 410 grade (for pipes of sizes 200 NB and above) suitably lagged on the outside to

prevent soil corrosion, as specified elsewhere.

(b) **Overground Pipes normally full of water**

Mild steel black pipes as per IS:1239, Part-I medium grade (for pipes for sizes 150 NB and below) or IS:3589, Fe 410 grade (for pipes of sizes 200 NB and above).

(c) Overground pipes normally empty, but periodic charge of water and for detector line for HVW System.

Mild steel galvanised pipes as per IS:1239, Part-I medium grade (for pipes of sizes 150 NB and below) or IS:3589, Fe 410 grade (for pipes of sizes 200 NB and above).

- 7.03.02 All fittings to be used in connection with steel pipe lines upto a size of 80 mm shall be as per IS:1239. Part-II Mild steel tubulars and other wrought steel pipe fittings, Heavy grade. Fittings with sizes above 80 mm upto 150 mm shall be fabricated from IS:1239 Heavy grade pipes or steel plates having thickness not less than those of IS:1239 Part-I Heavy grade pipes. Fittings with sizes above 150 mm shall be fabricated from IS:3589 Class-2 pipes. All fitting used in GI piping shall be threaded type. Welding shall not be permitted on GI piping.
- 7.03.03 Pipe sizes shall not be less than the sizes indicated in the attached drawings.
- 7.03.04 For steel pipeline, welded construction should be adopted unless specified otherwise.
- 7.03.06 All piping system shall be capable of withstanding the maximum pressure arising from any condition of operation and testing including water hammer effects.
- 7.03.09 Gate/sluice valve shall be used for isolation of flow in pipe lines and **construction** shall be as per IS:778 (for size up to 40 mm) and IS:14846 (for sizes above 40 mm) except **for valve spindle movement**. Valves shall be of rising spindle type and of PN 1.6 class
- 7.03.10 Gate Valves shall be provided with the following :
- (a) Hand wheel.
  - (b) Position indicator.
  - (c) Locking facility (where necessary).
- 7.03.11 Gate valves shall be provided with back seating bush to facilitate gland removal during full open condition.

- 7.03.12 Globe valves shall be provided with contoured plug to facilitate regulation and control of flow. All other requirements should generally follow those of gate valve.
- 7.03.13 Non-return valves shall be swing check type. Valves will have a permanent "arrow" inscription on its body to indicate direction of flow of the fluid. These valves shall generally conform to IS:5312.
- 7.03.14 Whenever any valve is found to be so located that it cannot be approached manually from the nearest floor/gallery/platform hand wheel with floor stand or chain operator shall be provided for the same.
- 7.03.15 Valves below 50 mm size shall have screwed ends while those of 50 mm and higher sizes shall have flanged connections.

7.03.14 **Basket Strainer**

- a) Basket strainers shall be of 30mesh and have the following materials of construction :
- Body: Fabricated mild steel as per IS:2062 (Tested Quality).  
Strainer Wires: stainless steel (AISI : 316), 30 SWG, suitably reinforced.
- b) Inside of basket body shall be protected by two (2) coats of heavy duty bitumastic paint.
- c) Strainers shall be Simplex design. Suitable vent and drain connections with valves shall be provided.
- d) Screen open area shall be at least 4 times pipe cross sectional area at inlet.
- e) Pressure drop across strainer in clean condition shall not exceed **1.5 MWC at 410M3/hr (for 765kV/400kV substations) and 1 MWC at 273M3/hr flow (for 220kV & 132kV substations)**. Pressure drop test report of strainer of same design shall be furnished.

7.03.15 **Y-type On-line Strainer**

Body shall be constructed of mild steel as per IS:2062 (tested quality). Strainer wires shall be of stainless steel AISI:316, 30 SWG, 30 mesh.

Blowing arrangement shall be provided with removable plug at the outlet. Screen open area shall be atleast 4 times pipe cross-sectional area at inlet.

Pressure drop test report of strainer of same design shall be furnished.

7.03.16 **Hydrant Valve (Outdoor) and Indoor Hydrant Valves (Internal**

### **Landing Valves).**

The general arrangement of outdoor stand post assembly, consisting of a column pipe and a hydrant valve with a quick coupling end shall be as per TAC requirement.

Materials of construction shall be as follows :

- |                              |   |
|------------------------------|---|
| a) Column pipe               | M.S. IS:1239 med. grade.                          |
| b) Hydrant Valve             |   |
| i) Body                      | <b>Stainless steel.</b>                           |
| ii) Trim                     | Leaded tin bronze as per IS:318, Grade-LTB 2.     |
| iii) Hand Wheel              | Cast Iron as per IS:210, Grade FG:200.            |
| iv) Washer, gasket, etc.     | Rubber as per IS:638.                             |
| v) Quick coupling connection | Leaded tin bronze as per IS:318, Grade-LTB 2.     |
| vi) Spring                   | Phosphor Bronze as per IS:7608.                   |
| vii) Cap and chain           | Leaded tin bronze as per IS:318, Grade-LTB etc.2. |

The general design of hydrant valve shall conform to IS:5290.

### **7.03.17 Hoses, Nozzles, Branch pipes and Hose boxes**

- (a) Hose pipes shall be of reinforced rubber-lined canvas construction as per type A of IS:636 with nominal size of 63 MM (2 1/2") and lengths of 15 metre or 7.5 metre, as indicated elsewhere. All hoses shall be ISI marked.
- (b) Hosepipes shall be capable of withstanding an internal water pressure of not less than 35.7 kg/cm<sup>2</sup> without bursting. It must also withstand a working pressure of 8.5 kg/cm<sup>2</sup> without undue leakage or sweating.
- (c) Each hose shall be fitted with instantaneous spring lock type couplings at both ends. Hose shall be fixed to the coupling ends by copper rivets and the joint shall be reinforced by 1.5 mm galvanised mild steel wires and leather bands.

- (d) Branch pipes shall be constructed of copper and have rings of leaded tin bronze (as per IS:318 Grade-2) at both ends. One end of the branch pipe will receive the quick coupling while the nozzles will be fixed to the other end.
- (e) Nozzles shall be constructed of leaded tin bronze as per IS:318, Grade-2.
- (f) Suitable spanners of approved design shall be provided in adequate numbers for easy assembly and dismantling of various components like branch pipes, nozzles, quick coupling ends etc.
- (g) Hose pipes fitted with quick coupling ends, branch pipes, nozzles spanner etc. will be kept in a hose box, which will be located near point of use. The furnished design must meet the approval of Tariff Advisory Committee.
- (h) All instantaneous couplings, as mentioned under clause Nos.3.03.19, 3.03.20 and 3.03.21 above shall be of identical design (both male and female) so that any one can be interchanged with another. One male, female combination shall get locked in by mere pushing of the two halves together but will provide leak tightness at a pressure of 8 kg/cm<sup>2</sup> of water. Designs employing screwing or turning to have engagement shall not be accepted.

#### 7.04.00 **Fabrication & Erection**

7.04.01 The contractor shall fabricate all the pipe work strictly in accordance with the related approved drawings.

#### 7.04.02 **End Preparation**

- (a) For steel pipes, end preparation for butt welding shall be done by machining.
- (b) Socket weld end preparation shall be sawing/machining.
- (c) For tees, laterals, mitre bends, and other irregular details cutting templates shall be used for accurate cut.

#### 7.04.03 **Pipe Joints**

- (a) In general, pipes having sizes over 25 mm shall be joined by butt welding. Pipes having 25 mm size or less shall be joined by socket welding/screwed connections. Galvanised pipes of all sizes shall have screwed joints. No welding shall be permitted on GI pipes. Screwed joints shall have tapered threads and shall be assured of leak tightness without using any sealing compound.
- (b) Flanged joints shall be used for connections to vessels, equipment,

flanged valves and also on suitable straight lengths of pipe line of strategic points to facilitate erection and subsequent maintenance work.

#### 7.04.04 **Overground Piping**

- (a) Piping to be laid overground shall be supported on pipe rack/supports. Rack/supports details shall have to be approved by Employer/Engineer.
- (b) Surface of overground pipes shall be thoroughly cleaned of mill scale, rust etc. by wire brushing. Thereafter one (1) coat of **red oxide primer** shall be applied. Finally two (2) coats of synthetic enamel paint of approved colour shall be applied.

#### 7.04.05 **Buried Pipe Lines**

- (a) Pipes to be buried underground shall be provided with protection against soil corrosion by coating and wrapping with two coats of coal tar hot enamel paint and two wraps of reinforced fibre glass tissue. The total thickness of coating and wrapping shall not be less than 3 mm. Alternatively corrosion resistant tapes can also be used for protection of pipes against corrosion.
- (b) Coating and wrapping and holiday testing shall be in line with IS:10221.
- (c) Buried pipelines shall be laid with the top of pipe one meter below ground level.
- (d) At site, during erection, all coated and wrapped pipes shall be tested with an approved Holiday detector equipment with a positive signalling device to indicate any fault hole breaks or conductive particle in the protective coating.

#### 7.05.00 **General Instruction for Piping Design and Construction**

7.05.01 While erecting field run pipes, the contractor shall check, the accessibility of valves, instrument tapping points, and maintain minimum headroom requirement and other necessary clearance from the adjoining work areas.

7.05.02 Modification of prefabricated pipes, if any, shall have to be carried out by the contractor at no extra charge to the Employer.

#### 7.05.03 **Welding**

- (i) Welding shall be done by qualified welders only.

- (ii) Before welding, the ends shall be cleaned by wire brushing, filing or machine grinding. Each weld-run shall be cleaned of slag before the next run is deposited.
- (iii) Welding at any joint shall be completed uninterrupted. If this cannot be followed for some reason, the weld shall be insulated for slow and uniform cooling.
- (iv) Welding shall be done by manual oxyacetylene or manual shielded metal arc process. Automatic or semi-automatic welding processes may be done only with the specific approval of Employer/ Consultant.
- (v) As far as possible welding shall be carried out in flat position. If not possible, welding shall be done in a position as close to flat position as possible.
- (vi) No backing ring shall be used for circumferential butt welds.
- (vii) Welding carried out in ambient temperature of 5°C or below shall be heat-treated.
- (viii) Tack welding for the alignment of pipe joints shall be done only by qualified welders. Since tack welds form part of final welding, they shall be executed carefully and shall be free from defects. Defective welds shall be removed prior to the welding of joints.

Electrodes size for tack welding shall be selected depending upon the root opening.

- (ix) Tacks should be equally spaced as follows :
  - for 65 NB and smaller pipes : 2 tacks
  - for 80 NB to 300 NB pipes : 4 tacks
  - for 350 NB and larger pipes : 6 tacks
- (x) Root run shall be made with respective electrodes/filler wires. The size of the electrodes/filler wires. The size of the electrodes shall not be greater than 3.25 mm (10 SWG) and should preferably be 2.3 mm (12 SWG). Welding shall be done with direct current values recommended by the electrode manufacturers.
- (xi) Upward technique shall be adopted for welding pipes in horizontally fixed position. For pipes with wall thickness less than 3 mm, oxyacetylene welding is recommended.

- (xii) The root run of butt joints shall be such as to achieve full penetration with the complete fusion of root edges. The weld projection shall not exceed 3 mm inside the pipe.
- (xiii) On completion of each run craters, weld irregularities, slag etc. shall be removed by grinding or chipping.
- (xiv) Fillet welds shall be made by shielded metal arc process regardless of thickness and class of piping. Electrode size shall not exceed 10 SWG. (3.25 mm). At least two runs shall be made on socket weld joints.

#### 7.06.00 **Tests at Works**

##### 7.06.01 **Pipes**

- (i) Mechanical and chemical tests shall be performed as required in the codes/standards.
- (ii) All pipes shall be subjected to hydrostatic tests as required in the codes/standards.
- (iii) 10% spot Radiography test on welds of buried pipes shall be carried out as per ASME VIII.

##### 7.06.02 **Valves**

- (i) Mechanical and chemical tests shall be conducted on materials of the valve as required in the codes/standards.
- (ii) All valves shall be tested hydrostatically for the seat as well as required in the code/standards for a period of ten minutes.
- (iii) Air test shall be conducted to detect seat leakage.
- (iv) Visual check on the valve and simple operational test in which the valve will be operated thrice from full open to full close condition.
- (v) No repair work on CI valve body, bonnet or wedge shall be allowed.

##### 7.06.03 **Strainers**

- (i) Mechanical and chemical tests shall be conducted on materials of the strainer.
- (ii) Strainers shall be subjected to a hydrostatic test pressure of 1.5 times the design pressure or 10 kg/cm<sup>2</sup>g whichever is higher for a period of one hour.

7.06.04 **Hydrant valves and Indoor Hydrant Valves (Internal Landing Valves)**

- (i) The stand post assembly along with the hydrant valve (valve being open and outlet closed) shall be pressure tested at a hydrostatic pressure of 21 kg/cm<sup>2</sup>g to detect any leakage through defects of casting.
- (ii) Flow test shall be conducted on the hydrant valves at a pressure of 7 kg/cm<sup>2</sup>g and the flow through the valve shall not be less than 900 litres/min.
- (iii) Leak tightness test of the valve seat shall be conducted at a hydrostatic test pressure of 14 kg/cm<sup>2</sup>g.

7.06.05 **Hoses, Nozzles, Branch Pipes and Hose Boxes**

Reinforced rubber-lined canvas hoses shall be tested hydrostatically. Following tests shall be included as per IS:636.

- a) Hydrostatic proof pressure test at 21.4 kgf/cm<sup>2</sup>g
- b) Internal diameter

The branch pipe, coupling and nozzles shall be subjected to a hydrostatic test pressure of 21 kg/cm<sup>2</sup>g for a period of 2<sup>1</sup>/<sub>2</sub> minutes and shall not show any sign of leakage or sweating.

Dimensional checks shall be made on the hose boxes and nozzle spanners.

8.00.00 **AIR VESSELS**

8.01.00 Air vessels shall be designed and fabricated of mild steel as class-II vessels as per IS:2825 for a pressure of 14kg/cm<sup>2</sup> and shall be minimum 3 m<sup>3</sup> capacity.

8.02.00 Inside surface of the tank shall be protected by anti-corrosive paints/coatings/linings as required.

8.03.00 Outside surfaces of the vessels shall be provided with one (1) coat of red lead primer with two (2) coats of synthetic enamel paint of approved colour and characteristics.

8.04.00 **Tests & Inspection**

8.04.01 Air vessels shall be hydraulically tested at 21kg/cm<sup>2</sup> for a period not less than one (1) hour.

8.04.02 All materials used for fabrication shall be of tested quality and test

certificates shall be made available to the Owner.

8.04.03 Welding procedure and Welder's qualification tests will be carried out as per relevant IS Standard.

8.04.04 NDE tests, which will include 100% Radiography on longitudinal seams and spot Radiography for circumferential seams, for pressure vessel will be carried out.

#### 9.00.00 **HEAT DETECTORS/FIRE DETECTORS AND SPRAY NOZZLES**

##### 9.00.01 **Intent of Specification**

This specification lays down the requirements of the smoke detectors, heat detectors and spray nozzles for use in various sub-systems of the fire protection system.

##### 9.00.02 **Codes and Standards**

All equipment supplied shall conform to internationally accepted codes and standards. All equipment offered by Bidders should be TAC approved or have been in use in installations which have been approved by TAC.

##### 9.01.00 **Heat Detectors, Quartzoid bulb type. (Used in HVW spray system)**

- a) Heat detectors shall be of any approved and tested type. Fusible chemical pellet type heat detectors are however not acceptable.
- b) Temperature rating of the heat detector shall be selected by the Bidder taking into consideration the environment in which the detectors shall operate. Minimum set point shall, however, be 79°C.
- c) Heat detectors shall be guaranteed to function properly without any maintenance work for a period of not less than twenty five (25) years.
- d) The heat detectors shall be mounted on a pipe network charged with water at suitable pressure. On receipt of heat from fire, the heat detector will release the water pressure from the network. This drop in water pressure will actuate the Deluge valve.

##### 9.02.00 **HVW Spray Nozzles (Projectors)**

High velocity water spray system shall be designed and installed to discharge water in the form of a conical spray consisting of droplets of water travelling at high velocity which shall strike the burning surface with sufficient impact to ensure the formation of an emulsion. At the same time the spray shall efficiently cut off oxygen supply and provide

sufficient cooling. Integral non-ferrous strainers shall be provided in the projectors ahead of the orifice to arrest higher size particle, which are not allowed to pass through the projectors.

**9.03.00 Fire Detectors (Used in fire detection and alarm system)**

9.03.01 Fire detectors shall be approved by FOC-London or similar international authorities.

9.03.02 Both smoke and heat type fire detectors shall be used. Bidder shall clearly indicate the mode of operation of detectors in his proposal.

9.03.03 The set point shall be selected after giving due consideration for ventilating air velocity and cable insulation.

9.03.04 Fire detectors shall be equipped with an integral L.E.D. so that it shall be possible to know which of the detectors has been operated. The detectors, which are to be placed in the space above the false ceiling or in the floor void shall not have the response indicators on the body but shall be provided with remote response indicators.

9.03.05 Approval from Department of Atomic Energy (DAE), Government of India shall be made available for ionisation type smoke detectors. All accessories required to satisfy DAE shall also be included in the scope of supply.

9.03.06 Fire detectors shall be guaranteed to function properly without any maintenance work for a period of not less than ten (10) years.

**10.00.00 PORTABLE AND WHEEL/ TROLLEY MOUNTED FIRE EXTINGUISHERS**

10.00.01 This specification lays down the requirement regarding fire extinguishers of following types :

Portable fire extinguishers.

- a) Pressurised water type.
- b) Dry chemical powder type
- c) Carbon Dioxide type

Wheel/ Trolley mounted fire extinguishers.

- a) Mechanical foam type

10.00.02 All the extinguishers offered by the Bidder shall be of reputed make and shall be ISI marked.

#### 10.01.00 **Design and Construction**

- 10.01.01 All the portable extinguishers shall be of freestanding type and shall be capable of discharging freely and completely in upright position.
- 10.01.02 Each extinguisher shall have the instructions for operating the extinguishers on its body itself.
- 10.01.03 All extinguishers shall be supplied with initial charge and accessories as required.
- 10.01.04 Portable type extinguishers shall be provided with suitable clamps for mounting on walls or columns.
- 10.01.05 All extinguishers shall be painted with durable enamel paint of fire red colour conforming to relevant Indian Standards.
- 10.01.06 Pressurisation of water type fire extinguishers shall either be done by compressed air or by using gas cartridge. **Both constant air pressure and the gas pressure type shall conform to IS 15683:2006.** Both these extinguishers shall be ISI marked.
- 10.01.07 **Dry chemical powder type portable extinguisher shall conform to IS 15683:2006.**
- 10.01.08 **Carbon Dioxide type portable extinguisher shall conform to IS:15683:2006 and Carbon Dioxide type trolley mounted extinguisher shall conform to IS:2878.**
- 10.01.09 Wheel/ trolley mounted fire extinguishers of 50 litre capacity Mechanical foam type shall conform to IS:13386

#### 10.02.00 **Tests and Inspection**

- 10.02.01 A performance demonstration test at site of five (5) percent or one (1) number whichever is higher, of the extinguishers shall be carried out by the Contractor. All consumable and replaceable items require for this test would be supplied by the Contractor without any extra cost to Employer.
- 10.02.02 Performance testing of extinguisher shall be in line of applicable Indian Standards. In case where no Indian Standard is applicable for a particular type of extinguisher, the method of testing shall be mutually discussed and agreed to before placement of order for the extinguishers.

#### 10.03.00 **Painting**

Each fire extinguisher shall be painted with durable enamel paint of fire red colour conforming to relevant Indian Standards.

## 11.00.00 INSTRUMENTS

### 11.00.01 Intent of Specification

The requirements given in the sub-section shall be applicable to all the instruments being furnished under this specification.

11.00.02 All field mounted instruments shall be weather and dust tight, suitable for use under ambient conditions prevalent in the subject plant. All field mounted instruments shall be mounted in suitable locations where maximum accessibility for maintenance can be achieved.

### 11.01.00 Local Instruments

Pressure/ Differential Gauges & Switches.

11.01.01 The pressure sensing elements shall be continuous 'C' bourdon type.

11.01.02 The sensing elements for all gauges/switches shall be properly aged and factory tested to remove all residual stresses. They shall be able to withstand atleast twice the full scale pressure/vacuum without any damage or permanent deformation.

11.01.03 For all instruments, connection between the pressure sensing element and socket shall be braced or hard soldered.

11.01.04 Gauges shall be of 150 mm diameter dial with die-cast aluminium, stoved enamel black finish case, aluminium screwed ring and clear plastic crystal cover glass. Upper range pointer limit stop for all gauges shall be provided.

11.01.05 All gauges shall be with stainless steel bourdon having rotary geared stainless steel movements.

11.01.06 Weatherproof type construction shall be provided for all gauges. This type of construction shall be fully dust tight, drip tight, weather resistant and splash proof with anti-corrosive painting conforming to NEMA- 4.

11.01.07 All gauges shall have micrometer type zero adjuster.

11.01.08 Neoprene safety diaphragm shall be provided on the back of the instruments casing for pressure gauges of ranges 0-10 Kg/cm<sup>2</sup> and above.

11.01.09 Scales shall be concentric, white with black lettering and shall be in metric units.

11.01.10 Accuracy shall be  $\pm 1.0$  percent of full range or better.

- 11.01.11 Scale range shall be selected so that normal process pressure is approximately 75 percent of full scale reading. For pressure gauges and pressure switches, the range shall not be less than 0 -16 Kg/cm<sup>2</sup>
- 11.01.12 All gauges shall have 1/2 inch NPT bottom connection.
- 11.01.13 All instruments shall conform to IS: 3624 - 1966.
- 11.01.14 All instruments shall be provided with 3 way gauge isolation valve or cock. Union nut, nipple and tail pipe shall be provided wherever required.
- 11.01.15 Switch element contact shall have two (2) NO and two (2) NC contacts rated for 240 Volts, 10 Amperes A.C. or 220 Volts, 5 Amperes D.C. Actuation set point shall be adjustable throughout the range. ON-OFF differential (difference between switch actuation and de-actuation pressures) shall be adjustable. Adjustable range shall be suitable for switch application.
- 11.01.16 Switches shall be sealed diaphragm, piston actuated type with snap action switch element. Diaphragm shall be of 316 SS.

11.01.18 Necessary accessories shall be furnished.

#### 11.02.00 **Timers**

11.02.01 The timers shall be electro-mechanical type with adjustable delay on pick-up or reset as required.

11.02.02 Each timer shall have two pairs of contacts in required combination of NO and NC.

#### 11.03.00 **Level Gauges/Indicator/Switches**

##### 11.03.01 **Level Gauges**

- i) Gauge glasses shall be used for local level indication wherever shown in the flow diagram.
- ii) Gauge glasses, in general, shall be flag glass type with bolted cover. Body and cover material shall be of carbon steel with rubber lining.
- iii) Level coverage shall be in accordance with operating requirements. Maximum length of a single gauge glass shall not exceed 1.4 M. Should a larger gauge glass be required, multiple gauges of preferably equal length shall be used with 50 mm overlap in visibility.
- iv) Reflex type gauge glasses shall be used for colourless liquids and

transparent type gauge glasses shall be used for all liquids having colour.

- v) Each gauge glass shall be complete with a pair of offset valves. Valves shall have union bonnet, female union level connection, flanged tank connection, and vent and drain plug.
- vi) Offset valves shall have corrosion resistant ball-check to prevent fluid loss in the event of gauge glass breakage. Valve body shall have a working pressure of 200 percent of the maximum static pressure at the maximum process fluid temperature. Valve body materials shall be of carbon steel with rubber lining.

#### 11.03.02 **Level Indicators**

- i) Float type mechanical level gauges with linear scale type indicator shall be offered for measuring level of tanks wherever shown in the flow diagram.
- ii) AISI-316 stainless steel float, guide rope and tape shall be used. Housing shall be of mild steel painted with anti-corrosive painting.
- iii) The scale indicator shall be provided at a suitable height for ease of reading.
- iv) Accuracy shall be + 1% of scale range or better.

#### 11.03.03 **Level Switches**

- i) Level switches shall be of ball float operated magnetic type complete with cage.
- ii) Materials of construction shall be suitable for process and ambient conditions. The float material shall be AISI-316 stainless steel.
- iii) Actuating switches shall be either hermetically sealed mercury type or snap acting micro-switches. Actuation set point shall be adjustable. ON-OFF differential (difference between switch actuation and de-actuation levels) shall be adjustable. Adjustable range shall be suitable for switch application. All switches shall be repeatable within + 1.0 percent of liquid level change required to activate switch. Contacts shall be rated for 50 watts resistive at 240 V A.C. Number of contacts shall be two NO and two NC for each level switch.

#### 11.04.00 **Solenoid Valves**

11.04.01 The body of the valves shall be Forged brass or stainless steel.

11.04.02 The coil shall be continuous duty, epoxy moulded type Class-F, suitable for high temperature operation.

11.04.03 The enclosure shall be watertight, dust-tight and shall conform to NEMA-4 Standard.

11.04.04 The valves shall be suitable for mounting in any position.

**11.05.00 Switches, Lamps, Meters Etc.**

All electrical components on the panel namely push buttons, switches, lamps, meters etc. shall meet the requirements of sub-section Electrical enclosed with the specification.

11.06.00 All local instruments shall be inspected by Employer/Consultant as per the agreed quality plan.

11.07.00 Makes of control panel and local instruments, accessories shall be as per Employer's approval.

**12.00.00 ELECTRIC MOTORS**

**12.01.00 General**

12.01.01 This clause covers the requirements of three phase squirrel cage induction motors and single-phase induction motors.

12.01.02 The motors to be furnished, erected and commissioned as covered under this specification shall be engineered, designed, manufactured, erected, tested as per the requirements specified herein. These requirements shall however be read along with the requirements of the respective driven equipment being supplied under the specification of which this specification forms a part.

12.01.03 The motor supplied under this specification shall conform to the standards specified in GTR.

12.01.04 Terminal point for all motors supplied under this specification shall be at the respective terminal boxes.

12.01.05 Materials and components not specifically stated in this specification but are necessary for satisfactory operation of the motor shall be deemed to be included in the scope of supply of this specification.

12.01.06 Notwithstanding anything stated in this motor specification, the motor has to satisfy the requirement of the mechanical system during normal and abnormal conditions. For this the motor manufacturer has to co-ordinate with the mechanical equipment supplier and shall ensure that the motor being offered meets the requirements.

**12.02.00 Codes & Standards**

- 12.02.21 The design, manufacture, installation and performance of motors shall conform to the provisions of latest Indian Electricity Act and Indian Electricity Rules. Nothing in these specifications shall be construed to relieve the Contractor of his responsibility.
- 12.02.22 In case of contradiction between this specifications and IS or IEC, the stipulations of this specification shall be treated as applicable.
- 12.02.23 National Electrical code for hazardous location and relevant NEMA standard shall also be applicable for motors located in hazardous location.

### 12.03.00 **Design Features**

#### 12.03.01 **Rating and type**

- (i) The induction motors shall be of squirrel cage type unless specified otherwise.
- (ii) The motors shall be suitable for continuous duty in the specified ambient temperature.
- (iii) The MCR KW rating of the motors for 50°C ambient shall not be less than the power requirement imposed at the motor shaft by the driven equipment under the most onerous operation conditions as defined elsewhere, when the supply frequency is 51.5 Hz (and the motor is running at 103% of its rated speed).
- (iv) Motors shall be capable of giving rated output without reduction in the expected life span when operated continuously in the system having the following particulars :
  - a) Rated terminal voltage
    - From 0.2 to 200 KW      415V (3 Phase, solidly earthed)
    - Below 0.2 KW            240 V (1 Phase, solidly earthed)Variation in voltage  $\pm 6\%$ .
  - b) Frequency      50 Hz  $\pm 3\%$ .
  - c) Any combination of (a) & (b)

#### 12.03.02 Enclosure

Motors to be installed outdoor and semi-outdoor shall have hose proof enclosure equivalent to IP-55 as per IS: 4691. For motors to be installed indoor, the enclosure shall be dust proof equivalent to IP-54 as

per IS: 4691.

#### 12.03.03 **Cooling method**

Motors shall be TEFC (totally enclosed fan cooled) type.

#### 12.03.04 **Starting requirements**

##### (i) **Induction motor**

- a) All induction motors shall be suitable for full voltage direct on-line starting. These shall be capable of starting and accelerating to the rated speed alongwith the driven equipment without exceeding the acceptable winding temperature even when the supply voltage drops down to 80% of the rated voltage.
- b) Motors shall be capable of withstanding the electro-dynamic stresses and heating imposed if it is started at a voltage of 110% of the rated value.
- c) The starting current of the motor at rated voltage shall not exceed six (6) times the rated full load current subject to tolerance as given in IS : 325.
- d) Motors when started with the driven equipment imposing full starting torque under the supply voltage condition specified under Clause 12.03.01 (iv) (a) shall be capable of withstanding at least two successive starts with coasting to rest between starts and motor initially at the rated load operating temperature. The motors shall also be suitable for three equally spread starts per hour, the motor initially at a temperature not exceeding the rated operating temperature.
- e) The locked rotor withstand time under hot condition at 110% of rated voltage shall be more than the starting time with the driven equipment at minimum permissible voltage (clause 12.03.04 (i) (a) by at least two seconds or 15% of the accelerating time whichever is greater. In case it is not possible to meet the above requirement the Bidder shall offer centrifugal type speed switch mounted on the motor shaft which shall remain closed for speeds lower than 20% and open for speeds above 20% of the rated speed. The speed switch shall be capable of withstanding 120% of the rated speed in either direction of rotation.

#### 12.03.05 **Running requirements**

- (i) When the motors are operating at extreme condition of voltage and frequency given under clause no.12.03.01 (iv) the maximum permissible temperature rise over the ambient temperature of 50°C shall be within the limits specified in IS : 325 after adjustment due

to increase ambient temperature specified herein.

- (ii) The double amplitude of motor vibration shall be within the limits specified in IS: 4729. Vibration shall also be within the limits specified by the relevant standard for the driven equipment when measured at the motor bearings.
- (iii) All the induction motors shall be capable of running at 80% of rated voltage for a period of 5 minutes with rated load commencing from hot condition.
- (iv) Induction motors shall be so designed as to be capable of withstanding the voltage and torque stresses developed due to the difference between the motor residual voltage and incoming supply voltage during fast changeover of buses. The necessary feature incorporated in the design to comply with this requirement shall be clearly indicated in the proposal.
- (v) Motors shall be capable of developing the rated full load torque even when the supply voltage drops to 70% of rated voltage. Such operation is envisaged for a period of one second. The pull out torque of the induction motors to meet this requirement shall not be less than 205% of full load torque.
- (vi) The motors shall be capable of withstanding for 10 seconds without stalling or abrupt change in speed (under gradual increase of torque) an excess torque of 60 percent of their rated torque, the voltage and frequency being maintained at their rated value.
- (vii) Guaranteed performance of the motors shall be met with tolerances specified in respective standards.

#### 12.04.00 **Construction Features**

##### 12.04.01 **Stator**

###### (i) **Stator frame**

The stator frames and all external parts of the motors shall be rigid fabricated steel or of casting. They shall be suitably annealed to eliminate any residual stresses introduced during the process of fabrication and machining.

###### (ii) **Stator core**

The stator laminations shall be made from suitable grade magnetic sheet steel varnished on both sides. They shall be pressed and clamped adequately to reduce the core and teeth vibration to minimum.

###### (iii) **Insulation and winding**

All insulated winding conductor shall be of copper. The overall motor winding insulation for all 415 volts motors shall be of epoxy thermosetting type i.e., class 'F' but limited to class-B operating from temperature rise consideration. Other motors may be of conventional class-B type. The windings shall be suitable for successful operation in hot, humid, tropical climate with the ambient temperature of 50oC.

#### 12.04.02 **Rotor**

- (i) Rotors shall be so designed as to keep the combined critical speed with the driven equipment away from the running speed by atleast 20%.
- (ii) Rotors shall also be designed to withstand 120% of the rated speed for 2 minutes in either direction of rotation.

#### 12.04.03 **Terminal box leads**

- (i) For motors of 415 Volts and below a single terminal box may be provided for power and accessories leads.
- (ii) Terminal boxes shall be of weatherproof construction designed for outdoor service. To eliminate entry of dust and water, gaskets of neoprene or approved equivalent shall be provided at cover joints and between box and motor frame.
- (iii) Terminal box shall be suitable for top and bottom entry of cables.
- (iv) Unless otherwise approved, the terminal box shall be capable of being turned through 360o in steps in 90o.
- (v) The terminals shall be complete with all accessories for connecting external cables. They shall be designed for the current carrying capacity and shall ensure ample phase to phase to ground clearances.
- (vi) Suitable tinned brass compression type cable glands and cable lugs shall be supplied by the Contractor to match Employer's cable.
- (vii) Terminal box for single core cable shall be of non- magnetic material.
- (viii) Marking of all terminals shall be in accordance with IS : 4728.

#### 12.04.04 **Rating Plates**

- (i) Rating plates shall be provided for all motors giving the details as called for in IS:325 (for three phase squirrel cage induction

motors).

- (ii) In addition to above, the rating plate shall indicate the following :
  - a) Temperature rise in oC under normal working conditions.
  - b) Phase sequence corresponding to the direction of rotation for the application.
  - c) Bearing identification number (in case of ball/ roller bearing) and recommended lubricants.

#### 12.04.05 **Other Constructional Features**

- (i) Two independent earthing points shall be provided on opposite sides of the motor for bolted connection of Employer's earthing conductor to be specified to the successful Bidder.
- (ii) Motor weighing more than 25 kg. shall be provided with eyebolts, lugs or other means to facilitate lifting.

#### 12.05.00 **Paint and Finish**

12.05.01 Motor external parts shall be finished and painted to produce a neat and durable surface, which would prevent rusting and corrosion. The equipment shall be thoroughly degreased, all sharp edges and scales removed and treated with one coat of primer and two coats of grey enamel paint.

12.05.02 Motor fans shall also be painted to withstand corrosion.

12.05.03 All fasteners used in the construction of the equipment shall be either of corrosion resistant material or heavy cadmium plated.

12.05.04 Current carrying fasteners shall be either of stainless steel or high tensile brass.

#### 12.06.00 **Tests at Manufacturers Works**

12.06.01 Motors shall be subject to routine tests in accordance with IS : 325 & IS : 4029 standards.

12.06.02 In addition, the following tests shall also be carried out :

- a) 20% over speed test for 2 minutes on all rotors.
- b) Measurement of vibration.
- c) Measurement of noise level.

- d) Phase sequence and polarity checks relative to mechanical rotation.

#### 12.06.03 **Tests after installation at site**

- (i) After installation and commissioning at site, the motors alongwith the driven equipment shall be subject to tests to ascertain their conformity with the requirement of this specification and those of the driven equipment specification and the performance data quoted by the Bidder.
- (ii) In case of non-conformity of the motor with these specifications and performance requirement, the Engineer may at his discretion reject or ask for necessary rectification/replacement as detailed in general Terms and Conditions of Contract (GCC) Volume-I.

#### 13.00.00 **BATTERY & BATTERY CHARGERS**

This clause covers the design, performance, manufacturing, construction features and testing of Battery and Battery charger used primarily for starting the diesel engine driving the fire water pumps. Battery Chargers shall be housed in Diesel Engine Panel.

##### 13.01.00 **General Information**

13.01.01 The equipment specified hereinafter are required for starting the diesel engines and other operation of the plant as required.

13.01.02 For each diesel engine there shall be two (2) sets of Battery and two (2) sets of Battery Charger.

13.01.03 The D.C. voltage shall be obtained normally after necessary rectification by battery charger. The Battery Charging system shall be capable of meeting the following requirements :

13.01.04 Float charging the Battery.

13.01.05 Boost Charging the Battery.

13.01.06 The battery shall be large enough to crank the engine **3** times without charging in between and without getting drained to an extent which will affect its life.

13.01.07 The Bidder shall indicate the battery voltage and battery capacity in Ampere- Hour at ten (10) hour discharge rate. The battery voltage at any time during operation shall not be less than the minimum voltage required for operation of the D.C. loads.

##### 13.02.00 **General Design**

The Battery shall be located indoor

#### 13.02.01 **Battery**

- (i) The cells shall be lead-acid type. The Battery shall be automotive type.
- (ii) The cells shall be sealed in type with anti-splash type vent plug.
- (iii) The cell terminal posts shall be provided with connector bolts and nuts, effectively coated with lead to prevent corrosion. Lead or lead coated copper connectors shall be furnished to connect up cells of battery set.
- (iv) Positive and Negative terminal posts shall be clearly and indelibly marked for easy identification.
- (v) The electrolyte shall be of battery grade Sulphuric Acid conforming to IS : 226-2962. Water for storage batteries conforming to IS : 1069 shall be used in the preparation of the electrolyte.

#### 13.02.02 **Battery Charger**

- (i) The Bidder shall furnish the battery charging scheme complete with all necessary accessories such as transformers, switches, fuses, starters, contactors, diodes, ammeters, voltmeters and other devices as required for trouble free operation. All devices and equipment shall conform to relevant Indian Standard or shall be Superior to it.
- (ii) The scheme of the battery charger shall be such that the battery can be charged automatically as well as manually.
- (iii) The boost charger shall have sufficient capacity to restore a fully discharged Battery to a state of full charge in eight (8) hours with some spare margin over maximum charging rate. Suitable provision shall be kept so that, for a particular engine, any of the two (2) charger units can be used for charging any of the two (2) batteries.
- (iv) The instruments, switches and lamps shall be flush/semi-flush mounted on the front panel. Name plate of approved type shall be provided for each of these equipment.
- (v) The panel shall be complete with internal wiring and input-output terminal block. Terminal blocks shall be clip on type of suitable rating. All equipment and wire terminals shall be identified by symbols corresponding to applicable schematic/wiring diagram.

- (vi) Space heaters of adequate capacity shall be provided to prevent moisture condensation in the panel.

#### 13.03.00 **Testing**

13.03.01 The Battery Charger shall also be subjected to the following tests at manufacturer's works as per IS - 4540

13.03.02 Insulation test.

13.03.03 Connection checking.

13.03.04 Measurement of voltage regulation.

13.03.05 Auxiliary of devices.

13.03.06 Alternating current measurement.

13.03.07 Performance test.

13.03.08 Temperature rise test.

13.03.09 Following acceptance tests shall be carried out in batteries as per IS:1651.

- a) Marking and packing
- b) Verification of dimensions
- c) Test for capacity
- d) Test for voltage during discharge

Battery and battery charger shall be checked for auto charging and providing sufficient power for three consecutive starting kicks to diesel engine within five minutes with A.C. supply switched off.

#### 14.00.00 **CONTROL & ANNUNCIATION PANELS**

##### 14.01.00 **Intent of Specification**

The following requirement shall be applicable to the control and annunciation panels furnished under these specifications.

##### 14.02.00 **General Information**

14.02.01 The equipment specified herein are required for controlling, metering, monitoring and indication of electrical systems of the plant offered.

14.02.02 The selection and design of all the equipment shall be so as to ensure reliable and safe operation of the plant and shall be subjected to approval by the Employer.

14.02.03 The reference ambient temperature outside the panel shall be taken as 50oC and relative humidity 100%.

**14.03.00 Equipment to be Furnished**

Control & annunciation panels shall be furnished complete with all accessories and wiring for safe and trouble free operation of the plant. Details are included in sub-section General.

**14.04.00 Constructional Details**

14.04.01 The panel frames shall be fabricated using suitable mild steel structural sections or pressed and shaped cold-rolled sheet steel of thickness not less than 2.5 mm. Frames shall be enclosed in cold-rolled sheet steel of thickness not less than 1.6 mm. Stiffeners shall be provided wherever necessary.

14.04.02 Panels shall be of free standing type and shall be provided with hinged door with locking arrangement. The access doors, cutest and covers shall be equipped with neoprene/synthetic rubber gaskets (conforming to IS 11149-1984) all around and the latches sufficiently strong to hold them in alignment when closed. The panels to be installed outdoor or semi outdoor shall have a degree of protection of IP:55 and those installed indoor shall have a degree of protection of IP:52 as per IS:13947 Part-1.

14.04.03 If a panel consists of a number of panels, each panel should be mounted side by side and bolted together to form a compact unit, when two panels meet, the joints shall be smooth, close fittings and un-obstructive.

14.04.04 Removable eye bolt or lifting lugs shall be provided on all panels to facilitate easy lifting.

14.04.05 The heights of all operating equipment on the panel shall be between 800 mm to 1600 mm from the finished floor level. The proper supporting arrangement shall be provided by the Contractor.

14.04.06 Cable entries to the panel may be from bottom or top. The cable entry required will be intimated to the successful Bidder. A suitable removable gland plate of 3 mm thick shall be mounted not less than 200 mm above the floor level.

14.04.07 All equipment mounted on the front face of the panels shall be flush or semi-flush type. All equipment shall be so located that their terminal

and adjustment are readily accessible for inspection or maintenance and their removal and replacement can be done without interruption of service to other equipment. The contractor shall submit the panel general arrangement drawings clearly bringing out internal mounting details, dimensions of equipment, clearance between the equipment and the edges of the panel, for approval.

#### 14.05.00 **Name Plates and Labels**

14.05.01 Each panel shall be provided with prominent, engraved identification plates for all front mounted equipment. Panel identification name plate shall be provided at front and rear as required.

14.05.02 All name plates shall be of non-rusting metal or 3 ply lamincold, with white engraved lettering on black background. Inscription and lettering sizes shall be subjected to Employer's approval.

14.05.03 Suitable plastic sticker labels shall be provided for easy identification of all equipment located inside the panel. These labels shall be positioned so as to be clearly visible and shall give the device number, as mentioned in the wiring drawings.

#### 14.06.00 **AC/DC Power Supply**

14.06.02 The Employer will provide one feeder each for AC and DC to the panel. The Contractor shall make for his own arrangements for providing these power supplies to different panels.

14.06.02 The Contractor shall provide suitable isolating switch fuse unit in the control panel for receiving the above incoming AC and DC supplies. Fuse and link shall be provided for isolating of individual circuit without disturbing other circuits.

#### 14.07.00 **Wiring**

14.07.01 All inter panel wiring and connections between panels (if there is group of panels) including all bus wiring for AC & DC supplies shall be provided by the Contractor.

14.07.02 All internal wiring shall be carried out with 1100 V grade, single core, 1.5 square mm or larger stranded copper wires having colour-coded PVC insulation. CT circuits shall be wired with 2.5 square mm copper wires, otherwise similar to the above.

14.07.03 Extra-flexible wire shall be used for wiring to devices mounted on moving parts such as doors.

14.07.04 Spare contacts of auxiliary relays, timers and switches shall be wired out to the terminal blocks as required by the Employer/Engineer at the time of detailed engineering.

#### 14.08.00 **Terminal Blocks**

14.08.01 Terminal Blocks shall be of 650V grade, rated for 10 Amps and in one-piece moulding. It shall be complete with insulating barriers, clip-on-type terminals, and identification strips. Marking on terminal strip shall correspond to the terminal numbering on wiring diagrams. It shall be similar to 'Elmex-Standard' type terminals.

14.08.02 Terminal blocks shall be arranged with at least 100 mm clearance between two sets of terminal block.

14.08.03 The terminal blocks shall have at least 20% spare terminals.

#### 14.09.00 **Grounding**

A continuous copper bus 25 x 3 mm size shall be provided along the bottom of the panel structure. It shall run continuously throughout the length of the panel and shall have provision at both ends for connection to the station grounding grid (25 x 6 mm MS Flat).

#### 14.10.00 **Space Heater and Lighting**

14.10.01 Space heaters shall be provided in the panels for preventing harmful moisture condensation.

14.10.02 The space heaters shall be suitable for continuous operation on 240V AC, 50 Hz, single phase supply and shall be automatically controlled by thermostat. Necessary isolating switches and fuses shall also be provided.

14.10.03 Free standing panel shall have a 240V AC, plug point and a fluorescent light operated by door switch.

#### 14.11.00 **Control and Selector Switches**

14.11.01 Control and selector switches shall be of rotary type, with escutcheon plates clearly marked to show the function and positions.

14.11.02 Control/selector switches shall be spring return or stay put type as per the requirements. Handles of control/selector switches shall be black in colour. Shape and type of handles shall be to the approval of the Employer.

14.11.03 The contact ratings shall be at least the following :

- i) Make and carry continuously      10 Amp.
- ii) Breaking current at 240V DC      1Amp. (Inductive)

iii) Breaking current at 240V DC 5 Amp. at 0.3 p.f. lagging

#### 14.12.00 **Push Buttons**

14.12.01 Push buttons shall be spring return, push to actuate type and rated to continuously carry and break 10A at 240V AC and 0.5A (Inductive) at 220V DC. The push buttons shall have at least 1 NO and 1 NC contact. All contact faces shall be of silver or silver alloy.

14.12.02 All push buttons shall be provided with integral escutcheon plates marked with its function.

14.12.03 The colour of buttons shall be as follows :

Green For motor START, Breaker CLOSE, Valve/ damper OPEN.

Red For motor TRIP, Breaker OPEN, Valve/ damper CLOSE.

Black For all annunciation functions, overload reset and miscellaneous.

14.12.04 Red push buttons shall always be located to the left of green push buttons. In case of clinker grinder etc. the push buttons would be black-red-green from left to right.

#### 14.13.00 **Indicating Lamps**

14.13.01 Indicating lamps shall be of the panel mounting, filament type and of low-watt consumption. Lamps shall be provided with series resistors preferably built-in- the lamps assembly. The lamps shall have escutcheon plates marked with its function, wherever necessary.

14.13.02 Lamp shall have translucent lamp covers of the following colours :

Red for motor OFF, Valve/damper OPEN, Breaker CLOSED.

Green for motor ON, Valve/damper CLOSED, Breaker OPEN.

White for motor AUTO-TRIP.

Blue for all healthy conditions (e.g. control supply, lub oil pressure and also for spring charged).

Amber for all ALARM conditions (e.g. pressure low, over load and also for 'service' and 'Test' position indication).

14.13.03 Bulbs and lamps covers shall be easily replaceable from the front of the panel.

14.13.04 Indicating lamps should be located directly above the associated push

button/control switches. Red lamps shall variably be located to the right of the green lamp. In case a white lamp is also provided, it shall be placed between the red and green lamps. Blue and amber lamps should normally be located above the red and green lamps.

#### 14.14.00 **Fuses**

14.14.01 All fuses shall be of HRC cartridge plug-in-type and shall be of suitable rating, depending upon circuit requirements.

14.14.02 All fuses shall be mounted on fuse carriers, which shall be mounted on fuse-bases.

#### 14.15.00 **Contactors**

14.15.01 Contactors shall be of air break, electromagnetic type rated as per requirement. These shall be of utilisation category AC 3 as per IS:2959.

14.15.02 Operating coils of AC contactors shall be of 240V AC or 220V DC as required. AC contactors shall operate satisfactorily between 85% to 110% of the rated voltage. The Contactor shall not drop out at 70% of the rated voltage.

14.15.03 DC contactors shall have a coil voltage of 220V DC and shall be suitable for satisfactory continuous operation at 80% to 110% of the rated voltage.

#### 14.16.00 **Relays and Timers**

14.16.01 All auxiliary relays & timers shall be of proven design and of reputed make. Contacts of relays and timers shall be of solid silver or silver cadmium oxide or solid silver faced. Timers shall have the provision to adjust the delay on pick-up or reset as required.

14.16.02 All relays and timers shall have at least two NO and two NC contacts.

14.16.03 All relays and timers shall be suitable for 240V AC and 220V DC as required. DC relays shall operate satisfactorily between 70% to 110% and AC relays shall be suitable for voltage variation between 80% to 110%.

#### 14.17.00 **Indication Instruments**

14.17.01 All indicating and integrating meters shall be flush mounted on panel front. The instruments shall be of at least 96 mm square size with 90 degree scales and shall have an accuracy class of 2.0 or better. The covers and cases of instruments and meters shall provide a dust and vermin proof construction.

14.17.02 All instruments shall be compensated for temperature errors and factory

calibrated to directly read the primary quantities. Means shall be provided for zero adjustment removing or dismantling the instruments.

14.17.03 All instruments shall have white dials with black numerals and lettering. Black knife edge pointer with parallax free dials will be preferred.

14.17.04 Ammeters provided on motor feeders shall have a compressed scale at the upper current region to cover the starting current.

#### 14.18.00 **Annunciation System**

14.18.01 The annunciation system shall be complete with all necessary relays, flashers and other accessories required for the proper operation of the equipment and shall be completely solid state. The control circuit shall be mounted on plug-in type glass epoxy printed circuit boards. Audible alarms for the system shall be mounted inside the panel. One set of acknowledge, test and reset push buttons shall be mounted on the panel.

14.18.02 Indications shall be engraved on Acrylic inscription plate window and shall be visible clearly when the indication lamp is lighted (black letters on white background). Each window shall be provided with two lamps.

14.18.03 Audible hooter shall sound when a trouble contact operates and shall continue to sound until the acknowledge button is pressed. In addition to the hooters provided on annunciation panels, a hooter shall be provided outside FFPH which shall sound in any fire alarm condition.

14.18.04 Indication lamps shall flash when trouble contact operates and shall continue flashing until acknowledge button is pressed.

14.18.05 After acknowledge button is pressed, the hooter and flashing shall stop but the indication lamp shall remain lighted.

14.18.06 After trouble is cleared indication lamps shall be ready and shall go off only when reset.

14.18.07 Silencing the hooter in conjunction with one trouble contact shall not stop and hooter sounding if another trouble contact operates.

14.18.08 When test button is pressed, all lamps shall flash and hooter shall sound.

14.18.09 Annunciator systems shall operate on 220V DC Systems.

14.18.10 The annunciation system shall include alarm for AC control system failure (working on DC supply), DC supply failure (working on AC supply) and test facilities for these alarms.

14.18.11 List of annunciations required on the panels has been listed elsewhere.

The Contractor shall also provide additional annunciations if desired by the Employer/Engineer during Vendor drawing review stage and for such additional annunciations no extra charges shall be claimed by the Contractor, if the number of such additions are within 10% of the number stipulated in this specification.

14.18.12 20% spare windows shall be provided on the panel.

#### 14.19.00 **Painting**

14.19.01 **Painting procedure adopted shall conform to requirements given in GTR. The paint thickness shall not be less than 60 microns.** Finished parts shall be coated by peelable compound by spraying method to protect the finished surface from scratches, grease, dirt and oily spots during testing, transportation handling and erection.

#### 14.20.00 **Tests**

14.20.01 Following tests/inspection shall be carried out by the Contractor in the presence of Employer's representative :

##### (A) Factory Tests

1. Compliance with approved drawings, data and specification.
2. Visual check for workmanship.
3. Wiring continuity and functional checks.
4. Calibration of instruments, relays and metres wherever required by inspector.
5. HV test
6. Insulation resistance measurement before and after HV test.

##### (B) Inspection/Testing at site :

1. IR test before and after HV test
2. HV Test
3. Functional Testing.

##### (C)

1. The Fire detection and annunciation panel shall be subjected to functional tests.
2. The Annunciation System shall be routine tested

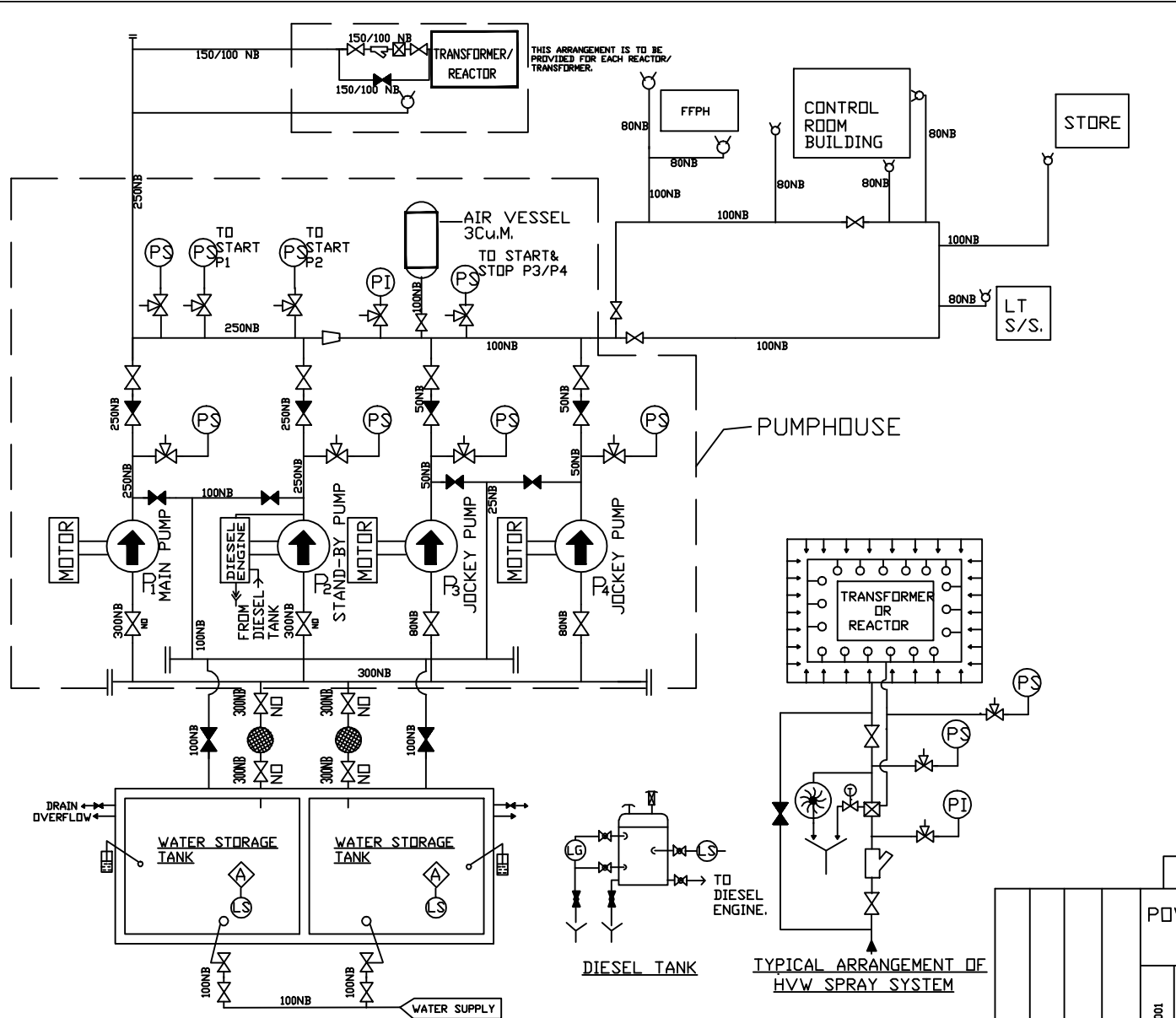

APPENDIX-I  
TO TECHNICAL SPECIFICATION  
FOR FIRE PROTECTION SYSTEM REV.-6

- LEGEND**
- ◇ ALARM
  - ⊗ GATE VALVE NORMALLY OPEN
  - ⊘ GATE VALVE NORMALLY CLOSED
  - ⊗ NON-RETURN VALVE
  - ⊗ GLOBE VALVE NORMALLY OPEN
  - ⊘ GLOBE VALVE NORMALLY CLOSED
  - ⊗ FLOAT OPERATED GATE VALVE
  - ⊗ TEST VALVE
  - ⊗ PRESSURE GAUGE
  - ⊗ PRESSURE SWITCH
  - ⊗ LEVEL GAUGE
  - ⊗ LEVEL SWITCH
  - ⊗ BASKET STRAINER
  - ⊗ FLOAT OPERATED LEVEL GAUGE
  - ⊗ Y-TYPE STRAINER
  - ⊗ WATER MOTOR GONG
  - ⊗ REDUCER
  - ⊗ THREE WAY COCK/ VALVE
  - ⊗ VENT
  - ⊗ DRAIN
  - ⊗ OUT DOOR HYDRANT
  - ⊗ QUARTZOID BULB DETECTOR
  - ⊗ HVW SPRAY NOZZLE
  - ⊗ PUMP
  - ⊗ WATER LINE
  - ⊗ DELUGE VALVE

**NOTES:** 1. THE HYDRANT POINTS FOR TRANSFORMER/ REACTOR SHALL BE LOCATED AT LEAST 20M AWAY FROM THEM.  
2. AS SAFETY MEASURE, A WARNING PLATE SHALL BE PLACED NEAR HYDRANT POINTS FOR TRANSFORMER/ REACTOR TO CLEARLY INDICATE THAT WATER SHALL BE SPRAYED ONLY AFTER ENSURING THAT THE POWER TO THE TRANSFORMER/ REACTOR WHICH IS ON FIRE IS SWITCHED OFF AND THERE ARE NO LIVE PART WITHIN 20 M. DISTANCE OF THE PERSONNEL USING THE HYDRANT.

FOR TENDER PURPOSE ONLY

POWER GRID CORPORATION OF INDIA LIMITED <small>(A GOVERNMENT OF INDIA ENTERPRISE)</small>				PROJECT:	
				765kV AND 400kV SUBSTATION	
APP.D.				TITLE:	
				PIPING & INSTRUMENTATION DIAGRAM FOR HYDRANT & HVW SPRAY SYSTEM.	
22.11.2001	A. JXAVIER	A. JXAVIER	APP.D.	DRG.ND.	REV.
RECOMMENDED	DATE	DRAWN	CHKD.	C/ENGG/STD/FP/1	4
				NTS	Sheet 1 of 1

APPENDIX-II  
TO TECHNICAL SPECIFICATION  
FOR FIRE PROTECTION SYSTEM REV.-6

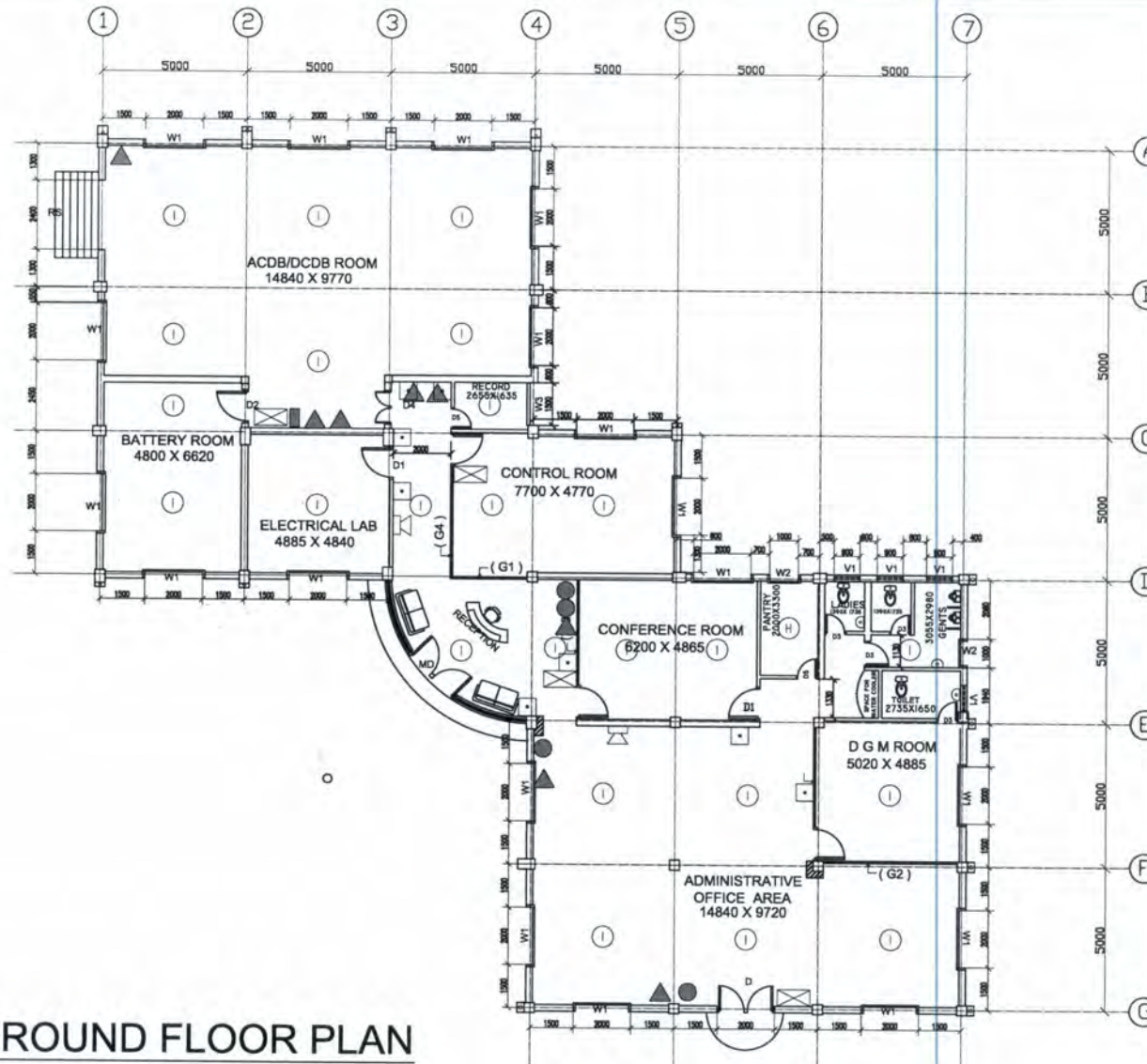

**GROUND FLOOR PLAN**

BILL OF QUANTITY FOR FIRE EXTINGUISHERS.		
SYMBOL	TYPE	QUANTITY
▲	4.5 KG CO2	08+1*
●	9 LITRE WATER	04
■	5 KG DCP	01+4*

\* FOR FIRE WATER PUMP HOUSE AND DG SET.

BILL OF QUANTITY FOR FIRE DETECTORS.		
SYMBOL	ITEM	QUANTITY
⊙	IONIZATION DETECTORS	24
⊙	HEAT DETECTOR	01
□	REMOTE RESPONSE INDICATOR	08
⊗	MANUAL CALL POINT	04
⊠	HOOTER	02+1#

# FOR FIRE WATER PUMP HOUSE.

NOTES :-  
ALL DIMENSIONS ARE IN MM. UNLESS OTHERWISE SPECIFIED.

**POWER GRID CORPORATION  
OF INDIA LIMITED**  
(A Government of India Enterprise)



PROJECT : 800/400/220 KV SUB-STATION

TITLE : STANDARD CONTROL ROOM BUILDING  
LOCATION OF DETECTORS AND PORTABLE  
EXTINGUISHERS

REV.	DESCRIPTION	CIVIL	REVD.	REVD.	MECH.	ELEC.	REVS.	APPD.	DATE.	DRAWING NO.	SCALE	REV.
										C-ENG/CRB-400/FP-STD-02	1:100	0

CLEARED BY



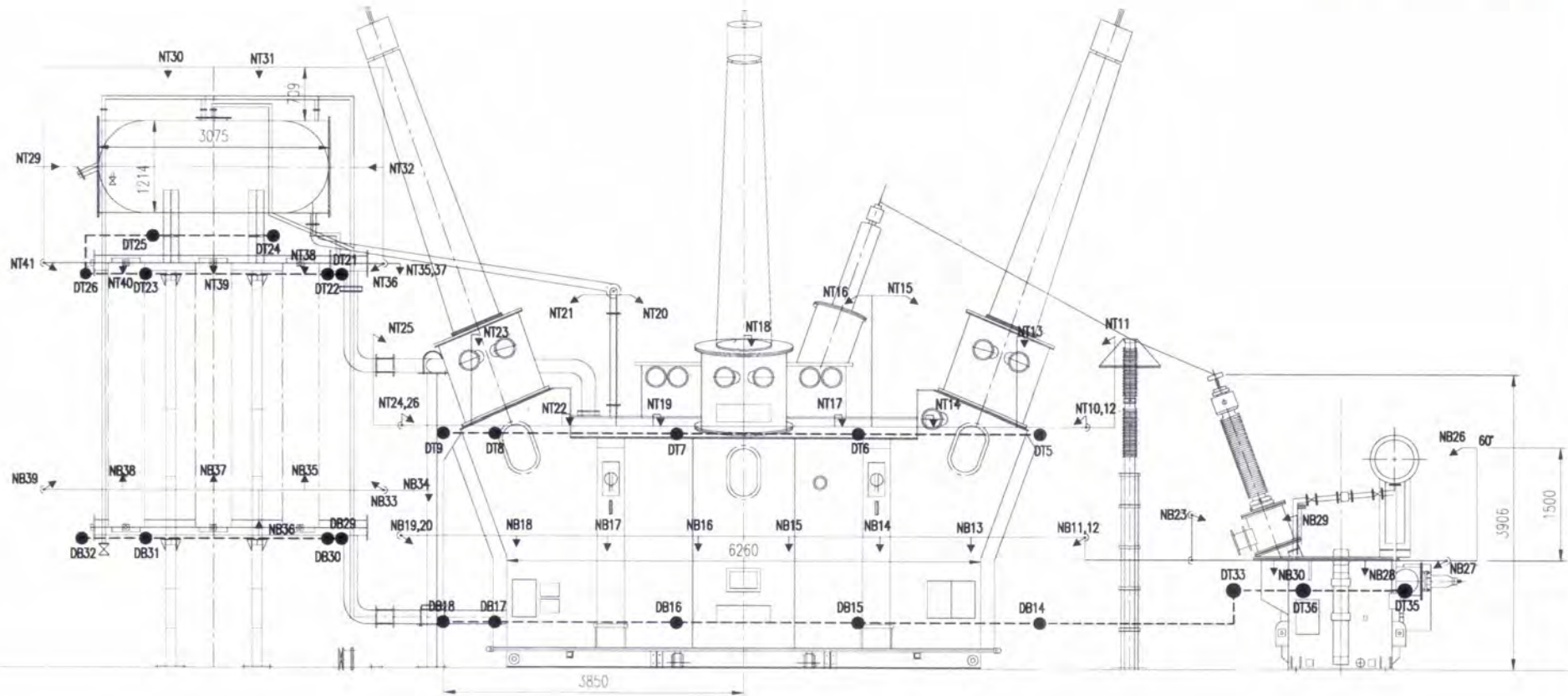

ELEVATION  
TYPICAL SPRAY SYSTEM DRAWING FOR REACTOR

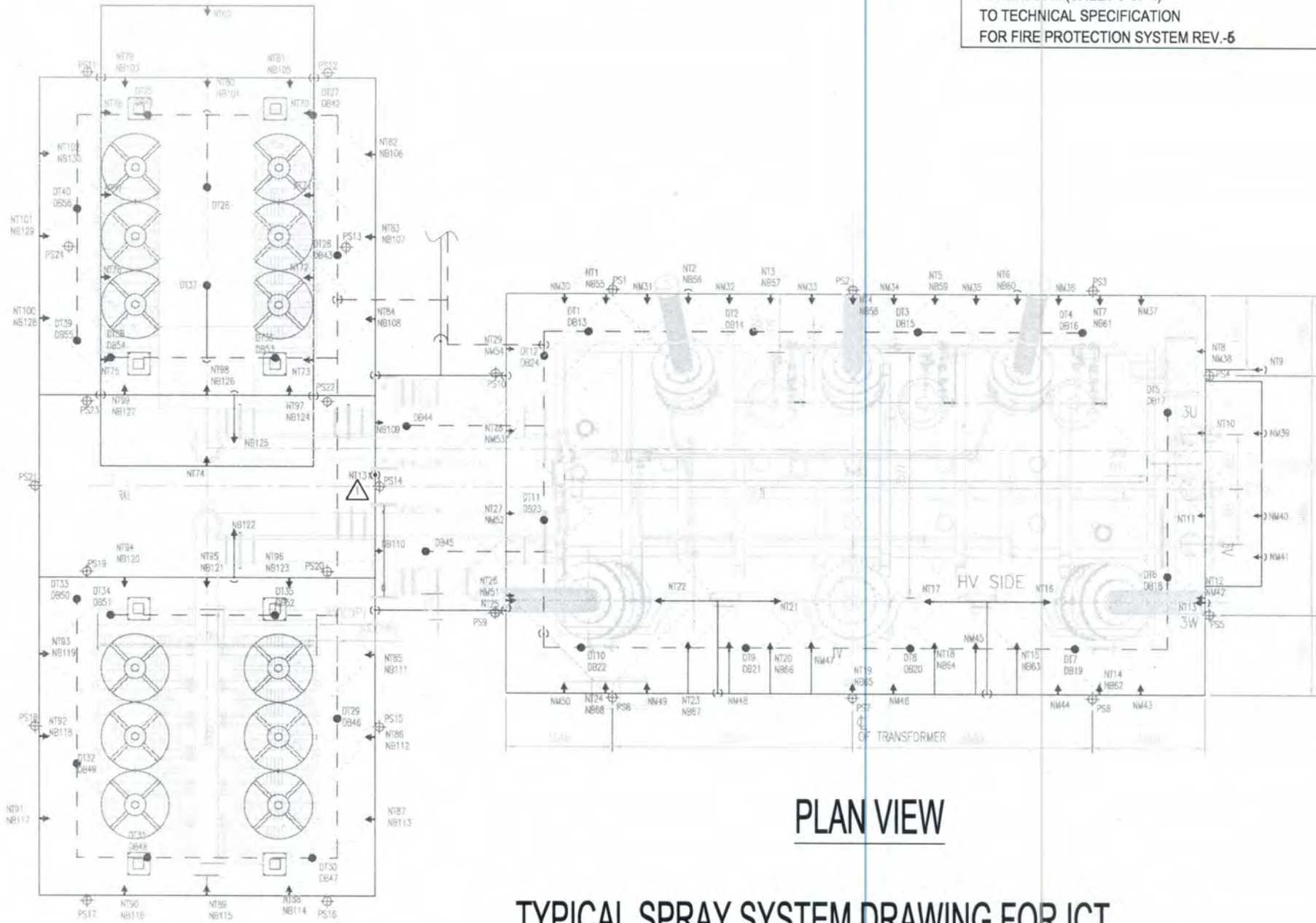

**PLAN VIEW**

**TYPICAL SPRAY SYSTEM DRAWING FOR ICT**

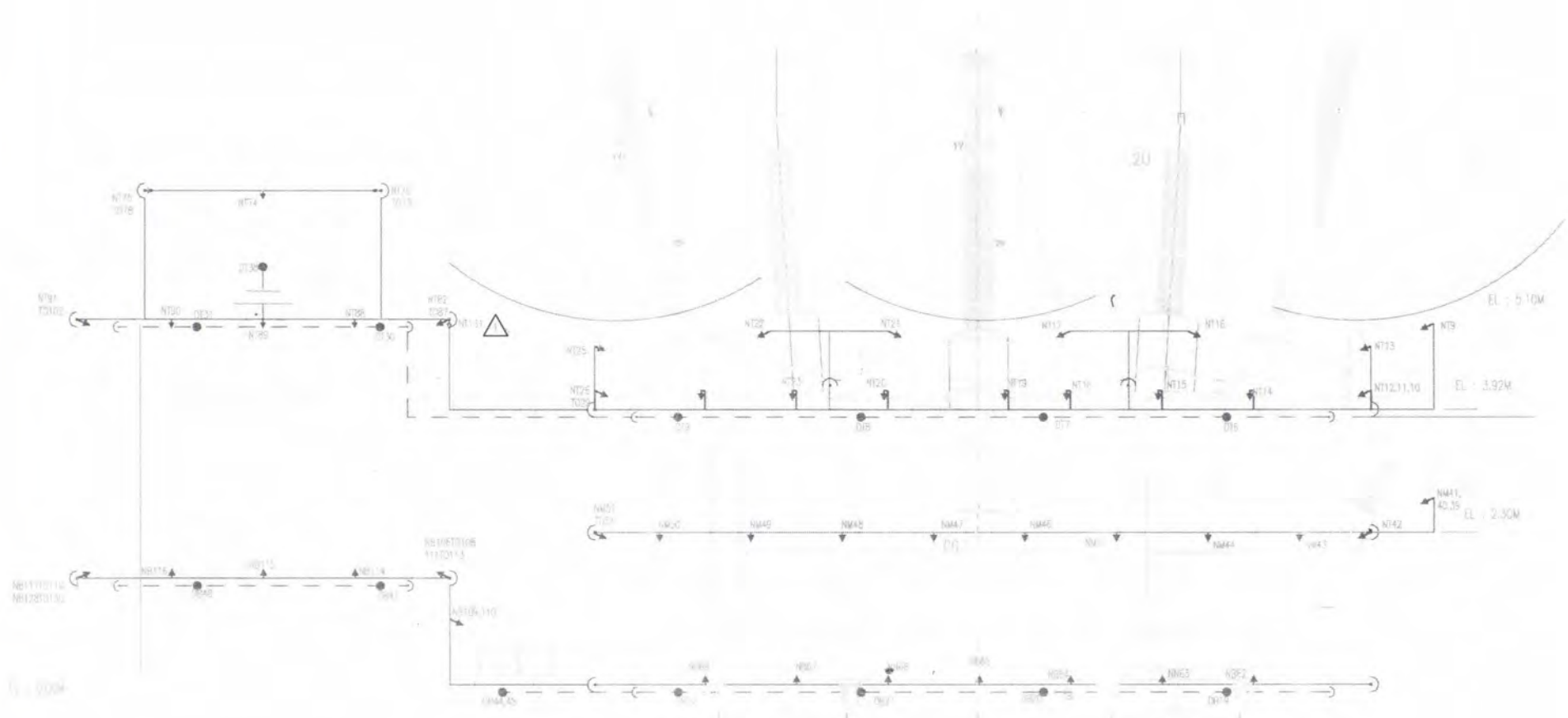

ELEVATION  
TYPICAL SPRAY SYSTEM DRAWING FOR ICT

## TECHNICAL DATA SHEETS

<b><u>DATA SHEET FOR DELUGE VALVE</u></b>		
1.0	Manufacturer	POWERGRID Approved make
2.0	Number & size	As per approved system drawings.
3.0	Type	Differential Diaphragm type.
4.0	Rating	
4.1	Flow in M <sup>3</sup> /hr. 1. 150 mm ø 2. 100 mm ø	170 to 650 50 to 225
4.2	Pressure	Working Pressure – 12.3 kg/cm <sup>2</sup> Test Pressure - 25 kg/cm <sup>2</sup> .
4.3	Pressure drop in equivalent length 1. 150 mm ø 2. 100 mm ø	19M 11M
5.0	<b>Material of construction</b>	
5.1	Body	CI IS:210 Gr. FG 260
5.2	Valve internal	Cast Bronze – IS:318-LTB 2
5.3	Seat Seal	Neoprene Rubber
5.4	Diaphragm	Neoprene Rubber
6.0	Differential pressure required for operation	Differential Ratio – 50%
7.0	Water Motor Gong provided	Yes
7.1	Type	Hydraulic type
7.2	<b>Material of Construction:</b>	
7.2.1	Housing	Al. Alloy-IS:617
7.2.2	Cover/Rotor./Gong	Aluminium to IS:737
7.2.3	Manual actuation lever provided?	Yes
8.0	Remote actuation with Solenoid Valve provided?	Yes
9.0	Resetting type	Manual resetting type
10.0	Deluge valve complete with test and drain valves, manual operation arrangement, supporting structures and all necessary accessories.	Yes
11.0	Approval of Deluge Valve.	FM of USA, UL of USA, LPCB of U.K. or VDS of Germany

**DATASHEET FOR HVW SPRAY NOZZLE**

1.0	Make	POWERGRID Approved make
2.0	Type	High velocity water spray type
3.0	Working pressure	3.5 bar to 5 bar
4.0	Material	Brass
5.0	K factor	As per approved design & drawings
6.0	Quantity	As per approved design & drawings
7.0	Integral non-ferrous strainer provide	Yes
8.0	Approval of HVW spray Nozzle.	FM of USA, UL of USA, LPCB of U.K. or VDS of Germany

**DATA SHEET FOR QUARTZOID BULB DETECTORS**

1.0	Make	POWERGRID Approved make
2.0	Type	Quartzoid bulb type
3.0	Rated pressure	12.3 kg/ cm <sup>2</sup> (175 PSI).
4.0	Hydrotest pressure	30kg/cm <sup>2</sup>
5.0	Material of construction	
5.1	Frame	Bronze
5.2	Bulb	Glass
5.3	Deflector	Copper
6.0	Temperature rating	79°C
7.0	Quantity	As per approved drawings
8.0	Approval of Detector	FM of USA, UL of USA, LPCB of U.K. or VDS of Germany

**DATA SHEET FOR OPTICAL SMOKE DETECTOR**

1.0	Manufacturer	POWERGRID Approved make
2.0	Principle of operation	Light scattering by smoke particles.
3.0	Max. recommended spacing	9 m.
4.0	Normal operating temperature	-10°C to 60°C
5.0	Guaranteed to function properly without any maintenance work for a period of not less than ten (10) years	Yes. Accumulated dust to be removed periodically by blowing air.
6.0	Approval of detector	FM of USA, UL of USA, LPCB of U.K. or VDS of Germany
7.0	Cabling.	2C x 1.5 sq.mm. Un-armoured PVC insulated FR cables conforming to IS 1554 (Part 1).

**DATA SHEET FOR HEAT DETECTOR**

1.0	Manufacturer	POWERGRID Approved make
2.0	Principle of operation	Rate of rise-cum-fixed temperature type.
3.0	Set point of operation	5°C per minute / 55°C
4.0	Max. recommended spacing	6 m.
5.0	Normal operating temperature	-20°C to 70°C
6.0	Guaranteed to function properly without any maintenance work for a period of not less than ten (10) years	Yes. Accumulated dust to be removed periodically by blowing air.
7.0	Approval of detector	FM of USA, UL of USA, LPCB of U.K. or VDS of Germany
8.0	Cabling.	2C x 1.5 sq.mm. Un-armoured PVC insulated FR cables conforming to IS 1554 (Part 1).