

**2 X 500MW NEYVELI NEW TPP (NNTPP)  
(TG-PKG)**

**TECHNICAL SPECIFICATION  
FOR  
CONTROL VALVES WITH ACCESSORIES  
(Pneumatically Operated)**

**VOLUME II-B & III**

SPECIFICATION No: PE-TS-402-145-I 104



**BHARAT HEAVY ELECTRICALS LIMITED  
POWER SECTOR  
PROJECT ENGINEERING MANAGEMENT DIVISION  
NOIDA, INDIA**

1.0 The tender document contains three (3) volumes. The bidder shall meet the requirements of all the three volumes.

1.1 **Volume-I (CONDITIONS OF CONTRACT)**

This consists of four parts as below :-

- Volume-IA : This part contains instructions to bidders for making bids to BHEL.
- Volume-IB : This part contains general commercial conditions of the tender & includes provision that vendor is responsible for the quality of item supplied by their sub-vendors.
- Volume-IC : This part contains special conditions of contract.
- Volume-ID : This part contains commercial conditions for erection & commissioning site work, as applicable.

1.2 **Volume-II TECHNICAL SPECIFICATIONS**

Technical requirements are stipulated in Volume-II which comprises of :-

- Volume-IIA : General Technical Conditions
- Volume-IIB : Technical Specification including Drawings, if any.

1.2.1 **Volume-IIB**

This volume is sub-divided into following sections :-

- Section-A : This section outlines the scope of enquiry.
- Section-B : This section provides "Project Information".
- Section-C : This section indicates technical requirements specific to the contract, not covered in Section-D.
- Section-D : This section comprises of technical specifications of equipments complete with data sheet A, B and C.

**Data Sheet - A** specifies data and other requirements pertaining to the Equipment.

**Data Sheet - B** Specifies data to be filled by the bidder (Data Sheet-B is contained in Volume-III).

**Data Sheet - C** Indicates data/documents to be furnished after the award of contract as per agreed schedule by the vendor (as applicable).

1.2.2 **Volume-III TECHNICAL SCHEDULES**

This volume contains technical schedules and Data Sheets-B, which are to be duly filled by the bidder and the same shall be furnished with the technical bid as per instructions given in Document No. PE-SS-999-100-Q-002 in Volume-III.

2.0 The requirements mentioned in Section-C / Data Sheets-A of section-D shall prevail and govern in case of conflict between the same and the corresponding requirements mentioned in the descriptive portion in Section-D.

**PREPARED BY  
VM RAO, DGM (Q)**

**APPROVED BY :  
RAJIVA K SOOD, AGM & MR**

SDM\_files labelled.doc

**2X 500 MW NEYVELI NEW TPP (NNTPP)  
TG PACKAGE**

**TECHNICAL SPECIFICATION  
FOR  
CONTROL VALVES WITH ACCESSORIES  
(Pneumatically Operated)**

**VOLUME II-B & III**

SPECIFICATION No: PE-TS-402-145-I 104



**BHARAT HEAVY ELECTRICALS LIMITED  
POWER SECTOR  
PROJECT ENGINEERING MANAGEMENT DIVISION  
NOIDA, INDIA**

<b>PREPARED BY:</b>  <b>RAHUL VARSHNEY</b> Sr. Engr. (C & I)	<b>CHECKED BY:</b>  <b>CHETAN MALIK</b> Dy. Mgr. (C & I)	<b>APPROVED BY:</b>  <b>SURESH CHAND SHARMA</b> Sr. Mgr. (C & I)
---	---	---

	<b>Technical specification for Control Valves with Accessories</b> (Pneumatically Operated)  <b>2 X 500MW NEYVELI NEW TPP (NNTPP)</b> (TG-PKG)	SPECIFICATION NO. <b>PE-TS-402-145-I104</b>	
		VOLUME <b>II-B</b>	
		SECTION	
		REV. NO. 00	DATE: 18.12.2014
		SHEET 4	OF 128

## CONTENTS

### VOL-II B

SECTION	DESCRIPTION	PAGE NO.
<b>A</b>	<b>Scope of Enquiry</b>	5
<b>B</b>	<b>Project Information</b>	7
<b>C</b>	<b>Specific Technical Requirements</b>	21
	<b>Hook up Diagram</b>	36
<b>D</b>	<b>Specification for Control Valves</b>	
	- Equipment Specification (PES – 145 – 06)	38
	- Data sheets A & B for Control Valves (Data sheet no. PES-145-06-DS1-0)	55
	- Data sheets A & B for Accessories (Modulating & ON/OFF Duty) (Data sheet no. PES-145-06-DS1-0)	107
	- Data sheets C for Control Valves (Data sheet no. PES-145-06-DS2-0)	110
	- Quality Plan for Control Valves. (No. PE-QP-402-145-I104)	113
	- Bill of Quantity for Control Valves.	119
	- Spares.	122
	- Sub-Vendor List	124



Technical specification for  
**Control Valves with Accessories**  
(Pneumatically Operated)  
2 X 500MW NEYVELI NEW TPP (NNTPP)  
(TG-PKG)

SPEC NO.: PE-TS-402-145-I 104

VOLUME II B

SECTION A

REV. NO. 00 DATE 18.12.2014

SHEET 5 OF 128

**SECTION – A**  
**SCOPE OF ENQUIRY**

	<p style="text-align: center;">Technical specification for  <b>Control Valves with Accessories</b>  (Pneumatically Operated)  <b>2 X 500MW NEYVELI NEW TPP (NNTPP)</b>  <b>(TG-PKG)</b></p>		SPEC NO.: PE-TS-402-145-I 104			
			VOLUME	II B		
			SECTION	A		
			REV. NO.	00	DATE	: 18.12.2014
			SHEET	6	OF	128

## SCOPE OF ENQUIRY

### 1. SCOPE

- 1.1 This specification covers the Design, Manufacture, Inspection and Testing at manufacturer's works, proper packing for transportation and delivery to site of the **Control Valves with Pneumatic Actuator along with Accessories, Start-up/Commissioning and Mandatory Spares** as mentioned in different sections of this specification for **2X500 MW NEYVELI NEW TPP(NNTPP) - TG PACKAGE**.
- 1.2 The quality plan enclosed forms the minimum requirement but not limited to be adhered to by the bidder. Bidder to sign and stamp the same and submit along with the offer as an acceptance.
- 1.3 Bidder to note that Cv test is required to be conducted on one type per size, Cv value. Bidder to group such valves and indicate the same along with the price bid. Unpriced portion to be submitted to engineering.
- 1.4 Following signed & stamped documents with company seal to be submitted by bidder.
- a) Complete offer including calculation sheets, catalogues etc.
  - b) Quality Plan
  - c) Datasheet A & B, duly filled
  - d) Schedule of prices & unit prices, inspection schedule
  - e) Schedule of submission of drawings/documents, equipment manufacture, inspection & dispatch.

### 2 GENERAL TECHNICAL INSTRUCTIONS

- 2.1 It is not the intent here to specify all the details of design and manufacture. However, the equipment shall conform in all respects to high standard of design, engineering and workmanship and shall be capable of performing the required duties in a manner acceptable to the customer / consultant, who will interpret the meaning of drawing and specification and shall be entitled to reject any component or material which in his judgment is not in full accordance herewith.
- 2.2 The omission of specific reference to any component / accessory necessary for the proper performance of the equipment shall not relieve the supplier of the responsibility of providing such facilities to complete the supply within the quoted prices.
- 2.3 BHEL' s / Customer' s representatives shall be given access to the shop in which the equipments are being manufactured or tested and all test records shall be made available to them.
- 2.4 The Equipment covered under this specification shall not be dispatched unless the same have been finally inspected, accepted and Material Dispatch Clearance Certificate (MDCC) is issued by BHEL / Customer.



Technical specification for  
**Control Valves with Accessories**  
(Pneumatically Operated)  
**2 X 500MW NEYVELI NEW TPP (NNTPP)**  
(TG-PKG)

SPEC NO.: **PE-TS-402-145-I 104**

VOLUME II B

SECTION B

REV. NO. 00

DATE : 18.12.2014

SHEET 7 OF 128

## SECTION – B

## PROJECT INFORMATION



## SALIENT FEATURES OF THE SITE & GENERAL PROJECT INFORMATION

### 1.1 Introduction

The project site at Neyveli has distinct location advantages, being at pit-head distance from the source of lignite supply from Mines, making it convenient for transportation of lignite by belt conveyor. Water source is readily available from the nearby mines lake. Besides, other infrastructure such as access road, railway connection etc, already exist.

### 1.2 Power Plant Site

The power plant site is located at Neyveli, opposite to the now defunct Fertilizer and Briquetting & Carbonization Plant, near TPS-I Expansion and TPS-II.

### 1.3 Project & Site Information

- |                                    |   |  |
|------------------------------------|---|--|
| (i). Owner / Purchaser             | : | Neyveli Lignite Corporation Limited (NLC Ltd), Neyveli, Cuddalore District, Tamil Nadu State, India  |
| (ii). Consultant                   | : | Lahmeyer International (India) Pvt. Ltd (LII), Gurgaon, NCR, India.  |
| (iii). Project Title               | : | 2x500 MW Neyveli New Thermal Power Project (NNTPP)   |
| (iv). Location                     | : | 200 kms south of Chennai and 50 kms south-west of Cuddalore  |
| (v). Latitude                      | : | 11° 34' 00" N to 11° 35' 00" N   |
| (vi). Longitude                    | : | 79° 26' 00" E to 79° 27' 00" E   |
| (vii). Elevation above MSL         | : | (+) 67 m   |
| (viii). Nearest Railway Station    | : | Neyveli,   |
| (ix). Nearest Sea Port             | : | Chennai, at a distance of 200 km   |
| (x). Nearest Airport               | : | Chennai, at a distance of 200 km   |
| (xi). Road Access/Approach to Site | : | Connected by Chennai-Thanjavur NH 45C road and state highway connecting Cuddalore - Virudhachalam via Neyveli. Both NH and state high way roads are well connected to NLC township roads. The approach road is approximately 15 kms from Chennai-Thanjavur NH - 45C road |
| (xii). Site Meteorological Data    |   |  |
| • Max ambient temperature          | : | 42.8° C  |
| • Min Ambient Temperature          | : | 26.9° C  |





- Wet bulb temp : 29° C
- Max. Relative Humidity : 92 % in the month of September
- Min. Relative Humidity : 23 % in the month of May
- Rainfall : About 1265.7 mm annually (average)
- Wind direction : South West to North East direction
- Wind Speed : 97.2 km/hr (maximum recorded)  
4.3 km/hr (average wind speed)
- Seismicity : As per IS: 1893 (part 4) (Zone-II)  
Importance factor: 1.75.

\*\*\*\*\*





Technical specification for  
**Control Valves with Accessories**  
(Pneumatically Operated)  
**2 X 500 MW NEYVELI NEW TPP (NNTPP)**  
(TG-PKG)

SPEC NO.: PE-TS-402-145-I 104

VOLUME II B

SECTION C

REV. NO. 00

DATE 18.12.2014

SHEET 10

OF 128

## SECTION-C

# SPECIAL TECHNICAL REQUIREMENT



Technical specification for  
**Control Valves with Accessories**  
(Pneumatically Operated)  
**2 X 500MW NEYVELI NEW TPP**  
(NNTPP)  
(TG-PKG)

SPEC NO.: PE-TS-402-145-I 104

VOLUME **II-B**

SECTION **C**

REV. NO. 00

DATE: 18.12.2014

SHEET 11

OF 128

### SPECIFIC TECHNICAL REQUIREMENTS

The requirements in this section are specific for this project and shall over-ride the specification under Section-D in case of any contradiction. However In case of any contradiction between this SPECIFIC TECHNICAL REQUIREMENTS and customer SPECIFICIFICATION attached further, the customer SPECIFICATION shall prevail.

- 1) Bidder to note that data sheet-B, Format "Schedule of submission of Drawings/ Documents, Equipment Manufacture, Inspection and Despatch" enclosed in Section-D, to be signed and stamped and submitted with the bid. Quality Plan enclosed in Volume-IIB should be furnished duly signed and stamped. NO DEVIATION IS ACCEPTABLE.
- 2) All the formats in Volume-III should be filled-up and furnished with the bid, complete in all respect. Catalogue, Leaflets related with the models of Control Valves as well as each Accessory must be furnished with the offer. In the absence of those, the bid would be considered incomplete and liable for rejection. Catalogue, Leaflets related with the models of Control Valves as well as each accessory must be furnished with the offer.
- 3) The Hook-up diagram for Control valve is attached in Section-C. The Bidder's scope starts from isolation valve at Inst. Air Supply header. The suitable Connector required for connection of pneumatic tubing to isolation valve at Inst. Air Header is also in bidder's scope. The connection details at inst air valve shall be furnished to the successful bidder after the award of contract.
- 4) Valve Body Sizes shall be quoted to take care of the specification requirements like parameters, and limitations of Fluid outlet velocities, Noise Level etc. **However Port (Trim) Sizes shall be selected to suit CV requirement for achieving percentage valve lift as per Technical specification.**
- 5) Type of bonnet shall be according to the service condition. Extension bonnets shall be provided when the maximum temperature of the flowing fluid is greater than 280 Deg C.
- 6) Valve and actuator shall be designed for full differential pressure (Max. shut-off pressure).
- 7) Tolerances on end to end, center to center, center to face shall be in accordance with ASME B16.10.
- 8) Anti-cavitation trims shall be provided for valves with cavitation services and hardened trims for flashing services.



Technical specification for  
**Control Valves with Accessories**  
(Pneumatically Operated)  
**2 X 500MW NEYVELI NEW TPP**  
(NNTPP)  
(TG-PKG)

SPEC NO.: PE-TS-402-145-I 104

VOLUME II-B

SECTION C

REV. NO. 00

DATE: 18.12.2014

SHEET 12

OF 128

- 9) Valve type like cavitation/flashing/ high DP has been indicated in the data sheet. Bidder to offer the valve accordingly. However if process is cavitating, although not indicated in the valve type, bidder to offer Anti-cavitation trim.
- 10) Valve Body and trim design shall achieve Noise abatement. However if the required noise level is not achievable due to design constraint, external Low Noise Pack (Cartridge/Silencer) may be used in the downstream side of the valve. Low Noise pack shall be in Bidder's scope.
- 11) Control valve accessories shall be fitted on the valve body. Integral pneumatic tubing shall be  $\frac{1}{4}$  "OD SS, and fittings shall be of SS. Applicable accessories shall be terminated at the junction box (mounted on the body).
- 12) Type of flow action ("under the seat" or "over the seat") will be selected by the bidder. However wherever downstream side is subjected to vacuum, flow action shall be "flow to close" (over the seat). Specific mention for the same has not been made in the datasheets.
- 13) Trim material and body material has been specified in the Datasheets-A. Bidder to offer body material & trim material combinations equivalent or better than the material specified in Datasheets-A. Wherever there is deviation from the datasheets, bidder to furnish the documentary proof for confirming superior trim material/ body material selection along with their offer. BHEL/ Customer reserves the right to accept/reject any variation to the specification.
- 14) Trim supplied shall be suitable for quick changing and trim exit velocity shall be limited to avoid cavitation.
- 15) The sizing procedure followed shall be as per latest edition of ANSI/ISA or equivalent standard.
- 16) The End Connections Shall Be Socket Welded For Sizes upto 50NB And Butt Welded For sizes above 50NB.
- 17) Stem material for all Control Valves shall be SS 316 STELLITED.
- 18) Facility to adjust the maximum travel of stem & starting point of travel shall be incorporated.
- 19) Cv test shall be carried out for each type of control valve (of same size, Cv, trim characteristics). Cv test reports shall be verified by BHEL. Bidder to furnish the Cv test charges for each type & size of Control valve in their offer. Bidder to note that type test certificates are not acceptable.
- 20) Calculation of Cv, noise level, valve outlet velocity, trim exit velocity, actuator sizing, Data sheet-C in line with Datasheet-A of specification, dimensional drawings / edge preparation



Technical specification for  
**Control Valves with Accessories**  
(Pneumatically Operated)  
**2 X 500MW NEYVELI NEW TPP**  
(NNTPP)  
(TG-PKG)

SPEC NO.: PE-TS-402-145-I 104

VOLUME II-B

SECTION C

REV. NO. 00

DATE: 18.12.2014

SHEET 13

OF 128

- details, etc. shall be submitted for BHEL/Customer review and approval, to reach BHEL within 15 days after receipt of LOI.
- 21) Bidder to note that, **wherever downstream side of the valve is subjected to the vacuum service, bidder to offer double gland packing, and in that case, flow direction of working fluid shall be considered as to close the valve.** Separate indication for the same has not been made in the data sheets-A.
  - 22) Selection of valves and actuators are bidder's responsibility. Any change in selection of type of valve / sizing / percentage opening, calculations, QP, etc., if desired by BHEL / customer during approval of the documents after award of contract, without major changes in process parameters as per tender specification, shall be carried out by bidder without any commercial implication and time delay.
  - 23) Limit switch, position feedback shall be terminated up to JB by 0.5 mm<sup>2</sup>/PVC/Cu/1.1 KV/FRLS shielded control cables. Solenoid valve shall be terminated by 2.5 mm<sup>2</sup> size cable.
  - 24) SS nameplate for control valve shall include tag no./KKS no./Sl. No./body material /size/press rating/trim material/trim type/action on air failure/diaphragm air pressure at full open and close condition.
  - 25) Open to close and close to open time of pneumatic actuator (modulating type) shall be less than 10 sec. Bidder to include volume booster if required to achieve response time less than 10 sec. For ON/OFF type control valve also, the actuator shall have a response time less than 10 sec.
  - 26) Specification of electrical actuator shall not be considered.
  - 27) Hand wheel shall have open/close direction.
  - 28) Air filter regulator shall be designed for an inlet pressure of 5-8 kg/cm<sup>2</sup>.
  - 29) Limit switch shall be designed for 1, 00,000 operations.
  - 30) Expander/reducer b/w the main pipe and the valve inlet and outlet shall be in BHEL's scope of supply. However, any expander/reducer coming b/w the valve and low noise pack (as applicable) shall be in bidder's scope of supply.
  - 31) JB shall be 36 ways with SS body as per enclosed hook-up diagram.
  - 32) Inspection shall be carried out in line with approved drawing/data sheet/QP & specific technical requirements.



Technical specification for  
**Control Valves with Accessories**  
(Pneumatically Operated)  
**2 X 500MW NEYVELI NEW TPP**  
(NNTPP)  
(TG-PKG)

SPEC NO.: PE-TS-402-145-I 104

VOLUME II-B

SECTION C

REV. NO. 00

DATE: 18.12.2014

SHEET 14

OF 128

33) Third party inspection: Customer shall witness the inspection for control valves at the manufacturer's works/ FCRI, PALAKKAD. Bidder to inform 15 days before the date of inspection.

34) In case during erection/commissioning of the control valve, any spares are required which have not been specified in the start-up/commissioning spares list, the same will have to be supplied by the bidder free of cost.

35) The valve sizing shall be suitable for obtaining maximum flow conditions with valve opening at approximately 80% of total stem travel & minimum flow condition not less than 10% of total stem travel. All the valves shall be capable of handling at least 120% of required maximum flow. The stem travel range from minimum flow condition to maximum flow shall not be less than 50% of the total stem travel

36) **SPARES:** The following spares are required to be offered

**(A) Mandatory Spares:**

The items listed in list of mandatory spares attached at section-D, of this specification, are the essential spares required to be offered by the bidder, and the price for which (Lump sum as well as individual) for each item to be quoted separately under the separate heading. The format for price schedule to be filled-up by the bidder is enclosed in Volume-III. The prices for Mandatory spares indicated by the bidder shall be used for bid evaluation purpose.

Each case/container containing Mandatory spares shall be clearly marked or labelled on the outside with the description of the spares contained in it. When more than one item of spare parts is(are) packed in a single case/carton, a general description of the contents shall be shown outside such case/container, and detailed list enclosed. All Cases, Containers and Packages must be suitably marked and numbered for the purpose of identification.

**(B) Recommended Spares:**

In addition to the Mandatory spares mentioned, the bidder shall also furnish a List of Recommended spares for 3 years of normal operation of Control valves / Accessories. BHEL/Customer reserves the right to buy any or all of the recommended spares.

The prices of these spares will remain valid for a period of minimum 6 months after placement of order.

**(C) Start-up & Commissioning Spares:**

Start-up and Commissioning spares are those spares, which may be required during the start-up and commissioning of the Control Valves. All start-up spares, which are supplied under this contract, shall be strictly interchangeable with the



Technical specification for  
**Control Valves with Accessories**  
(Pneumatically Operated)  
**2 X 500MW NEYVELI NEW TPP**  
(NNTPP)  
(TG-PKG)

SPEC NO.: PE-TS-402-145-I 104

VOLUME II-B

SECTION C

REV. NO. 00

DATE: 18.12.2014

SHEET 15

OF 128

parts for which they are intended for replacements. The format for price schedule to be filled-up by the bidder is enclosed in Volume-III

The Start-up and commissioning spares indicated by the bidder shall be a part of the main control valves supply. However bidder to indicate prices separately. The list of these spares required is enclosed in section-D of this specification.

- 37) Bidder to indicate the service life expectancy period for the spare parts under normal working conditions. The spares shall be treated and packed for long storage, under climatic conditions prevailing at site. Small items shall be packed in sealed transparent plastic bags with desiccators' packs as necessary.
- 38) Specification of Electrical Actuator given in section-D shall not be considered.
- 39) In case of multistage valves, pressure drop across each stage shall ensure that the valve does not cavitate in any of the stages.
- 40) Bidder to use epoxy based corrosion resistant paints for painting the valves. Paint of all accessories must comply with this requirement. Bidder to follow the painting procedure as per the specification of painting attached.
- 41) Bidder to furnish a certificate certifying that design of control valve body, bonnet, fittings shall be as per ASTM Standards & tests on Control Valve body shall be as per ANSI B 16.34.
- 42) Bidder to offer latest version of calibration and diagnostic software which should be compatible with latest operating system as used in DCS/Other system(like HMS) where these valves will be hooked-up. In case of up gradation/change in Operating System of PC at DCS/HMS end, the offered calibration and diagnostic software must be upgraded/made compatible to the operating system free of cost. No commercial implication shall be provided on account of the same.

**43) SMART POSITIONER**

- i) The smart positioner shall accept 4-20 mA signal from the control system as input and provide a compatible signal for driving the pneumatic actuator.
- ii) In addition to the electrical-to-pneumatic signal conversion and positioning functions, it shall also perform detailed diagnostics & make available the actuator/control valve faults via hart interface. The hart signal for the detailed faults shall be superimposed on the 4-20 mA control signal itself. The faults to be covered shall include valve jamming, air supply failure, leakage etc.



Technical specification for  
**Control Valves with Accessories**  
(Pneumatically Operated)  
**2 X 500MW NEYVELI NEW TPP**  
(NNTPP)  
(TG-PKG)

SPEC NO.: PE-TS-402-145-I 104

VOLUME **II-B**

SECTION **C**

REV. NO. 00

DATE: 18.12.2014

SHEET 16

OF 128

- iii) It shall have facility of characterisation of the valve (i.e. equal percentage, quick opening, linear, etc.) in the positioners itself.
- iv) Bidder to include in their offer, if any software is required to be installed on the HMS PC (HMS in BHEL'S scope) to communicate with the smart positioners and to access the diagnostic features of the smart positioners. Bidder to furnish price for such software in their offer.
- v) The positioner shall have the facility of detection of control signal failure and making the valve either stayput/open/close as per process requirement upon this condition.
- vi) The smart positioner shall have the fail-freeze feature.

**44) Documentation:**

**(A) Along with the bids: following documents for respective projects separately**

- a) Signed and stamped compliance certificates in attached format (VOL.-III).
- b) Schedule of prices in attached format (VOL.-III).
- c) Schedule of submission of Drg./Doc, Equip. Manufacture, Inspection and Dispatch.
- d) Inspection schedule
- e) Quality Plan duly signed & stamped.

**(B) After the award of contract:**

The documentation as listed below for the project

9 sets of the following documents + 5 sets of CDs to be enclosed with the bids for Approval:

- a. Assembly (dimensional) drawings.
- b. Valve Edge preparation details.
- c. Data sheet-C completely filled-up..
- d. Hook-up diagram of Control Valve with Actuator & Accessories.
- e. Valve & Actuator assembly dimensional drawings with weights.
- f. Quality Plan duly signed and stamped.



Technical specification for  
**Control Valves with Accessories**  
(Pneumatically Operated)  
**2 X 500MW NEYVELI NEW TPP**  
(NNTPP)  
(TG-PKG)

SPEC NO.: **PE-TS-402-145-I 104**

VOLUME **II-B**

SECTION **C**

REV. NO. 00

DATE: 18.12.2014

SHEET 17

OF 128

- g. All calculations like CV, Noise Level, Valve Outlet Velocity, Actuator sizing etc.
- h. All relevant catalogues for the models of the valves as well as accessories finalized.
- i. Bar chart to indicate the time schedule for procurement, manufacture, testing and dispatch.

**(C) Final documentation:**

Copies of documents / drawings to be furnished by the successful bidder shall be as follows:

- a. Category I & IV approved final drawings/datasheets-16 sets with 6 CD-ROMS.
- b. Valve sizing calculations, noise level calculations and outlet velocity calculations - 16 sets with 6 CD - ROMS
- c. Test certificates - 10 sets with 4 CD-ROMS
- d. "As built" drawings - 10 sets with 4 CD-ROMS
- e. Operation & maintenance manuals for Control Valve, Actuator and all accessories - 18 sets with 4 CD-ROMS

**Note: Packing instructions:-**

- 1) After inspection of control valves assembly. Smart Positioner along with Pressure Gauge shall be disassembled & packed separately.
- 2) Packing of the control valves and Smart Positioner along with Pressure Gauge shall be done in separate wooden boxes/cases in order to avoid damage during transit and also during storage at site in tropical climatic conditions for a period of 18-24 months.
- 3) Packing boxes shall have clear marking "to be stored indoor, away from water & dust".



Technical specification for  
**Control Valves with Accessories**  
(Pneumatically Operated)  
**2 X 500MW NEYVELI NEW TPP**  
**(NNTPP)**  
**(SG-PKG)**

SPEC NO.: **PE-TS-400-145-I 104**

VOLUME II B

SECTION C

REV. NO. 00

DATE 08/08/2014

SHEET **Page 08 of 08**

### Guidelines for Packing

- ✓ After inspection of control valves assembly. Smart Positioner along with Pressure Gauge shall be disassembled & packed separately.
- ✓ Threaded connection of Smart Positioner & Pressure Gauge shall be shipped with the end caps fitted to avoid any damage.
- ✓ Instructions with sketch for mounting the Smart Positioner & Pressure Gauge shall be sent along with the aforesaid accessories.
- ✓ Packing of the control valves and Smart Positioner along with Pressure Gauge shall be done in separate wooden boxes/cases in order to avoid damage during transit and also during storage at site in tropical climatic conditions for a period of 18-24 months.
- ✓ All valves & smart positioner along with pressure gauges shall be packed properly with quality wooden planks with proper wooden frame support. Moreover the valves are internally covered with polythene sheets to protect from the water and moisture entry.
- ✓ Stronger shock absorbing cover material like expanded Polyurethane which can take any direct impact on it shall be used for packing
- ✓ Proper reaper support to be provided in the packing and Valve assembly to be aligned properly to avoid the damage of accessories during transit due to vibration effect.
- ✓ Marking for Fragile & Condensing environment shall be done on the packing box.



### The Following Details are to be marked on the Packing Cases

- ✓ Address of consignee
- ✓ Purchase order no.
- ✓ Description of items or title of packing list
- ✓ Weight
- ✓ Dimension of the Box
- ✓ Marking showing upright position
- ✓ Marking showing sling position
- ✓ Marking showing umbrella  
(i.e. for machines/components to be stored under covered storage)



## 9.21 Control Valves

### A. Introduction

The control valves and accessories equipment furnished by the Contractor shall be designed, constructed and tested in accordance with the latest applicable requirements of code for pressure piping ANSI B



31.1, the ASME Boiler & Pressure Vessel code, Indian Boiler Regulation (IBR) & ISA or acceptable equal standards.

#### **B. Control Valve Design & Sizing**

1. The design of all valve bodies shall meet the specification requirements and shall conform to the requirements of ANSI for dimensions, material thickness and material specification for their respective pressure classes.
2. The valve sizing shall be suitable for obtaining maximum flow conditions with valve opening at approximately 80% of total valve stem travel and minimum flow conditions with valve stem travel not less than 10% of total valve travel. All the valves shall be capable of handling at least 120% of the required maximum flow. Further, the valve stem travel range from minimum flow condition to maximum flow condition shall not be less than 50% of the total valve stem travel. The sizing shall be in accordance with the latest edition of ISA Handbook on control valves. While deciding the size of valves, Contractor shall ensure that valves outlet velocity does not exceed 8 m / sec. for liquid services, 150 m/sec. for steam services and 50% of sonic velocity for flashing services. Contractor shall furnish the sizing calculations clearly indicating the outlet velocity achieved with the valve size selected by him as well as noise calculations, which will be subject to Consultant's / Owner's approval during detailed engineering.
3. Control valves for steam and water applications shall be designed to prevent cavitations, wire drawing, flashing on the downstream side of valve and downstream piping. Thus for cavitations / flashing service, only valve with anti-cavitations trim shall be provided. Detailed calculations to establish whether cavitations will occur or not for any given application shall be furnished.
4. Trim shall be multistage type having sufficient number of discrete pressure drop turns (stages) to ensure elimination of vibration, erosive – action, cavitations. Contractor shall identify the number of pressure drop turns in proposed equipment and shall also provide calculation demonstrating compliance to the trim exit velocity.
5. To prevent flow induced vibration and to protect the valve internals from foreign particles such as weld slag flow, direction shall be a flow to close (over the plug) configuration for liquid applications. To maximize noise attenuating benefits and to allow for constant fluid expansion, flow direction will be under the plug for steam and gas applications.
6. Control valves for applications for critical areas shall have permissible leakage rate as per leakage class V. All other control valves such as low and high range feed control valves etc shall have leakage rate as per leakage class IV.
7. The control valve induced noise shall be limited to 85 dBA at 1 meter from the valve surface under actual operating conditions. The noise



abatement shall be achieved by valve body and trim design and not by use of silencers.

8. The characteristic of the control valves shall be determined based on the application / service.
9. On supply air or electrical failure for pneumatic / electrical drive, the valve shall remain full closed, open or stay – put position as per process safety requirement.

#### **C. Valve Construction**

1. Proper selection of valve type and material of construction to meet operating requirement.
2. All valves shall be of globe body design and straightaway pattern with single or double port unless otherwise recommended by the manufacturer to be of angle body type. Rotary valve may alternatively be offered when pressure or pressure drops permit.
3. Valves with high lift cage guided plugs & quick change trims shall be supplied.
4. Cast iron valves are not acceptable.
5. Bonnet joints for all control valves shall be of the flanged and bolted type for easy dis – assembly. Bonnet joints of internal threaded or union type will not be acceptable.
6. Plug shall be of one – piece construction either cast, forged or machined from solid bar stock. Plug shall be screwed and pinned to valve stems or shall be integral with the valve stems.
7. All valves connected to vacuum on downstream side shall be provided with packing suitable for vacuum applications (e.g. double vee type chevron packing).
8. Valve characteristic shall match with the process characteristics.
9. Extension bonnets shall be provided when the maximum temperature of flowing fluid is greater than 280°C.
10. Flanged valves shall be rated at not less than ANSI pressure class of 300 lbs.
11. Teflon shall be used for valve gland packing to suit process requirement.
12. The valve body shall be marked to show direction of flow.

#### **D. Valve Materials**

1. The control valve body material shall be
  - Carbon steel as per ASTM – A216 GR WCB for non – corrosive, non – flashing and non – cavitations services below 275 deg c temperature like Auxiliary Steam flow to Deaerator, CRH flow to Deaerator, Condensate flow to Deaerator etc.



- Alloy steel as per ASTM – A217 GR WC 9 for severe flashing / cavitations services like low load and full load feed water control, HP and LP heaters emergency drains, Deaerator overflow drain to Hotwell etc.
  - Alloy steel as per ASTM A – 217 GR WC 6 for low flashing / cavitations services like HP heaters & LP heaters normal drain control, drain cooler normal level control, gland steam cooler minimum flow etc.
  - 316 SS for condensate service below 300 deg C like condensate normal and emergency make – up controls etc.
2. The control valve trim material shall be
- 17 – 4 PH SS for severe services listed under item D.1, 2nd point & 3<sup>rd</sup> point above
  - 316 SS for services listed at D.1, 4<sup>th</sup> point above and
  - 316 SS with stellite faced guide parts and bushings for remaining applications.
3. However, Contractor may offer valves with body and trim materials better than specified materials and in such cases Contractor shall furnish the comparison of properties including cavitations resistance, hardness, tensile strength, strain energy, corrosion resistance and erosion resistance etc. of the offered material vis – a – vis the specified material for Owner's / Consultant's consideration and approval.

#### **E. End Preparation**

1. Valve body ends shall be either butt welded / socket welded, flanged or screwed as finalized during detailed engineering and as per Owner's / Consultant's approval. The welded ends wherever required shall be butt welded type as per ANSI B 16.25 for control valves of sizes 65 mm and above. For valves sizes 50 mm and below welded ends shall be socket welded as per ANSI B 16.11. Flanged ends wherever required shall be of ANSI pressure – temperature class equal to or greater than that of the control valve body.

#### **F. Valve Actuator**

1. The regulating control valves shall be furnished with pneumatic actuators. The Contractor shall be responsible for proper selection and sizing of valve actuators in accordance with the pressure drop and maximum shut off pressure and leakage class requirements. The valve actuators shall be capable of operating at 60 \*C continuously.
2. Valve actuators and stems shall be adequate to handle the unbalanced forces occurring under the specified flow conditions or the maximum differential pressure specified. An adequate allowance for stem force, at least 0.15 kg / cm<sup>2</sup> per linear millimeter of seating surface, shall be



provided in the selection of the actuator to ensure tight seating unless otherwise specified.

3. The travel time of the pneumatic actuators shall not exceed 10 seconds.
4. For quick opening / closing services (such as fuel oil shut – off valve), the actuator shall be pilot solenoid operated pneumatic drive; the rating of solenoid shall be 24 V DC.
5. Selection of actuator shall be such that it meets the requirements of thrust / torque, stroke length, angular movement, full scale travel time, repeatability & accurate positioning for successful operation of final control element.
6. All the actuators shall have also provision for manual operation during emergency / maintenance along with graduated local position indicator.

#### **G. Control Valve Accessory Devices**

All control valve accessories such as air locks, hand wheels / hand-jacks, limit switches, SMART positioners, diffusers, external volume chambers, reversible pilot for positioners, tubing and air sets, solenoid valves and junction boxes etc. shall be provided as per the requirements.

**Table 9.20  
Specification for E-to-P converter**

<b>S.N</b>	<b>Feature</b>	<b>Minimum Requirement</b>
1	Air Supply	1.5 Kg/Sq. cm
2	Input Signal	4-20 mA DC
3	Output Signal	0.2 to 1.0 Kg/ Sq. cm
4	Linearity	0.5 % of span or better
5	Hysteresis	0.1 % of span or better
6	Ambient Temperature Effect (-20 to +60 °C)	<0.2 % of span per Degree centigrade
7	Mounting	Close to Actuator
8	Protection class	IP-65
9	Enclosure	Die cast Aluminium
10	Drift	+/- 2% of set point per hour

**Table 9.21  
Specification for Smart Positioners**

<b>S.N</b>	<b>Feature</b>	<b>Minimum Requirement</b>
1	Input	4-20 mA DC
2	Power Supply	24 V DC Loop powered
3	Type of Electronics	Microprocessor based with self diagnostic



S.N	Feature	Minimum Requirement
		facility & digital communication by means of HART Protocol
4	Valve position sensing	Non-Contact type with 4-20 mA DC Output
5	Enclosure Type/Material	Weather & Dust proof to IP-65/ Die cast Aluminium
6	Ambient conditions	Suitable for - 30 to +80 *C temperature & 0-95% Humidity
7	Operating Range	Suitable for Full range & Split Range operation
8	Modes of operation	Suitable for Direct & reverse valve action
9	Flow characteristics	Suitable for Linear & Equal percentage Characteristics
10	Fail safe/Freeze feature	Required
11	Air Capacity	Sufficient to handle the Valves Selected/Boosters to be supplied if required.
12	Air supply pressure	To suite the Air Supply Pressure / Quality available
13	Process Connection	1/4" NPT
14	Characteristic Deviation	< =0.5% of span
15	Ambient Temperature effect	< =0.01%/Deg C or better
16	Configuration	Remote Calibration, Auto & Manual Calibration shall be possible
17	Cable Entry	½" NPT, Side or Bottom Entry to avoid water ingress
18	Accessories	a) Display with push buttons for configuration and Display on the positioner itself (Password Protected / Hardware Lock).
		b) For Supply & Output Pressure, Filter Regulator and other accessories shall be provided as on required basis for making system complete
		c) Valves Mounting Assembly For Sliding Stem / Rotary / Single Acting / Double Acting on required basis

1. SMART positioner shall preferably be of the same make as the Control Valve, to ensure repeatability in Calibration, serviceability and proper maintenance of the Control System.
2. SMART positioner shall be a Double stage positioner. The first stage of the positioner shall be typically a flapper-nozzle that serves as a high-gain pre-amplifier. This sensitivity shall be maintained over a wide range of dynamic conditions. Second stage shall be a power amplifier that provides power to drive the actuator. Preferably this shall be a pneumatic relay. Spool Driven type SMART positioners are not preferred due to Higher Dead Band and Poor responsiveness. The SMART positioner shall have pressure sensors to measure the pneumatic outputs to the actuator.



3. The control algorithm for the positioner shall use feedback signal from the motion of the pneumatic relay beam instead of pressure feedback to minimize pneumatic related effects and for stable and smooth response of the control valve. The SMART positioner shall have user adjustable tuning sets to identify the optimum tuning for the total valve assembly. SMART Positioner with HART Communication facility shall communicate all the valve diagnostics to Plant DCS.

**Table 9.22  
Specification for Air Filter Regulator (AFR)**

S.N	Feature	Minimum Requirement
1	Type	Constant Bleed type
2	Inlet Pressure	10 Kg/Sq. cm (maximum)
3	Output	Adjustable from 0-2 Kg/Sq. cm or 0-7 Kg/Sq. cm (Continuous) as required
4	Filter Element	5 microns
5	Filter Element Material	Phosphor Bronze
6	Bowl Material	Metallic
7	Drain	Automatic
8	Enclosure Protection class/ Material	IP-65/ Die cast Aluminium
9	Process connection	¼ " NPT
10	Accessories	All mounting accessories. 2" dial size Pressure gauge.

**Table 9.23  
Specification for Position Transmitter**

S.N	Feature	Minimum Requirement
1	Power Supply	24 V DC Loop powered
2	Type	Non-Contact LVDT type
3	Output	4-20 mA DC/ Linear
4	Accuracy	+/- 1%
5	Enclosure Protection class/ Material	IP-65/ Die cast Aluminium
6	Cable Entry	½" NPT, Side or Bottom Entry to avoid water ingress.
7	Accessories	All mounting accessories

**Table 9.24  
Specification for Limit Switch (Non Contact Type)**

S.N	Feature	Minimum Requirement
1	Type	Non-contact type inductive Proximity/Namur type
2	Sensing distance	10 mm minimum



S.N	Feature	Minimum Requirement
3	Hysteresis	Maximum 10% of sensing distance
4	Indicator	LED indication
5	Protection class	IP 67
6	Integral Cable	1 mtr.
7	Power supply	24 V DC/ 8 V DC
8	Mounting	Flush mounting with check nut
9	Other Feature	Explosion proof enclosures shall be provided wherever required by the application. Shock & Vibration proof.

#### **H. Test & Examination**

1. All valves shall be tested in accordance with the quality assurance programme agreed between the Owner / consultant and the Contractor which shall meet the requirement of IBR and other applicable codes.
2. The tests shall include but not but limited to the following:
  - Non-destructive test as per ANSI B – 16.34.
  - Hydrostatic shell test in accordance with ANSI B16.34 prior to seal leakage test.
  - Valve closure test and seal leakage test in accordance with ANSI B16.34 and as per the leakage class indicated under clause no. B.6.
  - Functional test: The fully assembled valves including actuators control devices and accessories shall be functionally tested to demonstrate times from open to close position.
  - All control valves shall be tested with the positioners for accuracy of positioning and reproducibility over the full range of travel.
  - CV Test : CV test shall be carried out as type test on each size, type and design of the valves as per AISA 75.02 standard and test report shall be furnished for Owner's / consultant's approval.
  - Magnetic particle inspection shall be performed on all machined surfaces of valves having ASA rating of 1500 lbs ASA or greater. All carbon steel valves with 1500 lbs ASA or greater shall receive 100% radio graphic examination in accordance with ASTM – E71.
3. Contractor shall submit test certificates for the tests mentioned in above paragraphs in accordance with ASME and ASTM requirements. In addition Contractor shall also submit for the above equipment, certificate of manufacture and test as required by the Indian Boiler Regulations. The certificate shall be in the prescribed forms III A & III C and shall be endorsed by an Inspection Authority recognized by the Indian Boiler Regulations.



## I. General Requirements

1. Contractor shall furnish all the control valves as finalized during detailed engineering stage without any price repercussions whatsoever depending on the process requirements.
2. Following documents to be furnished by the Contractor after the award of contract.
  - a. Final data sheet for all control valves.
  - b. Detailed dimensional and cross-sectional drawing of control valves, indicating end to end dimensions, various clearances required, weight etc.
  - c. Test certificate for the following :
    - Hydrostatic test for all control valves
    - Magnetic particle inspection for all control valves.
    - Radiographic examination of control valves.
    - Seal tightness test for control valves
    - Materials test certificate for control valves.



### Specifications for Junction Box

S.N	Features	Minimum Requirements
1	No. of Ways	32 (2X16) with 20% spares terminals
2	Material & Thickness	3 mm thick Stainless steel
3	Protection class	IP-65 for outdoor/ IP 55 for Indoor
4	Cable entry	Bottom
5	Mounting	Suitable for Wall/column/structures mounting
6	Terminal Blocks	Rail mounted cage-clamp type suitable for conductor size up to 2.5 mm <sup>2</sup>
7	Grounding	M6 earthing stud shall be provided
8	Gland plate	Removable type
9	Door	Single Lockable door with gasket, able to open sideways, turn able hinge based, latch type lock without handle with common key.
10	Accessories	Tag plate, clamps, fixtures, bolts (SS), nuts (SS), Gasket (Neoprene), cable glands (SS), Lugs (Brass), Fire proof compound for sealing.

- All JB's for outdoor application shall be provided with individual canopies to prevent ingress of water.
- All JB' shall have provision to add 10% additional TB's.
- The marking on terminal strips shall correspond to the terminal numbering on wiring diagrams.
- Separate Terminal blocks shall be used for Analog & Digital Signals & also for signals with different voltage levels.
- The terminal blocks shall be arranged with at least 100 mm clearance between two sets of terminal blocks and between terminal blocks and junction box walls.
- Separate shield bus shall be provided with screw connection for terminating cable shields.
- All spare cable entries shall be provided with plugs.
- All wires in JB shall be neatly dressed & ferruled.
- Double deck type terminal block shall not be used.

**Table 12.4  
Specifications for Cable Glands**



**VOLUME-IIA  
SECTION XVII  
PAINTING SCHEME**





**TABLE OF CONTENTS**

17.1	General .....	343
17.2	Painting For Mechanical & Electrical And Other Equipment, Mechanical Structures, Piping, Ducts Etc.....	343
17.3	Painting Of Steel Structural Works .....	364
17.4	Submission Of Painting Schedule .....	364





## 17.1 General

17.1.1 This specification covers the materials, tools, facilities and quality requirement for surface preparation and painting of steel structures, mechanical & electrical equipments, technological structures, piping, ducts, chutes etc. for 2 X 500 MW Thermal Power Plant as elaborated in the further text.

This specification will be read in conjunction with other parts/ volumes of the Tender specification where other related project requirements have been indicated.

The term "Painting" referred herein covers rust preventive, preventive and decorative coating along with surface preparation of the following areas.

- a) All Mechanical equipment, Technological structures, chutes, piping, ducts etc. unless otherwise specifically indicated in the relevant section
- b) Various types of static and rotary equipment inclusive of electric motors etc.
- c) Steel tanks and vessels
- d) Pipe work including trestles, supports, hangers, etc.
- e) Metallic duct work such as ventilation ducts, gas ducts including supports, hangers, etc.

This is a general guideline to the painting scheme to be followed. However, in case if a specific painting procedure is stipulated in any tendering specification, then this general guideline will be superseded. Any special case which may arise from time to time will be dealt with individually on the merits of each case.

17.1.2 Surfaces made of aluminium, brass, bronze, stainless steel, and other corrosion resistant alloys are not required to be painted unless specified except for identification bands or for aesthetic purposes.

17.1.3 All machined mating surfaces (e.g. flanges) will be properly cleaned, and will be provided with protective coating before despatch.

17.1.4 The complete painting scheme for any item includes the following basic activities:

- i) Proper surface preparation
- ii) Application of primer coats
- iii) Application of intermediate coats and
- iv) Application of finish coats

All the above coats will be of quality paint products and of approved make as stipulated in this specification. The scope of work will also include supply of all paint materials as per specification described herein and of approved quality/ specifications.

## 17.2 Painting For Mechanical & Electrical And Other Equipment, Mechanical Structures, Piping, Ducts Etc.

17.2.1 This section covers the painting requirements for the power plant equipment, structures, piping etc. and any other surface required to be painted.

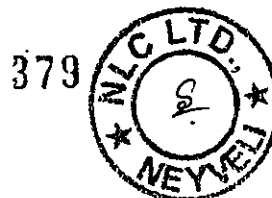



### 17.2.2 Codes and Standards

Painting of equipment will be carried out as per the specifications indicated below and will conform to the relevant IS specification for the material and workmanship.

The following Indian Standards may be referred to for carrying out the painting job :

IS:5	:	Colours for ready mixed paints and enamels
IS:1303:		Glossary of terms relating to paints
IS:2379:		Colour code for identification of pipelines
IS:1477:		Code of practice for painting of ferrous metals in buildings (Parts I & II)
IS:2524:		Code of practice for painting of non-ferrous metals in buildings (Parts I & II)
IS:2395:		Code of practice for painting of concrete, masonry and plaster surfaces (Parts I & II)
IS:2338:		Code of practice for finishing of wood and wood based materials (Parts I & II)
IS:6278 :		Code of practice for white washing and colour washing
IS:3140:		Code of practice for painting asbestos cement building products
IS:158 :		Ready mixed paint, brushing, bituminous, black, lead free, acid, alkali, water and heat resisting
IS : 2074:		Ready mixed paint, air drying, red Oxide Zinc Chrome, priming
IS : 104:		Ready mixed paint, brushing, Zinc Chrome, priming
IS : 2932:		Enamel , synthetic, exterior (a) undercoating (b) finishing specification.

### 17.2.3 Preparation of Surfaces

- Surface preparation being a pre requisite for any paint application, will be such as to clean the surface thoroughly of any materials which will be conducive to premature failure of the paint substrates.
- All surfaces to be painted will be thoroughly cleaned of all grease, oil, loose mill scale, dust, rust and any other foreign matter. Mechanical cleaning by power tool and scrapping with steel wire brushes will be adopted to clear the surfaces. However, in certain locations where power tool cleaning cannot be carried out, sand scrapping may be permitted with steel wire brushes and/or abrasive paper. Cleaning with solvents will be resorted to only in such areas where other methods specified above have not achieved the desired results.

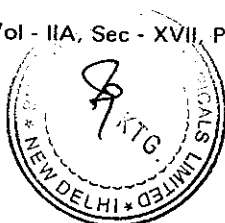



Cleaning with solvents will be adopted only after written approval of the Purchaser/ consultant.

- c) The workmanship will, in general, be in accordance with IS: 1477-1971. Surface of all the steel works to be painted will be thoroughly cleaned and degreased in accordance with IS:1477(Part-I) by means of mechanical and power tool cleaning or shot blasting. The cleaning quality will conform to second quality blast cleaning as per BS-4332 or to SA 2.5 of Swedish Standards Institution SIS 055900. Cleaning of surface will ensure primer coat is rigidly anchored to the virgin metal surface. Primer paint will be applied not later than 2-3 hours after preparation of surface, unless otherwise specified.

**17.2.4** The acceptable surface preparation quality/grade are described under each painting scheme. The procedures covered are solvent cleaning, hand tool cleaning, power tool cleaning and blast cleaning

a) **Solvent cleaning (SP 1) (If applicable)**

The surface will be cleaned by wiping, immersion, spraying or vapour contacting of a suitable solvent or washing with an emulsion or alkaline solution to remove oil, grease, dirt, old paint, etc. Solvent cleaning will not remove rust, scales, mill scales or weld flux. Therefore, before application of paint, solvent cleaning will be followed by other cleaning procedures as stated below.

b) **Hand tool cleaning (SP 2)**

The surface will be cleaned by vigorous wire brushing done manually to St-2 quality. This method effectively removes loosely adherent materials, but would not affect residues of rust or mill scales that are intact and firmly adherent.

c) **Power tool cleaning (SP 3)**

The surface will be cleaned by electric or pneumatic tools to St-3 quality. The tools will be used carefully to prevent excessive roughing of surface and formation of ridges and burns. This method will remove loosely adherent materials but would not affect residues of rust or mill scales that are firmly adherent.

d) **Blast cleaning (SP 4)**

The surface will be cleaned by impingement of abrasive materials, such as graded sand at high velocity created by clean and dry compressed air blast. This method will remove loosely adherent materials as well as adherent scales and mill scales. Prior to application of blast, heavy deposit of oil and grease are removed by solvent cleaning and excessive surface scales are



TG, Vol. IIA, Sec XVII, Painting, NTA2

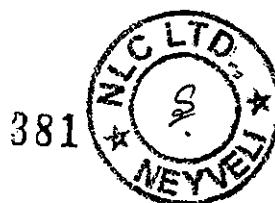



removed by hand tools or power tool cleaning. The surface will be cleaned to Sa-2 1/2 quality which means that to 95% of surface area is free from all rust, mill scales and visible residues, foreign materials, etc. The blast cleaning is not recommended for sheet metal work.

**17.2.5 Primer Paints (P)**

After the surface is prepared in a manner acceptable to purchaser/ consultant, two (2) coats of Primer paints will be applied only on dry and clean surfaces. Second coat of red oxide primer will be applied only after first coat has dried up completely. Coating of primer will in general conform to IS:2074-92 and will be applied by brushing to ensure a continuous film without "holidays".

**a) Primer paint P1: (Epoxy based)**

A two pack air drying epoxy polyamide resin based red oxide –zinc phosphate (primer):

Epoxy content ( % wt)	15 to 18
Air drying time	About 30 minutes ( touch dry) Over night (hard dry)
Dry film thickness ( DFT/coat)	30 microns (min)
Temperature resistance	Upto 120 deg.C dry heat

**b) Primer paint P2 ( Epoxy based)**

A two pack air drying epoxy polyamide with zinc dust of at least 92% zinc dust on the dry film.

Epoxy content ( % wt)	8 to 10
Air drying time	About 10 minutes ( touch dry) 2 hours ( hard dry)
Dry film thickness ( DFT/coat)	40 microns ( min)
Temperature resistance	Upto 300 deg.C dry heat

**c) Primer paint P3 ( Ethyl zinc silicate, EZS, based)**

A two pack heavy duty zinc dust rich silicate primer:

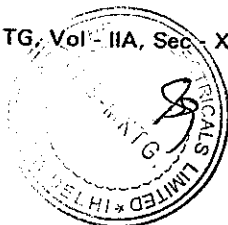



Total solids (% wt)	84 $\pm$ 2
Air drying time	16 hours
Density	3.07 $\pm$ 0.005
Dry film thickness ( DFT/coat)	60 microns ( min)
Temperature resistance	Upto 450 deg.C dry heat

**17.2.6 Intermediate paints (N)**

These paints will be applied over primer coats as an intermediate layer to provide weatherproof seal of primer coats.

**a) Intermediate paint N1**

A two pack air drying high build epoxy resin based paint with MIO.

Air drying time	6 to 8 hours (touch dry) 7 days (full cure)
Dry film thickness ( DFT/coat)	80 microns
Temperature resistance	Upto 180 deg.C dry heat
Compatible with	Primer P1

**17.2.7 Finish Paint (F)**

Finish paint coats will be applied over primer coats and intermediate coats after proper cleaning and touch up of primed coats. Synthetic enamel paint comprising of IS:2932-95 will be used for finish coats.

**a) Finish paint (F1)**

A two pack air drying epoxy polyamide enamel suitably pigmented.

Air drying time	2 to 3 hours (touch dry) 7 days (full cure)
Dry film thickness ( DFT/coat)	30 microns
Temperature resistance	Upto 130 deg.C dry heat





Compatible with	Primers P1 and P2 Intermediate N1
Colour	Generally all shades

**b) Finish paint (F2)**

A single pack synthetic rubber based enamel paint.

Air drying time	2 hours (touch dry) 24 hours (hand dry)
Dry film thickness ( DFT/coat)	25 microns
Temperature resistance	Upto 200 deg.C dry heat
Compatible with	No primers
Colour	Generally all shades

**c) Finish Paint F3**

A single pack heat resistant silicon Aluminum paint.

Air drying time	3 to 4 hours (touch dry) 24 hours (hard dry)
Dry film thickness ( DFT/coat)	25 microns (min)
Temperature resistance	upto 400 deg.C dry heat
Compatible with	Primer paint P3
Colour	smooth aluminium

Heat resistant Silicone Aluminium Paint with suitable air drying time as per IS 13183 Gr I, 25 microns per coat.

- d) After cleaning the dust on the dried up primer/ intermediate paint, first coat of synthetic enamel will be applied. After this first coat dries up hard, the surface is wet scrubbed cutting down to a smooth finish and ensuring that at no place the first coat is completely removed. After allowing the water to get evaporated completely, the second finish coat of synthetic enamel paint



- will be applied only after gently removing the gloss of first coat from entire surface and it is dusted off the surface. The requirement of workmanship will be as per IS:1477-71.
- e) Equipment No. and the name of the equipment will be painted on the surface of the equipment on visible locations in English. Service of the Pipe/Line designation with arrow identification for the direction of flow will be painted on all pipes at visible locations at an interval of 20 metres. Wherever pipelines are insulated, the service of the piping and arrow mark will be painted over the clad surface.
  - f) For painting of structure, equipment, tanks & vessels etc. suggested colour code is given in clause 17.2.8. For items not specified, the colour code to be followed for piping will be in line with IS 9404:2002 (Identification of pipelines used in Thermal Power Plants – Colour Code).
  - g) For insulated pipeline the finish paint will be applied at that place where colour band is to be painted on the aluminium sheeting. The finished paint (colour band) will be of 1m length at that place.
  - h) Colour band for piping will be applied at these following locations-
    - At start and end point.
    - At every 10m intervals.
    - At every T joints and cross connection of piping.
    - At every battery limit of pipeline
    - Near valves before connection with the consumer.
  - i) Width of band

Size of pipe including insulated Pipe line outside diameter	Width of band
80 mm and below	25 mm
Above 80 mm upto 150 mm	50 mm
Above 200 mm upto 300 mm	75mm
Above 350 mm	100 mm



- j) Direction of flow will be indicated by black or white arrow in contrast to the base colour on the pipeline. Length of the arrow will be minimum 125 mm and width will be minimum 65 mm. These will be put at an interval of 10 m.

**17.2.8 Suggested Colour Codes For Painting of Structures, equipments, tanks & vessels etc.**

SL. NO.	ITEM/SERVICE	COLOUR	IS-5	COLUR (BAND	IS-5
1.	Structures, platforms, galleries, ladders and handrails	Dark admiralty grey	632	-	-
2.	Fans, pumps, motors, compressors.	Light grey	631	-	-
3.	Outdoor ,Stand pipes, vent pipes	Aluminium	-	-	-
4.	Indoor Tanks	Aluminium	-	-	-
5.	Vessels & all other proprietary equipment (without insulation & cladding)	Light grey	631	-	-
6.	Tanks (without insulation and cladding)	Aluminium			
7.	Switchgear	Light grey	631	-	-
8.	MCC/ PDB, Control, relay panels, Bus duct	Light grey	631/7078 of IS:1650	-	-



9.	Transformers	Dark admiralty grey	632	-	-
10.	Machinery guards	Signal red	537	-	-
11.	Turbine	Golden Yellow	356		
12.	Generator & exciter	Light grey	631		
13.	Piping (without insulation and cladding)				
14	Feed water	Sea green	217	Light brown	410
15	Condensate	Sea green	217	Light brown	410
16	D M Water	Sea Green	217	Light orange	557
17	Soft water	Sea green	217	French blue	166
18	Bearing cooling water	Sea green	217	French blue	166
19	Potable & filtered water	Sea green	217	French blue	166
20	Service & clarified water	Sea green	217	French blue	166
21	Condenser and Auxiliary Cooling water	Sea green	217	French blue	166
22	Service air	Sky Blue	101	-	-
23	Instrument air	blue	101	White	-
24	Lubricating oil	Light brown	410	Light grey	631
25	Control oil	Light brown	410	Light	557



				orange	
26	Transformer oil	Light brown	410	Light orange	557
27	Hydrogen	Canary yellow	309	Post office red	538
28	Carbon dioxide	Canary yellow	309	Light grey	631
29	Vacuum pipes	Sky blue	101	Black	-
30	Drainage	Black	-	-	-
31	Stand pipes and all Vent pipes	Aluminium	-	-	-

**Notes:**

Where band colour is specified, same will be provided at 10 meter intervals on long uninterrupted lines and also adjacent to valves and junctions.

**17.2.9 Paint Application**

- a) Paint will be applied in accordance with manufacturer's recommendations. The work will generally follow IS 1477 (Part II) for jobs carried out in India and SSPC-PA-I or DIN 55928 or equivalent for jobs carried out outside India. Touch up paint to be applied to cover scratches after erection and assembly of equipment at site.
- b) Paint will not be applied when the ambient temperature is 5 deg. C and below. Also paint will not be applied in rain, wind, fog or at relative humidity of 80% and above.
- c) Each coat of paint will be continuous, free of pores and of even film thickness without thin spots. The first coat of finish paint at site will be applied preferably within three months of the shop paint.
- d) Each coat of paint will be dry sufficiently before application of next coat.
- e) Surface which cannot be painted but require protection will be given a coat of rust inhibitive grease according to IS:958-75 or solvent deposited compound according to IS:1153-75 or IS:1674-60.

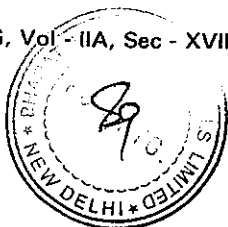



- f) Surface which will be inaccessible after assembly will receive minimum coats of specified primer. Surfaced to be in contact with wood, brick or other masonry will be given one shop coat of the specified primer.
- g) Parts of steel structure to be embedded in concrete will be given a protective coat of Portland cement slurry immediately after fabrication and thoroughly cleaning the surfaces from grease, rust, mill scales etc. No paint will be applied on this part.
- h) The Contractor will furnish paint manufacturer's test report or technical data sheet pertaining to the paint selected. The data sheet will indicate among other things the relevant standards, if any, composition in weight percent of pigments, vehicles, additives, drying time, viscosity, spreading rate, flash points, methods of application quality of surface preparation required, corrosion resistance properties and colour.
- i) Rust preventive coating will be given to HSFG bolt and nut threads.
- j) Machined surfaces / weld edges will be applied with a coating of temporary rust preventive oil.
- k) All threaded and other surfaces of foundation bolts and its materials, insulation pins, anchor channels, sleeves will be coated with temporary rust preventive fluid and during execution of civil works; the dried film of coating will be removed using organic solvents.
- l) The temporary rust preventive coating that already been applied on any components, tubes, pipes etc., will be removed by suitable solvents/ heating to 350-400 Deg.C for an hour before primer paint application-but, in case, it will be ensured that the minimum surface cleanliness required for primer paint application will be Sp2 (equivalent to hand tool cleaning).
- m) All weld edge preparation for site welding will be applied with one coat of weldable primer.
- n) For internal protection of pipes/tubes, VCI pellets will be used at both ends after sponge testing and ends capped. VCI pellets will not be used for SS components and composite assemblies.
- o) Wherever inside surfaces of ducts need protection till erection, two coats of red oxide zinc phosphate primer ( P1) paint to IS 12744 to a DFT of 60 microns will be applied after power tool cleaning.

#### 17.2.10 Painting scheme

- a) For a complete painting scheme of any item being painted, all types of paints are to be procured from the same manufacturer as approved by the purchaser.
- b) The painting scheme to be followed for various mechanical/ electrical equipment / structures is briefly given below for guidance to the Contractor.





**Legend**

SP	Surface preparation quality
P	Primer Paint
2P1 stands for	Two (2) coats of primer paint type P1
N	Intermediate paint
1N 1	One (1) coat of intermediate paint type 1
F	Final Paint
2F1 stands for	Two (2) coats of finish paint type F1
DFT	Dry film thickness
CRT	Clean and retouch
Sa - 2.5	Quality of surface cleaning (i.e. 95 % of the surface area is free from all rust, mill scales and visible residues, foreign materials etc.

**c) Painting Scheme**

Sl no.	Description	Surface Preparation	Painting Scheme		Total DFT in micron
			At shop	At site	
1.	Steel Structure	Sa 2½	2P1 + 1N1	2F1	200
2.	Mechanical equipment (temp. not over 80 deg. C) Both static and rotary equipment	Sa 2½	2P1 + 1 N1	2F1	200
3.	Equipment with hot surfaces (temp. upto 400	Sa 2½	2P2	2F2	130





	deg. C)				
4.	Equipment with hot surfaces (temp. above 400 deg.C)	Sa 2½	2P3	2F3	170
5.	Non insulated pipe/ duct works - Temperature not over 80 °C - Temperature upto 200 °C - Temperature upto 400 °C	Sa 2½	2P1 + 1N1  2P2  2P3	2F1  2F2  2F3	200  50  170
6.	Insulated pipe/duct works	St3	2 coats of Alkyd Red Oxide Zinc Phosphate primer to IS 12744 - DFT 30µ/ coat	Not required	60
7.	Condensate piping, ACW, DMCW, service water, potable water and minor structures etc.	Hand tool/ Power tool cleaning to SSPC-SP2	2 coats of HB Chlorinated rubber based red oxide zinc phosphate primer each 50µ	2 coats of Chlorinated rubber based finish paint each 30µ	160

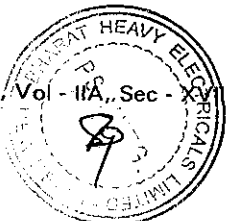



PAINTING SCHEME (METALLIC STRUCTURAL WORKS)				
SURFACES TO BE PAINTED	SURFACE PREPARATION	PAINTING SCHEME		
		PRIMER AT SHOP	INTERM. AT SHOP	FINISHING AT SITE
1) CARPENTRY ANCHOR PLATES AND PIPELINE SUPPORT				
- OUTSIDE	SA 2.5	2P1	1N1	2F1
- INSIDE	SA 2.5	2P1	1N1	2F1
2) BRIDGE CRANE				
- STRUCTURE FOR BEAMS	SA 2.5	P1 + P1(S)	1N1 (S)	2F1
- TROLLEY	SA 2.5	2P1	1N1	2F1
3) HOISTS AND MONORAILS				
- MONORAILS	SA 2.5	2P1	1N1	2F1
- HOISTS	SA 2.5	2P1	1N1	2F1

PAINTING SCHEME (THERMAL CYCLE)				
SURFACES TO BE PAINTED	SURFACE PREPARATION	PAINTING SCHEME		
		PRIMER AT SHOP	INTERM. AT SHOP	FINISHING AT SITE
1) INSULATED PIPE LINE AND VALVES				





PAINTING SCHEME (THERMAL CYCLE)					
SURFACES TO BE PAINTED	SURFACE PREPARATION	PAINTING SCHEME			
		PRIMER AT SHOP	INTERM . AT SHOP	FINISHIN G AT SITE	
STEAM	SA 2.5	2P1/2P 2/2P3	--	--	
FEEDWATER	SA 2.5	2P1/2P 2/2P3	--	--	
DEAERATOR AND FEED TANK					
FEED TANK - INSIDE	SA 2.5	Temporary rust preventive paint			
- OUTSIDE	SA 2.5	2P3 or 2 coats of Heat resistant aluminium paint.			
DEAERATOR - OUTSIDE	SA 2.5	2P2 or 2 coats of Heat resistant aluminium paint.			
3) HEAT EXCHANGER					
- INSIDE	SA 2.5	--	--	--	
- OUTSIDE	SA 2.5	2P1	1N1	--	
4) HEATER					
- INSIDE	SA 2.5	--	--	--	
- OUTSIDE	SA 2.5	Heat resistant Aluminu	--	--	

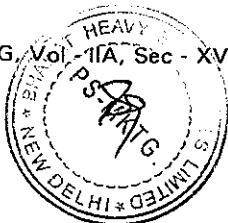



PAINTING SCHEME (THERMAL CYCLE)					
SURFACES TO BE PAINTED	SURFACE PREPARATION	PAINTING SCHEME			
		PRIMER AT SHOP	INTERM AT SHOP	FINISHING AT SITE	
		m paint			
5) PUMPS	SA 2.5	2P1/2P2	1N1	2F1/2F2	
6) VENT					
7) NON INSULATED PIPELINE AND VALVES	SA 2.5	2P1/2P2 / 2P3	--	2F1/2F2/2F3	
8) DRAINS, PIPELINE AND VALVES TRAPS ETC					
- INSULATED	SA 2.5	2P1/2P2 / 2P3	--	--	
- NON INSULATED	SA 2.5	2P1/2P2 / 2P3	--	2F2	
8) TANKS					
- OUTSIDE	SA 2.5	2P1/2P2	--	--	
- INSIDE	--	--	--	--	

PAINTING SCHEME (OIL + GAS-OIL CYCLE)				
SURFACES TO BE PAINTED	SURFACE PREPARATION	PAINTING SCHEME		
		PRIME R AT SHOP	INTERM. AT SHOP	FINIS HING AT SITE

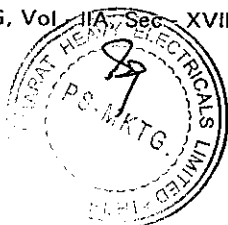



PAINTING SCHEME (OIL + GAS-OIL CYCLE)				
SURFACES TO BE PAINTED	SURFACE PREPARATION	PAINTING SCHEME		
		PRIME R AT SHOP	INTERM. AT SHOP	FINIS HING AT SITE
1) CLEAN / DIRTY OIL TANK				
- INSIDE	SA 2.5	2P4	--	--
- OUTSIDE	SA 2.5	2P1	1N1	2F1
2) PIPE LINE AND VALVES				
- OUTSIDE	SA 2.5	2P1/2P2	1N1	2F1/2F2
- INSIDE	--	--	--	--
3) PUMPS				
- PUMPS	SA 2.5	2P1	1N1	2F1
4) FILTERS				
- OUTSIDE	SA 2.5	2P1/2P1	1N1	2F1/2F2
- INSIDE	--	--	--	--



PAINTING SCHEME (CIRCULATING WATER AND SERVICE WATER)				
SURFACES TO BE PAINTED	SURFACE PREPARATION	PAINTING SCHEME		
		PRIME R AT SHOP	INTERM . AT SHOP	FINISHI NG AT SITE
1) CONDENSER - INSIDE - OUTSIDE	SA 2.5 SA 2.5	-- 2P1	-- 1N1	-- 2F1
- WATER BOX AND TUBE SHEET	SA 2.5	As per specification Volume IIA		
2) PUMPS	SA 2.5	2P1	1N1	2F1
3) PIPELINE AND VALVES - INSIDE - OUTSIDE (OVER GROUND)	SA 2.5 SA 2.5	-- 2P1	-- 1N1	-- 2F1





PAINTING SCHEME (DEMINERALISED WATER)				
SURFACES TO BE PAINTED	SURFACE PREPARATI ON	PAINTING SCHEME		
		PRIME R AT SHOP	INTERM . AT SHOP	FINISHI NG AT SITE
1) PIPELINE AND VALVES - INSIDE - OUTSIDE	-- SA 2.5	-- 2P1	-- 1N1	-- 2F1
2) PUMPS - PUMPS	SA2.5	2P1	1N1	2F1

PAINTING SCHEME (AIR CYCLE)				
SURFACES TO BE PAINTED	SURFACE PREPARATI ON	PAINTING SCHEME		
		PRIME R AT SHOP	INTERM . AT SHOP	FINISHI NG AT SITE
1) PIPE LINE AND VALVES (SA) - OUTSIDE - INSIDE	SA 2.5 --	2P1 --	1N1 --	2F1 --

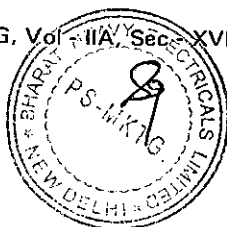



PAINTING SCHEME (AIR CYCLE)				
SURFACES TO BE PAINTED	SURFACE PREPARATI ON	PAINTING SCHEME		
		PRIME R AT SHOP	INTERM . AT SHOP	FINISHI NG AT SITE
2) FILTERS / STRAINERS				
- OUTSIDE	SA 2.5	2P1	1N1	2F1
- INSIDE	--	--	--	--

Note : For Piping, Supports, Hangers, CLH, VLH & Other piping system components/ items Painting Scheme as indicated in following table is also acceptable.





Sl. No.	Description	Surface Preparation & Surface Profile	Primer Coat		Finish Coat			
			Primer Coat	No of coats & DFT	Paint	No of coats & DFT	Shade	Total DFT Micro ns (Min.)
1	Insulated Piping, Components (MS/HRH/CRH/Aux Steam lines,.....)	SSPC-SP3/Power Tool cleaning	Red oxide Zinc Phosphate Primer (Alkyd Base) to IS 12744	2 (30 micro ns per coat)	-----	-----	-----	60
2	Uninsulated Piping, components (Condensate, Boiler Filling, HP/LP dosing, Lube oil, Piping.....)	Hand Tool/Power Tool Cleaning to SSPC-SP2	HB Chlorinated Rubber based Red Oxide Zinc Phosphate Primer	2 (50 micro ns per coat)	Chlorinated Rubber based finish Paint	2 (30 micro ns per coat)	Smoke Grey Shade No 692 of IS 5	160
3	Structures	Hand Tool/Power Tool Cleaning to SSPC-SP2	HB Chlorinated Rubber based Red Oxide Zinc Phosphate	2 (50 micro ns per coat)	Chlorinated Rubber based finish Paint	2 (30 micro ns per coat)	Smoke Grey Shade No 692 of IS 5	160

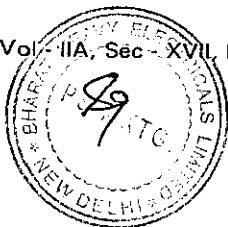



			Primer			)		
4	Hangers & Supports- (CLH,VLH)	Abrasive Blast cleaning to Sa 2 (35-50 microns)	Epoxy Zinc rich primer to IS 14589 Gr.II,% VS=35 Min	1 (40 microns per coat)	Aliphatic Acrylic Polyurethane paint, % VS=40 min	1 (30 microns per coat)	Phirozi Blue Shade No. 176 of IS 5	70
5	Pipe Clams	SSPC-SP3/Power Tool cleaning	Red oxide Zinc Phosphate Primer (Alkyd Base) to IS 12744	1 (30 microns per coat)	Synthetic enamel paint long oil alkyd to IS 2932	1 (20 microns per coat)	Smoke Grey Shade No 692 of IS 5	70
6	Stainless steel/Galvanized items	No Paint	No Paint	No Paint	No Paint	No Paint	No Paint	No Paint

### 17.3 Painting Of Steel Structural Works

17.3.1 All structural steel works covered in the civil scope in Volume V will be painted as specified in Volume V (Design, Fabrication and erection of Structural steel works)

### 17.4 Submission Of Painting Schedule

Contractor will submit a comprehensive painting schedule indicating surface preparation quality, paint applied, total DFT, colour code etc. for Customer/ consultant's approval before the painting of any equipment/ component/ structure etc.



# STANDARD CONTROL VALVE HOOK-UP DIAGRAM (WITH SMART POSITIONER)

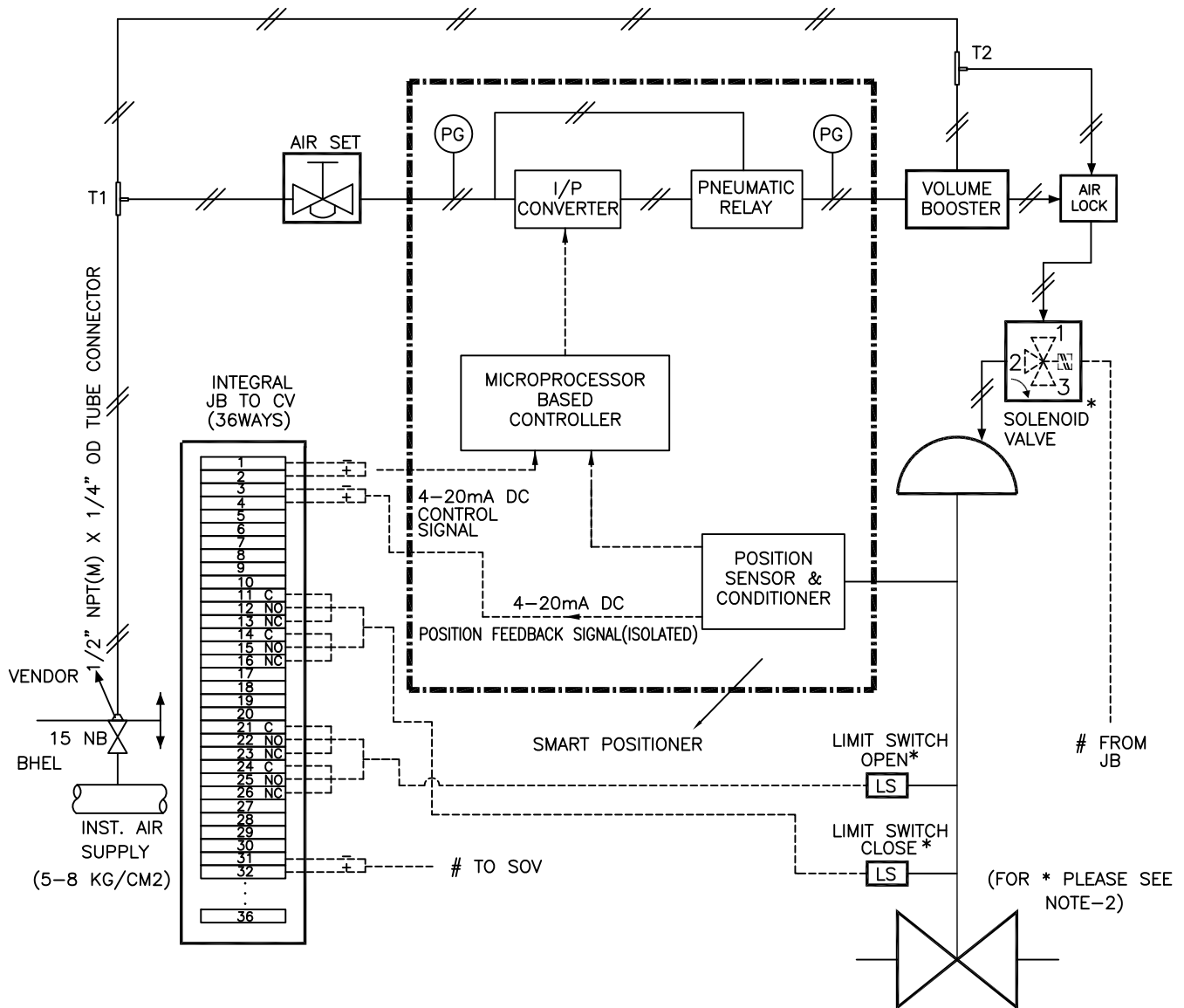

**NOTES :-**

1. POSITION OF EACH VALVE ON SUPPLY AIR FAILURE / ELECTRICAL SIGNAL FAILURE SHALL BE AS PER SPECIFICATION / DATA SHEET.
2. SOLENOID VALVE & LIMIT SWITCHES WILL BE PROVIDED ONLY FOR CONTROL VALVES IF INDICATED IN RESPECTIVE DATA SHEETS.
3. SOLENOID VALVES PORTS CONDITION:  
PORT 1 AND 2 SHALL BE CONNECTED UNDER DE-ENERGISED CONDITION.  
PORT 2 AND 3 SHALL BE CONNECTED UNDER ENERGISED CONDITION.
4. PRESSURE GAUGES REQUIRED FOR AIR SUPPLY & OUTPUT(S).
5. MOUNTING ACCESSORIES AS REQUIRED.
6. POSITION FEEDBACK SIGNAL SHALL BE 2 WIRE 4-20mA ISOLATED SIGNAL.
7. JB TERMINALS SHALL BE CAGE CLAMP TYPE SUITABLE FOR 2.5 SQ. MM COPPER WIRE. EXTERNAL CONNECTION, OF PLUG IN TYPE OR THROUGH CABLE GLAND, SHALL BE AS PER DATA SHEET
8. ALL APPLICABLE ACCESSORIES SHALL BE PROVIDED AS INDICATED IN THE INDIVIDUAL CONTROL VALVE DATA SHEET / ACCESSORIES DATA SHEET.
9. 12 METERS 1/4" PVC COATED COPPER / SS TUBING (AS PER ACCESSORIES DATA SHEET) & 1 SET OF FITTINGS TO BE SUPPLIED FOR EACH CONTROL VALVE FOR CONNECTION TO ISO VLV AT INST AIR HEADER ON ONE END AND TO AIR LOCK RELAY/AIR FILTER REGULATOR ON THE OTHER END. ALL THE BRASS / SS FITTINGS SHALL BE DOUBLE COMPRESSION TYPE.
10. VOLUME BOOSTER (ALONG WITH TEE-T2 AND RELATED TUBING & CONNECTORS) SHALL BE PROVIDED IF REQUIRED. AIR CONNECTION TO VOLUME BOOSTER FROM TEE-T2 SHALL BE PROVIDED.

	STANDARD	DRG. No.	PES-145-06B		
	TITLE:- <b>CONTROL VALVE HOOK-UP DIAGRAM</b>	REV. No.	0	DATE	08.12.14
		SHEET	4	OF	7

## STANDARD CONTROL VALVE HOOK-UP DIAGRAM (FOR ON / OFF TYPE)

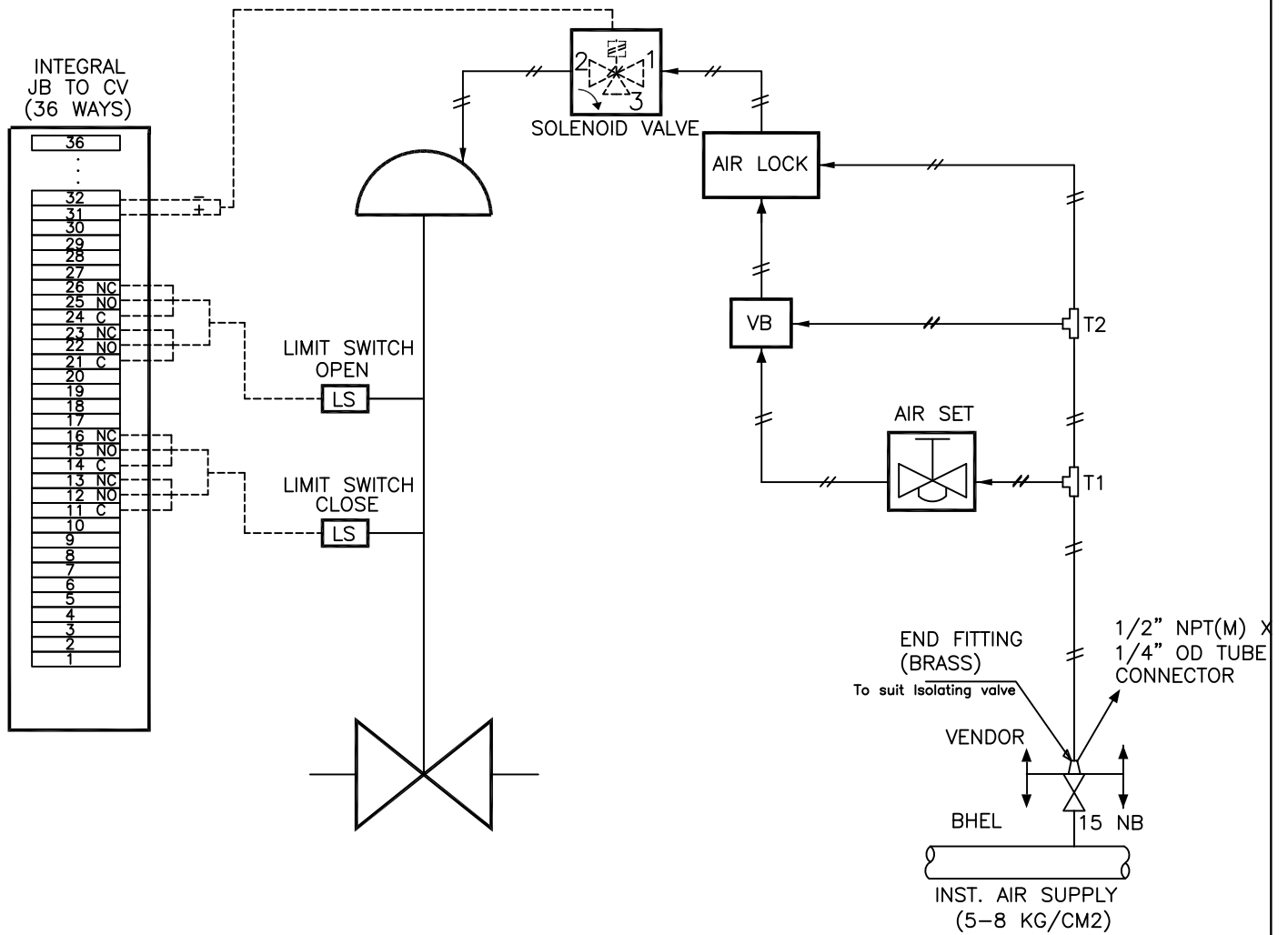

### NOTES :-

1. POSITION OF EACH VALVE ON SUPPLY AIR FAILURE / ELECTRIC SIGNAL FAILURE SHALL BE AS PER SPECIFICATION / DATA SHEET.
2. SOLENOID VALVES PORTS CONDITION:  
PORT 1 AND 2 SHALL BE CONNECTED UNDER DE-ENERGISED CONDITION.  
PORT 2 AND 3 SHALL BE CONNECTED UNDER ENERGISED CONDITION.
3. MOUNTING ACCESSORIES AS REQUIRED.
4. JB TERMINALS SHALL BE CAGE CLAMP TYPE SUITABLE FOR 2.5 SQ. MM COPPER WIRE. EXTERNAL CONNECTION, OF PLUG IN TYPE OR THROUGH CABLE GLAND, SHALL BE AS PER DATA SHEET.
5. ALL APPLICABLE ACCESSORIES SHALL BE PROVIDED AS INDICATED IN THE INDIVIDUAL CONTROL VALVE DATA SHEET / ACCESSORIES DATA SHEET.
6. 12 METERS 1/4" PVC COATED COPPER / SS TUBING (AS PER ACCESSORIES DATA SHEET) & 1 SET OF FITTINGS TO BE SUPPLIED FOR EACH CONTROL VALVE FOR CONNECTION TO ISO VLV AT INST AIR HEADER ON ONE END AND TO AIR LOCK RELAY/AIR FILTER REGULATOR ON THE OTHER END. ALL THE BRASS / SS FITTINGS SHALL BE DOUBLE COMPRESSION TYPE.



**STANDARD**

TITLE:-

**CONTROL VALVE HOOK-UP DIAGRAM**

**DRG.  
No.**

**PES-145-06B**

**REV.  
No.**

**0**

**DATE**

**08.12.14**

**SHEET**

**5**

**OF**

**7**

# STANDARD CONTROL VALVE HOOK-UP DIAGRAM (DOUBLE ACTING PISTON ACTUATOR WITH SMART POSITIONER)

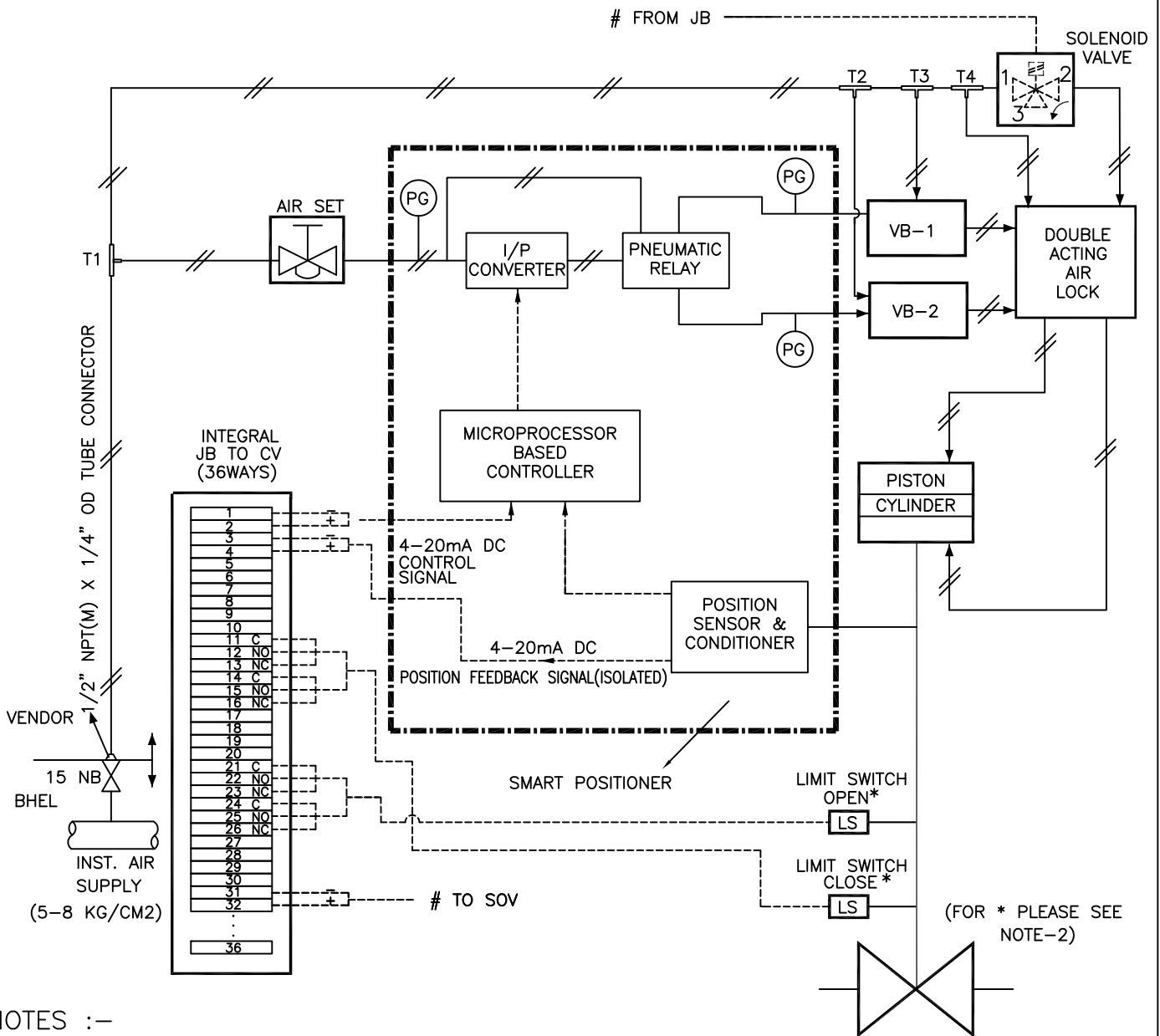

**NOTES :-**

1. POSITION OF EACH VALVE ON SUPPLY AIR FAILURE / ELECTRICAL SIGNAL FAILURE SHALL BE AS PER SPECIFICATION / DATA SHEET. AIR LOCK SHALL BE PROVIDED ACCORDINGLY.
2. SOLENOID VALVE & LIMIT SWITCHES WILL BE PROVIDED ONLY FOR CONTROL VALVES IF INDICATED IN RESPECTIVE DATA SHEETS.
3. SOLENOID VALVES PORTS CONDITION:  
PORT 1 AND 2 SHALL BE CONNECTED UNDER DE-ENERGISED CONDITION.  
PORT 2 AND 3 SHALL BE CONNECTED UNDER ENERGISED CONDITION.
4. PRESSURE GAUGES REQUIRED FOR AIR SUPPLY & OUTPUT(S).
5. MOUNTING ACCESSORIES AS REQUIRED.
6. POSITION FEEDBACK SIGNAL SHALL BE 2 WIRE 4-20mA ISOLATED SIGNAL.
7. JB TERMINALS SHALL BE CAGE CLAMP TYPE SUITABLE FOR 2.5 SQ. MM COPPER WIRE. EXTERNAL CONNECTION, OF PLUG IN TYPE OR THROUGH CABLE GLAND, SHALL BE AS PER DATA SHEET
8. ALL APPLICABLE ACCESSORIES SHALL BE PROVIDED AS INDICATED IN THE INDIVIDUAL CONTROL VALVE DATA SHEET / ACCESSORIES DATA SHEET.
9. 12 METERS 1/4" PVC COATED COPPER / SS TUBING (AS PER ACCESSORIES DATA SHEET) & 1 SET OF FITTINGS TO BE SUPPLIED FOR EACH CONTROL VALVE FOR CONNECTION TO ISO VLV AT INST AIR HEADER ON ONE END AND TO AIR LOCK RELAY/AIR FILTER REGULATOR ON THE OTHER END. ALL THE BRASS / SS FITTINGS SHALL BE DOUBLE COMPRESSION TYPE.
10. VOLUME BOOSTER (ALONG WITH TEE-T2 AND RELATED TUBING & CONNECTORS) SHALL BE PROVIDED IF REQUIRED. AIR CONNECTION TO VOLUME BOOSTER FROM TEE-T2 & TEE-T3 SHALL BE PROVIDED.



**STANDARD**

**DRG. No.**

**PES-145-06B**

TITLE:-

**CONTROL VALVE HOOK-UP DIAGRAM**

**REV. No.**

**0**

**DATE**

**08.12.14**

**SHEET**

**7**

**OF**

**7**

	<p>Technical specification for  <b>Control Valves with Accessories</b>  (Pneumatically Operated)  <b>2 X 500MW NEYVELI NEW TPP (NNTPP)</b>  <b>(TG-PKG)</b></p>	SPECIFICATION NO. <b>PE-TS-402-145-1104</b>	
		VOLUME <b>II-B</b>	
		SECTION <b>D</b>	
		REV. NO. 00	DATE: 18.12.14
		SHEET 31	OF 128

## SECTION – D

- **EQUIPMENT SPECIFICATION**
  - **DATA SHEETS – A & B**
- **DATA SHEETS FOR ACCESSORIES**
  - **DATA SHEETS – C**
  - **QUALITY PLAN**
  - **BILL OF QUANTITY**
    - **SPARES**
  - **SUB-VENDORS LIST**
- **SCHEDULE OF SUBMISSION OF DRAWINGS / DOCUMENTS, EQUIPMENT MANUFACTURE INSPECTION AND DESPATCH**



Technical specification for  
**Control Valves with Accessories**  
(Pneumatically Operated)  
**2 X 500 MW NEYVELI NEW TPP (NNTPP)**  
(TG-PKG)

SPEC NO.: PE-TS-402-145-I 104

VOLUME II B

SECTION D

REV. NO. 00 DATE 18.12.14

SHEET 32 OF 128

**SECTION-D**  
**EQUIPMENT SPECIFICATION**



**SPECIFICATION FOR CONTROL VALVE  
(WITH PNEUMATIC / ACTUATOR)**

SPECIFICATION NO.: PES – 145 – 06

VOLUME II B

SECTION D

REV. NO. 05 DATE : 15/05/2007

SHEET 1 OF 11

**1.0 SCOPE**

This specification covers the Design, Manufacture, Inspection and Testing at the manufacturer's works, proper packing for transportation and delivery to site of Control valve (with Pneumatic/Electric Actuator) for use in Utility/Captive Power Station/Combined Cycle Station.

**2.0 CODES AND STANDARDS**

- 2.1 All the equipments specified herein shall comply with the requirements of the latest issue of the relevant National and International standards.
- 2.2 The Design and Materials used for the components shall also comply with the relevant National and International standards.
- 2.3 As a minimum requirement, the following standards shall be complied with:-

Indian Boiler Regulation (IBR)	
Allowable Seat leakage	: ANSI-B16.104 / FCI-70.2
Pressure & Temperature ratings	: ANSI-B16.34
Enclosure class	: IEC-144 / NEMA / IS-13947
Control Valves	: ISA S-75
Electric Motor operated Actuators	: IS-9334

**3.0 TECHNICAL REQUIREMENTS**

The Control valve, Actuator and the accessories shall be suitable for continuous operation under an ambient temperature of 0-55°C and Relative Humidity of 0-95% unless specified otherwise in volume IIB Section-B or Section-C.

**3.1 Control Valve**

The control valve shall be suitably designed for the operating conditions and system characteristics as specified in the Data Sheet-A.

- 3.1.1 The control valve shall be of globe body design with single port. The valve trim, shall be suitable for quick removal without any cutting or welding.
- 3.1.2 The material of body, internals and packing shall be as specified in the data sheets. Alternatives, considered more suitable for service specified may be given as alternative offer, along with adequate justification. However main offer shall totally meet specification requirements. Asbestos shall not be used for the packing or any other component.
- 3.1.3 The valve bonnet and packing shall be suitable for the service conditions as in Data Sheet-A. Gland sealed type bonnets are not acceptable. Double packing is mandatory for applications involving vacuum service. Bonnets having teflon packing shall have valve stem finished to 2-4 microns. Packing material requiring lubrication will not be acceptable. Justification for proper selection of bonnet & packing shall be furnished in the bid.
- 3.1.4 The valve end connection as specified in Data Sheet-A shall conform to ANSI B16.25 for Butt Weld connection and ANSI B16.5 for flanged ends. End to end dimension shall be as per ANSI 16.10.
- 3.1.5 The valve seat leakage shall be as per ANSI B16.104 / FCI-70.2. The leakage class shall be as per Data Sheet-A.



**SPECIFICATION FOR CONTROL VALVE  
(WITH PNEUMATIC / ACTUATOR)**

SPECIFICATION NO.: PES – 145 – 06

VOLUME II B

SECTION D

REV. NO. 05 DATE : 15/05/2007

SHEET 2 OF 11

- 3.1.6 The valve body shall have the direction of flow embossed on all valves.
- 3.1.7 The sizing shall conform to the requirements of ANSI/ISA(S75- 01), and the valve capacity shall be selected so as to meet the following:
- |  |   |                            |   |                    |
|--|---|----------------------------|---|--------------------|
| Valve with Linear characteristic.        | - | Normal Flow (Design Point) | : | 70-75% valve lift. |
|  | - | Max. Flow                  | : | 90% valve lift.    |
|  | - | Min. Flow                  | : | >10% valve lift.   |
| Valve with Equipercentage Characteristic | - | Normal Flow (Design Point) | : | 75-85% valve lift. |
|  | - | Max. Flow                  | : | 90% valve lift.    |
|  | - | Min. Flow                  | : | >10% valve lift.   |
- ON/OFF Quick open Characteristic - 1.1 times the CV calculated on the basis of maximum flow condition.
- 3.1.8 Calculation for valve sizing, velocity and noise shall be subject to purchaser's approval during contract stage. However responsibility of proper selection and design for the duties specified lies with the vendor. Any modifications required to be done on the valves or actuators & accessories to achieve satisfactory performance of the control system shall be done without any commercial implication.
- 3.1.9 Suitable justification and evidence shall be furnished regarding proper selection of the valve.
- 3.1.10 The valve outlet velocities shall be limited to the following values, unless otherwise specified in the Data sheet-A.
- |     |                |    |  |
|-----|----------------|----|--|
| i)  | Liquid service | <= | 7 Metres/Sec.                          |
| ii) | Steam service  | <= | 1/3 Sonic velocity in the flow medium. |
- 3.1.11 For flashing duty, the trim design shall be such that the vapour bubbles are kept away from valve body.
- 3.1.12 For cavitation service, the trim design shall be of multistage pressure drop type, so as to avoid cavitation altogether, instead of keeping cavitation away from valve parts.
- 3.1.13 In case of predicted noise level above 85 dBA, suitable low noise trim or inbuilt diffusers shall be provided to bring down the noise level below 85dBA.
- 3.1.14 The equivalent weighted sound level measured at 1.5M. above floor level in elevation and one metre horizontally from the control valve expressed in decibels to a reference of 0.0002 microbar shall not exceed 85 dBA (without pipe insulation). The offer shall include noise prediction calculations for each valve.
- 3.1.15 In case of wrong selection/mal operation of valve and for associated actuator during guarantee period, the vendor shall replace the valve suitably with a modified/new valve of design as approved by purchaser and all the expenses for replacement, rectification/modification including transportation both ways will be at vendor's expenses.



**SPECIFICATION FOR CONTROL VALVE  
(WITH PNEUMATIC / ACTUATOR)**

SPECIFICATION NO.: PES – 145 – 06

VOLUME II B

SECTION D

REV. NO. 05 DATE : 15/05/2007

SHEET 3 OF 11

### 3.2 Pneumatic Actuator

The pneumatic actuators shall be employed for modulating or open/close duty, as specified in Data Sheet-A. The bidder shall be responsible for proper selection and sizing of valve actuators in accordance with the pressure drops and shut off pressure.

3.2.1 The pneumatic spring opposed diaphragm actuator for modulating duty shall be capable of positioning the associated valve at desired opening for all the operating conditions specified.

3.2.2 The pneumatic actuator for open/close duty shall be suitable for fast opening/closing of the associated valve.

3.2.3 The actuator design shall allow valve assembly to be mounted at 45° inclination on either side in the vertical plane.

3.2.4 The actuators shall be suitably sized to ensure that the associated valve travel time from full open to full closed position and vice versa is less than 20 seconds under the most stringent service conditions.

3.2.5 The actuator shall be painted with epoxy based paint.

### 3.3 Accessories for Control valve with Pneumatic Actuator

The bidder shall offer all the accessories as specified in the Data Sheet - A for the Pneumatic Actuators under modulating or OPEN/CLOSE duty. The accessories specified shall be supplied duly mounted on the valve actuator and piped with PVC covered copper tube and flare less brass fittings (Refer typical hook up diagram in sheet 12 of 12).

#### 3.3.1 Hand wheel

Hand wheel shall have OPEN & CLOSE direction marking and clockwise rotation as viewed from front shall close the valve. The hand wheel shall have a circular stainless steel plate with Tag number and service.

#### 3.3.2 Local Position Indicator

Each actuator shall be provided with a mechanical pointer attached to stem, moving over a graduated scale with markings, for OPEN, 25%, 50%, 75%, CLOSE positions.

#### 3.3.3 Position Transmitter

The position transmitter shall be supplied as indicated in Data Sheet-A. The electronic position transmitter shall be non-contact type with 4-20 mA DC 2-wire output suitable for 12-50V DC supply. The resistance type position transmitter shall have 0-100 ohm variation for valve position change of 0-100%. The position transmitters of both types shall have accuracy and enclosure class. Necessary cable glands shall be supplied.



**SPECIFICATION FOR CONTROL VALVE  
(WITH PNEUMATIC / ACTUATOR)**

SPECIFICATION NO.: PES – 145 – 06

VOLUME II B

SECTION D

REV. NO. 05 DATE : 15/05/2007

SHEET 4 OF 11

### 3.3.4 Air Filter Regulator

Instrument quality air at suitable pressure of 5.5 Kg/Cm<sup>2</sup>(g) to 7 Kg/Cm<sup>2</sup>(g) shall be supplied to each valve through air filter regulator. The filter regulator shall include an inbuilt blow-down valve, 5 micron size filter. The design pressure for regulator shall be 7 Kg/cm<sup>2</sup>g. The Air filter regulator shall be selected to meet the requirements of positioner/actuator, E/P convertor and air-lock. The flow capacity of the Air filter regulator shall be variable with a knob. Output gauge shall be provided wherever pneumatic positioner is not specified for the valve.

### 3.3.5 Air Lock Relay

Air lock relay shall retain the valve position stayput, in case of air supply failure and shall reset automatically on resumption of air supply. Air lock shall have a threaded plug for evacuating diaphragm air if required for local manual operation.

### 3.3.6 Solenoid Valves

Solenoid valves are meant for interlock & protection purposes overriding the controller signal, and/or to result stayput action on controller signal failure. The Solenoid valve shall be 3-way **Universal** type and the valve internals shall be of stainless steel. The coil shall have class-H insulation and rated for continuous AC/DC duty as specified in Data sheet-A. The enclosure shall be to IP-55. Cable gland shall be provided for cable entry. The solenoid shall in general conform to IS-8935. The solenoid operation shall be universal type. The solenoid shall be suitable for 24V DC supply, unless specified otherwise in Data Sheet-A.

### 3.3.7 Limit Switches

Limit switches are required as specified in the data sheet-A. Each limit switch shall have 2NO+2NC contacts with contact rating of 5A at 240V AC/0.2A at 220V DC unless otherwise specified. The switch enclosure shall conform to IP-55. Each limit switch shall be supplied with cable glands.

### 3.3.8 I/P Converter

I/P Converters shall preferably be of force balance type and shall produce pneumatic output signal corresponding to input current signal, also specified in Data Sheet. Convertor electronics shall be protected against reverse connection of signal polarities and a separate external connection shall be provided to facilitate grounding of instrument casing. Cable glands with neoprene gromets suitable for PVC cables shall be provided. I/P convertor shall have span adjustment facility. I/P convertor enclosure shall conform to IP-55 enclosure class.

### 3.3.9 Positioner

Positioner shall be suitable for accepting controller output signal 0.2-1.0 Kg/cm<sup>2</sup>, 0.2-0.6 Kg/cm<sup>2</sup> or 0.6-1.0 Kg/cm<sup>2</sup> as specified and give an output suitable for the actuator. Pneumatic positioner shall have 3 gauges. All gauges shall have metric scales. The positioner input signal range shall be adjustable. Wherever applicable, it shall be possible to bypass the positioner by means of a switch. **Linearity and Hysteresis shall be as indicated in Data sheet-A**

### 3.3.10 Electro pneumatic Positioner

In place of separate E/P Converter and pneumatic positioner a combined electro pneumatic positioner can also be supplied. The electro pneumatic positioner shall have 2 gauges.

### 3.3.11 Junction Box



**SPECIFICATION FOR CONTROL VALVE  
(WITH PNEUMATIC / ACTUATOR)**

SPECIFICATION NO.: PES – 145 – 06

VOLUME II B

SECTION D

REV. NO. 05 DATE : 15/05/2007

SHEET 5 OF 11

Wherever specified, an integral junction box with all electrical accessories conduited up to JB shall be supplied. The junction box shall have two (2) cable glands for outgoing cables. Junction box shall have enclosure class of IP-55.

### 3.4 Guarantee & Performance

3.4.1 The overall performance of the control valve with pneumatic actuator assembly shall be as follows:-

i)	Hysteresis	:	$\pm$ 1% of span
ii)	Linearity	:	$\pm$ 2% of span
iii)	Sensitivity	:	$\pm$ 0.5% of span.
iv)	Repeatability	:	$\pm$ 1% of span
v)	Accuracy (Overall)	:	$\pm$ 2% of span

3.4.2 The guarantee for the control valve, pneumatic actuator & accessories shall be for 12 months continuous operation from the date of commissioning, unless specified otherwise in VOL-IIB Section-B or Section-C.

### 3.5 Electric Actuator

The electric actuator shall be employed for modulating duty.

3.5.1 The actuator assembly shall be complete with drive motors, gears, hand wheel, signaling & switching units, associated control, integral starter, (when specified) and other accessories as required.

3.5.2 The Electric Actuator shall be capable of positioning the associated valve at the desired opening for all the operating conditions.

3.5.3 The motor shall meet the requirements of Current, torque, Axial thrust, Accelerating & stall time as imposed by the driven equipment.

3.5.4 The motor shall be suitable for direct on line starting.

3.5.5 Motors shall be suitable for inching & plugging duty operations.

3.5.6 The motors shall be capable of starting and accelerating to rated speed at 85% of rated voltage.

3.5.7 The motors shall be rated for continuous operations for modulating duty.

3.5.8 The motor shall operate satisfactorily under the following conditions:

- i)  $\pm$ 10% supply voltage variation at rated frequency.
- ii) -5% to + 3% variation in frequency at rated supply voltage.

iii) Simultaneous variation in voltage and frequency, the sum of absolute percentage not exceeding 10%.

3.5.9 The Actuator shall be suitable for mounting directly on the valve and shall be suitable for mounting in any position. Supports required for inclined mounting shall form part of supply of valve assembly.

3.5.10 The actuator shall be capable of producing the required torque and thrust at the output shaft for satisfactory operation of the associated valve.



**SPECIFICATION FOR CONTROL VALVE  
(WITH PNEUMATIC / ACTUATOR)**

SPECIFICATION NO.: PES – 145 – 06

VOLUME II B

SECTION D

REV. NO. 05 DATE : 15/05/2007

SHEET 6 OF 11

- 3.5.11 Each actuator shall have a hand wheel for emergency operation. The hand wheel shall be designed such that it is declutched automatically when the power supply to the motor is restarted.
- 3.5.12 The hand wheel shall be so arranged that when looking from hand wheel, the valve is closed by rotating the hand wheel in clockwise direction.
- 3.5.13 Motor shall be totally enclosed conforming to IP-65 or better as per data sheet. The enclosure shall be suitable to protect the motor from leakage steam, water or oil from valve joints and glands.
- 3.5.14 Where flameproof enclosures are specified, it shall meet the specification IS-2148.
- 3.5.15 Insulation shall be at least class-B or better and shall be tropicalised to withstand the atmospheric condition.
- 3.5.16 The actuator shall be provided with antifriction bearing in grease filled cartridge.
- 3.5.17 Each actuator shall be provided with a mechanical position indicator to indicate accurately the valve position.
- 3.5.18 The integral starter, if specified in data sheet-A, shall be provided in weatherproof enclosure with protection class not less than IP-65 or better as per data sheet.

The integral starter shall consist of:

- i) Mechanical & Electrically interlocked reversing contractors suitable for class AC4 duty or Thyristor as per data sheet.
- ii) Thermal overload relay.
- iii) Step down control transformer with fuses.
- iv) Interposing relay.
- v) Monitoring relay.
- vi) Open, Close & Stop push buttons.
- vii) Indicating lamps.
- viii) Local-Remote lockable selector switch with spare potential free contacts, wired for remote interface.
- ix) A potential free contact shall be provided for remote annunciation of power failure/overload condition. The contact shall be SPDT, rated for at 5A 240V AC or 0.2A at 220V DC.



**SPECIFICATION FOR CONTROL VALVE  
(WITH PNEUMATIC / ACTUATOR)**

SPECIFICATION NO.: PES – 145 – 06

VOLUME II B

SECTION D

REV. NO.

05

DATE : 15/05/2007

SHEET

7

OF 11

- 3.5.19 The actuator shall be suitably time rated for the duty cycle involved with the necessary number of starts per hour, but in no case, less than 1200 starts per hour.
- 3.5.20 The actuator shall be provided with a suitable control unit for receiving 4-20 mA signal from remote controller.
- 3.5.21 The servomotor gear should have self locking or suitable brake so as to maintain it's last position as and when the motor power is switched off.
- 3.5.22 Thermostat/Thermistor as specified in the data sheet shall be provided for sensing the winding temperature and giving trip command. The trip contact shall be change over type. The contact shall be wired up to the actuator terminal box.
- 3.6 Accessories for Control Valve with Electric Actuator
- 3.6.1 Torque Switches
- i) Each actuator shall be provided with at least one open and one close torque switches each with 2 NO+2 NC contacts. The contacts shall be rated for 5A at 240V AC or 0.2A at 220V DC.
  - ii) The torque switches shall have a minimum accuracy  $\pm 3\%$  of set value.
  - iii) The torque switches shall be provided with calibrated knobs for setting desired torque. Separate knobs shall be provided for close and open torque switches.
  - iv) The torque switches shall be provided with mechanical latching device to prevent operation when unsealing from the positions. The latching device shall unlatch as soon as the valve leaves the end position. If such provision is not possible, the torque switches shall be bypassed by end position limit switches, which open on valve leaving end position. These limit switches are additional to the number of limit switches specified elsewhere.
  - v) The torque switches or worm gear shall be self-locking type so that when torque switch operates it remains operated until the actuator is operated in the reverse.
  - vi) The torque switch enclosure shall conform to IP-55.
- 3.6.2 Limit Switches
- Each limit switch shall have 2NO+2NC contact with contacts rated for 5A 240V AC/0.2A 220V DC unless otherwise specified. The switch enclosure shall conform to IP-55. Each limit switch shall be supplied with cable glands.
- 3.6.3 Space Heater
- A space heater shall be provided in limit switch and starter compartments to prevent condensation. This shall be suitable for the power supply specified in the data sheet. Where integral starters are provided the space heaters shall be wired to control supply within the actuator.



**SPECIFICATION FOR CONTROL VALVE  
(WITH PNEUMATIC / ACTUATOR)**

SPECIFICATION NO.: PES – 145 – 06

VOLUME II B

SECTION D

REV. NO.

05

DATE : 15/05/2007

SHEET

8

OF 11

#### 3.6.4 Remote Position Transmitter

The position transmitter shall be supplied as indicated in Data Sheet-A. The electronic position transmitter shall be non-contact type with 4-20mA DC 2-wire output suitable for 12-50V DC supply. The resistance type position transmitter shall have 0- 100 ohm variation for valve position change of 0-100%. The position transmitters of both types shall have  $\pm 1\%$  accuracy. The enclosure shall conform to IP-55. Necessary cable glands shall be supplied.

#### 3.6.5 Wiring

- i) The actuator and the accessories will be neatly wired up to the terminal boxes.
- ii) The internal wiring shall be minimum of 1 mm<sup>2</sup> stranded PVC insulated copper conductor.
- iii) The wiring shall be identified by means of numbered ferrules on both ends of all wires.

#### 3.7 Terminal and Terminal boxes

##### 3.7.1 Motor Terminal Box

- i) The terminals, terminal boards, terminal boxes, winding tails and associated equipment shall be suitable for connection to supply system having short circuit capacity specified in data sheet and clearance time determined by the associated fuses.
- ii) The terminals shall be stud type insulated from the frame. The insulation shall not be porcelain. The studs shall be of brass or stainless steel or phosphor bronze of adequate size.
- iii) The terminal box shall be totally enclosed conforming to degree of protection IP-65.

##### 3.7.2 Actuator Terminal Box

- i) All terminals of limit and torque switches, space heater, position transmitters, thermostat/thermister shall be brought to a common terminal box. The enclosure shall be to degree of protection IP-65.
- ii) Terminal board with plug in connector shall be provided. Alternatively stud type or insertion type may be considered. Pinch screw type however will not be accepted. All terminals shall be shrouded to prevent accidental contact. Where stud type terminals are offered, it shall be as per clause 3.7.1 (ii).
- iii) There shall be at least five terminals spare to terminate spare cores of cable.

##### 3.7.3 Cable Glands

The motor terminal box and actuator terminal box shall be provided with required number of double compression nickel plated brass cable glands to suit cable type and associated size.

##### 3.7.4 Earthing Terminal

Two earthing terminal shall be provided on either side of motor and actuator terminal box.

##### 3.7.5 Painting

The Actuator shall be painted with epoxy-based paint.



**SPECIFICATION FOR CONTROL VALVE  
(WITH PNEUMATIC / ACTUATOR)**

SPECIFICATION NO.: PES – 145 – 06

VOLUME II B

SECTION D

REV. NO.

05

DATE : 15/05/2007

SHEET

9

OF 11

#### 4.0 TESTING AND INSPECTION

- 4.1 The bidder shall adopt suitable quality assurance plan to ensure that the equipments offered will meet the specification requirements in full.
- 4.2 The bidder shall furnish the Quality Plan in the format enclosed in volume-III. In case the Quality Plan(s) is/are included in volume-IIB, the bidder shall furnish his Quality Plan strictly in line with the same. The Quality Plan shall be discussed and finalised with the technically accepted bidders before opening the price bid. The stages where purchaser would like to be associated for witnessing or verification of tests would be indicated by the purchaser in the Quality Plan before approval.
- 4.3 The following test shall be conducted as a minimum requirement.
- 4.3.1 Control Valve
- Radiographic tests on castings.
  - Dye penetrant tests on machined surface.
  - Ultrasonic tests for the forgings & bars of all valves with 60 Kg/cm<sup>2</sup> & higher ratings.
  - Hydrostatic tests as per ANSI B 16.34 prior to seat leakage tests.
  - Valve closure and seat leakage tests as per ANSI B 16.104 / FCI-70.2.
- 4.3.2 Pneumatic Actuators
- Functional test of actuator and each accessory.
- 4.3.3 Electric Actuator
- Routine tests on motors as per IS: 325.
  - Functional test on actuator and each accessory.
  - Insulation resistance and high voltage test.
  - Stall current & Stall torque test.
  - Output shaft speed and torque of actuator and corresponding current tests.
- 4.3.4 Control valve with Actuator & Accessories fully assembled
- Functional tests of control valve operation along with actuator & accessories.
  - Dimension checks.
- 4.3.5 Type tests or Test Reports
- Valve lift vs. Flow test (**Cv Test**)
  - Degree of protection tests for the enclosures
  - Temperature rise test (**applicable for Electrical Actuator only**).
  - Type test for motor as per IS: 325.
- 4.4 Inspection will be conducted by BHEL and/or their authorised representatives as per the agreed inspection schedule. The inspection schedule will be submitted by the bidder, for BHEL's approval at contract stage. The cost of all tests and inspections will be deemed to have been included in the bid. For all the type tests covered under 4.3.5 above, "Type Test Certificates" as per agreed Quality Plan shall be furnished. In the absence of the same, such Type Tests shall be arranged at the Vendor's works in the presence of BHEL and/or their authorised representatives or in independent Test House/Laboratory approved by BHEL.



**SPECIFICATION FOR CONTROL VALVE  
(WITH PNEUMATIC / ACTUATOR)**

SPECIFICATION NO.: PES – 145 – 06

VOLUME II B

SECTION D

REV. NO.

05

DATE : 15/05/2007

SHEET

10

OF 11

4.5 The Standard QP is included in this specification to enable bidder to understand the extent of inspection and testing requirements to execute this job. The successful bidder has to follow the agreed QP, taking care of customer requirements mentioned in Sec-C and submit QP for final approval by BHEL / Customer.

**5.0 SPARES AND CONSUMABLES**

5.1 Commissioning Spares and consumables

As part of the main equipment supply, the bidder shall supply all commissioning spares and consumables required during Start-up,

5.2 Mandatory Spares

The bidder shall offer along with main offer, the Mandatory Spares as specified in Volume IIB Section-C of the specification. The Mandatory Spares offered shall be of the same make and type as the main equipment.

5.3 Recommended Spares

The bidder shall furnish a list of Recommended Spares along with the normal service expectancy period and frequency of replacement; quantities recommended for 3 years operation along with unit rate against each item to enable BHEL / BHEL's Customer to place a separate order later, if required.

5.4 Special Tools & Tackles

The bidder shall furnish a list of Special Tools & Tackles included in the bid.

**6.0 DRAWINGS AND DOCUMENTS**

6.1 The bidder shall furnish the following documents in required number of copies along with the bid:

6.1.1 Data sheet-B, completely filled-up along with all enclosures.

6.1.2 Wiring diagrams for Electrical Actuators.

6.1.3 Hook up diagrams of Control Valve with Actuator & accessories.

6.1.4 Valve & actuator assembly dimensional drawings with weights.

6.1.5 Quality Plan

6.1.6 All relevant Catalogs with detailed technical information.

6.1.7 Bar-chart to indicate the time schedule for procurement, manufacture, testing and despatch.

6.2 The successful bidder shall furnish the following documents in required number of copies to BHEL during the contract stage:

6.2.1 For approval

i) Dimensional drawings.



**SPECIFICATION FOR CONTROL VALVE  
(WITH PNEUMATIC / ACTUATOR)**

SPECIFICATION NO.: PES – 145 – 06

VOLUME II B

SECTION D

REV. NO. 05 DATE : 15/05/2007

SHEET 11 OF 11

- ii) Installation drawings with overall dimensions of the completed equipment and clearances for operation and maintenance.
- iii) Data sheet-C, completely filled-up along with all the enclosures including the sizing calculations & noise calculations.
- iv) Quality Plan.
- v) Test Certificates.

#### 6.2.2 Final / As-built Drawings

Final / As-built drawings / CDs in required number of copies shall be submitted.

#### 6.3 Operation & Maintenance Manuals

O&M Manuals in required number of copies shall be submitted. O&M manuals shall also contain storage and commissioning instructions.

### 7.0 MARKING AND PACKING

#### 7.1 Marking

A stainless steel metal nameplate should be permanently fixed on each equipment giving its tag number and technical specifications.

#### 7.2 Packing

All equipment / materials shall be suitably packed and protected for the entire period of dispatch, storage and erection against impact, abrasion, corrosion, incidental damage due to vermin, sunlight, high temperature, rain, moisture, humidity, dust, sea water spray (where applicable) as well as rough handling and delays in transit and storage in open.

55

### 8.0 APPLICABLE DATA SHEET FORMS

This document shall be read with one or more of the following data sheet forms :

- Data sheet A&B for Control Valve with Pneumatic Actuator : Data sheet no. PES-145-06-DS1-1
- Data sheet C for Control Valve with Pneumatic Actuator : Data sheet no. PES-145-06-DS2-1
- Data sheet A&B for Control Valve with Electric Actuator : Data sheet no. PES-145-06-DS3-1
- Data sheet C for Control Valve with Electric Actuator : Data sheet no. PES-145-06-DS4-1

	<p>Technical specification for  <b>Control Valves with Accessories</b>  (Pneumatically Operated)</p> <p><b>2 X 500MW NEYVELI NEW TPP (NNTPP)</b>  <b>(TG-PKG)</b></p>	SPECIFICATION NO. <b>PE-TS-402-145-1104</b>	
		VOLUME <b>II-B</b>	
		SECTION <b>D</b>	
		REV. NO. 00	DATE: 18.12.14
		SHEET 44	OF 128

## SECTION – D

# SPECIFICATION FOR MICROPROCESSOR BASED ELECTRONIC POSITIONER (SMART)

(PES – 145 – 06A)

	<b>SPECIFICATIONS FOR MICROPROCESSOR BASED ELECTRONIC POSITIONER (SMART )</b>	SPECIFICATION NO.: PES – 145 – 06A	
		VOLUME	
		SECTION	
		REV. NO. 00	DATE : 19.03.2008
		SHEET 1	OF 4

### 1.0 Electrical

Input Signal	4-20mA
Power Supply	Loop Powered from the output card of Control System (12-30 V DC)
Hart Protocol	Compatibility For Remote Calibration & Diagnostic (Super-Imposed HART Signal On Input Signal (4-20mA)
Valve Position Feedback (4-20mA)	Position Sensing 4-20mA O/P Signal For Control System To Be Provided. If non contact type of Position feedback signal is required, Position transmitter to be separately provided.

### 2.0 Environment

Operating Temperature	(-) 30 To 80 Deg.C
Humidity	0-95%
Protection Class	IP-65 (Minimum)

### 3.0 Software For Configuration & Diagnostic

Software	Windows Based Software, Software Shall Meet The Requirement For Configuration, Diagnostics, Calibration And Testing Of the Actuator. Valve positioning timing, actuator leakage, and Valve Wear & tear, fault alarm to be offered as a minimum. Easily up gradable with same hardware and compatible with any HART management systems / AMS.
Diagnostic/Test Features (Optional)	Advanced Diagnostic Features Like Stroke On Line Partial Closure Test, Valve Signature Analysis (Online graphical representation ), Step Response Test, Valve Friction/Jamming Detection Etc To Be Provided.

	<b>SPECIFICATIONS FOR MICROPROCESSOR BASED ELECTRONIC POSITIONER (SMART )</b>	SPECIFICATION NO.: PES – 145 – 06A	
		VOLUME	
		SECTION	
		REV. NO. 00	DATE : 19.03.2008
		SHEET 2	OF 4

Factory Valve Signature Tests Reports (Pr Vs Valve Travel And Travel Vs I/P Signal) Are To Be Provided.

Hardware                      PC                      For Configuration/Software (OPTIONAL)

Test Certificates                      Test Certificates As Per Manufacture Standard/Relevant Standard Are To Be Submitted.

Configuration / Remote Calibration, Auto & Manual Calibration Shall Be Possible.

#### 4.0        Modes

Valve Action	Direct & Reverse, Valve Action. ( Same positioner for Single Acting or Double Acting And no separate relays required for changing from Single acting to double).
Flow Characterization	Possible to fit valve characteristic curve linear & Equal percentage
Fail Safe/Fail Freeze (Optional)	Fail Safe/Fail Freeze feature is to be provided.

#### 5.0        Performance

Characteristic Deviation	$\leq 0.75\%$ of span
Ambient temp effect	$\leq 0.01\%$ /Deg C or better.
Dead Band	Adjustable 0.1 to 10%.
Scan Time	10ms
Resolution	$\leq 0.05\%$
Sensitivity/Linearity	0.3-0.4% of FS
Repeatability	0.32% of FS
Auto-Tune	Yes

	<b>SPECIFICATIONS FOR MICROPROCESSOR BASED ELECTRONIC POSITIONER (SMART )</b>	SPECIFICATION NO.: PES – 145 – 06A	
		VOLUME	
		SECTION	
		REV. NO. 00	DATE : 19.03.2008
		SHEET 3	OF 4

Leak Test Yes

## 7.0 EMC & CE compliance

Required International Standard Like EN/IEC. To En50081-2&En50082 or equivalent

## 8.0 Accessories

In Built Operator Panel Display With Push Buttons For Configuration And Display On The Positioner Itself

Hand Held Hart Calibrator (Optional) Universal Hart Calibrator To Be Provided, One Per Unit.

Press Gauge Block For Supply & Output Pr., Filter Regulator Other Accessories Shall Be Provided As On Required Basis For Making System Complete.

Electrical cable entry  $\frac{1}{2}$ -Npt, side or bottom entry to avoid water Ingress.

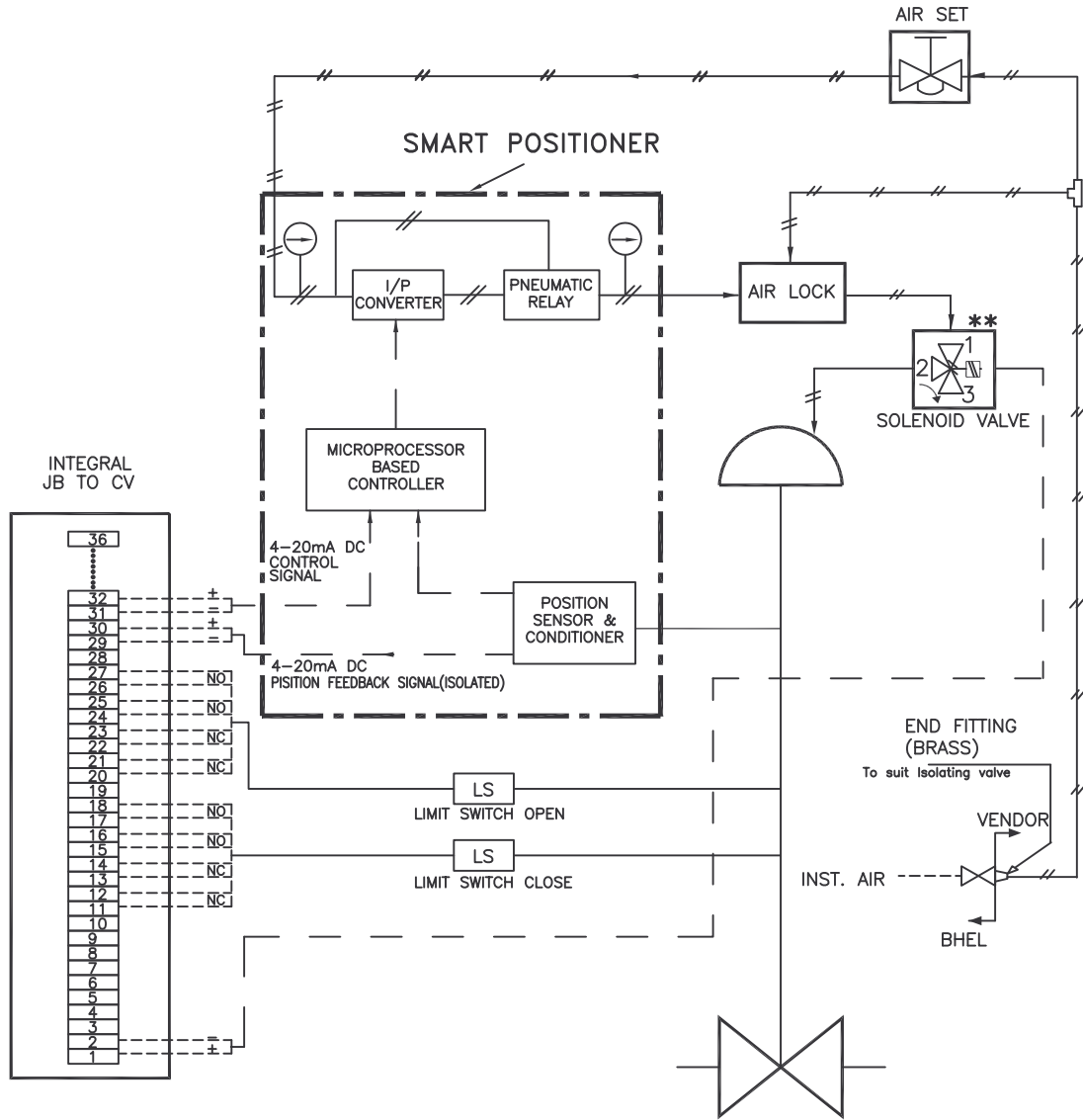

NOTE:—

1. SOLENOID VALVE WILL BE PROVIDED ONLY FOR ON/OFF DUTY VALVES & FOR CONTROL VALVES WHERE OPEN/CLOSE INTERLOCK IS REQUIRED AND INDICATED IN RESPECTIVE DATA SHEETS.
2. SOLENOID VALVES PORT CONDITION:  
PORT 1 & 2 SHALL BE CONNECTED UNDER DE-ENERGISED CONDITION.  
PORT 2 & 3 SHALL BE CONNECTED UNDER ENERGISED CONDITION.
3. FOR ON/OFF DUTY PNEUMATIC CONTROL VALVE, SMART POSITIONER SHALL NOT BE APPLICABLE.
4. JB TERMINALS SHALL BE CAGE CLAMP TYPE SUITABLE FOR 2.5 SQ. MM COPPER WIRE.
5. 10 METERS 1/4 " PVC COATED COPPER TUBING AND 1 SET OF FITTINGS TO BE SUPPLIED FOR EACH CONTROL VALVE FOR CONNECTION TO ISO VALVE AT INST AIR HEADER ON ONE END AND TO AIR LOCK RELAY/AIR FILTER REGULATOR ON THE OTHER END.
6. VOLUME BOOSTER IF REQUIRED SHALL BE PROVIDED.

\*\* APPLICABLE TO VALVES WHERE OPEN/CLOSE ACTION REQUIRED ON INTERLOCK CONDITION



Technical specification for  
**Control Valves with Accessories**  
(Pneumatically Operated)  
**2 X 500MW NEYVELI NEW TPP (NNTPP)**  
**(TG-PKG)**

SPEC NO.: **PE-TS-402-145-I 104**

VOLUME II B

SECTION D

REV. NO. 00 DATE 18.12.14

SHEET 48 OF 128

## SECTION-D

## DATA SHEETS - A&B

<b>BHEL PEM</b>	<b>Technical specification for Control Valves with Accessories (Pneumatically Operated) 2 X 500MW NEYVELI NEW TPP (NNTPP) (TG-PKG)</b>		SPECIFICATION NO.: PE-TS-402-145-1104	
			VOLUME IIB	
			SECTION D	
			REV. NO. 00	DATE : 18.12.2014
		SHEET 49	OF 128	
Tag No. : ...ASV-8...		Qty.: ...1 per Unit ...		Data Sheet No. PES-145-06-DS1-0
<b>DATA SHEET – A &amp; B</b>				
DATA SHEET – A FOR CONTROL VALVE (WITH PNEUMATIC ACTUATOR) (TO BE FILLED BY PURCHASER)			DATA SHEET – B (TO BE FILLED UP BY BIDDER)	
GENERAL	PROJECT	NNTPP-2x500 MW LIGNITE FIRED UNIT AT NEYVELI		.....
	SERVICE	D/A PEGGING FROM AUX. STEAM HEADER		.....
GENERAL	LOCATION	<input checked="" type="checkbox"/> INDOOR <input type="checkbox"/> OUTDOOR		.....
	DUTY	<input type="checkbox"/> ON/OFF <input checked="" type="checkbox"/> MODULATING		.....
	PIPE SIZE (inlet / outlet)	273 x 6.35             508 x 12.7		.....
	PIPE MATERIAL (inlet / outlet)	SA 106 GR B             SA 106 GR B		.....
BODY	MODEL NO.	BIDDER TO SPECIFY		.....
	TYPE OF BODY: GUIDING: NO. OF PORTS	<input checked="" type="checkbox"/> GLOBE <input type="checkbox"/> ANGLE   <input type="checkbox"/> TOP <input checked="" type="checkbox"/> CAGE   ONE		.....
	BODY SIZE: PORT SIZE: DESIGN CV	BIDDER TO SPECIFY		.....
	END CONNECTION & RATING (ANSI)	<input checked="" type="checkbox"/> BWE <input type="checkbox"/> SWE <input type="checkbox"/> FLANGED		.....
	BODY MATERIAL	<input checked="" type="checkbox"/> A216 WCB <input type="checkbox"/> A217 WC6 <input type="checkbox"/> SS <input type="checkbox"/> A217 CS		.....
		<input type="checkbox"/> A351 CF8M		.....
	PACKING: MATERIAL SINGLE / DOUBLE	<input type="checkbox"/> PTFE <input checked="" type="checkbox"/> GRAFOIL : <input type="checkbox"/> DOUBLE <input checked="" type="checkbox"/> SINGLE		.....
	BONNET TYPE	BIDDER TO SPECIFY		.....
	TRIM FORM	<input checked="" type="checkbox"/> LINEAR <input type="checkbox"/> EQ. PERCENTAGE		.....
		<input type="checkbox"/> QUICK OPEN (ON/OFF)		.....
	TRIM MATERIAL: SEAT   PLUG	SS 316 STELLITED   SS 316 STELLITED		.....
: CAGE   GUIDE BUSH	SS 316 STELLITED   SS 316 STELLITED		.....	
FLOW DIRECTION	BIDDER TO SPECIFY		.....	
OUTLET VELOCITY	<input type="checkbox"/> < 7 M/SEC (WATER)   <input checked="" type="checkbox"/> MAC NO. < 1/3 (STM)		.....	
REQUIRED LEAKAGE CLASS	<input type="checkbox"/> II <input type="checkbox"/> III <input checked="" type="checkbox"/> IV <input type="checkbox"/> V <input type="checkbox"/> VI		.....	
NOISE LEVEL (dBA)	LESS THAN 85 dBA		.....	
VACUUM SERVICE	<input type="checkbox"/> YES <input checked="" type="checkbox"/> NO		.....	
ANTI CAVITATION TRIM	<input type="checkbox"/> YES <input checked="" type="checkbox"/> NO		.....	
PNEUMATIC ACTUATOR	MODEL NO. & SIZE	BIDDER TO SPECIFY		.....
	CLOSE AT : OPEN AT (KG/CM2g)	TO SUIT ACTUATOR (AIR TO CLOSE)		.....
	TRAVEL TIME FOR OPEN TO CLOSE, CLOSE TO OPEN	<10 SEC		.....
VALVE POSN. ON ELEC SIGNAL FAILURE	<input checked="" type="checkbox"/> TO OPEN <input type="checkbox"/> STAYPUT <input type="checkbox"/> TO CLOSE		.....	
VALVE POSN. ON SUPPLY AIR FAILURE	<input checked="" type="checkbox"/> STAYPUT		.....	
ACCESSORIES	POSITIONER (SMART)	<input checked="" type="checkbox"/> REQUIRED <input type="checkbox"/> NOT REQUIRED		.....
	AIR FILTER REGULATOR	<input checked="" type="checkbox"/> REQUIRED <input type="checkbox"/> NOT REQUIRED		.....
	AIR LOCK RELAY	<input checked="" type="checkbox"/> REQUIRED <input type="checkbox"/> NOT REQUIRED		.....
	POSITION LIMIT SWITCH	<input type="checkbox"/> REQUIRED <input checked="" type="checkbox"/> NOT REQUIRED		.....
	POSITION TRANSMITTER	PART OF POSITIONER		.....
	SOLENOID VALVE	<input type="checkbox"/> REQUIRED <input checked="" type="checkbox"/> NOT REQUIRED		.....
	E/P CONVERTER	PART OF POSITIONER		.....
	JUNCTION BOX	<input checked="" type="checkbox"/> REQUIRED <input type="checkbox"/> NOT REQUIRED		.....
	HAND WHEEL (SIDE MOUNTED)	<input checked="" type="checkbox"/> REQUIRED		.....
	LOCAL POSITION INDICATOR	<input checked="" type="checkbox"/> REQUIRED		.....
ELECTRO PNEUMATIC POSITIONER	<input type="checkbox"/> REQUIRED <input checked="" type="checkbox"/> NOT REQUIRED		.....	

<b>BHEL PEM</b>	<b>Technical specification for Control Valves with Accessories (Pneumatically Operated) 2 X 500MW NEYVELI NEW TPP (NNTPP) (TG-PKG)</b>						SPECIFICATION NO.: PE-TS-402-145-1104		
							VOLUME IIB		
							SECTION D		
							REV. NO. 00	DATE : 18.12.2014	
SHEET 50 OF 128									
Tag No. : ...ASV-8...			Qty.: ...1 per Unit ...			Data Sheet No. PES-145-06-DS1-0			
<b>DATA SHEET – A &amp; B</b>									
DATA SHEET – A FOR CONTROL VALVE (WITH PNEUMATIC ACTUATOR) (TO BE FILLED BY PURCHASER)							DATA SHEET – B (TO BE FILLED UP BY BIDDER)		
PERFORMANCE OF VALVE	LINEARITY HYSTERESIS SENSITIVITY ACCURACY (OVERALL)			± 1% ± 1% ± 0.5% ± 1%			..... ..... ..... .....		
SERVICE CONDITION	SL. No. +	LOAD	FLOW (T/HR)	INLET PR. KG/CM2(A)	OUTLET PR. KG/CM2(A)	TEMP DEG (C)	CALC ULATED CV	% VLV LIFT	VLV O/L VELOCITY
	1.	7.5% BMCR	12.8	16	1.65	220			
	2.	15% BMCR (COLD)	25.5	16	1.7	220			
	3.	15% BMCR (HOT)	36.7	16	3.7	220			
	VALVE TYPE							<input type="checkbox"/> CAVITATION <input type="checkbox"/> FLASHING <input checked="" type="checkbox"/> HIGH DP	
MAX SHUT OFF PRESS ( KG/CM2g) 20 VALVE DESIGN : PRESS (KG/CM2g)   TEMP (DEG C) 20   250 IBR FORM III-C <input checked="" type="checkbox"/> REQUIRED <input type="checkbox"/> NOT REQUIRED							..... ..... ..... .....		
TOTAL WEIGHT (VALVE + ACTUATOR + ACCESSORIES) Kg							.....		





<b>BHEL</b> <b>PEM</b>	<b>Technical specification for</b> <b>Control Valves with Accessories</b> (Pneumatically Operated) <b>2 X 500MW NEYVELI NEW TPP (NNTPP)</b> <b>(TG-PKG)</b>		SPECIFICATION NO.: PE-TS-402-145-I104	
			VOLUME	IIB
			SECTION D	
			REV. NO.	00
		SHEET	53	OF 128
Tag No. : CDV-22 & CDV-25 Qty.: 2 per Unit (One against each Tag No.) Data Sheet No. PES-145-06-DS1-0				
<b>DATA SHEET – A &amp; B</b>				
DATA SHEET – A FOR CONTROL VALVE (WITH PNEUMATIC ACTUATOR) (TO BE FILLED BY PURCHASER)				DATA SHEET – B (TO BE FILLED UP BY BIDDER)
GENERAL	PROJECT SERVICE	NNTPP–2x500 MW LIGNITE FIRED UNIT AT NEYVELI		.....
	LOCATION DUTY	MAIN CONDENSATE CONTROL <input checked="" type="checkbox"/> INDOOR <input type="checkbox"/> OUTDOOR		.....
	PIPE SIZE (inlet / outlet)	<input type="checkbox"/> ON/OFF <input checked="" type="checkbox"/> MODULATING		.....
	PIPE MATERIAL (inlet / outlet)	406.4 x 12.7   406.4 x 12.7 SA 106 GR B   SA 106 GR B		..... .....
BODY	MODEL NO.	BIDDER TO SPECIFY		.....
	TYPE OF BODY: GUIDING: NO. OF PORTS	<input checked="" type="checkbox"/> GLOBE <input type="checkbox"/> ANGLE   <input type="checkbox"/> TOP <input checked="" type="checkbox"/> CAGE   ONE		..... ..... .....
	BODY SIZE: PORT SIZE: DESIGN CV	BIDDER TO SPECIFY		..... ..... .....
	END CONNECTION & RATING (ANSI)	<input checked="" type="checkbox"/> BWE <input type="checkbox"/> SWE <input type="checkbox"/> FLANGED		.....
	BODY MATERIAL	<input checked="" type="checkbox"/> A216 WCB <input type="checkbox"/> A217 WC6 <input type="checkbox"/> SS <input type="checkbox"/> A217 CS		.....
	PACKING: MATERIAL SINGLE / DOUBLE	<input type="checkbox"/> A351 CF8M		.....
	BONNET TYPE	<input type="checkbox"/> PTFE <input checked="" type="checkbox"/> GRAFOIL : <input type="checkbox"/> DOUBLE <input checked="" type="checkbox"/> SINGLE		..... .....
	TRIM FORM	BIDDER TO SPECIFY		.....
	TRIM MATERIAL: SEAT   PLUG	<input type="checkbox"/> LINEAR <input checked="" type="checkbox"/> EQ. PERCENTAGE		.....
	: CAGE   GUIDE BUSH	<input type="checkbox"/> QUICK OPEN (ON/OFF)		..... .....
	FLOW DIRECTION	SS 316 STELLITED   SS 316 STELLITED		..... .....
	OUTLET VELOCITY	SS 316 STELLITED   SS 316 STELLITED		..... .....
	REQUIRED LEAKAGE CLASS	BIDDER TO SPECIFY		.....
	NOISE LEVEL (dBA)	<input checked="" type="checkbox"/> < 7 M/SEC (WATER)   <input type="checkbox"/> MAC NO. < 1/3(STM)		.....
	VACUUM SERVICE	<input type="checkbox"/> II <input type="checkbox"/> III <input checked="" type="checkbox"/> IV <input type="checkbox"/> V <input type="checkbox"/> VI		.....
	ANTI CAVITATION TRIM	LESS THAN 85 dBA		.....
		<input type="checkbox"/> YES <input checked="" type="checkbox"/> NO		.....
		<input type="checkbox"/> YES <input checked="" type="checkbox"/> NO		.....
PNEUMATIC ACTUATOR	MODEL NO. & SIZE	BIDDER TO SPECIFY		..... .....
	CLOSE AT : OPEN AT (KG/CM2g)	TO SUIT ACTUATOR (AIR TO OPEN)		..... .....
	TRAVEL TIME FOR	<10 SEC		.....
	OPEN TO CLOSE, CLOSE TO OPEN	<input type="checkbox"/> TO OPEN <input type="checkbox"/> STAYPUT <input checked="" type="checkbox"/> TO CLOSE		.....
	VALVE POSN. ON ELEC SIGNAL FAILURE	<input checked="" type="checkbox"/> STAYPUT		.....
	VALVE POSN. ON SUPPLY AIR FAILURE			.....
ACCESSORIES	POSITIONER (SMART)	<input checked="" type="checkbox"/> REQUIRED <input type="checkbox"/> NOT REQUIRED		.....
	AIR FILTER REGULATOR	<input checked="" type="checkbox"/> REQUIRED <input type="checkbox"/> NOT REQUIRED		.....
	AIR LOCK RELAY	<input checked="" type="checkbox"/> REQUIRED <input type="checkbox"/> NOT REQUIRED		.....
	POSITION LIMIT SWITCH	<input type="checkbox"/> REQUIRED <input checked="" type="checkbox"/> NOT REQUIRED		.....
	POSITION TRANSMITTER	PART OF POSITIONER		.....
	SOLENOID VALVE	<input type="checkbox"/> REQUIRED <input checked="" type="checkbox"/> NOT REQUIRED		.....
	E/P CONVERTER	PART OF POSITIONER		.....
	JUNCTION BOX	<input checked="" type="checkbox"/> REQUIRED <input type="checkbox"/> NOT REQUIRED		.....
	HAND WHEEL (SIDE MOUNTED)	<input checked="" type="checkbox"/> REQUIRED		.....
	LOCAL POSITION INDICATOR	<input checked="" type="checkbox"/> REQUIRED		.....
ELECTRO PNEUMATIC POSITIONER	<input type="checkbox"/> REQUIRED <input checked="" type="checkbox"/> NOT REQUIRED		.....	



<b>BHEL PEM</b>	<b>Technical specification for Control Valves with Accessories (Pneumatically Operated) 2 X 500MW NEYVELI NEW TPP (NNTPP) (TG-PKG)</b>		SPECIFICATION NO.: PE-TS-402-145-1104	
			VOLUME IIB	
			SECTION D	
			REV. NO. 00	DATE : 18.12.2014
		SHEET 55	OF 128	
Tag No. : CDV-10, CDV-12 Qty.: 3 per Unit (One against each Tag No.) Data Sheet No. PES-145-06-DS1-0 CDV-14				
<b>DATA SHEET – A &amp; B</b>				
DATA SHEET – A FOR CONTROL VALVE (WITH PNEUMATIC ACTUATOR) (TO BE FILLED BY PURCHASER)			DATA SHEET – B (TO BE FILLED UP BY BIDDER)	
GENERAL	PROJECT	NNTPP-2x500 MW LIGNITE FIRED UNIT AT NEYVELI		.....
	SERVICE	CEP A/B/C MINIMUM RECIRCULATION		.....
	LOCATION	<input checked="" type="checkbox"/> INDOOR <input type="checkbox"/> OUTDOOR		.....
	DUTY	<input type="checkbox"/> ON/OFF <input checked="" type="checkbox"/> MODULATING		.....
	PIPE SIZE (inlet / outlet)	219.1 x 6.35	219.1 x 6.35	.....
	PIPE MATERIAL (inlet / outlet)	SA 106 GR B	SA 106 GR B	.....
BODY	MODEL NO.	BIDDER TO SPECIFY		.....
	TYPE OF BODY: GUIDING: NO. OF PORTS	<input type="checkbox"/> GLOBE <input checked="" type="checkbox"/> ANGLE   <input type="checkbox"/> TOP <input checked="" type="checkbox"/> CAGE   ONE		.....
	BODY SIZE: PORT SIZE: DESIGN CV	BIDDER TO SPECIFY		.....
	END CONNECTION & RATING (ANSI)	<input checked="" type="checkbox"/> BWE <input type="checkbox"/> SWE <input type="checkbox"/> FLANGED		.....
	BODY MATERIAL	<input type="checkbox"/> A216 WCB <input checked="" type="checkbox"/> A217 WC6 <input type="checkbox"/> SS <input type="checkbox"/> A217 CS		.....
		<input type="checkbox"/> A351 CF8M		.....
	PACKING: MATERIAL SINGLE / DOUBLE	<input type="checkbox"/> PTFE <input checked="" type="checkbox"/> GRAFOIL <input checked="" type="checkbox"/> DOUBLE <input type="checkbox"/> SINGLE		.....
	BONNET TYPE	BIDDER TO SPECIFY		.....
	TRIM FORM	<input checked="" type="checkbox"/> LINEAR <input type="checkbox"/> EQ. PERCENTAGE		.....
		<input type="checkbox"/> QUICK OPEN (ON/OFF)		.....
	TRIM MATERIAL: SEAT   PLUG	17-4 PH SS	17-4 PH SS	.....
	: CAGE   GUIDE BUSH	17-4 PH SS	17-4 PH SS	.....
	FLOW	BIDDER TO SPECIFY		.....
	OUTLET VELOCITY	<input checked="" type="checkbox"/> < 7 M/SEC (WATER)   <input type="checkbox"/> MAC NO.< 1/3(STM)		.....
	REQUIRED LEAKAGE CLASS	<input type="checkbox"/> II <input type="checkbox"/> III <input type="checkbox"/> IV <input checked="" type="checkbox"/> V <input type="checkbox"/> VI		.....
	NOISE LEVEL (dBA)	LESS THAN 85 dBA		.....
	VACUUM SERVICE	<input checked="" type="checkbox"/> YES <input type="checkbox"/> NO		.....
	ANTI CAVITATION TRIM	<input checked="" type="checkbox"/> YES <input type="checkbox"/> NO		.....
PNEUMATIC ACTUATOR	MODEL NO. & SIZE	BIDDER TO SPECIFY		.....
	CLOSE AT : OPEN AT (KG/CM2g)	TO SUIT ACTUATOR (AIR TO CLOSE)		.....
	TRAVEL TIME FOR	<10 SEC		.....
	OPEN TO CLOSE, CLOSE TO OPEN			.....
	VALVE POSN. ON ELEC SIGNAL FAILURE	<input checked="" type="checkbox"/> TO OPEN <input type="checkbox"/> STAYPUT <input type="checkbox"/> TO CLOSE		.....
	VALVE POSN. ON SUPPLY AIR FAILURE	<input checked="" type="checkbox"/> STAYPUT		.....
ACCESSORIES	POSITIONER (SMART)	<input checked="" type="checkbox"/> REQUIRED <input type="checkbox"/> NOT REQUIRED		.....
	AIR FILTER REGULATOR	<input checked="" type="checkbox"/> REQUIRED <input type="checkbox"/> NOT REQUIRED		.....
	AIR LOCK RELAY	<input checked="" type="checkbox"/> REQUIRED <input type="checkbox"/> NOT REQUIRED		.....
	POSITION LIMIT SWITCH	<input type="checkbox"/> REQUIRED <input checked="" type="checkbox"/> NOT REQUIRED		.....
	POSITION TRANSMITTER	PART OF POSITIONER		.....
	SOLENOID VALVE	<input type="checkbox"/> REQUIRED <input checked="" type="checkbox"/> NOT REQUIRED		.....
	E/P CONVERTER	PART OF POSITIONER		.....
	JUNCTION BOX	<input checked="" type="checkbox"/> REQUIRED <input type="checkbox"/> NOT REQUIRED		.....
	HAND WHEEL (SIDE MOUNTED)	<input checked="" type="checkbox"/> REQUIRED		.....
	LOCAL POSITION INDICATOR	<input checked="" type="checkbox"/> REQUIRED		.....
ELECTRO PNEUMATIC POSITIONER	<input type="checkbox"/> REQUIRED <input checked="" type="checkbox"/> NOT REQUIRED		.....	





<b>BHEL PEM</b>	<b>Technical specification for Control Valves with Accessories (Pneumatically Operated)</b>						SPECIFICATION NO.: PE-TS-402-145-1104			
	<b>2 X 500MW NEYVELI NEW TPP (NNTPP) (TG-PKG)</b>						VOLUME IIB		SECTION D	
							REV. NO. 00	DATE : 18.12.2014		
	SHEET 58		OF 128							
<p style="text-align: center;">Tag No. : ...CDV-39...                                  Qty.: ...1 per Unit ...                                  Data Sheet No. PES-145-06-DS1-0</p> <p style="text-align: center;"><b>DATA SHEET – A &amp; B</b></p>										
DATA SHEET – A FOR CONTROL VALVE (WITH PNEUMATIC ACTUATOR) (TO BE FILLED BY PURCHASER)									DATA SHEET – B (TO BE FILLED UP BY BIDDER)	
PERFORMANCE OF VALVE	LINEARITY HYSTERESIS SENSITIVITY ACCURACY (OVERALL)						$\pm 1\%$ $\pm 1\%$ $\pm 0.5\%$ $\pm 1\%$		..... ..... ..... .....	
SERVICE CONDITION	SL. No. +	LOAD	FLOW (T/HR)	INLET PR. KG/CM2(A)	OUTLET PR. KG/CM2(A)	TEMP DEG (C)	CALC ULATED CV	% VLV LIFT	VLV O/L VELOCITY	
	1.	MIN.	30	24 TO 33.5	0.3 TO 0.7	47.9 TO 52				
	2.	MAX	300	24 TO 33.5	0.3 TO 0.7	47.9 TO 52				
	VALVE TYPE						<input checked="" type="checkbox"/> CAVITATION <input type="checkbox"/> FLASHING <input checked="" type="checkbox"/> HIGH DP			
	MAX SHUT OFF PRESS ( KG/CM2g)                                  39 VALVE DESIGN : PRESS (KG/CM2g)   TEMP (DEG C)                                  39/VACUUM   55 IBR FORM III-C <input type="checkbox"/> REQUIRED <input checked="" type="checkbox"/> NOT REQUIRED						..... ..... ..... .....			
TOTAL WEIGHT (VALVE + ACTUATOR + ACCESSORIES) Kg							.....			

<b>BHEL PEM</b>	<b>Technical specification for Control Valves with Accessories (Pneumatically Operated)</b>  <b>2 X 500MW NEYVELI NEW TPP (NNTPP) (TG-PKG)</b>		SPECIFICATION NO.: PE-TS-402-145-1104	
			VOLUME IIB	
			SECTION D	
			REV. NO. 00	DATE : 18.12.2014
		SHEET 59	OF 128	
Tag No. : ...CDV-43...		Qty.: ...1 per Unit ...		Data Sheet No. PES-145-06-DS1-0
<b>DATA SHEET – A &amp; B</b>				
DATA SHEET – A FOR CONTROL VALVE (WITH PNEUMATIC ACTUATOR) (TO BE FILLED BY PURCHASER)				DATA SHEET – B (TO BE FILLED UP BY BIDDER)
GENERAL	PROJECT SERVICE	NNTPP-2x500 MW LIGNITE FIRED UNIT AT NEYVELI		.....
	LOCATION	EXCESS RETURN TO CST		.....
DUTY	PIPE SIZE (inlet / outlet)	<input checked="" type="checkbox"/> INDOOR <input type="checkbox"/> OUTDOOR		.....
	PIPE MATERIAL (inlet / outlet)	<input type="checkbox"/> ON/OFF <input checked="" type="checkbox"/> MODULATING		.....
		219.1 x 6.35             219.1 x 6.35		.....
		SA 106 GR B             SA 106 GR B		.....
BODY	MODEL NO.	BIDDER TO SPECIFY		.....
	TYPE OF BODY: GUIDING: NO. OF PORTS	<input checked="" type="checkbox"/> GLOBE <input type="checkbox"/> ANGLE   <input type="checkbox"/> TOP <input checked="" type="checkbox"/> CAGE   ONE		.....
	BODY SIZE: PORT SIZE: DESIGN CV	BIDDER TO SPECIFY		.....
	END CONNECTION & RATING (ANSI)	<input checked="" type="checkbox"/> BWE <input type="checkbox"/> SWE <input type="checkbox"/> FLANGED		.....
	BODY MATERIAL	<input type="checkbox"/> A216 WCB <input checked="" type="checkbox"/> A217 WC6 <input type="checkbox"/> SS <input type="checkbox"/> A217 CS		.....
		<input type="checkbox"/> A351 CF8M		.....
	PACKING: MATERIAL SINGLE / DOUBLE	<input type="checkbox"/> PTFE <input checked="" type="checkbox"/> GRAFOIL : <input type="checkbox"/> DOUBLE <input checked="" type="checkbox"/> SINGLE		.....
	BONNET TYPE	BIDDER TO SPECIFY <input type="checkbox"/> LINEAR <input checked="" type="checkbox"/> EQ.		.....
	TRIM FORM	PERCENTAGE		.....
		<input type="checkbox"/> QUICK OPEN (ON/OFF)		.....
	TRIM MATERIAL: SEAT   PLUG	17-4 PH SS             17-4 PH SS	.....	
	: CAGE   GUIDE BUSH	17-4 PH SS             17-4 PH SS	.....	
	FLOW DIRECTION	BIDDER TO SPECIFY		.....
	OUTLET VELOCITY	<input checked="" type="checkbox"/> < 7 M/SEC (WATER)   <input type="checkbox"/> MAC NO. < 1/3(STM)		.....
	REQUIRED LEAKAGE CLASS	<input type="checkbox"/> II <input type="checkbox"/> III <input type="checkbox"/> IV <input checked="" type="checkbox"/> V <input type="checkbox"/> VI		.....
	NOISE LEVEL (dBA)	LESS THAN 85 dBA		.....
	VACUUM SERVICE	<input type="checkbox"/> YES <input checked="" type="checkbox"/> NO		.....
	ANTI CAVITATION TRIM	<input checked="" type="checkbox"/> YES <input type="checkbox"/> NO		.....
PNEUMATIC ACTUATOR	MODEL NO. & SIZE	BIDDER TO SPECIFY		.....
	CLOSE AT : OPEN AT (KG/CM2g)	TO SUIT ACTUATOR (AIR TO CLOSE)		.....
	TRAVEL TIME FOR	<10 SEC		.....
	OPEN TO CLOSE, CLOSE TO OPEN			.....
	VALVE POSN. ON ELEC SIGNAL FAILURE	<input checked="" type="checkbox"/> TO OPEN <input type="checkbox"/> STAYPUT <input type="checkbox"/> TO CLOSE		.....
	VALVE POSN. ON SUPPLY AIR FAILURE	<input checked="" type="checkbox"/> STAYPUT		.....
ACCESSORIES	POSITIONER (SMART)	<input checked="" type="checkbox"/> REQUIRED <input type="checkbox"/> NOT REQUIRED		.....
	AIR FILTER REGULATOR	<input checked="" type="checkbox"/> REQUIRED <input type="checkbox"/> NOT REQUIRED		.....
	AIR LOCK RELAY	<input checked="" type="checkbox"/> REQUIRED <input type="checkbox"/> NOT REQUIRED		.....
	POSITION LIMIT SWITCH	<input type="checkbox"/> REQUIRED <input checked="" type="checkbox"/> NOT REQUIRED		.....
	POSITION TRANSMITTER	PART OF POSITIONER		.....
	SOLENOID VALVE	<input type="checkbox"/> REQUIRED <input checked="" type="checkbox"/> NOT REQUIRED		.....
	E/P CONVERTER	PART OF POSITIONER		.....
	JUNCTION BOX	<input checked="" type="checkbox"/> REQUIRED <input type="checkbox"/> NOT REQUIRED		.....
	HAND WHEEL (SIDE MOUNTED)	<input checked="" type="checkbox"/> REQUIRED		.....
	LOCAL POSITION INDICATOR	<input checked="" type="checkbox"/> REQUIRED		.....
ELECTRO PNEUMATIC POSITIONER	<input type="checkbox"/> REQUIRED <input checked="" type="checkbox"/> NOT REQUIRED		.....	











<b>BHEL PEM</b>	<b>Technical specification for Control Valves with Accessories (Pneumatically Operated)  2 X 500MW NEYVELI NEW TPP (NNTPP) (TG-PKG)</b>		SPECIFICATION NO.: PE-TS-402-145-1104
			VOLUME IIB
			SECTION D
			REV. NO. 00      DATE : 18.12.2014
			SHEET 65 OF 128
Tag No. : ...DRV-2...		Qty.: ...1 per Unit ...	Data Sheet No. PES-145-06-DS1-0
<b>DATA SHEET – A &amp; B</b>			
DATA SHEET – A FOR CONTROL VALVE (WITH PNEUMATIC ACTUATOR) (TO BE FILLED BY PURCHASER)			DATA SHEET – B (TO BE FILLED UP BY BIDDER)
GENERAL	PROJECT	NNTPP-2x500 MW LIGNITE FIRED UNIT AT NEYVELI	.....
	SERVICE	HPH-6A NORMAL DRAIN TO HPH-5A	.....
LOCATION	DUTY	<input checked="" type="checkbox"/> INDOOR <input type="checkbox"/> OUTDOOR	.....
	DUTY	<input type="checkbox"/> ON/OFF <input checked="" type="checkbox"/> MODULATING	.....
PIPE SIZE (inlet / outlet)	PIPE SIZE (inlet / outlet)	168.3 x 7.11             168.3 x 7.11	.....
	PIPE MATERIAL (inlet / outlet)	SA 106 GR B             SA 106 GR B	..... .....
BODY	MODEL NO.	BIDDER TO SPECIFY	.....
	TYPE OF BODY: GUIDING: NO. OF PORTS	<input checked="" type="checkbox"/> GLOBE <input type="checkbox"/> ANGLE   <input type="checkbox"/> TOP <input checked="" type="checkbox"/> CAGE   ONE	..... ..... .....
	BODY SIZE: PORT SIZE: DESIGN CV	BIDDER TO SPECIFY	..... ..... .....
	END CONNECTION & RATING (ANSI)	<input checked="" type="checkbox"/> BWE <input type="checkbox"/> SWE <input type="checkbox"/> FLANGED	.....
	BODY MATERIAL	<input type="checkbox"/> A216 WCB <input checked="" type="checkbox"/> A217 WC6 <input type="checkbox"/> SS <input type="checkbox"/> A217 CS	.....
	PACKING: MATERIAL SINGLE / DOUBLE	<input type="checkbox"/> A351 CF8M	.....
	BONNET TYPE	<input type="checkbox"/> PTFE <input checked="" type="checkbox"/> GRAFOIL : <input type="checkbox"/> DOUBLE <input checked="" type="checkbox"/> SINGLE	..... .....
	TRIM FORM	BIDDER TO SPECIFY <input checked="" type="checkbox"/> LINEAR <input type="checkbox"/> EQ. PERCENTAGE	.....
	TRIM MATERIAL: SEAT   PLUG	<input type="checkbox"/> QUICK OPEN (ON/OFF)	.....
	: CAGE   GUIDE BUSH	17-4 PH SS             17-4 PH SS	..... .....
	17-4 PH SS             17-4 PH SS	..... .....	
FLOW DIRECTION	BIDDER TO SPECIFY	.....	
OUTLET VELOCITY	<input checked="" type="checkbox"/> < 7 M/SEC (WATER)   <input type="checkbox"/> MAC NO. < 1/3(STM)	.....	
REQUIRED LEAKAGE CLASS	<input type="checkbox"/> II <input type="checkbox"/> III <input checked="" type="checkbox"/> IV <input type="checkbox"/> V <input type="checkbox"/> VI	.....	
NOISE LEVEL (dBA)	LESS THAN 85 dBA	.....	
VACUUM SERVICE	<input type="checkbox"/> YES <input checked="" type="checkbox"/> NO	.....	
ANTI CAVITATION TRIM	<input type="checkbox"/> YES <input checked="" type="checkbox"/> NO	.....	
PNEUMATIC ACTUATOR	MODEL NO. & SIZE	BIDDER TO SPECIFY	..... .....
	CLOSE AT : OPEN AT (KG/CM <sup>2</sup> g)	TO SUIT ACTUATOR (AIR TO OPEN)	..... .....
	TRAVEL TIME FOR OPEN TO CLOSE, CLOSE TO OPEN	<10 SEC	.....
VALVE POSN. ON ELEC SIGNAL FAILURE	<input type="checkbox"/> TO OPEN <input type="checkbox"/> STAYPUT <input checked="" type="checkbox"/> TO CLOSE	.....	
VALVE POSN. ON SUPPLY AIR FAILURE	<input checked="" type="checkbox"/> STAYPUT	.....	
ACCESSORIES	POSITIONER (SMART)	<input checked="" type="checkbox"/> REQUIRED <input type="checkbox"/> NOT REQUIRED	.....
	AIR FILTER REGULATOR	<input checked="" type="checkbox"/> REQUIRED <input type="checkbox"/> NOT REQUIRED	.....
	AIR LOCK RELAY	<input checked="" type="checkbox"/> REQUIRED <input type="checkbox"/> NOT REQUIRED	.....
	POSITION LIMIT SWITCH	<input type="checkbox"/> REQUIRED <input checked="" type="checkbox"/> NOT REQUIRED	.....
	POSITION TRANSMITTER	PART OF POSITIONER	.....
	SOLENOID VALVE	<input checked="" type="checkbox"/> REQUIRED <input type="checkbox"/> NOT REQUIRED	.....
	E/P CONVERTER	PART OF POSITIONER	.....
	JUNCTION BOX	<input checked="" type="checkbox"/> REQUIRED <input type="checkbox"/> NOT REQUIRED	.....
	HAND WHEEL (SIDE MOUNTED)	<input checked="" type="checkbox"/> REQUIRED	.....
	LOCAL POSITION INDICATOR	<input checked="" type="checkbox"/> REQUIRED	.....
ELECTRO PNEUMATIC POSITIONER	<input type="checkbox"/> REQUIRED <input checked="" type="checkbox"/> NOT REQUIRED	.....	

<b>BHEL PEM</b>	<b>Technical specification for Control Valves with Accessories (Pneumatically Operated)</b> <b>2 X 500MW NEYVELI NEW TPP (NNTPP) (TG-PKG)</b>						SPECIFICATION NO.: PE-TS-402-145-1104		
							VOLUME IIB		
							SECTION D		
					REV. NO. 00		DATE : 18.12.2014		
						SHEET 66 OF 128			
Tag No. : ...DRV-2...			Qty.: ...1 per Unit ...			Data Sheet No. PES-145-06-DS1-0			
<b>DATA SHEET – A &amp; B</b>									
DATA SHEET – A FOR CONTROL VALVE (WITH PNEUMATIC ACTUATOR) (TO BE FILLED BY PURCHASER)							DATA SHEET – B (TO BE FILLED UP BY BIDDER)		
PERFORMANCE OF VALVE	LINEARITY HYSTERESIS SENSITIVITY ACCURACY (OVERALL)				± 1% ± 1% ± 0.5% ± 1%		..... ..... .....		
SERVICE CONDITION	SL. No. +	LOAD	FLOW (T/HR)	INLET PR. KG/CM2(A)	OUTLET PR. KG/CM2(A)	TEMP DEG (C)	CALC ULATED CV	% VLV LIFT	VLV O/L VELOCITY
	1.	30% MCR	19.1	14.2	6.3	163.8			
	2.	60% MCR	38	26.83	11.35	190.6			
	3.	100% MCR	76.5	42.4	17.75	211.2			
	4.	VWO	80	44.3	18.4	211.5			
	5.	BMCR / VWO	83.5	42.72	17.9	216.4			
	VALVE TYPE							<input type="checkbox"/> CAVITATION <input checked="" type="checkbox"/> FLASHING <input type="checkbox"/> HIGH DP	
	MAX SHUT OFF PRESS ( KG/CM2g) 54 VALVE DESIGN : PRESS (KG/CM2g)   TEMP (DEG C) 54   220 IBR FORM III-C <input type="checkbox"/> REQUIRED <input checked="" type="checkbox"/> NOT REQUIRED							..... ..... ..... .....	
TOTAL WEIGHT (VALVE + ACTUATOR + ACCESSORIES) Kg							.....		





<b>BHEL PEM</b>	<b>Technical specification for Control Valves with Accessories (Pneumatically Operated) 2 X 500MW NEYVELI NEW TPP (NNTPP) (TG-PKG)</b>		SPECIFICATION NO.: PE-TS-402-145-1104	
			VOLUME IIB	
			SECTION D	
			REV. NO. 00	DATE : 18.12.2014
		SHEET 69	OF 128	
Tag No. : ...DRV-5... Qty.: ...1 per Unit ... Data Sheet No. PES-145-06-DS1-0				
<b>DATA SHEET – A &amp; B</b>				
DATA SHEET – A FOR CONTROL VALVE (WITH PNEUMATIC ACTUATOR) (TO BE FILLED BY PURCHASER)			DATA SHEET – B (TO BE FILLED UP BY BIDDER)	
GENERAL	PROJECT	NNTPP-2x500 MW LIGNITE FIRED UNIT AT NEYVELI		.....
	SERVICE	HPH-6A ALT. DRAIN TO HP DRAIN F/T		.....
	LOCATION	<input checked="" type="checkbox"/> INDOOR <input type="checkbox"/> OUTDOOR		.....
	DUTY	<input type="checkbox"/> ON/OFF <input checked="" type="checkbox"/> MODULATING		.....
	PIPE SIZE (inlet / outlet)	168.3 x 7.11	219.1 x 8.18	.....
	PIPE MATERIAL (inlet / outlet)	SA 106 GR B	SA 106 GR C	.....
BODY	MODEL NO.	BIDDER TO SPECIFY		.....
	TYPE OF BODY: GUIDING: NO. OF PORTS	<input checked="" type="checkbox"/> GLOBE <input type="checkbox"/> ANGLE   <input type="checkbox"/> TOP <input checked="" type="checkbox"/> CAGE   ONE		.....
	BODY SIZE: PORT SIZE: DESIGN CV	BIDDER TO SPECIFY		.....
	END CONNECTION & RATING (ANSI)	<input checked="" type="checkbox"/> BWE <input type="checkbox"/> SWE <input type="checkbox"/> FLANGED		.....
	BODY MATERIAL	<input type="checkbox"/> A216 WCB <input checked="" type="checkbox"/> A217 WC9 <input type="checkbox"/> SS <input type="checkbox"/> A217 CS		.....
		<input type="checkbox"/> A351 CF8M		.....
	PACKING: MATERIAL SINGLE / DOUBLE	<input type="checkbox"/> PTFE <input checked="" type="checkbox"/> GRAFOIL : <input checked="" type="checkbox"/> DOUBLE <input type="checkbox"/> SINGLE		.....
	BONNET TYPE	BIDDER TO SPECIFY <input checked="" type="checkbox"/> LINEAR <input type="checkbox"/> EQ.		.....
	TRIM FORM	PERCENTAGE		.....
		<input type="checkbox"/> QUICK OPEN (ON/OFF)		.....
	TRIM MATERIAL: SEAT   PLUG	440 C	440 C	.....
	: CAGE   GUIDE BUSH	440 C	440 C	.....
	FLOW DIRECTION	BIDDER TO SPECIFY		.....
	OUTLET VELOCITY	<input checked="" type="checkbox"/> < 7 M/SEC (WATER)   <input type="checkbox"/> MAC NO. < 1/3(STM)		.....
	REQUIRED LEAKAGE CLASS	<input type="checkbox"/> II <input type="checkbox"/> III <input type="checkbox"/> IV <input checked="" type="checkbox"/> V <input type="checkbox"/> VI		.....
	NOISE LEVEL (dBA)	LESS THAN 85 dBA		.....
	VACUUM SERVICE	<input checked="" type="checkbox"/> YES <input type="checkbox"/> NO		.....
	ANTI CAVITATION TRIM	<input checked="" type="checkbox"/> YES <input type="checkbox"/> NO		.....
PNEUMATIC ACTUATOR	MODEL NO. & SIZE	BIDDER TO SPECIFY		.....
	CLOSE AT : OPEN AT (KG/CM2g)	TO SUIT ACTUATOR (AIR TO CLOSE)		.....
	TRAVEL TIME FOR OPEN TO CLOSE, CLOSE TO OPEN	<10 SEC		.....
	VALVE POSN. ON ELEC SIGNAL FAILURE	<input checked="" type="checkbox"/> TO OPEN <input type="checkbox"/> STAYPUT <input type="checkbox"/> TO CLOSE		.....
	VALVE POSN. ON SUPPLY AIR FAILURE	<input checked="" type="checkbox"/> STAYPUT		.....
ACCESSORIES	POSITIONER (SMART)	<input checked="" type="checkbox"/> REQUIRED <input type="checkbox"/> NOT REQUIRED		.....
	AIR FILTER REGULATOR	<input checked="" type="checkbox"/> REQUIRED <input type="checkbox"/> NOT REQUIRED		.....
	AIR LOCK RELAY	<input checked="" type="checkbox"/> REQUIRED <input type="checkbox"/> NOT REQUIRED		.....
	POSITION LIMIT SWITCH	<input type="checkbox"/> REQUIRED <input checked="" type="checkbox"/> NOT REQUIRED		.....
	POSITION TRANSMITTER	PART OF POSITIONER		.....
	SOLENOID VALVE	<input checked="" type="checkbox"/> REQUIRED <input type="checkbox"/> NOT REQUIRED		.....
	E/P CONVERTER	PART OF POSITIONER		.....
	JUNCTION BOX	<input checked="" type="checkbox"/> REQUIRED <input type="checkbox"/> NOT REQUIRED		.....
	HAND WHEEL (SIDE MOUNTED)	<input checked="" type="checkbox"/> REQUIRED		.....
	LOCAL POSITION INDICATOR	<input checked="" type="checkbox"/> REQUIRED		.....
ELECTRO PNEUMATIC POSITIONER	<input type="checkbox"/> REQUIRED <input checked="" type="checkbox"/> NOT REQUIRED		.....	









<b>BHEL PEM</b>	<b>Technical specification for Control Valves with Accessories (Pneumatically Operated)</b>					SPECIFICATION NO.: PE-TS-402-145-1104					
	<b>2 X 500MW NEYVELI NEW TPP (NNTPP) (TG-PKG)</b>					VOLUME IIB					
						SECTION D					
	REV. NO. 00		DATE : 18.12.2014								
					SHEET 74		OF 128				
Tag No. : ...DRV-15...			Qty.: ...1 per Unit ...			Data Sheet No. PES-145-06-DS1-0					
<b>DATA SHEET – A &amp; B</b>											
DATA SHEET – A FOR CONTROL VALVE (WITH PNEUMATIC ACTUATOR) (TO BE FILLED BY PURCHASER)								DATA SHEET – B (TO BE FILLED UP BY BIDDER)			
PERFORMANCE OF VALVE	LINEARITY HYSTERISIS SENSITIVITY ACCURACY (OVERALL)				± 1% ± 1% ± 0.5% ± 1%			..... ..... .....			
SERVICE CONDITION	SL. No. +	LOAD	FLOW (T/HR)	INLET PR. KG/CM2(A)	OUTLET PR. KG/CM2(A)	TEMP DEG (C)	CALC ULATED CV	% VLV LIFT	VLV O/L VELOCITY		
	1.	30% MCR	27.7	4.8	4.0	143.8					
	2.	60% MCR	65	9.25	4.84	149.2					
	3.	100% MCR	124	15.35	7	167.8					
	4.	VWO	129	15.84	7.19	169					
	5.	BMCR / VWO	135	15.4	6.9	167.9					
	VALVE TYPE							<input type="checkbox"/> CAVITATION <input checked="" type="checkbox"/> FLASHING <input type="checkbox"/> HIGH DP			
	MAX SHUT OFF PRESS ( KG/CM2g) 22 VALVE DESIGN : PRESS (KG/CM2g)   TEMP (DEG C) 22   180 IBR FORM III-C <input type="checkbox"/> REQUIRED <input checked="" type="checkbox"/> NOT REQUIRED							..... ..... ..... .....			
TOTAL WEIGHT (VALVE + ACTUATOR + ACCESSORIES) Kg							.....				

<b>BHEL PEM</b>	Technical specification for <b>Control Valves with Accessories</b> (Pneumatically Operated) <b>2 X 500MW NEYVELI NEW TPP (NNTPP)</b> (TG-PKG)		SPECIFICATION NO.: PE-TS-402-145-1104		
			VOLUME	IIB	
			SECTION	D	
			REV. NO.	00	DATE : 18.12.2014
			SHEET	75	OF 128
Tag No. : ...DRV-22...		Qty.: ...1 per Unit ...		Data Sheet No. PES-145-06-DS1-0	
<b>DATA SHEET – A &amp; B</b>					
<b>DATA SHEET – A FOR CONTROL VALVE (WITH PNEUMATIC ACTUATOR)</b> (TO BE FILLED BY PURCHASER)			<b>DATA SHEET – B</b> (TO BE FILLED UP BY BIDDER)		
<b>GENERAL</b>	PROJECT SERVICE	NNTPP-2x500 MW LIGNITE FIRED UNIT AT NEYVELI			
	LOCATION	HPH-5B NORMAL DRAIN TO DEAERATOR			
<b>BODY</b>	DUTY	<input checked="" type="checkbox"/> INDOOR <input type="checkbox"/> OUTDOOR <input type="checkbox"/> ON/OFF <input checked="" type="checkbox"/> MODULATING			
	PIPE SIZE (inlet / outlet)	219.1 x 6.35   219.1 x 8.18			
	PIPE MATERIAL (inlet / outlet)	SA 106 GR B   SA 106 GR C			
	MODEL NO.	BIDDER TO SPECIFY			
TYPE OF BODY: GUIDING: NO. OF PORTS	<input checked="" type="checkbox"/> GLOBE <input type="checkbox"/> ANGLE   <input type="checkbox"/> TOP <input checked="" type="checkbox"/> CAGE   ONE				
BODY SIZE: PORT SIZE: DESIGN CV	BIDDER TO SPECIFY				
END CONNECTION & RATING (ANSI)	<input checked="" type="checkbox"/> BWE <input type="checkbox"/> SWE <input type="checkbox"/> FLANGED <input type="checkbox"/> A216 WCB <input checked="" type="checkbox"/> A217 WC6 <input type="checkbox"/> SS <input type="checkbox"/> A217 CS <input type="checkbox"/> A351 CF8M				
BODY MATERIAL	<input type="checkbox"/> PTFE <input checked="" type="checkbox"/> GRAFOIL : <input type="checkbox"/> DOUBLE <input checked="" type="checkbox"/> SINGLE BIDDER TO SPECIFY				
PACKING: MATERIAL SINGLE / DOUBLE	<input checked="" type="checkbox"/> LINEAR <input type="checkbox"/> EQ. PERCENTAGE <input type="checkbox"/> QUICK OPEN (ON/OFF)				
BONNET TYPE	17-4 PH SS   17-4 PH SS				
TRIM FORM	17-4 PH SS   17-4 PH SS				
TRIM MATERIAL: SEAT   PLUG	BIDDER TO SPECIFY				
: CAGE   GUIDE BUSH	<input checked="" type="checkbox"/> < 7 M/SEC (WATER)   <input type="checkbox"/> MAC NO. < 1/3(STM) <input type="checkbox"/> II <input type="checkbox"/> III <input checked="" type="checkbox"/> IV <input type="checkbox"/> V <input type="checkbox"/> VI LESS THAN 85 dBA <input type="checkbox"/> YES <input checked="" type="checkbox"/> NO <input type="checkbox"/> YES <input checked="" type="checkbox"/> NO				
FLOW DIRECTION					
OUTLET VELOCITY					
REQUIRED LEAKAGE CLASS					
NOISE LEVEL (dBA)					
VACUUM SERVICE					
ANTI CAVITATION TRIM					
<b>PNEUMATIC ACTUATOR</b>	MODEL NO. & SIZE	BIDDER TO SPECIFY			
	CLOSE AT : OPEN AT (KG/CM2g)	TO SUIT ACTUATOR (AIR TO OPEN)			
	TRAVEL TIME FOR	<10 SEC			
	OPEN TO CLOSE, CLOSE TO OPEN	<input type="checkbox"/> TO OPEN <input type="checkbox"/> STAYPUT <input checked="" type="checkbox"/> TO CLOSE <input checked="" type="checkbox"/> STAYPUT			
VALVE POSN. ON ELEC SIGNAL FAILURE					
VALVE POSN. ON SUPPLY AIR FAILURE					
<b>ACCESSORIES</b>	POSITIONER (SMART)	<input checked="" type="checkbox"/> REQUIRED <input type="checkbox"/> NOT REQUIRED			
	AIR FILTER REGULATOR	<input checked="" type="checkbox"/> REQUIRED <input type="checkbox"/> NOT REQUIRED			
	AIR LOCK RELAY	<input checked="" type="checkbox"/> REQUIRED <input type="checkbox"/> NOT REQUIRED			
	POSITION LIMIT SWITCH	<input type="checkbox"/> REQUIRED <input checked="" type="checkbox"/> NOT REQUIRED			
	POSITION TRANSMITTER	PART OF POSITIONER			
	SOLENOID VALVE	<input checked="" type="checkbox"/> REQUIRED <input type="checkbox"/> NOT REQUIRED			
	E/P CONVERTER	PART OF POSITIONER			
	JUNCTION BOX	<input checked="" type="checkbox"/> REQUIRED <input type="checkbox"/> NOT REQUIRED			
	HAND WHEEL (SIDE MOUNTED)	<input checked="" type="checkbox"/> REQUIRED			
	LOCAL POSITION INDICATOR	<input checked="" type="checkbox"/> REQUIRED			
	ELECTRO PNEUMATIC POSITIONER	<input type="checkbox"/> REQUIRED <input checked="" type="checkbox"/> NOT REQUIRED			



<b>BHEL PEM</b>	<b>Technical specification for Control Valves with Accessories (Pneumatically Operated)</b>  <b>2 X 500MW NEYVELI NEW TPP (NNTPP) (TG-PKG)</b>		SPECIFICATION NO.: PE-TS-402-145-1104	
			VOLUME IIB	
			SECTION D	
			REV. NO. 00	DATE : 18.12.2014
		SHEET 77	OF 128	
Tag No. : ...DRV-18...		Qty.: ...1 per Unit ...		Data Sheet No. PES-145-06-DS1-0
<b>DATA SHEET – A &amp; B</b>				
DATA SHEET – A FOR CONTROL VALVE (WITH PNEUMATIC ACTUATOR) (TO BE FILLED BY PURCHASER)				DATA SHEET – B (TO BE FILLED UP BY BIDDER)
GENERAL	PROJECT SERVICE	NNTPP-2x500 MW LIGNITE FIRED UNIT AT NEYVELI		.....
	LOCATION	HPH-5A ALT. DRAIN TO HPD F/T		.....
BODY	DUTY	<input checked="" type="checkbox"/> INDOOR <input type="checkbox"/> OUTDOOR		.....
	PIPE SIZE (inlet / outlet)	<input type="checkbox"/> ON/OFF <input checked="" type="checkbox"/> MODULATING		.....
	PIPE MATERIAL (inlet / outlet)	219.1 x 6.35             273 x 9.27		.....
		SA 106 GR B             SA 106 GR C		.....
BODY	MODEL NO.	BIDDER TO SPECIFY		.....
	TYPE OF BODY: GUIDING: NO. OF PORTS	<input checked="" type="checkbox"/> GLOBE <input type="checkbox"/> ANGLE   <input type="checkbox"/> TOP <input checked="" type="checkbox"/> CAGE   ONE		.....
	BODY SIZE: PORT SIZE: DESIGN CV	BIDDER TO SPECIFY		.....
	END CONNECTION & RATING (ANSI)	<input checked="" type="checkbox"/> BWE <input type="checkbox"/> SWE <input type="checkbox"/> FLANGED		.....
	BODY MATERIAL	<input type="checkbox"/> A216 WCB <input checked="" type="checkbox"/> A217 WC9 <input type="checkbox"/> SS <input type="checkbox"/> A217 CS		.....
		<input type="checkbox"/> A351 CF8M		.....
	PACKING: MATERIAL SINGLE / DOUBLE	<input type="checkbox"/> PTFE <input checked="" type="checkbox"/> GRAFOIL : <input checked="" type="checkbox"/> DOUBLE <input type="checkbox"/> SINGLE		.....
	BONNET TYPE	BIDDER TO SPECIFY		.....
	TRIM FORM	<input checked="" type="checkbox"/> LINEAR <input type="checkbox"/> EQ. PERCENTAGE		.....
	TRIM MATERIAL: SEAT   PLUG	<input type="checkbox"/> QUICK OPEN (ON/OFF)		.....
	440 C             440 C		.....	
	440 C             440 C		.....	
	FLOW DIRECTION	BIDDER TO SPECIFY		.....
	OUTLET VELOCITY	<input checked="" type="checkbox"/> < 7 M/SEC (WATER)   <input type="checkbox"/> MAC NO. < 1/3(STM)		.....
	REQUIRED LEAKAGE CLASS	<input type="checkbox"/> II <input type="checkbox"/> III <input type="checkbox"/> IV <input checked="" type="checkbox"/> V <input type="checkbox"/> VI		.....
	NOISE LEVEL (dBA)	LESS THAN 85 dBA		.....
	VACUUM SERVICE	<input checked="" type="checkbox"/> YES <input type="checkbox"/> NO		.....
	ANTI CAVITATION TRIM	<input checked="" type="checkbox"/> YES <input type="checkbox"/> NO		.....
PNEUMATIC ACTUATOR	MODEL NO. & SIZE	BIDDER TO SPECIFY		.....
	CLOSE AT : OPEN AT (KG/CM2g)	TO SUIT ACTUATOR (AIR TO CLOSE)		.....
	TRAVEL TIME FOR	<10 SEC		.....
	OPEN TO CLOSE, CLOSE TO OPEN	<input checked="" type="checkbox"/> TO OPEN <input type="checkbox"/> STAYPUT <input type="checkbox"/> TO CLOSE		.....
VALVE POSN. ON ELEC SIGNAL FAILURE	<input checked="" type="checkbox"/> STAYPUT		.....	
VALVE POSN. ON SUPPLY AIR FAILURE			.....	
ACCESSORIES	POSITIONER (SMART)	<input checked="" type="checkbox"/> REQUIRED <input type="checkbox"/> NOT REQUIRED		.....
	AIR FILTER REGULATOR	<input checked="" type="checkbox"/> REQUIRED <input type="checkbox"/> NOT REQUIRED		.....
	AIR LOCK RELAY	<input checked="" type="checkbox"/> REQUIRED <input type="checkbox"/> NOT REQUIRED		.....
	POSITION LIMIT SWITCH	<input type="checkbox"/> REQUIRED <input checked="" type="checkbox"/> NOT REQUIRED		.....
	POSITION TRANSMITTER	PART OF POSITIONER		.....
	SOLENOID VALVE	<input checked="" type="checkbox"/> REQUIRED <input type="checkbox"/> NOT REQUIRED		.....
	E/P CONVERTER	PART OF POSITIONER		.....
	JUNCTION BOX	<input checked="" type="checkbox"/> REQUIRED <input type="checkbox"/> NOT REQUIRED		.....
	HAND WHEEL (SIDE MOUNTED)	<input checked="" type="checkbox"/> REQUIRED		.....
	LOCAL POSITION INDICATOR	<input checked="" type="checkbox"/> REQUIRED		.....
ELECTRO PNEUMATIC POSITIONER	<input type="checkbox"/> REQUIRED <input checked="" type="checkbox"/> NOT REQUIRED		.....	



<b>BHEL PEM</b>	<b>Technical specification for Control Valves with Accessories (Pneumatically Operated)</b>  <b>2 X 500MW NEYVELI NEW TPP (NNTPP) (TG-PKG)</b>		SPECIFICATION NO.: PE-TS-402-145-1104	
			VOLUME IIB	
			SECTION D	
			REV. NO. 00	DATE : 18.12.2014
		SHEET 79	OF 128	
Tag No. : ...DRV-25...                      Qty.: ...1 per Unit ...                      Data Sheet No. PES-145-06-DS1-0  <b>DATA SHEET – A &amp; B</b>				
<b>DATA SHEET – A FOR CONTROL VALVE (WITH PNEUMATIC ACTUATOR) (TO BE FILLED BY PURCHASER)</b>			<b>DATA SHEET – B (TO BE FILLED UP BY BIDDER)</b>	
GENERAL	PROJECT	NNTPP-2x500 MW LIGNITE FIRED UNIT AT NEYVELI		.....
	SERVICE	HPH-5B ALT. DRAIN TO HPD F/T		.....
LOCATION	DUTY	<input checked="" type="checkbox"/> INDOOR <input type="checkbox"/> OUTDOOR <input type="checkbox"/> ON/OFF <input checked="" type="checkbox"/> MODULATING		.....
	PIPE SIZE (inlet / outlet)	219.1 x 6.35                                             273 x 9.27		.....
	PIPE MATERIAL (inlet / outlet)	SA 106 GR B                                             SA 106 GR C		.....
BODY	MODEL NO.	BIDDER TO SPECIFY		.....
	TYPE OF BODY: GUIDING: NO. OF PORTS	<input checked="" type="checkbox"/> GLOBE <input type="checkbox"/> ANGLE   <input type="checkbox"/> TOP <input checked="" type="checkbox"/> CAGE   ONE		.....
	BODY SIZE: PORT SIZE: DESIGN CV	BIDDER TO SPECIFY		.....
	END CONNECTION & RATING (ANSI)	<input checked="" type="checkbox"/> BWE <input type="checkbox"/> SWE <input type="checkbox"/> FLANGED <input type="checkbox"/> A216 WCB <input checked="" type="checkbox"/> A217 WC9 <input type="checkbox"/> SS <input type="checkbox"/> A217 CS <input type="checkbox"/> A351 CF8M		.....
	BODY MATERIAL	<input type="checkbox"/> PTFE <input checked="" type="checkbox"/> GRAFOIL <input checked="" type="checkbox"/> DOUBLE <input type="checkbox"/> SINGLE BIDDER TO SPECIFY		.....
	PACKING: MATERIAL SINGLE / DOUBLE	<input checked="" type="checkbox"/> LINEAR <input type="checkbox"/> EQ. PERCENTAGE <input type="checkbox"/> QUICK OPEN (ON/OFF)		.....
	BONNET TYPE	440 C                                             440 C		.....
	TRIM FORM	440 C                                             440 C		.....
	TRIM MATERIAL: SEAT   PLUG	BIDDER TO SPECIFY		.....
	: CAGE   GUIDE BUSH	<input checked="" type="checkbox"/> < 7 M/SEC (WATER)   <input type="checkbox"/> MAC NO. < 1/3(STM) <input type="checkbox"/> II <input type="checkbox"/> III <input type="checkbox"/> IV <input checked="" type="checkbox"/> V <input type="checkbox"/> VI LESS THAN 85 dBA <input checked="" type="checkbox"/> YES <input type="checkbox"/> NO <input checked="" type="checkbox"/> YES <input type="checkbox"/> NO		.....
FLOW DIRECTION			.....	
OUTLET VELOCITY			.....	
REQUIRED LEAKAGE CLASS			.....	
NOISE LEVEL (dBA)			.....	
VACUUM SERVICE			.....	
ANTI CAVITATION TRIM			.....	
PNEUMATIC ACTUATOR	MODEL NO. & SIZE	BIDDER TO SPECIFY		.....
	CLOSE AT : OPEN AT (KG/CM2g)	TO SUIT ACTUATOR (AIR TO CLOSE)		.....
	TRAVEL TIME FOR	<10 SEC		.....
OPEN TO CLOSE, CLOSE TO OPEN			.....	
VALVE POSN. ON ELEC SIGNAL FAILURE	<input checked="" type="checkbox"/> TO OPEN <input type="checkbox"/> STAYPUT <input type="checkbox"/> TO CLOSE <input checked="" type="checkbox"/> STAYPUT		.....	
VALVE POSN. ON SUPPLY AIR FAILURE			.....	
ACCESSORIES	POSITIONER (SMART)	<input checked="" type="checkbox"/> REQUIRED <input type="checkbox"/> NOT REQUIRED		.....
	AIR FILTER REGULATOR	<input checked="" type="checkbox"/> REQUIRED <input type="checkbox"/> NOT REQUIRED		.....
	AIR LOCK RELAY	<input checked="" type="checkbox"/> REQUIRED <input type="checkbox"/> NOT REQUIRED		.....
	POSITION LIMIT SWITCH	<input type="checkbox"/> REQUIRED <input checked="" type="checkbox"/> NOT REQUIRED		.....
	POSITION TRANSMITTER	PART OF POSITIONER		.....
	SOLENOID VALVE	<input checked="" type="checkbox"/> REQUIRED <input type="checkbox"/> NOT REQUIRED		.....
	E/P CONVERTER	PART OF POSITIONER		.....
	JUNCTION BOX	<input checked="" type="checkbox"/> REQUIRED <input type="checkbox"/> NOT REQUIRED		.....
	HAND WHEEL (SIDE MOUNTED)	<input checked="" type="checkbox"/> REQUIRED		.....
	LOCAL POSITION INDICATOR	<input checked="" type="checkbox"/> REQUIRED		.....
ELECTRO PNEUMATIC POSITIONER	<input type="checkbox"/> REQUIRED <input checked="" type="checkbox"/> NOT REQUIRED		.....	



<b>BHEL PEM</b>	<b>Technical specification for Control Valves with Accessories (Pneumatically Operated) 2 X 500MW NEYVELI NEW TPP (NNTPP) (TG-PKG)</b>		SPECIFICATION NO.: PE-TS-402-145-1104	
			VOLUME IIB	
			SECTION D	
			REV. NO. 00	DATE : 18.12.2014
		SHEET 81	OF 128	
Tag No. : ...DRV-28...		Qty.: ...1 per Unit ...		Data Sheet No. PES-145-06-DS1-0
<b>DATA SHEET – A &amp; B</b>				
DATA SHEET – A FOR CONTROL VALVE (WITH PNEUMATIC ACTUATOR) (TO BE FILLED BY PURCHASER)				DATA SHEET – B (TO BE FILLED UP BY BIDDER)
GENERAL	PROJECT SERVICE	NNTPP-2x500 MW LIGNITE FIRED UNIT AT NEYVELI		.....
	LOCATION	LPH-3 NORMAL DRAIN TO LPH-2		.....
BODY	DUTY	<input checked="" type="checkbox"/> INDOOR <input type="checkbox"/> OUTDOOR		.....
	PIPE SIZE (inlet / outlet)	<input type="checkbox"/> ON/OFF <input checked="" type="checkbox"/> MODULATING		.....
	PIPE MATERIAL (inlet / outlet)	168.3 x 7.11   168.3 x 7.11		.....
		SA 106 GR B   SA 106 GR B		.....
BODY	MODEL NO.	BIDDER TO SPECIFY		.....
	TYPE OF BODY: GUIDING: NO. OF PORTS	<input checked="" type="checkbox"/> GLOBE <input type="checkbox"/> ANGLE   <input type="checkbox"/> TOP <input checked="" type="checkbox"/> CAGE   ONE		.....
	BODY SIZE: PORT SIZE: DESIGN CV	BIDDER TO SPECIFY		.....
	END CONNECTION & RATING (ANSI)	<input checked="" type="checkbox"/> BWE <input type="checkbox"/> SWE <input type="checkbox"/> FLANGED		.....
	BODY MATERIAL	<input type="checkbox"/> A216 WCB <input checked="" type="checkbox"/> A217 WC6 <input type="checkbox"/> SS <input type="checkbox"/> A217 CS		.....
		<input type="checkbox"/> A351 CF8M		.....
	PACKING: MATERIAL SINGLE / DOUBLE	<input type="checkbox"/> PTFE <input checked="" type="checkbox"/> GRAFOIL <input checked="" type="checkbox"/> DOUBLE <input type="checkbox"/> SINGLE		.....
	BONNET TYPE	BIDDER TO SPECIFY		.....
	TRIM FORM	<input checked="" type="checkbox"/> LINEAR <input type="checkbox"/> EQ. PERCENTAGE		.....
	TRIM MATERIAL: SEAT   PLUG : CAGE   GUIDE BUSH	<input type="checkbox"/> QUICK OPEN (ON/OFF)		.....
PNEUMATIC ACTUATOR	MODEL NO. & SIZE	BIDDER TO SPECIFY		.....
	CLOSE AT : OPEN AT (KG/CM2g)	TO SUIT ACTUATOR (AIR TO OPEN)		.....
	TRAVEL TIME FOR	<10 SEC		.....
	OPEN TO CLOSE, CLOSE TO OPEN			.....
	VALVE POSN. ON ELEC SIGNAL FAILURE	<input type="checkbox"/> TO OPEN <input type="checkbox"/> STAYPUT <input checked="" type="checkbox"/> TO CLOSE		.....
	VALVE POSN. ON SUPPLY AIR FAILURE	<input checked="" type="checkbox"/> STAYPUT		.....
				.....
ACCESSORIES	POSITIONER (SMART)	<input checked="" type="checkbox"/> REQUIRED <input type="checkbox"/> NOT REQUIRED		.....
	AIR FILTER REGULATOR	<input checked="" type="checkbox"/> REQUIRED <input type="checkbox"/> NOT REQUIRED		.....
	AIR LOCK RELAY	<input checked="" type="checkbox"/> REQUIRED <input type="checkbox"/> NOT REQUIRED		.....
	POSITION LIMIT SWITCH	<input type="checkbox"/> REQUIRED <input checked="" type="checkbox"/> NOT REQUIRED		.....
	POSITION TRANSMITTER	PART OF POSITIONER		.....
	SOLENOID VALVE	<input checked="" type="checkbox"/> REQUIRED <input type="checkbox"/> NOT REQUIRED		.....
	E/P CONVERTER	PART OF POSITIONER		.....
	JUNCTION BOX	<input checked="" type="checkbox"/> REQUIRED <input type="checkbox"/> NOT REQUIRED		.....
	HAND WHEEL (SIDE MOUNTED)	<input checked="" type="checkbox"/> REQUIRED		.....
	LOCAL POSITION INDICATOR	<input checked="" type="checkbox"/> REQUIRED		.....
ELECTRO PNEUMATIC POSITIONER	<input type="checkbox"/> REQUIRED <input checked="" type="checkbox"/> NOT REQUIRED		.....	









<b>BHEL</b> <b>PEM</b>	<b>Technical specification for</b> <b>Control Valves with Accessories</b> (Pneumatically Operated) <b>2 X 500MW NEYVELI NEW TPP (NNTPP)</b> <b>(TG-PKG)</b>					SPECIFICATION NO.: PE-TS-402-145-1104				
						VOLUME IIB				
						SECTION D				
						REV. NO. 00		DATE : 18.12.2014		
					SHEET 86		OF 128			
Tag No. : ...DRV-34...                      Qty.: ...1 per Unit ...                      Data Sheet No. PES-145-06-DS1-0  <b>DATA SHEET – A &amp; B</b>										
<b>DATA SHEET – A FOR CONTROL VALVE (WITH PNEUMATIC ACTUATOR)</b> (TO BE FILLED BY PURCHASER)								<b>DATA SHEET – B</b> (TO BE FILLED UP BY BIDDER)		
PERFORMANCE OF VALVE	LINEARITY HYSTERISIS SENSITIVITY ACCURACY (OVERALL)				$\pm 1\%$ $\pm 1\%$ $\pm 0.5\%$ $\pm 1\%$		..... ..... ..... .....			
<b>SERVICE</b> <b>CONDITION</b>	SL. No. +	LOAD	FLOW (T/HR)	INLET PR. KG/CM2(A)	OUTLET PR. KG/CM2(A)	TEMP DEG (C)	CALC ULATED CV	% VLV LIFT	VLV O/L VELOCITY	
	1.	30% MCR	37	0.6	0.3	53.6				
	2.	60% MCR	64	0.8	0.4	63.3				
	3.	100% MCR	114	1.2	0.5	72.7				
	4.	VWO	118	1.2	0.55	73.2				
	5.	BOTH HPH OUT	125	1.2	0.55	74.6				
	VALVE TYPE							<input type="checkbox"/> CAVITATION <input checked="" type="checkbox"/> FLASHING <input type="checkbox"/> HIGH DP		
	MAX SHUT OFF PRESS ( KG/CM2g)                      7 VALVE DESIGN : PRESS (KG/CM2g)   TEMP (DEG C)                      7/VACUUM   85 IBR FORM III-C <input type="checkbox"/> REQUIRED <input checked="" type="checkbox"/> NOT REQUIRED							..... ..... ..... .....		
TOTAL WEIGHT (VALVE + ACTUATOR + ACCESSORIES) Kg							.....			



<b>BHEL PEM</b>	<b>Technical specification for Control Valves with Accessories (Pneumatically Operated)</b>					SPECIFICATION NO.: PE-TS-402-145-1104				
	<b>2 X 500MW NEYVELI NEW TPP (NNTPP) (TG-PKG)</b>					VOLUME IIB				
						SECTION D				
	REV. NO. 00		DATE : 18.12.2014			SHEET 88 OF 128				
Tag No. : ...DRV-37...                      Qty.: ...1 per Unit ...                      Data Sheet No. PES-145-06-DS1-0  <b>DATA SHEET – A &amp; B</b>										
DATA SHEET – A FOR CONTROL VALVE (WITH PNEUMATIC ACTUATOR) (TO BE FILLED BY PURCHASER)								DATA SHEET – B (TO BE FILLED UP BY BIDDER)		
PERFORMANCE OF VALVE	LINEARITY HYSTERISIS SENSITIVITY ACCURACY (OVERALL)				± 1% ± 1% ± 0.5% ± 1%		..... ..... .....			
SERVICE CONDITION	SL. No. +	LOAD	FLOW (T/HR)	INLET PR. KG/CM2(A)	OUTLET PR. KG/CM2(A)	TEMP DEG (C)	CALC ULATED CV	% VLV LIFT	VLV O/L VELOCITY	
	1.	30% MCR	37	1.0	0.3 TO 0.5	84.3				
	2.	60% MCR	64	1.3	0.3 TO 0.5	95.3				
	3.	100% MCR	114.0	1.7	0.3 TO 0.5	108				
	4.	VWO	118	1.7	0.3 TO 0.5	108.8				
	5.	LPH-1 OUT	149.5	1.4	0.3 TO 0.5	104.4				
	VALVE TYPE							<input checked="" type="checkbox"/> CAVITATION <input checked="" type="checkbox"/> FLASHING <input type="checkbox"/> HIGH DP		
	MAX SHUT OFF PRESS ( KG/CM2g)                      7 VALVE DESIGN : PRESS (KG/CM2g)   TEMP (DEG C)                      7/VACUUM   115 IBR FORM III-C <input type="checkbox"/> REQUIRED <input checked="" type="checkbox"/> NOT REQUIRED							..... ..... ..... .....		
TOTAL WEIGHT (VALVE + ACTUATOR + ACCESSORIES) Kg							.....			

<b>BHEL PEM</b>	<b>Technical specification for Control Valves with Accessories (Pneumatically Operated)</b>  <b>2 X 500MW NEYVELI NEW TPP (NNTPP) (TG-PKG)</b>		SPECIFICATION NO.: PE-TS-402-145-1104	
			VOLUME IIB	
			SECTION D	
			REV. NO. 00	DATE : 18.12.2014
			SHEET 89	OF 128
Tag No. : ...DRV-48...		Qty.: ...1 per Unit ...	Data Sheet No. PES-145-06-DS1-0	
<b>DATA SHEET – A &amp; B</b>				
DATA SHEET – A FOR CONTROL VALVE (WITH PNEUMATIC ACTUATOR) (TO BE FILLED BY PURCHASER)			DATA SHEET – B (TO BE FILLED UP BY BIDDER)	
GENERAL	PROJECT SERVICE	NNTPP-2x500 MW LIGNITE FIRED UNIT AT NEYVELI		.....
	LOCATION	DEAERATOR OVERFLOW TO LP DRAIN F/T		.....
GENERAL	DUTY	<input checked="" type="checkbox"/> INDOOR <input type="checkbox"/> OUTDOOR <input checked="" type="checkbox"/> ON/OFF <input type="checkbox"/> MODULATING		.....
	PIPE SIZE (inlet / outlet)	168.3 x 7.11             273 x 9.27		.....
	PIPE MATERIAL (inlet / outlet)	SA 106 GR B             SA 106 GR C		.....
				.....
BODY	MODEL NO.	BIDDER TO SPECIFY		.....
	TYPE OF BODY: GUIDING: NO. OF PORTS	<input checked="" type="checkbox"/> GLOBE <input type="checkbox"/> ANGLE     <input type="checkbox"/> TOP <input checked="" type="checkbox"/> CAGE   ONE		.....
	BODY SIZE: PORT SIZE: DESIGN CV	BIDDER TO SPECIFY		.....
	END CONNECTION & RATING (ANSI)	<input checked="" type="checkbox"/> BWE <input type="checkbox"/> SWE <input type="checkbox"/> FLANGED		.....
	BODY MATERIAL	<input type="checkbox"/> A216 WCB <input checked="" type="checkbox"/> A217 WC9 <input type="checkbox"/> SS <input type="checkbox"/> A217 CS <input type="checkbox"/> A351 CF8M		.....
	PACKING: MATERIAL SINGLE / DOUBLE	<input type="checkbox"/> PTFE <input checked="" type="checkbox"/> GRAFOIL <input checked="" type="checkbox"/> DOUBLE <input type="checkbox"/> SINGLE		.....
	BONNET TYPE	BIDDER TO SPECIFY		.....
	TRIM FORM	<input type="checkbox"/> LINEAR <input type="checkbox"/> EQ. PERCENTAGE		.....
	TRIM MATERIAL: SEAT   PLUG	<input checked="" type="checkbox"/> QUICK OPEN (ON/OFF)		.....
	: CAGE   GUIDE BUSH	440 C       440 C 440 C       440 C		.....
FLOW DIRECTION	BIDDER TO SPECIFY		.....	
OUTLET VELOCITY	<input checked="" type="checkbox"/> < 7 M/SEC (WATER)     <input type="checkbox"/> MAC NO. < 1/3(STM)		.....	
REQUIRED LEAKAGE CLASS	<input type="checkbox"/> II <input type="checkbox"/> III <input type="checkbox"/> IV <input checked="" type="checkbox"/> V <input type="checkbox"/> VI		.....	
NOISE LEVEL (dBA)	LESS THAN 85 dBA		.....	
VACUUM SERVICE	<input checked="" type="checkbox"/> YES <input type="checkbox"/> NO		.....	
ANTI CAVITATION TRIM	<input type="checkbox"/> YES <input checked="" type="checkbox"/> NO		.....	
PNEUMATIC ACTUATOR	MODEL NO. & SIZE	BIDDER TO SPECIFY		.....
	CLOSE AT : OPEN AT (KG/CM2g)	TO SUIT ACTUATOR (AIR TO CLOSE)		.....
	TRAVEL TIME FOR OPEN TO CLOSE, CLOSE TO OPEN	<10 SEC		.....
VALVE POSN. ON ELEC SIGNAL FAILURE	<input checked="" type="checkbox"/> TO OPEN <input type="checkbox"/> STAYPUT <input type="checkbox"/> TO CLOSE		.....	
VALVE POSN. ON SUPPLY AIR FAILURE	<input checked="" type="checkbox"/> STAYPUT		.....	
ACCESSORIES	POSITIONER (SMART)	<input type="checkbox"/> REQUIRED <input checked="" type="checkbox"/> NOT REQUIRED		.....
	AIR FILTER REGULATOR	<input checked="" type="checkbox"/> REQUIRED <input type="checkbox"/> NOT REQUIRED		.....
	AIR LOCK RELAY	<input checked="" type="checkbox"/> REQUIRED <input type="checkbox"/> NOT REQUIRED		.....
	POSITION LIMIT SWITCH	<input type="checkbox"/> REQUIRED <input checked="" type="checkbox"/> NOT REQUIRED		.....
	POSITION TRANSMITTER	<input checked="" type="checkbox"/> REQUIRED <input type="checkbox"/> NOT REQUIRED		.....
	SOLENOID VALVE	<input checked="" type="checkbox"/> REQUIRED <input type="checkbox"/> NOT REQUIRED		.....
	E/P CONVERTER	<input type="checkbox"/> REQUIRED <input checked="" type="checkbox"/> NOT REQUIRED		.....
	JUNCTION BOX	<input checked="" type="checkbox"/> REQUIRED <input type="checkbox"/> NOT REQUIRED		.....
	HAND WHEEL (SIDE MOUNTED)	<input checked="" type="checkbox"/> REQUIRED		.....
	LOCAL POSITION INDICATOR	<input checked="" type="checkbox"/> REQUIRED		.....
ELECTRO PNEUMATIC POSITIONER	<input type="checkbox"/> REQUIRED <input checked="" type="checkbox"/> NOT REQUIRED		.....	















<b>BHEL PEM</b>	<b>Technical specification for Control Valves with Accessories (Pneumatically Operated)</b>  <b>2 X 500MW NEYVELI NEW TPP (NNTPP) (TG-PKG)</b>		SPECIFICATION NO.: PE-TS-402-145-1104	
			VOLUME IIB	
			SECTION D	
			REV. NO. 00	DATE : 18.12.2014
		SHEET 97	OF 128	
Tag No.: DMCW-67		Qty.: ...1 per Unit ...		Data Sheet No. PES-145-06-DS1-0
<b>DATA SHEET – A &amp; B</b>				
DATA SHEET – A FOR CONTROL VALVE (WITH PNEUMATIC ACTUATOR) (TO BE FILLED BY PURCHASER)			DATA SHEET – B (TO BE FILLED UP BY BIDDER)	
GENERAL	PROJECT	NNTPP-2x500 MW LIGNITE FIRED UNIT AT NEYVELI		.....
	SERVICE	DMCW SYSTEM		.....
GENERAL	LOCATION	<input checked="" type="checkbox"/> INDOOR <input type="checkbox"/> OUTDOOR		.....
	DUTY	<input type="checkbox"/> ON/OFF <input checked="" type="checkbox"/> MODULATING		.....
GENERAL	PIPE SIZE (inlet / outlet)	250 NB (273.0 X 6.35)   250 NB (273.0 X 6.35)		.....
	PIPE MATERIAL (inlet / outlet)	CARBON STEEL AS PER IS 2062/ SAME		.....
BODY	MODEL NO.	BIDDER TO SPECIFY		.....
	TYPE OF BODY: GUIDING: NO. OF PORTS	<input checked="" type="checkbox"/> GLOBE <input type="checkbox"/> ANGLE   <input type="checkbox"/> TOP <input checked="" type="checkbox"/> CAGE   ONE		.....
	BODY SIZE: PORT SIZE: DESIGN CV	BIDDER TO SPECIFY		.....
	END CONNECTION & RATING (ANSI)	<input checked="" type="checkbox"/> BWE <input type="checkbox"/> SWE <input type="checkbox"/> FLANGED		.....
	BODY MATERIAL	<input checked="" type="checkbox"/> A216 WCB <input type="checkbox"/> A217 WC6 <input type="checkbox"/> SS <input type="checkbox"/> A217 CS <input type="checkbox"/> A351 CF8M		.....
	PACKING: MATERIAL SINGLE / DOUBLE	<input type="checkbox"/> PTFE <input checked="" type="checkbox"/> GRAFOIL <input checked="" type="checkbox"/> DOUBLE <input type="checkbox"/> SINGLE		.....
	BONNET TYPE	BIDDER TO SPECIFY		.....
	TRIM FORM	<input type="checkbox"/> LINEAR <input checked="" type="checkbox"/> EQ. PERCENTAGE		.....
	TRIM MATERIAL: SEAT   PLUG	<input type="checkbox"/> QUICK OPEN (ON/OFF)		.....
	: CAGE   GUIDE BUSH	SS 316 STELLITED   SS 316 STELLITED 17-4 PH SS   SS 316 STELLITED		.....
BODY	FLOW DIRECTION	BIDDER TO SPECIFY		.....
	OUTLET VELOCITY	<input checked="" type="checkbox"/> < 7 M/SEC (WATER)   <input type="checkbox"/> MAC NO < 1/3 (STM)		.....
	REQUIRED LEAKAGE CLASS	<input type="checkbox"/> II <input type="checkbox"/> III <input checked="" type="checkbox"/> IV <input type="checkbox"/> V <input type="checkbox"/> VI		.....
	NOISE LEVEL (dBA)	LESS THAN 85 dBA		.....
	VACUUM SERVICE	<input type="checkbox"/> YES <input checked="" type="checkbox"/> NO		.....
	ANTI CAVITATION TRIM	<input type="checkbox"/> YES <input checked="" type="checkbox"/> NO		.....
				.....
PNEUMATIC ACTUATOR	MODEL NO. & SIZE	BIDDER TO SPECIFY		.....
	CLOSE AT : OPEN AT (KG/CM2g)	TO SUIT ACTUATOR (AIR TO OPEN)		.....
	TRAVEL TIME FOR	<10 SEC		.....
	OPEN TO CLOSE, CLOSE TO OPEN			.....
PNEUMATIC ACTUATOR	VALVE POSN. ON ELEC SIGNAL FAILURE	<input type="checkbox"/> TO OPEN <input type="checkbox"/> STAYPUT <input checked="" type="checkbox"/> TO CLOSE		.....
	VALVE POSN. ON SUPPLY AIR FAILURE	<input checked="" type="checkbox"/> STAYPUT		.....
ACCESSORIES	POSITIONER	<input checked="" type="checkbox"/> REQUIRED <input type="checkbox"/> NOT REQUIRED		.....
	AIR FILTER REGULATOR	<input checked="" type="checkbox"/> REQUIRED <input type="checkbox"/> NOT REQUIRED		.....
	AIR LOCK RELAY	<input checked="" type="checkbox"/> REQUIRED <input type="checkbox"/> NOT REQUIRED		.....
	POSITION LIMIT SWITCH	<input type="checkbox"/> REQUIRED <input checked="" type="checkbox"/> NOT REQUIRED		.....
	POSITION TRANSMITTER	PART OF POSITIONER		.....
	SOLENOID VALVE	<input type="checkbox"/> REQUIRED <input checked="" type="checkbox"/> NOT REQUIRED		.....
	E/P CONVERTER	PART OF POSITIONER		.....
	JUNCTION BOX	<input checked="" type="checkbox"/> REQUIRED <input type="checkbox"/> NOT REQUIRED		.....
	HAND WHEEL (SIDE MOUNTED)	<input checked="" type="checkbox"/> REQUIRED		.....
	LOCAL POSITION INDICATOR	<input checked="" type="checkbox"/> REQUIRED		.....
ELECTRO PNEUMATIC POSITIONER	<input checked="" type="checkbox"/> REQUIRED <input type="checkbox"/> NOT REQUIRED		.....	

<b>BHEL PEM</b>	<b>Technical specification for Control Valves with Accessories (Pneumatically Operated)  2 X 500MW NEYVELI NEW TPP (NNTPP) (TG-PKG)</b>					SPECIFICATION NO.: PE-TS-402-145-I104			
						VOLUME IIB			
						SECTION D			
						REV. NO. 00		DATE : 18.12.2014	
					SHEET 98 OF 128				
Tag No.: DMCW-67			Qty.: ...1 per Unit ...			Data Sheet No. PES-145-06-DS1-0			
<b>DATA SHEET – A &amp; B</b>									
DATA SHEET – A FOR CONTROL VALVE (WITH PNEUMATIC ACTUATOR) (TO BE FILLED BY PURCHASER)							DATA SHEET – B (TO BE FILLED UP BY BIDDER)		
PERFORMANCE OF VALVE	LINEARITY HYSTERESIS SENSITIVITY ACCURACY (OVERALL)			$\pm 1\%$ $\pm 1\%$ $\pm 0.5\%$ $\pm 1\%$		..... ..... .....			
SERVICE CONDITION	SL. No. +	LOAD	FLOW (T/HR)	INLET PR. KG/CM2(A)	OUTLET PR. KG/CM2(A)	TEMP DEG (C)	CALC ULATED CV	% VLV LIFT	VLV O/L VELOCITY
	1	100 %	330	6.5	3.0	38			
	2	75 %	247.5	6.5	3.0	38			
	3	50 %	165	6.5	3.0	38			
	4	25 %	82.5	6.5	3.0	38			
	VALVE TYPE						<input type="checkbox"/> CAVITATION <input type="checkbox"/> FLASHING <input type="checkbox"/> HIGH DP		
MAX SHUT OFF PRESS ( KG/CM2g) 10					.....				
BODY DESIGN : PRESS (KG/CM2g)   TEMP (DEG C) 10   60					..... .....				
IBR FORM III-C <input type="checkbox"/> REQUIRED <input checked="" type="checkbox"/> NOT REQUIRED					.....				
TOTAL WEIGHT (VALVE + ACTUATOR + ACCESSORIES) Kg							.....		

	<p>Technical specification for <b>Control Valves with Accessories</b> (Pneumatically Operated) <b>2 X 500MW NEYVELI NEW TPP (NNTPP)</b> (TG-PKG)</p>	SPECIFICATION NO. <b>PE-TS-402-145-1104</b>	
		VOLUME <b>II-B</b>	
		SECTION <b>D</b>	
		REV. NO. 00	DATE: 18.12.14
		SHEET 99	OF 128

## SECTION – D

# DATA SHEETS – ACCESSORIES FOR CONTROL VALVES

	<b>Technical specification for Control Valves with Accessories (Pneumatically Operated) 2 X 500MW NEYVELI NEW TPP (NNTPP) (TG-PKG)</b>	SPECIFICATION NO. PE-TS-402-145-1104	
		VOLUME IIB	
		SECTION D	
		REV. NO. 00	DATE: 18.12.14
		SHEET 100	OF 128

Tag No..... Quantity..... Data Sheet No. PES-145-06-DS1-0

**DATA SHEET – A & B for ACCESSORIES**

**DATA SHEET – A FOR CONTROL VALVE (WITH PNEUMATIC ACTUATOR)  
(TO BE FILLED BY PURCHASER)**

**DATA SHEET – B  
(TO BE FILLED-UP BY BIDDER)**

<b>POSITIONER (SMART)</b>	MFR. & MODEL NUMBER		BIDDER TO SPECIFY		
	BYPASS	GAUGES	ENCL. CLASS	<input type="checkbox"/> YES <input checked="" type="checkbox"/> NO	<input type="checkbox"/> THREE <input checked="" type="checkbox"/> TWO
	INPUT SIGNAL (ELECTRICAL)		4-20 mA DC, HART COMPATIBLE		
	OUTPUT SIGNAL (PNEUMATIC)(Kg / Cm <sup>2</sup> )		TO SUIT ACTUATOR		
<b>AIR FILTER REGULATOR (WITH AUTO DRAIN)</b>	MFR. & MODEL NUMBER		BIDDER TO SPECIFY		
	AIR SUPPLY PRESS (Kg / Cm <sup>2</sup> g)		<input checked="" type="checkbox"/> 5.0 - 8.0		
	FILTER SIZE		5 MICRONS		
	OUTPUT PRESS (Kg / Cm <sup>2</sup> g)		TO SUIT SMART POSITIONER		
<b>AIR LOCK</b>	MFR. & MODEL NUMBER		BIDDER TO SPECIFY		
	SET PRESS (Kg / Cm <sup>2</sup> )		BIDDER TO SPECIFY		
	SUPPLY PRESS (Kg / Cm <sup>2</sup> )		<input checked="" type="checkbox"/> 5.0 - 8.0		
	RESET TYPE		AUTO		
<b>LIMIT SWITCH (NOT APPLICABLE)</b>	MFR. & MODEL NUMBER		BIDDER TO SPECIFY		
	OPEN posn	INT posn	CLOSE posn	<input checked="" type="checkbox"/> 1 NO.	<input type="checkbox"/> --- <input checked="" type="checkbox"/> 1 NO.
	CONTACT TYPE		SPDT 2 NO + 2 NC		
	RATING (AC / DC)		5A 240V AC AND 0.2A 220V DC		
<b>POSITION TRANSMITTER</b>	MFR. & MODEL NUMBER		IN BUILT IN SMART POSITIONER EXCEPT FOR ON/OFF SERVICES		
	TYPE		<input checked="" type="checkbox"/> Electronic (2-Wire Type), Non-Contact Type <input type="checkbox"/> OTHER		
	SUPPLY		<input checked="" type="checkbox"/> 24V DC <input type="checkbox"/> 220V DC <input type="checkbox"/> 110V AC <input type="checkbox"/> 240V AC		
	OUTPUT RATING		<input checked="" type="checkbox"/> 4-20mA <input type="checkbox"/> 0-100 ohms		
	ACCURACY		± 1% FS		
<b>SOLENOID VALVE</b>	MFR. & MODEL NUMBER		BIDDER TO SPECIFY		
	RATING		<input checked="" type="checkbox"/> 24V DC <input type="checkbox"/> 220V DC <input type="checkbox"/> 240V AC <input type="checkbox"/>		
	OPERATION	QUANTITY	<input type="checkbox"/> Stayput <input checked="" type="checkbox"/> Interlock	AS PER DATASHEET & HOOK UP	
	COIL INSULATION CLASS		CLASS - H		
<b>HANDWHEEL</b>	ENCLOSURE CLASS		<input checked="" type="checkbox"/> IP 65		
	ORIENTATION		<input type="checkbox"/> TOP MOUNTED <input checked="" type="checkbox"/> SIDE MOUNTED		
	NO. OF WAYS		<input type="checkbox"/> 24-WAYS <input checked="" type="checkbox"/> 36-Ways <input type="checkbox"/> AS REQUIRED		
	SIZE		AS REQUIRED		
<b>JUNCTION BOX</b>	CABLE GLANDS (Size / Quantity)		AS REQUIRED (Double Compression Type).		
	ENCLOSURE CLASS		<input checked="" type="checkbox"/> IP 65		
	MFR. & MODEL NUMBER		IN BUILT IN SMART POSITIONER		
	INPUT SIGNAL	POWER SUPPLY			
SPLIT RANGE					
<b>SS Tubing &amp; Fittings / per CV</b>	ENCLOSURE CLASS				
	This is in addition to SS Tubing and fittings which are integral part of CV		12 Meters of 1/4" SS Tubing, with 1 set of SS Fittings for each CV for connection to IA Header on one end and accessories on another end of CV.		
					COMPANY SEAL
					NAME
					SIGNATURE
					DATE



Technical specification for  
**Control Valves with Accessories**  
(Pneumatically Operated)  
**2 X 500 MW NEYVELI NEW TPP (NNTPP)**  
(TG-PKG)

SPEC NO.: **PE-TS-402-145-I 104**

VOLUME II B

SECTION D

REV. NO. 00

DATE : 18.12.14

SHEET 101 OF 128

## SECTION-D

## DATA SHEETS -C

	<b>Technical specification for Control Valves with Accessories</b> (Pneumatically Operated) <b>2 X 500 MW NEYVELI NEW TPP (NNTPP)</b> (TG-PKG)	SPECIFICATION NO <b>PE-TS-402-145-I104</b>	
		VOLUME <b>II-B</b>	
		SECTION <b>D</b>	
		REV. NO. 00	DATE: 18.12.14
		SHEET 102	OF 128

	NAME
	SIGNATURE
	DATE

Tag No..... Quantity.....

Data Sheet No. PES-145-06-DS2-0

## DATA SHEET C

**DATA SHEET – C FOR CONTROL VALVE (WITH PNEUMATIC ACTUATOR)**  
**(TO BE FILLED BY THE BIDDER AFTER THE AWARD OF CONTRACT)**

<b>GENERAL</b>	PROJECT	
	SERVICE	
	LOCATION	
	DUTY	
	PIPE SIZE (inlet / outlet)	
	PIPE MATERIAL (inlet / outlet)	
<b>BODY</b>	MODEL NUMBER	
	TYPE OF BODY : GUIDING : NO. OF PORTS	
	BODY SIZE : PORT SIZE : DESIGN CV	
	END CONNECTION & RATING (ANSI)	
	BODY MATERIAL	
	PACKING MATERIAL SINGLE / DOUBLE	
	BONNET TYPE / MATERIAL	
	TRIM FORM	
	TRIM MATERIAL : SEAT   PLUG	
	TRIM MATERIAL : CAGE   GUIDE	
	FLOW	
	OUTLET VELOCITY	
	REQUIRED LEAKAGE CLASS	
	NOISE LEVEL (dBA) (Spec. 3.1.14)	
	VACUUM SERVICE	
ANTI CAVITATION TRIM		
<b>PNEUMATIC ACTUATOR</b>	MODEL NO. & SIZE	
	CLOSE AT : OPEN AT (Kg / Cm <sup>2</sup> g)	
	TRAVEL TIME FOR OPEN TO CLOSE, CLOSE TO OPEN	
	VLV POSN. ON SIGNAL ELEC FAILURE	
	VALVE POSN. ON SUPPLY AIR FAILURE	
<b>ACCESSORIES</b>	POSITIONER	
	AIR FILTER REGULATOR	
	AIR LOCK RELAY	
	POSITION LIMIT SWITCH	
	POSITION TRANSMITTER	
	SOLENOID VALVE	
	E / P CONVERTER	
	JUNCTION BOX	
	HAND WHEEL (SIDE MOUNTED)	
	LOCAL POSITION INDICATOR	
	ELECTRO PNEUMATIC POSITIONER	
PRESSURE GAUGES		

	<b>Technical specification for Control Valves with Accessories</b> (Pneumatically Operated)  <b>2 X 500 MW NEYVELI NEW TPP (NNTPP)</b> (TG-PKG)	SPECIFICATION NO <b>PE-TS-402-145-I104</b>	
		VOLUME <b>II-B</b>	
		SECTION <b>D</b>	
		REV. NO. 00	DATE: 18.12.14
		SHEET 103	OF 128

Tag No..... Quantity.....				Data Sheet No. PES-145-06-DS2-0					
<b>DATA SHEET C</b>									
<b>DATA SHEET – C FOR CONTROL VALVE (WITH PNEUMATIC ACTUATOR)</b> (TO BE FILLED BY THE BIDDER AFTER THE AWARD OF CONTRACT)									
<b>PERFORMANCE OF VALVE</b>	LINEARITY								
	HYSTERSIS								
	SENSITIVITY								
	ACCURACY								
<b>SERVICE CONDITION*</b>	<b>SL.+ NO.</b>	<b>LOAD</b>	<b>FLOW (T/HR)</b>	<b>INLET PR. (KG/CM<sup>2</sup> (A))</b>	<b>OUTLET PR. (KG/CM<sup>2</sup> (A))</b>	<b>TEMP DEG. C</b>	<b>CALCULATED CV</b>	<b>% VALVE LIFT</b>	<b>VALVE O/L VELOCITY</b>
VALVE TYPE									
* MAX SHUT OFF PRESS ((KG/CM <sup>2</sup> g)									
* BODY DESIGN : PRESS ((KG/CM <sup>2</sup> g)   TEMP (DEG. C)									
* IBR FORM III-C									
TOTAL WEIGHT (VALVE + ACTUATOR + ACCESSORIES) KG.									



Technical specification for  
**Control Valves with Accessories**  
(Pneumatically Operated)  
**2 X 500 MW NEYVELI NEW TPP (NNTPP)**  
(TG-PKG)

SPEC NO.: PE-TS-402-145-I 104

VOLUME	II B	
SECTION	D	
REV. NO.	00	DATE : 18.12.14
SHEET	104	OF 128

## SECTION-D

## QUALITY PLAN



## QUALITY PLAN FOR CONTROL VALVE (PNEUMATIC)

QUALITY PLAN NO.: <b>PE-QP-402-145-I 104</b>	
VOLUME	
SECTION	
REV. NO. 01	DATE: 21.08.2014
SHEET 2	OF 8

Sl. No.	Component / operation	Characteristics Checked	* Category	Type/Method of Check	Extent of Check	Reference documents	Acceptance Norms	Format of Records	Agency \$			Remarks
									P	W	V	
<b>1.0 MATERIAL</b>												
1.1	Body & Bonnet casting / forgings, plug, valve stem, seat ring/cage.	1. Physical, Chemical properties	MA	Physical, Chemical tests	One/Heat(HT Batch)	Approved drg. / data sheet / BHEL specn.	Approved drg. / data sheet / BHEL specn.	Test Certificate	3	---	2,1	
		2. Heat Treatment	MA	Review of H.T. Chart	Each H.T.	Approved drg. / data sheet / BHEL specn.	Approved drg. / data sheet / BHEL specn.	Test Certificate	3/2	2	1	IBR Certification (if applicable) to be verified by BHEL
		3. Internal quality of castings	MA	RT for Body & UT for Bonnet(NDT)	100%	ASME B 16.34	ASME B 16.34	Test Report / FILM	3/2	2	1	Only for rating ANSI 900 and above.  Applicable for Body and Bonnet only. For Lower rating only if called for in specification.
		4. Surface Quality	MA	1. Visual	100%	MSS-SP-55	MSS-SP-55	Test Certificate	3/2	---	2,1	
2. MT/PT	100%			ASME B 16.34	ASME B 16.34	Test Certificate	3	2	1	After Machining on machined surface only		

LEGEND: \* CR - Critical characteristics  
MA - Major characteristics  
MI - Minor characteristics

RT- Radiographic Test  
UT - Ultrasonic Test

PT - Dye penetrant Test  
MT- Magnetic Test

\$ P - Agency Performing the Test.  
W - Agency Witnessing the Test.  
V - Agency Verifying the Test.

1 - BHEL  
2 - Vendor  
3 - Sub-vendor  
4 - NLC/LII





## QUALITY PLAN FOR CONTROL VALVE (PNEUMATIC)

QUALITY PLAN NO.: <b>PE-QP-402-145-I 104</b>	
VOLUME	
SECTION	
REV. NO. 01	DATE: 21.08.2014
SHEET 3	OF 8

Sl. No.	Component / operation	Characteristics Checked	* Category	Type/Method of Check	Extent of Check	Reference documents	Acceptance Norms	Format of Records	Agency \$			Remarks
									P	W	V	
		5. Pressure test for shell	MA	Hyd. Test	100%	ISA-S-75.19/ ASME B 16.34	ISA-S-75.19/ ASME B 16.34	Test Certificate	2	2	1	For Body & Bonnet after machining
1.2	Diaphragm	1. Surface Quality	MA	Visual	100%	Mfr. standard	Mfr. standard	Test Certificate	3/2	---	2,1	
		2. Hardness	MA	Measurement	100%	Mfr. standard	Mfr. standard	Test Certificate	3/2	---	2,1	
		3. Endurance / Life cycle	MA	Cyclic test 10,000 cycles	One / Type	10,000 cycles/ Mfr. standard.	No damage	Test Certificate	3/2		2,1	
1.3	Spring	1. Composition	MA	Chemical- Analysis	One sample/ Heat	Material spec. / Mfr. standard	Material spec. / Mfr. standard	Test Certificate	3	---	2,1	
		2. Mech. Properties	MA	Mech. Test	One sample/ Heat	Material spec. / Mfr. standard	Material spec. / Mfr. standard	Test Certificate	3	---	2,1	
		3. Performance	MA	1. Stiffness ratio	100%	Material spec. / Mfr. standard	Material spec. / Mfr. standard	Test Certificate	3	---	2,1	
				2. Scragging	100%	Material spec. / Mfr. standard	Material spec. / Mfr. standard	Test Certificate	3	---	2,1	
				3. Cyclic test (Endurance)	One / type	10,000 cycles	Material spec. / Mfr. standard	Test Certificate	3	---	2,1	
4. Dimension (Measurement)	One sample/ Lot			Mfr. standard	Appd Drg	Record	3	---	2,1			

LEGEND: \* CR - Critical characteristics  
MA - Major characteristics  
MI - Minor characteristics

RT- Radiographic Test  
UT - Ultrasonic Test

PT - Dye penetrant Test  
MT- Magnetic Test

\$ P - Agency Performing the Test.  
W - Agency Witnessing the Test.  
V - Agency Verifying the Test.

1 - BHEL  
2 - Vendor  
3 - Sub-vendor  
4 - NLC/LII





## QUALITY PLAN FOR CONTROL VALVE (PNEUMATIC)

QUALITY PLAN NO.: <b>PE-QP-402-145-I 104</b>	
VOLUME	
SECTION	
REV. NO. 01	DATE: 21.08.2014
SHEET 4	OF 8

Sl. No.	Component / operation	Characteristics Checked	* Category	Type/Method of Check	Extent of Check	Reference documents	Acceptance Norms	Format of Records	Agency \$			Remarks
									P	W	V	
1.4	Electrical items [Limit switches, Solenoids, Position Transmitter(if provided externally)]	1. Routine Test	MA	HV, IR, Continuity function	100%	Rele. Standards	Rele. Standards	Test Certificate	3	---	2,1	In case TC is not available, Actual test shall be conducted
		2. Degree of protection	MA	IP/NEMA Tests	One sample / type	Approved Data sheet	Approved Data sheet	Test Certificate	3	---	2,1	
1.5	Pressure Gauges	1. Performance	MA	Review of calibration certificates	100%	Mfr. Standard	Mfr. Standard	Calibration Certificate	3	---	2,1	
		2. Marking	MA	Visual	100%	Mfr. standard	Mfr. standard	Records	3	---	2,1	
<b>2.0</b>	<b>IN PROCESS INSPECTION</b>											
2.1	After machining, i, Body ii Bonnet iii Plug iv Valve Stem v seat ring/cage	1. Surface flaws	MA	Visual & MT/PT	100% (on accessible surfaces)	ASME B 16.34	ASME B 16.34	Test Records	2	---	1	Butt weld ends shall be included.
		2. Dimensional checks	MA	Measurement	100%	Mfr. Standard	Mfr. Standard	Records	2	---	1	
		3. Hard facing (wherever applicable)	MA	Hardness Measurement	One sample/Lot	Mfr. Standard	Mfr. Standard	Records	2	---	1	
2.2	Lapping	Machining surface contact	MA	Blue Matching	One sample/lot	-----	Proper Physical Contact	---	2	---	---	
<b>3.0</b>	<b>TESTS ON COMPLETED VALVE</b>											

LEGEND: \* CR - Critical characteristics  
 MA - Major characteristics  
 MI - Minor characteristics

RT- Radiographic Test  
 UT - Ultrasonic Test

PT - Dye penetrant Test  
 MT- Magnetic Test

\$ P - Agency Performing the Test.  
 W - Agency Witnessing the Test.  
 V - Agency Verifying the Test.

1 - BHEL  
 2 - Vendor  
 3 - Sub-vendor  
 4 - NLC/LII





## QUALITY PLAN FOR CONTROL VALVE (PNEUMATIC)

QUALITY PLAN NO.: **PE-QP-402-145-I 104**

VOLUME

SECTION

REV. NO. 01 DATE: 21.08.2014

SHEET 5 OF 8

Sl. No.	Component / operation	Characteristics Checked	* Category	Type/Method of Check	Extent of Check	Reference documents	Acceptance Norms	Format of Records	Agency \$			Remarks
									P	W	V	
3.1	Actuator Chamber	Leakage & Strength	MA	Pneumatic test	100%	Mfr. Standard	No Leakage	Test Certificate	2	1	1	Refer Note-4
3.2	Body	Leakage and Pressure test (Body Mount Leakage)	MA	Hydro test	100%	ISA - S-75.19	No Leakage	Test Certificate	2	1	1	Refer Note-4
3.3	Seat leakage test for completed valve	Seat Leakage	MA	Pneumatic Test	100%	FCI-70.2	FCI-70.2	Test Certificate	2	1	1	Refer Note-4
4.0	<b>OPERATION TEST ON COMPLETED VALVE (Final inspection)</b>	1. Valve Travel	MA	Measurement	100%	Approved drg. / data sheet	Approved drg. / data sheet	Test Report	2	1,4	1,4	Refer Note-4
		2. Opening/Closing time	MA	Measurement	100%	Approved drg. / data sheet	Approved drg. / data sheet	Test Report	2	1,4	1,4	Refer Note-4
		3. Linearity/cam characteristic	MA	Measurement	100%	Approved drg. / data sheet	Approved drg. / data sheet	Test Report	2	1,4	1,4	Refer Note-4
		4. Repeatability	MA	Measurement	100%	Approved drg. / data sheet	Approved drg. / data sheet	Test Report	2	1,4	1,4	Refer Note-4
		5. Hysteresis	MA	Measurement	100%	Approved drg. / data sheet	Approved drg. / data sheet	Test Report	2	1,4	1,4	Refer Note-4
		6. Sensitivity	MA	Measurement	100%	Approved drg. / data sheet	Approved drg. / data sheet	Test Report	2	1,4	1,4	Refer Note-4
		7. Accuracy (Overall)	MA	Measurement	100%	Approved drg. / data sheet	Approved drg. / data sheet	Test Report	2	1,4	1,4	Refer Note-4
		8. Control Valve characteristics / CV Test	MA	◆ Measurement (Press. vs. discharge and discharge vs. opening 0-100% in steps of 10%)	One per type	As per specs/ Approved drg. / data sheet	As per specs/ Approved drg. / data sheet	Test Certificate	2	--	1,4	◆ Size = Body & port size Or Body size & CV for non std port. Refer Note 1.

LEGEND: \* CR - Critical characteristics  
MA - Major characteristics  
MI - Minor characteristics

RT- Radiographic Test  
UT - Ultrasonic Test  
PT - Dye penetrant Test  
MT- Magnetic Test

\$ P - Agency Performing the Test.  
W - Agency Witnessing the Test.  
V - Agency Verifying the Test.

1 - BHCL  
2 - Vendor  
3 - Sub-vendor  
4 - NLC/LII





PEM :: C&I

## QUALITY PLAN FOR CONTROL VALVE (PNEUMATIC)

QUALITY PLAN NO.: **PE-QP-402-145-I 104**

VOLUME

SECTION

REV. NO. 01 DATE: 21.08.2014

SHEET 6 OF 8

Sl. No.	Component / operation	Characteristics Checked	* Category	Type/Method of Check	Extent of Check	Reference documents	Acceptance Norms	Format of Records	Agency \$			Remarks
									P	W	V	
		9. Operation of limit switch & solenoids and other accessories	MA	Function	100%	Approved drg. / data sheet	As per specs/ Approved drg. / data sheet	Test Report	2	1,4	1,4	On assembled valve Refer Note-4
		10. Overall dimensions	MI	Visual and dimensional	100%	Approved drg. / data sheet	As per specs/ Approved drg. / data sheet	Records	2	1,4	1,4	Refer Note-4
		11. Pre defined valve position in case of air failure	MA	Visual	100%	As per spec & Appd drg	As per spec & Appd drg	Test Certificate	2	1,4	1,4	
		12. Cleanliness, painting, stamping (for direction of flow), Tag No.	MA	Visual and dimensional	100%	Approved drg. / data sheet	As per specs/ Approved drg. / data sheet	Test Certificate	2	1,4	1,4	
<b>5.0</b>	<b>AUXILIARY ITEMS (Performance test of auxiliary items shall be performed on the completely assembled valve)</b>											
5.1	Positioner	Overall leakage after assembly including Nozzles leakage	MA	Leak Test (in the steady state input signal)	100 %	Mfr. Standard	No leakage	Test Certificate	3/2	---	1	Overall leakage including tubing
5.2	Air filter regulator	1. Normal air consumption	MA	Measurement	Each type	Mfr. Standard	No leakage	Test Certificate	3/2	---	1	
		2. Overall leakage	MA	Visual (soap solution)	100 %	Mfr. Standard	No leakage	Test Certificate	3/2	---	1	
5.3	Air lock relay	Performance Test	MA	Leakage test	100%	Mfr. Standard	No leakage	Test Certificate	3/2	---	1	
5.4	Electronic position transmitter(not applicable if provided integral to smart positioner)	1. Accuracy	MA	Operation	100%	Approved data sheet /	Approved data sheet /	Test Certificate	2	1	1	

LEGEND: \* CR - Critical characteristics  
MA - Major characteristics  
MI - Minor characteristics

RT- Radiographic Test  
UT - Ultrasonic Test  
PT - Dye penetrant Test  
MT- Magnetic Test

\$ P - Agency Performing the Test.  
W - Agency Witnessing the Test.  
V - Agency Verifying the Test.

1 - BHEL  
2 - Vendor  
3 - Sub-vendor  
4 - NLC/LII





## QUALITY PLAN FOR CONTROL VALVE (PNEUMATIC)

QUALITY PLAN NO.: <b>PE-QP-402-145-I 104</b>	
VOLUME	
SECTION	
REV. NO. 01	DATE: 21.08.2014
SHEET 7	OF 8

Sl. No.	Component / operation	Characteristics Checked	* Category	Type/Method of Check	Extent of Check	Reference documents	Acceptance Norms	Format of Records	Agency \$			Remarks
									P	W	V	
5.5	Current to Pneumatic converter(not applicable for smart positioner)	1. Physical Verification Make/Model	MA	Visual	100%	Approved drg. / data sheet	Approved drg. / data sheet	Test Certificate	2	---	2,1	
		2. Degree of Protection	MA	IP/NEMA test	Each type	Relevant Standard	Relevant Standard	Test Certificate	3	---	2,1	
		3. Linearity	CR	Measurement	100%	Approved drg. / data sheet	Approved drg. / data sheet	Inspection Report	2	---	1	
		4. Hysterisis	CR	Measurement	100%	Approved drg. / data sheet.	Approved drg. / data sheet	Inspection Report	2	---	1	
5.6	Smart Positioner (As Applicable)	1. Physical Verification Make/Model	MA	Visual	100%	Approved drg. / data sheet	Approved drg. / data sheet	Test Certificate	2	---	2,1	
		2. Degree of Protection	MA	IP/NEMA test	Each type	Relevant Standard	Relevant Standard	Test Certificate	3	---	2,1	
		3. Linearity	CR	Measurement	100%	Approved drg. / data sheet	Approved drg. / data sheet	Inspection Report	2	---	1	
		4. Hysterisis	CR	Measurement	100%	Approved drg. / data sheet	Approved drg. / data sheet	Inspection Report	2	---	1	
		5. Calibration with Hand Held Communicator	MA	Measurement	Each type	Approved data sheet / Mfr. Standard	Approved data sheet / Mfr. Standard	Test Certificate	2	1	1	
6.0	<b>PAINTING</b>	Soundness of Painting	MA	Visual and Measurement	100%	BHEL specn. / Mfr. Standard	BHEL specn. / Mfr. Standard	Inspection Report	2	---	---	Refer Note-2
7.0	<b>PACKING</b>	Soundness of Packing against transit damage	MA	Visual	100%	Mfr. Standard	Mfr. Standard	Inspection Report	2	---	---	Refer Note-3

LEGEND: \* CR - Critical characteristics  
 MA - Major characteristics  
 MI - Minor characteristics

RT- Radiographic Test  
 UT - Ultrasonic Test

PT - Dye penetrant Test  
 MT- Magnetic Test

\$ P - Agency Performing the Test.  
 W - Agency Witnessing the Test.  
 V - Agency Verifying the Test.

1 - BHEL  
 2 - Vendor  
 3 - Sub-vendor  
 4 - NLC/LII







Technical specification for  
**Control Valves with Accessories**  
(Pneumatically Operated)

**2 X 500MW NEYVELI NEW TPP (NNTPP)**  
**(TG-PKG)**

SPEC NO.: **PE-TS-402-145-I 104**

VOLUME II B

SECTION D

REV. NO. 00

DATE : 18.12.2014

SHEET 114

OF 128

## SECTION-D

## BILL OF QUANTITY



Technical specification for  
**Control Valves with Accessories**  
(Pneumatically Operated)

**2 X 500 MW NEYVELI NEW TPP (NNTPP)  
(TG-PKG)**

SPECIFICATION NO. **PE-TS-402-145-I104**

VOLUME **II-B**

SECTION **D**

REV. NO. 00

DATE: 18.12.2014

SHEET 115

OF 128

## BILL OF QUANTITY

**[A] CONTROL VALVES COMPLETE WITH SMART POSITIONER  
AND ALL ACCESSORIES MOUNTED, TUBED AND TERMINATED ON JB**

Sl. No.	TAG NO.	SERVICE/ ITEM DESCRIPTION	QTY/UNIT	QTY FOR 2 UNITS
1	ASV-8	D/A PEGGING FROM AUX. STEAM HEADER	1	2
2	CRHV-6	D/A PEGGING FROM AUX. CRH LINE	1	2
3	CDV-22	MAIN CONDENSATE CONTROL	1	2
4	CDV-25	MAIN CONDENSATE CONTROL	1	2
5	CDV-10	CEP-A MIN. FLOW RECIRCULATION	1	2
6	CDV-12	CEP-B MIN. FLOW RECIRCULATION	1	2
7	CDV-14	CEP-C MIN. FLOW RECIRCULATION	1	2
8	CDV-39	CEP MIN. FLOW RECIRCULATION	1	2
9	CDV-43	EXCESS RETURN TO CST	1	2
10	CDV-67	CONDENSATE SPRAY TO SD FLASH TANK	1	2
11	CDV-72	CONDENSATE FOR VALVE GLAND SEALING	1	2
12	DRV-2	HPH-6A NORMAL DRAIN TO HPH-5A	1	2
13	DRV-8	HPH-6B NORMAL DRAIN TO HPH-5B	1	2
14	DRV-5	HPH-6A ALT. DRAIN TO HP DRAIN F/T	1	2
15	DRV-11	HPH-6B ALT. DRAIN TO HP DRAIN F/T	1	2
16	DRV-15	HPH-5A NORMAL DRAIN TO DEAERATOR	1	2
17	DRV-22	HPH-5B NORMAL DRAIN TO DEAERATOR	1	2
18	DRV-18	HPH-5A ALT. DRAIN TO HPD F/T	1	2
19	DRV-25	HPH-5B ALT. DRAIN TO HPD F/T	1	2
20	DRV-28	LPH-3 NORMAL DRAIN TO LPH-2	1	2
21	DRV-31	LPH-3 ALT. DRAIN TO LP DRAIN F/T	1	2
22	DRV-34	LPH-2 NORMAL DRAIN TO LPH-1	1	2
23	DRV-37	LPH-2 ALT. DRAIN TO LP DRAIN F/T	1	2
24	DRV-48	DEAERATOR OVERFLOW TO LP DRAIN F/T	1	2
25	DMV-2	CT PUMP RECIRCULATION	1	1
26	DMV-38	DM NORMAL MU TO HOTWELL	1	2
27	DMV-63	DM EMERGENCY MU TO HOTWELL	1	2
28	DMCW-67	DMCW SYSTEM	1	2
<b>[B]</b>	<b>¼" SS TUBING (To be supplied Loose)</b>		350 metres	700 metres
<b>[C]</b>	<b>FITTINGS: (To be supplied Loose)</b>	(i) SS FITTING for Connection to Air Filter Regulator	1 Lot	2 Lots
		(ii) SS FITTING for Connection to Air Lock Relay	1 Lot	2 Lots
		(iii) SS FITTING for Connection to IA Header isolation valve	1 Lot	2 Lots
		(iv) SS EQUAL TEE	1 Lot	2 Lots
<b>[D]</b>	<b>SOFTWARE &amp; ACCESSORIES</b>			
1	VALVE DIAGNOSTIC & CONFIGURATION SOFTWARE		1 No.	2 Nos.



Technical specification for  
**Control Valves with Accessories**  
(Pneumatically Operated)  
**2 X 500 MW NEYVELI NEW TPP (NNTPP)**  
(TG-PKG)

SPEC NO.: **PE-TS-402-145-I 104**

VOLUME II B

SECTION D

REV. NO. 00

DATE : 18.12.2014

SHEET 116

OF 128

## SECTION-D

## SPARES

	<b>Technical specification for Control Valves with Accessories</b> (Pneumatically Operated) <b>2 X 500 MW NEYVELI NEW TPP (NNTPP)</b> <b>(TG-PKG)</b>	SPECIFICATION NO. PE-TS-402-145-1104	
		VOLUME II-B	
		SECTION D	
		REV. NO. 00	DATE: 18.12.2014
		SHEET 117	OF 128

#### LIST OF COMMISSIONING SPARES

SI. No.	ITEM DESCRIPTION	QUANTITY
1.	Gaskets	One (1) set with each control valve Tag
2.	Gland Packings	One (1) set with each control valve Tag

#### LIST OF MANDATORY SPARES

SI. No.	ITEM DESCRIPTION	QUANTITY FOR 2 UNITS
1.	Complete set of control valve each size and type with actuator	5 %
2.	Valve trim (including cage, plug, stem, seat rings, guide bushings etc.) of each size and type	2 Sets
3.	Gaskets (including Body seal gaskets) of each type and size	5 Sets
4.	Gland Packing each size and type	5 Sets
5.	Actuator Diaphragm	5% of each type & size
6.	Seal box O-rings	5% of each type & size
7.	Colour O-rings	5% of each type & size
8.	Solenoid Valves (Complete Instrument)	5% of each model & type
9.	Valve Positioner (Complete Instrument)	5% of each model & type
10.	Position transmitters (Complete Instrument)	5% of each model & type
11.	Air Set/Regulator with gauge	5%
12.	Air lock relay	5%
13.	Air Booster/Accumulator	5%

#### NOTES:

Wherever % is indicated, the quantity shall be calculated for **% of supply for total quantity of 2 units**, unless otherwise specified. The quantity to be reckoned for % indicated shall be rounded off to the next higher whole number. For example if the % of total quantity arrived is 0.2, the quantity to be supplied shall be 1 and if the % of total quantity is 5.1, the quantity to be supplied shall be 6.

	<p>Technical specification for <b>Control Valves with Accessories</b> (Pneumatically Operated) <b>2 X 500MW NEYVELI NEW TPP (NNTPP)</b> (TG-PKG)</p>	SPECIFICATION NO. <b>PE-TS-402-145-1104</b>	
		VOLUME <b>II-B</b>	
		SECTION <b>D</b>	
		REV. NO. 00	DATE: 18.12.2014
		SHEET 118	OF 128

## SECTION – D

## SUB VENDORS LIST

	<b>Technical specification for Control Valves with Accessories</b> (Pneumatically Operated)  <b>2 X 500MW NEYVELI NEW TPP (NNTPP)</b> (TG-PKG)	SPECIFICATION NO. <b>PE-TS-402-145-1104</b>	
		VOLUME II-B	
		SECTION D	
		REV. NO. 00	DATE: 18.12.2014
		SHEET 119	OF 128

### SUB VENDOR LIST

- |                         |  |
|-------------------------|--|
| 1. Air Filter regulator | Placka/ Shavo Norgan/ ABB/Bells Control/Schrader/Veljan              |
| 2. Solenoid             | ASCO/Avcon/ Rotex/ Schrader/ Herion Norgren/ Schovill<br>Duncan Ltd. |
| 3. Smart Positioner     | Metso/ Emerson/ Seimens/ ABB/ Flow Serve/ Foxboro/ Yamatake          |

	<b>Technical specification for Control Valves with Accessories</b> (Pneumatically Operated) <b>2 X 500MW NEYVELI NEW TPP (NNTPP)</b> <b>(TG-PKG)</b>	SPECIFICATION NO. PE-TS-402-145-1104	
		VOLUME II-B	
		SECTION D	
		REV. NO. 00	DATE: 18.12.2014
		SHEET 120	OF 128

**SCHEDULE OF SUBMISSION OF DRAWINGS / DOCUMENTS, EQUIPMENT MANUFACTURE INSPECTION AND DESPATCH**

1.	<b><u>ZERO DATE</u></b>	<b><u>DATE of LOI / FOI / TOI</u></b>
2.	Submission of Data Sheets / documents / catalogues / Valve sizing calculations / Noise calculations for approval.	2 Weeks from the Zero date.
3.	Technical finalisation, freezing of inputs of manufacture by way of vetting of documents and technical discussions and resubmissions of documents (if required)	6 Weeks from the Zero date.
4.	Inspection of Equipment as per Approved (Category-I) drawings / documents.	24 Weeks from the Zero date.
5.	Release of MDCC by BHEL	26 Weeks from the Zero date.
6.	Dispatch (Packaging & Dispatch)	26 Weeks from the Zero date.
7.	Final documents submission as per Contract	28 Weeks from the Zero date.

**NOTE:** Delays due to non-fulfillment of the requirements of approved Quality Plan and approved Data sheets, Drawings, Catalogues and Sizing Calculations observed during inspection shall be to the Vendor's account.

Delays due to INCOMPLETE (Partly) submission of Data sheets, Drawings, Catalogues and Sizing Calculations also be considered as "**DOCUMENTS NOT SUBMITTED**"

**(Signature and Stamp of the Bidder)**

**2 X 500MW NEYVELI NEW TPP (NNTPP)  
TG PACKAGE**

**TECHNICAL SPECIFICATION  
FOR  
CONTROL VALVES WITH ACCESSORIES  
(Pneumatically Operated)**

**VOLUME III**

**SPECIFICATION No: PE-TS-402-145-I 104**



**BHARAT HEAVY ELECTRICALS LIMITED  
POWER SECTOR  
PROJECT ENGINEERING MANAGEMENT DIVISION  
NOIDA, INDIA**

	<p style="text-align: center;">Technical specification for  <b>Control Valves with Accessories</b>  (Pneumatically Operated)    <b>2 X 500MW NEYVELI NEW TPP (NNTPP)</b>  <b>(TG-PKG)</b></p>	SPEC NO.: PE-TS-402-145-I 104	
		VOLUME <b>III</b>	
		SECTION	
		REV. NO. 00	DATE: 18.12.2014
		SHEET 122 OF 128	

## CONTENTS

### VOL-III

Sl. No.	DESCRIPTION	No. of sheets
1.	SCHEDULE OF DRAWINGS, DATA SHEETS, DOCUMENTS, AND CATALOGUES SUBMITTED WITH THE BID	1
2.	SCHEDULE OF PRICES	2
3.	SCHEDULE OF UNIT PRICES	1
4.	Cv TEST CHARGES	1
5.	INSPECTION SCHEDULE	1
6.	DEVIATION SCHEDULE	1



Technical specification for  
**Control Valves with Accessories**  
(Pneumatically Operated)  
2 X 500MW NEYVELI NEW TPP (NNTPP)  
(TG-PKG)

SPECIFICATION NO. : PE-TS-402-145-II04	
VOLUME III	
SECTION	
REV. NO. 00	DATE: 18.12.2014
SHEET 123	OF 128

**SCHEDULE OF DRAWINGS, DATASHEETS, DOCUMENTS, CATALOGUES  
SUBMITTED WITH THE BID**

<b>PARTICULARS OF THE BIDDER / AUTHORISED REPRESENTATIVE</b>				
NAME	DESIGNATION	SIGNATURE	DATE	COMPANY SEAL



Technical specification for  
**Control Valves with Accessories**  
(Pneumatically Operated)  
**2 X 500MW NEYVELI NEW TPP (NNTPP)**  
(TG-PKG)

SPECIFICATION NO. : PE-TS-402-145-II04

VOLUME III

SECTION

REV. NO. 00

DATE: 18.12.2014

SHEET 124 OF 128

----NOT USED----



**Technical specification for  
Control Valves with Accessories  
(Pneumatically Operated)  
2 X 500MW NEYVELI NEW TPP (NNTPP)  
(TG-PKG)**

SPECIFICATION NO. : PE-TS-402-145-II04

VOLUME III

SECTION

REV. NO. 00

DATE: 18.12.2014

SHEET 125 OF 128

## SCHEDULE OF PRICES

**[A] CONTROL VALVES COMPLETE WITH SMART POSITIONER  
AND ALL ACCESSORIES MOUNTED, TUBED AND TERMINATED ON JB**

Sl. No.	TAG NO.	SERVICE/ ITEM DESCRIPTION	PRICE PER UNIT	TOTAL PRICE FOR 2 UNITS
1	ASV-8	D/A PEGGING FROM AUX. STEAM HEADER		
2	CRHV-6	D/A PEGGING FROM AUX. CRH LINE		
3	CDV-22	MAIN CONDENSATE CONTROL		
4	CDV-25	MAIN CONDENSATE CONTROL		
5	CDV-10	CEP-A MIN. FLOW RECIRCULATION		
6	CDV-12	CEP-B MIN. FLOW RECIRCULATION		
7	CDV-14	CEP-C MIN. FLOW RECIRCULATION		
8	CDV-39	CEP MIN. FLOW RECIRCULATION		
9	CDV-43	EXCESS RETURN TO CST		
10	CDV-67	CONDENSATE SPRAY TO SD FLASH TANK		
11	CDV-72	CONDENSATE FOR VALVE GLAND SEALING		
12	DRV-2	HPH-6A NORMAL DRAIN TO HPH-5A		
13	DRV-8	HPH-6B NORMAL DRAIN TO HPH-5B		
14	DRV-5	HPH-6A ALT. DRAIN TO HP DRAIN F/T		
15	DRV-11	HPH-6B ALT. DRAIN TO HP DRAIN F/T		
16	DRV-15	HPH-5A NORMAL DRAIN TO DEAERATOR		
17	DRV-22	HPH-5B NORMAL DRAIN TO DEAERATOR		
18	DRV-18	HPH-5A ALT. DRAIN TO HPD F/T		
19	DRV-25	HPH-5B ALT. DRAIN TO HPD F/T		
20	DRV-28	LPH-3 NORMAL DRAIN TO LPH-2		
21	DRV-31	LPH-3 ALT. DRAIN TO LP DRAIN F/T		
22	DRV-34	LPH-2 NORMAL DRAIN TO LPH-1		
23	DRV-37	LPH-2 ALT. DRAIN TO LP DRAIN F/T		
24	DRV-48	DEAERATOR OVERFLOW TO LP DRAIN F/T		
25	DMV-2	CT PUMP RECIRCULATION		
26	DMV-38	DM NORMAL MU TO HOTWELL		
27	DMV-63	DM EMERGENCY MU TO HOTWELL		
28	DMCW-67	DMCW SYSTEM		
[B]	350 meters OF SS TUBING (Per Unit) FOR CONNECTION BETWEEN IA HEADER ON ONE END AND ACCESSORIES ON THE OTHER END OF CV			
[C]	(i) 1 LOT OF SS FITTINGS FOR CONNECTION TO AIR FILTER REGULATOR (AS PER HOOK-UP DIAGRAM)			
	(ii) 1 LOT OF SS FITTINGS FOR CONNECTION TO AIR LOCK RELAY (AS PER HOOK-UP DIAGRAM)			
	(iii) 1 LOT OF SS FITTINGS FOR CONNECTION TO IA HEADER ISOLATION VALVE (AS PER HOOK-UP DIAGRAM)			
	(iv) 1 LOT OF SS EQUAL TEE (AS PER HOOK-UP DIAGRAM)			
[D]	START-UP/COMMISSIONING SPARES(SEPARATE SHEET WITH BREAK UP TO BE ATTACHED)			
	(i) 1 SET OF BODY AND BONNET GASKETS FOR EACH CV			
	(ii) 1 SET OF GLAND PACKINGS FOR EACH CV			
[E]	MANDATORY SPARES AS PER LIST ENCLOSED IN SECTION D (SEPARATE SHEET WITH BREAK UP TO BE ATTACHED)			
[F]	Cv TEST CHARGES FOR EACH TYPE OF CONTROL VALVE			
[G]	SOFTWARE FOR CONFIGURATION , DIAGNOSTIC, CALIBRATION & TESTING (FOR ALL TAGS)			



Technical specification for  
**Control Valves with Accessories**  
(Pneumatically Operated)  
2 X 500MW NEYVELI NEW TPP (NNTPP)  
(TG-PKG)

SPECIFICATION NO. : PE-TS-402-145-II04  
VOLUME III  
SECTION  
REV. NO. 00      DATE: 18.12.2014  
SHEET 126 OF 128

## SCHEDULE OF UNIT PRICES

### CONTROL VALVE ACCESSORIES

S. No.	ITEMS	UNIT PRICE
1. \$	POSITIONER EACH MODEL AND TYPE	
2.	AIR FILTER REGULATOR	
3.	AIR LOCK RELAY	
4. \$	POSITION LIMIT SWITCH OF EACH MODEL AND TYPE	
5.	ELECTRONIC POSITION TRANSMITTER OF EACH MODEL AND TYPE	
6.	SOLENOID VALVE	
7.	VOLUME BOOSTER (PNEUMATIC RELAY)	
8. \$	PRESSURE GAUGES OF EACH TYPE	
9.	JUNCTION BOX (36 WAYS)	
10.	HANDWHEEL	
11. \$	ACTUATOR OF EACH TYPE	
12.	BRASS FITTING FOR CONNECTION TO AIR FILTER REGULATOR	
13.	BRASS FITTING FOR CONNECTION TO AIR LOCK RELAY	
14.	BRASS FITTINGS FOR CONNECTING TO AIR HEADER	
15.	BRASS EQUAL TEE	
16.	COPPER TUBING PER METRE	
17. \$	VALVE STEM WITH PLUG & SEAT RING EACH SIZE & TYPE	
18. \$	GASKET OF EACH SIZE AND TYPE	
19. \$	BODY SEAL GASKETS OF EACH SIZE AND TYPE	
20. \$	CAGE OF EACH SIZE AND TYPE	
21. \$	GLAND PACKING EACH SIZE AND TYPE	
22. \$	VALVE TRIM OF EACH SIZE AND TYPE	
23. \$	DIAPHRAM OF EACH SIZE AND TYPE	
24. \$	SEAL BOX "O" RING OF EACH TYPE AND SIZE	
25. \$	COLOR "O" RING OF EACH TYPE AND SIZE	
26.	POSITION TRANSMITTER	

#### NOTE

\$: Separate list to be attached for each size and type of these control valve accessories.

#### PARTICULARS OF THE BIDDER / AUTHORISED REPRESENTATIVE

NAME	DESIGNATION	SIGNATURE	DATE	COMPANY SEAL



Technical specification for  
**Control Valves with Accessories**  
(Pneumatically Operated)  
**2 X 500MW NEYVELI NEW TPP (NNTPP)**  
(TG-PKG)

SPECIFICATION NO. : PE-TS-402-145-I104

VOLUME III

SECTION

REV. NO. 00

DATE: 18.12.2014

SHEET 127 OF 128

## INSPECTION SCHEDULE

(PLACE & ADDRESS OF TESTING/ INSPECTION AND ITS SCHEDULE DATE & DURATION IN NUMBER OF DAYS ITEM/COMPONENTWISE TO BE LISTED)

### PARTICULARS OF THE BIDDER / AUTHORISED REPRESENTATIVE

NAME	DESIGNATION	SIGNATURE	DATE	COMPANY SEAL



Technical specification for  
**Control Valves with Accessories**  
(Pneumatically Operated)  
2 X 500MW NEYVELI NEW TPP (NNTPP)  
(TG-PKG)

SPECIFICATION NO. : PE-TS-402-145-I104

VOLUME III

SECTION

REV. NO. 00

DATE: 18.12.2014

SHEET 128 OF 128

## DEVIATION SCHEDULE

PARTICULARS OF THE BIDDER / AUTHORISED REPRESENTATIVE				
NAME	DESIGNATION	SIGNATURE	DATE	COMPANY SEAL