

**TAMIL NADU GENERATION AND  
DISTRIBUTION CORPORATION LTD.**

**2X660 MW SEZ ENNORE STPP**

---

**VOLUME – II B & III**

---

**TECHNICAL SPECIFICATION  
FOR  
DOUBLE GIRDER EOT CRANES  
(Up to 50T Capacity)**

**SPECIFICATION NO.: PE-TS-412-501-A101(Rev 0)**



**BHARAT HEAVY ELECTRICALS LIMITED  
POWER SECTOR  
PROJECT ENGINEERING MANAGEMENT  
NOIDA, INDIA**



**2X660 MW SEZ ENNORE STPP**  
Double girder EOT cranes For  
BFP & Sea water Intake pump house  
(up to 50T capacity )

SPECIFICATION NO. PE-TS-412-501-A101

REV 00

June,2015

SHEET 1 OF 1

**INDEX**  
**VOLUME – IIB**

SECTIONS	TITLE	Nos. of Pages	
SECTION-A	INTENT OF SPECIFICATION	3	
SECTION-B	PROJECT INFORMATION	12	
<b>SECTION-C</b>			
SECTION-C1	GENERAL TECHNICAL REQUIREMENTS	37	
SECTION-C2	SPECIFIC REQUIREMENT-SCOPE OF WORK	9	
SECTION-C3	TECHNICAL SPECIFICATION		
C3 - A	Technical requirement (Data sheet A)	13	
C3 - B	Quality Assurance plan	9	
C3 - C	Painting specification	7	
SECTION-C4	Technical specification -(Electrical portion)	51	
SECTION-C5	<b><u>ANNEXURES</u></b>		
i)	List of Makes of Sub-vendor items	ANNEXURE-I	2
ii)	List of Mandatory spares	ANNEXURE-II	2
iii)	Format for operation maintenance & manual	ANNEXURE-III	3
iv)	Shop test procedure for gear boxes & Load/ Overload testing of cranes at manufatcurer's works	ANNEXURE-IV	7
v)	Drawings/documents for submission along with Master Drawing list with schedule of submission.	ANNEXURE-V	2
vi)	Site storage and preservation	ANNEXURE-VI	15
SECTION-D	STANDARD TECHNICAL SPECIFICATION	24	

**VOLUME-III**

SECTIONS	TITLE	Page
1	List of documents to be submitted with bid	1
2	Compliance cum confirmation certificate	2
3	Pre Bid Clarification Schedule	1
4	Deviation sheet ( cost of withdrawl)	1
5	Electrical Load list	1
<b>REFERENCE /INPUT DRAWINGS</b>		
1.	Crane Clearance Diagram for BFP Cranes( Drg no PE-DG-412-501-A002)	1
2.	Crane Clearance Diagram for Sea water intake pump house crane ( Drg no PE-DG-412-501-A101)	1

**TITLE****Technical Specification**

For Double girder EOT Cranes for BFP  
Sea water Intake pump house  
(Up to 50T Cap.)

**INTENT OF SPECIFICATION**

SPECIFICATION NO. PE-TS-412-501-A101

VOLUME: II B

Section A

REV 00

June 2015

Page 1 of 3

**VOLUME - IIB****SECTION – A**

**TITLE****Technical Specification**

For Double girder EOT Cranes for BFP  
Sea water Intake pump house  
(Up to 50T Cap.)

**INTENT OF SPECIFICATION**

SPECIFICATION NO. PE-TS-412-501-A101

VOLUME: II B

Section A

REV 00

June 2015

Page 1 of 3

**VOLUME - IIB****SECTION – A**

**TITLE**

**Technical Specification**  
For Double girder EOT Cranes for BFP  
Sea water Intake pump house  
(Up to 50T Cap.)

**INTENT OF SPECIFICATION**

SPECIFICATION NO. PE-TS-412-501-A101

VOLUME: II B

Section A

REV 00

June 2015

Page 2 of 3

**SCOPE OF ENQUIRY/INTENT OF SPECIFICATION**

- 1.1 This specification includes, but not limited to design, engineering, material selection, manufacturing and assembly, inspection, testing at manufacturer's works, packing, forwarding and transportation to site, unloading, storage & handling at site handling, preservation, security / safety at site, erection, commissioning and final load test at site and handing over to BHEL's customer for BFP cranes ( 2 nos) & Sea water Intake pump/Raw water intake pump house crane ( 1 No.).
- 1.2 The contractor shall be responsible for providing all material, equipment & services, which are required to fulfill the intent of ensuring operability, maintainability, reliability and complete safety of the complete work covered under this specification, irrespective of whether it has been specifically listed herein or not. **Omission of specific reference to any component / accessory necessary for proper performance of the equipment shall not relieve the contractor of the responsibility of providing such facilities to complete the supply, erection & commissioning and load testing of the cranes and its accessories.**
- 1.3 It is not the intent to specify herein all the details of design and manufacture. However, the equipment shall conform in all respects to high standards of design, engineering and workmanship and shall be capable of performing the required duties in a manner acceptable to purchaser who will interpret the meaning of drawings and specifications and shall be entitled to reject any work or material which in his judgement is not in full accordance herewith.
- 1.4 The extent of supply under the contract includes all items shown in the drawings, notwithstanding the fact that such items may have been omitted from the specification or schedules. Similarly, the extent of supply also includes all items mentioned in the specification and /or schedules, notwithstanding the fact that such items may have been omitted in the drawing.
- 1.5 The general term and conditions, instructions to tenderer and other attachment referred to elsewhere are made part of the tender specification. The equipment materials and works covered by this specification is subject to compliance to all attachments referred to in the specification. The bidder shall be responsible for and governed by all requirements stipulated herein.
- 1.6 While all efforts have been made to make the specification requirement complete & unambiguous, it shall be bidders' responsibility to ask for missing information, ensure completeness of specification, to bring out any contradictory / conflicting requirement in different sections of the specification and within a section itself to the notice of BHEL and to seek any clarification on specification requirement in the format enclosed under Vol-III of the specification **within 10 days of receipt of tender documents.** In absence of any such clarifications, in case of any contradictory requirement, the more stringent requirement as per interpretation of Purchaser/Customer shall prevail and shall be complied by the bidder without any commercial implication on account of the same. Further in case of any missing information in the specification not brought out by the prospective bidders as part of pre-bid clarification, the same shall be furnished by Purchaser/ Customer as and when brought to their notice either by the bidder or by purchaser/ customer themselves. However, such requirements shall be binding on the successful bidder without any commercial & delivery implication.
- 1.7 The bidder's offer shall not carry any sections like clarification, interpretations and /or assumptions.
- 1.8 Deviations, if any, should be very clearly brought out clause by clause in the enclosed deviation schedule along with cost of withdrawal; otherwise, it will be presumed that the vendor's offer is strictly in line with NIT specification. If no cost of withdrawal is given against the deviation, it will be presumed that deviation can be withdrawn without any cost to BHEL/its customer.
- 1.9 In the event of any conflict between the requirements of two clauses of this specification documents or requirements of different codes and standards specified, Section - C shall prevail over section – D, however more stringent requirement as per the interpretation of the owner shall apply.
- 1.10 In case all above requirements are not complied with, the offer may be considered as incomplete and would become liable for rejection.

**TITLE****Technical Specification**

For Double girder EOT Cranes for BFP  
Sea water Intake pump house  
(Up to 50T Cap.)

**INTENT OF SPECIFICATION**

SPECIFICATION NO. PE-TS-412-501-A101

VOLUME: II B

Section A

REV 00

June 2015

Page 3 of 3

1.11 Unless specified otherwise, all through the specification, the word contractor shall have same meaning as successful bidder /vendor and Customer/ Purchaser/Employer will mean BHEL and /or customer including their consultant as interpreted by BHEL in the relevant context. For details refer the relevant clause in GCC.

## CHAPTER 1

### PROJECT SYNOPSIS

#### 1.0 GENERAL BACKGROUND AND SALIENT FEATURES

##### 1.1 Introduction

Tamilnadu Generation and Distribution Corporation owns the proposed green-field 1320 MW (2 units of 660 MW each) Coal Based Thermal Power Station at Katupalli. This is an expansion of North Chennai Thermal Power Station (NCTPS) and located on some portion of the ashdyke of NCTPS.

##### 1.2 Location

The proposed site for main power plant is located near Ennore port (approx 5 kms).

The nearest Railway station is at Athipattu Pudunagar (approx 5 kms)

All weather road from Pattamandri on the Thiruvottiyur-Ponneri district highway is the nearest road access.

The nearest airport is at Chennai at a distance of 60 km.

##### 1.3 Type of Plant

The proposed 2x660 MW Super-Critical Power Project consists of coal fired steam generator connected to a reheat type steam turbine generator along with all the required auxiliaries. Circulating cooling water system is envisaged for condenser cooling.

The description and salient technical data of the Steam Generator, Steam Turbine Generator, Auxiliary systems, Electrical, Control & Instrumentation, Civil etc. are explained elsewhere in the specification:

##### 1.4 PROJECT INFORMATION

Project Title : **2 x 660 M W E nnore S E Z C oal B ased  
Supercritical T hermal P ower Project at Ash  
Dyke of NCTPS**



2 x 660 MW Ennore SEZ Supercritical Thermal Power  
Project at Ash Dyke of NCTPS  
Spec. No. CE/C/P&E/EE/E/OT.No.03 /2013-14



Owner : **TAMIL NADU GENERATION AND DISTRIBUTION CORPORATION (TANGEDCO)**

### LOCATION

The site is located near Vayalur Village, Ennore

Latitude : 13<sup>0</sup>17' N to 13<sup>0</sup>18' N

Longitude : 80<sup>0</sup>18' E to 80<sup>0</sup>19' E

Distance from Chennai City : 35 km

Nearest Airport is at Chennai at a

Distance of : 60 km

Nearest Seaport is : Ennore

Nearest Railway Station is : Athipattu Pudunagar (approx 5 kms)

### Meteorological Condition

**Climate** : Tropical ,very dry and hot summer, dry and cold winter and good rain-fall in monsoon accompanied with strong wind.

Climatological data : Ambient temp. (°C)  
Annual Maximum Mean Temp 41.5(°C)  
Annual Minimum Mean Temp 24(°C)  
Design Ambient temperature 35(°C)

#### Relative Humidity

Maximum 100%  
Minimum 36%  
Design 75%

#### Annual Rainfall

Maximum 2540 mm  
Average 1600 mm  
Minimum 1175 mm

#### Prevailing Wind Direction

Nov to Jan – From NW & NE



2 x 660 MW Ennore SEZ Supercritical Thermal Power  
Project at Ash Dyke of NCTPS  
Spec. No. CE/C/P&E/EE/E/OT.No.03 /2013-14



Feb to Mar – From East & SE  
 Apr to May – From South & SE  
 June – From SW  
 July to Aug – From NW  
 Sept to Oct – From SE & SW  
 Wind Speed 11.8 kmph (avg)  
 50 kmph (max)  
 Seismic Zone III as per  
 IS:1893-2002

### 1.5 Access to Site

Site is well connected to all weather road from Pattamandri on the Thiruvottiyur – Ponneri district highway. Site is located adjacent to the Chennai – Howrah broad gauge line and thus well connected by rail also.

### 1.6 Plant Rating, Capacity, Availability, PLF

Each of the two units shall have a Turbine maximum continuous rating (TMCR) of 660 MW at generator terminals based on the following site conditions.

- Ambient air temperature
- Condenser cooling water inlet temperature of 33°C and 9°C temperature rise across the condenser.
- Generator power factor of 0.85.
- Fuel specification as given elsewhere.
- Design temperature for electrical equipment is 50°C.

The VVO capacity of the steam turbine shall not be less than 105% of TMCR flow at rated parameters. Boiler maximum Continuous Rating (BMCR) will be established to match the steam flow at VVO conditions, but BMCR flow shall not less than 108% of TMCR flow.

The capacity of the unit is selected so as to deliver the rated output even after ageing that will occur between overhauls, as a result of deposition of salts in turbine blades, wear and tear etc.

The plant load factor (PLF) being considered is 85%.

### 1.7 Power Evacuation

Power will be evacuated from the proposed thermal power station at 400 KV voltage level through 400 KV transmission lines . The power evacuation lines would be double circuit 400 KV lines which will act as Line in & Line out circuit.



2 x 660 MW Ennore SEZ Supercritical Thermal Power  
 Project at Ash Dyke of NCTPS  
 Spec. No. CE/C/P&E/EE/E/OT.No.03 /2013-14



## 1.8 Site Selection

The following factors which influence the project site selection have been found very favourable to establish and operate the project.

- a. Availability of fuel.
- b. Existing power plant
- c. Availability of adequate cooling water.
- d. Availability of adequate land for locating the power plant with approach roads.
- e. Suitability of land from topographical and geological aspects
- f. Proximity of National Highways, Ports & Transport of fuel & heavy equipment.
- g. Facility for interconnection with transmission and distribution system for evacuation of power.
- h. Environmental aspects.

Total land required for the project is 500 acres which is under the possession of TANGEDCO.

## 1.9 Fuel

### 1.9.1 Source of Fuel

Domestic coal requirement for the power plant will be sourced from Kalinga block of Talcher coal fields, Mahanadi and IB valley coal fields in the state of Orissa. Coal will be transported by sea. The port of dispatch and port of receipt for domestic coal would be Paradip port and Ennore port respectively. Imported coal shall be sourced from foreign countries through sea to Ennore port.

Coal can be transported from coal mines to Ennore port by sea and unloaded at proposed coal berth-III. Further the coal can be transported to the proposed power plant through pipe conveyor which shall have a system capacity of 2 x 2000TPH.

The steam generator shall be designed for the following conditions :

- **Best Coal** – 100% Imported Coal
- **Design Coal** – 70% Imported & 30% Domestic Coal
- **Worst Coal** – 50% Imported & 50% Domestic Coal

The analysis of fuel is given below :

### 1.9.2 Coal Analysis:

#### Coal Quality Parameters

SL.NO	DESCRIPTION	DOMESTIC COAL	IMPORTED COAL
1.	HIGHER HEATING	2800 (GCV as	6250 ( GCV Air



2 x 660 MW Ennore SEZ Supercritical Thermal Power  
Project at Ash Dyke of NCTPS  
Spec. No. CE/C/P&E/EE/E/OT.No.03 /2013-14



	VALUE -As Fired basis given Kcal/kg	received basis)	dried basis) 5642 (as received basis)
2.	TOTAL MOISTURE %	During rainy season 20% ( inherent + surface)	16.5%
3.	HGI Abrasive expected YGP Shale and sand stone content Feed coal size	45 to 55 Average 52 50 to 70 mg/kg 20% max. upto 50 mm.	51

**DOMESTIC COAL**

Sr. No.	Particulars	Units	Parameters
A.	<b>Proximate Analysis</b>		
1.	Moisture	%	16.00
2.	Volatile Matter	%	19.00
3.	Ash	%	45.00
4.	Fixed carbon	%	20.00
	Total	%	100
B.	<b>ULTIMATE ANALYSIS, % ( As received)</b>		
1.	Carbon	%	27.70
2.	Hydrogen	%	2.60
3.	Nitrogen	%	0.52
4.	Oxygen	%	7.26
5.	Sulphur	%	0.50
6.	Ash	%	45.00
7.	Moisture	%	16.00
8.	Carbonates	%	0.38
9.	Phosphorous	%	0.04
10.	Others	%	-
	Total	%	100.00
C.	<b>Ash fusion temperature</b>	deg C	
1.	Initial deformation, IT	deg C	1100
2.	Spherical, ST	deg C	1200
3.	Hemispherical, HT	deg C	1300
4.	Fluid, FT	deg C	-
D.	<b>Ash Analysis, %</b>		
1.	SiO <sub>2</sub>	%	59.54
2.	Al <sub>2</sub> O <sub>3</sub>	%	29.00
3.	Fe <sub>2</sub> O <sub>3</sub>	%	6.42
4.	CaO	%	1.50
5.	Na <sub>2</sub> O	%	0.08



2 x 660 MW Ennore SEZ Supercritical Thermal Power  
Project at Ash Dyke of NCTPS  
Spec. No. CE/C/P&E/EE/E/OT.No.03 /2013-14



Sr. No.	Particulars	Units	Parameters
6.	K <sub>2</sub> O	%	-
7.	TiO <sub>2</sub>	%	1.60
8.	SO <sub>3</sub>	%	0.25
9.	P <sub>2</sub> O <sub>5</sub>	%	0.51
10.	MgO	%	0.50
11.	Others	%	0.60
12.	Total		100.00
E	<b>Resistivity of fly ash</b>	Ohm - cm	1.73x 10 <sup>12</sup>

**IMPORTED COAL**

Sr. No.	Particulars	Units	Parameters
A.	<b>Proximate Analysis (As received)</b>		
1.	Moisture	%	16.50
2.	Volatile Matter	%	36.45
3.	Ash	%	6.62
4.	Fixed carbon	%	40.43
5.	Total	%	100.00
B.	<b>ULTIMATE ANALYSIS, % (As received)</b>		
1.	Carbon	%	60.12
2.	Hydrogen	%	4.38
3.	Nitrogen	%	1.48
4.	Oxygen	%	10.37
5.	Sulphur	%	0.53
6.	Ash	%	6.62
7.	Moisture	%	16.5
8.	Carbonates	%	-
9.	Phosphorous	%	-
10.	Others	%	-
	Total	%	100.00
C.	<b>Ash fusion temperature</b>	deg C	
1.	Initial deformation, IT	deg C	1230
2.	Spherical, ST	deg C	1270
3.	Hemispherical, HT	deg C	1320
4.	Fluid, FT	deg C	-
D.	<b>Ash Analysis, %</b>		
1.	SiO <sub>2</sub>	%	36.00
2.	Al <sub>2</sub> O <sub>3</sub>	%	13.90
3.	Fe <sub>2</sub> O <sub>3</sub>	%	14.80
4.	CaO	%	12.70
5.	Na <sub>2</sub> O	%	0.70
6.	K <sub>2</sub> O	%	1.70
7.	TiO <sub>2</sub>	%	0.80



2 x 660 MW Ennore SEZ Supercritical Thermal Power  
Project at Ash Dyke of NCTPS  
Spec. No. CE/C/P&E/EE/E/OT.No.03 /2013-14



Sr. No.	Particulars	Units	Parameters
8.	SO3	%	10.60
9.	P2O5	%	0.20
10.	MgO	%	8.60
11.	Others	%	-
12.	Total	%	100.00

The plant should be suitable to accept imported coal sourced from any country. The limiting parameters of imported coal are furnished below :

S. No.	Particulars	Unit	Parameter
1	Total Moisture (ARB)	%	Up to 23 (Max)
2	Ash (ADB)	%	Up to 20 (Max)
3	Gross Calorific Value (ADB)	Kcal / Kg	5800 - 6500
4	Sulphur (ADB)	%	Up to 1 (Max)
5	Fixed Carbon (ADB)	%	30-50
6	Volatile Matter (ADB)	%	25-45
7	HGI		45-60
8	IDT (Under Reducing Atmosphere)	Deg C	1100-1250
9	Size	mm	< 50

**Note:** ADB stands for “As dried Basis” and ARB for “As Received Basis”

### 1.9.3 Specification of LDO

Specific gravity @ 15° C	0.8348
Gross calorific value, Kcal/kg	10400
Pour point “°C” max.	12
Flash point “°C” min.	66
Sulphur % “T” max.	0.5
K. Viscosity in Centistokes @ 50° C max.	7.5
Ash by wt. %	0.01
Water & sediment Vol. Max. %	0.25

### 1.9.4 Specification of HFO

Flash point “°C” min.	66
K. Viscosity in Centistokes @ 50° C max.	370



2 x 660 MW Ennore SEZ Supercritical Thermal Power  
Project at Ash Dyke of NCTPS  
Spec. No. CE/C/P&E/EE/E/OT.No.03 /2013-14



Ash by wt. %	0.1
Water content by volume % max	1
Sediment by weight % max	0.25
Total Sulphur by weight % max	4.5
Gross calorific value, Kcal/kg	10800

### 1.9.5 Fuel Linkage

TANGEDCO has approached Ministry of Coal through Ministry of Power for the long term linkage of Coal from the coal sources of Talcher or Mahanadi in Orissa.

The coal requirement has been worked as under:-

Coal required at MCR per hr. (Blended) 872 tonnes

Per day 20928 tonnes.

Annual 6.5 MTPA for 85% PLF

### 1.9.6 Fuel Transportation

The coal shall be received at Ennore port. The coal will be transported by pipe conveyor from coal berth 3 in Ennore Port and then through 2 x 2000 TPH pipe conveyor to the bunker directly or to stockyard.

### 1.10 Source Of Water

#### 1.10.1 Source

The raw water intake shall be from the existing cooling water forebay of NCTPS PHASE-II.

#### 1.10.2 Chemical analysis of Sea Water:

As given in Annexure-1, Volume III, Chapter- 3.

#### 1.10.3 Requirement

The requirement of water for the plant will be for meeting the requirement of make up for the re-circulating cooling water system, dust suppression system in coal handling plants, ash disposal system and the RO/ D.M. water plant which will be supplying the power cycle make up requirements, etc. In addition the water requirements will be for drinking and service purposes. Water requirement is estimated as approx. 15523 m<sup>3</sup>/hr.



**1.11 Source of Equipment**

The proposed plant will be supplied, erected and commissioned on Single EPC basis.

**1.12 Power Evacuation Plan**

Power will be evacuated from the proposed thermal power station at 400 KV voltage level through 400 KV transmission lines . The power evacuation lines would be double circuit 400 KV lines.

**1.13 400 KV GIS Switchyard**

The 400 KV Switchyard is proposed to have one and a half bus arrangement and will comprise following bays/circuits :

- ◆ 2 – Generator transformer bays
- ◆ 1– Start up transformer bay
- ◆ 4 – Line Bays
- ◆ 2 – Bus VT's
- ◆ 2 – Bus Reactor Bays
- ◆ 2 – Spare bay (Equipped)
- ◆ 1 – Equipped bay for future GT
- ◆ 2 – Equipped bays for future lines

The switchyard will be complete with galvanized steel structures, lightning surge arrestors, OPGW Equipment, CTs, PTs of suitable VA burden and accuracy class as required for measurement protection and communication, insulators, bus-bars clamps & hard wares etc. The switchyard will be controlled by computerized control and data acquisition (SCADA) system.

**1.14 Average Yearly Generation**

The average yearly generation is calculated considering the following.

- The expected plant load factor is 85 %. With this PLF the average yearly generation will be around 11914 Million units.

**1.15 INFORMATION FOR ENVIRONMENTAL APPRAISAL****1.0 GENERAL INFORMATION ABOUT THE PROJECT**

- 1.1 Name / Title of the Project : 2 x 660 MW Ennore SEZ Coal Based Supercritical Thermal Power Project at Ash Dyke of NCTPS
- 1.2 Name of Owner : Tamilnadu Generation and Distribution Corporation (TANGEDCO)



2 x 660 MW Ennore SEZ Supercritical Thermal Power  
Project at Ash Dyke of NCTPS  
Spec. No. CE/C/P&E/EE/E/OT.No.03 /2013-14



- 1.3 Location of the Project : Near Vayalur Village, Ennore, Tamil Nadu
- 1.4 Site where proposed plant is to be located : Ash dyke of NCTPS
- 1.5 Capacity of the project under consideration : 2x 660MW
- 1.5.1 Govt. land / Private land / others : TANGEDCO land
- 1.5.2 Topographical feature, demographic profile & physiography : Site has differential levels and require filling to maintain the desired grade level of +10.00 meter above MSL
- 1.5.3 Nature of soil : Clayey soil
- 1.5.4 Distance from the nearest town / city / major human settlements : Chennai -35 km
- 1.5.5 Population to be displaced : Nil
- 1.5.6 Distance from water source : Approx. 5 km (from Cooling Water Forebay of NCTPS Stage II)
- 1.5.7 Area of forest land, if involved : Nil
- 1.5.8 Distance of forest from the site : N.A
- 1.6 Is this an extension? : No  
If so indicate capacity of existing plant
- 1.7 What is the ultimate capacity envisaged : 2x660 MW
- 2.0 GENERAL ENVIRONMENTAL INFORMATION**
- 2.1 Area of the land proposed to be acquired : Refer Plot Plan Land already acquired
- i. Area required for plant : 500 Acres
- ii. Ash disposal : 100 % dry fly ash disposal and



2 x 660 MW Ennore SEZ Supercritical Thermal Power  
Project at Ash Dyke of NCTPS  
Spec. No. CE/C/P&E/EE/E/OT.No.03 /2013-14



- 100% wet bottom ash disposal is envisaged to existing ash pond.
- iii. Plant facilities : The area is adequate for locating all the required systems for 2x660 MW.
- 2.2 Area proposed to be built-up or developed : Power station will be built-up in the proposed site as indicated in the plot plan.
- 2.3 Specify site characteristics River basin/ estuarine / coastal / others : Site is close to Buckingham Canal
- 2.4 Is the site situated in the forest area? Give following details : No
- 2.4.1 Area : N.A
- 2.4.2 Type of forests : N.A
- 2.5 Is site situated near to the forests? Give the distance from the site. : N.A.
- 2.6 Give a description of the flora within 25 km of your plant site under the following heads :
- a. Crops :  
b. Forest :  
c. Grass land :  
d. Endangered species :  
e. Others (Specify) :
- } Refer details in the specification elsewhere.
- 2.6.2 Give details of the following features, if they exist, within a radius of 25 km of the proposed site? :
- i. Fisheries :  
ii. Sanctuary / natural park biosphere reserve :  
iii. Lakes / ponds / reservoir :  
iv. Stream / river : Buckingham canal is close to the site  
v. Estuary / sea : Bay of Bengal is 5 km from site



- vi. Hills / mountains :
  - vii. Historic / cultural /  
tourist /  
archaeological scenic  
sites / defence  
installations
- 2.7 Human settlement :
- 2.7.1 Total number of persons :  
proposed to be employed
- i. During construction : 2500  
  
450(0.75person/MW) TANGEDCO
  - ii. During operation : direct employees



2 x 660 MW Ennore SEZ Supercritical Thermal Power  
Project at Ash Dyke of NCTPS  
Spec. No. CE/C/P&E/EE/E/OT.No.03 /2013-14



**CHAPTER – 3****GENERAL TECHNICAL REQUIREMENTS****1.00.00 INTRODUCTION**

This part covers technical requirements, which will form an integral part of the Contract. The following provisions shall supplement all the detailed technical requirements brought out in the Technical Specifications and the Technical Data Sheets.

**2.00.00 BRAND NAME**

Whenever a material or article is specified or described by the name of a particular brand, manufacturer or vendor, the specific item mentioned shall be understood to be indicative of the function and quality desired, and not restrictive; other manufacturer's products may be considered provided sufficient information is furnished to enable the Owner to determine that the products proposed are equivalent to those named.

**3.00.00 BASE OFFER & ALTERNATE PROPOSALS**

The Bidder's proposal shall be based upon the use of equipment and material complying fully with the requirements specified herein. It is recognized that the Bidder may have standardized on the use of certain components, materials, processes or procedures different than those specified herein. Alternate proposals offering similar equipment based on the manufacturer's standard practice may also be considered, provided the base offer is in line with technical specifications and such proposals meet the specified design standards and performance requirement and are acceptable to the Owner. Sufficient amount of information for justifying such proposals shall be furnished to Owner along with the bid to enable the Owner to determine the acceptability of these proposals.

**4.00.00 COMPLETENESS OF FACILITIES**

4.01.00 Bidders may note that this is a contract inclusive of the scope as indicated elsewhere in the specification. Each of the plant shall be engineered and designed in accordance with the specification requirement. All engineering and associated services are required to ensure that a completely engineered plant is provided.

4.02.00 All equipment furnished by the Bidder shall be complete in every respect, with all mountings, fittings, fixtures and standard accessories normally provided with such equipment and/or those needed for erection, completion and safe operation & maintenance of the equipment and for the safety of the operating personnel, as required by applicable codes, though they may not have been specifically detailed in the respective specifications, unless included in the list of exclusions.



2 x 660 MW Ennore SEZ Supercritical Thermal Power  
Project at Ash Dyke of NCTPS  
Spec. No. CE/C/P&E/EE/E/OT.No.03 /2013-14



All similar standard components/ parts of similar standard equipment provided, shall be interchangeable with one another.

**5.00.00 CODES & STANDARDS**

5.01.00 In addition to the codes and standards specifically mentioned in the relevant technical specifications for the equipment / plant / system, all equipment parts, systems and works covered under this specification shall comply with all currently applicable statutory regulations and safety codes of the Republic of India as well as of the locality where they will be installed, including the following:

- (a.) Bureau of Indian Standards (BIS)
- (b.) Indian electricity act
- (c.) Indian electricity rules
- (d.) Indian Explosives Act
- (e.) Indian Factories Act and State Factories Act
- (f.) Indian Boiler Regulations (IBR)
- (g.) Regulations of the Central Pollution Control Board, India
- (h.) Regulations of the Ministry of Environment & Forest (MoEF), Government of India
- (i.) Pollution Control Regulations of Department of Environment, Government of India
- (j.) State Pollution Control Board.
- (k.) Rules for Electrical installation by Tariff Advisory Committee (TAC).
- (l.) Any other statutory codes / standards / regulations, as may be applicable.

5.02.00 Unless covered otherwise by Indian codes & standards and in case nothing to the contrary is specifically mentioned elsewhere in the specifications, the latest editions (as applicable as on date of bid opening), of the codes and standards given below shall also apply:

- (a.) Japanese Industrial Standards (JIS)
- (b.) American National Standards Institute (ANSI)
- (c.) American Society of Testing and Materials (ASTM)
- (d.) American Society of Mechanical Engineers (ASME)



2 x 660 MW Ennore SEZ Supercritical Thermal Power  
Project at Ash Dyke of NCTPS  
Spec. No. CE/C/P&E/EE/E/OT.No.03 /2013-14



- (e.) American Petroleum Institute (API)
  - (f.) Standards of the Hydraulic Institute, U.S.A.
  - (g.) International Organisation for Standardization (ISO)
  - (h.) Tubular Exchanger Manufacturer's Association (TEMA)
  - (i.) American Welding Society (AWS)
  - (j.) National Electrical Manufacturers Association (NEMA)
  - (k.) National Fire Protection Association (NFPA)
  - (l.) International Electro-Technical Commission (IEC)
  - (m.) Expansion Joint Manufacturers Association (EJMA)
  - (n.) Heat Exchange Institute (HEI)
- 5.03.00 Other International/ National standards such as DIN, VDI, BS, etc. shall also be accepted for only material codes and manufacturing standards, subject to the Owner's approval, for which the Bidder shall furnish, alongwith the offer, adequate information to justify that these standards are equivalent or superior to the standards mentioned above. In all such cases the Bidder shall furnish specifically the variations and deviations from the standards mentioned else where in the specification together with the complete word to word translation of the standard that is normally not published in English.
- 5.04.00 As regards highly standardized equipment such as Steam Turbine and Generator, National /International standards such as JIS, DIN, VDI, ISO, SEL, SEW, VDE, IEC & VGB shall also be considered as far as applicable for Design, Manufacturing and Testing of the respective equipment. In addition, these standards shall be referred for the design of machine foundations, wherever specifically mentioned in the specifications. However, for those of the above equipment not covered by these National / International standards, established and proven standards of manufacturers shall also be considered.
- 5.05.00 In the event of any conflict between the codes and standards referred to in the above clauses and the requirement of this specification, the requirement of Technical Specification shall govern.
- 5.06.00 Two (2) English language copies of all-national and international codes and/or standards used in the design of the plant, equipment, civil and structural works shall be provided by the Bidder to the Owner within two calendar months from the date of the Notification of Award.
- 5.07.00 In case of any change in codes, standards & regulations between the date of bid opening and the date when vendors proceed with fabrication, the Owner shall have the option to incorporate the changed requirements or to retain the original standard. It shall be the responsibility of the Bidder to bring to the notice of the Owner such changes and advise Owner of the resulting effect.
- 6.00.00 EQUIPMENT FUNCTIONAL GUARANTEE**



2 x 660 MW Ennore SEZ Supercritical Thermal Power  
Project at Ash Dyke of NCTPS  
Spec. No. CE/C/P&E/EE/E/OT.No.03 /2013-14



- 6.01.00 The Equipment and Auxiliaries shall be capable of continuous operation in frequency range of 47.5 to 51.5 Hz.
- 6.02.00 The functional guarantees of the equipment under the scope of the Contract is given elsewhere in the technical specification. These guarantees shall supplement the general functional guarantee provisions covered under General Conditions of Contract.
- 6.03.00 Liquidated damages for shortfall in meeting functional guarantee(s) during the performance and guarantee tests shall be assessed and recovered from the Bidder as specified elsewhere in this specification.

**7.00.00 DESIGN OF FACILITIES/ MAINTENANCE & AVAILABILITY CONSIDERATIONS**

**7.01.00 Design of Facilities**

All the design procedures, systems and components proposed shall have already been adequately developed and shall have demonstrated good reliability under similar conditions elsewhere.

The Bidder shall be responsible for the selection and design of appropriate equipment to provide the best co-ordinate performance of the entire system. The basic requirements are detailed out in various clauses of the Technical Specifications. The design of various components, assemblies and subassemblies shall be done so that it facilitates easy field assembly and dismantling. All the rotating components shall be so selected that the natural frequency of the complete unit is not critical or close to the operating range of the unit.

**7.02.00 Maintenance and Availability Considerations**

Equipment/facilities offered shall be designed for high availability, low maintenance and ease of maintenance. The Bidder shall specifically state the design features incorporated to achieve high degree of reliability/ availability and ease of maintenance. The Bidder shall also furnish details of availability records in the reference plants stated in his experience list.

Bidder shall state in his offer the various maintenance intervals, spare parts and man-hour requirement during such operation. The intervals for each type of maintenance namely inspection of the furnace, inspection of the entire hot gas path and the minor and major overhauls shall be specified in terms of fired hours, clearly defining the spare parts and man-hour requirement for each stage.



2 x 660 MW Ennore SEZ Supercritical Thermal Power  
Project at Ash Dyke of NCTPS  
Spec. No. CE/C/P&E/EE/E/OT.No.03 /2013-14



Lifting devices like lifting tackles, slings, etc. to be connected to hook of the hoist / crane shall be provided by the Bidder for lifting the equipment and accessories covered under the specification.

**8.00.00 DOCUMENTS, DATA AND DRAWINGS TO BE FURNISHED BY BIDDER**

8.01.00 Each of the plant and equipment shall be fully integrated, engineered and designed to perform in accordance with the technical specification. All engineering and technical services required ensuring a completely engineered plant shall be provided in respect of mechanical, electrical, control & instrumentation, civil & structural works as per the scope.

The Bidder shall furnish engineering data/drgs. in accordance with the schedule of information as specified in Technical Specification and data sheets.

8.02.00 The number of copies/prints/CD-ROMs/manuals to be furnished for various types of documents is given in Annexure-I attached

8.03.00 The documentation that shall be provided by the Bidder is indicated in various sections of specification.



2 x 660 MW Ennore SEZ Supercritical Thermal Power  
Project at Ash Dyke of NCTPS  
Spec. No. CE/C/P&E/EE/E/OT.No.03 /2013-14



**8.03.01 Instruction Manuals**

The Bidder shall submit to the Owner, draft Instruction Manuals for all the equipment covered under the Contract by the end of one year from the date of his acceptance of the Letter of Award. The Instruction manuals shall contain full details required for erection, commissioning, operation and maintenance of each equipment. The manual shall be specifically compiled for this project. After finalization and approval of the Owner the Instruction Manuals shall be submitted as indicated in Annexure-I. The Contract shall not be considered to be completed for purposes of taking over until the final Instructions manuals have been supplied to the Owner. The Instruction Manuals shall comprise of the following.

**Erection Manuals**

The erection manuals shall be submitted atleast three (3) months prior to the commencement of erection activities of particular equipment/system. The erection manual should contain the following as a minimum.

- a) Erection strategy.
- b) Sequence of erection.
- c) Erection instructions.
- d) Critical checks and permissible deviation/tolerances.
- e) List of tool, tackles, heavy equipment like cranes, dozers, etc.
- f) Bill of Materials
- g) Procedure for erection.
- h) General safety procedures to followed during erection/installation.
- i) Procedure for initial checking after erection.
- j) Procedure for testing and acceptance norms.
- k) Procedure / Check list for pre-commissioning activities.
- l) Procedure / Check list for commissioning of the system.



- m) Safety precautions to be followed in electrical supply distribution during erection

#### Operation & Maintenance Manuals

- i. The operating and maintenance instructions together with drawings (other than shop drawings) of the equipment, as completed, shall be in sufficient detail to enable the Owner to operate, maintain, dismantle, reassemble and adjust all parts of the equipment. They shall give a step by step procedure for all operations likely to be carried out during the life of the plant / equipment including, operation, maintenance, dismantling and repair including periodical activities such as chemical cleaning of the generator. Each manual shall also include a complete set of drawings together with performance/rating curves of the equipment and test certificates wherever applicable. The contract shall not be considered to be completed for purposes for taking over until these manuals have been supplied to the Owner.
- ii. If after the commissioning and initial operation of the plant, the manuals require any modification / additions / changes, the same shall be incorporated and the updated final instruction manuals shall be submitted to the Owner for records.
- iii. A separate section of the manual shall be for each size/ type of equipment and shall contain a detailed description of construction and operation, together with all relevant pamphlets and drawings.
- iv. The manuals shall include the following :
- a) List of spare parts along with their drawing and catalogues and procedure for ordering spares.
  - b) Lubrication Schedule including charts showing lubrication checking, testing and replacement procedure to be carried daily, weekly, monthly & at longer intervals to ensure trouble free operation.
  - c) Where applicable, fault location charts shall be included to facilitate finding the cause of maloperation or break down.
- v. Detailed specifications for all the consumables including lubricant oils, greases, chemicals etc. system/equipment/assembly/sub-assembly - wise required for the complete plant.
- vi. On completion of erection, a complete list of bearings / equipment giving their location, and identification marks etc. shall also be furnished to the Owner indicating lubrication method for each type/category of bearing.



2 x 660 MW Ennore SEZ Supercritical Thermal Power  
Project at Ash Dyke of NCTPS  
Spec. No. CE/C/P&E/EE/E/OT.No.03 /2013-14



8.03.02

**Drawings**

- (a.) All documents submitted by the Bidder for Owner's review shall be in electronic form (soft copies) along with the desired number of hard copies as per Annexure-I. The soft copies to be supplied shall be either in CDs, or through direct transfer via E-mail, etc. depending upon the nature/volume/size of the document. The drawings submitted for approval could be in the Image form.
- (b.) Final copies of the approved drawings shall be submitted on CD-ROM along with the requisite number of hard copies as per Annexure-I.
- (c.) The completed plant documentation with equipment drawings, data sheets, P&ID, BOQ, schematics, logic diagrams, test reports and quality plan, etc. shall be furnished to Owner.
- (d.) All documents/text information shall be in latest version of MS Office.



2 x 660 MW Ennore SEZ Supercritical Thermal Power  
Project at Ash Dyke of NCTPS  
Spec. No. CE/C/P&E/EE/E/OT.No.03 /2013-14



- (e.) All drawings submitted by the Bidder including those submitted at the time of bid shall be in sufficient detail indicating the type, size, arrangement, weight of each component for packing and shipment, the external connection, fixing arrangement required, the dimensions required for installation and interconnections with other equipment and materials, clearance and spaces required between various portions of equipment and any other information specifically requested in the drawing schedules.
- (f.) Each drawing submitted by the Bidder (including those of sub-vendors) shall bear a title block at the right hand bottom corner with clear mention of the name of the Owner, Consultant, name of the Project, system designation, the specifications title, the specification number, drawing/document number and revisions. If standard catalogue pages are submitted the applicable items shall be indicated therein. All titles, notings, markings and writings on the drawing shall be in English. All the dimensions should be in metric units.
- (g) The furnishing of detailed engineering data and drawings by the Bidder shall be in accordance with the time schedule for the project. The review of these documents/ data/ drawings by the Owner will cover only general conformance of the data/ drawings/ documents to the specifications and contract, interfaces with the equipment provided by others and external connections & dimensions which might affect plant layout. The review by the Owner should not be construed to be a thorough review of all dimensions, quantities and details of the equipment, materials, any devices or items indicated or the accuracy of the information submitted. The review and/ or approval by the Owner / Project Manager shall not relieve the Bidder of any of his responsibilities and liabilities under this contract.
- (h) After the approval of the drawings, further work by the Bidder shall be in strict accordance with these approved drawings and no deviation shall be permitted without the written approval of the Owner.
- (i) All manufacturing, fabrication and execution of work in connection with the equipment / system, prior to the approval of the drawings, shall be at the Bidder's risk. The Bidder is expected not to make any changes in the design of the equipment /system, once they are approved by the Owner. However, if some changes are necessitated in the design of the equipment/system at a later date, the Bidder may do so, but such



changes shall promptly be brought to the notice of the Owner indicating the reasons for the change and get the revised drawing approved again in strict conformance to the provisions of the Technical Specification.

(j) **As Built Drawings**

After final acceptance of individual equipment/system by the Owner, the Bidder will update all original drawings and documents for the equipment/system to "as built" conditions.

- (k) Drawings must be checked by the Bidder in terms of its completeness, data adequacy and relevance with respect to Engineering schedule prior to submission to the Owner. In case drawings are found to be submitted without proper endorsement for checking by the Bidder, the same shall not be reviewed and returned to the Bidder for re-submission.

- (l) The Bidder shall submit adequate prints of drawing/data/document for Owner's review and approval. The Owner shall review the drawings and return one (1) copy to the Bidder authorizing either to proceed with manufacture or fabrication, or marked to show changes desired. When changes are required, drawings shall be re-submitted promptly, with revisions clearly marked, for final review. Any delays arising out of the failure of the Bidder to submit/rectify and resubmit in time shall not be accepted as a reason for delay in the contract schedule.



- 8.04.00 **Engineering Progress and Exception Report**
- 8.04.01 Report giving the status of each engineering information including
- (a.) A list of drawings/engineering information which remains unapproved for more than four (4) weeks after the date of first submission
  - (b.) Drawings which were not submitted as per agreed schedule.
- 8.04.02 The draft format for this report shall be furnished to the Owner within four (4) weeks of the award of the contract, which shall then be discussed and finalized with the Owner.
- 8.05.00 **Co-Ordination Meetings**
- 8.05.01 The Bidder shall be called upon to organize and attend monthly Design/ Co-ordination Meetings with the Owner/Owner's representatives, Project Consultant during the period of contract. The Bidder shall attend such meetings at his own cost at mutually agreed venue as and when required and



2 x 660 MW Ennore SEZ Supercritical Thermal Power  
Project at Ash Dyke of NCTPS  
Spec. No. CE/C/P&E/EE/E/OT.No.03 /2013-14



8.05.02 fully co-operate with such persons and agencies involved during the discussions.  
The Bidder should note that Time is the essence of the contract. In order to expedite the early completion of engineering activities, the Bidder shall submit all drawings as per the agreed Engineering Information Submission Schedule.

The comments of the Owner shall then be discussed across the table during the above co-ordination Meetings wherein best efforts shall be made by both sides to ensure the approval of the drawing.

8.05.03 The Bidder shall ensure availability of the concerned experts / consultants/ personnel who are empowered to take necessary decisions during these meetings. The Bidder shall be equipped with necessary tools and facilities so that the drawings/documents can be resubmitted after incorporating necessary changes and approved during the meeting itself.

8.05.04 Should any drawing remain unapproved for more than six (6) weeks after it's first submission, this shall be brought out in the monthly Engineering Progress and Exception Report with reasons thereof.

8.05.05 Any delays arising out of failure by the Bidder to incorporate Owner's comments and resubmit the same during the TCM shall be considered as a default and in no case shall entitle the Bidder to alter the Contract completion date.

8.05.06

**Protective Guards**

Suitable guards shall be provided for protection of personnel on all exposed rotating and/or moving machine parts. All such guards shall be designed for easy installation and removal for maintenance purpose.



2 x 660 MW Ennore SEZ Supercritical Thermal Power  
Project at Ash Dyke of NCTPS  
Spec. No. CE/C/P&E/EE/E/OT.No.03 /2013-14



**8.06 Lubricants, Servo Fluids and Chemicals**

8.06.01 The Bidder's scope includes all the first fill and one year's topping, requirements of consumables such as oils, lubricants including grease, servo fluids, gases and essential chemicals etc. Consumption of all these consumables during the initial operation and final filling after the initial operation shall also be included in the scope of the Bidder. Bidder shall also supply a quantity not less than 10% of the full charge of each variety of lubricants, servo fluids, gases, chemicals etc. used which is expected to be utilised during the first year of operation. This additional quantity shall be supplied in separate Containers.

8.06.02 As far as possible lubricants marketed by the Indian Oil Corporation shall be used. The variety of lubricants shall be kept to a minimum possible.

Detailed specifications for the lubricating oil, grease, gases, servo fluids, control fluids, chemicals etc. required for the complete plant covered herein shall be furnished. On completion of erection, a complete list of bearings/equipment giving their location and identification marks shall be furnished to the Owner along with lubrication requirements.

**8.07 Lubrication**

8.07.01 Equipment shall be lubricated by systems designed for continuous operation. Lubricant level indicators shall be furnished and marked to indicate proper levels under both standstill and operating conditions.

**8.08 Material of Construction**

All materials used for the construction of the equipment shall be new and shall be in accordance with the requirements of this specification. Materials utilized for various components shall be those which have established themselves for use in such applications.

**8.09 Rating Plates, Name Plates & Labels**

Each main and auxiliary item of plant including instruments shall have permanently attached to it in a conspicuous position, a rating plate of non-corrosive material upon which shall be engraved manufacturer's name, equipment, type or serial number together with details of the ratings, service conditions under which the item of plant in question has been designed to operate, and such diagram plates as may be required by the Owner.

Each item of plant shall be provided with nameplate or label designating the service of the particular equipment. The inscriptions shall be approved by the Owner or as detailed in appropriate section of the technical specifications.

Such nameplates or labels shall be of white non-hygroscopic material with engraved black lettering or alternately, in the case of indoor circuit breakers, starters, etc. of transparent plastic material with suitably coloured lettering



2 x 660 MW Ennore SEZ Supercritical Thermal Power  
Project at Ash Dyke of NCTPS  
Spec. No. CE/C/P&E/EE/E/OT.No.03 /2013-14



engraved on the back. The name plates shall be suitably fixed on both front and rear sides.

All such plates, instruction plates, etc. shall be bilingual with Hindi inscription first, followed by English. Alternatively, two separate plates one with Hindi and the other with English inscriptions may be provided.

All segregated phases of conductors or bus ducts, indoor or outdoor, shall be provided with coloured phase plates to clearly identify the phase of the system



2 x 660 MW Ennore SEZ Supercritical Thermal Power  
Project at Ash Dyke of NCTPS  
Spec. No. CE/C/P&E/EE/E/OT.No.03 /2013-14



**8.10 Welding**

If the manufacturer has special requirements relating to the welding procedures for welds at the terminals of the equipment to be performed by others the requirements shall be submitted to the Owner in advance of commencement of erection work.

**8.11 Colour Code for all Equipment/ Pipings/ Pipe Services**

All equipment/ piping/ pipe services are to be painted by the Bidder in accordance with Owner's standard colour coding scheme,

**8.12 Protection and Preservative Shop Coating****Protection**

All coated surfaces shall be protected against abrasion, impact, discoloration and any other damages. All exposed threaded portions shall be suitably protected with either metallic or a nonmetallic protection device. All ends of all valves and piping and conduit equipment connections shall be properly sealed with suitable devices to protect them from damage. The parts which are likely to get rusted, due to exposure to weather, should also be properly treated and protected in a suitable manner. All primers/paints/coatings shall take into account the hot humid, corrosive & alkaline, subsoil or overground environment as the case may be.

**Preservative Shop Coating**

All exposed metallic surfaces subject to corrosion shall be protected by shop application of suitable coatings. All surfaces which will not be easily accessible after the shop assembly, shall be treated beforehand and protected for the life of the equipment. All surfaces shall be thoroughly cleaned of all mill scales, oxides and other coatings and prepared in the shop. The surfaces that are to be finish-painted after installation or require corrosion protection until installation, shall be shop painted with at least two coats of primer.

Transformers and other electrical equipment if included shall be shop finished with one or more coats of primer and two coats of high grade epoxy. The finished colors shall be as per manufacturer's standards, to be selected and specified by the Owner at a later date.



Shop primer for all steel surfaces which will be exposed to operating temperature below 95 degrees Celsius shall be selected by the Bidder after obtaining specific approval of the Owner regarding the quality of primer proposed to be applied. Special high temperature primer shall be used on surfaces exposed to temperature higher than 95 degrees Celsius and such primer shall also be subject to the approval of the Owner.

All other steel surfaces which are not to be painted shall be coated with suitable rust preventive compound subject to the approval of the Owner.

All piping shall be cleaned after shop assembly by shot blasting or other means approved by the Owner. Lube oil piping or carbon steel shall be pickled.

Painting for Civil structures shall be done as per relevant part of technical specification.



2 x 660 MW Ennore SEZ Supercritical Thermal Power  
Project at Ash Dyke of NCTPS  
Spec. No. CE/C/P&E/EE/E/OT.No.03 /2013-14



9.00

**General Requirements - Quality Assurance**

9.00.01

All materials, components and equipment covered under this specification shall be procured, manufactured, erected, commissioned and tested at all the stages, as per a comprehensive Quality Assurance Programme. An indicative programme of inspection/tests to be carried out by the Bidder for some of the major items is given in the respective technical specification. This is, however, not intended to form a comprehensive programme as it is the Bidder's responsibility to draw up and implement such programme duly approved by the Owner. The detailed Quality Plans for manufacturing and field activities shall be drawn up by the Bidder and will be submitted to Owner for approval. Schedule of finalisation of such quality plans will be finalised before award. Monthly progress reports on MQP/FQP submission/approval shall be furnished.

9.00.02

Manufacturing Quality Plan will detail out for all the components and equipment, various tests/inspection, to be carried out as per the requirements of this specification and standards mentioned therein and quality practices and procedures followed by Bidder's/ Sub-Bidder's/ sub-supplier's Quality Control Organisation, the relevant reference documents and standards, acceptance norms, inspection documents raised etc., during all stages of materials procurement, manufacture, assembly and final testing/performance testing. The Quality Plan shall be submitted on electronic media e.g. Compact Disc or E-mail in addition to hard copy, for review and approval. After approval the same shall be submitted in compiled form on CD-ROM.

9.00.03

Field Quality Plans will detail out for all the equipment, the quality practices and procedures etc. to be followed by the Bidder's "Site Quality Control Organisation", during various stages of site activities starting from receipt of materials/equipment at site.

9.00.04

The Bidder shall also furnish copies of the reference documents/plant standards/acceptance norms/tests and inspection procedure etc., as referred in Quality Plans along with Quality Plans. These Quality Plans and reference



2 x 660 MW Ennore SEZ Supercritical Thermal Power  
Project at Ash Dyke of NCTPS  
Spec. No. CE/C/P&E/EE/E/OT.No.03 /2013-14



documents/standards etc. will be subject to Owner's approval without which manufacturer shall not proceed. These approved documents shall form a part of the contract. In these approved Quality Plans, Owner shall identify customer hold points (CHP), i.e. test/checks which shall be carried out in presence of the Owner's Project Manager or his authorised representative and beyond which the work will not proceed without consent of Owner in writing. All deviations to this specification, approved quality plans and applicable standards must be documented and referred to Owner along with technical justification for approval and dispositioning.

- 9.00.05 No material shall be despatched from the manufacturer's works before the same is accepted, subsequent to predespatch final inspection including verification of records of all previous tests/inspections by Owner's Project Manager/Authorised representative and duly authorised for despatch by issuance of Material Despatch Clearance Certificate (MDCC).
- 9.00.06 All material used for equipment manufacture including casting and forging etc. shall be of tested quality as per relevant codes/standards. Details of results of the tests conducted to determine the mechanical properties; chemical analysis and details of heat treatment procedure recommended and actually followed shall be recorded on certificates and time temperature chart. Tests shall be carried out as per applicable material standards and/or agreed details.
- 9.00.07 The Bidder shall submit to the Owner Field Welding Schedule for field welding activities in the enclosed format. The field welding schedule shall be submitted to the Owner along with all supporting documents, like welding procedures, heat treatment procedures, NDT procedures etc. at least ninety days before schedule start of erection work at site.
- 9.00.08 All welding and brazing shall be carried out as per procedure drawn and qualified in accordance with requirements of ASME Section IX/BS-4870 or other International equivalent standard acceptable to the Owner.
- All welding/brazing procedures shall be submitted to the Owner or its authorised representative for approval prior to carrying out the welding/brazing.
- 9.00.09 All brazers, welders and welding operators employed on any part of the contract either in Bidder's/sub-Bidder's works or at site or elsewhere shall be qualified as per ASME Section-IX or BS-4871 or other equivalent International Standards acceptable to the Owner.
- 9.00.10 Welding procedure qualification & Welder qualification test results shall be furnished to the Owner for approval. However, where required by the Owner, tests shall be conducted in presence of Owner/authorised representative.
- 9.00.11 For all pressure parts and high pressure piping welding, the latest applicable requirements of the IBR (Indian Boiler Regulations) shall also be essentially complied with. Similarly, any other statutory requirements for the



2 x 660 MW Ennore SEZ Supercritical Thermal Power  
Project at Ash Dyke of NCTPS  
Spec. No. CE/C/P&E/EE/E/OT.No.03 /2013-14



- equipment/systems shall also be complied with. On all back-gauged welds MPI/LPI shall be carried before seal welding.
- 9.00.11 Unless otherwise proven and specifically agreed with the Owner, welding of dissimilar materials and high alloy materials shall be carried out at shop only.
- 9.00.12 No welding shall be carried out on cast iron components for repair.
- 9.00.13 All the heat treatment results shall be recorded on time temperature charts and verified with recommended regimes.
- 9.00.14 All non-destructive examination shall be performed in accordance with written procedures as per International Standards, The NDT operator shall be qualified as per SNT-TC-IA (of the American Society of non-destructive examination). NDT shall be recorded in a report, which includes details of methods and equipment used, result/evaluation, job data and identification of personnel employed and details of co-relation of the test report with the job.
- All plates of thickness above 40mm & all bar stock/Forging above 40mm dia shall be ultrasonically tested. For pressure parts, plate of thickness equal to or above 25mm shall be ultrasonically tested.
- 9.00.15 The Bidder shall list out all major items/ equipment/ components to be manufactured in house as well as procured from sub-contractors bought out items (BOI). All the sub-Bidder proposed by the Bidder for procurement of major bought out items including castings, forging, semi-finished and finished components/equipment etc., list of which shall be drawn up by the Bidder and finalised with the Owner, shall be subject to Owner's approval. The Bidder's proposal shall include vendor's facilities established at the respective works, the process capability, process stabilization, QC systems followed, experience list, etc. along with his own technical evaluation for identified sub-contractors enclosed and shall be submitted to the Owner for approval within the period agreed at the time of pre-awards discussion and identified in review category prior to any procurement. Monthly progress reports on sub-Bidder detail submission / approval shall be furnished. Such vendor approval shall not relieve the Bidder from any obligation, duty or responsibility under the contract.
- 9.00.16 For components/equipment procured by the contractors for the purpose of the contract, after obtaining the written approval of the Owner, the Bidder's purchase specifications and inquiries shall call for quality plans to be submitted by the suppliers. The quality plans called for from the sub-Bidder shall set out, during the various stages of manufacture and installation, the quality practices and procedures followed by the vendor's quality control organisation, the relevant reference documents/standards used, acceptance level, inspection of documentation raised, etc. Such quality plans of the successful vendors shall be finalised with the Owner and such approved Quality Plans shall form a part of the purchase order/contract between the Bidder and sub-Bidder. Within three weeks of the release of the purchase orders /contracts for such bought out items /components, a copy of the same without price details but together with the detailed purchase specifications,



2 x 660 MW Ennore SEZ Supercritical Thermal Power  
Project at Ash Dyke of NCTPS  
Spec. No. CE/C/P&E/EE/E/OT.No.03 /2013-14



quality plans and delivery conditions shall be furnished to the Owner on the monthly basis by the Bidder along with a report of the Purchase Order placed so far for the contract.

9.00.17 Owner reserves the right to carry out quality audit and quality surveillance of the systems and procedures of the Bidder's or their sub-Bidder's quality management and control activities. The Bidder shall provide all necessary assistance to enable the Owner carry out such audit and surveillance.

9.00.18 The Bidder shall carry out an inspection and testing programme during manufacture in his work and that of his sub-Bidder's and at site to ensure the mechanical accuracy of components, compliance with drawings, conformance to functional and performance requirements, identity and acceptability of all materials parts and equipment. Bidder shall carry out all tests/inspection required to establish that the items/equipment conform to requirements of the specification and the relevant codes/standards specified in the specification, in addition to carrying out tests as per the approved quality plan.

9.00.19 Quality audit/surveillance/approval of the results of the tests and inspection will not, however, prejudice the right of the Owner to reject the equipment if it does not comply with the specification when erected or does not give complete satisfaction in service and the above shall in no way limit the liabilities and responsibilities of the Bidder in ensuring complete conformance of the materials/equipment supplied to relevant specification, standard, data sheets, drawings, etc.

9.00.20 For all spares and replacement items, the quality requirements as agreed for the main equipment supply shall be applicable.

9.00.21 Repair/rectification procedures to be adopted to make the job acceptable shall be subject to the approval of the Owner/ authorised representative.

9.00.22 Burn in and Elevated Temperature Test Requirement for Electronics Solid State Equipment

All solid state electronic systems/equipment shall be tested as a complete system/equipment with all devices connected for a minimum of 168 hours (7 Days) continuously under energized conditions prior to shipment from manufacturing works, as per the following cycle.

#### Elevated Temperature Test Cycle

During the elevated temperature test which shall be for 48 hours of the total 168 hours of testing, the ambient temperature shall be maintained at 50 deg.C. The equipment shall be interconnected with devices which will cause it to repeatedly perform all operations it is expected to perform in actual service with load on various components being equal to those which will be experienced in actual service.

During the elevated temperature test the cubicle doors shall be closed (or shall be in the position same as they are supposed to be in the field) and



2 x 660 MW Ennore SEZ Supercritical Thermal Power  
Project at Ash Dyke of NCTPS  
Spec. No. CE/C/P&E/EE/E/OT.No.03 /2013-14



inside temperature in the zone of highest heat dissipating components/modules shall be monitored. The temperature rise inside the cubicle should not exceed 10 deg.C above the ambient temp. at 50 deg.C.

#### **Burn in Test Cycle**

The 48 hours elevated temperature test shall be followed by 120 hours of burn in test as above except that the temperature shall be reduced to the ambient temperature prevalent at that time.

During the above tests, the process I/O and other load on the system shall be simulated by simulated inputs and in the case of control systems, the process which is to be controlled shall also be simulated. Testing of individual components or modules shall not be acceptable.

In case the Bidder/ sub-Bidder is having any alternate established procedure of eliminating infant mortile components, the detail procedures followed by the Bidder/ sub- Bidder along with the statistical figures to validate the alternate procedure to be forwarded.

The Bidder/Sub-Bidder shall carry out routine test on 100% item at Bidder/sub-Bidder's works. The quantum of check/test for routine & acceptance test by Owner shall be generally as per criteria/sampling plan defined in referred standards. Wherever standards have not been mentioned quantum of check/test for routine / acceptance test shall be as agreed during detailed engineering stage.

9.02.00

#### **QA Documentation Package**

The Bidder shall be required to submit the QA Documentation in two hard copies and two CD ROMs, as identified in respective quality plan with tick (?) mark.

Each QA Documentation shall have a project specific Cover Sheet bearing name & identification number of equipment and including an index of its contents with page control on each document.

The QA Documentation file shall be progressively completed by the Supplier's sub- supplier to allow regular reviews by all parties during the manufacturing.

The final quality document will be compiled and issued at the final assembly place of equipment before despatch. However CD-Rom may be issued not later than three weeks.

9.03.01

#### **Typical contents of QA Documentation is as below:-**

- (a.) Quality Plan
- (b.) Material mill test reports on components as specified by the specification and approved Quality Plans.



2 x 660 MW Ennore SEZ Supercritical Thermal Power  
Project at Ash Dyke of NCTPS  
Spec. No. CE/C/P&E/EE/E/OT.No.03 /2013-14



- (c.) Manufacturer / works test reports/results for testing required as per applicable codes and standard referred in the specification and approved Quality Plans.
- (d.) Non-destructive examination results /reports including radiography interpretation reports. Sketches/drawings used for indicating the method of traceability of the radiographs to the location on the equipment.
- (e.) Heat Treatment Certificate/Record (Time- temperature Chart)
- (f.) All the accepted Non-conformance Reports (Major/Minor) / deviation, including complete technical details / repair procedure).
- (g.) CHP / Inspection reports duly signed by the Inspector of the Owner and Bidder for the agreed Customer Hold Points.
- (h.) Certificate of Conformance (COC) wherever applicable.
- (i.) MDCC

9.03.02

Similarly, the Bidder shall be required to submit two sets (two hard copies and two CD ROMs), containing QA Documentation pertaining to field activities as per Approved Field Quality Plans and other agreed manuals/ procedures, prior to commissioning of individual system.

9.03.03

Before despatch / commissioning of any equipment, the Supplier shall make sure that the corresponding quality document or in the case of protracted phased deliveries, the applicable section of the quality document file is completed. The supplier will then notify the Inspector regarding the readiness of the quality document (or applicable section) for review.

- (a.) If the result of the review carried out by the Inspector is satisfactory, the Inspector shall stamp the quality document (or applicable section) for release.
- (b.) If the quality document is unsatisfactory, the Supplier shall endeavor to correct the incompleteness, thus allowing to finalize the quality document (or applicable section) by time compatible with the requirements as per contract documents. When it is done, the quality document (or applicable section) is stamped by the Inspector.
- (c.) If a decision is made despatch, whereas all outstanding actions cannot be readily cleared for the release of the quality document by that time. The supplier shall immediately, upon shipment of the equipment, send a copy of the quality document Review Status signed by the Supplier Representative to the Inspector and notify of the committed date for the completion of all outstanding actions & submission. The Inspector shall stamp the quality document for applicable section when it is effectively completed. The submission of



2 x 660 MW Ennore SEZ Supercritical Thermal Power  
Project at Ash Dyke of NCTPS  
Spec. No. CE/C/P&E/EE/E/OT.No.03 /2013-14



QA documentation package shall not be later than 3 weeks after the despatch of equipment.

9.03.03

#### **Transmission Of QA Documentation**

On release of QA Documentation by Inspector, one set of quality document shall be forwarded to Corporate Quality Assurance Department and other set to respective Project Site of Owner.

For the particular case of phased deliveries, the complete quality document to the Owner shall be issued not later than 3 weeks after the date of the last delivery of equipment.

9.04.00

#### **Project Manager's Supervision**

9.04.01

To eliminate delays and avoid disputes and litigation, it is agreed between the parties to the Contract that all matters and questions shall be referred to the Project Manager and without prejudice to the provisions of 'Arbitration' clause in Section General Conditions of Contract, the Bidder shall proceed to comply with the Project Manager's decision.

9.04.02

The work shall be performed under the supervision of the Project Manager. The scope of the duties of the Project Manager pursuant to the Contract, will include but not be limited to the following:

- (a.) Interpretation of all the terms and conditions of these documents and specifications:
- (b.) Review and interpretation of all the Bidder's drawing, engineering data, etc:
- (c.) Witness or his authorised representative to witness tests and trials either at the manufacturer's works or at site, or at any place where work is performed under the contract :
- (d.) Inspect, accept or reject any equipment, material and work under the contract.
- (e.) Issue certificate of acceptance and/or progressive payment and final payment certificates
- (f.) Review and suggest modifications and improvement in completion schedules from time to time, and
- (g.) Supervise Quality Assurance Programme implementation at all stages of the works.

9.05.00

#### **Inspection, Testing And Inspection Certificates**

9.05.01

The word 'Inspector' shall mean the Project Manager and/or his authorized representative and/or an outside inspection agency acting on behalf of the



2 x 660 MW Ennore SEZ Supercritical Thermal Power  
Project at Ash Dyke of NCTPS  
Spec. No. CE/C/P&E/EE/E/OT.No.03 /2013-14



- Owner to inspect and examine the materials and workmanship of the works during its manufacture or erection.
- 9.05.02 The Project Manager or his duly authorized representative and/or an outside inspection agency acting on behalf of the Owner shall have access at all reasonable times to inspect and examine the materials and workmanship of the works during its manufacture or erection and if part of the works is being manufactured or assembled on other premises or works, the Bidder shall obtain for the Project Manager and for his duly authorized representative permission to inspect as if the works were manufactured or assembled on the Bidder's own premises or works.
- 9.05.03 The Bidder shall give the Project Manager/Inspector fifteen (15) days written notice of any material being ready for testing. Such tests shall be to the Bidder's account except for the expenses of the Inspector's. The Project Manager/Inspector, unless the witnessing of the tests is virtually waived and confirmed in writing, will attend such tests within fifteen (15) days of the date on which the equipment is noticed as being ready for test/inspection failing which the Bidder may proceed with test which shall be deemed to have been made in the inspector's presence and he shall forthwith forward to the inspector duly certified copies of test reports in two (2) copies.
- 9.05.04 The Project Manager or Inspector shall within fifteen (15) days from the date of inspection as defined herein give notice in writing to the Bidder, or any objection to any drawings and all or any equipment and workmanship which is in his opinion not in accordance with the contract. The Bidder shall give due consideration to such objections and shall either make modifications that may be necessary to meet the said objections or shall inform in writing to the Project Manager/Inspector giving reasons therein, that no modifications are necessary to comply with the contract.
- 9.05.05 When the factory tests have been completed at the Bidder's or sub-Bidder's works, the Project Manager /Inspector shall issue a certificate to this effect fifteen (15) days after completion of tests but if the tests are not witnessed by the Project Manager /Inspectors, the certificate shall be issued within fifteen (15) days of the receipt of the Bidder's test certificate by the Project Manager /Inspector. Project Manager /Inspector to issue such a certificate shall not prevent the Bidder from proceeding with the works. The completion of these tests or the issue of the certificates shall not bind the Owner to accept the equipment should it, on further tests after erection be found not to comply with the contract.
- 9.05.06 In all cases where the contract provides for tests whether at the premises or works of the Bidder or any sub-Bidder, the Bidder, except where otherwise specified shall provide free of charge such items as labour, material, electricity, fuel, water, stores, apparatus and instruments as may be reasonably demanded by the Project Manager /Inspector or his authorized representatives to carry out effectively such tests on the equipment in accordance with the Bidder and shall give facilities to the Project Manager/Inspector or to his authorized representative to accomplish testing.



2 x 660 MW Ennore SEZ Supercritical Thermal Power  
Project at Ash Dyke of NCTPS  
Spec. No. CE/C/P&E/EE/E/OT.No.03 /2013-14



- 9.05.07 The inspection by Project Manager / Inspector and issue of Inspection Certificate thereon shall in no way limit the liabilities and responsibilities of the Bidder in respect of the agreed Quality Assurance Programme forming a part of the contract.
- 9.05.08 To facilitate advance planning of inspection in addition to giving inspection notice as specified at clause no 9.05.03- of this chapter, the Bidder shall furnish quarterly inspection programme indicating schedule dates of inspection at Customer Hold Point and final inspection stages. Updated quarterly inspection plans will be made for each three consecutive months and shall be furnished before beginning of each calendar month.
- 9.05.09 All inspection, measuring and test equipment used by Bidder shall be calibrated periodically depending on its use and criticality of the test/measurement to be done. The Bidder shall maintain all the relevant records of periodic calibration and instrument identification, and shall produce the same for inspection by the Owner. Wherever asked specifically, the Bidder shall re-calibrate the measuring/test equipment in the presence of Project Manager/Inspector.
- 9.06.00 **Associated document for quality assurance programme:**
- 9.06.01 List of items requiring quality plan and sub supplier approval. (Annexure-III).
- 9.06.02 Status of items requiring Quality Plan and sub supplier approval. (Annexure-IV).
- 9.06.03 Field Welding Schedule (Annexure-V).
- 9.06.04 Manufacturing Quality Plan (Annexure-VI).
- 9.06.05 Field Quality Plan (Annexure-VII).
- 10.00.00 PRE-COMMISSIONING AND COMMISSIONING FACILITIES**
- (a.) As soon as the facilities or part thereof has been completed operationally and structurally and before start-up, each item of the equipment and systems forming part of facilities shall be thoroughly cleaned and then inspected jointly by the Owner and the Bidder for correctness of and completeness of facility or part thereof and acceptability for initial pre-commissioning tests, commissioning and start-up at Site. The list of pre-commissioning tests to be performed shall be as mutually agreed and included in the Bidder's quality assurance programme as well as those included elsewhere in the Technical Specifications.
- (b.) The Bidder's pre-commissioning/ commissioning/start-up engineers, specially identified as far as possible, shall be responsible for carrying out all the pre-commissioning tests at Site. On completion of inspection, checking and after the pre-commissioning tests are satisfactorily over, the commissioning of the complete facilities shall



be commenced during which period the complete facilities, equipment shall be operated integral with sub-systems and supporting equipment as a complete plant.

It will be the responsibility of the Bidder to assess and furnish a list of all commissioning spares required for successful commissioning of all the equipment covered under the contract.

separately for each equipment and shall be reviewed by the Owner and discussed for mutual agreement. The commissioning spares will be so identified as not to allow the trial operation to suffer for want of such commissioning spares. The identification of commissioning spares will not in any way relieve the Bidder of any of his responsibilities of satisfactory performance under the provisions of other conditions of contract. All the commissioning spares shall be deemed to be included in scope of the Bidder as a part of the respective equipment package at no extra cost to the Owner.

- (C) The check outs during the pre - commissioning period should be programmed to follow the construction completion schedule. Each equipment/system, as it is completed in construction and turned over to Owner's commissioning (start-up) Engineer(s), should be checked out and cleaned. The checking and inspection of individual systems should then follow a prescribed commissioning documentation [SLs (Standard Check List) / TS (Testing Schedule) / CS (Commissioning Schedule)] approved by the Owner.
- (d) The Bidder during initial operation and performance testing shall conduct vibration testing to determine the 'base line' of performance of all plant rotating equipment. These tests shall be conducted when the equipment is running at the base load, peak load as well as lowest sustained operating condition as far as practicable.



10.00.01 )

**Guarantee Tests**

- a) The final test as to prove the Functional Guarantees shall be conducted at Site by the Bidder in presence of the Owner. The Bidder's Commissioning, Start-up Purchaser shall make the unit ready to conduct such test.
- b) These tests shall be binding on both the parties of the Contract to determine compliance of the equipment with the functional guarantee.



2 x 660 MW Ennore SEZ Supercritical Thermal Power  
Project at Ash Dyke of NCTPS  
Spec. No. CE/C/P&E/EE/E/OT.No.03 /2013-14



- c) For performance/ demonstration tests instrumentations, of accuracy class, to the approval of the Owner shall be used. The numbers and location of the instruments shall be as per the specified test codes. In addition the values of parameters shall be logged from the information system provided under Owner's Distributed Digital Control Monitoring and Information system. Test will be conducted at specified load points.
- d) Any special equipment, tools and tackles required for the successful completion of the Guarantee Tests shall be provided by the Bidder, free of cost.
- e) The Guarantee tests and specific tests to be conducted on equipment have been brought out in detail elsewhere in the specification.

#### 11.00.00 TAKING OVER

Upon successful completion of Initial Operations and all the tests other than guarantee tests conducted to the Owner's satisfaction, the Owner shall issue to the Bidder a Taking over Certificate as a proof of the final acceptance of the equipment. Such certificate shall not unreasonably be withheld nor will the Owner delay the issuance thereof, on account of minor omissions or defects which do not affect the commercial operation and/or cause any serious risk to the equipment. Such certificate shall not relieve the Bidder of any of his obligations which otherwise survive, by the terms and conditions of the Contract after issuance of such certificate.



2 x 660 MW Ennore SEZ Supercritical Thermal Power  
Project at Ash Dyke of NCTPS  
Spec. No. CE/C/P&E/EE/E/OT.No.03 /2013-14



12.00

**SAFETY ASPECTS DURING CONSTRUCTION AND ERECTION**

In addition to the requirements given in Erection Conditions of Contract (ECC) the following shall also cover:

- (a.) Working platforms should be fenced and shall have means of access.
- (b.) Ladders in accordance with Owner's safety rules for construction and erection shall be used. Rungs shall not be welded on columns. All the stairs shall be provided with handrails immediately after its erection.



2 x 660 MW Ennore SEZ Supercritical Thermal Power  
Project at Ash Dyke of NCTPS  
Spec. No. CE/C/P&E/EE/E/OT.No.03 /2013-14



13.00

**NOISE LEVEL**

The equivalent 'A' weighted sound pressure level measured at a height of 1.0 m above floor level in elevation and at a distance of one (1) meter horizontally from the nearest surface of any equipment / machine, furnished and installed under these specifications, expressed in decibels to a reference of 0.0002 microbar, shall not exceed 85 dBA except for

14.00

**PACKAGING AND TRANSPORTATION**

All the equipment & spares shall be suitably protected, coated, covered or boxed and crated to prevent damage or deterioration during transit, handling and storage at Site till the time of erection. Each spare shall be clearly marked or labeled on the outside of the packing with its description. When more than one spare part is packaged in a single case, a general description of the contents shall be shown on the outside of such a case and other packages must be suitably marked and numbered for the purpose of identification. All cases, containers or packages, are liable to be opened for such examination as may be considered reasonable by the Engineer. In case of equipment supplied with grease/lubricants from imported origin, the supplied shall clearly indicate the indigenous equivalent of the grease/lubricant and source of supply so as to enable the Owner to procure these items from indigenous sources. While packing all the materials, the limitation from the point of view of the sizes of railway wagons available in India should be taken account of. The Bidder shall be responsible for any loss or damage during transportation, handling and storage due to improper packing. The Bidder shall ascertain the availability of Railway wagon sizes from the Indian Railways or any other agency concerned in India well before effecting dispatch of equipment. Before dispatch it shall be ensured that complete processing and manufacturing of the components is carried out at shop, only restricted by transport limitation, in order to ensure that site works like grinding, welding, cutting & pre-assembly to bare minimum. The Owner's Inspector shall have right to insist for completion of works in shops before dispatch of materials for transportation.

15.00

**ELECTRICAL ENCLOSURE**

All electrical equipment and devices, including insulation, heating and ventilation devices shall be designed for ambient temperature and a maximum relative humidity as specified elsewhere in the specification.



2 x 660 MW Ennore SEZ Supercritical Thermal Power  
Project at Ash Dyke of NCTPS  
Spec. No. CE/C/P&E/EE/E/OT.No.03 /2013-14



## ANNEXURE-I

S. NO.	DESCRIPTION OF MANUALS	NO OF PRINTS (sets)	NO. OF CD- ROMs (sets)
1.	PLANT DEFINITION MANUAL-	-	3 CD-ROMs
2.	Drawings "FOR APPROVAL"	10	Soft Copy
3.	Drawings "FOR INFORMATION"	10	Soft Copy
4.	Drawings "FINAL APPROVED DRAWING"	8	Soft Copy
5.	Drawings "AS BUILT "	8	3 CD-ROMs
6	DATASHEETS,DESIGNCALCULATIONS,PURCHASE SPECIFICATIONS, etc. and Other type of documents		
	i) For Approval	10	SOFT COPY
	ii) FINAL	8	3 CD-ROMs -
	iii) Analysis reports of equipment/ piping/ structures components/ systems employing software packages as detailed in the specifications		
	a) Input	10	SOFT COPY
	b) Output	10	SOFT COPY
	c) Drawings/ Sketches	10	SOFT COPY
7	Erection manual "FINAL"	8	3CD ROMS
8	Operation & Maintenance manual	10	3CD ROMS
9	Plant Hand Book "DRAFT"	6	SOFT COPY
10	Plant Hand Book "FINAL"	15	3CD ROMS
11	Commissioning and Performance Procedure manual	10	3CD ROMS
12	Performance and Functional Guarantees test report	6	3CD ROMS
13	Progress Reports	6	3CD ROMS
14	Project completion report	10	3CD ROMS
15	QA programme including	1	



2 x 660 MW Ennore SEZ Supercritical Thermal Power  
Project at Ash Dyke of NCTPS  
Spec. No. CE/C/P&E/EE/E/OT.No.03 /2013-14



S. NO.	DESCRIPTION OF MANUALS	NO OF PRINTS (sets)	NO. OF CD- ROMs (sets)
	Organization for implementation and QA system manual (with revision-servicing)		
16	Vendor details in respect of proposed vendors including Bidder's evaluation report.	1	
17	Manufacturing QPs, Field QPs, Field welding schedules and their reference documents like test procedures, WPS, POR etc.		
	(i) For review/comment	3	
	(ii) For final approval	4	1 set CD ROMS
18	Welding Manual, Heat Treatment Manuals, Storage & preservation manuals	4	
	Final	4	2 CD ROMS
19	Monthly Vendor Approval and QP approval status	2	1 CD ROM
20	QA Documentation Package for items / equipment manufactured and dispatched to site	2	2 CD ROMS
21	QA Documentation Package for field activities on equipment/systems at site	2	2 CD ROMS



2 x 660 MW Ennore SEZ Supercritical Thermal Power  
Project at Ash Dyke of NCTPS  
Spec. No. CE/C/P&E/EE/E/OT.No.03 /2013-14



**ANNEXURE-III**

		LIST OF ITEMS REQUIRING QUALITY PLAN AND SUB-SUPPLIER APPROVAL				DOC. NO.:				
		SUB-SYSTEM:				REV. NO.:				
						DATE :				
						PAGE : OF				
S. N.	Item	QP/ Insp. Cat.	QP No.	QP Sub. Schedule	QP approval schedule	Proposed sub-supplier	Place	Sub-suppliers approval status/ category	Sub-supplier Details submission schedule	Remarks

**LEGENDS**

**1. SYSTEM SUPPLIER/SUB-SUPPLIER APPROVAL STATUS CATEGORY (SHALL BE FILLED BY the Owner)**  
**A** – For these items proposed vendor is acceptable to the Owner. To be indicated with letter "A" in the list alongwith the condition of approval, if any.  
**DR** – For these items "Detailed required" for the Owner review. To be identified with letter "DR" in the list.  
**NOTED** – For these items vendors are approved by Main Supplier and accepted by the Owner without specific vendor approval from the Owner. To be identified with "NOTED".

**2. QP/INSPN CATEGORY:**  
**CAT-I** : For these items the Quality Plans are approved by the Owner and the final acceptance will be on physical inspection witness by the Owner.  
**CAT-II** : For these items the Quality Plans approved by the Owner. However no physical inspection shall be done by the Owner. The final acceptance by the Owner shall be on the basis review of documents as per approved QP.  
**CAT-III** : For these items Main Supplier approves the Quality Plans. The final acceptance by the Owner shall be on the basis certificate of conformance by the main supplier.

**UNITS/WORKS** : Place of manufacturing Place of Main Supplier of multi units/works.



2 x 660 MW Ennore SEZ Supercritical  
Thermal Power Project at Ash Dyke of NC.TPS  
Spec. No. CE/C/P&E/EE/E/OT.No.03/2013-14





**ANNEXURE-V**

Sl. No.	DRG No. for Weld Location and Identification mark	Description of parts to be welded	Material of Spec.	Dimensions	Process of welding	Type of Weld	Electrode filler No. spec.	Min. pre-heat	Heat treatment		NDT method/Quantum	REF Spec. No.	ACC Norm Ref.	Remarks
									Temp.	Holdin g time				
<p>Project : _____ Stage : _____ DOC. NO.:</p> <p>Bidder : _____ (To be raised by the Bidder) REV. NO.:</p> <p>Bidder No. : _____ Welding Code: ..... DATE : _____</p> <p>System : _____ PAGE : _____ OF _____</p>														
<p>NOTES:</p>														
<p>SIGNATURE</p>														



2 x 660 MW Ennore SEZ Supercritical  
Thermal Power Project at Ash Dyke of NCTPS  
Spec. No. CE/C/P&E/EE/OT.No.03/2013-14



ANNEXURE-VI

SL. NO	COMPONENT & OPERATIONS	CHARACTERISTICS	CLASS	TYPE OF CHECK	QUANTITY OF CHECK	REFERENCE DOCUMENT	ACCEPTANCE NORMS	FORMAT OF RECORD	AGENCY		REMARKS
									M	C N	
1.	2.	3.	4.	5.	6.	7.	8.	9.	**	10.	11.
MANUFACTURER'S NAME AND ADDRESS		MANUFACTURING QUALITY PLAN ITEM :		SUB-SYSTEM:		PROJECT PACKAGE :		CONTRACT NO. :		MAIN-SUPPLIER:	
MFGR.'s LOGO		QP NO.:		REV.NO.:		DATE:		PAGE: .... OF ....		DOC. NO.:	
MANUFACTURER/ SUB-SUPPLIER		MAN-SUPPLIER		THE		INSPECTION AGENCY, OWNER		FOR THE		REV..... CAT.....	

**LEGEND:** \* RECORDS, IDENTIFIED WITH "TICK" (✓) SHALL BE ESSENTIALLY INCLUDED BY SUPPLIER IN QA DOCUMENTATION.  
 \*\* M: MANUFACTURER/SUB-SUPPLIER  
 C: SUPPLIER/NOMINATED INSPECTION AGENCY, OWNER  
 N: THE



2 x 660 MW Ennore SEZ Supercritical  
Thermal Power Project at Ash Dyke of NCTPS  
Spec. No. CE/C/P&E/EE/OT.No.03/2013-14



PEM-6666-0



**Technical Specification for**  
Double girder EOT cranes for  
BFP,Sea Water intake pump house  
(Up to 50TCap)

SPECIFICATION NO. PE-TS-412-501-A101

VOLUME II - B

SECTION -C

REV 00

DATE :June 2015

**VOLUME - IIB**  
**SECTION – C**  
**SPECIFIC TECHNICAL REQUIREMENTS**



**Technical Specification for**  
**Double girder EOT cranes for**  
**BFP,Sea Water intake pump house**  
**(Up to 50TCap)**

SPECIFICATION NO. PE-TS-412-501-A101

VOLUME II - B

SECTION -C

REV 00

DATE :June 2015

**1.0.0. SCOPE OF WORK****1.1.0. SUPPLIES**

1.1.1. Equipment and services to be furnished by the bidder for the EOT CRANES with accessories as per the details given in the technical specification and data sheet A. Any equipment / accessories not specified in the specification but required to make the **EOT cranes** complete and efficient operation shall also be under the bidder's scope of work.

1.1.2. Compliance with this specification shall not relieve the bidder of the responsibility of furnishing material and workmanship to meet the specified working/duty conditions.

1.1.3. Crane shall include but not be limited to the following: -

- a. Bridge girders
- b. End carriages with wheels
- c. Crab
- d. CT/ LT drive arrangement
- e. All electrical equipment including cables and panels.
- f. PVC insulated shrouded bus bar Cu conductor DSL
- g. Earthing arrangement.
- h. Fill of lubricant till commissioning of cranes and One year's topping.
- i. Painting of cranes and accessories.
- j. Temporary cables for operation of each crane during erection stage of the plant (Half the bay length + 25m)
- k. Rail
- l. Maintenance tools & Tackle
- m. Erection & Commissioning spares
- n. Mandatory Spares
- o. Isolating switch in enclosure at operating floor for disconnecting supply to DSL while maintaining the crane.
- p. One Single leg sling with ring at both ends for BFP crane (for 14M length, for lifting 35T cap. equipment ( considering each ring of sling on either side of the equipment i.e. two falls) as per relevant IS standard)



**Technical Specification for**  
**Double girder EOT cranes for**  
**BFP,Sea Water intake pump house**  
**(Up to 50TCap)**

SPECIFICATION NO. PE-TS-412-501-A101

VOLUME II - B

SECTION -C

REV 00

DATE :June 2015

- q. One Single leg sling with ring at both ends for Sea water intake Pump house crane (One Lot- for 10M length, for lifting 25T cap. equipment ( considering each ring of sling on either side of the equipment i.e. two falls) as per relevant IS standard)

#### 1.1.4 Maintenance Tools and Tackles

A complete unused new set of special purpose tools, tackles and accessories along with detailed instructions and maintenance manual for the crane shall be supplied. Each tool and wrench shall be stamped so as to be identified, easy for its use. The tools shall be supplied in steel toolbox and with a copy of instruction manual. The items supplied shall be of the best quality and specially protected against rusting in tropical climate and minimum the following shall be provided.

S-No.	Description	Qty.
1	Complete set of ring spanners (Indicate the sizes offered)	1 Set
2	Complete set of screwdrivers (Min. 6 Nos., Indicate the sizes)	1 Set
3.	Adjustable Spanner	1 No.
4.	Insulated plier	1 No.
5	Wrench spanner	1 No.
6.	Grease Gun	1 No.
7.	Oil Gun.	1 No.
8.	Hand Lamp.	1 No.
9	Line tester	1 No.

Note: - One set of tool and tackles with O&M manual in the toolbox shall be supplied.

- 1.1.5 Mandatory Spares: A complete unused and new set of Mandatory Spare parts shall be supplied. Each part shall be stamped so as to be identified, easy for it use. The items supplied shall be of the best quality and specially protected against rusting in tropical climate. The minimum requirement of mandatory spare parts is listed in Annexure –II section-C, volume II-B of this specification.



**Technical Specification for**  
**Double girder EOT cranes for**  
**BFP,Sea Water intake pump house**  
**(Up to 50TCap)**

SPECIFICATION NO. PE-TS-412-501-A101

VOLUME II - B

SECTION -C

REV 00

DATE :June 2015

### 1.1.6 Erection and Commissioning spares

The Bidder shall also supply erection & commissioning spares along with his main Equipment as per his experience, for replacement of damaged or unserviceable parts during the execution of the project at site, to avoid delay in the project schedule. This shall form part of the main equipment supply. The Purchaser shall retain the unutilized commissioning spares. Fill of lubricants, oil etc. till commissioning of both cranes shall also be supplied by the bidder. (The Bidder's scope includes all the first fill and one year's topping, requirements of consumables such as oils, lubricants including grease, servo fluids, gases and essential chemicals etc. Consumption of all these consumables during the initial operation and final filling after the initial operation shall also be included in the scope of the Bidder. Bidder shall also supply a quantity not less than 10% of the full charge of each variety of lubricants, servo fluids, gases, chemicals etc. used which is expected to be utilised during the first year of operation. This additional quantity shall be supplied in separate Containers).

### 1.2.0 Services to be provided by the bidder

1.2.1. Packing, forwarding and transportation to site, storage and handling at site.

1.2.2. Arranging test load at site

Collecting the test load at site within a radius of 1 KM from owner's storage to final testing bed of crane shall be under bidder's scope of work. Test load in the form of rolled steel, plates, girder, angle etc., as available at the site shall be made available by the purchaser. The test load shall be put back to the place from where it was lifted by the vendor, after the load testing. Load testing sling, cradles and any other item required by the vendor during the load testing shall be arranged by the vendor at no extra cost to the purchaser. Slings & cradles will be allowed to be taken back by the vendor, after completion of the test at site.

1.2.3 Erection and Commissioning

1.2.4 Performance test

1.2.5 Obtaining clearance and acceptance certificate from the concerned competent authority after site test. Necessary fees/expenditure as required shall be borne by the supplier.



**Technical Specification for**  
**Double girder EOT cranes for**  
**BFP,Sea Water intake pump house**  
**(Up to 50TCap)**

SPECIFICATION NO. PE-TS-412-501-A101

VOLUME II - B

SECTION -C

REV 00

DATE :June 2015

### 1.3.0. Inspection and Testing

#### 1.3.1. Inspection and testing at Manufacturer's works

Copy of documents approved with stamp and signature (one set) shall be available at The place of Inspection. This is to be ensured by supplier.

Shop inspection and tests will include but not limited to the following –

#### A. STAGE INSPECTION.

- i) Identification, co-relation and verification of material test certificates for the important components like girders, major load carrying components, cross head, hooks, gears, shafts, wheels, wire rope drum, wire rope etc. In absence of Original copy of Mill Test Certificates/ photocopy certified by Mill in original, check test to be carried out and original test certificates to be furnished for each heat/ thickness. For other components supporting test certificates or random check tests shall be conducted / furnished. All test certificates shall be in original and legible. Photocopies certified by Mill/ manufacturer of raw material used, are acceptable.  
 For tensile testing of hooks/ forgings, samples shall be drawn from the full cross section of the shank diameter of hooks/ forgings Samples forged to reduced cross section for testing purposes is not acceptable. **Hooks shall be manufactured from Blooms, billets, rounds by forging with forging ratio of at least 3:1. Hooks manufactured from plates are not acceptable.**
- ii) Welding procedures and welders shall be qualified as per ASME Sec IX . Only qualified welders shall be employed on the job.
- iii) 100% radiography of tension zone & 25% radiography of compression zone on butt welds of load bearing members shall be carried out with acceptance norms as per ASME Sec VIII Div.1 UW 51. DP test of all butt welds shall be carried out as per ASTM E 165/ ASTM E 109 with acceptance norms as per ASME Sec VIII Div.1 append.8. Radiographs shall be inspected to a sensitivity of 2%.
- iv) For fillet welds visual inspection on all welds. Die- penetration test (DPT) for fillet welds in the load bearing members as per ASME-165/ASTME 109 and acceptance norm as per ASME section VIII Div. 1.
- v) Ultrasonic test on forgings and casting of critical components like **cross head** (hook suspension block), Hooks, Shafts, Axles, Gears, Wheels, Pulleys etc. Ultrasonic test on forgings shall be carried out as per norms given below. UT shall be carried out in



**Technical Specification for**  
**Double girder EOT cranes for**  
**BFP,Sea Water intake pump house**  
**(Up to 50TCap)**

SPECIFICATION NO. PE-TS-412-501-A101

VOLUME II - B

SECTION -C

REV 00

DATE :June 2015

Proof machined condition (single diameter/ Flat surface without steps, keyways, teeth cutting or other profile machining which can create difficulty in ultrasonic testing). Components shall be identified with Heat number and serial number by punching). Hardening operation shall be carried out prior to Ultrasonic testing.

Unacceptable defects in forgings are as given below:

1. Cracks, flakes, seams and laps
2. Defects giving indication larger than '4 (four) mm diameter equivalent flaw' except for wheels for which Defects giving indication larger than '6 (six) mm diameter equivalent flaw.'
3. Group of defects with maximum indication less than that from a 4 mm dia. equivalent flaw which cannot be separated at testing sensitivity if the back echo is reduced by 50% except for wheels for which Group of defects with maximum indication less than that from a 6 mm dia. equivalent flaw which cannot be separated at testing sensitivity if the back echo is reduced by 40%.
4. Defects giving indication of 2 to 4 mm dia. equivalent flaw, separated by a distance less than 4 (four) times the size of the larger of the adjacent flaws except for wheels for which Defects giving indication of 3 to 6 mm dia. Equivalent flaw, separated by a distance less than 4 (four) times the size of the larger of the adjacent flaws Ultrasonic test on Castings shall be carried out as per ASTM E 609.

Wherever, the Quality plan calls for witness of Ultrasonic test by BHEL or BHEL's representative, the material shall be offered for UT in proof machined condition as stated above and hard stamping and subsequent stamp transferring by BHEL shall be followed at subsequent stages to ensure trace ability.

- vi. Dye penetration check/ Magnetic particle check on surfaces subjected to hardening process as per ASTM E 165 / ASTM E 138 respectively with acceptance norms as per ASME Sec. VIII Div.1 append.7 for DP check and ASME Sec. VIII Append. 6 for Magnetic particle check.
- vii. Gear boxes shall be checked at No load for backlash, tooth contact, noise and vibration as per Procedure No. PEM (Q)/001 enclosed (attached after Section C)
- viii. Test certificates shall be furnished for verification of Type tests including environmental tests - for electrical and electro-mechanical items. If Type tests for



**Technical Specification for**  
**Double girder EOT cranes for**  
**BFP,Sea Water intake pump house**  
**(Up to 50TCap)**

SPECIFICATION NO. PE-TS-412-501-A101

VOLUME II - B

SECTION -C

REV 00

DATE :June 2015

items with similar / identical construction are not available, arrangement shall be made to conduct the same in the presence of BHEL/ Customer's representative (as required). Type test Certificates shall be considered valid if the date of test is within previous five years of the date on which ordered items are offered for inspection/ verification

- ix Acceptance and routine tests (HV and insulation) for all electrical and electro-mechanical components and system as per governing specification
- x. Functional and simulated operation test, sequencing, interlocks, safety, protection and alarm system shall be carried out for Control Panels. Test on CRANE / CRAB motors and other mechanical, electrical, electromechanical as per BHEL technical specification and / or as per applicable code.

**B. FINAL INSPECTION- Testing At Works.**

Cranes shall be completely assembled at manufacturer's works to check the misalignment of gears, shafts and other items. Gears shall be run idle for at least 4 (four) hours. Following minimum tests shall be conducted on the crane at the works of the manufacturer:

- a) Deflection test of bridge girder at rated load. Crane shall rest on centerline of LT wheels.
- b) Load test and Overload test (running of CT and Hoisting mechanism at 125% of the rated load). Capability of crane to lift the overload from mid-air shall be demonstrated.
- c) Electrical tests for brakes, panel, electrical equipment etc. as per IS - 3177
- d) All Other tests as per IS-3177.

Based on the Quality Plan and witness stages of BHEL & customer, supplier shall submit an inspection plan.

**Note: Refer annexue-III, section-C, volume II-B for "Shop test Procedure for Load/Overload testing of T.G. Hall EOT cranes at Manufacturer's Works.**

**1.3.2 Testing at site**

- a) All the tests as mentioned against S.N. 1.3.1 (B) above.
- b) Speed test at rated load for hoisting / CT and LT mechanism.
- c) Brake test.



**Technical Specification for**  
**Double girder EOT cranes for**  
**BFP,Sea Water intake pump house**  
**(Up to 50TCap)**

SPECIFICATION NO. PE-TS-412-501-A101

VOLUME II - B

SECTION -C

REV 00

DATE :June 2015

d) The test shall be carried out with actual panel, RRC, Master Controller etc.

#### 1.4.0. PAINTING & COLOUR SCHEME

**Bidder to refer SECTION –C VOLUME II B**

#### 2.0.0. Works Excluded

- 2.1.0 The purchaser shall provide one (1) no. 415V, 3 phase and 50Hz 3 wire Neutral solidly grounded power feeder at any point in the middle of the bay as specified in the Data sheet A. Bidder shall provide main isolating switch / change over switch at 1.5 M above the operating floor level and cable required from isolating switch to DSL. Any other supply required by the bidder shall be arranged by the bidder using suitable transformer as per the specification.

#### 3.0.0. Number of drawing and documents for submission

The number of prints / copies required for various drawing and documents are listed in Annexure –V, section-C, volume II-B of this specification.

#### 4.0.0. Deviations

If the offer submitted has got any deviation from the technical stipulations in the tender document, bidder shall tabulate the same in the format of “Schedule of Deviations” attached in volume III and furnishing full particular of such deviations. Deviations are to be furnished with mention to specific clause number (reasons / explanations for such deviations shall be furnished). Notes / comments etc. is not acceptable. If there are no deviations from the tender document, bidder shall mention “**NO DEVIATION**’ in deviation format.

#### 5.0.0. Performance tests

EOT crane along with its drives, controls and other accessories shall be checked for the rated capacity against the rated speed of motions and for the service conditions specified.

The bidder shall have the full responsibility for the safe and efficient operation of the crane with associated accessories as a single unit. If the shop/site performance tests



**Technical Specification for**  
**Double girder EOT cranes for**  
**BFP,Sea Water intake pump house**  
**(Up to 50TCap)**

SPECIFICATION NO. PE-TS-412-501-A101

VOLUME II - B

SECTION -C

REV 00

DATE :June 2015

indicate the failure of any of the components to achieve the desired performance, the deficiency shall be made good at bidder's cost.

Performance test shall be carried out each time after the rectification /modification is carried out.

Performance test of the crane shall include load tests and speeds in various motions at bidder's works as well as site.

**6.0.0. Makes of Sub - Vendor items**

Makes of bought out items as per Annexure-I, section C, volume II-B of the specification is for reference only. Sub vendor list shall be subject to customer approval and same shall not have any impact on manufacturing, delivery schedule and cost of the crane.

**7.0.0. Drawing & Documents to be attached with Tender:-**

Refer Volume-III

**8.0.0** Parameter and tolerances for structural assembly is as per the relevant standards.

**9.0.0 Special technical requirement of electrical:-**

- a) One (1) No. Change over type/ isolating switch at Middle of the bay length for each crane.
- b) DSL is to be sized considering maximum length from changeover switch and with a margin of 20% over load requirement. The DSL shall be designed to limit voltage drop at motor terminals within 3% for single length considering the voltage drop in the power cable i.e. from changeover switch to DSL along with voltage drop in DSL. Cable sizes shall be selected accordingly. Suitable guards of MS sheet to live electrical wiring down shop leads shall be provided



**TECHNICAL SPECIFICATION**  
**FOR DOUBLE GIRDER EOT CRANES for Sea water intake**  
**Pump house & BFP ( Up to 50T capacity)**  
 2X660 MW SEZ ENNORE STPP

SPECIFICATION NO. PE-TS-412-501-A101	
VOLUME II - B	SECTION -C
REV. 00	June 2015

**DATA SHEET A (WITH VVVF DRIVES)**

Sl.No	Description	Technical Particulars
1.0	Design, fabrication and testing of the crane confirm to standard / code number	Mechanical and Electrical as per IS: 3177-1999 (Reaffirmed 2006) & Structure design in accordance to IS 807:2006.
2.0	Number of crane/s	Two (2) nos. for BFP & One(1) no. for Sea water intake pump house
3.0	Crane classification	M5 (Mechanical and Electrical)
4.0	Suitable for outdoor or indoor duty	Indoor
5.0	Capacity (T)	25T for Sea water intake pump house & 35T for BFP
5.1	Main hoist	
	Rated SWL – tones	35T for BFP & 25T for Sea water intake pump house
	Test load SWL – tones	(125% of SWL)
5.2	Aux. Hoists	NA
	Rated SWL – tones	NA
	Test load SWL – tones	NA
6.0	Span	As per attached crane clearance diagram
7.0	Operation from	Pendent push button
8.0	CRANE PERFORMANCE	
8.1	Crane speed with full load ( MPM)	
	Main Hoist	1.5
	Aux. Hoist	NA
	Crab travelling speed (CT motion)	15
	Crane travelling speed (LT motion)	30
	Creep speed M/Min	@ 10% of main speed for all the motions through VVVF drive
8.2	Acceleration values	LT motion (bridge travel)      CT motion (trolley travel)



**TECHNICAL SPECIFICATION**  
**FOR DOUBLE GIRDER EOT CRANES for Sea water intake**  
**Pump house & BFP ( Up to 50T capacity)**  
**2X660 MW SEZ ENNORE STPP**

SPECIFICATION NO. PE-TS-412-501-A101  
 VOLUME II - B SECTION -C  
 REV.00 June 2015

		As per IS: 3177	As per IS: 3177
8.3	Lift in Meters		
	Main Hoist	As per Crane clearance diagram	
	Aux Hoist	NA	
8.4	Hook Approaches	As per Crane clearance diagram	
8.5	Hand rail pipes	32 mm NB Medium class of IS: 1239 having top and bottom rail at height of 1050 mm and 600 mm and vertical post spacing not exceeding 1750 mm with provision of kick plate (100 mm high and 6mm thick )	
9.0	COMPONENT DETAILS		
9.1	Trolley		
	Type	Fabricated	
	Method of fabrication	Fusion welded	
	Material conforming to IS:	IS: 2062 Gr. A or B	
	Whether jacking pads for lifting trolley provided or not	Yes	
9.2	Rope drums	Main hoist	Aux. Hoist (NA)
	Material (Indicate IS)	Seamless pipe ASTM -106 or fabricated Fe410w IS: 2062 Gr A/B & stress relieved	
	Numbers provided	One for each hoist	
	Type of grooves	Identical Right hand and Left hand	
	Flange /Flangeless	Flanged	
9.3	Rope details		
	Standard	IS:2266	
	Construction	Extra flexible plough steel / 6 x 36 or 6x37 construction	
	Factor of safety	5.25 as per IS	
	Type of core	Steel	
9.4	Sheaves details	Main hoist	Aux. Hoist (NA)



**TECHNICAL SPECIFICATION**  
**FOR DOUBLE GIRDER EOT CRANES for Sea water intake**  
**Pump house & BFP ( Up to 50T capacity)**  
 2X660 MW SEZ ENNORE STPP

SPECIFICATION NO. PE-TS-412-501-A101	
VOLUME II - B	SECTION -C
REV. 00	June 2015

	Material	Fe 410 WA IS: 2062 Gr. A or B / CS Gr. 280-520 IS: 1030 Design as per IS: 3177- 1999			
	Diameter of Equivalent sheaves in mm on Root	Should not be less than 62% of calculated main sheave diameter.			
	Type of guards provided	Fabricated from rolled steel plate			
9.5	Coupling & Shafting				
9.5.1	Coupling details (between motor and gear box)	Main Hoist	Aux. Hoist (NA)	Cross Travel	Long Travel
	Type	Flexible shock absorbing coupling excepting pin bush type			
	Guards and Enclosures	Provided			
9.5.2	Coupling details (gear box and wheels)	Cross Travel		Long Travel	
	Type	Flexible geared type			
	Guards and Enclosures	Provided			
9.5.3	Coupling details (gear box and rope drum)	Main Hoist		Aux. Hoist (NA)	
	Type	One of the following arrangements will be adopted for connecting the rope drum with the gear- box. 1. Flexible joint, incorporating flexible geared coupling housed within the drum. 2. Fully flexible geared coupling between the drum & gearbox.			
	Guards and Enclosures	Provided			
9.5.4	Shafting (Output)				
	Factor of Safety	As per IS : 3177 (latest edition)			
	Arrangement of Lubrication	Grease cups/ Nipples			
	Type of Lubricant	Grease			
9.6	Gear box details	Fabricated steel gear boxes which shall be dust proof and firmly sealed to prevent oil leakages. Gearboxes shall have covers split horizontally and arranged such that top half can be removed for inspection. The gear boxes shall be fitted with bolted type machined inspection covers.			
A.0	Hoist Motions	MH		MH Micro	



**TECHNICAL SPECIFICATION**  
**FOR DOUBLE GIRDER EOT CRANES for Sea water intake**  
**Pump house & BFP ( Up to 50T capacity)**  
**2X660 MW SEZ ENNORE STPP**

SPECIFICATION NO. PE-TS-412-501-A101  
 VOLUME II - B SECTION -C  
 REV.00 June 2015

	Type of mounting of gear box	Horizontal / Vertical			
	Classification	Suitable for M5 duty			
	Type of gears	Helical / Spur	Through VVVF drive		
	Type of lubrication (grease / splash / pump lubrication)	Splash Lubrication			
	Hardness (BHN) – gear	As Per IS 3177 ( latest edition)			
	Hardness (BHN) – pinion	As Per IS 3177 ( latest edition)			
	Difference in Gear and pinion hardness	Min 20 BHN			
	Material (gear/pinions)	Main Gears En 9/ 55C8/ IS2707 Gr. 1 or 2 Pinions En 19/ EN 24. Hardness conforming to IS: 3177 (latest edition) (All gears shall be suitably heat treated. Gears and pinions shall be hardened ,ground finished, machine cut and profile ground. Gears to be hardened, tempered & heat treated as per IS 4460)			
	Casings	Fabricated Fe 410w IS: 2062 Gr A/B & stress relieved(Fabricated steel gear boxes which shall be dust proof and firmly sealed to prevent oil leakages. Gearboxes shall have covers split horizontally and arranged such that top half can be removed for inspection. The gear boxes shall be fitted with bolted type machined inspection covers).			
	Noise level	85 db		85 db	
B.0	Travel Motions	CT	CT micro	LT	LT micro
	Type of mounting gear box	Vertical / Horizontal	Through VVVF drive	Vertical / Horizontal	Through VVVF drive
	Classification	M5 duty			
	Type of gears	Helical/Spur	Through VVVF drive	Helical/ Spur	Through VVVF drive
	Type of lubrication (grease / splash / pump lubrication)	Splash Lubrication			
	Hardness (BHN) – gear	As Per IS 3177 ( latest edition)			



**TECHNICAL SPECIFICATION**  
**FOR DOUBLE GIRDER EOT CRANES for Sea water intake**  
**Pump house & BFP ( Up to 50T capacity)**  
**2X660 MW SEZ ENNORE STPP**

SPECIFICATION NO. PE-TS-412-501-A101  
 VOLUME II - B SECTION -C  
 REV. 00 June 2015

	Hardness (BHN) – pinion	As Per IS 3177 ( latest edition)	
	Difference in Gear and pinion hardness	Min 20 BHN	
	Materials (gear / pinions)	Main Gears En 9/ 55C8/ IS2707 Gr. 1 or 2 Pinions En 19/ EN 24. Hardness conforming to IS: 3177 (latest edition) All gears shall be suitably heat treated. Gears and pinions shall be hardened ,ground finished, machine cut and profile ground.	
	Casings	Fabricated Fe 410w IS: 2062 Gr A/B & stress relieved (Fabricated steel gear boxes which shall be dust proof and firmly sealed to prevent oil leakages. Gearboxes shall have covers split horizontally and arranged such that top half can be removed for inspection. The gear boxes shall be fitted with bolted type machined inspection covers).	
9.7	Wheels details	Cross travel	Long travel
	Material	forged rolled / cast steel	
	Hardness	300 – 350 BHN	
	Type	Double flanged	
	Specification conforming to	IS: 3177 (latest edition)	
	Arrangement of lubrication	Grease	
9.8	Lifting hooks	MH	AH (NA)
	Type	Plain with safety latch swiveling type as per latest edition of IS: 15560	NA
	Material	➤ Class 1A & 3 for hook of grades L & M respectively as per IS 1875:1992 for hooks conforming to IS : 15560	
	Hook can swivel	Yes	
	Safety latch on hook provided	Yes	
	Locking device on swivelling hook	Provided	
9.9	Buffers	Cross travel	Long travel
	Type	Spring or rubber buffers shall be provided on the trolley & end carriage	
	Numbers provided	4	4
	Details of end stop	Suitable end stops welded to the bridge girder shall be provided to contact the buffers.	



**TECHNICAL SPECIFICATION**  
**FOR DOUBLE GIRDER EOT CRANES for Sea water intake**  
**Pump house & BFP ( Up to 50T capacity)**  
 2X660 MW SEZ ENNORE STPP

SPECIFICATION NO. PE-TS-412-501-A101  
 VOLUME II - B SECTION -C  
 REV. 00 June 2015

10.0	Brakes	All brakes shall have weatherproof enclosures				
A.0	Hoist Motions	MH				
	Type of brake	AC Electro-Hydraulic Thruster operated +DCEM				
	Number	1+1 ( per motor)				
	Braking capacity	150%				
B.0	Travel Motions					
		CT	LT			
	Type of brake	AC Electro-Hydraulic Thruster operated + DCEM	AC Electro-Hydraulic Thruster operated + DCEM			
	Number provided	1+1 ( per motor)	1+1 ( per motor)			
	Braking capacity	125%				
11.0	Drive system for hoisting					
	Arrangement of drive from motor to rope drum (main)	Through geared coupling and gear box				
12.0	Bearings	Crane hook	Trolley wheels	Rope drum	Gear box	Any other assembly
	Type	Antifriction ball / roller bearings				
	Method of lubrication	Grease lubrication				
	Bearing life	10,000 working hours				
13.0	Bridge girder					
	Type & Quantity	Box type – 2 nos. Material: Mild steel, grade A/B of IS 2062 in 100% killed, normalised and ultrasonically tested quality or high strength steel of IS 8500 as appropriate.				
	Vertical Deflection	Span / 900				
	Type of connection to end carriage	By fitted bolts				



**TECHNICAL SPECIFICATION**  
**FOR DOUBLE GIRDER EOT CRANES for Sea water intake**  
**Pump house & BFP ( Up to 50T capacity)**  
 2X660 MW SEZ ENNORE STPP

SPECIFICATION NO. PE-TS-412-501-A101	
VOLUME II - B	SECTION -C
REV. 00	June 2015

14.0	Rails		
	Type / section	Rails sections as per IS: 3443 Grade 55 C 11/ 50 C 12. Rail to rail jointing shall be by end clamping arrangement.	
	Standard conforming to	IS: 3443	
	Material	50C12 or 55C11	
15.0	End carriage span material	Structural steel.	
16.0	Motors	Suitable for ambient temperature of 50 <sup>0</sup> C	
16.1	Hoist Motions	MH	MH micro
	Type	SC, suitable for Inverter duty Three phase squirrel cage induction motors operated from VFD system and suitable for speed range and torque without exceeding temperature rise limits.	Through VVVF drive
	Enclosure	TEFC	
	Numbers furnished	1	
	Voltage, phase and frequency	3 Ph., 4 wire, 415V ± 10%, 50 Hz ± 5% Combined voltage & frequency variation = 10% absolute	
	Class of protection	IP – 55	
	Rated capacity (KW)	Motor nameplate rating at 50 <sup>0</sup> C shall have Motor rating will be calculated keeping margin of at least 25% over the maximum power requirement in the duty condition specified. Further, the hoist motors will be rated to lift 125% of the design load on the hook at the rated speed.	
	Rating	S4, 40 % CDF	
	Class of insulation	Class 'F' for sq. cage motors with temp rise limited to that of class B	
	Number of starts/ hour	300 starts / hr	
	Pull out torque	The pull out torque of the motor will not be less than 275 % of the full load torque.	
	Overload protection for motors provided	In built feature of VVVF drives.	
	Space heater requirements	For motors of rating 30 KW and above	



**TECHNICAL SPECIFICATION**  
**FOR DOUBLE GIRDER EOT CRANES for Sea water intake**  
**Pump house & BFP ( Up to 50T capacity)**  
 2X660 MW SEZ ENNORE STPP

SPECIFICATION NO. PE-TS-412-501-A101  
 VOLUME II - B SECTION -C  
 REV. 00 June 2015

16.2	Travel Motions	CT	CT micro	LT	LT micro
	Type	SC, suitable for Inverter duty Three phase squirrel cage induction motors operated from VFD system and suitable for speed range and torque without exceeding temperature rise limits.	Through VVVF drive	SC, suitable for Inverter duty Three phase squirrel cage induction motors operated from VFD system and suitable for speed range and torque without exceeding temperature rise limits.	Through VVVF drive
	Enclosure	TEFC	Through VVVF drive	TEFC	Through VVVF drive
	Numbers furnished	1 no.	Through VVVF drive	2 nos.	Through VVVF drive
	Voltage, phase and frequency	3 Ph, 4 wire, 415V $\pm$ 10%, 50 Hz $\pm$ 5% Combined voltage & frequency variation = 10% absolute			
	Class of protection	IP – 55			
	Rated capacity (KW)	Motor nameplate rating at 50° C shall have Motor rating will be calculated keeping margin of at least 25% over the maximum power requirement in the duty condition specified.			
	Rating	S4, 40 % CDF			
	Class of insulation	Class 'F' for sq. cage motors with temperature rise limited to that of class B			
	Number of starts/ hour	300 starts / hr			
	Space heater requirement	For motors above 30 KW rating			
	Pull out torque	The pull out torque of the motor will not be less than 275 % of the full load torque.			
	Overload protection for motors provided	In built feature of VVVF drives.			
	Space heater requirements	For motors of rating 30 KW and above			



**TECHNICAL SPECIFICATION**  
**FOR DOUBLE GIRDER EOT CRANES for Sea water intake**  
**Pump house & BFP ( Up to 50T capacity)**  
 2X660 MW SEZ ENNORE STPP

SPECIFICATION NO. PE-TS-412-501-A101  
 VOLUME II - B SECTION -C  
 REV.00 June 2015

17.0	<u>Limit switches</u>	Main hoist	Aux. Hoist (NA)	Cross Travel	Long Travel
	Type	Rotary gear (screw type) + Gravity	NA	Lever type (one way/ two way)	Lever type (one way/ two way)
	Number provided	1 + 1	NA	2/1	2/1
	Control voltage/ Enclosure	110 V/ IP 55			
18.0	<u>Power conductors (DSL)</u>				
	Type	LT: PVC shrouded conductor ( Cu) bus bar. CT: Flexible trailing cable ERP insulated Cu conductor as per IS: 9968			
19.0	Length	Suitable for entire bay length			
	Protective Panel	Shall be provided with isolating switch, power contactor control and indication to switch ON/OFF power to starter panels, control and lighting transformer.			
	Material & size	Cold Rolled sheet steel , not less than 2.5mm for front & rear & 2mm for side, top & bottom portion with gland plate of 3mm thick			
	DOP	IP 54			
20.0	<u>Control panel</u>	Separate VVVF system panels to be provided for CT, LT and both hoist motions			
	Material	Sheet steel 2 mm size			
	Numbers and location	One each for MH, AH, CT and LT located on bridge platform			
	Degree of Protection	IP 54			
	Illumination	Internal illumination with florescent lamp			
21.0	Earthing	Crane structures, motor frames and metal cases of all electrical equipment including metal conduit and cable guards shall be effectively earthed.			
	Material of earthing	G.I / Copper			
22.0	<u>Cable</u>	Power (fixed type cable)		Control	
	Material	Aluminium		Copper	
	Size	Min. 3Cx10 mm <sup>2</sup> for Aluminium		Min. 1.5 mm <sup>2</sup>	
	Type	XLPE insulated (except trailing cable)		PVC insulated	



**TECHNICAL SPECIFICATION**  
**FOR DOUBLE GIRDER EOT CRANES for Sea water intake**  
**Pump house & BFP ( Up to 50T capacity)**  
 2X660 MW SEZ ENNORE STPP

SPECIFICATION NO. PE-TS-412-501-A101	
VOLUME II - B	SECTION -C
REV. 00	June 2015

	Voltage grade	1100 V
	Voltage drop	Cable from main isolating switch (1.5M above operating floor) to motor terminal shall be so sized that the voltage drop does not exceed 3% of rated voltage.
23.0	Contactors	AC 4 duty for reversing application. AC 3 duty for non-reversing application.
24.0	Switches	AC 23 for motor application, AC 22 for other application.
25.0	Fuses	HRC
26.0	Overload relays	Overload protection inbuilt in VVVF drives.
27.0	Fire Extinguisher	
	Type and size	4.5 kg , CO <sub>2</sub> type
	Numbers & Location	Two on bridge
28.0	Power Supply	415 V, 3 phase, 4 wire supply at operating floor at centre of bay length.
29.0	Transformer	Dry type, with insulation class B or better.
	Quantity	2 X 100 % for control, 2 nos for lighting & 1 no for hand lamp.
	Voltage Rating	Control 415/240V , Lighting 415/240V and hand lamp 415/24V.
	KVA rating	20% over loading to be considered while sizing the rating
30.0	Illumination	
	Over Bridge	2 nos. 60 W Bulk-head fittings with incandescent lambs and 4 nos. 24V – 5A – 3 pin industrial socket
	Under bridge	2 nos. 250 W HBSV lamps
	For inspection of crane components	One (1) portable 40W hand lamp with min. half span length flexible cable for inspection of crane components
	Hand lamp socket and hand tool sockets	Hand lamp socket outlets (2 pin, 10A, 24V) and power socket outlets (3 pin, 20A, 240V) shall be provided for use of hand tools along with switches.
31.0	Type of platform required on the bridge.	Chequered plate platform 6 mm thick as per IS :3502
	Length	Full span length
	Type of access from gantry girder level to crane bridge	Rung ladder at ends from gantry girder level walkway to crane bridges walkway

	<b>TECHNICAL SPECIFICATION</b>	SPECIFICATION NO. PE-TS-412-501-A101	
	<b>FOR DOUBLE GIRDER EOT CRANES for Sea water intake</b>	VOLUME II - B	SECTION -C
	<b><u>Pump house &amp; BFP ( Up to 50T capacity)</u></b>		
	<b>2X660 MW SEZ ENNORE STPP</b>	REV. 00	June 2015

	Type of access to maintenance cage from crane bridges walkway	Rung ladder
	Type of access to Cabin from crane bridges walkway	By Staircase
	Provided at both ends	Yes
	Width of platform	Access walkway of not less than 500mm clear with hand railing of height of 1100mm along both sides of bridge girder and cross over walkways.
32.0	Type of control for Hoists/ CT/LT operation	Through VVVF drive
	Speed control	Thru' VVVF with minimum 6 pulse design
	Starting torque of VVVF	Up to 400% typical with encoder.
	Starting current	Less than 150 % of rated torque.
	Temperature	VVVF system shall be capable of withstanding upto 50 o C without derating.
33.0	Sweep	Sweep shall be attached to the end carriages and to the trolley to remove foreign materials from the rails.
34.0	Painting & Color Coding	As per Painting specification enclosed.
35.0	Main Isolating switch / Change over type	Main isolating switch / change over type at Middle of the bay length

NOTE : Other requirements of the system-

- All Crane motors shall be capable of the following :
  - Operating satisfactorily at full load for 5 minutes without injurious heating with 75% rated voltage at motor terminals.
  - Withstand 120% of rated speed for two minutes.
  - Current shall not exceed 6 times full load current for creep speed motor.
  - Withstanding the stresses imposed if started at 110% rated voltage.
  - Start with rated load and accelerate to full speed with 80% rated voltage at motor terminals.
  - The locked rotor motor withstand time under hot condition at 110% rated voltage shall be more than motor starting time at minimum permissible voltage by at least 3 seconds for motors upto 20 seconds starting time.
  - Maximum torque shall not be below 200% of full load torque.
- The VVf drive control shall be used for control of each motion. The VVf drive shall be equipped at least with 1024 pulse incard, droop control for synchronization and crane software. The rating of VVF

	<b>TECHNICAL SPECIFICATION</b>	SPECIFICATION NO. PE-TS-412-501-A101	
	<b><u>FOR DOUBLE GIRDER EOT CRANES for Sea water intake</u></b>	VOLUME II - B	SECTION -C
	<b><u>Pump house &amp; BFP ( Up to 50T capacity)</u></b>		
	2X660 MW SEZ ENNORE STPP	REV.00	June 2015

shall be decided considering 250% of full load current of respective drive motor based on in panel rating with derated at 50 Deg C ambient temperature.

- The limit switches shall be totally enclosed type IP-55.
  - Each hoist shall be furnished with two (2) limit switches meeting the following requirements:
    - A screw type limit switch with self resetting features which will act in case of over hoisting.
    - A gravity operated hand reset type limit switch as a back up protection against over hoisting.
- Trailing cable shall be 1100 V grade, tinned copper, heat resistant, with EPR insulation and as per Class – 5 of IS-8130. Also should have inner PCP sheath and outer CSP sheath with nylon chord reinforcement & heat resistant, oil resistant and flame retardant heavy duty FRLS type.
- Electrical equipment shall be adequately rated to permit simultaneous operation of the combination of motions of the crane for it duty service.
- Provision of operation of Hydraulic rail clamp operable from operator's cabin shall also be provided.
- Track type limit switches on the bridge and trolley to prevent over travelling in either direction



MANUFACTURER'S NAME & ADDRESS		MANUFACTURING QUALITY PLAN (FOR REFERENCE)										
		ITEM:		QP NO :	PE-TS-412-501-A101	AGENCY	PROJECT : 2x660 MW SEZ ENNORE STPP			PACKAGE : DOUBLE GIRDER CRANES		
		CLASS	CHARACTERISTICS	TYPE PF CHECK	QUANTUM OF CHECK	REFERENCE DOCUMENT	ACCEPTANCE NORMS	FORMAT OF RECORDS	M	C	N	REMARKS
1	COMPONENTS & OPERATION	4	3	5	6	7	8	9	D*	10	11	Refer note: 2
					compression 100% in rope drum			RT film				
		Critical		DPT	100%	IS: 3658	ASME Sec-VII,	Vendor insp	P	W	V	DP test of filletweld for ropedrum to be conducted after final machining
							Appen - 8	Report				Random witness by BHEL
d	fillet welds	Major	Size and surface defects	Visual	100%	Component Drg.	Component Drg.	Vender insp. Report	P	V	V	
e	final insecton of fabricated components listed in Sr.1 above	Major	Dimensions for Girder, end carriage rope drum etc. Camber, Verticality, bend etc	DPT	10% RANDOM	ASME Sec VIII-Div1-Append 8	ASME Sec VIII-Div1-Append 8	Vender insp. Report	V	P	W	V
f	Heat treatment of rope drum	Major	Stress relieving	Review of SR chart	100%	ASME Sec-VIII, Div - I	ASME Sec-VIII, Div - I	Vendor Mfg. Drg. SR Chart	V	P	V	V
3	Gear box casing											
a	Material	Major	Surface condition	Visual	100%	Component Drg.	Component Drg.	Vendor insp Report	P	V	V	Refer note 1
		Major	Chemical & mech	Measurement	100%	Component Drg.	Component Drg.	T.C. & I.R.	V	P	V	V
				Correlation with T.C. Check test in absence of T.C.	100%	IS:2062	IS:2062					
				Correlation								



MANUFACTURER'S NAME & ADDRESS		MANUFACTURING QUALITY PLAN (FOR REFERENCE)										PROJECT : 2x660 MW SEZ ENNORE STPP PACKAGE : DOUBLE GIRDER CRANES	
		ITEM:		QP NO : PE-TS-412-501-A101	CONTRACT NO :	AGENCY		REMARKS		M C N			
		REV : 0	DATE :	REFERENCE DOCUMENT	NORMS	FORMAT OF RECORDS	D* 10						
		QUANTUM OF CHECK	TYPE PF CHECK	REFERENCE DOCUMENT	NORMS	FORMAT OF RECORDS	D* 10						
		100%	5	Mfg.drg./IS:1570	Mfg.drg./IS:1570	Test	9					11	
		100%	Corelation with mfr's TC	/ BS - 970	/ BS - 970	Certificate						Refer Note:1	
		100%	Measurement	Component Drawing	Component Drawing	Vendor insp.							
		100%	Mechanical	Approved Data Sheet / Mfg. Drg.	Approved Data Sheet / Mfg. Drg.	Report							
		100%	NDT	ASTM A 388	ASTM A 388							Refer UT procedure	
		100%	NDT	ASME Sec-VIII-App-8	ASME Sec-VIII-App-8								
		100%	Correlation with mfr's TC	Component Drawing	Component Drawing	Vendor insp.							
		100%	Check test in absence of TC	Approved Data Sheet	Approved Data Sheet								
		100%	Major	ASME Sec-V	Refer UT procedure	Vendor insp.						Hardness witnessing by BHEL before teeth cutting.	
		100%	Major	Mfg. drg. & check for (above 50mm dia)	Mfg. drg. & check for	Report							
		100%	Major	Hardness	Mfg. drg. & Approved Data	Vendor insp.							
		100%	Major	Measurement	Component Drawing	Report							
		100%	Major	NDT	ASTME-165	Report							
		100%	Major	NDT	No Crack and line of indication	Vendor insp.							
		100%	Major	Corelation with mfr's TC	Components Drawing	Report							
		100%	Major	Measurement	Components Drawing	Mfr's T.C.							
		100%	Major	NDT	ASTM E-165	Vendor insp. report							
		100%	Major	NDT	No. crack / Liner indication	Vendor insp. Report							
B		Pulleys, Brake drums, coupling & other major steel castings & forging											
i) Materials		Physical/Chemical/Hardness		Major		Corelation with mfr's TC		Components Drawing		Mfr's T.C.		P V V	
ii) Machined		a) Dimensions		Major		Measurement		Components Drawing		Vendor insp		P V V	
		b) DPT after machining.		Major		NDT		ASTM E-165		Vendor insp. Report		P V V	

MANUFACTURER'S NAME & ADDRESS		MANUFACTURING QUALITY PLAN (FOR REFERENCE)										PROJECT : 2x680 MW SEZ ENNORE STPP					
		ITEM:										PACKAGE : DOUBLE GIRDER CRANES					
		CLASS		TYPE PF CHECK		QUANTUM OF CHECK		REFERENCE DOCUMENT		ACCEPTANCE NORMS		FORMAT OF RECORDS		AGENCY		REMARKS	
COMPONENTS & OPERATION		CHARACTERISTICS		CHECK		OF CHECK		DOCUMENT		NORMS		RECORDS		M C N			
1	C	Gear box assy & idle running	3	4	5	6	7	8	9	10	11						
			Check for oil leakage, Noise level, vibration backlash, rise in temp. after 2 Hrs. of running. reduction ration, backlash and contact pattern	Major	Visual & Measurement	100%	Vendor standard	Smooth running no oil leakage, Noise 85 db at 1 Mtr. Max. Temp. rise 40°C above amb	Vendor insp. Report	Vendor insp.	Vendor insp.	P	V	V			
			dimensional conformity	Major	Measurement	100%	Assembly drawing	Assembly drawing	Vendor insp.	Vendor insp.	Vendor insp.	P	V	V			
			i) Chemical composition, Heat treatment, Mechanical properties on integral test bar	Major	Chemical, heat treatment & Tensile, % elongation	100%	IS:1875	IS:1875	Test Certificate, HT chart & Insp. Report	Test Certificate, HT chart & Insp. Report	Test Certificate, HT chart & Insp. Report	P	V	V			
			ii) UT on raw material of hook	Major	UT	100%	ASME sec-v	Annex-1 (Attached)	Report	Report	Report	P	V	V			
			iii) Forging operation of hook	Major	Visual	100%	IS:5749 / IS:15560	IS:5749 / IS:15560				P	V	V			
			iv) Proof load test	Major	Mechanical	100%	IS:5749 / IS:15560	IS:5749 / IS:15560				P	V	V			
			v) UT & MPI after proof load test	Major	UT & MPI	100%	ASME sec - v	Annex-1 for UT & MPI				P	V	V			
								No crack & linear indication (For MPI)									
			Diemnsional conformity	Major	Measurement	100%	Component Drawing	Tolerance as per drg	Vendor insp	Vendor insp	Vendor insp	P	V	V			
									Report	Report	Report						
11	a)	Electrical components Motors ( =< 50 KW)	make , type , rating, Routine test	Major	Review mfr's TC	100%	IS:325	IS 325/Mfr's T.C.	Mfr's T.C.	Mfr's T.C.	Mfr's T.C.	P	V	V			Refer Note 3. For Motor above 50kW separate QP shall be followed
	b)	Brakes	Make , t ype , rating , dia , IR, HV , Functional test /Routine test	Major	Review mfr's TC	100%	Appd drgs	Appd drgs	Mfr's T.C.	Mfr's T.C.	Mfr's T.C.	P	V	V			

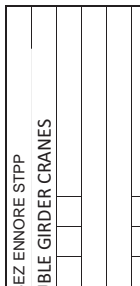

MANUFACTURER'S NAME & ADDRESS

PROJECT : 2x660 MW SEZ ENNORE STPP  
 PACKAGE : DOUBLE GIRDER CRANES  
 CONTRACT NO :  
 CONTRACTOR :  
 VENDOR'S QAP No.:

**MANUFACTURING QUALITY PLAN (FOR REFERENCE)**

ITEM:  
 QP NO : PE-TS-412-501-A101  
 REV : 0  
 DATE :

SL. NO.	COMPONENTS & OPERATION	CHARACTERISTICS	CLASS	TYPE PF CHECK	QUANTUM OF CHECK	REFERENCE DOCUMENT	ACCEPTANCE		FORMAT OF RECORDS	AGENCY			REMARKS
							NORMS			M	C	N	
1	4	3	4	5	6	7	8	9	D**	10		11	
c)	Control panel	Interlocking functional, IR, HV, Sheet thickness, cable laying, dressing, ferulling Overall diemnsions , painting shade, Panel surface finish, Thickness, adhesive test, Component fixing. Degree of protection by paper inserting method	CR	Test for HV functional & routine check	100%	Relevant drg & Generally confirm to IS : 3177 / App. Panel Drg. & BOM	Relevant drg. & IS : 3177 / App. Panel Drg. & BOM	Vendrs insp Report	V	P	W	V	Refer Note No. 4
d)	Pendent , switches	HV, IR,Functional	Major	Verification	100%	BOM/ Mfr. Catalogue	BOM/ Mfr. Catalogue	Mfr's T.C.	V	P	V	V	Refer Note No. 4
e)	Limit switches	HV, IR & Functional	Major	Verification	100%	Approved drawings	Approved drawings	Mfr's T.C.	V	P	V	V	
f)	Trailing cable, Power	Make , type , rating ,Routine & acceptance test	Major	Verification	100%	IS: 9968	IS: 9968	Mfr's T.C.	V	P	V	V	
g)	Control Cable & DSL	insulation resistance values	Major	visual	100%	IS 1554-Part-1	IS 1554-Part-1	IR					
h)	Transformer SFU, MCCB, MCB, Contactors, DSL, relays, fuses, resistance bank	make rating, routine test make, t ype , rating size, functional, continuity check	Major	visual	100%	Appd drg	Appd drg	IR					
i)	VVVF drives	make , type , rating, routine test	Major	visual	100%	Appd drg	Appd drg	IR					
j)	cable gland , ,lugs ,r ectifier, indicating lamps, terminal blocks	make , type	Major	visual	100%	Appd drg	Appd drg	IR					
12	Bought our items												
a)	Wire rope	Visual , tensile	Major	Type, grade, dia breaking strength	100%	IS:2266	IS:2266	T.C.	V	P	V	V	
b)	Other items	Dimensional conformity	Major	Review TC	100%	Relevant Drg.	Relevant Drg.	Vendor					
c)	Bearing	Type & Size	Major	Verification		Appd drg/Mfr's catalogue	Appd drg/Mfr's catalogue	Confirmation	V	P	V	V	

MANUFACTURER'S NAME & ADDRESS		MANUFACTURING QUALITY PLAN (FOR REFERENCE)									
		PROJECT : 2x660 MW SEZ ENNORE STPP		PACKAGE : DOUBLE GIRDER CRANES		CONTRACT NO :		CONTRACTOR :		VENDOR'S QAP No :	
		ITEM:		QAP NO : PE-TS-412-501-A101		REV : 0		DATE : 1			
SL. NO.	COMPONENTS & OPERATION	CHARACTERISTICS	CLASS	TYPE PF CHECK	QUANTUM OF CHECK	REFERENCE DOCUMENT	ACCEPTANCE NORMS	FORMAT OF RECORDS	AGENCY	REMARKS	
1	Assembly of cranes	3	4	5	6	7	8	9	D** 10	11	
13	Bridge with LT		Major	Measurement	100%	GA drg/IS:3177	GA drg/IS:3177	Vendor insp. report	V P W V		
a)	Crab assembly	Dimesions, wheel level alignment	Major	Measurement/Visual	100%	GA drg/IS:3177	GA drg/IS:3177	Vendor insp. report	V P W V		
b)	Final Inspection (at works)	Overall dimension: Span, Diagonal dimension	Major	Measurement	100%	Approved drgs./IS:3177	Approved drgs./IS:3177	Vendor insp. report	V P W W		
c)	with actual panel and pendent	check, headroom, lift, Eqp. Layout on bridge platform, No Load running of LT machinery									
		<b>No Load &amp; Load Tests</b>									
		a) No load: Hoists,CT,LT speed & current measurement..	Major	Measurement	100%	Approved drgs	Approved drgs	Vendor insp. report	V P W W		
		b) SWL: Hoists, CT speed, current & Deflection measurement	Major		100%	GA drg/IS:3177	GA drg/IS:3177	Vendor crane test report	P W W		
		c) Overload: Hoisting, CT movement & current measurement (at 125% SWL)	Major	Operational		Tech. Specification	Tech. Specification	report			
		d) Operation check of brakes and limit switches.		Check		Tech. Specification	Tech. Specification	report			
15	Review of QA documentation						As per approved QAP		V V V		
16	Cleaning and Painting	Surface preparation & Painting	Major	Visual		Approved drgs/doc	Approved drgs/doc	Vendor's Report	P V		
		<p>Note 1 : Original TCs / Photocopies certified in original by mill shall be furnished for review. Test in absence of correlated TCs Check test shall be carried out from each plate/ bar for above 10 mm thk., certificates shall be offered for review at the time of stage inspection of components / assembly. Supplier shall ensure that pitted material is not used.</p>									
		<p>Note 2 : X-Ray to be taken for thickness upto 19 mm and Gamma Ray for thickness above 19 mm. If Gamma Ray is used for lower thickness slow speed film like D2 or equivalent which gives enough readable and interpretable film quality to be used for clarity. All NDT shall be carried out by Qualified Level II personnel.</p>									

MANUFACTURER'S NAME & ADDRESS		MANUFACTURING QUALITY PLAN (FOR REFERENCE)															
		PROJECT : 2x660 MW SEZ ENNORE STPP		PACKAGE : DOUBLE GIRDER CRANES		CONTRACT NO :		CONTRACTOR :		VENDOR'S QAP No :							
		ITEM:		QP NO : PE-TS-412-501-A101		REV : 0		DATE :									
COMPONENTS & OPERATION		CLASS		TYPE PF CHECK		QUANTUM OF CHECK		REFERENCE DOCUMENT		ACCEPTANCE NORMS		FORMAT OF RECORDS		AGENCY		REMARKS	
4		4		5		6		7		8		9		M C N		11	
1		3												D** 10			
Note 3 :		<p>LESS THAN 30KW: ACCEPTANCE OF MOTOR LESS THAN 30 KW IS BASED ON COC OF THE MANUFACTURER &amp; THE CONTRACTOR CONFIRMING AS FOLLOWS: IT IS HEREBY CONFIRMED THAT THE ABOVE MENTIONED MOTOR /MOTORS WAS/ WERE MANUFACTURED TAKING CARE OF CUSTOMER SPECIFIC REQUIREMENTS REGARDING AMBIENT TEMP., VOLTAGE &amp; FREQUENCY VARIATION, HOT STARTS, PULL OUT TORQUE, STARTING KVA/KW, TEMP. RISE, DISTANCE BETWEEN CENTRE OF STUD &amp; GLAND PLATE AND TESTED IN ACCORDANCE WITH APPROVED DRAWING /DATA SHEETS.</p>															
		<p>30 KW to 50KW : ACCEPTANCE OF MOTOR RATING BETWEEN 30 KW &amp; 50 KW IS BASED ON CUSTOMER REVIEW OF ROUTINE TEST INSPECTION REPORT AS PER IS 325 ALONG WITH COC OF THE MANUFACTURER &amp; THE CONTRACTOR CONFIRMING AS FOLLOWS: IT IS HEREBY CONFIRMED THAT THE ABOVE MENTIONED MOTOR /MOTORS WAS/ WERE MANUFACTURED TAKING CARE OF CUSTOMER SPECIFIC REQUIREMENTS REGARDING AMBIENT TEMP., VOLTAGE &amp; FREQUENCY VARIATION, HOT STARTS, PULL OUT TORQUE, STARTING KVA/KW, TEMP. RISE, DISTANCE BETWEEN CENTRE OF STUD &amp; GLAND PLATE, SPACE HEATER AND TESTED IN ACCORDANCE WITH APPROVED DRAWING /DATA SHEETS.</p>															
Note 4 :		Performance of electrical & control devices along with the interlocks, protection & sequence to be checked during crane assembly and parked at works.															
Note 5 :		All material of construction shall be as per approved drg. / data sheet / specifications															
		<p><b>LEGEND :</b></p> <p>D * RECORDS IDENTIFIED WITH 'TICK'( ✓ ) SHALL BE ESSENTIALLY INCLUDED BY CONTRACTOR IN QA DOCUMENTATION</p> <p>** M : MANUFACTURER/SUBCONTRACTOR</p> <p>C: BHEL-COS/THIRD PARTY INDICATE "P" PERFORM "W" WITNESS AND "V" DOCUMENT REVIEW</p> <p>N : CUSTOMER</p>															
MANUFACTURER/		CONTRACTOR															
SUBCONTRACTOR		SIGNATURE															
		REVIEWED BY															
		NAME & SIGN OF APPROVING AUTHORITY & SEAL															

### ULTRASONIC TEST PROCEDURE

1. Specification Applicable : **(I) ASTM A – 388**
2. Test Purpose : This test conducted on Round Bar, Forging Blank & Hook material (Before Forming) to detect Internal Defect.
3. Condition of material : As rolled/ Normalized Surface shall be prepared as Necessary for conducting the ultrasonic test.
4. Method : Contact method using with pulse-back echo.
5. Equipment details : Modsonic Instrument/ EEC- PX-10
6. Scanning Area : Scanning shall be done in 100% area direction all Along the length and width scanning shall be done at  $\pm 6$  db. Evaluation shall be done at reference level.
7. Couplant : Oil/Water
8. Calibration block : The ultrasonic flow detector shall be calibrated by Using standard calibration block IIW V1, V2.
9. Probe used : Probe dia 24mm, 2MHz, 4MHz (NB)  
Probe dia 10mm x 4MHz, 24 mm Dia x 2MHz (NB)  
(For Hook)
10. Calibration : By choosing proper depth range and gain, the back Wall echo from a defect free area shall be brought To 100 % full screen height (FSH). This shall be The reference level.
11. Acceptance Norms : Loss of back echo: More than 20% not acceptable.  
Defect echo more than 20% not acceptable.  
Any indication characterized as cracks, lamination, Or any linear defect is not acceptable.
12. Personnel Qualification : The ultrasonic test shall be carried out and results are Evaluated by a person qualified to ISNT/ASNT LEVEL-II.

	Technical specification for Double girder EOT cranes for BFP, Sea water Intake pump house ( Up to 50T Cap.) 2x660 MW SEZ ENNORE STPP	Spec no:- PE-TS-412-501-A101
		<b>VOLUME II B</b>
		<b>SECTION-C</b>
		<b>Page 1 of 7</b>

## PAINTING

### 1.0 SCOPE

This section defines the technical requirements for surface preparation, selection and application of paints on cranes structures, its mechanical components , motors & panels etc. The bidder shall submit a detailed painting procedure for approval of owner/ owner's representative after the award of contract.

### 2.0 CODES AND STANDARDS

Painting of equipment shall be carried out as per the specifications indicated below and shall conform to the relevant IS specification for the material and workmanship.

The following Indian Standards may be referred to for carrying out the painting job :

IS:5 : Colours for ready mixed paints and enamels

IS:1303 : Glossary of terms relating to paints

IS:2379 : Colour code for identification of pipelines

IS:1477 : Code of practice for painting of ferrous metals in buildings (Parts I & II)

IS:2524 : Code of practice for painting of non-ferrous metals in buildings (Parts I & II)

**IS:2395 : Code of practice for painting of concrete, masonry and plaster surfaces (Parts I & II)**

IS:2338 : Code of practice for finishing of wood and wood based materials (Parts I & II)

IS:158 : Ready mixed paint, brushing, bituminous, black, lead free, acid, alkali, water and heat resisting.

IS:2074 : Ready mixed paint, air drying, red Oxide Zinc Chrome, priming

IS:104 : Ready mixed paint, brushing, Zinc Chrome, priming

IS:2932 : Enamel Synthetic exterior

(a) Undercoating

(b) finishing

IS:4682 : Code of practice for lining of vessels & equipment

SIS 559000 : Swedish standard for blasting

ISO 8504-2 : Preparation of steel substrates before application of paints and related products. Surface preparation methods Part 2 Abrasive blast cleaning

	Technical specification for Double girder EOT cranes for BFP, Sea water Intake pump house ( Up to 50T Cap.) 2x660 MW SEZ ENNORE STPP	Spec no:- PE-TS-412-501-A101
		<b>VOLUME II B</b>
		<b>SECTION-C</b>
		<b>Page 2 of 7</b>

ISO 8501-1 : Preparation of steel substrates before application of paints and related products. Visual assessment of surface cleanliness. Part 1 : Rust grades and preparation grades of uncoated steel substrates and of steel substrates after overall removal of previous coatings.

SIS 05 5800 : Surface preparation by acid pickling

SSPC SP08 : Surface preparation by acid pickling

IS 2629 : Recommended practice for hot dip galvanizing of iron and steel

ASTM A780 : Standard practice for repair of damaged galvanized coatings

SSPC : Steel structures painting council

NACE : National association of Corrosion Engineers

DIN : Deutsche Institute for Normung

BS : British Standard

ASTM : American Society for Testing material

AWWA : American Water works association

### 3.0 SURFACE PREPARATION

The surface shall be prepared in a manner suitable for coatings. Chemical derusters or rust converters shall not be applied. Acid cleaning is subject to approval of Purchaser/ Purchaser's representative.

#### 3.1 BLASTING

The surface of the part/ component shall be blasted before the coating material is applied. Compressed air supply for blast cleaning shall be free of water and oil. Air compressors shall not be allowed to deliver air above 1100C. Blasting activity shall be performed at temperatures 30C above dew point and substrate temperature between 50C & 500C and relative humidity not exceeding 85% shall be maintained during painting. Necessary safety precautions for equipment and operator shall be adhered to and shall comply with applicable laws, regulations, ordinances etc., of the local authority, state or the nation pertains to the work. Abrasive used for blast cleaning carbon steel and alloy steel shall be as per ISO 8504-2 and SSPC painting manual. Suggested abrasives are chilled iron grit, shot steel, malleable iron grit and shots of non metallic abrasive (aluminum oxide, copper slag, garnet etc.).

The grade of blasting shall be performed in line with the approved painting scheme.

The nature, quality and grain size of abrasives and the parameter of their use are to be chosen to obtain the required surface profile depth and cleanliness.

	Technical specification for Double girder EOT cranes for BFP, Sea water Intake pump house ( Up to 50T Cap.) 2x660 MW SEZ ENNORE STPP	Spec no:- PE-TS-412-501-A101
		<b>VOLUME II B</b>
		<b>SECTION-C</b>
		<b>Page 3 of 7</b>

Surfaces prepared for coating shall be coated the same day and before any visible rusting occurs (the time elapsed between blast cleaning and commencement of painting shall under no circumstances exceed 4 hours, but in any case must commence before signs of degradation occur).

### The grades of surface finish:-

Unless otherwise specified in the documents, the surface shall satisfy the following requirements after blasting (a) Blasting according to SIS 055900, Grade Sa 2½.

Primer paint shall be Zinc Silicate of approved brand. Dry film thickness of each primer coat shall be 60 µm.

#### 3.2 Manual Rust Removal

Manual rust removal shall be allowed for welded zones and for touching up installed components.

#### 3.3 Cleaning Removal

- |                                  |  |
|----------------------------------|--|
| a) Dust, loose deposits          | Vacuum-cleaning, brushing  |
| c) Adhesive deposits             | Power brushing   |
| d) Oils, greasy impurities       | Wet blasting, use of detergent additives by agreement  |
| e) Salt deposits                 | Rinsing  |
| f) Markings (e.g., felt tip pen) | Organic solvents to manufacturer's specifications eg<br>Trichloro trifluoro ethane and solvents containing acetone<br>(renew solvent and rag frequently) |

### 4.1 General

#### Application Conditions

The primer shall be applied to properly prepared surfaces only. The specifications of the coating material manufacturers shall be observed. The minimum temperature shall be + 5°C and the relative humidity shall not exceed 80%. The temperature of the work piece shall be at least 3°C above dew point.

#### 4.2 Application Procedure

The primer shall be applied by means of brush or by spray. The top coats shall be applied by means of brush, roller or spray.

At points where coating application is interrupted, the individual layers shall be adequately stepped to ensure proper layer sequence when coating operations are resumed.

	Technical specification for Double girder EOT cranes for BFP, Sea water Intake pump house ( Up to 50T Cap.) 2x660 MW SEZ ENNORE STPP	Spec no:- PE-TS-412-501-A101
		<b>VOLUME II B</b>
		<b>SECTION-C</b>
		<b>Page 4 of 7</b>

### 4.3 Touching Up

Before each layer is applied, previous coating shall be touched up where necessary by way of rust removal and cleaning according coating manufacturers specification. The final top shall be reapplies completely.

### 4.4 Uncoated Surfaces

Moving parts of machines (e.g stems, shafts, sliding and locating bearings), nameplates, instruments and sealing surface shall not be coated. Welds shall be left free of coating upto a distance of 30 mm on each side of the weld edge until erection and weld examinations, if any, have been completed.

### 4.5 Bond Strength

The pill off stress determined using the pull off test method for adhesion shall not be less than 1.5 N/mm<sup>2</sup>, according to ISO 4624.

### 5.0 Painting System :-

#### (a) Crane Steel Surfaces /structures

(i) All steel structures shall receive two primer coats and two sandwich coat of MIO Epoxy paint and one finish coat of painting. First coat of primer shall be given in shop after fabrication before dispatch to erection site after surface preparation as described below. The second coat of primer shall be applied after erection and final alignment of the erected structures. Two intermediate coats and one finished coat shall also be applied after erection.

(ii) Steel surface which is to be painted shall be cleaned of dust and grease and the heavier layers of rust shall be removed by chipping prior to actual surface preparation. The surface shall be abrasive blasted as explained in clause 3.1 to Sa 2½ finish as per SIS05-5900. Primer paint shall be Zinc Silicate of approved brand. Dry film thickness of each primer shall be 60 microns. Total primer thickness of two coats total thickness 120 microns.

(iii) Two intermediate MIO Epoxy paint, and one top polyurethane coating of approved brand shall be applied. Dry film thickness of each intermediate coat shall be 90 microns, total intermediate coatings thickness shall be 180 Microns. and top polyurethane coating/finish shall be 30 microns. The under coat and finish coat shall be of different tint to distinguish the same from finish paint. The total dry film thickness shall be 330 microns. All paints shall be of approved brand and shade as per owner's requirement.

(iv) Joints to be site welded shall have weldable primer applied within 100 mm of welding zone. Similarly where friction grip fasteners are to be used removable anti corrosive coating shall be provided. On completion of the joint the surfaces shall receive the paint as specified.

	Technical specification for Double girder EOT cranes for BFP, Sea water Intake pump house ( Up to 50T Cap.) 2x660 MW SEZ ENnore STPP	Spec no:- PE-TS-412-501-A101
		<b>VOLUME II B</b>
		<b>SECTION-C</b>
		<b>Page 5 of 7</b>

(v) Surfaces inaccessible after assembly shall receive two coats of primer prior to assembly. Surfaces inaccessible after erection including top surfaces of floor beams, supporting gratings or chequered plate shall receive one additional coat of finish paint over the above number of coats specified before erection. Portion of steel member embedded/ to be encased in concrete shall not be painted.

**b) Painting of Mechanical components, electrical items & motors etc.**

**Surface Preparation**

Blasting according to SIS 055900 grade Sa 2½.. All the steel work shall be thoroughly cleaned of rust, scale, oil, grease, dirt and scarf by pickling, emulsion cleaning, etc. The sheet steel shall be phosphated / oven dried and then painted with two coats of zinc rich primer paint. After application of the primer, two coats of finishing synthetic enamel paint shall be applied.

**Prime Coat**

Two (2) layers of Zinc phosphate epoxy, total dry film thickness 75µm.

**Finish Coat**

Application of two (2) finishing coats of chlorinated rubber paint in approved shades at 30-40 microns DFT each coat in approved shades.

Total DFT -135-155 Microns

**Remarks**

Equipment coated with a standard application system can be accepted if the quality of this application system is corresponding with the quality of the above mentioned system.

**C) Painting of Control Panel etc.**

**Surface preparation** : Seven tank process

**Primer** : two coats of zinc rich primer paint, total dry film thickness 75µm.

**Finish Coat** : two coats of finishing epoxy paint shall be applied, 30-40 microns DFT each coat.

**Total DFT** : 135-155µm

**Or powder coating – 75 micron ( total DFT)**

**COLOR CODING PROCEDURE / SCHEME**



Technical specification  
for Double girder EOT cranes for BFP, Sea  
water Intake pump house  
( Up to 50T Cap.)  
2x660 MW SEZ ENNORE STPP

Spec no:- PE-TS-412-501-A101

**VOLUME II B**

**SECTION-C**

**Page 6 of 7**

S.No	ITEM DESCRIPT ION	REGI ON	SURFA CE PREP.	PAINTING SCHEME							COLOUR SHADE	REMARKES
				PRI MER	M IN D FT μ	INTERMED IATE	M IN D FT μ	FINI SH	M IN D FT μ	TOT AL DFT		
				As per paint specification								
a	Crane structure	-	-	-	-	-	-	-	-	-	Golden Yellow Shade 356 as per IS-5	Color band black
b	Bottom block assembly	—	—	—	—	—	—	—	—	—	Crimson shade 540 as per IS- 5	
c	Hooks	—	—	—	—	—	—	—	—	—	Crimson shade 540 as per IS- 5	
d.	End carriage sweep	—	—	—	—	—	—	—	—	—	Golden Yellow Shade 356 as per IS-5	Color band black
e.	Panels	—	—	—	—	—	—	—	—	—	Light grey 631 as per IS 5/ 7032	



**TAMIL NADU GENERATION & DISTRIBUTION  
COROPORATION LTD.**

**2X660 MW SEZ ENNORE STPP**

**DOUBLE GIRDER/ EOT CRANES  
TECHNICAL SPECIFICATION  
(ELECTRICAL PORTION)**



**BHARAT HEAVY ELECTRICALS LTD  
POWER SECTOR PROJECT ENGINEERING MANAGEMENT  
NOIDA  
INDIA**



**TITLE:**  
**ELECTRICAL EQUIPMENT SPECIFICATION  
FOR DOUBLE GIRDER EOT CRANES**  
2X660 ENNORE TPS

SPECIFICATION NO.

VOLUME NO. : II-B

SECTION: C

REV NO. : 0 DATE:

SHEET: 1 OF 2

CONTENTS

SECTION	TITLE	NO OF SHEETS
C	Specific technical requirements	2
C	Electrical scope between bhel & vendor	1
C	Technical requirements for motors	10
C	Motor Data sheet-A	1
D	Motor data sheet-C	2
D	Quality plan (for motors 55kw & above 55 kw (lv & mv) )	9
D	Quality plan (for motors below 55 kw)	2
D	Basic Technical Particulars of HT/LT motors.	6
D	Technical specification for cables	11
D	Technical specification for cable tray, fittings, accessories, junction box	4



**TITLE:**  
**ELECTRICAL EQUIPMENT SPECIFICATION  
FOR EOT CRANES / ELEVATORS / ELECTRIC HOISTS  
SYSTEM  
(ELECTRICAL PORTION)  
2X660 ENNORE TPS**

SPECIFICATION NO.

VOLUME NO. : II-B

SECTION: C

REV NO. : 0 DATE:

SHEET: 1 OF 2

**1.0 EQUIPMENT & SERVICES TO BE PROVIDED BY BIDDER:**

The equipment and services to be provided by bidder under this specification shall be as detailed here below but shall not be limited to the following:

- a) Services and Equipment as per "Electrical Scope between BHEL and Vendor".
- b) Any item/work either supply of equipment or erection material which have not been specifically mentioned but are necessary to complete the work for trouble free and efficient operation of the plant shall be deemed to be included within the scope of this specification. The bidder without any extra charge shall provide the same.
- c) Supply of mandatory spares as specified in the specifications of mechanical equipments.
- d) Erection and Commissioning spares.
- e) Erection & Maintenance tools & tackles.
- f) Electrical load requirement for EOT CRANES / ELEVATORS / ELECTRIC HOISTS System.
- g) All equipment shall be suitable for the power supply fault levels and other climatic conditions mentioned in the enclosed project information.
- h) Bidder to furnish list of makes for each equipment at contract stage, which shall be subject to customer / BHEL approval without any commercial and delivery implications to BHEL.
- i) Various drawings including GA drg, data sheet as per required format, quality plans, calculations, test reports, test certificates, operation and maintenance manuals, characteristic curves, wiring diagrams/schemes etc shall be furnished as specified at contract stage. All documents shall be subject to customer / BHEL approval without any commercial implications to BHEL.
- j) Motors shall meet minimum requirement of Electric motor specification.
- k) All routine tests and type tests reports as per applicable standards shall be furnished at contract stage.
- l) Purchaser will furnish data sheets to the vendor after award of contract. Vendor shall furnish filled in data sheets meeting the specification requirements.
- m) LV Power Cables and Control Cables shall be as per cable annexure.
- n) Cable trays shall be as per attached Cable Tray Annexure.
- o) Panel shall be as per attached Panel Annexure.
- p) Technical requirements shall be as per specifications listed in Clause 4.1 to 4.9. In case of any discrepancy between Basic technical Particulars for HT or LT motors and BHEL standard specification, Basic technical particulars for HT or LT motors shall prevail.

**2.0 EQUIPMENT & SERVICES TO BE PROVIDED BY PURCHASER FOR ELECTRICAL & TERMINAL POINTS:**

Refer "Electrical Scope between BHEL and Vendor".

**3.0 DOCUMENTS TO BE SUBMITTED ALONG WITH BID**

- 3.1 The electrical specification without any deviation from the technical/quality assurance requirements stipulated shall be deemed to be complied by the bidder in case bidder furnishes the overall compliance of package technical specification in the form of compliance certificate/No deviation certificate.
- 3.2 No technical submittal such as copies of data sheets, drawings, write-up, quality plans, type test certificates, technical literature, etc, is required during tender stage. Any such submission even if made, shall not be considered as part of offer.



**TITLE:**  
**ELECTRICAL EQUIPMENT SPECIFICATION**  
**FOR EOT CRANES / ELEVATORS / ELECTRIC HOISTS**  
**SYSTEM**  
**(ELECTRICAL PORTION)**  
**2X660 ENNORE TPS**

SPECIFICATION NO.  
VOLUME NO. : II-B  
SECTION: C  
REV NO. : 0 DATE:  
SHEET: 1 OF 2

**4 LIST OF ENCLOSURES**

- Electrical scope between BHEL & vendor.
- Technical specification – Specification for Electric Motors/Actuators
- Basic Technical Particulars of HT/LT motors.
- Testing Requirements.
- Quality Plan for LV Motors.
  
- Cable Annexure.
- Cable Tray Annexure.

REV: 00 DATE:

STANDARD ELECTRICAL SCOPE BETWEEN BHEL AND VENDOR  
 PACKAGE: DOUBLE GRIDER EOT CRANES  
 SCOPE OF VENDOR: SUPPLY , ERECTION & COMMISSIONING OF VENDOR'S EQUIPMENT  
 PROJECT :

<u>S. NO</u>	<u>DETAILS</u>	<u>SCOPE SUPPLY</u>	<u>SCOPE E&amp;C</u>	<u>REMARKS</u>
1	Isolating Switch	Vendor	Vendor	BHEL will provide one number 415 V(3ph, 4W) supply feeder only up to change over type switch for cranes at middle of the bay. Any other voltage level (AC/DC) required will be derived by the vendor. Motor starter shall be part of crane control panel.
2	Power cables, control cables, screened control cables and any special cables (if required) between equipment supplied by vendor.	Vendor	Vendor	Cable from supply feeder to isolating switch shall be in BHEL scope.
3	Cabling material (cable trays, accessories, cable tray supporting system, conduits etc).	Vendor	Vendor	
4	Equipment Earthing	Vendor	Vendor	All equipment metallic enclosures / frames, metal structure etc. shall be grounded at two points each to the nearest grounding points / risers provided by BHEL.
5	Motors	Vendor	Vendor	
6	Cable glands and lugs for equipment supplied by vendor	Vendor	Vendor	1. Double compression Ni-Cr plated brass cable glands 2. Solder less crimping type heavy duty tinned copper lugs for power & control cables.
7	a) Input cable schedules (C & I) b) Cable interconnection details for above c) Cable block diagram	Vendor Vendor Vendor	- - -	Cable listing for Control and Instrumentation Cable in enclosed excel format shall be submitted by vendor during detailed engineering stage.
8	Equipment layout drawings	Vendor	-	
9	Electrical Equipment GA drawing	Vendor	-	For necessary interface review.

## CHAPTER – 12

## MOTORS

## 1.00.00 DESIGN CRITERIA

1.00.01 For the purpose of design of equipments /systems, an ambient temperature of 50 °C and relative humidity of 85% shall be considered. The equipment shall operate in a highly polluted environment.

1.00.02 Transient voltage dip on starting of the largest motor with DOL shall be limited to 20% of the nominal system voltage at the voltage terminals.

## 1.00.03 Rating

All motors shall be continuously rated (S1 duty). However, crane motors shall be rated for S4 duty, 40% cyclic duration factor.

Whenever the basis for motor ratings are not specified in the corresponding mechanical specification sub-sections, maximum continuous motor ratings shall be at least 10% above the maximum load demand of the driven equipment under entire operating range including voltage and frequency variations.

1.00.04 Starting Voltage requirement for all motors (except mill motors):

1. 85 % of rated voltage for motors up to 1000 kW
2. 80 % of rated voltage for above 1000 kW and up to 4000 kW
3. 75 % of rated voltage for above 4000 kW

For Mill Motors:

1. 85 % of rated voltage for motors above 1000 kW
2. 90 % of rated voltage for motors up to 1000 kW

1.00.05 Canopy shall be provided for outdoor motors.

1.01.00 Contractor shall provide fully compatible electrical system, equipments, accessories and services.



- 1.02.00 All the equipment, material and systems shall, in general, conform to the latest edition of relevant National and international Codes & Standards, especially the Indian Statutory Regulations.
- 1.03.00 **Voltage and frequency variations:**  
 Frequency: (+) 3% and (-) 5%  
 Voltage : i. **AC**  
 a.  $\pm 6\%$  for 11 kV/3.3 kV  
 b.  $\pm 10\%$  for 415 V  
 Combined 10 % (absolute sum)  
 ii. **DC**- +10% to -15% for 220 V DC
- 1.04.00 All LV motors above 10 kW with S1 duty shall be compulsorily of Energy efficient level IE 2 as per IS 12615: 2011.
- 1.05.00 The responsibility of coordination with electrical agencies and obtaining all necessary clearances shall be of the contractor.
- 1.06.00 **Type**  
 AC Motors:  
 (a.) Squirrel cage induction motor suitable for direct-on-line starting.  
 (b.) Crane duty motors shall be slip ring type induction motor  
 DC Motors  
 (a.) Shunt wound.
- 1.07.00 **Temperature Rise**  
**Air cooled motors**  
 70°C by resistance method  
**Water cooled**  
 80° C over inlet cooling water temperature mentioned elsewhere, by resistance method.
- 1.08.00 **Degree of Protection**  
 Degree of protection for various enclosures shall be as follows :  
 i) Indoor motors – IP 54



- |      |  |   |       |
|------|--|---|-------|
| ii)  | Outdoor motors                                 | - | IP 55 |
| iii) | CW motors (in case of screen prot. Drip proof) | - | IP 23 |
| iv)  | Cable box – indoor area                        | - | IP 54 |
| v)   | Cable box – outdoor area                       | - | IP 55 |

**2.00.00 CODES AND STANDARDS**

2.01.00 All motors shall confirm to the latest editions including all applicable amendment of relevant IS, IEC and CBIP standards/Publications. In case any other standard is followed that ensures equal or better quality, may be accepted. However the English version of the Standard adopted shall be submitted.

2.02.00 Major Standards, which shall be followed, are listed below. Any other applicable Indian standards for any component part even if not covered in the list shall also be followed

- |     |   |   |  |
|-----|---|---|--|
| 1.) | Three phase induction motors  | : | IS:325, IEC:60034                            |
| 2.) | Single phase AC motors  | : | IS:996, IEC:60034                            |
| 3.) | Crane duty motors   | : | IS:3177, IEC:60034                           |
| 4.) | DC motors/generators  | : | IS:4722                                      |
| 5.) | Degree of protection by enclosures for rotating electrical machines                                     | : | IS: 4691<br>IS: 4728<br>IS: 6362<br>IS: 2253 |
| 6.) | Noise levels for rotating electrical machines<br>Mechanical Vibrations for rotating electrical machines | : | IS: 12065<br>IS: 12075                       |

**3.00.00 OPERATIONAL REQUIREMENTS**

3.01.00 Starting Time

3.01.01 For motors with starting time up to 20 secs at minimum permissible voltage during starting, the locked rotor withstand time under hot condition at highest voltage limit shall be at least 2.5 secs more than starting time .



- 3.01.02 For motors with starting time more than 20 secs and up to 45 secs at minimum permissible voltage during starting, the locked rotor withstand time under hot condition at highest voltage limit shall be at least 5 secs more than starting time.
- 3.01.03 For motors with starting time more than 45 secs at minimum permissible voltage during starting, the locked rotor withstand time under hot condition at highest voltage limit shall be more than starting time by at least 10% of the starting time.
- 3.01.04 Speed switches mounted on the motor shaft shall be provided in cases where above requirements are not met.
- 3.01.05 Motors shall be capable of restarting under full load after a momentary loss of voltage with the possibility of 150 % nominal voltage during fast bus transfer.
- 3.02.00 Torque Requirements
- 3.02.01 Accelerating torque at any speed with the lowest permissible starting voltage shall be at least 10% motor full load torque.
- 3.02.02 Pull out torque at rated voltage shall not be less than 205% of full load torque. It shall be 275% for crane duty motors.

#### 4.00.00 DESIGN AND CONSTRUCTIONAL FEATURES

- 4.00.01 Suitable single phase space heaters shall be provided on motors rated 30 kW and above to maintain windings in dry condition when motor is standstill. Separate terminal box for space heaters & RTDs shall be provided.
- 4.00.02 All motors shall be suitable for direct on line starting through any type of breaker.
- L All motors shall be either totally enclosed fan cooled (TEFC) or totally enclosed tube ventilated (TETV) or Closed air circuit air cooled (CACA) type. However, motors rated 3000KW or above can be Closed air circuit water cooled (CACW). CW motors can be screen protected drip proof (SPDP) type. Motors located in hazardous areas shall have flame proof enclosures conforming to IS: 2148 as detailed below

- (a) Fuel oil area : Group - IIB
- (b) Hydrogen generation plant area : Group - IIC

#### 4.00.03 Winding and Insulation

- (a) Type : Non-hygroscopic, oil resistant, flame resistant



2x660 MW Ennore SEZ Supercritical Thermal Power  
Project at Ash Dyke of NCTPS  
Spec. No. CE/C/P&E/EE/E/OT. No. 03/2013-14  
Vol. IV: Electrical Works:362



- (b) Starting duty : Two hot starts in succession, with motor initially at normal running temperature
- (c) 11 kV / 3.3 kV AC motors : Class F: with winding temperature rise limited to class B. They shall withstand 1.2/50 micro sec switching surges of 4U+5 KV (U=Line voltage in KV). The coil inter-turn insulation shall be suitable for 0.3/3 micro sec. surge of 32 KVp and 12 kVp for 11 kV ad 3.3 kV system respectively followed by 1 min power frequency high voltage test of appropriate voltage on inter turn insulation.
- (d) 415V AC & 220V DC motors : Class 'F' with temperature rise limited to class 'B'
- 4.00.04 Motors rated above 1000 kW shall have insulated bearings to prevent flow of shaft currents.
- 4.00.05 Motors with heat exchangers shall have dial type thermometer with adjustable alarm contacts to indicate inlet and outlet primary air temperature.
- 4.00.06 Noise level and vibration shall be limited within the limits prescribed in IS: 12065 & IS: 12075 respectively. Motors shall withstand vibrations produced by driven equipment.
- 4.00.07 In MV/HV motors, 12 nos. simplex or 6 nos. duplex RTDs (two per phase), each having D.C. resistance of 100 ohms at 0°C, embedded in the stator winding at locations where highest temperatures may be expected, shall be provided. The material of the ETD's shall be platinum. Each bearing shall be provided with dial type thermometer with adjustable alarm contact and resistance type temperature detector. All HV motors shall be provided with shaft grounding rings for bearing protection and earthing shaft current.
- 4.00.08 MV/HV motors shall also be capable of satisfactory operation at full load at a supply voltage of 80% of the rated voltage and shall be capable of either two starts in quick succession with third start after 5 minutes in cold condition or two starts at 15 minutes intervals in hot condition, both cases with voltage and frequency variation within specified limits.
- 4.00.09 Locked rotor current of the MV motors shall be limited to 600% (subject to IS tolerance) of the full load current of the motors and for HV motor shall be limited to 450% (inclusive of IS tolerance) of full load current of the motor.



2x660 MW Ennore SEZ Supercritical Thermal Power  
Project at Ash Dyke of NCTPS  
Spec. No. CE/C/P&E/EE/EJOT. No. 03/2013-14  
Vol. IV: Electrical Works:363



Locked rotor current of the LV motor shall not exceed 600% of full load current inclusive of IS tolerance.

- 4.00.10 MV Motors shall be provided with differential protection. These motors shall be provided with star connected stator windings. The 3 nos. current transformers, one for each phase shall be mounted in a separate compartment in the neutral side terminal box. The three phases shall be connected to form the star point after they pass through the CTs. These differential protection CTs shall be supplied loose by 11/ 3.3 kV switchgear manufacturer.
- 4.00.11 Motor body shall be grounded at two earthing points on opposite sides with two separate and distinct grounding pads complete with tapped holes, GI bolts and washers.
- 4.00.12 HV motors can be offered with either elastimould termination or dust tight phase separated double walled (metallic as well as insulated barrier) cable boxes. In case elastimould terminations are offered, then protective cover and trifurcating sleeves shall also be provided. Removable gland plates of thickness 3 mm (hot/cold rolled sheet steel) or 4 mm (non magnetic material for single core cables) shall be provided in case of cable boxes.
- 4.00.13 All motors shall be so designed that maximum inrush currents and locked rotor and pullout torque developed by them at extreme voltage and frequency variations do not endanger the motor and driven equipment.
- 4.00.14 The motors shall be suitable for bus transfer schemes provided on the 11 kV, 3.3 kV/415V systems without any injurious effect on its life.
- 4.00.15 All motors below 15 kW shall be provided with sealed ZZ bearings.
- 4.00.16 For motors rated 1000 KW & above, neutral current transformers of PS class shall be provided on each phase in a separate neutral terminal box.
- 4.00.17 All motors shall be provided with an emergency stop push button near the motor as per the Indian Statutory regulations.
- 4.00.18 The motor terminal box shall be suitable for withstanding the maximum system fault current for a duration of at least 0.25 seconds.
- 4.00.19 Neutral in case of HV motors shall be kept accessible.



- 4.00.20 Motors shall be designed to easy access for drilling holes through motor feed of mounting flange for installation of dowel pins after assembly of the motor and driven equipment.
- 4.00.21 Well spacious working platforms shall be provided around the motor area for carrying out maintenance & testing works. Platform shall be minimum of 300 mm below the level of motor base plate.
- 4.00.22 Flow switches shall be provided for monitoring oil flow of forced lubrication bearings, if used. Alarm switch contact rating shall be minimum 0.5 A at 220 V DC and 10 A at 230 V AC.
- 4.00.23 For bearing temperature measurement, duplex RTDs shall be provided for each bearing and shall be wired up to the terminal box..
- 4.00.24 Lube oil pressure transmitters shall be provided to DCS for remote monitoring. Lube oil pressure very low trip to HV equipment shall be 2 out of 3 logic.
- 4.00.25 Capillary type temperature gauge cum switch shall be provided for DE / NDE of HV Motors
- 4.00.26 Motors with CACA/CACW heat exchangers shall have dial type thermometer with adjustable alarm contacts to indicate the following:
- Hot and cold air temperatures of the closed air circuit for CACA motors.
  - Hot and cold, air and water temperatures for CACW motors.
- The Alarm switch contact rating shall be minimum 0.5 A at 220 V DC and 10 A at 230 V AC.
- 4.00.27 Lifting Provisions**
- Motor weighing 25 kg or more shall be provided with eye bolt or other adequate provision for shifting. Electrical hoists shall be provided for motors above 1000 kgs for maintenance of the same.
- 4.00.28 DC MOTORS
- DC motors shall be provided where specified/required. DC Motors shall be sized for operation with fixed resistance starting for reliability. DC motors shall be shunt wound type. Motors shall be capable of delivering the rated output at 220 V DC with (+) 10% and (-) 15% variations without exceeding its guaranteed temperature limits. 220 V DC



system shall be unearthed. Starting current of the DC motors shall be limited to 200% of the full load current of the motor, and is subject to IS tolerance. DC Motors shall be similar to AC Motors with respect to other features like enclosure type, cooling and class of insulation

#### 4.00.30 Painting

Motor including fan shall be painted with corrosion proof paints of colour shade Siemens grey (RAL 7032).

#### 4.00.31 Local Push Button Stations

The LPBS shall be installed near the motors to be controlled. Individual channel supports shall be used for each LPBS. These shall be installed as per approved erection detail drawing. LPBS for hazardous areas shall be CMRS certified and CCE approved.

All LPBS shall have necessary canopies. Wiring of LPBS shall be checked before giving control supply.

#### 5.00.00 LIST OF TESTS TO BE CONDUCTED FOR HV, MV and LV MOTORS

##### 5.01.00 TYPE TESTS

- (a) No load saturation and loss curves up to approximately 115% of rated voltage
- (b) Momentary overload test
- (c) Temperature rise test at rated conditions. During heat run test, bearing temp., winding temp., core temp., coolant flow and its temperature shall also be measured. In case the temperature rise test is carried at load other than rated load, specific approval for the test method and procedure is required to be obtained. Wherever ETD's are provided, the temperature shall be measured by ETD's also for the record purpose.
- (d) Surge withstand test on the sample coil after placing it in stator core at  $(4U + 5 \text{ KV})$  and with at least five impulse of 1.2/50 micro sec. wave, for HV motors only, where U is the line to line voltage in kV.
- (e) Surge-withstand test with 0.3/3 micro sec. wave on each type of 3.3/11 kV motor coils with at least five such impulses, followed by one minute power frequency high voltage test on turn to turn insulation, after cutting the coil and bringing out



the turns suitably. The power frequency test voltage shall be decided during detailed engineering.

- f) Dimensions (for motors covered by IS 1231:1974 and IS 2223:1983 only)
- g) Measurement of resistance of windings of stator and wound rotor.
- h) Reduced voltage running up test at no load (for squirrel cage motors up to 37kw only)
- i) Full load test to determine efficiency, power factor and slip.
- j) Insulation resistance test
- k) Test for vibration severity of motor
- l) Test for noise levels of motor
- m) Test for degree of protection by enclosure
- n) Temperature rise test at limiting values of voltage and frequency variations
- o) Over speed test

**5.02.00****ROUTINE TESTS**

The following shall constitute the routine tests.

- a) Insulation resistance test
- b) Measurement of resistance of windings of stator and wound rotor.
- c) No load test
- d) Locked rotor readings of voltage, current and power input at a suitable reduced voltage
- e) Reduced voltage running up test ( for squirrel cage motor)
- f) Open circuit voltage ratio of stator and rotor windings (for slip ring motors); rotor;
- g) High voltage test

**6.00.00****INSPECTION AND TESTING AT SITE****6.01.01**

Insulation resistance of 415V motors shall be measured between the winding of the machine and its frame by means of a 500/1000V megger. A minimum value of 1 mega ohm for 415V motors shall be considered a safe value. In case of lower I.R. Value, the insulation value shall be brought up by any of the following methods as desired by the Site Engineer:

- (a.) Blowing hot air in case of big motors.
- (b.) Putting the motor in electric oven in case of smaller motors.
- (c.) Placing heaters or lamps around and inside in case of small motors after making suitable guarding and covering arrangements so as to conserve the heat.



## 6.01.02 Site Test

- (a.) Measurement of vibration.
- (b.) Measurement of insulation resistance and polarization index.
- (c.) Measurement of full load current.
- (d.) Test running of the motors, checking the temperature rise and identifying the hot spot etc.

6.01.03 3.3 kV motors shall be tested for insulation by 500/1000V megger and its value should not be less than the safe minimum insulation of  $\geq 20 \text{ M}\Omega$  resistance at 60 deg. C. In case the insulation is low, the following method of drying has to be adopted:

- a. By locking the motor so that it cannot rotate and then applying such a low voltage to the stator terminals that full load current flows in the stator, keeping the stator winding temperature below 90 deg. C. In this a close watch shall be kept for any possible overheating and I.R. Values vs. temperature shall be plotted and heating continued till I.R. Value becomes steady.
- b. By blasting hot air from external source, Maximum temperature of winding while drying should be 70 deg. C to 80 deg. C. (Thermometer) or 90 deg. C. to 95 deg. C. by resistance method. Heating should be done slowly till steady temperature of winding is reached after 4 to 5 hours and for large machines after 10 hours. A record has to be kept for drying process, with half an hour readings and, after steady temperature is reached, at an interval of 2 hours. In case it is essential, the drying process can be supplemented by blower.



MOTOR DATA SHEET-A

SL.NO.	PARAMETERS	UNIT	ENNORE
	MOTOR		
1	DESIGN AMBIENT TEMP	DEG. C	50
2	VOLTAGE SUPPLY AND VARIATION	VOLT	415V, $\pm$ 10%
3	FREQUENCY WITH VARIATION	Hz	50 (+) 3% to (-) 5%
4	COMBINED VOLTAGE & FREQUENCY VARIATION		10%
5	MAX ACCEPTABLE RATING OF MOTOR AT 415 V	KW	160 kW
6	SYSTEM FAULT LEVEL AND ITS DURATION	KA	50 KA, 1 Sec
7	SUTABILITY OF TERMINAL BOX FOR FAULT LEVEL AND DURATION		50 KA, 0.25 sec
8	CLASS OF INSULATION & TEMP RISE LIMITED TO		Class-F and temp rise limited to Class-B
9	MIN. STARTING VOLTAGE		85%
10	MOTOR RATING FOR SINGLE PHASE SUPPLY		Upto 200W
11	MAXIMUM LOCKED ROTOR CURRENT	% OF FLC	For LT motors (except energy efficient motors) locked rotor current shall not exceed 700% of full load current inclusive of tolerance as per IS: 325. For LT energy efficient motors above 10kW with S1 duty, locked rotor current shall be as per IS: 12615-2011.
12	ACCEPTABLE NOISE LEVEL	DB	85dB at 1.0m in line with IS 12065
13	TYPE OF STARTER PROVIDED IN MCC		N.A.
14	DOP OF ENCLOSURE		Indoor motors shall conform to degree of protection IP: 54 as per IS: 4691. Outdoor motors shall conform to degree of protection IP: 55 as per IS: 4691 and shall be of weather-proof construction. The degree of protection for terminal boxes shall be IP 55 for outdoor area & IP 54 for indoor area as per IS 4691.
15	SPACE HEATER REQUIREMENT		30KW & ABOVE
16	PAINT SHADE		Shall be confirmed during detailed engineering.
17	SPECIAL REQUIREMENT		Type test to be conducted on the identical motor in the last 5 years or after the last design change, which ever is earlier. Otherwise, the equipment shall have to be type tested, free of charge, to prove the design.  All motors shall be subjected to routine tests as per IS: 325.  The motors shall generally conform to IS 325/IEC-60034.

	TITLE	SPECIFICATION NO.
	<b>MOTOR</b>  <b>DATA SHEET - C</b>	VOLUME II B
		SECTION D
		REV NO. 00 DATE
		SHEET 1 OF 2

S. No.	Description	Data to be filled by successful bidder
<b>A.</b>	<b>General</b>	
1	Manufacturer & country of origin	
2	Motor type	
3	Type of starting	
4	Name of the equipment driven by motor & Quantity	
5	Maximum Power requirement of driven equipment	
6	Rated speed of Driven Equipment	
7	Design ambient temperature	
<b>B.</b>	<b>Design and Performance Data</b>	
1	Frame size & type designation	
2	Type of duty	
3	Rated Voltage	
4	Permissible variation for	
5	a) Voltage	
6	b) Frequency	
7	c) Combined voltage & frequency	
8	Rated output at design ambient temp (by resistance method)	
9	Synchronous speed & Rated slip	
10	Minimum permissible starting voltage	
11	Starting time in sec with mechanism coupled	
12	a) At rated voltage	
13	b) At min starting voltage	
14	Locked rotor current as percentage of FLC (including IS tolerance)	
15	Torque	
	a) Starting	
	b) Maximum	
16	Permissible temp rise at rated output over ambient temp & method	
17	Noise level at 1.0 m (dB)	
18	Amplitude of vibration	
19	Efficiency & P.F. at rated voltage & frequency	
	a) At 100% load	
	c) At 75% load	

NAME OF VENDOR			SEAL	REV.	
NAME	SIGNATURE	DATE			

	TITLE	SPECIFICATION NO.
	MOTOR	VOLUME II B
	DATA SHEET - C	SECTION D
		REV NO. 00 DATE
		SHEET 2 OF 2

S. No.	Description	Data to be filled by successful bidder
	c) At starting	
<b>C.</b>	<b>Constructional Features</b>	
1	Method of connection of motor driven equipment	
2	Applicable Standard	
3	DOP of Enclosure	
4	Method of cooling	
5	Class of insulation	
6	Main terminal box	
	a) Type	
	b) Power Cable details (Conductor, size, armour/unarmour)	
	c) Cable Gland & lugs details (Size, type & material)	
	d) Permissible Fault level ( kArms & duration in sec)	
7	Space heater details (Voltage & watts)	
8	Flame proof motor details (if applicable)	
	a) Enclosure	
	b) suitability for hazardous area	
	i Zone	O / I / II
	ii Group	IIA / IIB / IIC
9	No. of Stator winding	
10	Winding connection	
11	Kind of rotor winding	
12	Kind of bearings	
13	Direction of rotation when viewed from NDE	
14	Paint Shade & type	
15	Net weight of motor	
16	Outline mounting drawing No (To be enclosed as annexure)	
<b>D.</b>	<b>Characteristic curves/ drawings</b> (To be enclosed for motors of rating $\geq$ 55KW)	
	a) Torque speed characteristic	
	b) Thermal withstand characteristic	
	c) Current vs time	
	d) Speed vs time	

NAME OF VENDOR			SEAL	REV.
NAME	SIGNATURE	DATE		

SL. NO.	COMPONENT/OPERATION	SHEET 1 OF 8	CUSTOMER :				PROJECT :				SPECIFICATION :					
			QUALITY PLAN		BIDDER/ VENDOR SYSTEM		TITLE		QUALITY PLAN		NUMBER :		SPECIFICATION :		TITLE	
			CHARACTERISTIC CHECK	CAT.	TYPE/ METHOD OF CHECK	EXTENT OF CHECK	REFERENCE DOCUMENT	ACCEPTANCE NORM	FORMAT OF RECORD	AGENCY	SECTION	P	W	V	REMARKS	
1	2	3	4	5	6	7	8	9	10	11						
1.0	RAW MATERIAL & BOUGHT OUT CONTROL		MA	VISUAL	100%	-	FREE FROM BLINKS, CRACKS, WAVINESS ETC	LOG BOOK	3	-	-					
1.1	SHEET STEEL PLATES, SECTION, EYEBOLTS		MA	MEASUREMENT	SAMPLE	MANFR'S DRG./SPEC	MANFR'S DRG./SPEC	-DO-	3	-	-					
			MA	MECH. TEST	-DO-	-DO-	-DO-	INSPEC. REPORT	3	-	2					
1.2	HARDWARES		MA	VISUAL	100%		FREE FROM CRACKS, UN-EVENNESS ETC.	-DO-	3	-	-					
			MA	VISUAL	SAMPLES	MANFR'S DRG./SPEC BOOK	RELEVANT IS/SPEC.	SUPPLIERS TC & LOG	3	-	2				PROPERTY CLASS MARKING SHALL BE CHECKED BY THE VENDOR	
1.3	CASTING		MA	VISUAL	100%		FREE FROM CRACKS, BLOW HOLES ETC.	LOG BOOK	3	-	2					
			MA	CHEM & MECH TEST	1/HEAT NO.	MANFR'S DRG./SPEC	RELEVANT IS/	SUPPLIERS TC	3	-	2				HEAT NO. SHALL BE VERIFIED	
1.4	PAINT & VARNISH		MA	MEASUREMENT	100%	MANFR'S DRG.	MANFR'S DRG.	LOG BOOK	3	-	2					
			MA	VISUAL	100% CONTINUOUS	MANFR'S DRG./SPEC	MANFR'S DRG./SPEC	LOG BOOK	3	-	2					
BHEL													PARTICULARS		BIDDER/VENDOR	
													NAME			
													SIGNATURE			
													DATE			
													BIDDERS/VENDORS COMPANY SEAL			

SL. NO.	COMPONENT/OPERATION	CUSTOMER :				PROJECT :				SPECIFICATION :						
		QUALITY PLAN		BIDDER/ VENDOR SYSTEM		TITLE		QUALITY PLAN		TITLE		SPECIFICATION :				
		SHEET 2 OF 9	CHARACTERISTIC CHECK	CAT.	TYPE/METHOD OF CHECK	EXTENT OF CHECK	REFERENCE DOCUMENT	ACCEPTANCE NORM	FORMAT OF RECORD	ITEM, AC ELECT. MOTORS 55 KW & ABOVE (LV & MV)	SECTION AGENCY	VOLUME III REMARKS	P	W	V	
1		2	3	4	5	6	7	8	9	10	11					
1.5	SHAFT (FORGED OR ROLLED)	1. SURFACE COND. 2. CHEM. & PHYSICAL PROPERTIES 3. DIMENSIONS 4. INTERNAL FLAWS	MA	VISUAL	100%			FREE FROM VISUAL DEFECTS RELEVANT IS	-DO- SUPPLIER'S TC LOG BOOK	3 3 3	- - -			VENDOR'S APPROVAL IDENTIFICATION SHALL BE MAINTAINED		
1.6	SPACE HEATERS, CONNECTORS, TERMINAL BLOCKS, CABLES, CABLE LUGS, CARBON BRUSH TEMP. DETECTORS, RTD, RTD'S	1. MAKE & RATING 2. PHYSICAL COND. 3. DIMENSIONS (WHEREVER APPLICABLE) 4. PERFORMANCE/ CALIBRATION	MA	UT	-DO-	100%	ASTM-A388	MANUF'R'S SPEC. SPEC. BHEL SPEC.	-DO- -DO-	3 3	2 2			FOR DIA OF 55 MM & ABOVE		
			MA	-DO-	-DO-			NO PHYS. DAMAGE, NO ELECTRICAL DISCONTINUITY	-DO-	3	-					
			MA	MEASUREMENT	SAMPLE			MANUF'R'S DRG./ SPEC.	-DO-	3	-					
			MA	TEST	100%			-DO-	INSP. REPORT	3	-					
BHEL													PARTICULARS		BIDDER/VENDOR	
													NAME			
													SIGNATURE			
													DATE			
													BIDDER'S/VENDORS COMPANY SEAL			

SHEET 3 OF 9		CUSTOMER :		PROJECT :		SPECIFICATION :					
		COMPONENT/OPERATION	QUALITY PLAN CHECK	BIDDER/ VENDOR SYSTEM	QUALITY PLAN TITLE	NUMBER :	TITLE	REMARKS			
SL. NO.	2	3	4	5	6	7	8	9	10	11	
		CHARACTERISTIC CHECK	CAT.	METHOD OF CHECK	EXTENT OF CHECK	REFERENCE DOCUMENT	ACCEPTANCE NORM	FORMAT OF RECORD	P	W	V
1.7	OTHER INSULATING MATERIALS LIKE SLEEVES, BINDINGS CORDS, PAPERS, PRESS BOARDS ETC.	1. SURFACE COND. ETC. 2. OTHER CHARACTERISTICS	MA	VISUAL	100%	-	NO VISUAL DEFECTS	INSPT. REPORT	3	-	2
1.8	SHEET STAMPING (PUNCHED)	1. SURFACE COND. 2. DIMENSIONS INCLUDING BURS HEIGHT 3. ACCEPTANCE TESTS	MA	TEST	SAMPLE	MANUF'S SPEC.	MANUF'S SPEC.	LOG BOOK AND OR SUPPLIER'S TC	3	-	2
1.9	CONDUCTORS	1. SURFACE FINISH 2. ELECT. PROP. & MECH. PROP	MA	MEASUREMENT	SAMPLE	MANUF'S DRG.	MANUF'S DRG.	LOG BOOK	3	-	2
				ELECT. & MECH TESTS	-DO-	MANUF'S SPEC./ RELEVANT IS	RELEVANT IS	-DO-	3	-	2
				VISUAL	100%	-	FREE FROM VISUAL DEFECTS	LOG BOOK	3*	-	2*
				ELECT. & MECH TEST	SAMPLES	RELEVANT IS/ BS OR OTHER STANDARDS	RELEVANT IS/ BS OR OTHER STANDARDS	SUPPLIERS TC & VENDOR'S INSPT. REPORTS	3	-	2
BHEL											
			PARTICULARS			BIDDER/VENDOR					
			NAME								
			SIGNATURE								
			DATE								
BIDDER'S/VENDORS COMPANY SEAL											





SL. NO.	COMPONENT/OPERATION	SHEET # OF 9	QUALITY PLAN			CUSTOMER :			PROJECT			SPECIFICATION :		
			CHARACTERISTIC CHECK	BIDDER/ VENDOR SYSTEM CAT.	TYPE/ METHOD OF CHECK	EXTENT OF CHECK	REFERENCE DOCUMENT	ACCEPTANCE NORM	FORMAT OF RECORD	TITLE	SECTION	AGENCY	REMARKS	
1	2	3	4	5	6	7	8	9	10	11	P	W	V	
2.4	SHEET STACKING	1.COMPLETENESS 2.COMPRESSION & TIGHTENING 3.CORE LOSS & HOTSPOT	MA	MEASUREMENT	SAMPLE	MANUF'R'S SPEC.	MANUF'R'S SPEC.	Log Book	2	-	-			
			MA	MEASUREMENT	100%	-DO-	-DO-	-DO-	Log Book	2	-	-		
			MA	ELECT. TEST	-DO-	-DO-	-DO-	Log Book	2	1*	1			
2.5	WINDING	1.COMPLETENESS 2.CLEANLINESS 3.IR-HV/IR 4.RESISTANCE 5.INTERTURN INSULATION 6.SURGE WITH STAND AND TAN DELTA TEST	CR	VISUAL	100%	MANUF'R'S SPEC./BHEL SPEC.	MANUF'R'S SPEC./BHEL SPEC.	Log Book	2	-	-			
			CR	-DO-	-DO-	-DO-	-DO-	Log Book	2	-	-			
			CR	ELECT. TEST	-DO-	-DO-	-DO-	Log Book	2	-	1			
			CR	-DO-	-DO-	-DO-	-DO-	Log Book	2	-	1			
			CR	-DO-	-DO-	-DO-	-DO-	Log Book	2	-	-			
			CR	-DO-	-DO-	-DO-	-DO-	Log Book	2	-	1			FOR MV MOTOR
2.6	IMPREGNATION	1.VISCOSITY 2.TEMP. PRESSURE VACCUUM 3.NO. OF DIPS	MA	PHY. TEST	AT STARTING	-DO-	-DO-	Log Book	2	-	-			
			MA	PROCESS CHECK	CONTINUOUS	-DO-	-DO-	Log Book	2	-	-			
			MA	-DO-	-DO-	-DO-	-DO-	Log Book	2	-	1			THREE DIPS TO BE GIVEN
BHEL			PARTICULARS			BIDDER/VENDOR								
			NAME											
			SIGNATURE											
			DATE											
												BIDDER'S/VENDORS COMPANY SEAL		

CUSTOMER :		PROJECT :		SPECIFICATION :							
BIDDER/ VENDOR :		TITLE :		NUMBER :							
SYSTEM :		QUALITY PLAN :		TITLE :							
CAT. :		NUMBER PED-506-00-Q-007 REV.03 :		SECTION :							
TYPE/ METHOD OF CHECK :		ITEM AC ELECT. MOTORS 55 KW & ABOVE (LV & MV) :		VOLUME III :							
EXTENT OF CHECK :		REFERENCE ACCEPTANCE NORM :		REMARKS :							
4		7		P W V							
5		8		10							
6		9		11							
1	2	3	4	5	6	7	8	9	10	11	
2.7	COMPLETE STATOR ASSEMBLY	4. DURATION 1. COMPACTNESS & CLEANLINESS	MA	-DO-	-DO-	-DO-	-DO-	Log Book	2	-	1
2.8	BRAZING/COMPRESSION JOINT	1. COMPLETENESS 2. SOUNDNESS	CR	-DO-	-DO-	-DO-	-DO-	Log Book	2	-	-
2.9	COMPLETE ROTOR ASSEMBLY	3. HV 1. RESIDUAL UNBALANCE 2. SOUNDNESS OF DIE CASTING	MA	ELECT. TEST	-DO-	-DO-	-DO-	Log Book	2	1	1
2.10	ASSEMBLY	1. ALIGNMENT 2. WORKMANSHIP 3. AXIAL PLAY 4. DIMENSIONS 5. CORRECTNESS, COMPLETENESS, TERMINATIONS/ MARKING/ COLOUR CODE 6. RTO, BTD & SPACE HEATER MOUNTING.	CR	DYN. BALANCE	-DO-	MFG SPEC/ ISO 1940	MFG. DWG.	Log Book	2	1	1
			CR	ELECT. (GROWLER TEST)	-DO-	MFG. SPEC.	MFG. SPEC.	Log Book	2	1	1
			MA	MEAS.	-DO-	-DO-	-DO-	Log Book	2	-	-
			MA	VISUAL	-DO-	-DO-	-DO-	Log Book	2	-	-
			MA	MEAS.	-DO-	-DO-	-DO-	Log Book	2	-	1
			MA	-DO-	-DO-	MFG.DRG./ MFG SPEC.	MFG.DRG./ RELEVANT IS	Log Book	2	-	-
			MA	VISUAL	100%	MFG SPEC. RELEVANT IS	MFG SPEC. RELEVANT IS	Log Book	2	-	-
			MA	VISUAL	100%	MFG SPEC. RELEVANT IS	MFG SPEC. RELEVANT IS	Log Book	2	1	1
BIHEL											
PARTICULARS											
NAME											
SIGNATURE											
DATE											
BIDDERS/VENDORS COMPANY SEAL											

S/L NO.	COMPONENT/OPERATION	SHEET # OF 9	CUSTOMER :				PROJECT :				SPECIFICATION :					
			QUALITY PLAN		BIDDER/ VENDOR		TITLE		QUALITY PLAN		TITLE		NUMBER :		SPECIFICATION :	
			CHARACTERISTIC CHECK	CAT.	TYPE/ METHOD OF CHECK	EXTENT OF CHECK	REFERENCE DOCUMENT	ACCEPTANCE NORM	ITEM. AC ELECT. MOTORS 55 KW & ABOVE (LV & MV)	SECTION	VOLUME III	AGENCY	P	W	V	REMARKS
1	3.0 TESTS	2	3	4	5	6	7	8	9	10	11					
	1. TYPE TESTS INCLUDING SPECIAL TESTS AS PER BHEL SPEC.	MA	ELECT. TEST	1/TYPE/SIZE	IS-325/ BHEL SPEC./ DATA SHEET	IS-325/ BHEL SPEC./ DATA SHEET	TEST REPORT		2	1*	1			* NOTE - 1		
	2. ROUTINE TESTS INCLUDING SPECIAL TEST AS PER BHEL SPEC.	MA	-DO-	100%	-DO-	-DO-	-DO-		2	1*	1			* NOTE - 2		
	3. VIBRATION & NOISE LEVEL	MA	-DO-	100%	IS-12075 & IS-12085	IS-12075 & IS-12085	-DO-		2	1*	1			* NOTE - 2		
	4. OVERALL DIMENSIONS AND ORIENTATION	MA	MEASUREMENT & VISUAL	100%	APPROVED DRG/DATA SHEET	APPROVED DRG/DATA SHEET & RELEVANT IS	INSPC. REPORT		2	1	-					
	5. DEGREE OF PROTECTION	MA	ELECT. & MECH. TEST	1/TYPE/ SIZE	RELEVANT IS	RELEVANT IS	TC		2	-	1			TC FROM AN INDEPENDENT LABORATORY, REFER NOTE-3		
	6. MEASUREMENT OF RESISTANCE OF RTD & BTD	MA	-DO-	100%	-DO-	-DO-	-DO-		2	1*	1			* NOTE - 2		
	7. MEASUREMENT OF RESISTANCE, IR OF SPACE HEATER	MA	-DO-	100%	-DO-	-DO-	-DO-		2	1*	1			* NOTE - 2		
	8. NAMEPLATE DETAILS	MA	VISUAL	100%	IS-325 & DATA SHEET	IS-325 & DATA SHEET	INSPC. REPORT		2	1*	1			* NOTE - 2		
	9. EXPLOSION FLAME PROOF (IF SPECIFIED)	MA	EXPLOSION FLAME PROOF TEST	1/TYPE	IS-3882 IS-8239 IS-8240	IS-3882 IS-8239 IS-8240	TC		2	-	1			TC FROM AN INDEPENDENT LABORATORY, REFER NOTE-3		
	10. PAINT SHADE, THICKNESS & FINISH	MA	VISUAL & MEASUREMENT BY ELKOMETER	SAMPLE	BHEL SPEC. & DATA SHEET	BHEL SPEC. & DATA SHEET	TC		2	1*	1			SAMPLING PLAN TO BE DECIDED BY INSPECTION AGENCY * NOTE - 2		
BHEL			PARTICULARS		BIDDER/VENDOR										BIDDER'S/VENDORS COMPANY SEAL	
			NAME		SIGNATURE		DATE									

E 605.001		QUALITY PLAN		CUSTOMER :		PROJECT TITLE		SPECIFICATION :	
SHEET 8 OF 9		CHARACTERISTIC CHECK		BIDDER/ VENDOR SYSTEM CAT.		QUALITY PLAN NUMBER PED-508-00-007, REV-03		NUMBER :	
COMPONENT/OPERATION		CHECK		TYPE/ METHOD OF CHECK		REFERENCE DOCUMENT		TITLE	
SL. NO.		3		4		7		SECTION	
2		5		6		8		AGENCY	
1		6		7		9		P W V	
		11		10		11		REMARKS	
<p>NOTES:</p> <p>1 DEPENDING UPON THE SIZE AND CRITICALLY, WITNESSING BY BHEL SHALL BE DECIDED.</p> <p>2 ROUTINE TESTS ON 100% MOTORS SHALL BE DONE BY THE VENDOR. HOWEVER, BHEL SHALL WITNESS ROUTINE TESTS ON RANDOM SAMPLES. THE SAMPLING PLAN SHALL BE MUTUALLY AGREED UPON.</p> <p>3 IN CASE TEST CERTIFICATES FOR THESE TESTS ON SIMILAR TYPE, SIZE AND DESIGN OF MOTOR FROM INDEPENDENT LABORATORY ARE AVAILABLE, THESE TEST MAY NOT BE REPEATED.</p> <p>4 WHEREVER CUSTOMER IS INVOLVED IN INSPECTION, AGENCY (1) SHALL MEAN BHEL AND CUSTOMERS BOTH TOGETHER.</p> <p><u>Legends for inspection agency</u></p> <p>1. BHEL/CUSTOMER  2. VENDOR (MOTOR MANUFACTURER)  3. SUB-VENDOR (RAW MATERIAL/COMPONENTS SUPPLIER)</p> <p>P. PERFORM  W. WITNESS  V. VERIFY</p>									
BHEL				PARTICULARS		BIDDER/VENDOR			
				NAME					
				SIGNATURE					
				DATE					
				BIDDER'S VENDORS COMPANY SEAL					

CUSTOMER :		PROJECT		SPECIFICATION :							
BIDDER/ VENDOR SYSTEM		TITLE		NUMBER :							
QUALITY PLAN		QUALITY PLAN		SPECIFICATION							
SHEET 1 OF 2		NUMBER PED-506-00-Q-006, REV-01		TITLE							
COMPONENT/OPERATION CHARACTERISTICS CHECK		ITEM AC ELECT. MOTORS BELOW 55KW (LV)		SECTION							
CAT.		REFERENCE DOCUMENT		AGENCY							
TYPE/ METHOD OF CHECK		ACCEPTANCE NORM		P W V							
EXTENT OF CHECK		FORMAT OF RECORD		REMARKS							
3		7		10							
4		8		11							
1	2	3	4	5	6	7	8	9	10	11	
1.0	ASSEMBLY	1.WORKMANSHIP 2.DIMENSIONS 3.CORRECTNESS COMPLETENESS/ TERMINATIONS/ MARKING/COLOUR CODE	MA	VISUAL	100%	MANUF'S SPEC	MANUF'S SPEC	-DO-	2	-	
2.0	PAINTING	1.SHADE	MA	VISUAL	SAMPLE	MANUF'S SPEC/BHEL SPEC./RELEVANT STANDARD	BHEL SPEC. SAME AS COL.7	LOG BOOK	2	-	
3.0	TESTS	1.ROUTINE TEST INCLUDING SPECIAL TEST AS PER BHEL SPEC. 2.OVERALL DIMENSIONS & ORIENTATION	MA	-DO-	100%	IS-325/ BHEL SPEC./ DATA SHEET	SAME AS COL.7	TEST REPORT	2	1	NOTE -1 & NOTE-3
			MA	MEASUREMENT & VISUAL	100%	APPROVED DRG/DATA SHEET	APPROVED DRG/DATA SHEET & RELEVANT IS	INSPN. REPORT	2	1	NOTE -1 & NOTE-3
BHEL		PARTICULARS		BIDDER/VENDOR							
		NAME									
		SIGNATURE									



SL NO.	COMPONENT/OPERATION CHARACTERISTICS CHECK	QUALITY PLAN	CUSTOMER :			PROJECT TITLE			SPECIFICATION :		
			BIDDER/ VENDOR SYSTEM CAT.	TYPE/ METHOD OF CHECK	EXTENT OF CHECK	ITEM AC ELECT. MOTORS BELOW 55KW (LV) DOCUMENT	ACCEPTANCE NORM	FORMAT OF RECORD	SECTION AGENCY	NUMBER :	TITLE :
1	2	3	4	5	6	7	8	9	10	11	
	3.NAMEPLATE DETAILS		MA	VISUAL	100%	IS-325 & DATA SHEET	IS-325 & DATA SHEET	INSPN. REPORT	2	1	
<p>NOTES:</p> <ol style="list-style-type: none"> <li>1 ROUTINE TESTS ON 100% MOTORS SHALL BE DONE BY THE VENDOR. HOWEVER, BHEL SHALL WITNESS ROUTINE TESTS ON RANDOM SAMPLES. THE SAMPLING PLAN SHALL BE MUTUALLY AGREED UPON</li> <li>2 WHERE EVER CUSTOMER IS INVOLVED IN INSPECTION, (1) SHALL MEAN BHEL AND CUSTOMERS BOTH TOGETHER.</li> <li>3 FOR EXHAUST/VENTILATION FAN MOTORS OF RATING UPTO 1.5KW , ONLY ROUTINE TEST CERTIFICATES SHALL BE FURNISHED FOR SCRUTINY.</li> </ol> <p><u>Legends for inspection agency</u></p> <ol style="list-style-type: none"> <li>1. BHEL/CUSTOMER</li> <li>2. VENDOR (MOTOR MANUFACTURER)</li> <li>3. SUB-VENDOR (RAW MATERIAL/COMPONENTS SUPPLIER)</li> </ol> <p>P. PERFORM W. WITNESS V. VERIFY</p>											
BHEL			PARTICULARS			BIDDER/VENDOR			BIDDER'S/VENDORS COMPANY SEAL		
			NAME								
			SIGNATURE								
			DATE								

**TAMIL NADU GENERATION & DISTRIBUTION  
CORPORATION LIMITED**

**2 X 660 MW ENNORE SEZ SUPERCRITICAL TPP**

**BASIC TECHNICAL FEATURES  
FOR HT/LT MOTORS**

**(FOR BHEL-PEM SCOPE PACKAGES)**

**DOC. NO. PE-DC-412-565-E003**

**REVISION 0**



**BHARAT HEAVY ELECTRICALS LIMITED**

**POWER SECTOR**

**POWER PROJECT ENGINEERING INSTITUTE**

**NOIDA (U.P), INDIA**



**2 x 660 MW ENNORE SEZ STPP**  
**BASIC TECHNICAL FEATURES**  
**FOR HT / LT MOTORS**  
**(FOR BHEL-PEM SCOPE PACKAGES)**

Doc. No.	PE-DC-412-565-E003
Rev. No.	0
Dated	13-01-2014
Page	1 of 6

1.0 This document covers the basic technical features of high tension (HT) and low tension (LT) squirrel cage induction AC motors employed for driving auxiliaries of BHEL-PEM scope packages in **2 x 660 MW ENNORE SEZ STPP**.

2.0 CODES AND STANDARDS

**The motors shall generally conform to IS 325/IEC-60034. LT motors above 10 kW with continuous duty (S1) shall be energy efficient IE2 conforming to IS-12615: 2011.**

3.0 DESIGN REQUIREMENTS

3.1 General Requirements

The design ambient temperature shall be 50 deg C.

3.2 Supply system and rated voltage of motors

KW rating	Supply system	Rated voltage of motor
Above 1500 kW	11 KV	11 KV
Above 160 kW up to & including 1500 kW	3.3 KV	3.3 KV
From 200W up to & including 160 kW	415 V	415 V
Below 200W	240V	240V

3.2.1 Supply voltage & variations shall be as follows:-

Voltage variation (AC Supply) (+/-) 10%  
Frequency variation (+) 3% to (-) 5%  
Combined V & F variation 10% (sum of absolute values)

3.2.2 Motors shall be capable of running continuously at rated output for each of the conditions specified.

3.3 Motor Rating

Motor ratings shall be adequate to meet the requirements of the drive equipment. Motors shall be continuously rated at the design ambient temperature of 50 degree C and relative humidity of 85%. Maximum continuous motor ratings shall have at least a 25% margin above the maximum load demand of the driven equipment under entire operating range including voltage & frequency variation.

3.4 Starting Requirements

3.4.1 Motor shall start smoothly and rapidly. Motor characteristics such as speed, starting torque, break away torque and starting time shall be properly co-ordinated with the requirements of driven equipment. The accelerating torque at any speed with the minimum starting voltage shall be at least 10% of the motor's full load torque.



**2 x 660 MW ENNORE SEZ STPP**  
**BASIC TECHNICAL FEATURES**  
**FOR HT / LT MOTORS**  
**(FOR BHEL-PEM SCOPE PACKAGES)**

Doc. No.	PE-DC-412-565-E003
Rev. No.	0
Dated	13-01-2014
Page	2 of 6

3.4.2 Motors shall be capable of starting and accelerating the load with direct on line starting without exceeding acceptable winding temperature.

Minimum Starting Voltage requirement for all motors (except mill motors):

1. 85 % of rated voltage for motors up to 1000 kW
2. 80 % of rated voltage for above 1000 kW and up to 4000 kW
3. 75 % of rated voltage for above 4000 kW

3.4.3 The locked rotor current of the HV (11 kV) motors (except MDBFP motors) shall not exceed 650% of full load current inclusive of tolerance as per IS: 325 and for MV (3.3 kV) motors locked rotor current shall not exceed 700% of full load current inclusive of tolerance as per IS: 325. For LT motors (except energy efficient motors) locked rotor current shall not exceed 700% of full load current inclusive of tolerance as per IS: 325. For LT energy efficient motors above 10kW with S1 duty, locked rotor current shall be as per IS: 12615-2011.

3.4.4 The following frequency of starts shall apply

- i) Two nos. consecutive cold starts in quick succession with third start after 5 minutes in cold condition.
- ii) Two nos. consecutive hot starts in the interval of 15 minutes in hot condition.

3.4.5 Locked motor withstand time of motors under hot condition at highest voltage limit shall be as follows:

- a) For motors with starting time up to 20 sec.  
- at least 2.5 sec. more than starting time.
- b) For motor with starting time above 20 secs but not exceeding 45 secs.  
- at least 5.0 sec. more than starting time.
- c) For motors with starting time above 45 secs.  
- at least 10% more than starting time.

The starting time of the motor referred above is at minimum permissible voltage. For motors and in cases where the above requirements are not complied with, speed switches of approved make & type shall be provided to bypass the locked rotor protection for a pre-selected time during starting of motors. The speed switches shall have one NO & one NC contacts having maximum interrupting capacity of 5 Amps at 240V AC and 0.25 amps at 220 V DC.

### 3.5 Running Requirements

3.5.1 Motors shall run satisfactorily at a supply voltage of 80% of rated voltage for 5 minutes with full load without injurious heating to the motor.

3.5.2 Pull out torque at rated voltage shall not be less than 205% of full load torque. It shall be 275% for crane duty motors.



**2 x 660 MW ENNORE SEZ STPP**  
**BASIC TECHNICAL FEATURES**  
**FOR HT / LT MOTORS**  
**(FOR BHEL-PEM SCOPE PACKAGES)**

Doc. No.	PE-DC-412-565-E003
Rev. No.	0
Dated	13-01-2014
Page	3 of 6

### 3.6 Stress during bus Transfer

- 3.6.1 Motors shall withstand the voltage and torque stress developed due to the application of 150% of the rated voltage for at least 1 sec. caused due to vect or difference between the motor residual voltage and the incoming supply voltage during occasional auto bus transfer.
- 3.6.2 Motor windings shall be adequately braced to satisfactorily withstand the mech. Stresses during above condition.
- 3.6.3 Motors shall be capable of withstanding heavy in-rush transient current caused by bus transfer without damage.
- 3.6.4 Motor and driven eqpt. Shafts shall be adequately sized to satisfactorily withstand transient torque under above condition.

### 3.7 Noise level

The maximum noise level for motors shall be in line with IS 12065.

### 3.8 Vibration

The maximum vibration for motors shall be in line with IS: 12075.

## 4.0 CONSTRUCTIONAL FEATURES

### 4.1 Degree of Protection

4.1.1 Indoor motors shall conform to degree of protection IP: 54 as per IS: 4691. Outdoor motors shall conform to degree of protection IP: 55 as per IS: 4691 and shall be of weather-proof construction. CW motors (in case of screen prot. Drip proof) shall conform to degree of protection IP: 23 as per IS: 4691. The degree of protection for terminal boxes shall be IP 55 for outdoor area & IP 54 for indoor area as per IS 4691.

4.1.2 The stator laminations shall made from suitable silicon steel/magnetic steel sheet varnished on both sides and pressed to form a rigid core.

4.1.3 The rotor shall be of rigid cage construction with die cast aluminium / copper alloy / copper bars firmly wedged in bar slots and brazed to the end rings. The rotor cage shall be designed to operate satisfactorily under respective starting and load duty cycle.

### 4.2 Enclosure and Cooling

4.2.1 Motors shall generally have totally enclosed fan cooled (TEFC) or totally enclosed tube ventilated (TETV) enclosures or Closed Air circuit Air (CACA), the method of cooling conforming to IC-0141 or IC-0151 or IC-0161 of IS: 6362 up to 3000 kW motor. CW Motors may be screen protected drip proof (SPDP).



**2 x 660 MW ENNORE SEZ STPP**  
**BASIC TECHNICAL FEATURES**  
**FOR HT / LT MOTORS**  
**(FOR BHEL-PEM SCOPE PACKAGES)**

Doc. No.	PE-DC-412-565-E003
Rev. No.	0
Dated	13-01-2014
Page	4 of 6

- 4.2.2 Motors shall not be provided with any electric or pneumatic operated external fan for cooling the motors.
- 4.2.3 Frames shall be designed to avoid collection of moisture and all enclosures shall be provided with facility for drainage at the lowest point.
- 4.3 Class of Insulation
- HT/LT motors shall have class F insulation. The temperature rise of all motors shall be limited to the limits applicable to Class 'B' insulation. In case of continuous operation at extreme voltage limits, 10deg C rise above the temperature limits specified in IS: 325 shall be permissible.
- 4.4 Bearings
- 4.4.1 Horizontally mounted motors shall have grease lubricated ball/roller or sleeve bearings. For HV/MV motors, the bearings shall be regreasable type and for LV motors, these bearings can be either sealed life lubricated type or regreasable type as per manufacturer's standard.
- 4.4.2 The vertical motors shall have a combined thrust and guide bearing on top and guide bearing at bottom. If the ball or roller bearings can take vertical thrust, thrust and guide bearing need not be provided.
- 4.4.3 After taking all motor driven equipment loads and thrust (if any) into account, the bearings shall be suitable for min. 20,000 working hours. Re-greasable bearings shall be provided with grease nipples and relief holes for on-line re-greasing and shall be suitable for 8000 working hours without changing of the grease.
- 4.4.4 The bearings of solidly coupled motors shall be of the same type as those of the driven equipment.
- 4.4.5 For motors up to 2 kW, double sealed type bearings shall be provided.
- 4.4.6 Motors rated above 1000kW shall be provided with insulated end shield on non-driving end to prevent flow of shaft current.
- 4.5 Terminals and Terminal Boxes
- 4.5.1 Motors of rating 90 kW and up to 160kW will be controlled by air circuit breaker with numerical protection. For all motors of rating up to 90kW shall be provided with MCCBs. The terminal box of motors shall be designed for the maximum fault current for a duration of at least 0.25 secs.
- 4.5.2 Unless otherwise specified or approved, phase terminal boxes of horizontal motors shall be positioned on the left hand side of the motor when viewed from the non-driving end.
- 4.5.3 For HV/MV motors, the main terminal box shall be of phase-segregated type with clamping arrangement for the terminals.
- 4.5.4 Connections shall be such that when the supply leads R, Y & B are connected to motor terminals A B & C or U, V & W respectively, motor shall rotate in an anticlockwise direction when viewed from the non-driving end. Where such motors require clockwise rotation, the supply leads R, Y, B will be connected to motor terminals A,C,B or V, W & U respectively.



**2 x 660 MW ENNORE SEZ STPP**  
**BASIC TECHNICAL FEATURES**  
**FOR HT / LT MOTORS**  
**(FOR BHEL-PEM SCOPE PACKAGES)**

Doc. No.	PE-DC-412-565-E003
Rev. No.	0
Dated	13-01-2014
Page	5 of 6

- 4.5.5 Permanently attached diagram and instruction plate made preferably of stainless steel shall be mounted inside terminal box cover giving the connection diagram for the desired direction of rotation and reverse rotation.
- 4.5.6 Motor terminals and terminal leads shall be fully insulated with no bare live parts.
- 4.5.7 Separate terminal boxes shall be provided for space heaters and temp. Indicators. If this is not possible in case of LT motors, the space heater terminals shall be adequately segregated from the main terminals in the main terminal box. Detachable gland plates with double compression tinned brass glands shall be provided in terminal boxes.
- 4.5.8 Phase terminal boxes shall be suitable for 360 degree of rotation in steps of 180 and 90 degree for HT and LT motors respectively.
- 4.5.9 Cable glands and cable lugs as per selected cable sizes shall be provided in line with cable erection philosophy. For single core cable termination, gland plates shall be of non-magnetic material.

#### 4.6 Grounding

Two separate earthing terminals suitable for connecting G.I. strip grounding conductor shall be provided on opposite sides of motor frame. Each terminal box shall have a grounding terminal.

#### 4.7 General

- 4.7.1 Motors provided for similar drives shall be interchangeable.
- 4.7.2 An arrow block shall be screwed on the body of the motors on the non-driving end to indicate the direction of rotation of the motors.
- 4.7.3 Motors for Fuel oil unloading and drain oil pumps located in hazardous areas shall be with flame-proof enclosures in accordance with IS 2148 / IEC 60079.
- a) Fuel oil area: Group - IIB.
- b) Hydrogen generation plant area: Group - IIC

#### 5.0 ACCESSORIES

##### 5.1 SPACE HEATERS

All motors rated 30KW and above shall be provided with space heaters to maintain the motor internal air temperature above the dew point. Space heaters shall be suitable for a supply of 240V AC, single phase, 50 Hz.

The leads from space heaters of each motor shall be brought out to a separate terminal Box. Space heaters shall be mounted inside the motor in accessible places so that their removal and replacement is simple.



**2 x 660 MW ENNORE SEZ STPP**  
**BASIC TECHNICAL FEATURES**  
**FOR HT / LT MOTORS**  
**(FOR BHEL-PEM SCOPE PACKAGES)**

Doc. No.	PE-DC-412-565-E003
Rev. No.	0
Dated	13-01-2014
Page	6 of 6

## 5.2 RESISTANCE TEMPERATURE DETECTORS (RTDs)

5.2.1 HV/MV motors stator windings shall be provided with 12 nos. Simplex 3 wire Platinum RTDs with 100 ohms resistance at 0 deg C for remote monitoring of winding temperature. The leads from RTDs of each motor shall be brought out to a separate terminal Box.

5.2.2 For HV/MV motors, each bearing shall be provided with 1 no. Duplex 3 wire Platinum RTDs with 100 ohms resistance at 0 deg C for remote monitoring of bearing temperature. The leads from these RTDs shall be brought out to a separate terminal Box or the terminal box same as for winding RTDs.

## 5.3 DIAL TYPE TEMP. INDICATORS

5.3.1 For HV/MV motors, each bearing shall be provided with dial type thermometer with adjustable alarm contact and resistance type temperature detector. The indicators shall have 2 nos. NO contacts rated for 5A, 240 V AC and 0.5 A, 220 V DC for alarm/trip purpose.

## 5.4 Vibration monitoring pads

5.4.1 Provision shall be made in all HV/MV motors for mounting vibration detectors.

## 6.0 NAME PLATE

Motors shall have stainless steel name plate with all particulars as per IS: 325. In addition bearing identification number and type of lubricant is to be indicated.

## 7.0 PAINTING

Motor including fan shall be painted with corrosion proof paints of colour shade Siemens grey (RAL 7032).

## 8.0 TESTING

### 8.1 Type Tests

For HT & LT Motors, type test reports for type tests as per IS: 325/ IS: 12615 conducted on equipment similar to those proposed to be supplied and carried out within last five years shall be submitted. However, if such reports are not available, one motor of each type shall be subjected to type tests for free of cost.

### 8.2 Routine Tests

All motors shall be subjected to routine tests as per IS: 325/ IS: 12615 in the presence of customer or customer representative.

**CHAPTER - 16****LV CABLES****1.00.00 CODES AND STANDARD**

1.01.00 All standards, specifications and codes of practice referred to herein shall be the latest editions including all applicable official amendments and revisions as on date of opening of bid. In case of conflict between this specification and those (IS: codes, standards, etc.) referred to herein, the former shall prevail. All the cables shall conform to the requirements of the following standards and codes:

IS : 3961	Recommended current ratings for cables
IS : 3975	Low carbon galvanised steel wires, formed wires and tapes for armouring of cables.
IS : 4905	Methods for random sampling.
IS : 5831	PVC insulation and sheath of electrical cables.
IS:7098 (Part -I)	Cross linked polyethylene insulated PVC sheathed cables for working voltages up to and including 1100V.
IS : 8130	Conductors for insulated electrical cables and flexible cords.
IS : 10418	Specification for drums for electric cables.
IS : 10810	Methods of tests for cables.
ASTM-D -2843	Standard test method for density of smoke from the burning or decomposition of plastics.
ASTM-D-2863	Standard method for measuring the minimum oxygen concentration to support candle like combustion of plastics.
IEC-60754 (Part-I)	Test on gases evolved during combustion of electric cables.
IEEE-383	Standard for type test of Class IE Electric Cables.
IEC -60332	Tests on Electric cables under fire conditions.



2x660

2x660 MW (1320 MW) (Tamil Nadu)  
Sri Lanka  
Vol. IV : Electrical Works Part - 16



	Part-3 : Tests on bunched wires or cables (category -B)
SS-4241475 classF3	Swedish Chimney test
NES-715-1	Temperature index

**2.00.00 TECHNICAL REQUIREMENTS**

- 2.01.01 The cables shall be suitable for laying on racks, in ducts, trenches, conduits and under ground buried installation with chances of flooding by water.
- 2.01.02 Cables, shall be flame retardant, low smoke (FRLS) type designed to withstand all mechanical, electrical and thermal stresses develop under steady state and transient operating conditions as specified elsewhere in this specification.
- 2.01.03 Aluminium conductor used in power cables shall have tensile strength of more than 100 N/ sq.mm. Conductors shall be multi stranded.
- 2.01.04 XLPE insulation shall be suitable for a continuous conductor temperature of 90 deg. C and short circuit conductor temperature of 250°C.
- 2.01.05 The cable cores shall be laid up with fillers between the cores wherever necessary. It shall not stick to insulation and inner sheath. All the cables, other than single core unarmoured cables, shall have distinct extruded PVC inner sheath of black colour as per IS: 5831.
- 2.01.06 For single core armoured cables, armouring shall be of aluminium wires/ formed wires. For multicore armoured cables armouring shall be of galvanised steel as follows :-

Calculated nominal dia of cable under armour	Size and Type of armour
i) Up to 13 mm	1.4mm dia GS wire
ii) Above 13 & upto 25mm	0.8 mm thick GS formed wire / 1.6 mm dia GS wire
iii) Above 25 & upto 40 mm	0.8mm thick GS formed wire / 2.0mm dia GS wire
iv) Above 40 & upto 55mm	1.4 mm thick GS formed wire /2.5mm dia GS wire
v) Above 55 & upto 70 mm	1.4mm thick GS formed wire / 3.15mm dia GS wire
vi) Above 70mm	1.4 mm thick GS formed wire / 4.0 mm dia GS wire



2.01.07 The aluminium used for armouring shall be of H4 grade as per IS:8130 with maximum resistivity of 0.028264 ohm mm<sup>2</sup> per meter at 20 deg C. Aluminium armouring shall be same as indicated above for galvanized steel.

2.01.08 The gap between armour wires / formed wires shall not exceed one armour wire / formed wire space and there shall be no cross over / over-riding of armour wire / formed wire. The minimum area of coverage of armouring shall be 90%. The breaking load of armour joint shall not be less than 95% of that of armour wire / formed wire. Zinc rich paint shall be applied on armour joint surface of G.S.wire/ formed wire

**2.01.09 Cable Identification**

1. Outer sheath shall be of PVC (of suitable grade) & black in colour. In addition to meeting all the requirements of Indian standards referred to, outer sheath of all the cables shall have the following FRLS properties.

(a.) Oxygen index of min. 21 (As per NES-715-1)

(b.) Acid gas emission of max. 20% (As per IEC-60754-I).

(c.) Smoke density rating shall not be more than 60% during Smoke Density Test as per ASTM-D-2843.

2. Cores of the cables shall be identified by colouring of insulation. Following colour scheme shall be adopted:

1 core - Red, Black, Yellow or Blue

2 core - Red & Black

3 core - Red, Yellow & Blue

4 core - Red, Yellow, Blue and Black

3. For reduced neutral conductors the core shall be black.

4. In addition to manufacturer's identification on cables as per IS, following marking shall also be provided over outer sheath.

(a.) Cable size and voltage grade - To be embossed



- (b.) Word 'FRLS' at every 5 metre - To be embossed
- (c.) Sequential marking of length of the cable in metres at every one metre-  
To be embossed / printed

The embossing shall be progressive, automatic, in line and marking shall be legible and indelible.

5. Cores of the cables of upto 5 cores shall be identified by colouring of insulation. Following colour scheme shall be adopted.

- 1 core - Red, Black, Yellow, Blue
- 2 core - Red & Black
- 3 core - Red, Yellow & Blue

2.01.10 All cables shall meet the fire resistance requirement of IEEE - 383 with cable installations made in accordance with clause "Flammability test" and as per Category-B of IEC 60332 Part -3.

2.01.11 Allowable tolerances on the overall diameter of the cables shall be  $\pm 2$  mm maximum over the declared value in the technical data sheets.

2.01.12 In plant repairs to the cables shall not be accepted. Pimples, fish eye, blow holes etc, are not acceptable.

### 3.00.00 Cable selection & sizing

3.01.00 Cables shall be sized based on the following considerations:

- i. Rated current of equipment.
- ii. Maximum voltage drop limits under steady state and during starting for motor being fed from 415V switchgear restricted to 5% and 15% respectively.

Maximum voltage drop limits under steady state and during starting for motor being fed from 415V MCC restricted to 3% and 15% respectively.



Maximum voltage drop limits under steady state for feeder (i.e. Outgoing feeders being fed from 415V switchgear) restricted to 3%.

- iii. For cables to motors and feeders protected by MCCBs the cross section will be chosen according to the tripping time of MCCBs.

3.02.00 Derating Factors

Derating factors for various conditions of installations including the following shall be considered while selecting the cable sizes:

- i. Variation in ambient temperature for cables laid in air
- ii. Grouping of cables
- iii. Variation In ground temperature and soil resistivity for buried cables.

3.03.00 Cable lengths shall be considered in such ways that straight through cable joints are avoided.

3.04.00 Cables shall be armoured type if laid in switchyard area, coal handling area or directly buried.

3.05.00 All LV power cables except trailing cables shall be XLPE insulated FRLS.

3.06.00 All control cables shall be 2.5 Sq mm copper cable.

3.07.00 Multicore control cables will generally have spare conductor (s) in accordance with the following chart and cores of a single cable will not be split for different auxiliary/equipment:

Conductors	required Cables
1 or 2	1-3/C
3 or 4	1-5/C
5 or 6	1-7/C
7 or 8	1-10/C
9 or 10	1-12/C
11 or 12	1-16/C
13 or 14	1-18/C
Above 14 core	Two or more of above cables



**4.00.00 CONSTRUCTIONAL FEATURES****04.01.00 1.1 KV Grade Power Cables**

- (d.) 1.1 KV grade XLPE power cables shall have compacted aluminium conductor for cables including 10 sq. mm and above and copper conductor for cables below 10 sq.mm, XLPE insulated, PVC inner-sheathed (as applicable), armoured, FRLS PVC outer-sheathed conforming to IS: 7098. (Part-I).
- (e.) 1.1 KV grade Trailing cables shall have tinned copper (class 5) conductor, insulated with heat resistant elastomeric compound based on Ethylene Propylene Rubber (EPR) suitable for withstanding 90°C continuous conductor temperature and 250 deg C during short circuit, inner-sheathed with heat resistant elastomeric compound, nylon cord reinforced, outer-sheathed with heat resistant, oil resistant and flame retardant heavy duty elastomeric compound conforming to IS 9968

**4.02.00 1.1 kV Grade Copper Conductor Fire Survival Power Cables**

4.02.01 1100 volt grade, 90 Deg.C rating, Power cables with stranded Copper conductor, heat resistance elastomeric insulation generally conforming to Type IE-2 of IS: 6380-1984, extruded Halogen free or very low Halogen elastomeric inner sheath, generally conforming to Type SE-3 of IS-6380-1984, round wire/strip armour and extruded outer sheath of elastomeric material generally conforming to Type SE-3 of IS: 6380-1984.

4.02.02 The cables shall be generally manufactured in conformity to IS-9968 Part-1/1988.

4.02.03 The cables shall be rated for 3 hours fire rating.

4.02.04 Conductor shall be of stranded construction, consisting of high conductivity annealed plain copper wires conforming to Class-II of IS 8130.  
A suitable heat barrier tape, preferably glass mica tape shall be provided over the conductor.

4.02.05 The insulation shall consist of heat resisting elastomeric material EPR ( Ethylene Propylene rubber) and shall conform to Type IE-2 of IS:6380/1984 amended up to date.



- 4.02.06 The suitable fire retardant material fillers shall be used for filling in the interstices. Two layers of plain glass fiber binder tape shall be applied over the laid up cores.
- 4.02.07 Fire Survival Power & Control cables shall be provided for the following services:
- (a.) DC emergency lube oil pump.
  - (b.) Turbine lube oil pump/barring gear.
  - (c.) Jacking oil pump.
  - (d.) Scanner air fan.
  - (e.) Incoming & outgoing cables for DC lighting distribution board.
  - (f.) Fire /smoke detection system.
  - (g.) DC seal oil pump.
  - (h.) DC emergency lighting cables for Main Plant Building.
  - (i.) Batteries to charger and DC distribution board.
  - (j.) Emergency turbine trip by push button in control room.
  - (k.) Boiler turbine: Generator inter-trip which includes the interconnecting cables between
    1. Boiler master fuel trip and turbine trip relays
    2. Generator trip relays and turbine trip relays
    3. Generator trip relays and 400 kV circuit breaker
    4. Generator trip relays and generator field breaker.
    5. Generator trip relays and UAT breaker.

**4.03.00 1.1 KV Grade Control Cable**

Control cable shall be multi core, minimum 2.5 sq.mm cross section, stranded copper conductor, PVC insulated, inner PVC sheathed / galvanized steel wire armored and outer sheath made of FRLS PVC compound. In situation where accuracy of measurement or voltage drop in control circuit, warrant, higher cross sections as required shall be used. 4 sq.mm copper conductors shall be used for CT circuits, all other specification remaining same. In 4 sq.mm conductor impose unacceptable high burden on CTs, higher cross section of conductor shall be used.

Voltage Transformer leads shall be checked for voltage drop, which shall be limited to within 1 % for all cases other than tariff metering, for which the voltage drop shall be limited to 0.2 %. In case the voltage drop with 4 sq.mm Cu conductors exceeds this value, higher conductor sizes shall be used.



- 4.04.00 1.1 kV Copper Conductor Fire Survival Control Cables**
- 4.04.01 Conductor shall be of stranded construction, consisting of high conductivity annealed tinned copper conductors conforming to IS 8130/1984 amended up to date.
- 4.04.02 A suitable heat barrier tape, preferably glass mica tape shall be provided over the conductor.
- 4.04.03 The conductor insulation shall consist of heat resisting elastomeric material EPR (Ethylene Propylene rubber) and shall conform to Type IE-2 of IS:6380/1984 amended up to date.
- 4.04.04 An inner sheath of extruded special low smoke and very low halogen content (acid gas generation shall be less than 2% by weight) elastomeric (HOFR) compound of black colour or any other natural colour with prior approval from Owner conforming to Type SE-3 of IS-6380/1984, amended up to date, shall be provided over the laid up cores.
- 4.04.05 The armouring over inner sheath shall consist of single layer of wire/round galvanized steel wire as per IS 3975 amended up to date.
- 4.04.06 The outer sheath shall be of special low smoke and very low Halogen content (Acid gas generation shall be less than 2% by weight) elastomeric HOFR compound comprising of synthetic rubber and shall generally conform to the type SE-3 of IS: 6380 latest revision.
- 4.04.07 The colour of outer sheath shall be black or any other natural colour agreed mutually between Owner and Contractor.
- 4.04.08 The minimum sizes of L.T. cable to be chosen are as below:  
AL-16 mm<sup>2</sup> (3 core) & Cu – 2.5 mm<sup>2</sup> (3 core)
- In power cables maximum conductor size to be used will be 300 sq. mm & 630 sq.mm for multi core and single core cables. In case of multi core cables not more than 3 runs to be used or otherwise single core cable to be used.



**4.05.00 Cable Drums**

Cables shall be supplied in non returnable wooden or steel drums of heavy construction. The surface of the drum and the outer most cable layer shall be covered with water proof cover. Both the ends of the cables shall be properly sealed with heat shrinkable PVC/ rubber caps secured by 'U' nails so as to eliminate ingress of water during transportation, storage and erection. Wood preservative anti-termite treatment shall be applied to the entire drum. Wooden drums shall comply with IS: 10418.

**5.00.00 TESTS****5.01.00 Type Tests:**

**5.01.01** The reports for the following type tests shall be submitted on one size each of LV Power cables :

S.No.	Type Tests	Remarks
a)	<b>For Conductor</b>	
1.	Annealing test	For copper conductor only.
2.	Tensile test	For aluminium conductor only.
3.	Wrapping test	For aluminium conductor only.
4.	Resistance test	
b)	<b>For Armour Wires/ Formed Wires</b>	
1.	Measurement of Dimensions	
2.	Tensile Test	
3.	Elongation test	
4.	Torsion test	For round wires only
5.	Winding test	For Formed wires only
6.	Resistance test	
7(a)	Zinc Coating test	For G.S. Formed wires /wires only.



7(b)	Wrapping test	For Al. Formed wires /wires
c)	<b>For XLPE insulation &amp; PVC Sheath</b>	
1.	Test for thickness	
2.	Tensile strength & elongation tests before ageing and after ageing	
3.	Ageing in air oven	
4.	Loss of mass test	For PVC sheath only
5.	Hot deformation test	For PVC sheath only
6.	Heat shock test	For PVC sheath only
7.	Shrinkage test	
8.	Thermal stability test	For PVC sheath only
9.	Hot set test	For XLPE insulation only
10.	Water absorption test	For XLPE insulation only
11.	Oxygen index test	For outer sheath only
12.	Smoke density test	For outer sheath only
13.	Acid gas generation test	For outer sheath only
d)	<b>For completed cables</b>	
1.	Insulation resistance test (Volume resistivity method)	
2.	High voltage test	
3.	Flammability test as per clause "Flammability test"	
4.	Flammability test as per IEC - 332 Part-3 (Category -B)	



**5.01.02 Flammability Test**

- (f.) This test shall generally be carried out as per IEEE 383. The cable installation to be tested shall consist of as many cables as are necessary to give atleast 10 kg of organic material per metre run.
- (g.) The following cable installation shall be tested :
- (1.) Installation with single / multi core cables in touching formation.
- (h.) Size of cables, number of cables, number of layers and laying arrangements for each installation shall be subject to Owner's approval.
- (i.) The size of the cables selected (measured by total cross sectional area of the conductor) shall have maximum organic material per sq. mm of total cross sectional area of all the conductors.

**5.01.03 Acceptance Tests**

Acceptance tests shall be carried out on each type and size of the cables on the cable drums selected at random as per following sampling plan:

S. No.	No. of drums in the lot	No. of drums to be taken as sample
1.	Upto 100	10% (Subject to minimum of 1 drum)
2.	101 to 300	13
3.	301 to 500	20
4.	Above 500	32

The following shall constitute acceptance tests :

- Item No. 1 to 14, 16, 19, 20, 22, 23, 24, 25 of list of type tests specified in 9.03.01 of chapter 15.
- Fire resistance test as per SS 4241475 (F3 category)
- One length per size / lot for surface finish and length measurement
- Lay length / sequence of cores, armour coverage, Gap between two consecutive armour wires / formed wires, Band marking.

**5.01.04 Routine Tests**

Routine tests shall be carried out as per relevant standard for each drum of cables of all types and sizes.



**4.00.00 EQUIPMENT DESCRIPTION****4.01.00 Cable trays, Fittings & Accessories**

4.01.01 Cable trays shall be ladder/perforated type as specified complete with matching fittings (like brackets, elbows, bends, reducers, tees, crosses, etc.), accessories (like side coupler plates, etc.) and hardware (like bolts, nuts, washers, G.I. strap, hook etc.) as required. Cable tray shall be ladder type for power & control cables and perforated for instrumentation cables.

4.01.02 These shall be either prefabricated hot dip galvanized sheet steel trays or site fabricated angle iron trays free from flaws such as laminations, rolling marks, pitting etc. These (including hardware) shall be hot dip galvanized as per relevant IS.

4.01.03 Cable trays shall have standard width of 150 mm, 300 mm & 600 mm and standard lengths of 2.5 metre. Minimum thickness of mild steel sheets used for fabrication of cable trays and fittings shall be 2 mm. The thickness of side coupler plates shall be minimum 3 mm.

4.01.04 Cable troughs shall be required for branching out few cables from main cable route. These shall be U-shaped, fabricated of mild steel sheets of minimum thickness 2 mm and shall be hot dip galvanized as per relevant IS. Troughs shall be standard width of 50 mm & 75 mm with depth of 25 mm.

4.01.05 Prefabricated hot dip galvanized sheet steel cable trays shall be used for maximum support span of 2000 mm unless design is approved for larger span. Cable trays shall be suitable for a cable weight of 100 kg/meter running length of tray. Minimum thickness of sheet steel/galvanizing shall be 2mm/86 microns respectively. The amount of zinc deposit shall not be less than 610 gm per square meter.

4.01.06 Cable trays fabricated from standard rolled sections shall be 50x50x6/75x75x6 sections for runners for supporting spans limited to 2000 mm/more than 2000 mm respectively. Cross support shall be 32x6 mm / 50x6 flat for widths up to 500mm/more than 500mm respectively.

4.01.07 Separate coloured paint strips shall be applied for identification of different type of trays depending upon types of usage/applications/area as below:



High/ medium voltage cables: red strips, 2 inch width each, numbers

11kV/3.3kV equally spaced at 5 metres interval

1.1kv power cables : yellow strips ----- do -----

1.1kv control cables : blue strips ----- do -----

Instrumentation cables : green strips ----- do -----

#### 4.02.00 Support System for Cable Trays

4.02.01 Cable tray support system shall be pre-fabricated similar or equivalent to "Unistrut make".

4.02.02 Support system for cable trays shall essentially comprise of the two components i.e. main support channel and cantilever arms. The main support channel shall be of two types: (i) C1:- having provision of supporting cable trays on one side and (ii) C2:- having provision of supporting cable trays on both sides. The support system shall be the type described hereunder

- a. Cable supporting steel work for cable racks/cables shall comprise of various channel sections, cantilever arms, various brackets, clamps, floor plates, all hardware such as lock washers, hexagon nuts, hexagon head bolt, support hooks, stud nuts, hexagon head screw, channel nut, channel nut with springs, fixing studs, etc.
- b. The system shall be designed such that it allows easy assembly at site by using bolting. All cable supporting steel work, hardware's fittings and accessories shall be prefabricated factory galvanised.



- c. The main support and cantilever arms shall be fixed at site using necessary brackets, clamps, fittings, bolts, nuts and other hardware etc. to form various arrangements required to support the cable trays. Welding of the components shall not be allowed. However, welding of the bracket (to which the main support channel is bolted) to the overhead beams, structural steel, insert plates or reinforcement bars will be permitted. Any cutting or welding of the galvanized surface shall be brushed and red lead primer, oil primer & aluminium paint shall be applied.
- d. All steel components, accessories, fittings and hardware shall be hot dip galvanized after completing welding, cutting, drilling and other machining operation.
- e. The main support channel and cantilever arms shall be fabricated out of minimum 2.5 thick rolled steel sheets conforming to IS.
- f. Cantilever arms of 300 mm, 600 mm and 750 mm in length are required. The arm portion shall be suitable for assembling the complete arm assembly on to component constructed of standard channel section. The back plate shall allow sufficient clearance for fixing bolt to be tightened with tray in position.
- g. Cable trays in areas subjected to excessive coal dust or mechanical damage shall have hot dip galvanized sheet steel metal trays cover installed on front tray in vertical run and inverted 'V' type on upper tray in horizontal run with consideration for ventilation.
- h. FRP Cable trays shall be used for areas like intake raw water pump house, Desalination plant, CHP, Battery room, NDCT and chemical house.

## 4.02.03

The size of structural steel members or thickness of sheet steel of main support channel and cantilever arms and other accessories as indicated above are indicative only. Nevertheless, the support system shall be designed by the contractor to fully meet the requirements of type tests as specified. In case the system fails in the tests, the components design modification shall be done by the Contractor without any



additional cost. The contractor shall submit the detailed drawings of the system offered by him along with the bid.

**4.03.00 Pipes, Fittings & Accessories**

4.03.01 Pipes offered shall be complete with fittings and accessories (like tees, elbows, bends, check nuts, bushings, reducers, enlargers, coupling caps, nipples etc.) The size of the pipe shall be selected on the basis of maximum 40% fill criteria

4.03.02 GI Pipes shall be of medium duty as per IS: 1239

4.03.03 Duct banks shall be High Density PE pipes encased in PCC (10% spare of each size, subject to minimum one) with suitable water-proof manholes.

**4.04.00 Junction Boxes**

4.04.01 Junction Boxes shall comprise of a case with hinged door constructed from cold rolled sheet steel of minimum thickness 2mm. Top of the boxes shall be arranged to slope towards rear of the box. Gland plate shall be 3 mm thick sheet steel with neoprene/synthetic rubber gaskets. All junction boxes shall be of adequate strength and rigidity, hot dip galvanised as per relevant IS, and suitable for mounting on wall, columns, structures etc. The boxes shall include brackets, bolts, nuts, screws M8 earthing stud etc. required for installation.

4.04.02 Glass Fibre Reinforced Junction Boxes

No. of Ways: 12/24/36/48 with 20% spares terminals.

4.04.03 Junction boxes shall be Glass Fibre Reinforced with saturated polyester conforming to standards like DIN 16911 type 803/16913 type 834, 5 self extinguishing in accordance with ASTM D635/UL 94 VO.

Junction boxes for use in outdoor or damp locations shall be sturdy construction. Temperature resistance shall be between – 10 to 100°C. Impact resistance shall be greater than 7 Nm, (EN 50014). Protective insulation shall be in line with VDE 0100, dielectric strength shall be greater than 10 KV/mm, halogen free toxicity, the enclosure and door cover shall be painted and electro statically power coated (preferably in RAL 7032). Earth connection (studs size shall be M 6) shall be provided on the cover as well as door.





TECHNICAL SPECIFICATION FOR  
DOUBLE GIRDER EOT CRANE UP TO 50T CAPACITY  
FOR BC BAY AND SEA WATER INTAKE PUMP HOUSE  
2X660 MW ENNORE SEZ STPS

SPECIFICATION NO. PE-TS-412-501-A002

Vol IIB

Rev 00

June 2015

Page 1 of 7

**ANNEXURE I**  
**LIST OF MAKES OF SUB-VENDOR ITEMS**

SR. NO.	ITEM	SUPPLIERS	PLACE	REMARKS
1.	STEEL	SAIL		
		TISCO		
		JINDAL		
		ESSAR		
2.	HOOKS	STEEL FORGING & ENGG. CO.,	KOLKATA	
		SIMRITI FORGING		
		KARACHIWALA		UP TO 25T CAPACITY
		IRIZAR FORGE		FOR MORE THAN 250T CAPACITY
3.	GEAR COUPLINGS	ALLIANCE		
		FLEX-TRANS (formerly known as HICLIFF)		
		SAHARA		
		NUTECH		
		OEM		
4.	WIRE ROPE	USHA MARTIN		
		FORT WILLIAMS		
		BHARAT WIRE ROPES		
5.	BEARINGS	SKF		
		FAG		
		TATA		
		NBC		
6.	MOTORS	SIEMENS		
		NGEF (up to 15KW)		
		CROMPTON		
		KIRLOSKAR		
		BHARAT BIJLI		
		MARATHON		
7.	BRAKES	ABB		
		ELECTROMAG		
		SPEED-O- CONTROL		
		BCH		FOR DCEM BRAKES ONLY
8.	CONTACTOR	KAKKU		
		SIEMENS		
		L&T		
		SCHNEIDER (Earlier TELE MECHANIQUE)		
9.	OVER LOAD RELAYS	BCH		
		SIEMENS		
		L&T		
		ABB		
		SCHNEIDER (Earlier TELE MACHANIQUE)		



**TECHNICAL SPECIFICATION FOR  
DOUBLE GIRDER EOT CRANE UP TO 50T CAPACITY  
FOR BC BAY AND SEA WATER INTAKE PUMP HOUSE  
2X660 MW ENNORE SEZ STPS**

SPECIFICATION NO. PE-TS-412-501-A002

Vol IIB

Rev 00

June 2015

Page 2 of 7

SR. NO.	ITEM	SUPPLIERS	PLACE	REMARKS
10.	HRC FUSES	SIEMENS		
		L&T		
		ENGLISH ELECTRIC		
		GE POWER		
		EATON (BUSSMANN)		
11.	ISOLATING SWITCH	ABB		
		SIEMENS		
		L&T		
		CONTROL & SWITCH GEAR		
		ABB		
12.	SWITCH FUSE UNITS	SIEMENS		
		L&T		
		CONTROL & SWITCH GEAR		
		ABB		
13.	TIME DELAY RELAYS	SIEMENS		
		L&T		
		ABB		
		BCH		
		SCHNEIDER (Earlier TELE MACHANIQUE )		
14.	TRANSFORMERS	INDCOIL		
		LOGICSTAT		
		KAPPA		
		AUTOMATIC ELECTRIC		
		PRECISE ELECTRICALS		
		SILKAAN ELECTRIC MFG. CO. LTD.		
		SOUTHERN ELECTRIC		
15.	BULB & FLOURESCENT TUBES/FITTINGS	NEC		
		PHILIPS		
		BAJAJ		
16.	CABLE LUGS (HEAVY DUTY)	CROMPTON		
		DOWELLS		
		UML ENGINEERS	KOLKATA	
17.	HOOTERS	JAINSON		
		BEACON		
		OSC		
		TARGET		
18.	LIGHTING SWITCHES	KHERAJ		
		ANCHOR		
		ELLORA		
		BAJAJ		
19.	PVC POWER CABLES	PHILIPS		
		APAR INDUSTRIES LTD.	MUMBAI	
		CORDS CABLE INDUSTRIES	NEW DELHI	



TECHNICAL SPECIFICATION FOR  
DOUBLE GIRDER EOT CRANE UP TO 50T CAPACITY  
FOR BC BAY AND SEA WATER INTAKE PUMP HOUSE  
2X660 MW ENNORE SEZ STPS

SPECIFICATION NO. PE-TS-412-501-A002

Vol IIB

Rev 00

June 2015

Page 3 of 7

SR. NO.	ITEM	SUPPLIERS	PLACE	REMARKS
		LTD.		
		DIAMOND POWER INFRASTRUCTURE LTD	VADODARA	
		GOYOLENE FIBRES (INDIA) PVT.LTD	MUMBAI	
		GOVIND CABLE INDUSTRIES	KOLKATA	
		GUPTA POWER INFRASTRUCTURE LIMITED	BHUBNESWAR	
		HAVELLS INDIA LIMITED	NOIDA	
		KEI INDUSTRIES LTD.	NEW DELHI	
		KRISHNA ELECTRICAL INDUSTRIES LTD	GWALIOR	
		KEC INTERNATIONAL LIMITED	MUMBAI	
		MANSFIELD CABLES COMPANY LTD.	NOIDA	
		NICCO CORPORATION LTD.	KOLKATA	
		PARAMOUNT COMMUNICATIONS LTD.	NEW DELHI	
		POLYCAB WIRES PVT. LTD.	MUMBAI	
		RADIANT CORPORATION PRIVATE LIMITED	HYDERABAD	
		RAVIN CABLES LIMITED	MUMBAI	
		SUYOG ELECTRICALS LTD.	VADODARA	
		SRIRAM CABLES PVT. LTD.	NEW DELHI	
		SCOT INNOVATION WIRES AND CABLES PVT. LTD.	SOLAN	
		SAM CABLES & CONDUCTORS (P) LTD	UDHAM SINGH NAGAR	
		THERMO CABLES LTD	HYDERABAD	
		ADVANCE CABLE TECHNOLOGIES (P) LTD	BANGALORE	
		APAR INDUSTRIES LTD., CMI LTD	MUMBAI	
		CMI LIMITED	FARIDABAD	
		CORDS CABLE INDUSTRIES LTD	NEW DELHI	
		CRYSTAL CABLE INDUSTRIES LTD	KOLKATA	
		DELTON CABLES LTD	NEW DELHI	
		DIAMOND POWER INFRASTRUCTURE LTD	VADODARA	
		ELKAY TELELINKS LTD	NEW DELHI	
		GEMSCAB INDUSTRIES LTD	NEW DELHI	
		GOVIND CABLE INDUSTRIES	KOLKATA	
		GUPTA POWER INFRASTRUCTURE LIMITED	BHUBNESWAR	
		HAVELLS INDIA LIMITED	NOIDA	
		INCOM CABLES (P) LTD	NEW DELHI	
20.	PVC CONTROL CABLES			



**TECHNICAL SPECIFICATION FOR  
DOUBLE GIRDER EOT CRANE UP TO 50T CAPACITY  
FOR BC BAY AND SEA WATER INTAKE PUMP HOUSE  
2X660 MW ENNORE SEZ STPS**

SPECIFICATION NO. PE-TS-412-501-A002

Vol IIB

Rev 00

June 2015

Page 4 of 7

SR. NO.	ITEM	SUPPLIERS	PLACE	REMARKS
		KEI INDUSTRIES LTD	NEW DELHI	
		KRISHNA ELECTRICAL INDUSTRIES LTD	GWALIOR	
		KEC INTERNATIONAL LIMITED	MUMBAI	
		MANSFIELD CABLES COMPANY LTD	NOIDA	
		NICCO CORPORATION LTD	KOLKATA	
		PARAMOUNT COMMUNICATIONS LTD	NEW DELHI	
		POLYCAB WIRES PVT. LTD	MUMBAI	
		RAVIN CABLES LIMITED	MUMBAI	
		SUYOG ELECTRICALS LTD	VADODARA	
		SPECIAL CABLES PVT. LTD	NEW DELHI	
		SCOT INNOVATION WIRES AND CABLES PVT. LTD	SOLAN	
		SAM CABLES & CONDUCTORS (P) LTD	UDHAM SINGH NAGAR	
		SPM POWER & TELECOM PVT. LTD	HYDERABAD	
		TORRENT CABLES LTD	AHMEDABAD	
		THERMO CABLES LTD	HYDERABAD	
		TIRUPATI PLASTOMATICS PVT. LTD	JAIPUR	
		UNIVERSAL CABLES LTD	SATNA	
21.	TRAILING CABLES	NICCO	KOLKATA	
		UNIVERSAL	SATNA	
		INCAB		
		ICL	NEW DELHI	
		APAR INDUSTRIES LTD	MUMBAI	
		CMI LTD	FARIDABAD	
		KEI INDUSTRIES LTD	NEW DELHI	
		SUYOG ELECTRICALS LTD	VADODARA	
22.	XLPE POWER CABLES	APAR INDUSTRIES LTD	MUMBAI	
		CORDS CABLE INDUSTRIES LTD	NEW DELHI	
		CRYSTAL CABLE INDUSTRIES LTD	KOLKATA	
		DIAMOND POWER INFRASTRUCTURE LTD	VADODARA	
		GEMSCAB INDUSTRIES LTD	NEW DELHI	
		GOVIND CABLE INDUSTRIES	KOLKATA	
		GUPTA POWER INFRASTRUCTURE LIMITED	BHUBNESWAR	
		HAVELLS INDIA LIMITED	NOIDA	
		KEI INDUSTRIES LTD	NEW DELHI	
		KRISHNA ELECTRICAL	GWALIOR	



**TECHNICAL SPECIFICATION FOR  
DOUBLE GIRDER EOT CRANE UP TO 50T CAPACITY  
FOR BC BAY AND SEA WATER INTAKE PUMP HOUSE  
2X660 MW ENNORE SEZ STPS**

SPECIFICATION NO. PE-TS-412-501-A002

Vol IIB

Rev 00

June 2015

Page 5 of 7

SR. NO.	ITEM	SUPPLIERS	PLACE	REMARKS
		INDUSTRIES LTD		
		KEC INTERNATIONAL LIMITED	MUMBAI	
		MANSFIELD CABLES COMPANY LTD	NOIDA	
		PARAMOUNT COMMUNICATIONS LTD	NEW DELHI	
		POLYCAB WIRES PVT. LTD	MUMBAI	
		RAVIN CABLES LIMITED	MUMBAI	
		SUYOG ELECTRICALS LTD	VADODARA	
		SPECIAL CABLES PVT. LTD	NEW DELHI	
		SCOT INNOVATION WIRES AND CABLES PVT. LTD	SOLAN	
		SRIRAM CABLES PVT. LTD	NEW DELHI	
		TORRENT CABLES LTD	AHMEDABAD	
		THERMO CABLES LTD	HYDERABAD	
		TIRUPATI PLASTOMATICS PVT. LTD	JAIPUR	
		APAR INDUSTRIES LTD	MUMBAI	
		CABLE CORPORATION OF INDIA LTD	MUMBAI	
		CRYSTAL CABLE INDUSTRIES LTD	KOLKATA	
		DIAMOND POWER INFRASTRUCTURE LTD	VADODARA	
		GEMSCAB INDUSTRIES LTD	NEW DELHI	
		HAVELLS INDIA LIMITED	NOIDA	
		KEI INDUSTRIES LTD	NEW DELHI	
		KRISHNA ELECTRICAL INDUSTRIES LTD	GWALIOR	
		KEC INTERNATIONAL LIMITED	MUMBAI	
		PARAMOUNT COMMUNICATIONS LTD	NEW DELHI	
		POLYCAB WIRES PVT. LTD	MUMBAI	
		RADIANT CORPORATION PRIVATE LIMITED	HYDERABAD	
		RAVIN CABLES LIMITED	MUMBAI	
		SUYOG ELECTRICALS LTD	VADODARA	
		SRIRAM CABLES PVT. LTD	NEW DELHI	
		TORRENT CABLES LTD	AHMEDABAD	
		UNIVERSAL CABLES LTD	SATNA	
		COMMET		
		SUNIL&CO		
		ARUP ENGINEERING		
		JAINSON		
		DOWELL		
24.	<b>CABLE GLAND</b>	SIEMENS		
25.	<b>PUSH BUTTONS</b>	SIEMENS		



**TECHNICAL SPECIFICATION FOR  
DOUBLE GIRDER EOT CRANE UP TO 50T CAPACITY  
FOR BC BAY AND SEA WATER INTAKE PUMP HOUSE  
2X660 MW ENNORE SEZ STPS**

SPECIFICATION NO. PE-TS-412-501-A002

Vol IIB

Rev 00

June 2015

Page 6 of 7

SR. NO.	ITEM	SUPPLIERS	PLACE	REMARKS
		L&T		
		BCH		
		SCHNEIDER		
26.	LIMIT SWITCHES	SPEED-O-CONTROL		
		ELECTROMAG		
27.	MASTER CONTROLLER	SPEED-O-CONTROL		
		ELECTROMAG		
28.	SAFETY SWITCHES	ALSTOM		
		L&T		
		SIEMENS		
29.	PENDENT PUSH BUTTON STATION	OEM		
30.	INDICATING LAMPS	TECKNIC		
		BCH		
		SIEMENS		
		STANDARD		
31.	MCB	MDS		
		INDO COPP		
		STANDARD		
		SIEMENS		
		L&T		
		ABB		
		SCHNEIDER		
32.	PANELS	OEM		
		RITTAL		
		PYROTECH		
33.	RESISTANCE BOXES	ENAPROS		
		OEM		
34.	FIRE EXTINGUISHERS	ASKA EQUIPMENTS LTD.		
		ASHOKA ENGINEERING COMPANY		
		KANADIA FYR FYTER PVT. LTD		
		NITIN FIRE PROTECTION INDUSTRIES LTD		
		NEW ENGINEERING CORPORATION		
		SAFEX FIRE SERVICES LTD		
		UNITED FIRE EQUIPMENTS PVT. LTD		
		ZENITH FIRE SERVICES (INDIA) PVT LTD		
35.	VVVF	YASKAWA		
		ABB		
		SIEMENS		
		SCHNIEDER		



TECHNICAL SPECIFICATION FOR  
DOUBLE GIRDER EOT CRANE UP TO 50T CAPACITY  
FOR BC BAY AND SEA WATER INTAKE PUMP HOUSE  
2X660 MW ENNORE SEZ STPS

SPECIFICATION NO. PE-TS-412-501-A002

Vol IIB

Rev 00

June 2015

Page 7 of 7

SR. NO.	ITEM	SUPPLIERS	PLACE	REMARKS
		FUJI ELECTRIC		
		MITSUBISHI ELECTRIC		
36.	SHROUDED DSL	SUSHEEL		
		STROMAG		
37.	ANTI COLLISION DEVICE	ELECTRONIC SWITCHES INDIA		
38.	LOAD CELL	IPA		
		SARTORIUS		
39.	RRC	ACROPOLIS ENGINEERING	-	
		SNT CONTROLS	-	
40.	GEAR BOX	OEM		* = Applicable for Geared Motors only
		ELECON ENGINEERS		
		SHANTI GEARS		
		PBL*		
		NAW*		
		NORD*		
		SEW*		
		BONGFILIOLI*		
41.	RAIL	JSPL		
		SAIL		

**NOTE:**

1. THE SUB VENDOR LIST ABOVE IS INDICATIVE ONLY AND IS SUBJECT TO BHEL AND CUSTOMER APPROVAL DURING DETAILED ENGINEERING STAGE WITHOUT ANY COMMERCIAL & DELIVERY IMPLICATION TO BHEL.

BIDDER TO PROPOSE SUB VENDOR WITHIN 4 WEEKS OF PLACEMENT OF LOI. THEREAFTER NO REQUEST FOR ADDITIONAL SUB-VENDOR SHALL BE ENTERTAINED.

2. DEALERS ARE NOT ACCEPTABLE FOR ANY ITEM OF THE PACKAGE. BIDDER SHALL PROCURE ALL ITEMS INCLUDING PLATES, STRUCTURAL, FLANGES; COUNTER FLANGES ETC. FROM APPROVED SUB VENDOR ONLY.
3. THE INSPECTION CATEGORY WILL BE INTIMATED AFTER AWARD OF CONTRACT BY BHEL/CUSTOMER. HOWEVER THE SAME WILL BE ADHERED BY THE BIDDER WITHOUT ANY COMMERCIAL AND DELIVERY IMPLICATION TO BHEL/ CUSTOMER.

	<b>TECHNICAL SPECIFICATION FOR DOUBLE GIRDER EOT CRANE FOR BFP, SEA WATER INTAKE PUMP HOUSE ( Up to 50T Capacity) 2X660 MW SEZ ENNORE,</b>	<b>Specification no.: PE-TS-412-501-A101</b>
		<b>Rev. 00</b>
		<b>Date: June 2015</b>
		<b>Sheet</b>

**ANNEXURE-II**

**Mandatory Spares:**

( Spares to be provided for each crane)	
Description	Quantity
<b>SPARES FOR LONG TRAVEL UNIT</b>	
SET OF AXLE BEARINGS	1 SET
SET OF GEARBOX BEARINGS WITH SLEEVES	1 SET
LONG TRAVEL END SHAFT BEARINGS	1 SET
COUPLING	1 SET
SEALS FOR TRAVEL GEAR BOX	1 SET
LONG TRAVEL BRAKE SHOES	1 SET
LONG TRAVEL BRAKE SPRINGS	1 SET
LONG TRAVEL BRAKE SHOE LINERS	1 SET
<b>SPARES FOR CROSS TRAVEL UNIT</b>	
AXLE BEARINGS	1 SET
SET OF GEARBOX BEARINGS WITH SLEEVES	1 SET
SET OF SEALS FOR GEARBOX	1 SET
CROSS TRAVEL END SHAFT BEARING	1 SET
COUPLING	1 SET
CROSS TRAVEL BRAKE SHOES	1 SET
CROSS TRAVEL BRAKE SPRINGS	1 SET
CROSS TRAVEL BRAKE SHOE LINERS	1 SET
<b>SPARES FOR MAIN HOIST</b>	
MAIN HOIST PULLEY BEARINGS	1 SET
SET OF BEARINGS FOR RODE DRUM	1 SET
SET OF BEARINGS FOR GEAR BOX	1 SET
SET OF SEALS FOR MAIN HOIST	1 SET
MAIN HOIST BRAKE SHOES	1 SET
MAIN HOIST BRAKE SPRINGS	1 SET
MAIN HOIST BRAKE SHOE LINERS	1 SET
DISC PAD	1 SET
Description	Quantity

	<b>TECHNICAL SPECIFICATION FOR DOUBLE GIRDER EOT CRANE FOR BFP, SEA WATER INTAKE PUMP HOUSE ( Up to 50T Capacity) 2X660 MW SEZ ENNORE,</b>	<b>Specification no.: PE-TS-412-501-A101</b>
		<b>Rev. 00</b>
		<b>Date: June 2015</b>
		<b>Sheet</b>

<b>ELECTRICAL: CONTROL PANELS/MOTORS</b>	
POWER CONTACTOR OF EACH RATING	2 NOS.
OVER LOAD RELAYS OF EACH RATING	2 NOS.
MCCB/MPCB OF EACH RATING	2 NOS.
PUSH BUTTON OF EACH TYPE	2 NOS.
VVVF drive module card	1 SET
SET OF BEARINGS FOR MAIN HOIST MOTOR	1 SET
SET OF BEARINGS FOR AUX HOIST MOTOR	1 SET
SET OF BEARINGS FOR CROSS TRAVEL MOTOR	1 SET
SET OF BEARINGS FOR LONG TRAVEL MOTOR	1 SET
Motor of each type & rating	<b><u>10% of the installed quantity or minimum 1 number whichever be higher</u></b>

NOTE :-

a) 1 set means 100% requirement for One crane.

b) Quantity of spares specified above is for one crane, for two nos cranes for BFP the same shall be doubled. For One no. crane for sea water intake pump house spare for one no. crane to be provided.



Technical specification  
for Double girder EOT cranes for BFP, Sea  
water Intake pump house  
( Up to 50T Cap.)  
2x660 MW SEZ ENNORE STPP

Spec no:- PE-TS-412-501-A101

Volume-II B

SECTION-C

## ANNEXURE III

### FORMAT FOR OPERATION & MAINTENANCE MANUAL

Project name:

Project number:

Package Name:

Sl.no. & Sections	Description	Yes	No	Not Applicable	Remarks
1.	Cover page				
1.1	Project Name				
1.2	Customer Name				
1.3	Name of Package				
1.4	Supplier details with phone, FAX email address				
1.5	Name and sign of prepared by , checked by & approved by				
2.0	Index				
2.1	showing the sections & related page nos All the pages should be numbered section wise				
3.0	Description of Plant				
3.1	Description /write up of operating principle of system equipment/ associated sub-systems & accessories/controls system , operating conditions, performance parameters under normal , start up and special cases				
3.2	Equipment list and basic parameter with Tag numbers				
3.3	Data sheets approved by Customer/for information and catalogues provided by original manufacturer				
3.4	Associated other packages and Interface /terminal points				
3.5	P&ID & Process Diagrams				
3.6	GA Layout drawings, As-built drawings				
3.7	Single line/wiring diagrams				
3.8	Control philosophy /control write-ups				
4.0	Commissioning Activities (if not covered in separate document i.e. erection manual, commissioning manual)				
4.1	Pre-Commissioning Checks				
4.2	Transportation and handling at site				
4.3	Storage at site				
4.4	Unpacking & Installation procedure				
5.0	Operation Guidelines for plant personal/user/operator				
5.1	Interlock & Protection logic along with the				



TECHNICAL SPECIFICATION FOR CW PUMP  
HOUSE CRANE ( 60/18 T CAPACITY)  
2x660 MW SEZ ENNORE STPP

Tech. Spec. no. :- PE-TS-412-501-A002

Volume-II B

SECTION-C

Rev 00

06.06.15

	limiting values of protection settings for the equipment along with brief philosophy behind the logic, drawings etc. to be provided.				
<b>5.2</b>	Start up and shut down procedure for equipments along with the associated systems in step by step mode. Valve sequence chart, step list, interlocks etc with Equipment isolating procedures to be mentioned.				
<b>5.3</b>	Do's & Don't of the equipments.				
<b>5.4</b>	Safety precautions to be taken during normal operation. Safety symbols, Emergency instructions on total power failure condition/lubrication failure/any other condition				
<b>5.5</b>	Parameters to be monitored with normal values and limiting values				
<b>5.6</b>	Trouble shooting with causes and remedial measures				
<b>5.7</b>	Routine operational checks, recommended logs & records				
<b>5.8</b>	Changeover schedule if more than one auxiliary for the same purpose is given				
<b>5.9</b>	Painting requirement and schedule				
<b>5.10</b>	Inspection, repair , Testing and calibration procedures				
<b>6.0</b>	Maintenance guidelines for plant personal				
<b>6.1</b>	List of Special Tools and Tackles required for Overhaul/Trouble shooting including special testing equipment required for calibration etc.				
<b>6.2</b>	Stepwise dismantling and re-assembly procedure clearly specifying the tools to be used, checks to be made, records to be maintained, clearances etc. to be mentioned. Tolerances for fitment of various components to be given.				
<b>6.3</b>	Preventive Maintenance & Overhauling schedules linked with running hours/calendar period along with checks to be given				
<b>6.4</b>	Long term maintenance schedules especially for structural, foundations etc.				
<b>6.5</b>	Consumable list along with the estimated quantity required during commissioning, normal running and during maintenance like Preventive Maintenances and Overhaul.				
<b>6.6</b>	List of lubricants with their Indian equivalent, Lubrication Schedule, Quantity required for each equipment for complete replacement is to be given				
<b>6.7</b>	List of vendors & Sub-vendors with their latest addresses, service centres ,Telephone Nos., Fax Nos., Mobile Nos., e-mail IDs etc.				



TECHNICAL SPECIFICATION FOR CW PUMP  
HOUSE CRANE ( 60/18 T CAPACITY)  
2x660 MW SEZ ENNORE STPP

Tech. Spec. no. :- PE-TS-412-501-A002

Volume-II B

SECTION-C

Rev 00

06.06.15

<b>6.8</b>	List of mandatory and recommended spare parts list				
<b>6.9</b>	Tentative Lead time required for ordering of spares from the equipment supplier				
<b>6.10</b>	Guarantee and warranty clauses				
<b>7.0</b>	Statutory and other specific requirements considerations.				

	TECHNICAL SPECIFICATION FOR DOUBLE GIRDER EOT CRANE FOR BFP & SEA WATER INTAKE PUMP HOUSE CRANE ( UP to 50T)	Spec. No. PEM(Q)/001
		Page 1 of 5
		Section –C , dtd June 2015

ANNEXURE-IV

PART OF SPECIFICATION NO PE-TS-412-501-A101

1.0.0	<b>Scope: Acceptance Norms for Crane Gear Boxes</b>
1.1.0	<p>This procedure lays down the Acceptance norms for the Gear boxes for EOT crane. This standard also covers vertical gear boxes.</p> <p>Reduction Gears shall be tested for reduction ratio, backlash &amp; contact pattern. Gear Box shall also be subjected to No load run test to check for oil leakage, temp. rise, noise and vibration.</p>
2.0.0	The following dimensions shall be checked:
2.1.0	<ul style="list-style-type: none"> <li>i. Diameter and keyway dimensions of input and output shafts.</li> <li>ii. Projection of input and output shafts beyond foundation holes and Centre lines of gear box.</li> <li>iii. Centre distance between input and output shafts.</li> <li>iv. Centre Height.</li> <li>v. Distance between foundation holes with respect to center line of the output shaft and distance of foundation holes from center line of the gearbox.</li> <li>vi. Overall dimensions</li> </ul>
3.0.0	<b>Backlash</b>
3.1.0	The back lash shall be checked by dial gauge preferably (refer Figure –1). Lead wire may be also be used but final decision in case of dispute shall be taken by using dial gauge. The backlash shall be within the limits specified in the drawing. If the value of the backlash allowed is not specified in the drawing, the allowed backlash shall be a given in Table-1
4.0.0	<b>Area of Contact:</b>
4.1.0	<p>Area of contact shall be taken by applying Prussian blue. The contact area shall be within the limits mentioned below (refer Figure –2)</p> <p>For final stage of Hoist gearing:</p> <p><math>h / H</math> shall be more than 30%</p> <p><math>(a - c) / b</math> shall be more than 40%</p> <p>For all other gears:</p> <p><math>h / H</math> shall be more than 40%</p> <p><math>(a - c) / b</math> shall be more than 50%</p>
5.0.0	Running Test
5.1.0	The gear boxes shall be run under no-load condition at the rated speed for minimum

	<b>TECHNICAL SPECIFICATION FOR DOUBLE GIRDER EOT CRANE FOR BFP &amp; SEA WATER INTAKE PUMP HOUSE CRANE ( UP to 50T)</b>	Spec. No. <b>PEM(Q)/001</b>
		Page 2 of 5
		Section –C , dtd June 2015

ANNEXURE-IV

PART OF SPECIFICATION NO PE-TS-412-501-A101

	<p>four hours in each direction and the following are to be checked:</p> <ul style="list-style-type: none"> <li>i. All bolts at the joints remain tight</li> <li>ii. All gear mesh lines are getting enough lubrication</li> <li>iii. All bearings are getting enough lubrication</li> <li>iv. Bearing temperatures after running for four hours shall not exceed 50 deg. Centigrade or 15 deg. centigrade above ambient whichever is higher. Temperature shall be checked after every hour.</li> <li>v. Vibration : Maximum limit 125 microns (peak to peak)</li> <li>vi. Sound: The gearbox shall not emit unusual sound as obtained under conditions of hard meshing, high spots etc. Maximum sound level shall be 85 dBA at a distance of 1000mm and 91 dBA at a distance of 300 mm.</li> <li>vii. There shall be no Oil leakage at parting lines, bearing housings or inspection covers.</li> </ul>
<b>6.0.0</b>	General
6.1.0	<p>In addition to the above specific points, the following general points shall be ensured:</p> <ul style="list-style-type: none"> <li>i. Inspection pockets are provided as required.</li> <li>ii. Gear box casings are provided with at least two fit bolts/dowels at the parting line.</li> <li>iii. Dip sticks with minimum / maximum level markings are provided.</li> <li>iv. Drain plugs are provided at convenient locations preferably at vertical wall of the housing.</li> <li>v. Breathers are provided.</li> <li>vi. Lifting lugs or eye bolts ar provided as required.</li> <li>vii. Wherever bearings have splash lubrication, oil retainers are provided.</li> <li>viii. Gear boxes are painted as per specification outside and inside. Inside surfaces shall be painted with Oil proof paint.</li> <li>ix. In case of vertical gear boxes having more than two stage reduction, forced lubrication is also provided.</li> </ul> <p>Name plate should provide information eg. Ratio, KW rating, Bearing details and manufacturers name.</p>

	TECHNICAL SPECIFICATION FOR DOUBLE GIRDER EOT CRANE FOR BFP & SEA WATER INTAKE PUMP HOUSE CRANE ( UP to 50T)	Spec. No. PEM(Q)/001
		Page 3 of 5
		Section -C , dtd June 2015

ANNEXURE-IV

PART OF SPECIFICATION NO PE-TS-412-501-A101

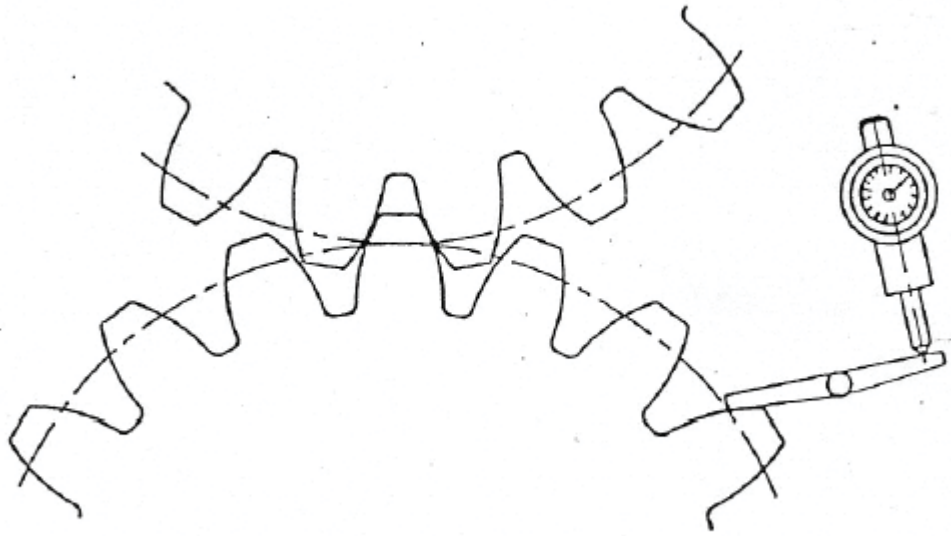

FIG.1 MEASUREMENT OF BACKLASH

TECHNICAL SPECIFICATION FOR DOUBLE GIRDER EOT CRANE FOR BFP & SEA WATER INTAKE PUMP HOUSE CRANE ( UP to 50T)	Spec. No. PEM(Q)/001
	Page 4 of 5
Section -C , dtd June 2015	

ANNEXURE-IV

PART OF SPECIFICATION NO PE-TS-412-501-A101

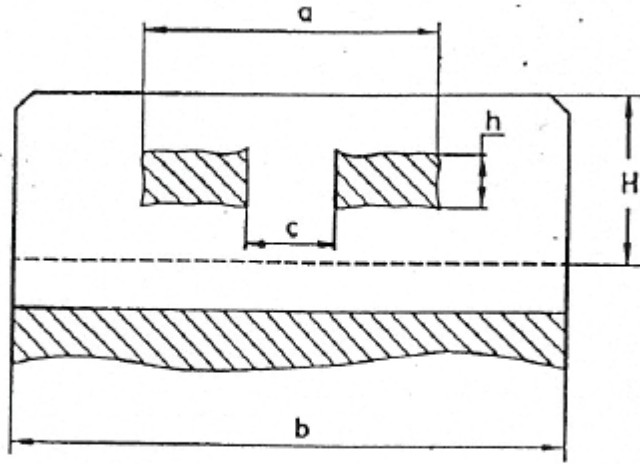

FIG.2 AREA OF CONTACT OF GEAR TEETH

Table-1

Backlash for Gearing specified by module  
(Clause 3.1.0)

Centre distance in mm		Tolerances in microns		
Above	Upto	Minimum	Maximum	
			For gears other than Drum gears	For Drum gears
			For all modules 1 to 50	For all modules 2.5 to 50
-	50	85	240	280
50	80	105	320	380
80	120	130	360	420
120	200	170	470	530
200	320	210	540	640
320	500	260	660	740
500	800	340	820	880

	TECHNICAL SPECIFICATION FOR DOUBLE GIRDER EOT CRANE FOR BFP & SEA WATER INTAKE PUMP HOUSE CRANE ( UP to 50T)	Spec. No. PEM(Q)/001
		Page 5 of 5
		Section –C , dtd June 2015

ANNEXURE-IV

PART OF SPECIFICATION NO PE-TS-412-501-A101

800	1250	420	970	1040
1250	2000	530	1200	1280
2000	3150	710	1500	1670
3150	5000	850	1810	1980



## **TECHNICAL SPECIFICATION FOR**

**DOUBLE GIRDER EOT CRANE FOR BFP, SEA WATER  
INATEK PUMP HOUSE  
2X660 MW SEZ ENNORE STPP**

SPECIFICATION NO. PE-TS-412-501-A101

VOLUME II - B

**SECTION -C**

EV 00

June 2015

Page 1 of 2

### ANNEXURE-IV

#### **Procedure for Load/Overload testing of EOT cranes at Manufacturer's Works**

**Objective:** To demonstrate final No load / Load / Overload / Deflection / Functional tests of assembled crane/s for the purpose of acceptance.

#### **Basic Assumptions / Inputs for testing at Works:**

- Actual job hook shall be used for load / overload tests for hoisting.
- Actual ropes shall be used for load / overload testing.
- Shop cables can be used for temporary connection for the purpose of showing various functional tests at shop.
- Interlock and limit switch operation check will be shown with load for hoisting and CT motion.

#### **Procedure for Load / Overload testing:**

The cranes shall be tested for no load ,load test & overload test at works generally in conformance with the IS – 3177 (latest edition). Specifically with respect to the load / overload testing of crane, the following tests as per the outlined procedures shall be done at works.

- Deflection of the girder will be measured at SWL when the trolley with load is at the middle of the girder.
- No load and full load current of the motors will be measured to verify whether it is as per the approved data sheet of the motor. Resistors in the circuit will be checked for any overheating of the element.
- Overload relays will be checked for proper functioning.

#### **Hoisting & Cross Travel motions:**

The load will be gradually raised to 125 percent of the rated capacity (SWL) with actual hook. The load will be lifted upward to about 1 meter height above its support and stop again. Check for any undue drift in the load. If load drifts, check the adjustment of brakes and repeat the above procedure. Then lower the load to rest on support/ground.

**TECHNICAL SPECIFICATION FOR**

**DOUBLE GIRDER EOT CRANE FOR BFP, SEA WATER  
INATEK PUMP HOUSE  
2X660 MW SEZ ENNORE STPP**

SPECIFICATION NO. PE-TS-412-501-A101

VOLUME II - B

**SECTION -C**

EV 00

June 2015

Page 1 of 2

For checking the cross travel, raise the load up to one (1) meter height above supports and then move the trolley with load about one (1) meter in either direction of the bridge. Then lower the load to rest on support/ground.

Creep speed motions shall be checked over a distance of about 500 mm.

**Note: Complete No load / load / over load tests in line with IS-3177 (latest edition) shall also be done after erection & commissioning of EOT crane at site.**



Technical specification  
for Double girder EOT cranes for BFP, Sea  
water Intake pump house  
( Up to 50T Cap.)  
2x660 MW SEZ ENNORE STPP

Spec no:- PE-TS-412-501-A101

VOLUME III

SECTION -D

Rev 00

13.05.15

## ANNEXURE-V

**DRAWINGS/ DOCUMENTS TO BE SUBMITTED AFTER AWARD OF CONTRACT**

The successful bidder shall submit the following drawings / documents during detail engineering for customer's approval /information:

S.N.	BHEL drawing No.	Title	Approval category	Schedule date of submission from date of LOI.
1	PE-VO-MOU-501-A100	Manufacturing Quality Plan with sub vendor list	APPROVAL	3
2	PE-VO-MOU-501-A101	Data sheet of DG EOT Crane with painting details	APPROVAL	3
3	PE-VO-MOU-501-A102	Data sheet of motors	INFORMATION	6
4	PE-VO-MOU-501-A103	Mechanism Sizing Calculation for DG EOT crane	APPROVAL	3
5	PE-VO-MOU-501-A104	General arrangement for DG EOT crane with CT DSL details	APPROVAL	3
6	PE-VO-MOU-501-A105	Crab sub assembly for DG EOT crane with CT wheel assembly	INFORMATION	4
7	PE-VO-MOU-501-A106	Gantry Rail installation for DG EOT crane	APPROVAL	3
8	PE-VO-MOU-501-A107	General arrangement for PVC shrouded DSL for DG EOT crane	APPROVAL	3
9	PE-VO-MOU-501-A108	Main hook block assembly with details of hook, nut and check plate	APPROVAL	4
10	PE-VO-MOU-501-A109	Long travel Machinery Assembly for DG EOT crane with LT wheel assembly	INFORMATION	4
11	PE-VO-MOU-501-A110	Lifting beam assembly for DG EOT crane (If applicable)	APPROVAL	6
12	PE-VO-MOU-501-A111	Structural calculations	APPROVAL	4
13	PE-VO-MOU-501-A112	Crane lubrication drawing	INFORMATION	6
14	PE-VO-MOU-501-A113	Detailed BOM/BOQ for crane	INFORMATION	8
15	PE-VO-MOU-501-A202 (5 sheets)	Schematic circuit diagram of a) Protective panel, Main and lighting circuit & BOM b) Main hoist panel & BOM c) Cross Traverse & BOM d) Long Traverse & BOM ; Including earthing diagram.	APPROVAL	5
16	PE-VO-MOU-501-A203 (5 sheets)	General Arrangement of a) Protective panel b) Main hoist panel c)Cross Traverse panel d) Long Traverse traverse panel. e) Pendent f) Remote Radio Control.	INFORMATION	5
17	PE-VO-MOU-501-A204	Cable Sizing and cable schedule	APPROVAL	6
18	PE-VO-MOU-501-A205	Crane Operational write up	INFORMATION	5
19	PE-VO-MOU-501-A206	Type test certificate (for motors) , if applicable	APPROVAL	6
20	PE-VO-MOU-501-A250	Mandatory spare parts list (if applicable)	APPROVAL	8
21	PE-VO-MOU-501-A251	O & M Manual	INFORMATION	10
22	PE-VO-MOU-501-A252	Sea worthy packing(if applicable)	INFORMATION	8
23	PE-VO-MOU-501-A253	Erection procedure	INFORMATION	8



Technical specification  
for Double girder EOT cranes for BFP, Sea  
water Intake pump house  
( Up to 50T Cap.)  
2x660 MW SEZ ENNORE STPP

Spec no:- PE-TS-412-501-A101

VOLUME III

SECTION -D

Rev 00

13.05.15

Notes:

1. The above drawing list is tentative and shall be finalized with the successful bidder after placement of order. While some of the drawings indicated above may not be applicable, some additional drawings may also be required based on scope of work.
2. Drawings shall be prepared in Auto-Cad latest edition. Required no. of hard and soft copies (editable) of the drawings shall be furnished as per requirement specified elsewhere in the specification.
3. Only manual calculation with authentic supporting literature (e.g. extracts of hand Book/ standard/codes) shall be acceptable. All design calculations and drawings shall be in SI system only.
4. Bidder to note that all values/dimensions/elevations etc. without supporting back up data adopted/assumed by the successful bidder (during contract stage) in the design calculation/drawings shall be taken by the customer/owner to be correct unless they are stipulated in the specification. Any problem arising later in this regard shall be made good by the successful bidder at his cost and no extension of time shall be granted for the same.
5. All the drawings and documents including general arrangement drawing, data sheet, calculation etc. to be furnished to the customer during detailed engineering stage shall include / indicate the following details for clarity w.r.t. Inspection, construction, erection and maintenance etc.:-
  - a) All drawings and documents shall indicate the list of all reference drawings including general arrangement.
  - b) All drawings shall include / show plan, elevation, side view, cross - section, skin section, blow - up view; all major self-manufactured and bought out items shall be labeled and included in BOQ / BOM in tabular form.
  - c) Painting schedule shall also be made as a part of general arrangement drawing of each equipment / items indicating at least 3 trade names.
  - d) All the drawings required to be furnished to customer during detailed engineering stage shall include technical parameters, details of paints and lubrication, hardness and BOQ / BOM in tabular form indicating all major components including bought out items and their quantity, material of construction indicating its applicable code / standard, weight, make etc.
  - e) Drawings/ documents to be submitted for purchasers review/ approval shall be under Revision A, B, C... etc. while drawings /documents to be submitted thereafter for customer's approval after purchaser's approval shall be under R-0, 1, 2, 3 ....etc.
6. Drawings and documents not covered above but required to check safety of machines/ system, shall be submitted during detailed engineering stage without any commercial implication.
7. All drawings shall include "B.O.M" and indicate quantity, material of construction, make along with IS/BS No., Technical parameters, dimensions, hardness, machining symbol and tolerance, requirement of radiography and hydraulic tests, painting details, elevation, side view, plan, skin section and blow-up view for clarity.
8. All drawings shall be prepared as per BHEL's title block and shall bear BHEL's drawing No.
9. Schedule of drawings submissions, comment incorporations & approval shall be as stipulated in the specifications. The successful bidder shall depute his design personnel to BHEL's/ Customer's/ Consultant's office for across the table resolution of issues and to get documents approved in the stipulated time.
10. Bidder to follow the following the drawing submission schedule:
  - 1st submission of drawings from date of LOI as per the submission schedule.
  - Every revised submission incorporating comments – within 7 days.
  - Bidder to submit revised drawings complete in all respects incorporating all comments. Any incomplete drawing submitted shall be treated as non-submission with delays attributable to bidder's account. For any clarification/ discussion required to complete the drawings, the bidder shall himself depute his personal to BHEL for across the table discussions/ finalizations/ submissions of drawings.



Technical specification  
for Double girder EOT cranes for BFP, Sea  
water Intake pump house  
( Up to 50T Cap.)  
2x660 MW SEZ ENNORE STPP

Spec no:- PE-TS-412-501-A101

Volume-II B

Section-C

## Annexure-v

## Drawings/Documents submission

<b>S. NO.</b>	<b>DESCRIPTION OF MANUALS</b>	<b>NO OF PRINTS (sets)</b>	<b>NO. OF CD- ROMs (sets)</b>
1.	PLANT DEFINITION MANUAL-	-	3 CD-ROMs
2.	Drawings "FOR APPROVAL"	10	Soft Copy
3.	Drawings "FOR INFORMATION"	10	Soft Copy
4.	Drawings "FINAL APPROVED DRAWING"	8	Soft Copy
5.	Drawings "AS BUILT "	8	3 CD-ROMs
6	DATASHEETS,DESIGNCALCULATI ONS,PURCHASE SPECIFICATIONS, etc. and Other type of documents		
	i) For Approval	10	SOFT COPY
	ii) FINAL	8	3 CD-ROMs -
	iii) Analysis reports of equipment/ piping/ structures components/ systems employing software packages as detailed in the specifications		
	a) Input	10	SOFT COPY
	b) Output	10	SOFT COPY
	c) Drawings/ Sketches	10	SOFT COPY
7	Erection manual "FINAL"	8	3CD ROMS
8	Operation & Maintenance manual	10	3CD ROMS



Technical specification  
for Double girder EOT cranes for BFP, Sea  
water Intake pump house  
( Up to 50T Cap.)  
2x660 MW SEZ ENNORE STPP

Spec no:- PE-TS-412-501-A101

Volume-II B

Section-C

S. NO.	DESCRIPTION OF MANUALS	NO OF PRINTS (sets)	NO. OF CD- ROMs (sets)
9	Manufacturing QPs, Field QPs, Field welding schedules and their reference documents like test procedures, WPS, POR etc.		
	(i) For review/comment	3	
	(ii) For final approval	4	1 set CD ROMS
10	Welding Manual, Heat Treatment Manuals, Storage & preservation manuals	4	
	Final	4	2 CD ROMS
11	Monthly Vendor Approval and QP approval status	2	1 CD ROM1
12	QA Documentation Package for items / equipment manufactured and dispatched to site	2	2 CD ROMS
13	QA Documentation Package for field activities on equipment/systems at site	2	2 CD ROMS

# **SITE STORAGE AND PRESERVATION GUIDELINES**

## **FOR**

### **MECHNANICAL BOPs**

(Doc No: PE-DC-SSG-A001 REV.00)



**PROJECT ENGINEERING MANAGEMENT, POWER SECTOR**  
**BHARAT HEAVY ELECTRICALS LIMITED-NOIDA**

## ANNEXURE-VI

### CONTENT

- 1 SCOPE OF THE DOCUMENT
- 2 PURPOSE OF STORAGE & PRESERVATION
- 3 MEASURES TO BE TAKEN FOR STORAGE AND PRESERVATION
  - a) GENERAL STORAGE REQUIREMENTS
  - b) GENERAL PRESERVATION REQUIREMENTS
  - c) GENERAL INSPECTION REQUIREMENTS
- 4 TYPE OF STORAGE FOR VARIOUS EQUIPMENT
5. CONCLUSION
6. STACKING ARRANGEMENT FOR PLATES AND STRUCTURAL STEEL

## **1. SCOPE OF THE DOCUMENT**

This guideline is prepared in intent to provide proper site storage and preservation of the Mechanical, Electrical and C & I items / equipment supplied under various bought out packages/items. This storage procedure shall be followed at different power plant sites by concerned agency for storage and preservation from the date of equipment received at site until the same are erected and handed over to the customer.

## **2. PURPOSE OF STORAGE & PRESERVATION**

Many of the items may be required to be kept in stores for long period. It shall therefore be essential that proper methods of storage and preservation be applied so that items do not deteriorate, loose some of their properties and become unusable due to atmospheric conditions and biological elements.

## **3. MEASURES TO BE TAKEN FOR STORAGE, HANDLING & PRESERVATION**

### **a) GENERAL STORAGE REQUIREMENTS**

1. To the extent feasible, materials should be stored near the point of erection. The storage areas should have adequate unloading and handling facilities with adequate passage space for movement of material handling equipment such as cranes, fork lift trucks, etc. The storage of materials shall be properly planned to minimise time loss during retrieval of items required for erection.
2. The outdoor storage areas as well as semi-closed stores shall be provided with adequate drainage facilities to prevent water logging. Adequacy of these facilities shall be checked prior to monsoon.
3. The storage sheds shall be built in conformity with fire safety requirements. The stores shall be provided with adequate lights and fire extinguishers. 'No smoking' signs shall be placed at strategic locations. Safety precautions shall be strictly enforced.
4. Adequate lighting facility shall be provided in storage areas and storage sheds and security personnel positioned to ensure enforcement of security measures to prevent theft and loss of materials.
5. Adequate number of competent stores personnel and security staff shall be deployed to efficiently store and maintain the equipment / material.
7. The equipment shall be stored in an orderly manner, preserving their identification slips, tags and instruction booklets, etc., required during erection. The storage of materials shall be equipment-wise. Loose parts shall be stored in sheds on racks,

preserving the identification marks and tags in good condition. The group codes shall be displayed on the racks

6. At no time shall any materials be stored directly on ground. All materials shall be stored minimum 200 mm above the ground preferably on wooden sleepers

**b) GENERAL PRESERVATION REQUIREMENTS**

1. All special measures to prevent corrosion shall be taken like keeping material in dry condition, avoiding the equipment coming in contact with corrosive fluid like water, acid etc.
2. Materials which carry protective coating shall not be wrapped in paper, cloth, etc., as these are liable to absorb and retain moisture. The material shall be inspected and in case of signs of wear or damages to protective coating, that portion shall be cleaned with approved solution and coated with an approved protective paint. Complete record of all such observations and protective measures taken shall be maintained.
3. Generally equipment supplied at site are properly greased or rust protective oil is applied on machined/ fabricated components. However periodic inspection shall be carried out to ensure that protection offered is intact.
4. While handling the equipment, no dragging on the ground is permitted. Avoid using wire rope for lifting coated components. Use polyester slings (if possible) otherwise protective material (e.g. clothes, wood block etc.) should be used while handling the components with rope / slings
5. For Equipment supplied with finished paint, touch paint shall be done in case any surface paint gets peeled off during handling. Otherwise such surfaces shall necessarily be wrapped with polythene to avoid any corrosion. Further for equipment wherein finish coat is to be applied at site, site to ensure that equipment is received with primer coat applied.
6. It shall be ensured by periodic inspection that plastic inserts are intact in tapped holes, wherever applicable.
7. Pipes shall be blown with air periodically and it shall be ensured that there is no obstruction.
8. Silica gel or approved equivalent moisture absorbing material in small cotton bags shall be placed and tied at various points on the equipment, wherever necessary.
9. Heavy rotating parts in assembled conditions shall be periodically rotated to prevent corrosion/jamming due to prolonged storage.

10. All the electrical equipment such as motors, generators, etc. shall be tested for insulation resistance at least once in three months and a record of such measured insulation values shall be maintained.
11. Following preservatives/preservation methods can be used depending upon type of equipment
  - a. Rust preventive fluid (RPF)
  - b. Rust protective paints
  - c. Tarpaulin covers, in case of outdoor storage
  - d. De-oxy aluminate for weld-ments

**c) GENERAL INSPECTION REQUIREMENTS**

1. Period inspection of materials with specific reference to –
  - Ingress of moisture and corrosion damages.
  - Damage to protective coating.
  - Open ends in pipes, vessels and equipment -
    - In case any open ends are noticed, same shall be capped.
2. Any damages to equipment / materials.
  - In case of any damages, these shall be promptly notified and in all cases, the repairs / rectification shall be carried out.
  - Any items found damaged or not suitable as per project requirements shall be removed from site. If required to store temporarily, they shall be clearly marked and stored separately to prevent any inadvertent use.

#### 4. TYPE OF STORAGE FOR VARIOUS EQUIPMENT

The types of storage are broadly classified under the following heads:

i **Closed storage with dry and dust free atmosphere. (C )**

The closed shed can be constructed by using cold-rolled / tubular components for structure and corrugated asbestos sheets / galvanised iron sheets for roofing. Brick walls / asbestos sheets can be used to cover all the sides. The floor of the shed can be finished with plain cement concrete suitably glazed. The shed shall be provided with proper ventilation and illumination.



ii **Semi-closed storage. (S)**

The semi closed shed can be constructed by using cold-rolled / tubular components for structure and corrugated / asbestos sheets for roofing. The floor shall be brick paved. If required a small portion of sides can be covered to protect components from rainwater splashing onto the components.





iii Open storage (O )

The open yard shall be levelled, well consolidated to achieve raised ground with the provision of feeder roads for crane approach along with access roads running all sides. One part of the open yard shall be stone pitched, levelled and consolidated with raised ground suitable for storing / stacking heavier and critical components with due space to handle them by cranes etc . Adequate number of sleepers, concrete block etc. to be provided to make raised platforms to stack critical materials.

A separate yard to be identified as “scrap yard” slightly away from main open yard to store wooden/steel scraps, which are to be disposed off. This is required to avoid mix up with regular components as well as to avoid fire hazard.

Some of the components, which are having both machined & un-machined surfaces and are bulky, shall be stored in open storage area on a raised ground and suitably covered with water proof / fire retardant tarpaulin.



The equipment listed below shall be stored and inspected as per requirement mentioned in the table below.

Sl. No.	Description of the equipment	Type of Storage	Check for	Remarks
<b>Raw material /mechanical items like pipes, plates, structure sections etc.)</b>				
1.	Steel pipes ( lined/unlined)	S	Damage , paint, corrosion, rubber lining peeling	Provide end cap
2.	MS Plates	S	Damage, paint, corrosion	
3.	SS Plates	S	Damage	
4.	Non-metallic pipes	S	Damage, cracks	Provide end cap
5.	Stainless steel pipes	S	Damage ,	Provide end cap
6.	MS sections, beams	S	Damage, paint, corrosion	
7.	Cable trays	S	Damage, condition of preservations	
8.	Insulation sheets	S	Damage	
9.	Insulation	C	Damage, packing	
10.	Hangers Rods	S	Damage, paint, packing	
11.	Tubes	S	Damage, paint , packing	Provide end cap
12.	Hume pipes	O	Damage	
13.	Castings	O	Damage, paint, corrosion	
<b>Fabricated mechanical items (pressure vessels, tanks etc.)</b>				
14.	Pressure vessels (unlined)	O	Damage, paint, corrosion,	Covered nozzles
15.	Atmospheric storage tanks (unlined)	O	Damage, paint, corrosion	Covered nozzles

Sl. No.	Description of the equipment	Type of Storage	Check for	Remarks
16.	Pressure vessels (lined)	S	Damage, paint, corrosion, rubber lining	
17.	Atmospheric storage tanks(lined)	S	Damage, paint, corrosion, rubber lining	
18.	Support structures	O	Damage , paint, corrosion	
19.	Flanges	C	Damage , paint, corrosion	
20.	Fabricated pipes	S	Damage , paint, corrosion	Provide end cap
21.	Vessels internals	C	Damage , paint, corrosion ,packing	
22.	Grills	S	Damage , paint, corrosion	
23.	Angles	S	Damage , paint, corrosion	
24.	Bridge mechanism/clarifier mechanism	O	Damage , paint, corrosion	
25.	Cranes, rails	S	Damage , paint, corrosion	
26.	Stair cases	O	Damage , paint, corrosion	
27.	Ladders/handrails	O	Damage , paint, corrosion	
28.	Fabricated ducts	S	Damage , paint, corrosion	
29.	Isolation Gates	O	Damage , paint, corrosion	
30.	Fabricated boxes/panels	S	Damage , paint, corrosion	
<b>Mechanical components like valves, fittings, cables glands, spares etc.)</b>				
31.	Valves	S	Damage , packing	

Sl. No.	Description of the equipment	Type of Storage	Check for	Remarks
32.	Fittings	S	Damage , packing	Provide end cap
33.	Cable glands	C	Damage , packing	
34.	Tools & tackles	C	Damage , packing	
35.	Nut , bolts, washers,	C	Damage , packing	
36.	Gasket & Packings	C	Damage , packing	
37.	Copper tubes	C	Damage , packing, corrosion	Provide end cap
38.	SS tubing	C	Damage , packing	Provide end cap
<b>Rotating assemblies (pumps, blowers, stirrers, fans, compressors etc.)</b>				
39.	Pumps	S	Damage , packing, corrosion	Shaft rotation
40.	Blowers/Compressors	S	Damage , packing, corrosion	Shaft rotation
41.	Agitators/stirrers/radial launders	C	Damage , packing, corrosion	Shaft rotation
42.	Rollers for chlorine tonner mounting	C	Damage , packing, corrosion	
43.	Centrifuge	S	Damage , packing,	
44.	Gear box	C	Damage , packing, corrosion	
45.	Bearings	C	Damage , packing, corrosion	
46.	Fans	S	Damage , packing, corrosion	
47.	Dosing skids	S	Damage , packing, corrosion	
48.	Pump assemblies	S	Damage , packing, corrosion	
49.	Air washers( INTERNALS)	S	Damage , packing	
50.	Air conditioners ( split)	C	Damage , packing	

Sl. No.	Description of the equipment	Type of Storage	Check for	Remarks
51.	Elevators( CONTAINERIZED)	O	Damage , packing, corrosion	
52.	Chillers/VA machines	S	Damage , packing	
53.	Air handling Unit/Package unit	S	Damage , packing	
54.	Chlorinators & Evaporators	C	Damage , packing	
55.	Ejectors	C	Damage , packing	
56.	Electrolyser	C	Damage , packing	
<b>Miscellaneous items like chain pulley blocks, hoists etc.</b>				
57.	Chain pulley blocks	S	Damage, Packing	
58.	Electric hoists	S	Damage, Packing	
59.	Fire extinguishers	C	Damage, expiry date	
60.	Fork Lift Truck	S	Damage, Packing	
61.	Hydraulic Mobile Crane	O	Damage, Packing	
62.	Mobile Pick Up & Carry Crane	O	Damage, Packing	
63.	Motor boats	O	Damage, Packing	
64.	Safety showers	S	Damage, Packing	
65.	Diffusers/dampers	S	Damage, Packing	
<b>Chemicals and consumables ( acid, alkali, paints, oils, reagents and special chemicals)</b>				
66.	Hydro Chloric Acid (HCl)	Store in canes/ storage tank in dyke area	Date of production/ leakage/fumes	hazardous chemical
67.	Sulphuric acid (H <sub>2</sub> SO <sub>4</sub> )	Store in canes/ storage tank in dyke area	Date of production/ leakage/fumes	hazardous chemical

Sl. No.	Description of the equipment	Type of Storage	Check for	Remarks
68.	Sodium hydroxide (NaOH)	Store in canes/ storage tank in dyke area	Date of production/ leakage/ fumes/ breather	hazardous chemical ,breather to be checked for air ingress
69.	Sodium hypo chlorite	To be stored under shed	Date of production/ leakage/ fumes	hazardous chemical ,self-life normally 15-30 days after which strength of chemical decays
70.	Ammonia	S	Date of production/ leakage/ fumes	Store in closed storage tanks, hazardous chemical
71.	CW treatment chemicals	S	Date of production , Self-life	Store in closed canes
72.	RO/UF cleaning chemicals	S	Date of production , Self-life	Store in closed canes
73.	Lime	C	Damage to packing , seepage	Prevent moisture, rain
74.	Alum bricks	C	Damage to packing	Prevent moisture, rain
75.	Poly electrolyte	S		Store in closed storage tanks
76.	Laboratory chemicals( powder)	C	Damage, Packing self- life	
77.	Laboratory chemicals( liquid)	C	Damage, Packing self- life	
78.	Lubrication oils	C	Leakage	
79.	Paints	S	Leakage ,air tightness	
80.	Sand	O	Damage of packing	No hooks
81.	Salt (NaCl)	C	Damage of packing, water ingress	Prevent moisture, rain
82.	Anthracite	S	Damage of packing	
83.	Activated carbon	S	Damage of packing	

Sl. No.	Description of the equipment	Type of Storage	Check for	Remarks
84.	Thermal insulation	S	Damage of packing	
85.	Cement	C	Damage of packing	Prevent moisture, rain
86.	Gravels	O	Damage of packing	
87.	ION exchange resins	C	Damage , packing	Refer manufacturer guidelines
88.	RO membranes	C	Damage , packing	Refer manufacturer guidelines
89.	UF membranes	C	Damage , packing	Refer manufacturer guidelines
90.	Cleaning chemicals	C	Damage , packing	Refer manufacturer guidelines
91.	Chemicals for analysers/calibration	C	Damage , packing	Refer manufacturer guidelines
<b>Electrical and C &amp; I items (motors, cables etc.)</b>				
92.	Motors	C	Damage , packing	
93.	Cable drums	O	Damage	
94.	Control Panel /control desk, UPS ,JB	S	Damage, Packing	
95.	Instruments( gauges/analysers)	C	Damage	
<b>Special items</b>		As per Manufacturer's item, like Hydrogen cylinders, Ozonator, Analyser, Chlorine dioxide generators etc.		

## **5. CONCLUSION**

Concerned storage agency at site should make sure that loss in equipment performance and wear & tear are minimised through proper storage and preservation. The above are broad guidelines and cover major equipment / materials. However specific storage practices shall be followed as per manufacturer recommendation. All the necessary measures even in addition to the ones mentioned above, if found necessary, should be taken to achieve the objective.

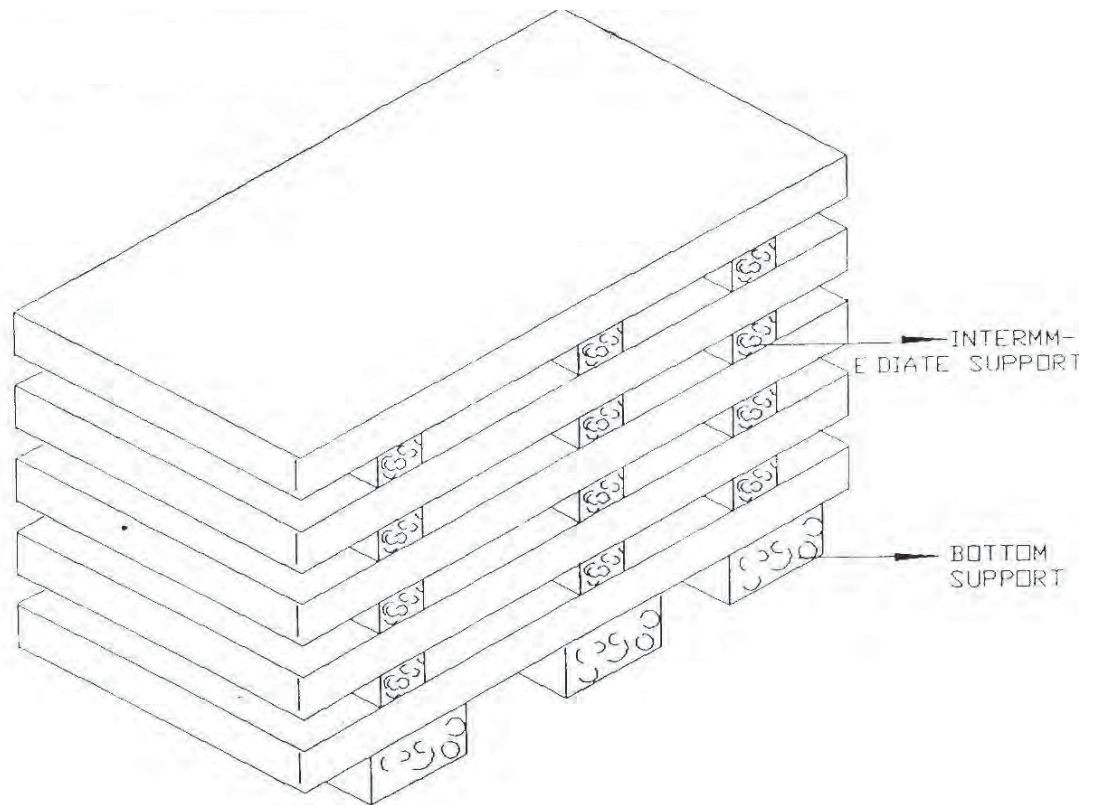

Figure - 1 - PLATE STACKING ARRANGEMENT

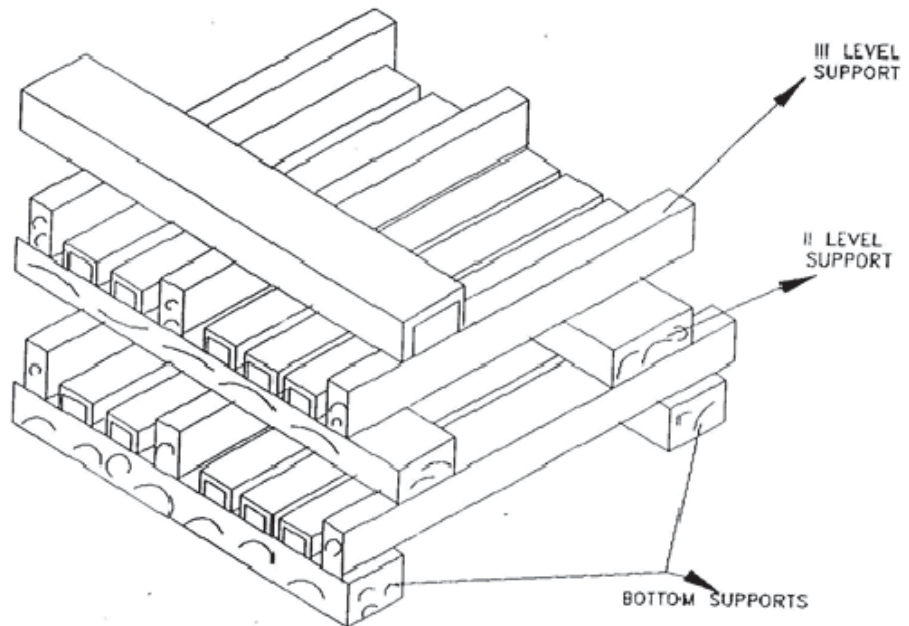

Figure - 2 - STRUCTURAL STEEL STACKING ARRANGEMENT



**TITLE**

**Technical Specification for**  
Double girder EOT cranes for BFP,Sea  
Water intake pump house (Up to 50TCap)  
**STANDARD TECHNICAL SPECIFICATION**

SPECIFICATION NO. PE-TS-412-501-A101

VOLUME: II B

REV 00

Section D

June 2015

Page 1 of 23

**VOLUME - IIB**

**SECTION – D**

**STANDARD TECHNICAL REQUIREMENTS**



TITLE

**Technical Specification for**  
Double girder EOT cranes for BFP,Sea  
Water intake pump house (Up to 50TCap)  
**STANDARD TECHNICAL SPECIFICATION**

SPECIFICATION NO. PE-TS-412-501-A101

VOLUME: II B

REV 00

Section D

June 2015

Page 2 of 23

## DOUBLE GIRDER EOT CRANE

### 1.0.0 SCOPE

This specification covers the design, material, manufacture, assembly, inspection and testing at manufacturer works for EOT cranes and shall be applicable unless the requirements are addressed otherwise in BHEL / BHEL's Customer approved documents.

### 2.0.0 CODES AND STANDARDS

The equipment to be supplied under this specification shall conform to the following codes and standards (latest revisions) unless otherwise specified hereinafter.

- |       |                  |   |
|-------|------------------|---|
| i)    | IS 807           | Codes of Practice for Design, Manufacture, Erection and Testing (Structural Portion) of cranes and hoists |
| ii)   | IS: 3177         | Code of Practice for Design of Overhead Travelling Cranes and Gantry Cranes other than steel work cranes. |
| iii)  | IS: 2266         | Specification for steel wire ropes for general Engineering purposes.                                      |
| iv)   | IS: 4029         | Guide for testing induction motor (for temperature rise).   |
| v)    | IS: 15560        | Steel hooks for standard shank design.  |
| vi)   | IS: 3443         | Specification for crane rail section.   |
| vii)  | IS: 325          | Three phase induction motors.   |
| viii) | IS: 900          | Code of practice for installation and maintenance of induction motors.                                    |
| ix)   | IS: 4237         | General requirement of switchgear and Control gear for voltage not exceeding 1000V.                       |
| x)    | IS: 434 (Part I) | Copper conductors rubber insulated cables for voltage up to 1000V.  |
| xi)   | IS 1596          | Polyethylene insulated PVC sheathed cables  |
| xii)  | IS 3043          | Code of practice Earthing   |
| xiii) | IS: 3938         | Electric Wire Rope Hoists.  |
| xiv)  | IS: 2147         | Degree of protection provided by enclosures for Low voltage switchgear and control gear.                  |

**TITLE**

**Technical Specification for**  
Double girder EOT cranes for BFP,Sea  
Water intake pump house (Up to 50TCap)  
**STANDARD TECHNICAL SPECIFICATION**

SPECIFICATION NO. PE-TS-412-501-A101

VOLUME: II B

REV 00

Section D

June 2015

Page 3 of 23

- |         |                   |   |
|---------|-------------------|---|
| xv)     | IS: 1554 Part I   | PVC insulated (Heavy-duty) electric cables for working voltages up to and including 1100 volts.             |
| xvi)    | IS: 691           | Flexible trailing cables rubber insulated.  |
| xvii)   | IS: 1653          | Steel conduits for general engineering purposes.  |
| xviii)  | IS: 2509          | Rigid non-metallic conduit for electric- Installations  |
| xix)    | IS: 2062          | Steel for General Engineering purposes.   |
| xx)     | IS: 1030          | Carbon Steel castings for general engineering purposes.   |
| xxi)    | IS: 1570          | Schedules for Wrought steels.   |
| xxii)   | IS: 1875          | Carbon steel billets, blooms, slabs and bars for forgings.  |
| xxiii)  | IS: 808           | Dimensions for hot rolled steel beam, column, channel and angle sections.                                   |
| xxiv)   | IS: 1852          | Rolling and cutting tolerances for Hot rolled steel products.   |
| xxv)    | IS: 2291          | Tangential Keys and Keyways.  |
| xxvi)   | IS: 2292          | Taper Keys and Keyways.   |
| xxvii)  | IS: 3961          | Recommended current rating for cables.  |
| xxviii) | IS: 694           | PVC insulated cables for working voltages up to and including 1100V)  |
| xxix)   | IS: 1554 (part-I) | PVC insulated (heavy duty) electric cables:<br>Part 1: for working voltages up to and including 1100 volts. |
| xxx)    | IS: 4289          | Flexible cables for lifts and other flexible connections: Part 1: Elastomer insulated cables.               |
| xxxi)   | BS: 970           | Wrought steels in the form of blooms, billets, bars and forgings.   |
| xxxii)  | IS: 5749/ BS 3017 | Specification for Forged Rams horn Hooks  |

**Indian electricity rules - 1956.**

In the event of any conflict between the specification and standards mentioned above, the more stringent of the two as per interpretation of purchaser shall govern.

**TITLE**

**Technical Specification for**  
Double girder EOT cranes for BFP,Sea  
Water intake pump house (Up to 50TCap)  
**STANDARD TECHNICAL SPECIFICATION**

SPECIFICATION NO. PE-TS-412-501-A101

VOLUME: II B

REV 00

Section D

June 2015

Page 4 of 23

**3.0.0 DOUBLE GIRDER EOT CRANE****3.1.0 DESIGN REQUIREMENTS**

3.1.1 The crane shall be designed in accordance with the latest edition of IS-3177, IS-807 and any other standard as referred there in and subject to any modification and requirement as specified herein after.

Class of crane mechanism shall correspond to that of the crane requirement and as specified elsewhere.

3.1.2 Safety devices should be provided with all equipment/parts covered under this specification.

3.1.3 Parts requiring replacement or lubrication shall easily be accessible without dismantling the other equipment or structures. All electrical cables shall be laid to comply with recognized standards and purchaser's requirements.

3.1.4 For welded construction such as bridge girders, end carriages, rope drum, gearboxes etc. steel shall be conforming to IS-2062 quality. Welding shall be carried out only by qualified welders and subjected to NDT as specified in Quality Plan.

a. Welding shall be performed by shielded electric arc, gas or other approved methods. The electrodes used for welding shall conform to AWS A5.1.

b. Wherever lateral welding of the main plates of box girders are required, it shall be butt-welded.

c. Qualification of welding procedure and welder: These shall be carried out as per ASME Boiler and Pressure vessel code Sec. IX - Welding and brazing qualifications.

d. Electrode designations and qualifications shall be as per AWS A 5.1.

e. Electrodes should be of radiography quality with heavy covering as per IS: 814 and relevant requirement of ASME Sec IX and IIC.

f. Bare electrodes as per IS: 7280 and flux wire combination as per IS: 3613.

3.1.5 No cast iron part shall be used on the crane and its accessories.

3.1.6 Guard shall be provided on crane to prevent the hoist ropes coming in contact with down shop leads.

Guards/ rail sweep of an approved design, which will push forward or off the track any object such as a person foot or arm, placed across it. Guards shall be attached to each end of the end carriages.

Suitable guards shall be provided to revolving shafts, coupling etc.



TITLE

**Technical Specification for**  
Double girder EOT cranes for BFP,Sea  
Water intake pump house (Up to 50TCap)  
**STANDARD TECHNICAL SPECIFICATION**

SPECIFICATION NO. PE-TS-412-501-A101

VOLUME: II B

REV 00

Section D

June 2015

Page 5 of 23

- 3.1.7 All cables shall be clamped individually. All trailing cables shall be clamped with PVC or non-metallic clamp.
- 3.1.8 Walkways of CT shall be of chequered plate minimum 6 mm thick O/P at least 800 mm clear inside with non-skid toe plates 8mm thick, projecting 100 mm above the floor. Walkways shall be of rigid construction and designed to sustain a distributed load of not less than 300 kg/ sq. mm.  
Intermediate posts for supporting handrails shall not be spaced more than 1.5 meters apart.  
Ladders provided shall have at least 450mm clear width with 20 mm rungs (rods) spaced 300 mm apart.
- 3.1.9 All wheels, couplings, open gear etc. shall be provided with covers.
- 3.1.10 All bolts except those with locknut shall be provided with grip lock nuts or spring washers.
- 3.1.11 Fasteners for pedestal blocks, motors, gearboxes etc. shall be easily removable from the top. Studs shall not be used as fasteners for mechanical items except for fixing covers.
- 3.1.12 Defects in the material like fractures, cracks, blowholes, pitting etc. are not allowed. Rectification of any such flaw is permissible only with the approval of the purchaser.
- 3.1.13 All parts of the crane shall be thoroughly cleaned of mill scales, rust or foreign matter and then painted as per the specification requirements.  
The permissible camber shall be shown in drawing or data sheet submitted for approval.
- 3.2.0 **STRUCTURAL DETAILS**
- 3.2.1.0 Crane structure shall be designed in accordance with the latest edition of IS-807 after taking the following additions/deviations as applicable.
- 3.2.1.1 Black bolts shall not be used in the main structure of the crane. The calculated strength of other bolted joints in structural members shall not be less than net strength of member plus 25%.
- 3.2.1.2 The calculated strength of riveted joint or joints made by friction grip bolts in structure members shall be not less than the calculated net strength of the member.
- 3.2.1.3 Bolts used in shear shall be fitted in to reamed hole.
- 3.2.1.4 Nuts and Bolts will be as per IS:1363, IS: 1364 and IS: 1367  
High-tension friction grip bolts as per IS: 3757 and High-tension friction grip nuts as

**TITLE**

**Technical Specification for**  
Double girder EOT cranes for BFP,Sea  
Water intake pump house (Up to 50TCap)  
**STANDARD TECHNICAL SPECIFICATION**

SPECIFICATION NO. PE-TS-412-501-A101

VOLUME: II B

REV 00

Section D

June 2015

Page 6 of 23

per IS: 6623

- 3.2.1.5 Transverse filled welding on load carrying member shall be avoided.
- 3.2.1.6 All butt welds on structural members subjected to tensile stress shall be of radiographic quality as ASME Sec VIII Div.1 acceptance norms.
- 3.2.1.7 Fillet welding on load carrying members shall be avoided.
- 3.2.1.8 For load carrying members the component plates, bars, angles and other rolled sections shall be minimum 8mm thick. For tubes having both ends sealed the minimum thickness shall be 4.9 mm (6 SWG). For unsealed tubes the minimum thickness shall be 8mm.
- 3.2.1.9 The cranes working out door or in corrosive environment, an allowance of 1.5 mm shall be added to the calculated thickness.
- 3.2.1.10 Minimum thickness of chequered plates for platform shall be over 6 mm over plain. Chequered plates shall not be considered for strength calculations of load carrying members.
- 3.2.1.11 Splice shall be designed to resist all the forces and moments to which it is subjected to plus 50% thereof.
- 3.2.1.12 However, in no case the strength developed by the splice shall be less than 50% of the effective strength of the material spliced. Splices shall be proportioned and arranged, so that the gravity axis of the splice in line with the gravity axis of the member joined so as to avoid the eccentricity of the loading.
- 3.2.1.13 The material of construction of the major components shall be as specified in the specification/data sheet. Manufacturer are however free to use alternate material material which are superior for the intended service. But in all the cases, prior concurrence of the purchaser is must.
- 3.2.1.14 Splices shall be designed to resist one and half times the forces and moments to which it is subjected, but in no case it shall be less than 2/3rd of the effective strength of the material spliced except that splices in the webs of the plate girders shall be designed for full strength of the web in shear as well as bending. For splicing tension members, the net section of the splice plate shall be ten percent more than that of the material spliced. Splices shall be proportioned and arranged, so that the gravity axes of the splices are in line with the gravity axis of the member to avoid eccentricity.

3.2.2 **Bridge Girder**

**TITLE**

**Technical Specification for**  
Double girder EOT cranes for BFP,Sea  
Water intake pump house (Up to 50TCap)  
**STANDARD TECHNICAL SPECIFICATION**

SPECIFICATION NO. PE-TS-412-501-A101

VOLUME: II B

REV 00

Section D

June 2015

Page 7 of 23

- 3.2.2.1 The bridge girder shall consist of a box construction with double Web plate girders or lattice girders and shall be of adequate strength to withstand the rolling loads and other stresses it is subjected to.. The design of the girder shall be in accordance with latest edition of IS- 807.
- 3.2.2.2 Maximum deflection of the bridge girder, with safe working load, shall not exceed 1/900 of the span or as per latest IS. The girder shall be supported on the centerline of LT wheels during the deflection check. The girder shall be cambered by an amount by an amount equal to the maximum deflection.
- 3.2.2.3 Box section shall be adequately reinforced by internal diaphragms and ribs to withstand the most severe combination of load that may develop under different working conditions. Additional Internal diaphragms shall be provided at points where external members are welded for providing support to drives etc.
- 3.2.2.4 Box girders shall be provided with end plates sealing. Diaphragms inside the girder shall extend to the full - width & depth of the girder and the web plates shall be reinforced by angles all along the full length of the plates spaced midway between the diaphragms. Full depth diaphragms or stiffeners shall be furnished at bridge drive supports and below the line shaft bearings.
- 3.2.2.5 Short diaphragms shall be furnished and are required to transmit the trolley wheel loads to the web plates. Trolley rail section shall not be considered into design of bridge girders.
- 3.2.2.6 Full length chequered platforms on both side shall be provided on the side of bridge girders as specified in data sheet - A.
- 3.2.2.7 There should not be accumulation of water/oil inside the box girders. If required breathing holes can be provided for expansion / contraction, due to change in temperature. Tapped (threaded) holes shall be provided with ½” NPT plug in the bottom of the girders, at both ends, to drain off any accumulation of water / Oil inside the girder. Instruction shall be painted on the girders to remove the plug and check for water/oil before lifting. Plug shall be replaced after installation.
- 3.2.2.8 All connection splices shall be designed for full strength of member of loads indicated unless otherwise approved. Beams and connections shall be designed for 60% of shear capacity of beam section plus additional axial load if any. Not more than one splice shall be provided to make up full length of number.
- 3.2.2.9 Maximum Span/ Depth ratio for Girder

**TITLE**

**Technical Specification for**  
Double girder EOT cranes for BFP,Sea  
Water intake pump house (Up to 50TCap)  
**STANDARD TECHNICAL SPECIFICATION**

SPECIFICATION NO. PE-TS-412-501-A101

VOLUME: II B

REV 00

Section D

June 2015

Page 8 of 23

- Plate Girder: 18
- Lattice Girder : 12

**3.2.3 End carriage**

3.2.3.1 End carriages shall be fabricated from rolled steel section or plates. End carriage shall be of ample strength to resist all stresses likely to be imposed on them under service conditions including collision with other cranes or stops. The length of the end carriages shall be such that no other part of the crane is damaged in collision. End carriage shall be so designed as to distribute the load evenly between the wheels from each bridge girders.

3.2.3.2 The wheel base shall not be less than 1/5th of the span. End carriage shall be fitted with safety stop to prevent the end carriage falling more than 25 mm in the event of breakage of a track wheel, bogies or axle.

3.2.3.3 Suitable jacking pads at a suitable height from rail level shall be provided on each crane for crane jacking. Jacking pad dimensions shall be suitable for full seating of the jacking pad seat without any instability. When changing the track wheel, jacking pads shall not interfere with replacement of track wheel.

**3.2.4 Crab (Trolley)**

3.2.4.1 The crab frame shall be built from heavy steel section, welded properly to form single piece frame & to resist vertical, lateral and torsional strain and to support all loads without undue deflection. It should be properly machined to receive hoisting mechanism, cross traverse arrangement/mechanism, wheels etc. etc.

3.2.4.2 Sheaves, part of hoisting mechanism, shall be so arranged on trolley that rope reeling arrangement shall ensure lifting of load in vertical line with minimum of swing or side movement. Trolley shall be provided with chequered plates all over except for opening required for ropes and equipment foundation. Equipment foundation shall not be welded/ supported on chequered plates. Toe plates 100 mm high and 6mm thick shall be provided around opening provided for movement of ropes. Suitable railing shall also be provided around the opening for rope in case the opening is large.

**3.2.4.3 Platforms and Ladders**

a) Safe means of access shall be provided to every place where any person engaged in the examination or maintenance of the crane has to work. Adequate handholds and footholds shall be provided as necessary..



TITLE

**Technical Specification for**  
Double girder EOT cranes for BFP, Sea  
Water intake pump house (Up to 50T Cap)  
**STANDARD TECHNICAL SPECIFICATION**

SPECIFICATION NO. PE-TS-412-501-A101

VOLUME: II B

REV 00

Section D

June 2015

Page 9 of 23

b) Every platform shall be provided with steel chequered plate top and be securely fenced with 1050 mm high double tier hand rails and toe boards. Platforms shall be of sufficient width to enable normal maintenance work to be undertaken safely

c) Safety hand railing of tubular construction 32 mm NB Medium class of IS: 1239 having top and bottom rail at height of 1100 mm and 600 mm and vertical post spacing not exceeding 1750 mm with provision of kick plate (100 mm high and 6mm thick) shall be provided on bridge walkways and on end carriages, staircases, trolley and at any other place where access is provided. Bends shall be neat and made by machine. The top rail should be so laid that there is no intermediate obstruction and hand need not be lifted from rail while walking

d) In case lattice riveted construction is offered for the bridge girder, full length chequered plate platform with adequate headroom shall also be provided at bottom chord level for periodic checking of all rivets/bolts and other items.

3.2.5.0 Brief description of crane operation, Maintenance and periodical lubrication etc. typed in English and in local language neatly framed in a permanent frame for easy reference.

3.2.6.0 Suitable inspection cages to accommodate two persons to facilitate inspection of DSL.

### 3.3.0 **MECHANICAL**

#### 3.3.1 **Rope drums**

Rope drums shall be of mild steel plate fabricated/ cast steel/ as per IS 3177. All fabricated rope drums shall be stress relieved. The drum shall be so designed to take full length of hoisting rope in single layers. The end of the rope shall be anchored to the drum in such a way that the charger is readily accessible. Each rope shall have not less than two (2) full turns on the drum when the hook is at lowest position not taking into consideration the turns covered by the rope in charge. One spare groove shall be provided for each rope drum when the hook is at the highest position. Each rope end shall be clamped with minimum two clamping wedges with at least two bolts on each clamping arrangement.

The pitch diameter of the drum shall be as per IS - 3177 or as specified elsewhere. The depth of the groove shall not be less than 0.35 times the rope diameter. Each rope shall be clamped to drum with two clamp wedges with at least two numbers of bolts on each clamping arrangement.



TITLE

**Technical Specification for**  
Double girder EOT cranes for BFP,Sea  
Water intake pump house (Up to 50TCap)  
**STANDARD TECHNICAL SPECIFICATION**

SPECIFICATION NO. PE-TS-412-501-A101

VOLUME: II B

REV 00

Section D

June 2015

Page 10 of 23

For evaluation of Radiography the designed thickness of the drum (top of crest to ID) shall be taken into consideration and not the thickness of plate selected.

### 3.3.2 Hoist ropes

Ropes of steel core as specified in Data sheet" A" shall be of 6x36 or 6x37 construction of extra flexible plough steel as per IS 2266 having minimum UTS of 1770 kN.

### 3.3.3 Rope sheaves

Sheaves shall be of cast (Castings to IS: 1030 Gr. II with Y.P. greater than 50% of UTS) or forged steel. All sheaves shall be identical, however, exception may be made for equalizer sheave. Sheave groove shall be ground finished for getting increase rope life. Equalizer sheave shall be arranged to turn and swivel in order to maintain rope alignment under all circumstances.

### 3.3.4 Wheels

LT & CT wheels shall be double flanged with straight tread. The wheels shall be capable of taking up misalignment in span as specified. Solid wheel shall either be of forged steel or as specified in Data sheet. The wheel rim shall be with minimum hardness of BHN 300-350. Wheels may be either hardened on tread portion as per IS -3177 or Volume hardened. Contact stresses between wheels and rails should be within permissible limits.

### 3.3.5 Buffer

Each End carriage shall be provided with buffer as per data sheet 'A'. Buffers should be so located that removal is not required while changing wheels or bogies. Buffers shall have sufficient tension on energy absorption capacity to bring the unloaded crane to rest from the speed of 100% of the rated speed to zero speed. Buffer is to be fitted to each end of carriage assembly and crab so that buffer contact takes place before the bridge or trolley reaches the end of rail.

### 3.3.6 LT drive

The bridge motion shall be achieved by suitable drive arrangement as specified elsewhere. When twin drives are used, these shall be operating in unison to avoid skewing effect. The drives shall be interlocked for simultaneous starting, stopping & speed control.

### 3.3.7 CT drive



TITLE

**Technical Specification for**  
Double girder EOT cranes for BFP,Sea  
Water intake pump house (Up to 50TCap)  
**STANDARD TECHNICAL SPECIFICATION**

SPECIFICATION NO. PE-TS-412-501-A101

VOLUME: II B

REV 00

Section D

June 2015

Page 11 of 23

Trolley drive shall be achieved by suitable drives & power shall be transmitted to the geared wheel by means of pinions mounted on both ends of the output shaft.

### 3.3.8. **Gearing**

3.3.8.1 Gears in speed reducer unit for bridge drive, hoists and trolley drive gearing shall be enclosed in substantial housing and shall operate in oil bath. The housing shall be of sufficient design not to permit temperature in excess of 90°C for the oil bath. Spur and helical gearing shall normally be used for all motions. Worms and bevel gears shall not be used. First high-speed reduction shall be through helical gears. All gears shall be hardened and tempered and of alloy steel with machine cut teeth 1.6 Micron finish or better and lapped with some minimum applied load to remove high spots and to improve tooth contact. Cast alloy steel is acceptable only for gears in the last stage of speed reduction. Surface hardening of teeth is not acceptable. Gear teeth shall preferably be cut in metric module system. Gears shall be designed to meet requirement of crane duty as per IS: 3177. The ratings of gears shall be established as per IS: 4660.

### 3.3.9 **Gear Box**

3.3.9.1 All gears shall be completely covered and enclosed in oil tight casing & sealed with gasket. In case of totally enclosed gearboxes, splash or automatic lubrication system shall be used. Covers shall be split horizontally at each shaft centre line, so that top half can be removed for inspection and repair with out disturbing the bottom half. Gear shafts shall be supported on ball/roller bearings mounted in gearbox unless specially agreed otherwise. The gear boxes shall be provided with breather, air vent, oil level indicator, dip stick, drain plug and lugs for lifting.

Radial clearance between the gear boxes inner surface and outside diameter of the gears shall be at least 1.25 times the depth of larger gear tooth inside the gear box or 20mm which ever in higher. Facial clearance between inner surface of gearbox and face of gear or pinion shall be at least 20 mm. Gearbox shall be inspected in line with QP and as per PEM (Q)/001 enclosed.

3.3.9.2 The gearboxes shall be of mild steel or cast steel. All fabricated gearboxes shall be stress relieved at a temperature between 590 to 680 deg. C. The temperature shall be maintained within  $\pm 20$  deg. C and at no time during the soaking cycle the temperature shall fall below 590 deg. C or exceed 680 deg. C. Soaking shall be done for a period proportionate to 1 (one) hour/ 2.5 cm. of wall thickness.



TITLE

**Technical Specification for**  
Double girder EOT cranes for BFP,Sea  
Water intake pump house (Up to 50TCap)  
**STANDARD TECHNICAL SPECIFICATION**

SPECIFICATION NO. PE-TS-412-501-A101

VOLUME: II B

REV 00

Section D

June 2015

Page 12 of 23

### 3.3.10 **Bearing**

3.3.10.1 Ball and roller antifriction bearing of attached sub-vendor list, make shall be used throughout, except where specified otherwise. Drive side bearing on Hoisting equipment shall be ball / roller bearing type. Rated life of ball and roller bearing shall be not less than total working life as per data sheet-A. Life of bearing shall be calculated in accordance with manufacturer's recommendations.

3.3.10.2 Provision shall be made for service lubrication of all bearings. Lubrication arrangement and clamping shall be done neatly. Bends in pipe shall be done with the help of machine. Bearing enclosures shall be designed as far as practicable to exclude dirt and shall prevent oil leakage. Accessibility should be such that parts may be safely lubricated from the walkway or ladder when the crane is not in motion.

### 3.3.11. **Shafts, Couplings and axles**

*3.3.11.1 Shafts and axles shall be made from solid rolled or forged steel bars and shall have ample strength and rigidity and adequate bearing surface. If shouldered, they shall be provided with fillets of ample radius and /or be tapered to avoid stress concentration.*

Motor shafts shall be connected to gearbox input extension shafts through flexible gear coupling. Solid coupling shall be used for connecting intermediate lengths of long travel shafts. For driving hoist drum full-gear couplings shall be used between hoists drum & hoist gearbox output shaft. Couplings shall be of cast steel/wrought steel conforming to IS: 1030 grade 280-520 and shall be designed to suit service conditions.

3.3.11.2 Self-aligning type gear couplings shall be used between connection shafts to take care of transverse as well as axial movement whenever necessary. Whenever components of considerable amount of inertia are directly mounted on the high-speed shaft (e.g. brake drum, coupling etc.) they shall be balanced statically to minimise vibration.

### 3.3.12 **Repair Cage**

A repair cage shall be provided on the inside of the end carriage for attending the main current collectors. The repair cage shall be adequately sized to accommodate two persons. And guarded for safety and correctly located for the intended service. Suitable access to the cage shall be provided. Repair cage shall be provided at the corner of the crane.



TITLE

**Technical Specification for**  
Double girder EOT cranes for BFP,Sea  
Water intake pump house (Up to 50TCap)  
**STANDARD TECHNICAL SPECIFICATION**

SPECIFICATION NO. PE-TS-412-501-A101

VOLUME: II B

REV 00

Section D

June 2015

Page 13 of 23

### 3.3.13 **Lifting hook**

Standard hooks shall be used unless otherwise specified. These hooks shall conform to the latest edition. All hooks used shall be in normalized condition only.

### 3.3.14 **LIFTING HOOK BLOCK ASSY**

3.3.14.1 Lifting hook block assembly shall be Ram shorn type or approved for capacity greater than 50 Tonnes and point hook with Shank for capacity below 50 Tonnes and shall be of forged steel construction. Hooks shall be manufactured from Blooms, billets, rounds by forging with forging ratio of at least 3:1. Hooks manufactured from plates are not acceptable. All hooks used shall be in normalized condition only. Each hook shall be supported on ball or roller thrust bearing and shall rotate freely.

3.3.14.2 The sheaves of the hook block shall be enclosed in a casing permitting generous lubrication of wire ropes, sheaves and also preventing accidental tapping of hands.

### 3.3.15 **Brakes**

3.3.15.1 Selection and design of brakes shall be such as to meet the requirement. Brakes shall be designed to suit 150% of torque transmitted to the brake drum with full load for hoist motions and 125% of motor rated torque before de-rating for LT/CT motion. Brakes shall be provided as specified in Data Sheet 'A'. Brake drum shall be separately mounted and coupling halves shall not be used as brake drum.

#### i) **SERVICE BRAKE**

Double shoe types & disc type service brakes shall be provided for each motion of the crane as/or as specified in Data Sheet. The service brakes shall apply automatically when power supply to the drive motor is cut off or fails.

#### ii) **HOIST CONTROL**

Hoist motion shall be provided with a self-contained sturdy braking system to control the speed of hoisting as well as lowering motion. The braking system shall be reasonably uniform and effective in all loads at any position.

### 3.4.0 **ELECTRICAL**

3.4.1 The scope of supply shall cover all electrical equipments comprising from Main isolating switch, down shop leads, trolley conductors, current collectors etc.

3.4.1.1 Main Disconnecting/Isolating Switch fuse unit shall be provided at 1.5M above the operating floor level at one end / at both the ends of bay length or in the middle as specified in the data sheet A. Termination of incoming power supply cable to isolating

**TITLE**

**Technical Specification for**  
Double girder EOT cranes for BFP,Sea  
Water intake pump house (Up to 50TCap)  
**STANDARD TECHNICAL SPECIFICATION**

SPECIFICATION NO. PE-TS-412-501-A101

VOLUME: II B

REV 00

Section D

June 2015

Page 14 of 23

switch fuse unit and further cable from switch to down shop leads shall be included in the bidder's scope of work. The switch shall be provided with Power ON Red indication lamp.

3.4.1.2 Run way conductors (Down shop leads) shrouded conductor as specified in the data sheet A shall have four conductors. One of the conductors shall be connected to earth grid for earthing connections of all electrical equipment on the crane and shall be connected to suitable collecting gear of earth conductor. Voltage drop across the down shop leads shall be less than 3 % or specified in data sheet "A". It shall be supplied with brackets. Maintenance cage for DSL shall be provided on crane.

3.4.1.3 The current collectors shall be with adequate current carrying capacity and shall maintain adequate contact pressure. Spacing between current collectors shall be such as to provide sufficient quenching area for sparks coming out of collectors surface. The collector system per conductor shall spring loaded CI/carbon metallic shoes to maintain adequate contact pressure.

3.4.1.4 The cable, supplying power to crane trolley shall be flexible trailing cable as per IS-9968 Part I (latest edition) and mounted on retracting supports (festoon type).

**3.4.2 DRIVE MOTORS**

3.4.2.1 Crane Motors shall be totally enclosed, fan cooled and as per data sheet 'A'. The starting torque of motor shall not be less than 2.25 times the rated torque and pull out torque shall not be less than 275% of the rated full load torque of motor.. In case of VVVF drive system, the creep speed will be achieved through VVVF drives and the motors for Main hoists, CT and LT will be Squirrel cage. Hoisting drive motors shall be provided with antifriction roller / ball bearings on the drive side.

3.4.2.2 Ambient correction factors as well as voltage /frequency correction factors depending up on the ambient temperature and voltage /frequency variation shall be applied to de-rate the motors. The minimum margin of 10% shall be considered over the calculated rating of the motor. The protection class of the motors shall be as IP-55. Motors shall be tested at manufacturer's works in accordance with IS-325/as per agreed Quality plan & Reports shall be submitted for approval. Motors shall comply with the requirement of IS-325 or as per the motor spec.

3.4.2.3 All the motors shall be provided with lifting lugs two earth terminals of adequate size to accept the earthing conductors shall be provided at diametrically opposite points



TITLE

**Technical Specification for**  
Double girder EOT cranes for BFP,Sea  
Water intake pump house (Up to 50TCap)  
**STANDARD TECHNICAL SPECIFICATION**

SPECIFICATION NO. PE-TS-412-501-A101

VOLUME: II B

REV 00

Section D

June 2015

Page 15 of 23

unless specifically designed For higher speeds, motors shall be capable of with-standing 2.5 times the rated speed.

3.4.2.4 Motors shall be painted in line with painting instructions specified in Painting Scheme Annexure IV attached along with the technical specification.

#### 3.4.3 **Limit switches**

The hoist mechanism of the crane shall be provided with rotary type limit switch to open the control circuit & in order to prevent the crane hook from over hoisting and over lowering, one gravity type back up limit switch of hand reset type shall also be provided. This switch will operate in the event of failure of main limit switch. Lever operated limit switches shall be provided at both ends of longitudinal travel and cross traverse. These limit switches shall be self-reset type. The limit switches shall be as per "Data Sheet A"

#### 3.4.4 **Switch**

All switches shall be hand operated; air break, heavy duty, quick make and quick break type. Incoming supply disconnect switch shall be interlocked with panel door so that the same cannot be opened unless the switch is in OFF position. Safety Interlocks-Disconnect Switch-The operating handle of the main/ safety disconnect switch shall be mechanically interlocked with enclosure cover such that the same cannot be opened unless the switch is in OFF position. Main/ safety disconnect switch shall have provision of pad locking in OFF position

#### 3.4.5. **Contactors.**

Contactors shall be suitable for heavy duty, with current rating not less than connected motor full load current. All reversing contactors shall be mechanically and electrically interlocked.

Each contactor shall be provided with three positive acting ambient temp. Compensated thermal overload relay with adjustable setting to suit the motor current. The relay shall be hand reset type, suitable for current. The relays shall be replaceable from front. The main contactor shall be electrically interlocked so that it cannot close unless all the motor overload relays are RESET and all controllers are in OFF position. The main contactor shall be also opened by means of emergency push buttons and hoist limit switches.

#### 3.4.6 **Push button and lamp**



TITLE

**Technical Specification for**  
Double girder EOT cranes for BFP, Sea  
Water intake pump house (Up to 50TCap)  
**STANDARD TECHNICAL SPECIFICATION**

SPECIFICATION NO. PE-TS-412-501-A101

VOLUME: II B

REV 00

Section D

June 2015

Page 16 of 23

Push button shall be spring return type with 2 NO + 2 NC contacts, rated 10A, 240 V AC. Indicating lamps and lens shall be replaceable from front.

### 3.4.7 Protective Panel

3.4.7.1 The electrical protective panel shall be a cubicle fabricated from Cold rolled sheet steel not less than 2.5mm for front & rear & 2mm for side, top & bottom portion with gland plate of 3mm thick with lockable-hinged door. The control cabinet's door shall be interlocked with the operating handles of isolating switches of supply circuits so as to prevent opening of the door when an isolating switch is closed. A device for bypassing the interlock shall also be provided. It shall be dust and vermin proof with degree of protection as IP-52 or as specified in data sheet A. All the equipment inside the panel shall have permanent identification. The panels shall be front connected type with front-hinged door for access to wiring and terminals. Engraved nameplate shall be furnished for all panels and also for the equipment and devices mounted there on.

The following minimum equipment shall be provided.

- a) One triple pole air break type main contactor with thermal overload relay.
- b) One triple pole main line connecting/disconnecting switch.
- c) Emergency push button at convenient height for the operation for interruption of the entire power.
- d) Thermal overload relay for each drive. It shall be ambient temperature compensated and adjustable type.
- e) Contactors, timer and auxiliary contactors.
- f) Portable Lighting Transformer rated for 415/24V.
- g) Lighting Voltage Transformer with fuse 415/24V.
- h) Control transformer with fuses.
- i) Indicating lamps to indicate the live condition of all three phases.
- j) Main supply ON/OFF lamps on the door of the protective panel.
- k) Electrical interlock shall be provided to prevent the main contactor being closed unless all controllers are in OFF position.
- l) Other equipment as per supplier's standard practice. Air break contactors shall conform to category AC-4 duty. The main contacts shall have the rating for 5 Amps or as specified in the data sheet A. The contactor drop off voltage shall be between 45-50% of rated voltage.



TITLE

**Technical Specification for**  
Double girder EOT cranes for BFP, Sea  
Water intake pump house (Up to 50T Cap)  
**STANDARD TECHNICAL SPECIFICATION**

SPECIFICATION NO. PE-TS-412-501-A101

VOLUME: II B

REV 00

Section D

June 2015

Page 17 of 23

- m) All internal wiring shall be identified with numbering rules at both ends as per the relevant wiring diagram.
- n) Each panel shall have internal illumination with fluorescent lamp. The inside of the panel shall be painted white.
- o) Separate terminal blocks shall be provided for terminating circuits of various voltage classes. At least 20% spare terminals for the wire terminations shall be provided in the cabinet.

#### **3.4.8 Starter Panel**

Separate panels shall be provided for CT, LT & hoist motion (Main), with following type of items.

- a) Contactors : AC4 duty for reversing applications  
AC3 duty for non-reversing applications
- b) Switches : AC23 for motor application.  
AC22 for other application
- c) Fuses : HRC
- d) Overload relays: Temperature compensated bi-metallic with single phasing preventer.

#### **3.4.9 MOTOR CONTROL PANEL**

The motor control panels shall be dust and weatherproof to IP-54/55 or as specified in "Data Sheet A" & shall be provided separate for each motion. The panel shall contain minimum the following components.

- a) Switch fuse unit with contacts of adequate rating for each motion.
- b) Thermal overload relay for each drive. These shall be ambient temperature compensated adjustable type.
- c) Contactors, timers and auxiliary contactors.
- d) The panel shall be provided with space heater. The space heater with thermostat shall be located at the bottom of the panel and shall have individual ON/OFF switch.
- e) Terminal blocks shall be stud or snap on type. A protective cover shall be fixed on top of terminal blocks to prevent accidental contact. A minimum of 20% spare terminals shall be provided.
- f) Air break contactors shall be provided for main supply as well as for motors. They shall conform to category AC-4 as per IS-1322. These shall have

**TITLE**

**Technical Specification for**  
Double girder EOT cranes for BFP,Sea  
Water intake pump house (Up to 50TCap)  
**STANDARD TECHNICAL SPECIFICATION**

SPECIFICATION NO. PE-TS-412-501-A101

VOLUME: II B

REV 00

Section D

June 2015

Page 18 of 23

three main contacts and 2 No. & 2 NC auxiliary contacts.

- g) The main contacts shall have the ratings as per duty requirement but auxiliary contact shall be rated for 5 amp 240V AC. The contactor drop off voltage shall be between 45-50% of rated voltage. The contactor coil shall be suitable for 240V AC supply.
- h) The auxiliary contactors shall have 4 No. + 4 NC contacts for control and interlocking purposes. The contacts shall be convertible. The contacts rating shall be suitable for 5 amps at 240 Volts AC.
- i) Adequate protection for overload and short circuit shall be provided for all the three phases of each motor.
- j) Double pole switch fuse unit for control circuit of the contractor 'START (push button and a pilot lamp with the red lens for indicating the contactor "CLOSED" shall be furnished.

**3.4.11 Illumination**

Crane lighting and space heating system shall be designed for 240V, 1Phase 50Hz supply and receptacle system with 24V 1Phase 50Hz supply or as specified in the Data sheet A. Suitable dry type transformers shall be furnished for this purpose, complete with isolation facility and Primary/secondary fuses.

- a) Branch Circuits for lighting and receptacles shall be individually protected by switch fuse units.
- b) CFL fixtures shall be used for lighting on bridge platform.
- b) 60W bulkhead fittings with fluorescent lamp shall be used for lighting bridge platform.
- c) Four (4) no.s - 250 W HPSV lamps shall be provided under the bridge as specified in the data sheet "A"
- d) All lighting fixtures shall be mounted with anti-vibration mounting and shall be easily accessible for maintenance.
- e) 24V - 5A - 3 pin industrial socket outlets shall be provided. Minimum four (4) on the bridge along the walk way on both sides of full length platforms.
- f) One (1) portable 40 W hand lamp with min. half span length flexible cable for inspection of crane components.

**3.4.13 Grounding**



TITLE

**Technical Specification for**  
Double girder EOT cranes for BFP, Sea  
Water intake pump house (Up to 50T Cap)  
**STANDARD TECHNICAL SPECIFICATION**

SPECIFICATION NO. PE-TS-412-501-A101

VOLUME: II B

REV 00

Section D

June 2015

Page 19 of 23

- 3.4.13.1 The crane structure, motor frame and all other electrical equipment/s shall be grounded in accordance with the Indian Electricity Rules. The connections from Crane Bridge to 4th conductor of down shop leads shall be by means of current collector.
- 3.4.13.2 The equipment fed by flexible cables shall be grounded by means of fourth core provided in the flexible trailing cable. Pendant push button station shall be earthed Separately.
- 3.4.13.3 The crane structures, motor frames & metal of all electrical equipment on EOT crane shall be effectively grounded as per Indian Electricity Rules. Grounding of the crane to the nearest pit shall be in manufacturer's scope.
- 3.4.14 Red warning light 3 Nos. shall be provided at both ends of the gantry girder to indicate the aliveness of DSL.
- 3.4.15 **Wiring Systems**
- All electrical equipment, accessories and wiring shall have tropical protection involving special treatment of insulation and metal against fungus, insects and corrosion. All cabling shall be carried out using XLPE insulated fire resistant (FRLS) cables & wiring by Heat resistance PVC wires with stranded conductor
  - All wiring shall be done with 1100V grade fire resistance PVC insulated wire in conduits or by 1100V grade PVCA PVC cables with extruded inner sheath.
  - For selecting the cable rating, cable for power wiring, consideration shall be given to the motor duty, ambient temperature grouping and disposition of the cables voltage drop etc.
  - Armoured cables or un-armoured running through the flexible conduits may be used for power wiring / control and auxiliary circuit wiring shall run through flexible conduits.
  - Each motor shall be wired independently. Power and control wiring shall be effectively separated.
  - Each wire shall be identified at both ends with wire designation in accordance with circuit wiring diagram.
  - All wire termination to the panels shall be provided with clamp type connections screw. Screw Type terminals with screw directly impinging on conductors are not acceptable.
  - Multi way terminal blocks complete with screw nut, washer and marking strips shall be furnished for terminating the panel wiring.



TITLE

**Technical Specification for**  
Double girder EOT cranes for BFP, Sea  
Water intake pump house (Up to 50T Cap)  
**STANDARD TECHNICAL SPECIFICATION**

SPECIFICATION NO. PE-TS-412-501-A101

VOLUME: II B

REV 00

Section D

June 2015

Page 20 of 23

- i) Not more than two wires shall be connected to any terminal on either side of terminal block. If necessary number of terminals shall be jumped together to provide the wiring points
- j) Each terminal block shall be marked with designation in accordance with conductors wiring diagram.

### **TECHNICAL SPECIFICATION FOR VVVF DRIVE**

#### **1.0 General**

- a) This part of the specification describes the general requirements for the Variable Voltage Variable frequency Drives, herein referred to as AC Drives, for use with standard IEC design AC squirrel cage induction motors. The nominal values, the standard documents and the drive's minimum performance are defined in this part. **To avoid any mismatch between the motor and its control equipment, the AC Drive shall be capable of auto adjustment by automatic measurement of the motor parameters with/without motor rotation.**
  - i. Speed control of EOT crane shall be through Variable Voltage Variable Frequency System (VVVF) with minimum 6 (six) pulse design.
  - ii. Necessary input & output devices to be provided to reduce harmonics, as per IEE519, at supply side of the drive at the switchgear.
  - iii. All necessary protections e.g. Input Phase Loss, Earth Fault, Over Voltage, Output Short Circuit, Load Loss, Input Transient Protection, Overload etc. to be provided.
  - iv. VVVF system shall be capable of generating suitable starting torque (upto 400% typical) with / without encoder, however starting current shall not exceed 150% of the rated torque.
  - v. VVVF system shall be capable of withstanding upto 50 deg C. ambient temp without derating
  - vi. Squirrel cage Induction motor with VPI insulation shall be provided with VVVF system.
  - vii. Protective Pane Provided with isolating switch, power contactor control and indication to switch ON/OFF power to starter panels, control and lighting transformer.



TITLE

**Technical Specification for**  
Double girder EOT cranes for BFP, Sea  
Water intake pump house (Up to 50T Cap)  
**STANDARD TECHNICAL SPECIFICATION**

SPECIFICATION NO. PE-TS-412-501-A101

VOLUME: II B

REV 00

Section D

June 2015

Page 21 of 23

viii. Starter Panel:

Separate VVVF system panels to be provided for CT, LT and hoist motion

(a) Contactors: AC 4 duty for reversing application AC 3 duty for non-reversing application

(b) Switches: AC 23 for motor application, AC 22 for other application.

(c) Fuses: HRC

(d) Overload relay: Temperature compensated, bimetallic with single phasing preventor.

ix. Panel shall be fabricated out of 1.6 mm thick rolled sheet steel. IP 52 degree of protection. Paint shade shall be RAL 9002 for front & rear and RAL 5012 for side covers. Space heaters to be provided.

## 2.0 User interface

### 2.1 General

The user interface shall be identical throughout the power range and type to avoid confusion amongst the users and need for training in several different units.

### 2.2 Inputs and outputs

A. At least, the following standard Inputs and Outputs shall be provided, to be used in interface with the control system:

Analogue Inputs : 1 x Programmable differential voltage input  $\pm 10V$ ,  
1 x Programmable current input 0(4) - 20mA  
1 x Programmable voltage input 0 – 10V

Analogue Output : 1 x Programmable analogue outputs 0(4) - 20mA or 0 – 10V

Logic inputs : 6 x Programmable logic Inputs isolated from the mains

Relay Outputs : 2 x Programmable Digital outputs with a changeover dry contact

All the control terminals shall be clearly marked.

B. At least, it shall be possible to assigned the following functions to the I/Os:

<b>Analogue input</b>	<b>Analogue outputs</b>
-----------------------	-------------------------



**TITLE**  
**Technical Specification for**  
Double girder EOT cranes for BFP,Sea  
Water intake pump house (Up to 50TCap)  
**STANDARD TECHNICAL SPECIFICATION**

**SPECIFICATION NO.** PE-TS-412-501-A101  
**VOLUME:** II B  
**REV** 00  
**Section D** **June 2015**  
Page 22 of 23

Speed reference Summing reference	Motor current Motor frequency Motor torque Motor power
<b>Logic input</b>	<b>Relay or logic outputs (open collector)</b>
Forward Reverse Jog Preset speeds Reference switching Ramp switching Parameter sets selection Fast stop Freewheel stop + speed - speed External fault	Ready Drive running High speed attained Drive fault Frequency threshold attained Motor thermal state attained Torque or current limitation attained Brake control

### 2.3 Programming terminal

- A. The AC drive shall have a keypad /display for programming and controlling purposes. An IP54 or IP65 remote mounting shall be possible at a distance of 10m.
- B. Password protection shall be provided to avoid unauthorized tampering with the set parameters.
- C. The programming terminal shall be able to display the commercial reference of the AC drive and of the options, the software version, the serial number
- D. Direct keypad entry shall be provided to observe the following actual parameters. Any one of the following parameters or actual values shall be selected to be always displayed:-
- i) Input Voltage
  - ii) Input Frequency
  - iii) Output Frequency
  - iv) Output Power
  - v) Output Current
  - vi) Motor Speed

The following parameters shall always be displayed during normal operation:-

- i) Drive Status



**TITLE**

**Technical Specification for**  
Double girder EOT cranes for BFP,Sea  
Water intake pump house (Up to 50TCap)  
**STANDARD TECHNICAL SPECIFICATION**

SPECIFICATION NO. PE-TS-412-501-A101

VOLUME: II B

REV 00

Section D

June 2015

Page 23 of 23

The following drive control functions at least shall be available from the keypad :-

- i) Run
- ii) Stop
- iii) Local / Remote selection.
- iv) Forward/Reverse (if function enabled)
- v) Accelerate
- vi) Decelerate
- vii) Parameter setting

#### 2.4 Application programming

The AC Drive shall be designed for both simple and the most complicated applications, yet it shall be user friendly. It shall be possible to reset the parameter settings back to the original factory settings through the keypad.

#### 2.5 PC Tools

The AC Drive Supplier shall have a Windows based PC software available for monitoring and controlling the AC Drives, and the software shall be offered as an option. The software shall be supplied with the necessary hardware and a provision for connecting a PC with the AC Drives. It shall be possible to set and modify parameters, control the drive, read actual values and make trend analysis using the software.

### 3.0 Software features

#### A. Restart

In the event of a fault trip due to over voltage, over current or loss of analogue signal, the AC DRIVE shall be programmable to attempt an automatic restart. For safety reasons, the maximum number of attempts shall be within a selectable time. If the fault does not clear after the attempts, the drive shall lock out.

#### B. Brake logic control

The AC Drive shall have a built-in function to control a mechanical brake in order to move the load in a smooth and safe way. The brake logic control shall be adapted to the different movements: hoisting, travel, orientation.

### 4.0 Preferred makes:

As per attached sub-vendor list.



**TECHNICAL SPECIFICATION FOR**  
**Double Girder EOT Cranes for BFP, Sea**  
**water Intake pump house ( up to 50 T Cap.)**  
**2X660 MW SEZ ENNORE STPP**

SPECIFICATION NO. PE-TS-412-501-A101

VOLUME III

REV 00

DATE June 2015

**DRAWINGS / DOCUMENTS TO BE SUBMITTED WITH THE BID**

Bidder shall submit the following drawings / documents along with their bid

- a) Singed & stamped copy of Electrical load list
- b) Deviation schedule with reference to specific clauses of the specification along with reason for such deviation in the format given under Vol.-III

or

“ No deviation certificate”

- c) Un priced copy of price format indicating quoted/ not quoted against each row/column
- d) Copy of pre-bid clarifications, if any, duly signed & stamped
- e) Signed/ Stamped copy of Compliance cum Confirmation Certificate (Vol.-III)

OFFER WILL BE CONSIDERED AS INCOMPLETE IN ABSENCE OF ANY OF ABOVE DOCUMENTS. DOCUMENT OTHER THAN ABOVE, IF ANY, SUBMITTED WITH THE OFFER WILL NOT FORM PART OF CONTRACT AND ACCORDINGLY WILL NOT BE CONSIDERED FOR BID EVALUATION.

**TITLE:**

2x660 MW SEZ ENNORE STPP  
Technical specification for Double girder EOT  
cranes for BFP, Sea water Intake pump house  
( Up to 50T Cap.)

Spec no.-I PE-TS-412-501-A101

VOLUME: III

SECTION:

REV. NO. 00

SHEET 1 OF 2

**COMPLIANCE CUM CONFIRMATION CERTIFICATE**

The bidder shall confirm compliance with following by signing / stamping this compliance certificate (every sheet) and furnish same with the offer.

- a) The scope of supply, technical details, construction features, design parameters etc. shall be as per technical specification & there are no exclusions, other than those mentioned under "exclusion and those resolved as per 'Schedule of Deviations', with regard to same.
- b) There are no other deviations w.r.t. specifications other than those furnished in the 'Schedule of Deviations'. Any other deviation, stated or implied, taken elsewhere in the offer stands withdrawn unless specifically brought out in the 'Schedule of Deviations'
- c) Bidder shall submit QP in the event of order based on the guidelines given in the specification & QP enclosed therein. QP will be subject to BHEL / CUSTOMER approval & customer hold points for inspection / testing shall be marked in the QP at the contract stage. Inspection / testing shall be witnessed as per same apart from review of various test certificates/ Inspection records etc. This is within the contracted price without any extra implications to BHEL after award of the contract.
- d) All drawings/ data-sheets / calculations etc. submitted along with the offer shall not be taken cognizance off.
- e) The offered materials shall be either equivalent or superior to those specified in the specification & shall meet the specified / intended duty requirements. In case the material specified in the specifications is not compatible for intended duty requirements then same shall be resolved by the bidder with BHEL during the pre-bid discussions, otherwise BHEL / Customer's decision shall be binding on the bidder whenever the deficiency is pointed out.

For components where materials are not specified, same shall be suitable for intended duty, all materials shall be subject to approval in the event of order.

- f) The commissioning spares shall be supplied on 'As Required Basis' & prices for same included in the base price itself.
- g) All sub vendors shall be subject to BHEL / CUSTOMER approval in the event of order.
- h) Guarantee for plant/equipment shall be as per relevant clause of GCC / SCC / Other Commercial Terms & Conditions
- i) In the event of order, all the material required for completing the job at site shall be supplied by the bidder within the ordered price even if the same are additional to approved billing break up, approved drawing or approved Bill of quantities within the scope of work as tender specification. This clause will apply in case during site commissioning, additional requirements emerges due to customer and / or consultant's comments. No extra claims shall be put on this account

**TITLE:**

2x660 MW SEZ ENNORE STPP  
Technical specification for Double girder EOT  
cranes for BFP, Sea water Intake pump house  
( Up to 50T Cap.)

Spec no.- PE-TS-412-501-A101

VOLUME: III

SECTION:

REV. NO. 00

SHEET 2 OF 2

- j) Schedule of drawings submissions, comment incorporations & approval shall be as stipulated in the specifications. The successful bidder shall depute his design personnel to BHEL's / Customer's / Consultant's office for across the table resolution of issues and to get documents approved in the stipulated time.
- k) As built drawings shall be submitted as and when required during the project execution.
- l) The bidder has not tempered with this compliance cum confirmation certificate and if at any stage any tempering in the signed copy of this document is noticed then same shall be treated as breach of contract and suitable actions shall be taken against the bidder.
- m) Successful bidder shall furnish detailed erection manual for each of the equipment supplied under this contract at least 3 months before the scheduled erection of the concerned equipment / component or along with supply of concerned equipment / component whichever is earlier.
- n) Document approval by customer under Approval category or information category shall not absolve the vendor of their contractual obligations of completing the work as per specification requirement. Any deviation from specified requirement shall be reported by the vendor in writing and require written approval. Unless any change in specified requirement has been brought out by the vendor during detail engineering in writing while submitting the document to customer for approval, approved document (with implicit deviation) will not be cited as a reason for not following the specification requirement.
- o) In case vendor submits revised drawing after approval of the corresponding drawing, any delay in approval of revised drawing shall be to vendor's account and shall not be used as a reason for extension in contract completion.



Technical specification for Double girder EOT cranes for BFP, Sea water Intake pump house  
D Technical specification for Double girder EOT cranes for BFP, Sea water Intake pump house ( Up to 50T Cap.)

SPECIFICATION NO.: PE-TS-412-501-A301

VOLUME III PART A

SHEET OF

Pre-bid Clarification schedule

Sl. no.	Section/Clause/Page No.	Statement of the referred clause	Clarification required

The bidder hereby certifies that above mentioned are the only clarifications required on the technical specification for the subject package.

SIGNATURE:

NAME:

DESIGNATION:

COMPANY:

DATE:

COMPANY SEAL



PROJECT:-2X660 MW SEZ ENNORE STPP

PACKAGE:- Double girder cranes for BFP , Sea water intake pump house ( up to 50T capacity)

TENDER ENQUIRY REFERENCE:-

NAME OF VENDOR:-

SL NO	VOULME/SECTION	PAGE NO.	CLAUSE NO.	TECHNICAL SPECIFICATIO N/ TENDER DOCUMENT	COMPLETE DESCRIPTION OF DEVIATION	COST OF WITHDRAWAL OF DEVIATION	REFERENCE OF PRICE SCHEDULE ON WHICH COST OF WITHDRAWL OF DEVIATION IS APPLICABLE	NATURE OF COST OF WITHDRAWAL OF DEVIATION (POSITIVE/ NEGATIVE)	REASON FOR QUOTING DEVIATION
-------	----------------	----------	------------	---	-----------------------------------	---------------------------------	---	--	------------------------------

**TECHNICAL DEVIATIONS**

**COMMERCIAL DEVIATIONS**



**PARTICULARS OF BIDDERS/ AUTHORISED REPRESENTATIVE**

NAME	DESIGNATIONS	SIGN & DATE

**NOTES:**

- For self manufactured items of bidder, cost of withdrawal of deviation will be applicable on the basic price (i.e. excluding taxes, duties & freight) only.
- For directly dispatchable items, cost of withdrawal of deviation will be applicable on the basic price including taxes, duties & freight.
- All the bidders have to list out all their Technical & Commercial Deviations (if any) in detail in the above format.
- Any deviation not mentioned above and shown separately or found hidden in offer, will not be taken cognizance of.
- Bidder shall submit duly filled unpriced copy of above format indicating "quoted" in "cost of withdrawal of deviation" column of the schedule above along with their Techno-commercial offer, wherever applicable.
- Bidder shall furnish price copy of above format along with price bid.
- The final decision of acceptance/ rejection of the deviations quoted by the bidder shall be at discretion of the Purchaser.
- Bidders to note that any deviation (technical/commercial) not listed in above and asked after Part-I opening shall not be considered.
- For deviations w.r.t. Payment terms, Liquidated damages, Firm prices and submission of E1/ E2 forms before claiming 10% payment, if a bidder chooses not to give any cost of withdrawal of deviation loading as per Annexure-VIII of GCC. Rev-06 will apply. For any other deviation mentioned in un-priced copy of this format submitted with Part-I bid but not mentioned in priced copy
- Any deviation mentioned in priced copy of this format, but not mentioned in the un-priced copy, shall not be accepted.
- All techno-commercial terms and conditions of NIT shall be deemed to have been accepted by the bidder, other than those listed in unpriced copy of this format.
- Cost of withdrawal is to be given seperately for each deviation. In no event bidder should club cost of withdrawal of more than one deviation else cost of withdrawal of such deviations which have been clubbed together shall be considered as NIL.
- In case nature of cost of withdrawal (positive/negative) is not specified it shall be assumed as positive.
- In case of discrepancy in the nature of impact (positive/ negative), positive will be considered for evaluation and negative for ordering.

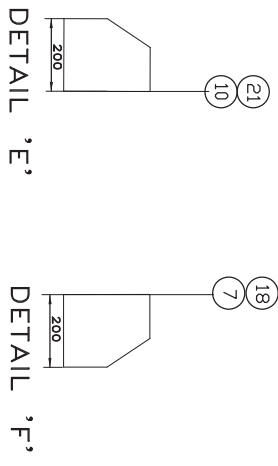
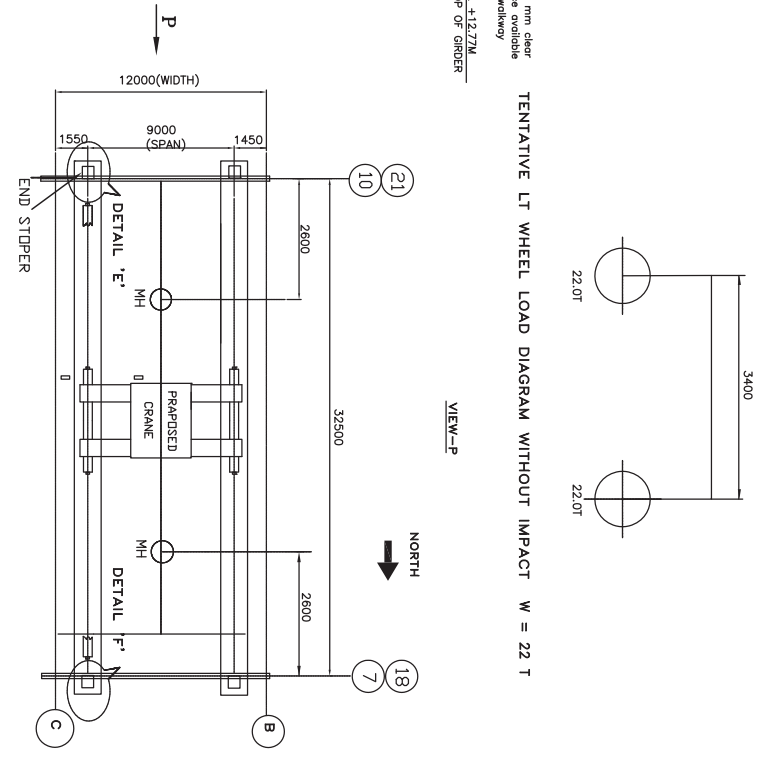
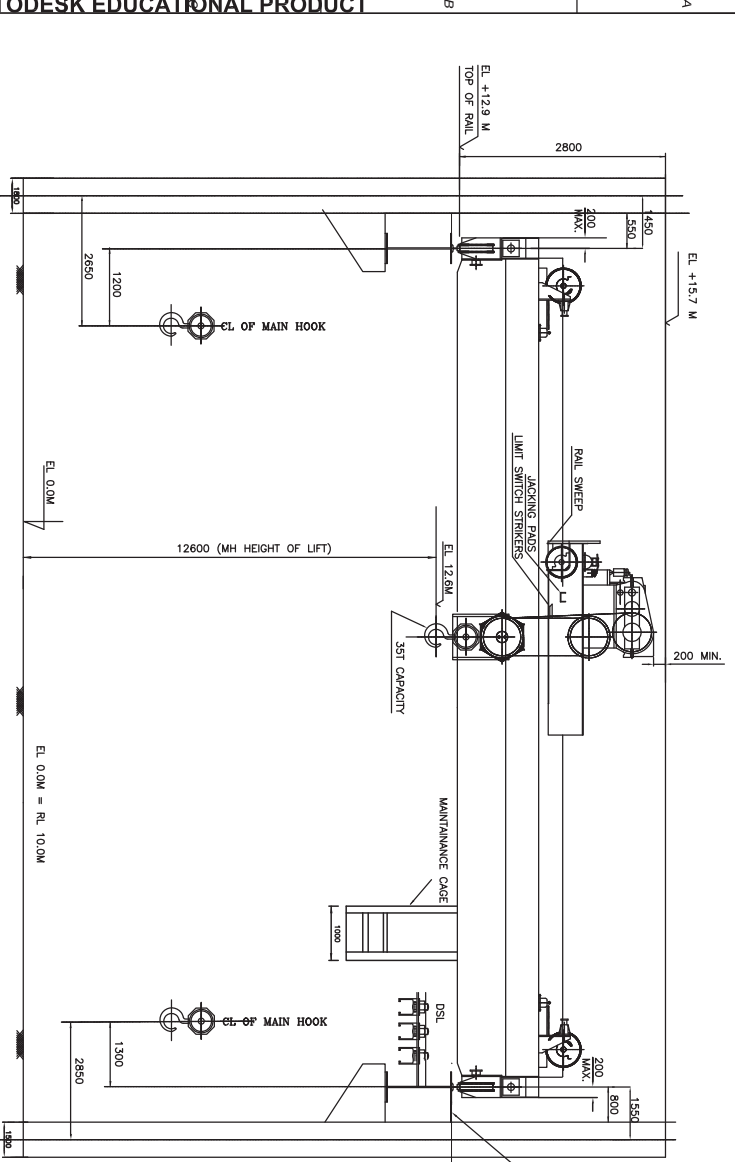



NOTES

1) ALL DIMENSIONS ARE IN MM & DECIMALS IN METERS.

2) HEAD ROOM (2850 mm) DISTANCE FROM TOP OF CANTILEY RAIL TO BOTTOM OF ROOF INCLUDING 200 mm FOR CLEARANCE.

3) TOTAL NO. OF CRANES = 2 nos.

REV	DATE	BY	CHK	APP	DATE	BY	CHK	APP

SUB-CONTRACTOR		DATE	
TITLE: CRANE CLEARANCE DIAGRAM OF BPP CRANE		PROJECT NO:	
387 (COUBLE GIRDER) E.O.T. CRANES (2 Nos)		PROJECT NAME:	
PROJECT LOCATION:		DRAWN BY:	
PROJECT ENGINEERING MANAGEMENT		CHECKED BY:	
NEW DELHI		DATE:	

