



TITLE:
**TECHNICAL SPECIFICATION FOR
 OZONE GENERATION PLANT**
**1X700 MW BELLARY THERMAL POWER
 STATION UNIT NO. 3, STAGE-3**

BHEL DOCUMENTS NO.: PE-TS-367-174-14000A-A001

VOLUME **II-B**

SECTION –D1

REV. NO. 02

DATE: 04/12/2014

7.2	Code	IS:2266
7.3	Factor of safety	Not less than 5
7.4	No. of full laps on the drum at extreme low position of hook	Rope shall be of sufficient length so that 3 (three) full laps remain on the drum at extreme low position of the hook not taking into consideration the turns covered by the wore rope anchorage and one spare groove for each lead of the wire rope on the drum when hook is at its highest position.
8.0	Load Hook and block	
8.1	Type of load hook	Plain shank type swiveling with safety latch (section: circular/ trapezoidal/'c' type)
8.2	Load hook Code	IS:15560
8.3	Load hook Material	As per IS: 1875, min. C 20 forged
8.4	Hook suspension	Thrust bearing
9.0	Gear (Hoisting)	
9.1	Type	Spur / Helical
9.2	Material	Gear: 16 Mn Cr 5 / 20 Mn Cr 5 / C40 / C50 / EN19 / EN24 / SAE 8620 / 16 Cr Ni 4 / 18 Ni Cr Mo5 / 39 Ni Cr. MO3 / 42 Cr MO4
9.3	Bearing type	Antifriction Ball
10.0	Trolley drive	
10.1	Wheel	Single flange taper thread
10.2	Wheel conform to (Std. / code)	IS: 3938
10.3	Wheel material	As per IS 3938
10.4	Bearing type	Antifriction Ball
11.0	SHEAVE	
11.1	Material	Cast / forged steel. IS: 2062 Gr. B / as per IS: 3938
11.2	Bearing type	Antifriction Ball
12.0	BRAKE (Hoist)	
12.1	Type	ACEM / DC EM brakes
12.2	Capacity	150 % of FLT
12.3	Number	One number for each motor
13.0	BRAKE (Trolley)	
13.1	Type	ACEM / DC EM brakes
13.2	Capacity	125 % of FLT or 100% of motor torque (Which ever is higher)



TITLE:
**TECHNICAL SPECIFICATION FOR
 OZONE GENERATION PLANT**
**1X700 MW BELLARY THERMAL POWER
 STATION UNIT NO. 3, STAGE-3**

BHEL DOCUMENTS NO.: PE-TS-367-174-14000A-A001

VOLUME **II-B**

SECTION –D1

REV. NO. 02

DATE: 04/12/2014

13.3	Number	One number for each motor
14.0	ROPE DRUM	
14.1	Material	As per IS 3938. Seamless steel pipe. ASTM A106 /A53 grade B
14.2	Type of groove	Right hand groove or Right hand and left hand groove
14.3	Spare groove on drum	One (1) spare groove when the hook is at its highest position
15.0	TYPE OF DSL	
15.1	Travel	PVC shrouded bus bar conductor type
16.0	MOTORS (for hoisting and trolley)	(As per IS: 325 & IS : 3938)
16.1	Type	Sq. Cage induction, TEFC, S4 duty, 40% CDF
16.2	Number of start	150 starts / hr
16.3	Voltage, Phase and Frequency	415V + 10%, 3 phase, 4 wire, 50 Hz, $\pm 5\%$, combined variation of $\pm 10\%$
16.4	Class of insulation	Class "F" and temperature rise limited to class "B".
16.5	Type of enclosure	TEFC
16.6	Degree of protection provided for enclosure	IP-55
16.7	Margin	Margin for motor rating shall be 15% over maximum power requirement at the rated speed.
16.8	RPM	Shall not exceed 1500RPM
16.9	Starting torque	The starting torque of the main motor shall be minimum 225% of FLT
16.10	Pull out torque	275% of FLT
17.0	LIMIT SWITCHES	Hoisting / lowering Trolley
17.1	Type	Snap action, self actuating type / two way lever
18.0	Operation from	Pendant push button for all motions of hoist
19.0	Power cable	FRLS / EPR flexible Cu cable / Aluminum cable
20.0	Control cable	FRLS / EPR flexible Cu cable / Aluminum cable
21.0	Control Voltage	110 V
22.0	Buffer stop/wheel stop	Buffer shall be provide at the end of monorail beam



TITLE:

**TECHNICAL SPECIFICATION FOR
OZONE GENERATION PLANT**

**1X700 MW BELLARY THERMAL POWER
STATION UNIT NO. 3, STAGE-3**

BHEL DOCUMENTS NO.: PE-TS-367-174-14000A-A001

VOLUME II-B

SECTION -D2

REV. NO. 02

DATE: 04/12/2014

SECTION – D2

D2: GENERAL TECHNICAL REQUIREMENTS FOR ELECTRICAL

BHEL – PS - PPEI: NOIDA, SECTOR-16A, U.P. – 201301



TITLE:

**TECHNICAL SPECIFICATION FOR
OZONE GENERATION PLANT**

**1X700 MW BELLARY THERMAL POWER
STATION UNIT NO. 3, STAGE-3**

BHEL DOCUMENTS NO.: PE-TS-367-174-14000A-A001

VOLUME II-B

SECTION -D2

REV. NO. 02

DATE: 04/12/2014

GENERAL TECHNICAL REQUIREMENTS FOR MOTORS

BHEL – PS - PPEI: NOIDA, SECTOR-16A, U.P. – 201301

KPCL/BTPS/03/EPC	KARNATAKA POWER CORPORATION LIMITED	SECTION: D2.23
	BELLARY TPS.UNIT-3 OF 700 MW	VOLUME-IV
	TITLE MOTORS	SHEET 1 OF 6
<p>1.0</p> <p>1.1</p> <p>1.2</p> <p>1.3</p> <p>1.4</p> <p>1.5</p> <p>1.6</p> <p>1.7</p> <p>1.8</p> <p>1.9</p> <p>1.10</p>	<p>A.C. MOTORS</p> <p>All HT motors shall be suitable for 11kV / 3.3kV, 3 phase, 50 Hz and LV motors shall be suitable for 415V, 3 Phase, 50 Hz power supply.</p> <p>The motor rating shall be arrived at considering 15% margin over the duty point input or 10% over the maximum demand of the driven equipment, whichever is higher. Motors shall be capable of starting and accelerating the load with the applicable method of starting without exceeding acceptable winding temperatures when supply voltage is 80% of the rated voltage for HT motors and 85% for LV motors. HT motors shall also be capable of satisfactory operation at full load at a supply voltage of 80% of the rated voltage for 5 min., commencing from hot condition.</p> <p>Motors shall be capable of developing the rated full load torque even if the supply voltage drops to 70% of the rated voltage. If such operation is envisaged for a period of one second, the pull out torque of the motor shall be atleast 205% of full load torque.</p> <p>Motors shall withstand for 1 second the voltage and torque stresses developed due to the vector difference between the motor residual voltage and the incoming supply voltage equal to 150% of the rated voltage during fast change over of buses.</p> <p>Locked rotor current of the HT motors rated 1500 kW and below shall be limited to 600% inclusive of 20% tolerance of the full load current of the motors and motor rated above 1500 kW shall be limited to 450% (inclusive of 20% tolerance) of full load current of the motor. Locked rotor current of the LV motor shall not exceed 600% of full load current inclusive of 20% tolerance.</p> <p>The locked rotor withstand time under hot condition at 110% rated voltage shall be more than the starting time at minimum permissible voltage specified above by atleast three seconds or 15% of the accelerating time whichever is greater. Provision of speed switch shall be avoided to the extent possible.</p> <p>The degree of protection for the motor enclosure shall be IP-55 and IP-54 for outdoor & indoor respectively and terminal boxes shall be provided with atleast IP-55. For single core cable termination, gland plates shall be of non-magnetic material. All motors located in hazardous area shall have flame proof design.</p> <p>All HT motors shall be provided with vibration pads for mounting vibration detectors.</p> <p>Motors rated 1000 kW and above shall be provided with differential protection. These motors shall be provided with star connected stator windings. The 3 nos. current transformers, one for each phase shall be mounted in a separate compartment in the neutral side terminal box. The three phases shall be connected to form the star point after they pass through the CTs. The CTs shall be of relay accuracy and the CT characteristics shall be compatible with the differential relay. The additional 3 nos. CTs of identical characteristics shall be provided in the 11kV / 3.3 kV switchgear panel. kWh meters shall be provided on all motor feeders.</p> <p>The ring oiling system shall be adequate for starting and continuous operation of the motor for atleast one half hour without pressure oiling system in operation.</p>	

KPCL/BTPS/03/EPC	KARNATAKA POWER CORPORATION LIMITED	SECTION: D2.23
	BELLARY TPS.UNIT-3 OF 700 MW	VOLUME-IV SHEET 2 OF 6
	TITLE	
	MOTORS	
1.11	For 11kV & 3.3kV motors, 6 nos. duplex/ 12 nos. simplex RTDs for winding shall be provided. Each bearing shall be provided with one no.PT-100 duplex type RTDs for temperature monitoring. These motors shall be designed to withstand atleast 5% harmonics in the supply voltage.	
1.12	The maximum double amplitude vibrations for motors upto 1500 rpm shall be 25 microns and 15 microns upto 3000 rpm. For 415V motors, maximum double amplitude vibrations upto 1500 rpm shall be 40 microns and 15 microns upto 3000 rpm.	
1.13	Maximum noise level measured at a distance of 1 metre from the outer surface of the motor shall not exceed 85 dB (A).	
1.14	Cable boxes of all 11kV & 3.3kV motors shall be provided with quick disconnecting type terminal connectors to facilitate easy disconnection and removal of the motors without requiring unsealing or otherwise disturbing the external cable connections and leaving the phase segregated terminal box intact.	
1.15	The insulation system for 11000V & 3300 V AC motors shall withstand the negative or positive 0.3 / 3.0 microsecond wave (2.7 pu rated peak line to earth operating voltage) switching surges originating from non-effectively earthed power system. All 11000V & 3300 V AC motors shall have BIL and withstand frequency voltage as per relevant standards.	
1.16	If required by the system, variable frequency controller shall be provided for I.D.Fans.	
2.0	DC MOTORS	
2.1	DC motors shall be suitable for the DC system voltage available in the plant. Motor shall be capable of starting and accelerating the load with the applicable method of starting, without exceeding acceptable winding temperatures, when the supply voltage is in the range of 85% to 110% of rated motor voltage. The field windings for the motors shall be continuously rated without forced ventilation.	
3.0	ACTUATOR MOTORS	
3.1	The actuator motors shall be designed for short time duty (S2) in accordance with IEC 60034-1.	
3.2	Hand wheel operation shall be provided in addition to motor drive.	
3.3	The DC and AC actuator shall be provided with accessories viz., Torque limit switch, end of travel switch, adjustable limit switch, hand wheel motor, thermostat, integral starter, valve position indicator, Manual-Auto lever with suitable locking arrangement, etc.. Complete actuator shall be tested at factory as per IS 9334.	
3.4	Two normally open and two normally closed or two changeover potential free contacts corresponding to open and close positions of the valve shall be provided.	
3.5	Degree of protection for actuator motor enclosure shall be IP-55 and IP-67 for indoor and outdoor respectively.	

KPCL/BTPS/03/EPC 	KARNATAKA POWER CORPORATION LIMITED BELLARY TPS, UNIT-3 OF 700 MW	SECTION: D2.23 VOLUME-IV SHEET 3 OF 6
	TITLE MOTORS	

4.0 TESTS

- 4.1 Tests on all types of motors shall be conducted as per relevant standard.
- 4.2 All type, routine & acceptance tests as per relevant IS shall be conducted on 11 kV & 3.3 kV motors. For LT motors, type test for each rating and frame size & make, and for all motors routine and acceptance tests shall be conducted as per relevant standards.
- 4.3 For 11000V and 3300V AC motors, in addition to all the tests specified above, polarisation index test shall be carried out as a routine test on each motor (the minimum value of polarisation index for all motors shall be 2 when determined according to IS : 7816).
- 4.4 Noise level measurement and vibration test as per standards shall be conducted on all motors.
- 4.5 Di-electric tests to establish the insulation withstand level of motors as indicated in Clause 1.15 shall be performed on a sample coil (identical to those to be used in the motor quoted for) for each type of motor. These tested sample coils shall not be used in the motors to be supplied.
- 4.6 All characteristic curves for the motors including hot and cold withstand characteristics, starting time vs current, current vs speed, speed vs torque at 110%, 100% and 90% of rated voltage, negative withstand characteristics, rotor voltage vs rotor current curves (for wound motors), Efficiency, power factor, slip, current Vs output curve etc., shall be furnished.

5.0 TECHNICAL REQUIREMENTS

The motors shall comply with the particulars indicated below and CONTRACTOR shall furnish the details in respective column given below (to be separately submitted for different type & rating of the motor).

SL NO.	DESCRIPTION	UNIT	SPECIFICATION REQUIREMENT	CONTRACTOR
I	AC Motors			
1.0	Application/Designation		*	
2.0	Manufacturer		*	
3.0	Type of motors/ frame size		Squirrel cage except for cranes	
4.0	Rated			
	(a) Output	kW	*	
	(b) Speed	rpm	*	
	(c) Voltage	V	*	

KPC/L/BTPS/03/EPC	KARNATAKA POWER CORPORATION LIMITED		SECTION: D2.23
	BELLARY TPS, UNIT-3 OF 700 MW		VOLUME-IV
	TITLE MOTORS		SHEET 4 OF 6
	(d) No. of Phases / Frequency		
	(e) System neutral		
5.0			
5.1	Type of Duty (IS-325 or equivalent)		
5.2	Duty designation (IS-325 or equivalent)		
6.0	Supply Conditions		
	(a) Allowable variations in		
	(i) Voltage	%	± 10
	(ii) Frequency	%	± 5
	(iii) Combined	%	± 10
	(b) Permissible unbalance in supply voltage	%	2
7.0	Current		
	(a) Full load	Amps,	
	(b) Starting	% FL	
8.0	Method of starting		DOL
8.1	Starting time	Sec	
	With rated Voltage		
	With min. Voltage		
	With Max. Voltage		
8.2	Safe stall time under hot/cold condition	Sec	
	With rated Voltage		
	With min. Voltage		
	With Max. Voltage		
9.0	Insulation		
9.1	Class of insulation		Class F with temperature rise limited to Class B

KPCL/BTPS/03/EPC		KARNATAKA POWER CORPORATION LIMITED		SECTION: D2.23	
		BELLARY TPS.UNIT-3 OF 700 MW		VOLUME-IV	
		TITLE MOTORS		SHEET 5 OF 6	
9.2	Temperature rise by winding resistance method	Deg. C	For LV motors (Temp. limited to 65°C), For HT motors (temp. rise limited to Class B)		
10.0	Type of cooling (IS : 6362)	Deg. C	TEFC for LV, TEFC / TETV/CACA for 11/3.3 KV motors.		
11.0	Degree of protection (IS:4691 or equivalent)		Refer Clause 1.7		
12.0	Suitable for outdoor operation	Yes / No	*		
13.0	Normal connection winding	Star / Delta	*		
14.0	Permissible No. of equally spread starts per hour under normal service conditions		*		
15.0	Efficiency (%)	%			
	Full load				
	75 % Load				
	50 % Load				
	25 % Load				
16.0	Power Factor				
	Full Load				
	75 % Load				
	50 % Load				
	25 % Load				
17.0	Torque				
	Starting				
	Maximum (Pullout)				
	Pull up				
18.0	Motor reactance (pu)				
	Subtransient				
	Transient				
	Steady state				
15.0	Fault level	kA/se c	*		

KPCL/BTPS/03/EPC 	KARNATAKA POWER CORPORATION LIMITED BELLARY TPS, UNIT-3 OF 700 MW		SECTION: D2.23
	TITLE MOTORS		VOLUME-IV SHEET 6 OF 6

Sl	DC MOTORS		
16.0	Rated Voltage	V	220 V DC
17.0	Class of Insulation	:	Class F with temperature rise limited to class B
18.0	Temperature rise	:	--- do ---
19.0	Method of starting	:	*
Items under AC motors which are applicable for DC motors shall also be listed			

NOTE :

- 1.0 Information shall be filled furnished by CONTRACTOR along with offer.



TITLE:
**TECHNICAL SPECIFICATION FOR
 OZONE GENERATION PLANT**
**1X700 MW BELLARY THERMAL POWER
 STATION UNIT NO. 3, STAGE-3**

BHEL DOCUMENTS NO.: PE-TS-367-174-14000A-A001
VOLUME II-B
 SECTION -D2
 REV. NO. 02 DATE: 04/12/2014

DATA SHEET – C OF MOTORS

S. No.	Description	Data to be filled by successful bidder
A.	vi) General	
1	Manufacturer & country of origin	
2	Motor type	
3	Type of starting	
4	Name of the equipment driven by motor & Quantity	
5	Maximum Power requirement of driven equipment	
6	Rated speed of Driven Equipment	
7	Design ambient temperature	
B.	vii) Design and Performance Data	
1	Frame size & type designation	
2	Type of duty	
3	Rated Voltage	
4	Permissible variation for	
5	a) Voltage	
6	b) Frequency	
7	c) Combined voltage & frequency	
8	Rated output at design ambient temp (by resistance method)	
9	Synchronous speed & Rated slip	
10	Minimum permissible starting voltage	
11	Starting time in sec with mechanism coupled	
12	a) At rated voltage	
13	b) At min starting voltage	
14	Locked rotor current as percentage of FLC (including IS tolerance)	
15	Torque	
	a) Starting	
	b) Maximum	
16	Permissible temp rise at rated output over ambient temp & method	
17	Noise level at 1.0 m (dB)	
18	Amplitude of vibration	



TITLE:
**TECHNICAL SPECIFICATION FOR
 OZONE GENERATION PLANT**
**1X700 MW BELLARY THERMAL POWER
 STATION UNIT NO. 3, STAGE-3**

BHEL DOCUMENTS NO.: PE-TS-367-174-14000A-A001
VOLUME II-B
 SECTION -D2
 REV. NO. 02 DATE: 04/12/2014

S. No.	Description	Data to be filled by successful bidder
19	Efficiency & P.F. at rated voltage & frequency	
	a) At 100% load	
	c) At 75% load	
	c) At starting	
C.	viii) Constructional Features	
1	Method of connection of motor driven equipment	
2	Applicable Standard	
3	DOP of Enclosure	
4	Method of cooling	
5	Class of insulation	
6	Main terminal box	
	a) Type	
	b) Power Cable details (Conductor, size, armour/unarmour)	
	c) Cable Gland & lugs details (Size, type & material)	
	d) Permissible Fault level (kArms & duration in sec)	
7	Space heater details (Voltage & watts)	
8	Flame proof motor details (if applicable)	
	a) Enclosure	
	b) suitability for hazardous area	
	i) Zone	O / I / II
	ii) Group	IIA / IIB / IIC
9	No. of Stator winding	
10	Winding connection	
11	Kind of rotor winding	
12	Kind of bearings	
13	Direction of rotation when viewed from NDE	
14	Paint Shade & type	
15	Net weight of motor	
16	Outline mounting drawing No (To be enclosed as annexure)	
D.	ix) Characteristic curves/ drawings (To be enclosed for motors of rating \geq 55KW)	
	a) Torque speed characteristic	



TITLE:

**TECHNICAL SPECIFICATION FOR
OZONE GENERATION PLANT**

**1X700 MW BELLARY THERMAL POWER
STATION UNIT NO. 3, STAGE-3**

BHEL DOCUMENTS NO.: PE-TS-367-174-14000A-A001

VOLUME II-B

SECTION -D2

REV. NO. 02

DATE: 04/12/2014

S. No.	Description	Data to be filled by successful bidder
	b) Thermal withstand characteristic	
	c) Current vs time	
	d) Speed vs time	



TITLE:

**TECHNICAL SPECIFICATION FOR
OZONE GENERATION PLANT**

**1X700 MW BELLARY THERMAL POWER
STATION UNIT NO. 3, STAGE-3**

BHEL DOCUMENTS NO.: PE-TS-367-174-14000A-A001

VOLUME II-B

SECTION -D2

REV. NO. 02

DATE: 04/12/2014

GENERAL TECHNICAL REQUIREMENTS FOR CABLES

BHEL – PS - PPEI: NOIDA, SECTOR-16A, U.P. – 201301

KPCL/BTPS/03/EPC 	KARNATAKA POWER CORPORATION LIMITED BELLARY TPS, UNIT-3 OF 700 MW TITLE CABLING SYSTEM	SECTION: D2.14 VOLUME-IV SHEET I OF 6
1.0 1.1 1.2 1.3 1.4 1.5	<p>CABLES</p> <p>H T Cables</p> <p>MV system (11kV & 3.3kV system) cables shall be unearthed grade suitable for use in medium resistance earthed system, with stranded & compacted aluminium conductors, extruded semi-conducting compound screen, extruded XLPE insulated, Dry cured extruded semi-conducting compound with a layer of non-magnetic metallic tape for insulation screen, extruded PVC (Type ST - 2) FRLS inner sheath, Aluminium / galvanised steel round wire armoured, extruded PVC (Type ST - 2) FRLS outer sheathed, single / multicore conforming to IS 7098 (Part II) for constructional details and tests.</p> <p>L T Power Cables</p> <p>LV Power Cable shall be 1100 V grade, <i>steam/singles/gas cured</i> single / multicore, stranded aluminium conductor, XLPE insulated, extruded with PVC inner sheath, Type ST - 2 and outer sheath made of FRLS PVC, Type ST-2 compound. The armoring shall be of Aluminium / galvanised steel round wire. The cable used for DC system shall be of single core type. All other details shall be as applicable. Minimum conductor cross section of power cables shall be 4 sq.mm.</p> <p>Control Cables</p> <p>Control cables shall be 1100V grade, multicore, minimum 2.5 sq.mm cross section, stranded copper conductor having 7 strands, PVC insulated, inner PVC sheathed, galvanised steel wire armoured and outer sheath made of FRLS PVC compound. In situations where accuracy of measurement or voltage drop in control circuit, warrant, higher cross sections as required shall be used. 4 sq.mm copper conductor cables shall be used for CT circuits all other specifications remaining same.</p> <p>Instrumentation Cables <i>Page 38, Mem part 2 of 3, 1.1KV</i></p> <p>Instrumentation cables shall be with stranded high conductivity annealed, tinned copper, twisted pair (with min. 20 twists per meter) extruded PVC insulated with overall and / or individual screening, extruded PVC inner sheathed, extruded outer sheathed with FRLS PVC compound and aluminium/galvanised steel wire armoured complying to IEC60189 - Part I & II</p> <p>The conductor size shall be minimum 0.5 sq.mm. Triplex cables similar to instrumentation cables can be used for RTDs.</p> <p>Lighting Wires</p> <p>1100V grade, single core, stranded, copper conductor, PVC insulated wires conforming to IS-694-1990 / IEC-60227 Part 1 to 5 (1979) / IEEE-719 (1981). Minimum cross section of copper wires shall be 2.5 sq. mm for lighting circuits and 4 sq. mm for receptacle circuits.</p>	

KPC/BT/PS/03/EPC	KARNATAKA POWER CORPORATION LIMITED BELLARY TPS, UNIT-3 OF 700 MW	SECTION: D2.14
	TITLE CABLING SYSTEM	VOLUME-IV SHEET 2 OF 6
<p>1.6 Trailing Power and Control cables for Mobile Equipment.</p> <p>11kV / 3.3 kV (UE) and 1100V (E) grade power & control flexible trailing, annealed tinned copper conductor, EPR insulated, EPR inner sheathed, CSP outer sheathed and shall have conductor screen of rubber. Cables shall conform to IS requirements and any other applicable standards.</p> <p>2.0 CABLE PROPERTIES</p> <p>2.1 All power, control and Instrumentation cable will be with armour. MV cables will be with FRLS PVC inner and outer sheath and other type of cables are with FRLS PVC, Outer sheath.</p> <p>All single core power cables will have wire armouring of aluminium, whereas multicore cables will have galvanised steel wire armouring.</p> <p>2.2 The outer sheath of all cables shall be of extruded layer of suitable synthetic material compatible with specified ambient and operating temperature of the cables. The sheath shall be resistant to water, UV radiation, fungus, termite and rodent attack.</p> <p>2.3 The inner and outer sheath of FRLS PVC compound shall meet the following performance requirements :</p> <p>(a) The critical oxygen index value shall be minimum 29 when tested at $27 \pm 2^\circ\text{C}$ as per ASTM-D-2863-77 and the temperature index will be minimum 250°C at oxygen index value of 21 when tested as per IES-715 ASTM-D-2863</p> <p>(b) The maximum acid gas generation as determined by titration shall be less than 20% by weight when tested as per IEC-60754-1 (1994).</p> <p>(c) The smoke generation under fire shall have maximum smoke density rating of 60% when tested as per ASTM-D-2843-7 (1988).</p> <p>(d) The cables will pass the hydraulic stability and ultraviolet tests as per DIN 53387.</p> <p>2.4 The finished cable shall pass the flammability test as per IEC-60322-1 (1993) and IEEE-60383. In addition, it shall also pass flammability test as per Class F3 of Swedish Standard SS-424-1475 (1978).</p> <p>3.0 DESIGN CRITERIA FOR CABLE SIZING</p> <p>3.1 Power cables</p> <p>Power cable sizes shall be selected on the basis of current carrying capacity, short circuit rating, permissible voltage drop and standardization of cable sizes.</p> <p>3.1.1 Power cables shall carry the full load current of the circuit continuously under site conditions considering the various derating factors like Thermal resistivity of soil, ambient air/ground temperature, grouping, method of laying, etc. The</p>		

<p>KPCL/BTPS/03/EPC</p> 	<p>KARNATAKA POWER CORPORATION LIMITED</p> <p>BELLARY TPS, UNIT-3 OF 700 MW</p>	<p>SECTION: 02.14</p> <p>VOLUME-IV</p>
	<p>TITLE</p> <p>CABLING SYSTEM</p>	<p>SHEET 3 OF 6</p>
<p>design ambient air and ground temperatures shall be considered at 50° C & 30° C respectively.</p> <p>3.1.2 Power cables shall withstand the fault current of the circuit for the duration not less than the maximum time taken by the primary protective system to isolate the fault. Fault clearing times for 11000V / 3300V motor feeders and transformer feeders having high-set instantaneous protection shall be 0.16 secs., whereas tie between two 415V switchgear and any two 11000V / 3300V switchgear shall be 0.5 secs., and for incomers and tie feeders 1.0 sec.</p> <p>The short circuit withstand capacity of screen in case of HT cables shall be 300 amps for 2(two) seconds per core.</p> <p>3.1.3 For 11000V / 3300V motors controlled by vacuum contactors with back-up HRC fuses, the minimum cross-section of cables shall be based on the cut-off current of the fuses and their fusing time.</p> <p>3.1.4 For the cables to 415V motors and feeders protected by fuses, the cross section shall be chosen according to the cut-off current of the fuse and its fusing time.</p> <p>3.1.5 Voltage dip at motor terminals during starting of motors will be limited to the following values :</p> <ul style="list-style-type: none"> (i) For coal mill motors – 10% of the rated voltage. (ii) For all motors except BFP – 15% of the rated voltage. (iii) For BFP motors – 20% of the rated voltage. (iv) For LV motors – 15% of the rated voltage. <p>3.1.6 Voltage drop in feeder cables between the transformer & PCC and between PCC & MCC, for full load current, shall be limited to 2 %. Further, the Voltage drop in feeder cables between PCC/MCC to Motor terminals shall be limited to 3% during full load running condition.</p> <p>3.1.7 For power supply to valve actuator motors, actuators of various isolating and regulating dampers and exhaust fans, 3 core 2.5 sq. mm stranded copper conductor cable may be used in view of ease of termination. These cables shall be in other respects similar to cables described in Clause 1.2 above.</p> <p>3.2 Control Cables</p> <p>3.2.1 Current transformers leads shall be checked for the lead burden vis-a-vis the current transformer VA capacity and 4 sq.mm cables shall be used for connection of CT to loads. In case 4 sq.mm conductor imposes unacceptable high burden on CTs, higher cross section of conductor shall be used.</p> <p>3.2.2 Voltage transformer leads shall be checked for voltage drop, which shall be limited to within 1% for all cases other than tariff metering. For tariff metering the voltage drop shall be limited to 0.2%. In case the voltage drop with 4 sq. mm Cu conductors exceed this value, higher conductor sizes shall be used.</p>		

KPCL/BTPS/03/EPC 	KARNATAKA POWER CORPORATION LIMITED BELLARY TPS.UNIT-3 OF 700 MW	SECTION: D2.14 VOLUME-IV SHEET 5 OF 6
	TITLE CABLING SYSTEM	
8.0 8.1 8.2 9.0 9.1 9.2 10.0	CABLE INSTALLATION AND ACCESSORIES All material and accessories required for cable installation like cable trays, tray covers, support steel, etc., shall be hot dip galvanised and conduits/pipes shall also be hot dip galvanised. The racks/trays, conduits/pipes, trenches required to route the cables to individual equipments shall be supplied and installed by the CONTRACTOR. Separate trays shall be provided for HV Power/LV Power (AC&DC)/Control & Instrumentation cables. CABLE TRAYS AND COVERS Cable trays shall be of ladder / perforated type complete with all necessary coupler plates, elbows, tees, bands, reducers, stiffeners and other accessories. Cable trays of ladder and perforated types and the associated accessories such as coupler plates, tees, elbows, etc. shall be fabricated from 12 gauge (2.5 mm thick) mild steel sheets, cable tray covers shall be fabricated from 16 gauge (1.7 mm thick) MS sheets. All the sheet steel shall be hot dip galvanised as per relevant standards. Cable trays shall be ladder type for power & control cables and perforated type for Instrumentation cables. Cables of sizes 120 sq.mm and above shall be laid in single layer. Single core cables used for 3 phase AC power circuits shall be laid in Trefoil form. FIRE-PROOF SEALING OF CABLE PENETRATION Cables / cable tray openings in walls and floors or through pipe sleeves from one area to another or one elevation to another, between the units and within the same unit, shall be sealed by a fire-proof sealing system. The fireproof sealing system (FPSS) shall effectively prevent the spread of fire from the flaming to the non-flaming side, in the event of a fire. The FPSS shall conform to relevant standard in addition to the following requirements : (a) FPSS shall have a fire rating of two hours. ✓ (b) The FPSS shall be subjected to fire endurance test, hose stream test, temperature measurement of non-flaming side as per ASTM-E119. 'Standard method of fire tests of building construction and materials'. (c) The FPSS will also conform to the incombustibility test carried out in accordance with IS:3144-1992. (d) Under fire condition, the FPSS material shall not emit excessive smoke or any corrosive or toxic fumes.	

KPCU/BTPS/03/EPC	KARNATAKA POWER CORPORATION LIMITED	SECTION: D2.14
	BELLARY TPS.UNIT-3 OF 700 MW	VOLUME-IV
	TITLE	SHEET 6 OF 6
CABLING SYSTEM		
11.0	FIRE BREAK	
11.1	Firebreak shall be provided by applying a suitable fire-resistant coating on cables for the required length to meet the fire rating of thirty minutes.	
11.2	Firebreak shall be provided at an interval of 15 metres in the straight portion of each of the cable tray above ground, at intervals of 30 metres in cable trenches and at 5M for all vertical trays. All cable inter section and tee offs shall be provided with firebreaks.	
12.0	TESTS	
	All tests shall be carried out as per relevant standards and approved GTP/QAP.	



TITLE:

**TECHNICAL SPECIFICATION FOR
OZONE GENERATION PLANT**

**1X700 MW BELLARY THERMAL POWER
STATION UNIT NO. 3, STAGE-3**

BHEL DOCUMENTS NO.: PE-TS-367-174-14000A-A001

VOLUME II-B

SECTION -D2

REV. NO. 02

DATE: 04/12/2014

**GENERAL TECHNICAL REQUIREMENTS FOR PANELS, CABINETS
& MISCELLANEOUS ELECTRICAL EQUIPMENTS**

BHEL – PS - PPEI: NOIDA, SECTOR-16A, U.P. – 201301

KPCL/BTPS/03/EPC 	KARNATAKA POWER CORPORATION LIMITED BELLARY TPS.UNIT-3 OF 700 MW	SECTION: D2.24 VOLUME-IV SHEET 1 OF 3
	TITLE CONTROL PANELS & CABINETS AND MISCELLANEOUS ELECTRICAL EQUIPMENT	

1.0 CONTROL PANELS & CABINETS AND MISCELLANEOUS ELECTRICAL EQUIPMENT

- 1.1 Indoor control panels provided for control of miscellaneous systems in the plant viz., air conditioning, evaporative air cooling, fire protection system and outdoor control cabinets shall comply with the requirements outlined under clause 1.5 below.
- 1.2 All the meters provided on the panel shall be min. 96 sq.mm with an accuracy class of 0.5 unless otherwise specified. Tariff meters shall have an accuracy of 0.2. All meters shall be of digital type.
- 1.3 The facia annunciation windows if provided on the panel, shall conform to requirements outlined under instrumentation and control section.
- 1.4 The required 240V, 1 phase AC supply required for panel illumination, receptacle and for space heating of panel shall be derived in the control panel itself.
- 1.5 **Technical Requirements**

SL. NO.	DESCRIPTION	REQUIREMENTS
1	Location	Indoor/Outdoor depending location
2	Type of mounting	Wall/Floor
3	Cable entry	Top/bottom depending on layout
4	Paint Finish: Outside/Inside	To be decided later/ glossy white.
5	Supply voltage	415V 3 phase 3 wire
6	Control transformer	Required to derive 110V control supply
7	Space heater, lighting supply voltage	240V, 1 phase AC
8	Applicable standards	
9	Switchgear general requirements	IS 4237
10	Factory built assemblies of switchgear and control gear for voltages upto and including 1000V AC & 1200V DC	IS 8623

KPCJ/BTPS/03/EPC 	KARNATAKA POWER CORPORATION LIMITED BELLARY TPS, UNIT-3 OF 700 MW	SECTION: D2.24 VOLUME-IV SHEET 2 OF 3
	TITLE CONTROL PANELS & CABINETS AND MISCELLANEOUS ELECTRICAL EQUIPMENT	

11	Air break switches	IS 13947 pt 1 & 2
12	Miniature circuit breakers	IS 8828
11.5	HRC cartridge fuses	IS 9224
11.6	Contactors	IS 2959
11.7	Control switches/push buttons	IS 6875
11.8	Current transformers	IS 2705
11.9	Voltage transformers	IS 3156
11.10	Relays	IS 3231
11.11	Indicating instruments	IS 1248
11.12	Arrangement for bus bars, main connections and accessories	IS 375
11.13	Degree of Protection	IS 2127 / 3427
11.14	Climate proofing of electrical equipment	IS 3202
11.15	Code of practice for phosphating iron & steel	IS 6005
11.16	Wrought aluminium and aluminium alloys for electrical purposes	IS 5082

- 2.0 Following miscellaneous equipment shall be included in CONTRACTOR's scope.
- 2.1 Local push button stations.
- 2.2 Junction boxes (JBs)
- 2.3 Danger boards
- 2.4 Rubber mats
- 3.0 **LOCAL PUSH BUTTON STATIONS (LPB)**
- 3.1 Local push button station shall be provided for all the drive motors of the plant (415V motors and 11kV & 3.3kV motors) (start stop push buttons for all motors; only stop push button for emergency motors).
- 3.2 The degree of protection of LPBs shall be IP55 with canopy for outdoor and IP54 for indoor applications.
- 3.3 All PBs shall be push to actuate type and the stop PB shall be lockable in off position.

KPC/BTPS/03/EPC 	KARNATAKA POWER CORPORATION LIMITED BELLARY TPS, UNIT-3 OF 700 MW	SECTION: D2.24 VOLUME-IV SHEET 3 OF 3
TITLE CONTROL PANELS & CABINETS AND MISCELLANEOUS ELECTRICAL EQUIPMENT		
<p>3.4 All push buttons shall be provided with 2 nos. NO and 2 nos. NC contacts for various interlocking purposes. One contact of stop PB shall be directly wired to the switchgear module for direct tripping and another contact to control system.</p> <p>4.0 JUNCTION BOXES (JBs)</p> <p>4.1 Junction boxes as required for the power plant shall be supplied :</p> <p>4.2 The JB's used in outdoor areas shall be weatherproof type. Sheet steel thickness of the JB's shall be minimum 2 mm. The sheet steel shall be hot dip galvanised.</p> <p>4.3 Junction boxes/marshalling boxes (JBs/MBs) shall be provided to enable running large core cables from (JB/MB) to control panels, terminal cabinets, etc.</p> <p>4.4 Clause deleted.</p> <p>5.0 Danger boards shall be provided in line with the statutory requirements.</p> <p>6.0 Rubber mats shall be provided to meet the safety and other statutory requirements.</p> <p style="text-align: center;">232</p>		



TITLE:

**TECHNICAL SPECIFICATION FOR
OZONE GENERATION PLANT**

**1X700 MW BELLARY THERMAL POWER
STATION UNIT NO. 3, STAGE-3**

BHEL DOCUMENTS NO.: PE-TS-367-174-14000A-A001

VOLUME II-B

SECTION -D3

REV. NO. 02

DATE: 04/12/2014

SECTION – D3

GENERAL TECHNICAL REQUIREMENTS FOR C&I

BHEL – PS - PPEI: NOIDA, SECTOR-16A, U.P. – 201301



TITLE:

**TECHNICAL SPECIFICATION FOR
OZONE GENERATION PLANT**

**1X700 MW BELLARY THERMAL POWER
STATION UNIT NO. 3, STAGE-3**

BHEL DOCUMENTS NO.: PE-TS-367-174-14000A-A001

VOLUME II-B

SECTION -D3

REV. NO. 02

DATE: 04/12/2014

GENERAL REQUIREMENT

- 1) Bidder shall provide complete and independent control & instrumentation system with all accessories, auxiliaries and associated equipments for the safe, efficient and reliable operation of Ozone generation plant.
- 2) The quantity of instruments for auxiliary system shall be as per tender P & ID wherever provided of the respective system as a minimum, for bidding purpose. However, Bidder shall also include in his proposal all the instruments and devices that are needed for the completeness of the plant auxiliary system/ equipment supplied by the bidder, even if the same is not specifically appearing in the P & ID. During detail engineering if any additional instruments are required for safe & reliable operation of plant, bidder shall supply the same without any price implication.
- 3) Measuring instruments/equipment and subsystems offered by the bidder shall be from reputed experienced manufacturers of specified type and range of equipment, whose guaranteed and trouble free operation has been proven. Further all the instruments shall be of proven reliability, accuracy, and acceptable international standards and shall be subject to employer's approval. All instrumentation equipment and accessories under this specification shall be furnished as per technical specification, ranges, makes/ numbers as approved by the employer' during detail engineering.
- 4) The necessary root valves, impulse piping, drain cocks, gauge-zeroing cocks, valve manifold and all the other accessories required for mounting/ erection of these local instruments shall be furnished, even if not specifically asked for, on as required basis. The contacts of equipment mounted instruments; sensors, switches etc for external connection including spare contacts shall be wired out to suitably located junction boxes.
- 5) The customer specification attached as Specific Technical Requirement will supersede the Data sheets, if there is any mismatch.



TITLE:

**TECHNICAL SPECIFICATION FOR
OZONE GENERATION PLANT**

**1X700 MW BELLARY THERMAL POWER
STATION UNIT NO. 3, STAGE-3**

BHEL DOCUMENTS NO.: PE-TS-367-174-14000A-A001

VOLUME II-B

SECTION -D3

REV. NO. 02

DATE: 04/12/2014

GENERAL TECHNICAL REQUIREMENTS FOR INSTRUMENTS

BHEL – PS - PPEI: NOIDA, SECTOR-16A, U.P. – 201301

FORM NO. PEM-6666-0

	DATA SHEET FOR TEMPERATURE ELEMENT (WITH THERMOWELL) Refer Specific Technical Requirement for details		SPECIFICATION NO.:	
			VOLUME	
			SECTION	
			REV. NO.	DATE:
			SHEET 1	OF 2
TAG No. Qty.....		Data Sheet No.: PES-145-03A-DS1-0		
Data Sheet A & B				
DATA SHEET-A FOR TEMPERATURE ELEMENT (WITH THERMOWELL) (TO BE FILLED BY PURCHASER)			DATA SHEET-B (TO BE FILLED-UP BY BIDDER)	
GENERAL	MANUFACTURER			
	MODEL NUMBER			
TECHNICAL	ELEMENT TYPE	<input type="checkbox"/> RTD (3 WIRE) <input type="checkbox"/> T / C		
	T / C GROUNDED	<input type="checkbox"/> YES <input type="checkbox"/> NO		
	ELEMENT THICKNESS (AWG)			
	LIMIT OF ERROR	Accuracy +/- 0.5 % of SPAN		
	INSULATION RESISTANCE	MORE THAN 5M OHM AT 100V DC		
	TIME CONSTANT			
	MOUNTING THREAD SIZE	Process connection M33 X 2 thread or 150 RF Flanged		
	CONDUIT THREAD SIZE			
	EXTENSION WIRE TYPE			
	THERMOWELL	<input type="checkbox"/> YES <input type="checkbox"/> NO		
	THERMOWELL LENGTH			
	LINE SIZE			
	PRESSURE RATING			
	TEMPERATURE RATING			
FLUID MEDIUM				
NAME			NAME	
SIGNATURE			SIGNATURE	
DATE			DATE	

FORM NO. PEM-6866-0

	DATA SHEET FOR TEMPERATURE TRANSMITTER		SPECIFICATION NO.:		
			VOLUME		
			SECTION		
			REV. NO.	DATE:	
			SHEET 1	OF	2
TAG No. Qty.....		Data Sheet No.: PES-145-03A-DS1-0			
Data Sheet C					
DATA SHEET-C FOR TEMPERATURE ELEMENT (WITH THERMOWELL) (TO BE FILLED BY CONTRACTOR AFTER AWARD OF CONTRACT)					
GENERAL	MANUFACTURER				
	MODEL NUMBER				
TECHNICAL	ELEMENT TYPE				
	T / C GROUNDED				
	ELEMENT THICKNESS (AWG)				
	LIMIT OF ERROR				
	INSULATION RESISTANCE				
	TIME CONSTANT				
	MOUNTING THREAD SIZE				
	CONDUIT THREAD SIZE				
	EXTENSION WIRE TYPE				
	THERMOWELL				
	THERMOWELL LENGTH				
	LINE SIZE				
	PRESSURE RATING				
	TEMPERATURE RATING				
FLUID MEDIUM					
NAME				NAME	
SIGNATURE				SIGNATURE	
DATE				DATE	

FORM NO. PEM-666-0

	SPECIFICATION FOR TEMPERATURE ELEMENT FOR AUX PACKAGE	SPECIFICATION NO.: PES – 145 – 003A		
		VOLUME	II B	
		SECTION	D	
		REV. NO.	01	DATE : 27.07.94
		SHEET	1	OF 3

1.0 TECHNICAL REQUIREMENTS

1.1 General

i) The temperature sensor elements shall be duplex type either thermocouple (T/C) or resistance temperature detector (RTD). Unless otherwise specified, the type of sensors for different applications shall be as follows:

ii) Nickel Chromium Nickel T/C medium temp. range (250°C to 600°C)

iii) Platinum-Rhodium Platinum High temp. range (600°C and above). Type S/R/B.

iv) Platinum RTD Low temperature & high accuracy (-50°C to 250°C).

1.2 Process Parameters

The instrument shall be suitable for a Process Parameters given in the instrument data sheet.

1.3 Thermocouple Wire Size

The thermocouple wire size for a given temperature application shall be as per table - 3.1A of ASME PTC 19.3 - 1974.

1.4 Sensor Grounding

As per instrument data sheet.

1.5 Sensor Protective Sheath & Wire Insulation

The sensor protective sheath shall be 8mm OD 316 SS seamless tube using compacted magnesium oxide packing/porcelain for insulation.

1.6 Sensor Characteristics

Thermocouple calibration characteristics i.e. temperature vs. milli volt or resistance shall be as per the applicable Indian Standards (IS-2054 for thermocouple 'K' type, IS-2055 for Pt.Rd.Pt.), RTD type of sensor calibration i.e. temperature vs. resistance shall be as per applicable Indian Standard (IS-2848).

1.7 Sensor Accuracy Limits

T/C sensor limiting accuracy shall be as per table 3.2A of ASME PTC 19.3 - 1974. RTD sensor accuracy shall be as per table 9.1 of ASME PTC - 19.3 - 74.

1.8 Insulation Resistance

Insulation resistance of RTD leads w.r.t. body shall be more than 5 mega ohms at 100V DC.

1.9 End Connection

The sensor assemblies shall have screwed M33 x 2 end connection. Specific design requirements of pressure, temperature and end connection type for a given application are indicated in the instrument data sheet.

FORM NO. PEM-6666-0

	SPECIFICATION FOR TEMPERATURE ELEMENT FOR AUX PACKAGE	SPECIFICATION NO.: PES – 145 – 003A		
		VOLUME	II B	
		SECTION	D	
		REV. NO.	01	DATE : 27.07.94
		SHEET	2	OF 3

1.10 Terminal Head

The terminal head cover shall be screwed type design having gasket with small flexible chain attached between fixed portion and head cover.

1.10.1 Terminal Head Enclosure

The terminal head enclosure shall be dust, weather proof and water proof as per NEMA-4 classification unless specified otherwise.

1.10.2 Terminals

The terminal head shall have provision of screwed terminal of 1.5 mm² size for external connection. The terminals shall be suitably marked '+ve' & '-ve' for thermocouple and 'Lo', 'Hi' and 'C' for three wire RTD.

1.11 Cable Entry

Cable gland complete with neoprene gromet suitable for PVC cable with maximum diameter of 17.5mm shall be provided for cable entry. The actual size of cable shall be indicated during the contract stage. Separate cable entry and cable glands shall be provided for both the elements.

1.12 Thermowell and its material

Temperature element shall be supplied along with the thermowell. The thermowell shall be of tungstion carbide for mill air temperature and for rest of the applications of AISI 316SS shall be machined out of solid bar stock and designed to suit the process conditions. For detail of the thermowell, see enclosed drawing.

1.12.1 Internal Construction

Sensor assemblies shall preferably be metal sheathed with spring load on to the thermowell tip for better response. The sheathed sensor assembly shall be replaceable (in-situ) type without removal of thermowell.

1.12.2 Compensating cable should be used for connecting elements to secondary Instruments/Device unless there is specific requirement for cold junction compensation. Field mounted cold junction compensation box as per NEMA-4 shall be provided for all thermocouples. The CJC box shall have automatic temperature control at reference junction temperature of 60°C. Each CJC box shall be provided with duplex RTD for remote monitoring.

2.0 TESTING

2.1 The bidder shall adopt suitable quality assurance program to ensure that the equipments offered will meet the specification requirements in full.

2.2 The vendor shall conduct following tests as a minimum requirement and shall furnish test certificate thereof, for BHEL's approval before despatch of the same.

2.2.1 Physical dimension of the sensor assemblies as per approved drawing.

2.2.2 Electrical characterstic of sensor such as continuity of the thermocouple wires, and insulation resistance of the RTD leads w.r.t. body.

FORM NO. PEM-6666-0

	SPECIFICATION FOR TEMPERATURE ELEMENT FOR AUX PACKAGE	SPECIFICATION NO.: PES – 145 – 003A		
		VOLUME	II B	
		SECTION	D	
		REV. NO.	01	DATE : 27.07.94
		SHEET	3	OF 3

2.2.3 Temperature vs. Resistance/milli volt for the sensor assemblies shall be tested with reference to standard resistance thermometer by comparison method. This test may be carried out once for the T/C or RTD sensor wires for each batch production.

2.2.4 Each type of high pressure thermowell assembly with thread and connection shall be tested against hydrostatic test pressure of one & a half times the maximum working pressure for any leakage. However dimensional checks and thread conformity with gauges shall be checked for each sensor assembly.

3.0 APPLICABLE DATA SHEET FORMS

This document shall be read with one or more of the following data sheet forms :

- Data sheet A&B for Temperature Element (With Thermowell) : Data sheet no. PES-145-03A-DS1-0
- Data sheet C for Temperature Element (With Thermowell) : Data sheet no. PES-145-03A-DS2-0

FORM NO. PEM - 6866-D



THERMOWELL MEDIUM PRESSURE
(40 Kgf/Cm²)

SPECIFICATION NO PES-145-03A

VOLUME IIB

SECTION D

REV. NO. 01

DATE 27-7-94

SHEET 4

OF 8

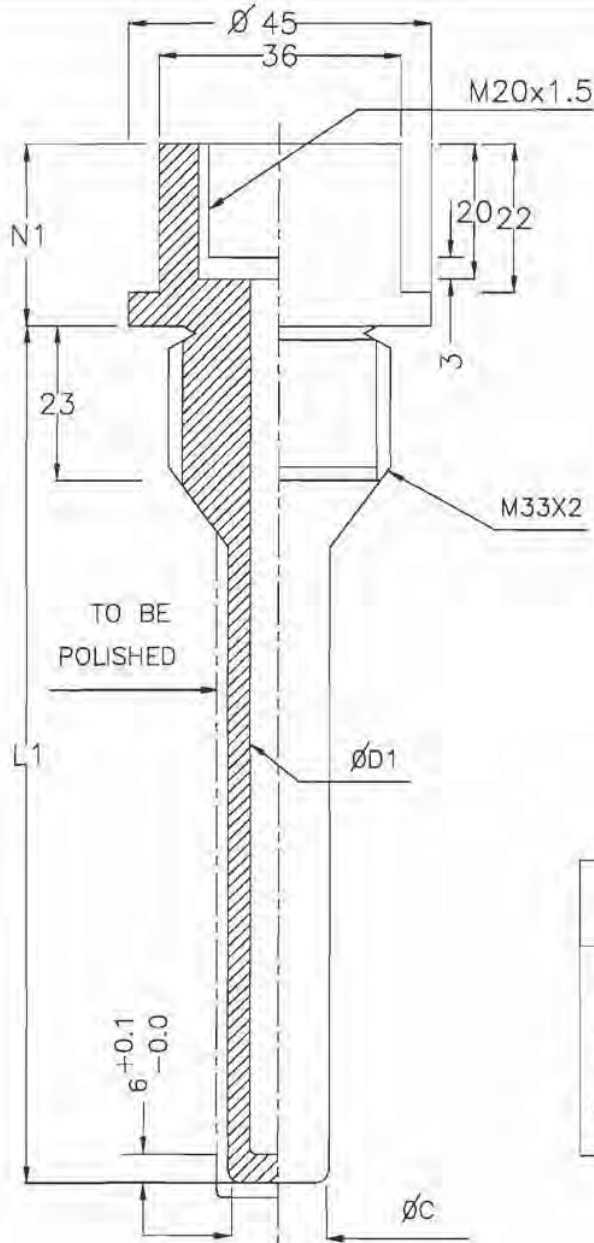

PIPE O.D.	INSERTION LENGTH (L1)
̸ 509 & ABOVE	325
̸ 506 TO 369	250
̸ 368 TO 274	175
* ̸ 273 BELOW	150

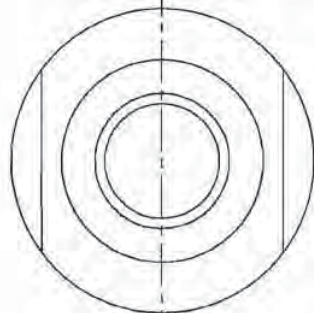

Fig.1

* FOR PIPE O.Ds UP TO 159mm THE THERMOWELL INSERTION WILL BE STRAIGHT. FOR PIPE O.Ds BELOW 159mm, THE INSERTION SHALL BE SLANT.

FORM NO. - 6666-0



**SPECIFICATION FOR TEMPERATURE
ELEMENT (WITH THERMOWELL)**

SPECIFICATION NO. : PES - 145 - 03A

VOLUME II B

SECTION D

REV. NO. 01 DATE 27.07.94

SHEET 5 OF 8

**THERMOWELL-MEDIUM PRESSURE
(40 KG/CM²)**

ALL DIMENSIONS IN mm

Instrument stem dia D+0.0 -0.1	DIA D1 +0.2 0	DIA C	Insertion Length L1	Extention element length N1	Corres ponding element length(L)
6	6.5	12.5	150	27	171
				75	219
				100	244
			175	27	196
				75	244
				100	269
			250	27	271
				75	319
				100	344
			325	27	346
				75	394
				100	419
8	8.5	15	150	27	171
				75	219
				100	244
			175	27	196
				75	244
				100	269
			250	27	271
				75	319
				100	344
			325	27	346
				75	394
				100	419

FORM NO. - 6666-0

	SPECIFICATION FOR TEMPERATURE ELEMENT (WITH THERMOWELL)	SPECIFICATION NO. : PES - 145 - 03A	
		VOLUME II B	
		SECTION D	
		REV. NO. 01	DATE 27.07.94
		SHEET 6	OF 8

ALL DIMENSIONS IN mm

Instrument stem dia D+0.0 -0.1	DIA D1 +0.2 0	DIA C	Insertion Length L1	Extention element length N1	Corres ponding element length(L)
12	12.5	19	150	27	171
				75	219
				100	244
			175	27	196
				75	244
				100	269
			250	27	271
				75	319
				100	344
			325	27	346
				75	394
				100	419
14	14.5	21	150	27	171
				75	219
				100	244
			175	27	196
				75	244
				100	269
			250	27	271
				75	319
				100	344
			325	27	346
				75	394
				100	419

NOTE: The corresponding element lengths are given for information only. The elements lengths are worked out as per the formula :

$$L = L1 + N1 - 6$$

FORM NO. PEM - 8666-D



THERMOWELL-HIGH PRESSURE
(250 Kg/Cm²)

SPECIFICATION NO. PES-145-03A

VOLUME IIB

SECTION D

REV. NO. 01

DATE 27-7-94

SHEET 7

OF 8

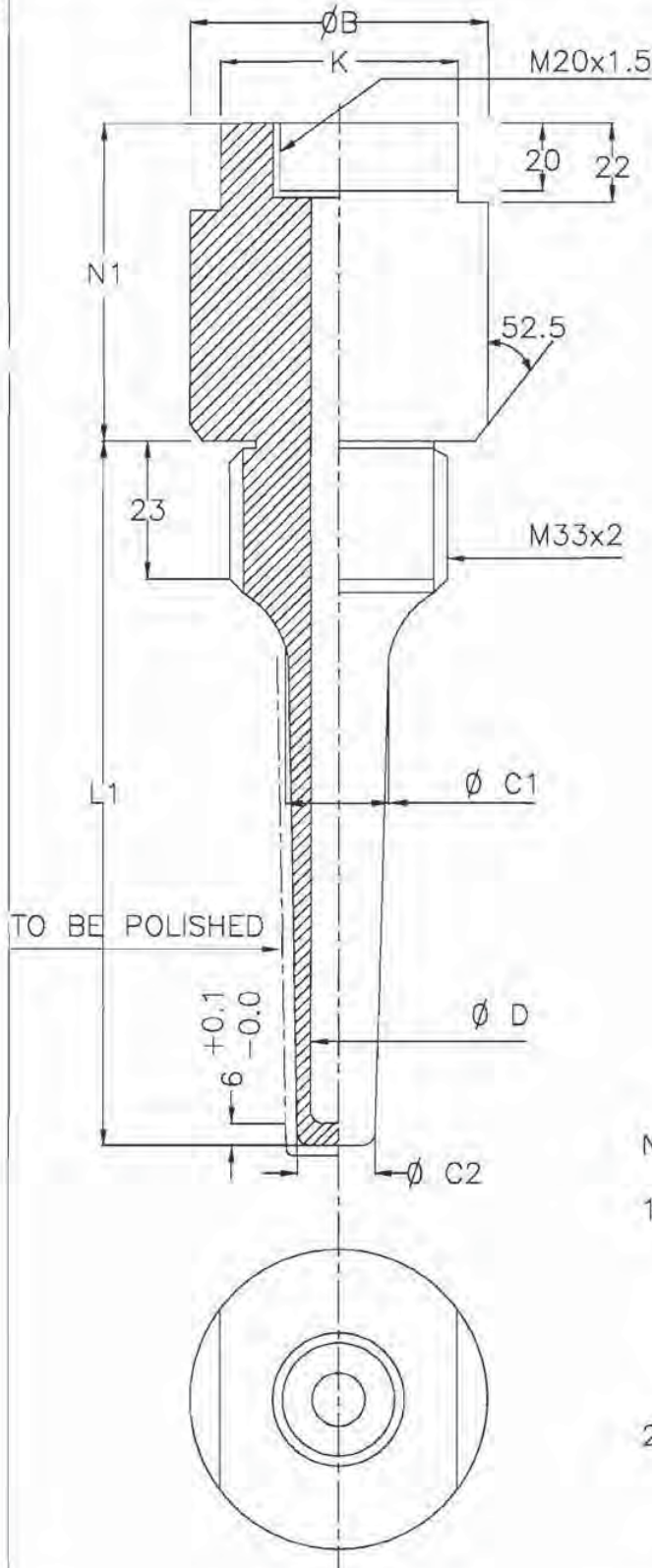

PIPE O.D.	INSERTION LENGTH L1
Ø 509 & ABOVE	325
Ø 508 TO 368	250
Ø 367 TO 0274	175
Ø 273 BELOW	150

NOTE :-

1. THE CORRESPONDING ELEMENT ELEMENT LENGTHS ARE GIVEN FOR INFORMATION ONLY. THE ELEMENT LENGTHS ARE WORKOUT AS PER THE FORMULA $L=L1+N1-6$.
2. FOR PIPE OD'S UPTO 159mm, THE THERMOWELL INSERTION WILL BE STRAIGHT. FOR PIPE OD'S BELOW 159mm, THE INSERTION SHALL BE SLANT.

Fig. 2

FORM NO. - 6666-0

	SPECIFICATION FOR TEMPERATURE ELEMENT (WITH THERMOWELL)	SPECIFICATION NO. : PES - 145 - 03A	
		VOLUME II B	
		SECTION D	
		REV. NO. 01	DATE 27.07.94
		SHEET 8	OF 8

ALL DIMENSIONS IN mm

Instrument stem dia D (+0.0 -0.1)	DIA D1 (+0.2 0.0)	DIA C1	DIA C2	K	DIA B	Insertion Length L1	Extention Length N1	Corresponding Element Length (L)
6	6.5	19	12.5	36	45	150	27 75 100	171 219 244
						250	27 75 100	271 319 344
8	8.5	21.5	15	36	45	150	27 75 100	171 219 244
						250	27 75 100	271 319 344
12	12.5	25.5	19	36	45	150	27 75 100	171 219 244
						250	27 75 100	271 319 344
14	14.5	27.5	21	36	45	150	27 75 100	171 219 244
						250	27 75 100	271 319 344
16	16.5	29	23	46	55	150	27 75 100	171 219 244
						250	27 75 100	271 319 344

FORM NO. PEM-6866-0

	CHECK LIST FOR PRESSURE / DIFFERENTIAL PRESSURE GAUGE (MECHANICAL AUXILIARY PACKAGES)	SPECIFICATION NO.: PE-TS-375-145-I054	
		VOLUME	
		SECTION	
		REV. NO. 00	DATE: 15.02.2012
		SHEET 16	OF 16

SL NO	TESTS/CHECKS	QUANTM OF CHECK	REFERENCE DOC. ACCEPTANCE NORMS	AGENCY			REMARKS
				P	W	V	
1.0	CHECK FOR		APPROVED TECHINICAL REQUIREMENT/ DATA SHEET				MFR TO CARRY OUT ROUTINE TEST ON 100%. WHEN MATL CORELATION ARE NOT AVAILABLE MFR'S COMPLIANCE TO BE PROVIDED
	1.1 DIAL SIZE	100%		M	C	C	
	1.2 MODEL NO/TAG NO	100%		M	C	C	
	1.3 RANGE/SCALE	100%		M	C	C	
	1.4 END CONNECTION	100%		M	C	C	
	1.5 SWITCH CONTACT RATING & NOS	100%		M	C	C	
2.0	CALIBRATION						
	2.1 ACCURACY	100%		M	C	B	
	2.2 REPEATABILITY (FOR SWITCH)	100%		M	C	B	
	2.3 SET POINT ADJUSTMENT FOR SWITCH	100%		M	C	C	
3.0	OVER PRESSURE & LEAK TEST	100%		M	C	C	
4.0	OPERATION OF PR. RELEIF DEVICE	ONE PER TYPE		M	C	C	
5.0	REVIEW OF T.C. FOR MATERIAL OF--						
	5.1 SENSOR	FOR LOT		-	-	B	
	5.2 MOVEMENT			-	-	B	
	5.3 PROCESS CONNECTION		-	-	B		
	5.4 HOUSING		-	-	B		
6.0	REVIEW OF T.C. FOR DEGREE OF PROTECTION	TYPE TEST	-	-	B		
7.0	REVIEW OF T.C. FOR CONTACT RATING OF SWITCH	ONE PER TYPE	-	-	B		
8.0	ACCESSORIES AS APPLICABLE	100%	M	C	C		

LEGEND:

M: MANUFACTURER/ SUB CONTRACTOR, C: CONTRACTOR/ NOMINATED INSP AGENCY, B: BHEL. P: PERFORM, W: WITNESS, V: VERIFICATION.

NOTE:

CONTRACTOR TO PROVIDE COMPLIANCE CERTIFICATE FOR TESTS/CHECKS VERIFIED BY CONTRACTOR AND SUBMIT THE SAME ALONGWITH TEST CERTIFICATES TO BE VERIFIED BY BHEL.

FORM NO. PEM-6666-0

	DATA SHEET FOR PRESSURE / DIFFERENTIAL PRESSURE GAUGE Refer Specific Technical Requirement for details		SPECIFICATION NO.:
			VOLUME
			SECTION
			REV. NO. DATE:
TAG No. Qty.....		Data Sheet No.: PE-DC-999-145-I026	
Data Sheet A & B			
DATA SHEET-A FOR PRESSURE / DIFFERENTIAL PRESSURE GAUGE (TO BE FILLED BY PURCHASER)			DATA SHEET-B (TO BE FILLED-UP BY BIDDER)
GENERAL	MANUFACTURER		
	MODEL NUMBER		
TECHNICAL	PRESSURE ELEMENT	<input checked="" type="checkbox"/> BOURDON <input type="checkbox"/> DIAPHRAGM <input type="checkbox"/> BELLOW	
	MATERIAL	SENSING ELEMENT – AISI 316 SS MOVEMENT – AISI 304 SS Refer Specific Technical Requirement for details	
	ENCLOSURE	<input type="checkbox"/> IP-55 <input checked="" type="checkbox"/> IP-65 <input type="checkbox"/> FUEL GAS HAZARDOUS APPL. EXPL. PROOF	
	DIAL	SIZE: <input type="checkbox"/> 100MM <input checked="" type="checkbox"/> 150MM COLOR: WHITE NUMERALS: BLACK SCALE: <input checked="" type="checkbox"/> LINEAR <input type="checkbox"/> SQUARE ROOT	
	CASE	COLOUR : BLACK	
	ADJUSTMENT	<input checked="" type="checkbox"/> EXT. MICROMETER SCREW <input type="checkbox"/> INT. MICRO SCREW	
	MOUNTING	<input checked="" type="checkbox"/> LOCAL <input type="checkbox"/> PANEL OR RACK	
	OVER RANGE PROTECTION	<input checked="" type="checkbox"/> 150% OF MAX. PRESSURE <input type="checkbox"/> 125% ABOVE 150 KG/CM2 FSD <input type="checkbox"/> AS REQUIRED	
	BLOW OUT DISC	SUITABLE MATERIAL	
	SWITCHING FACILITY NO./TYPE OF CONTACTS CONTACT RATINGS SETTING RANGE REPEATABILITY POWER SUPPLY	Refer Specific Technical Requirement for details	
PERFORMANCE	ACCURACY	± 0.5% OR BETTER OF FULL SCALE DEFLECTION	
CONNECTION	PROCESS	AS APPLICABLE	
	LOCATION	<input type="checkbox"/> BACK <input type="checkbox"/> BOTTOM <input checked="" type="checkbox"/> AS REQUIRED	
ACCESSORIES	NAME PLATE / METAL TAG	SS	
	MOUNTING	<input type="checkbox"/> WALL <input checked="" type="checkbox"/> PIPE – U CLAMPS & BOLTS <input type="checkbox"/> PANEL / RACK <input type="checkbox"/> AS REQUIRED	
	OTHER	Refer Specific Technical Requirement for details	
NAME			NAME
SIGNATURE			SIGNATURE
DATE			DATE

FORM NO. PEM-6866-0

	DATA SHEET FOR PRESSURE / DIFFERENTIAL PRESSURE GAUGE		SPECIFICATION NO.:	
			VOLUME	
			SECTION	
			REV. NO.	DATE:
			SHEET 1	OF 1
TAG No. Qty.....		Data Sheet No.: PE-DC-999-145-I026		
Data Sheet C				
DATA SHEET-C FOR PRESSURE / DIFFERENTIAL PRESSURE GAUGE (TO BE FILLED BY CONTRACTOR AFTER AWARD OF CONTRACT)				
GENERAL	MANUFACTURER			
	MODEL NUMBER			
TECHNICAL	PRESSURE ELEMENT			
	MATERIAL			
	ENCLOSURE			
	DIAL			
	CASE			
	ADJUSTMENT			
	MOUNTING			
	OVER RANGE PROTECTION			
	BLOW OUT DISC			
	SETTING RANGE			
PERFORMANCE	ACCURACY			
CONNECTION	PROCESS			
	LOCATION			
ACCESSORIES	NAME PLATE / METAL TAG			
	MOUNTING			
	OTHER			
NAME SIGNATURE DATE				NAME
				SIGNATURE
				DATE

FORM NO. PEM-6866-0

	DATA SHEET FOR PRESSURE / DIFFERENTIAL PRESSURE TRANSMITTER		SPECIFICATION NO.:	
			VOLUME	
			SECTION	
			REV. NO.	DATE:
			SHEET 1	OF 4
TAG No. Qty.....		Data Sheet No.: PES-145-01-DS1-0		
Data Sheet A & B				
DATA SHEET-A FOR PRESSURE / DIFFERENTIAL PRESSURE TRANSMITTER (TO BE FILLED BY PURCHASER)			DATA SHEET-B (TO BE FILLED-UP BY BIDDER)	
GENERAL	MANUFACTURER			
	MODEL NUMBER			
TECHNICAL	TYPE	<input type="checkbox"/> INDUCTANCE <input type="checkbox"/> CAPACITANCE <input type="checkbox"/> STRAIN GAUGE <input type="checkbox"/>		
	POWER SUPPLY	24V DC		
	TRANSMITTER MEASUREMENT	<input type="checkbox"/> PRESSURE <input type="checkbox"/> DIFF. PRESSURE		
	OUTPUT SIGNAL	4-20MA		
	NO. OF WIRE	TWO		
	ACCURACY	± 0.5% OF SPAN		
	LINEARITY, HYSTERISIS, DEAD BAND AND REPEATABILITY	± 0.1% OF SPAN		
	STABILITY	± 0.25% OF SPAN OR BETTER FOR 6 MONTHS		
	SENSITIVITY	± 0.05% OF SPAN		
	<u>MATERIAL</u>			
	A) BODY	FORGED CARBON STEEL		
	B) ELEMENT	316 SS		
	C) SEAL	TEFLON		
	CONTINUOUSLY ADJUSTABLE SPAN AND ZERO ADJUSTMENT PROVIDED	<input type="checkbox"/> YES <input type="checkbox"/> NO		
	MOUNTING	<input type="checkbox"/> WALL/PIPE STAND <input type="checkbox"/> TRANSMITTER RACK		
	ENCLOSURE	<input type="checkbox"/> NEMA-4 <input type="checkbox"/> NEMA-7		
	TURN DOWN RATIO	TO BE SPECIFIED BY BIDDER		
	INSULATION RESISTANCE	TO BE SPECIFIED BY BIDDER		
	ZERO SUPPRESSION RANGE	TO BE SPECIFIED BY BIDDER		
	ZERO ELEVATION RANGE	TO BE SPECIFIED BY BIDDER		
INTEGRAL INDICATOR	<input type="checkbox"/> YES <input type="checkbox"/> NO			

FORM NO. PEM-6866-0

	DATA SHEET FOR PRESSURE / DIFFERENTIAL PRESSURE TRANSMITTER			SPECIFICATION NO.:	
				VOLUME	
				SECTION	
				REV. NO.	DATE:
				SHEET 2	OF 4
TAG No. Qty.....			Data Sheet No.: PES-145-01-DS1-0		
Data Sheet A & B					
DATA SHEET-A FOR PRESSURE / DIFFERENTIAL PRESSURE TRANSMITTER (TO BE FILLED BY PURCHASER)				DATA SHEET-B (TO BE FILLED-UP BY BIDDER)	
	TRANSMITTER SHALL BE ABLE TO DRIVE OUTPUT IMPEDANCE OF 500 OHMS.	YES			
	ZERO DRIFT	< 0.1%			
	SPAN DRIFT	< 0.1%			
	<u>MANIFOLD</u>				
	a) PRESSURE MEASUREMENT	3 WAY			
	B) DIFFERENTIAL PRESSURE MEASUREMENT	5 WAY			
	CABLE ENTRY DETAIL	SUITABLE FOR DIA OF 17.5 mm			
NAME SIGNATURE DATE	PREPARED BY	CHECKED BY	APPROVED BY	COMPANY SEAL	
				NAME	
				SIGNATURE	
				DATE	

FORM NO. PEM-6866-0

	DATA SHEET FOR PRESSURE / DIFFERENTIAL PRESSURE TRANSMITTER		SPECIFICATION NO.:	
			VOLUME	
			SECTION	
			REV. NO.	DATE:
			SHEET 1	OF 2
TAG No. Qty.....		Data Sheet No.: PES-145-01-DS2-0		
Data Sheet C				
DATA SHEET-C FOR PRESSURE / DIFFERENTIAL PRESSURE TRANSMITTER (TO BE FILLED BY CONTRACTOR AFTER AWARD OF CONTRACT)				
GENERAL	MANUFACTURER			
	MODEL NUMBER			
TECHNICAL	TYPE			
	POWER SUPPLY			
	TRANSMITTER MEASUREMENT			
	OUTPUT SIGNAL			
	NO. OF WIRE			
	ACCURACY			
	LINEARITY, HYSTERISIS, DEAD BAND AND REPEATABILITY			
	STABILITY			
	SENSITIVITY			
	<u>MATERIAL</u>			
	A) BODY			
	B) ELEMENT			
	C) SEAL			
	CONTINUOUSLY ADJUSTABLE SPAN AND ZERO ADJUSTMENT PROVIDED			
	MOUNTING			
	ENCLOSURE			
	TURN DOWN RATIO			
INSULATION RESISTANCE				
ZERO SUPPRESSION RANGE				
ZERO ELEVATION RANGE				
INTEGRAL INDICATOR				

FORM NO. PEM-6866-0

	DATA SHEET FOR PRESSURE / DIFFERENTIAL PRESSURE TRANSMITTER			SPECIFICATION NO.:	
				VOLUME	
				SECTION	
				REV. NO.	DATE:
				SHEET 2	OF 2
TAG No. Qty.....			Data Sheet No.: PES-145-01-DS2-0		
Data Sheet C					
DATA SHEET-C FOR PRESSURE / DIFFERENTIAL PRESSURE TRANSMITTER (TO BE FILLED BY CONTRACTOR AFTER AWARD OF CONTRACT)					
	TRANSMITTER SHALL BE ABLE TO DRIVE OUTPUT IMPEDANCE OF 500 OHMS.				
	ZERO DRIFT				
	SPAN DRIFT				
	<u>MANIFOLD</u>				
	b) PRESSURE MEASUREMENT				
	B) DIFFERENTIAL PRESSURE MEASUREMENT				
	CABLE ENTRY DETAIL				
NAME SIGNATURE DATE	PREPARED BY	CHECKED BY	APPROVED BY	COMPANY SEAL	
				NAME	
				SIGNATURE	
				DATE	

FORM NO. PEM-6666-0

	DATA SHEET FOR TEMPERATURE GAUGE			SPECIFICATION NO.:	
				VOLUME	
				SECTION	
				REV. NO.	DATE:
				SHEET 1	OF 2
TAG No. Qty.....			Data Sheet No.: PES-145-27-DS1-0		
Data Sheet A & B					
DATA SHEET-A FOR TEMPERATURE GAUGE (TO BE FILLED BY PURCHASER)				DATA SHEET-B (TO BE FILLED-UP BY BIDDER)	
GENERAL	MANUFACTURER				
	MODEL NUMBER				
TECHNICAL	TYPE - MERCURY FILLED		<input type="checkbox"/> RIGID STEM <input type="checkbox"/> CAPILLARY		
	PRESSURE ELEMENT		BOURDON		
	<u>MATERIAL</u>				
	PRESSURE ELEMENT		<input type="checkbox"/> AISI 316 SS <input type="checkbox"/> CR-MO STEEL		
	CASE		<input type="checkbox"/> DIE CAST AL		
	BULB & CAPILLARY		<input type="checkbox"/> AISI 316 SS		
	CAPILLARY ARMOUR		<input type="checkbox"/> SS 316 <input type="checkbox"/> FLEXIBLE		
	MOVEMENT		<input type="checkbox"/> AISI 304 SS		
	THERMOWELL		<input type="checkbox"/> AISI 316 SS <input type="checkbox"/> CR.MO. STEEL <input type="checkbox"/> SCREWED TYPE <input type="checkbox"/> WELDED TYPE		
	ENCLOSURE		<input type="checkbox"/> INDOOR MOUNTED IP-55 <input type="checkbox"/> OUTDOOR MOUNTED IP-67 <input type="checkbox"/> FUEL GAS HAZARDOUS APPL. EXPL. PROOF		
	DIAL		SIZE : <input type="checkbox"/> 100MM <input type="checkbox"/> 150MM <input type="checkbox"/> 250MM COLOUR: <input type="checkbox"/> WHITE CASE : <input type="checkbox"/> BLACK NUMERALS: <input type="checkbox"/> BLACK		
	MOUNTING & CONNECTION		<input type="checkbox"/> DIRECT MOUNTED <input type="checkbox"/> PANEL OR RACK MOUNTED		
	COMPENSATION		CASE COMP.		
	ZERO ADJUSTER		PROVIDED		
CAPILLARY LENGTH		5.0 METERS (FOR LOCAL MOUNTED) 15.0 METERS (FOR PANEL/RACK MOUNTING)			
PERFORMANCE	ACCURACY		± 1% OR BETTER OF FULL SCALE DEFLECTION		
	TEMPERATURE GAUGE CONNECTION		M20X1.5(M)		
CONNECTION	LOCATION		BACK		
	THERMOWELL		<input type="checkbox"/> YES <input type="checkbox"/> FORGED BAR STACK TYPE		
	THERMOWELL CONNECTION		<input type="checkbox"/> M20X1.5 INTERNAL <input type="checkbox"/> M33X2 EXTERNAL <input type="checkbox"/> DESIGN CODE: ASME PTC		
	NAME		PREPARED BY		CHECKED BY
SIGNATURE					
DATE					
					COMPANY SEAL

FORM NO. PEM-6866-0

	DATA SHEET FOR PRESSURE / DIFFERENTIAL PRESSURE TRANSMITTER			SPECIFICATION NO.:	
				VOLUME	
				SECTION	
				REV. NO.	DATE:
				SHEET 1	OF 2
TAG No. Qty.....			Data Sheet No.: PES-145-27-DS2-0		
Data Sheet C					
DATA SHEET-C FOR TEMPERATURE GAUGE (TO BE FILLED BY CONTRACTOR AFTER AWARD OF CONTRACT)					
GENERAL	MANUFACTURER				
	MODEL NUMBER				
TECHNICAL	TYPE - MERCURY FILLED				
	PRESSURE ELEMENT				
	<u>MATERIAL</u>				
	PRESSURE ELEMENT				
	CASE				
	BULB & CAPILLARY				
	CAPILLARY ARMOUR				
	MOVEMENT				
	THERMOWELL				
	ENCLOSURE				
	DIAL				
	MOUNTING & CONNECTION				
	PERFORMANCE	ACCURACY			
TEMPERATURE GAUGE CONNECTION					
CONNECTION	LOCATION				
	THERMOWELL				
	THERMOWELL CONNECTION				
NAME SIGNATURE DATE	PREPARED BY	CHECKED BY	APPROVED BY	COMPANY SEAL NAME SIGNATURE DATE	

FORMAT NO. - 6666-0



SPECIFICATION FOR TEMPERATURE GAUGE

SPECIFICATION NO. : PES - 145 - 27A	
VOLUME II B	
SECTION D	
REV. NO. 01	DATE 27.07.94
SHEET 4 OF 7	

**THERMOWELL-MEDIUM PRESSURE
(40 KG/CM2)**

ALL DIMENSIONS IN mm

Instrument stem dia D+0.0 -0.1	DIA D1 +0.2 0	DIA C	Insertion Length L1	Extention element length N1	Corres ponding element length(L)
6	6.5	12.5	150	27	171
				75	219
				100	244
			175	27	196
				75	244
				100	269
			250	27	271
				75	319
				100	344
			325	27	346
				75	394
				100	419
8	8.5	15	150	27	171
				75	219
				100	244
			175	27	196
				75	244
				100	269
			250	27	271
				75	319
				100	344
			325	27	346
				75	394
				100	419

FORMAT NO. - 6666-0

	SPECIFICATION FOR TEMPERATURE GAUGE	SPECIFICATION NO. : PES - 145 - 27A	
		VOLUME II B	
		SECTION D	
		REV. NO. 01	DATE 27.07.94
		SHEET 5	OF 7

ALL DIMENSIONS IN mm -

Instrument stem dia D+0.0 -0.1	DIA D1 +0.2 0	DIA C	Insertion Length L1	Extention element length N1	Corres ponding element length(L)
12	12.5	19	150	27	171
				75	219
				100	244
			175	27	196
				75	244
				100	269
			250	27	271
				75	319
				100	344
			325	27	346
				75	394
				100	419
14	14.5	21	150	27	171
				75	219
				100	244
			175	27	196
				75	244
				100	269
			250	27	271
				75	319
				100	344
			325	27	346
				75	394
				100	419

NOTE: The corresponding element lengths are given for information only. The elements lengths are worked out as per the formula :

$$L = L1 + N1 - 6$$

FORM NO. PEM - 6666-0



THERMOWELL-HIGH PRESSURE
(250 Kgf/Cm²)

SPECIFICATION NO. PES-145-27A

VOLUME IIB

SECTION D

REV. NO. 01

DATE 27-7-94

SHEET 6

OF 7

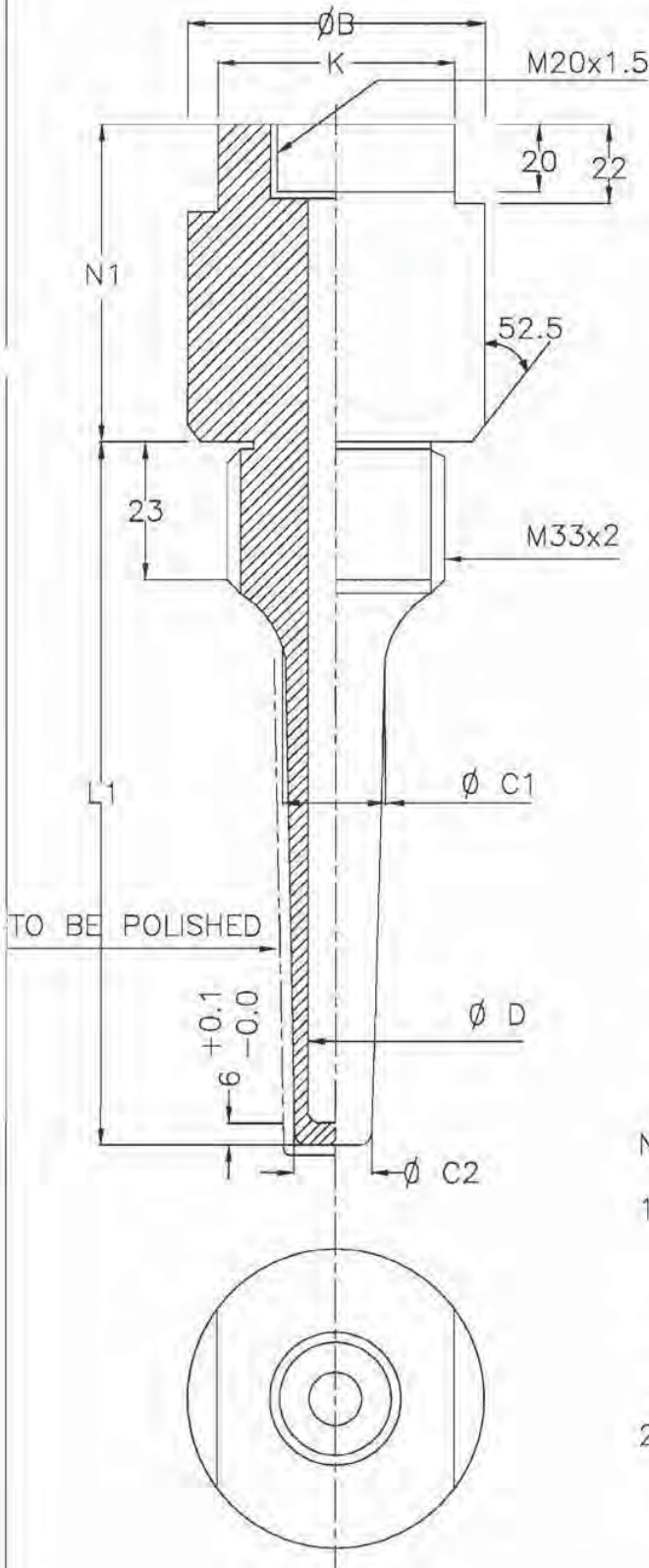

PIPE O.D.	INSERTION LENGTH L1
Ø 509 & ABOVE	325
Ø 508 TO 368	250
Ø 367 TO 274	175
Ø 273 BELOW	150

NOTE :-

1. THE CORRESPONDING ELEMENT ELEMENT LENGTHS ARE GIVEN FOR INFORMATION ONLY. THE ELEMENT LENGTHS ARE WORKOUT AS PER THE FORMULA $L=L1+N1-6$.
2. FOR PIPE OD'S UPTO 159mm, THE THERMOWELL INSERTION WILL BE STRAIGHT. FOR PIPE OD'S BELOW 159mm, THE INSERTION SHALL BE SLANT.

Fig. 2

FORMAT NO. - 6666-0

	SPECIFICATION FOR TEMPERATURE GAUGE	SPECIFICATION NO. : PES - 145 - 27A	
		VOLUME II B	
		SECTION D	
		REV. NO. 01	DATE 27.07.94
		SHEET 7 OF 7	

ALL DIMENSIONS IN mm

Instrument stem dia D (+0.0 -0.1)	DIA D1 (+0.2 0.0)	DIA C1	DIA C2	K	DIA B	Insertion Length L1	Extention Length N1	Corresponding Element Length (L)
6	6.5	19	12.5	36	45	150	27 75 100	171 219 244
						250	27 75 100	271 319 344
8	8.5	21.5	15	36	45	150	27 75 100	171 219 244
						250	27 75 100	271 319 344
12	12.5	25.5	19	36	45	150	27 75 100	171 219 244
						250	27 75 100	271 319 344
14	14.5	27.5	21	36	45	150	27 75 100	171 219 244
						250	27 75 100	271 319 344
16	16.5	29	23	46	55	150	27 75 100	171 219 244
						250	27 75 100	271 319 344



TITLE:

**TECHNICAL SPECIFICATION FOR
OZONE GENERATION PLANT**

**1X700 MW BELLARY THERMAL POWER
STATION UNIT NO. 3, STAGE-3**

BHEL DOCUMENTS NO.: PE-TS-367-174-14000A-A001

VOLUME II-B

SECTION -D3

REV. NO. 02

DATE: 04/12/2014

GENERAL TECHNICAL REQUIREMENTS FOR PLC

BHEL – PS - PPEI: NOIDA, SECTOR-16A, U.P. – 201301

FORM NO. PEM-6866-0

 <p style="margin-top: 10px;">DATA SHEET FOR PLC SYSTEM 1 X 700 MW BELLARY</p>	SPECIFICATION NO.:	
	VOLUME	II B
	SECTION	D
	REV. NO. 02	DATE: 19.07.2008
	SHEET	1 OF 1
Data Sheet No.: PES-145-36-DS1-0		
Data Sheet A & B		
DATA SHEET-A FOR PLC SYSTEM (TO BE FILLED BY PURCHASER)		DATA SHEET – B (TO BE FILLED BY BIDDER)

GENERAL	PROJECT	1 X 700 MW BELLARY
	SERVICE	OZONE GENERATION PLANT
	QUANTITY	<input checked="" type="checkbox"/> UNITISED <input type="checkbox"/> COMMON
	LOCATION	<input checked="" type="checkbox"/> INDOOR <input type="checkbox"/> OUTDOOR
PLC EQUIPMENT	MAKE / MODEL NO.	BIDDER TO INDICATE
	PROCESSOR	REDUNDANT WITH HOT STANDBY
	DATA BUS (HMI)	<input type="checkbox"/> COPPER WIRE <input type="checkbox"/> FIBRE OPTIC
	DATA BUS (I/O - CPU)	<input type="checkbox"/> COPPER WIRE <input type="checkbox"/> FIBRE OPTIC
	DATA BUS (REMOTE I/O - CPU)	<input type="checkbox"/> COPPER WIRE <input type="checkbox"/> FIBRE OPTIC
	FIELD CONTACTS INTERROGATION VOLTAGE	<input checked="" type="checkbox"/> 24 V <input type="checkbox"/> 48 V
	LOCATION OF COUPLING RELAYS	<input checked="" type="checkbox"/> MCC <input type="checkbox"/> PLC PANEL
	DESKTOP OWS QUANTITY	<input type="checkbox"/> ONE <input type="checkbox"/> TWO <input checked="" type="checkbox"/> 1 No. LCD
	DESKTOP MONITOR TYPE	<input type="checkbox"/> 19" <input type="checkbox"/> 21" TFT/CRT MONITOR
	PRINTER (A4) - QUANTITY	INKJET _____ LASER B/W _____ 1 No COLOR INKJET _____ COLOR LASER _____
	PRINTER (A4) - MODEL	INKJET _____ LASER B/W _____ COLOR INKJET _____ COLOR LASER _____
PROGRAMMING / CONFIGURATION FACILITY	A) <input type="checkbox"/> HAND HELD B) <input type="checkbox"/> ENGINEERING SOFTWARE <input type="checkbox"/> ONE OWS <input type="checkbox"/> ALL OWS <input type="checkbox"/> _____	
SAFETY STANDARD	_____	
	COMPUTER FURNITURE	<input type="checkbox"/> YES <input type="checkbox"/> NO
PANEL	QUANTITY	BIDDER TO INDICATE
	CLASS OF PROTECTION	<input checked="" type="checkbox"/> IP 65
	REMOTE I/O PANEL	<input type="checkbox"/> YES <input checked="" type="checkbox"/> NO
	COLOUR	AS PER IS-5 SHADE _____
	BACK-UP	<input checked="" type="checkbox"/> YES <input type="checkbox"/> NO
	MIMIC	<input checked="" type="checkbox"/> YES <input type="checkbox"/> NO
	CONTROL HARDWARE	<input checked="" type="checkbox"/> PB <input checked="" type="checkbox"/> INDICATORS <input type="checkbox"/> FACIAS _____ Nos. <input type="checkbox"/> OTHERS
COMMUNICATION TO OTHER SYSTEM	HARDWIRED	<input type="checkbox"/> YES <input checked="" type="checkbox"/> NO
	PURPOSE	<input type="checkbox"/> CONTROL <input checked="" type="checkbox"/> MONITORING
	MEDIUM	<input type="checkbox"/> UTP <input checked="" type="checkbox"/> FIBRE OPTIC <input type="checkbox"/> OTHERS
	TIME SYNCRONIZATION SIGNAL FORMAT	<input type="checkbox"/> PULSE <input type="checkbox"/> RS-485 <input checked="" type="checkbox"/> IRIG-B
	SOFTLINK	<input type="checkbox"/> MODBUS <input type="checkbox"/> OPC
	SERIAL LINK	COMMUNICATION PORT TYPE _____
POWER SUPPLY INPUT FEEDER	PLC PANEL	BIDDER TO INDICATE LOAD DATA
	REMOTE I/O PANEL	BIDDER TO INDICATE LOAD DATA

FORM NO. PEM-6866-0

	DATA SHEET FOR PLC SYSTEM		SPECIFICATION NO.:	
			VOLUME II B	
			SECTION D	
			REV. NO. 02	DATE: 19.07.2008
			SHEET 1	OF 1
Data Sheet No.: PES-145-36-DS2-0				
Data Sheet C				
DATA SHEET – C (TO BE FILLED BY BIDDER AFTER AWARD OF CONTRACT)				
GENERAL*	PROJECT			
	SERVICE			
	QUANTITY			
	LOCATION			
PLC EQUIPMENT	MAKE / MODEL NO.			
	PROCESSOR			
	DATA BUS (HMI)			
	DATA BUS (I/O - CPU)			
	DATA BUS (REMOTE I/O - CPU)			
	FIELD CONTACTS INTERROGATION VOLTAGE			
	LOCATION OF COUPLING RELAYS			
	DESKTOP OWS QUANTITY			
	DESKTOP MONITOR TYPE			
	PRINTER (A4) - QUANTITY			
	PRINTER (A4) - MODEL			
	PROGRAMMING / CONFIGURATION FACILITY			
	SAFETY STANDARD			
		COMPUTER FURNITURE		
PANEL	QUANTITY			
	CLASS OF PROTECTION			
	REMOTE I/O PANEL			
	COLOUR			
	BACK-UP DESK			
	MIMIC			
	CONTROL HARDWARE			
COMMUNICATION TO OTHER SYSTEM	HARDWIRED			
	PURPOSE			
	MEDIUM			
	TIME SYNCHRONIZATION SIGNAL FORMAT			
	SOFTLINK			
	SERIAL LINK			
POWER SUPPLY INPUT FEEDER	PLC PANEL			
	REMOTE I/O PANEL			

	TITLE: SPECIFICATION FOR PROGRAMMABLE LOGIC CONTROLLER SYSTEM	SPECIFICATION NO. PES-145-36	
		VOLUME II-B	
		SECTION D	
		REV. NO. 02	DATE: July 19, 2008
		SHEET 1	OF 9

1. SCOPE

This specification covers the Design, Manufacture, Assembly, Inspection and Testing at manufacturer's works, proper packing and delivery to site, erection and commissioning of the PLC Control & Monitoring System comprising PLC Control panel/Remote I/O panel (housing Processors, I/O cards, power supply packs etc.), Operator workstations(OWS), Printers, Annunciation system, UPS, cables and all other equipments and accessories required for completeness of the system as mentioned in different sections of this specification.

2. GENERAL

- 2.1. The PLC shall perform protection logic, interlock and sequential control functions such as binary logic operation, set/reset operation, timers, counters, logic blocks, math functions, input quality checking engineering unit conversion, Boolean functions & PID control (Analog logic function).
- 2.2. The system shall be redundant in processor, power supply and communication interfaces unless otherwise specified. The system shall have self-diagnostic features. The control of all drives and equipment shall be effected through the keyboard/mouse / panel mounted push button / control switches as per Data sheets-A&B.
- 2.3. The system shall have facility for connecting to Main Plant's Distributed control system (DCS) using hardware / software interface for two-way transfer of signals.
- 2.4. The mimic shall be displayed on the OWS screen and may also be provided on the control desk/panel (as per Data sheets).
- 2.5. In case OWS is provided, HMI functions like Trends, Curves, Bar charts, Historical storage of Data, Logs and reports etc. shall be provided in addition to Plant-schematics. The necessary catalogue / literature elaborating the features of HMI shall be supplied along with the bid.
- 2.6. It shall be possible to use the same OWS as programming station.
- 2.7. The PLC system shall be sized to meet process/system requirements as per the approved P&IDs and Control write-up.
- 2.8. The PLC system shall be designed to ensure that no single device failure should result in failure of any other device.
- 2.9. Signal multiplication where required shall be done in PLC. Use of relays for multiplication of contacts (for control, monitoring and alarm) is not acceptable. The control/ monitoring components on the control panel/ desk shall be driven through I/O modules.

3. TECHNICAL REQUIREMENTS

Details of various PLC system components shall be inclusive of but not limited to the following:

3.1. CODES AND STANDARDS

- 3.1.1. The equipment covered under this specification shall meet the requirements of latest edition of all applicable codes and standards like ANSI, NEMA, IEEE, IEC, NEC & IS.

	TITLE: SPECIFICATION FOR PROGRAMMABLE LOGIC CONTROLLER SYSTEM	SPECIFICATION NO. PES-145-36	
		VOLUME II-B	
		SECTION D	
		REV. NO. 02	DATE: July 19, 2008
		SHEET 2	OF 9

3.1.2. PLC shall conform to IEC: 1131

3.1.3. The offered PLC shall **comply with safety standards as per Data sheet-A&B.**

3.2. CONTROL PANEL

3.2.1. PLC control panel shall be freestanding type with provision for mimic display, push-button stations, control switches, indicating lamps, metering instruments like Indicators, ammeters etc. and facia windows for critical alarms.

3.2.2. The salient features of construction shall be:

Sheet material: Cold rolled sheet steel
Frame thickness: Not less than 3.0mm
Enclosure thickness: Not less than 2.0 mm for load bearing sections (mounted with instruments) and Not less than 1.6 mm for others
Gland plate thickness: 3.0mm
Base channel: ISMC 100 with anti-vibration mounting & foundation bolts.

3.2.3. Each panel shall be identified by a name plate, which shall be of non-rusting metal or three ply lamicald, with engraved lettering.

3.2.4. 25 x 6 mm Copper ground bus to be provided for each panel.

3.2.5. 240V AC single phase, thermostatically controlled space heaters shall be provided. Each free standing panel shall have a door switch operated fluorescent lamp and a 240V AC plug point.

3.2.6. Painting treatment shall be as per IS: 6005. Two coats of lead oxide primer shall be followed by powder coating. Paint shade shall be as specified in the "Data sheet for PLC system"-Data Sheet-A&B.

3.2.7. The annunciation system shall be facia window type, driven by the PLC. Audible alarm, Acknowledge, Reset and lamp test facility shall be provided as per ISA sequence – S18.1, M.

	TITLE: SPECIFICATION FOR PROGRAMMABLE LOGIC CONTROLLER SYSTEM	SPECIFICATION NO. PES-145-36	
		VOLUME II-B	
		SECTION D	
		REV. NO. 02	DATE: July 19, 2008
		SHEET 3	OF 9

3.3. PROCESSORS

- 3.3.1. The microprocessors shall be 32 bit, and Hot redundant.
- 3.3.2. Hot redundancy: PLC shall be provided with two processors (Main processing unit and memories) one for normal operation and one as hot standby. In case of failure of working processor, there shall be an appropriate alarm and simultaneously the hot standby processor shall take over the complete operation automatically. This transfer from main processor to standby processor shall be bump less and shall not cause any disturbance whatsoever. In the event of both processors failing, the system shall revert to fail safe mode. It shall be possible to keep any of the processor as master and other as standby.
- 3.3.3. **An authorized forcing facility shall be provided for changing the status of inputs and outputs, timers and flags to facilitate fault finding and other testing requirements.**
- 3.3.4. The standby processor shall be updated automatically in line with the changes made in the working processor.
- 3.3.5. **In the event of any replacement of the processor, synchronization of the replaced processor shall be automatic upon live insertion.**
- 3.3.6. The cycle time for input scanning, execution of logics, overheads and output scan shall not exceed 120 m sec.
- 3.3.7. The processor & memory shall be loaded up to 50% at normal conditions and maximum up to 60% under worst loading conditions.
- 3.3.8. The memories shall be field expandable.

3.4. INPUT / OUTPUT Modules

- 3.4.1. Input/output card assignments shall be modular i.e. no single card shall be assigned with more than one drive of a particular sub-system. The maximum number of channels per I/O module shall be as follows.
- Analog Input Module: 16
 - Analog Output Module: 16
 - Binary Input Module: 32
 - Binary Output Module: 32
 - Analog Input/output combined: 16
 - Binary Input/output combined: 32
- 3.4.2. On line I/O replacement: All I/O cards shall have quick disconnect terminations allowing for card replacement without disconnection of external wiring and without switching off the power supply.
- 3.4.3. 10% spare capacity shall be ensured in each card channel assignment. Overall minimum 20% spare channels shall be provided.

	TITLE: SPECIFICATION FOR PROGRAMMABLE LOGIC CONTROLLER SYSTEM	SPECIFICATION NO. PES-145-36	
		VOLUME II-B	
		SECTION D	
		REV. NO. 02	DATE: July 19, 2008
		SHEET 4	OF 9

3.4.4. Output command to MCC/Switchgear shall be through coupling relays, whose mounting location shall be as per "Data sheet A & B for PLC System". In case coupling relays are located in PLC Panel, the same shall be in PLC vendor's scope of supply.

3.4.5. Status feedback from MCC shall be in the form of potential free contact.

3.5. DATA BUS/ I/O BUS

3.5.1. The Data bus connecting PLC and HMI work stations shall be TCP/IP on Ethernet.

3.5.2. The Data bus and I/O bus communication medium shall be twisted pair shield copper conductor for indoor locations and those areas not subjected to induced signals. Repeaters/signal amplifiers shall not be used. Copper conductor cable used shall be Category-5 or better. The communication medium shall be Fibre optic cable in the event any portion of communication cable run is in outdoor or where distances are beyond 500 meters.

3.6. OPERATOR WORK STATION (OWS)

3.6.1. The OWS and Keyboard shall be desktop mounted and shall be used for controlling, monitoring and programming function.

3.6.2. Colour CRT(s) with keyboard and mouse shall be as per Data Sheet-A&B. CRT shall have graphic display facility.

3.6.3. The OWS shall be with Windows based operating system having necessary Engineering/Configuring software.

3.7. PRINTER

Printers shall be provided as per Data Sheet-A&B.

	TITLE: SPECIFICATION FOR PROGRAMMABLE LOGIC CONTROLLER SYSTEM	SPECIFICATION NO. PES-145-36	
		VOLUME II-B	
		SECTION D	
		REV. NO. 02	DATE: July 19, 2008
		SHEET 5	OF 9

3.8. COMMUNICATION WITH PLANT DCS

- 3.8.1. The PLC system shall be provided with hardwired/serial interface for communication with plant DCS.
- 3.8.2. Serial communication to / from DCS where provided shall be engineered to ensure that signal communication time from / to DCS shall not exceed 1 seconds for control / feedback.
- 3.8.3. Serial communication to DCS shall be OPC (Data access 2.0), Ethernet based TCP/IP Protocol. Alternatively the serial communication shall be MODBUS protocol on RS 485 network.
- 3.8.4. Data transmitted from PLC to DCS shall include all information necessary for the DCS graphic displays to monitor and control the process equipment and PLC. Such data may include pertinent analog and digital status information, interlock, alarms and maintenance conditions. Data transmitted from DCS to the PLC shall include necessary signals to provide operator control interface from DCS for the process/ equipment being controlled by PLC.
- 3.8.5. Bidder to include 'Light interface units, converters, Ethernet switch, accessories at PLC end for connectivity to other system. The bidder's terminal point shall be Ethernet port in case of copper medium connection to DCS or LIU in case of Fiber optic medium for connectivity with plant DCS. In case distance between PLC & DCS is greater than 1.8 Km, single mode of optical fiber cable with compatible accessories shall be used. For distance less than 1.8 Km multimode optical fiber ports shall be used.

3.9. POWER SUPPLY Scheme

- 3.9.1. PLC Panel and I/O Cabinets: PLC system shall be provided with 2x100% UPS fed from Two Nos. redundant 415V, 3-ph feeders, as per the scheme PE-SD-999-145-001, sh-08 of 08. Each UPS shall have 30 minutes back up. Input feeder failure shall be monitored in the PLC system. Necessary redundant power pack and transformers shall be provided (in the PLC panel) to derive the power supply for control desk, PLC panel and input / output cabinets etc
- 3.9.2. Remote I/O panels: Similar power supply arrangement as for PLC panels shall be provided if it is not possible to extend the power cable form UPS of PLC panels.
- 3.9.3. Each OWS and associated HMI peripherals shall be provided with a feeder from either one of the UPS

4. DRAWING/DOCUMENT AND DATA TO BE FURNISHED AFTER AWARD OF THE CONTRACT:

4.1. For Approval:

- PLC system configuration drawing along with functional write-up.
- Input/Output signal list.
- BOM of PLC
- List of PLC controlled devices
- Control panel/control desk GA drawings.
- Control desk/panel component layout drawing.
- Control panel/control desk Foundation detail and cutout drawings
- Power distribution scheme.

	TITLE: SPECIFICATION FOR PROGRAMMABLE LOGIC CONTROLLER SYSTEM	SPECIFICATION NO. PES-145-36	
		VOLUME II-B	
		SECTION D	
		REV. NO. 02	DATE: July 19, 2008
		SHEET 6	OF 9

- Block logic diagrams.
- Annunciation list.
- PLC control room layout drawing.
- List of soft signal exchange with Plant DCS.
- List of mandatory spares
- Quality plan
- Data Sheet-C
- CRT display
- Power supply scheme for PLC system, HMI & peripherals, Remote I/O etc.

4.2. For Information:

- Cable schedule and cable interconnection drawing(in BHEL approved format)
 - Between Field and PLC
 - Between Field and MCC
 - Between MCC and PLC
- Electronic earthing requirements.
- Panel Heat dissipation data
- Product/component catalogues.
- Operation & Maintenance Manual on CDs.
- Softcopy of Final/As-built drawings on CDs.
- Calculation for Processor, Memory & Data bus loading

The above list is the minimum requirements. Additional documents/calculations required shall be finalized during contract stage.

5. DRAWINGS AND DOCUMENTS TO BE SUBMITTED ALONG WITH THE BID

- Proposed PLC system configuration drawing with write-up
- Product catalogues and specifications for PLC as well as HMI application.
- Proposed power supply schemes for PLC system, peripherals, and Remote I/O panels.

6. TESTING AND INSPECTION

- 6.1. The bidder shall adopt suitable quality assurance program to ensure that the equipments offered will meet the specification requirements in full.
- 6.2. BHEL's standard Quality Plan for PLC is enclosed with the specification. The bidder shall furnish his acceptance to BHEL's QP and submit the signed and stamped copy of QP along with the offer.
- 6.3. The complete PLC system, including all instrument and devices shall be subjected to standard factory tests (i.e. Type Tests and Routine Tests) as per relevant IS, NEMA, IEEE, IEC.
- 6.4. Factory Acceptance Test-FAT (Functional Tests) shall be performed prior to shipment and Owner/Purchaser shall be notified 15 days before the schedules dates of the test.
- 6.5. The certificates for following type tests, as per IEC Standard, shall be submitted: -
 - Surge protection test as per IEC-225-4
 - Dry heat test as per IEC-68-2-2
 - Damp Heat test as per IEC-68-2-3

	TITLE: SPECIFICATION FOR PROGRAMMABLE LOGIC CONTROLLER SYSTEM	SPECIFICATION NO. PES-145-36	
		VOLUME II-B	
		SECTION D	
		REV. NO. 02	DATE: July 19, 2008
		SHEET 7	OF 9

- Vibration Heat test as per IEC-68-2-6
- Electrostatic discharge test as per IEC-801-2 or equivalent
- Radio frequency Immunity test as per IEC-801-6 or equivalent
- Electromagnetic Immunity test as per IEC-801-3 or equivalent

7. SPARES AND CONSUMABLES

7.1. Commissioning Spares and consumables

The bidder shall supply all commissioning spares and consumables 'as required' during Start-up, as part of the main equipment supply.

7.2. Mandatory Spares

The bidder shall offer alongwith main offer, the Mandatory Spares as specified elsewhere in the specification. The Mandatory Spares offered shall be of the same make and type as the main equipment.

7.3. Recommended Spares

The bidder shall furnish a list of Recommended Spares indicating the normal service expectancy period and frequency of replacement; quantities recommended for 3 years operation alongwith unit rate against each item to enable BHEL/BHEL's Customer to place a separate order later, if required.

7.4. Special Tools & Tackles

The bidder shall supply all Special Tools & Tackles 'as required' during Start-up and further maintenance of the system, as part of the main equipment supply.

7.5. Spares, Service support

Bidder shall provide availability of spares and service support for minimum 10 years after guarantee period.

8. MARKING AND PACKING

8.1. Marking:

A stainless steel name-plate shall be permanently fixed on each equipment giving its Tag/serial Number and salient technical specification.

8.2. Packing:

All equipment/materials shall be suitably packed and protected for the entire period of dispatch, storage and erection against impact, abrasion, corrosion, incidental damage due to vermin, sunlight, high temperature, rain, moisture, humidity, dust, sea-water spray (where applicable) as well as rough handling and delays in transit and storage in open.

9. PERFORMANCE AND GUARANTEE

Form No. PEM-6666-0

	TITLE: SPECIFICATION FOR PROGRAMMABLE LOGIC CONTROLLER SYSTEM	SPECIFICATION NO. PES-145-36	
		VOLUME II-B	
		SECTION D	
		REV. NO. 02	DATE: July 19, 2008
		SHEET 8	OF 9

The PLC system shall be guaranteed to meet the performance requirement as specified and also for trouble-free continuous operation for 12 months from the date of commissioning or 18 months from the date of delivery at site whichever is later unless specified otherwise in Vol-IIB Section - B or Section - C.

10. APPLICABLE DATA SHEET FORMS

This document shall be read with the following data sheet forms :

- Data Sheet A & B for PLC system - PE-DC-999-145-I036-1
- Data Sheet C for PLC system - PE-DC-999-145-I036-2

11. Bidder shall provide at least 20% wired spare capacity of I/O modules over and above system requirement.

12. Bidder shall include 10% or 1 No. (whichever is higher) each type of module, which shall include controller card, communication card, I/O card, Power supply card/ unit, relays, push button, lamps etc.

PLC INTERFACE FOR BIDIRECTIONAL DRIVE

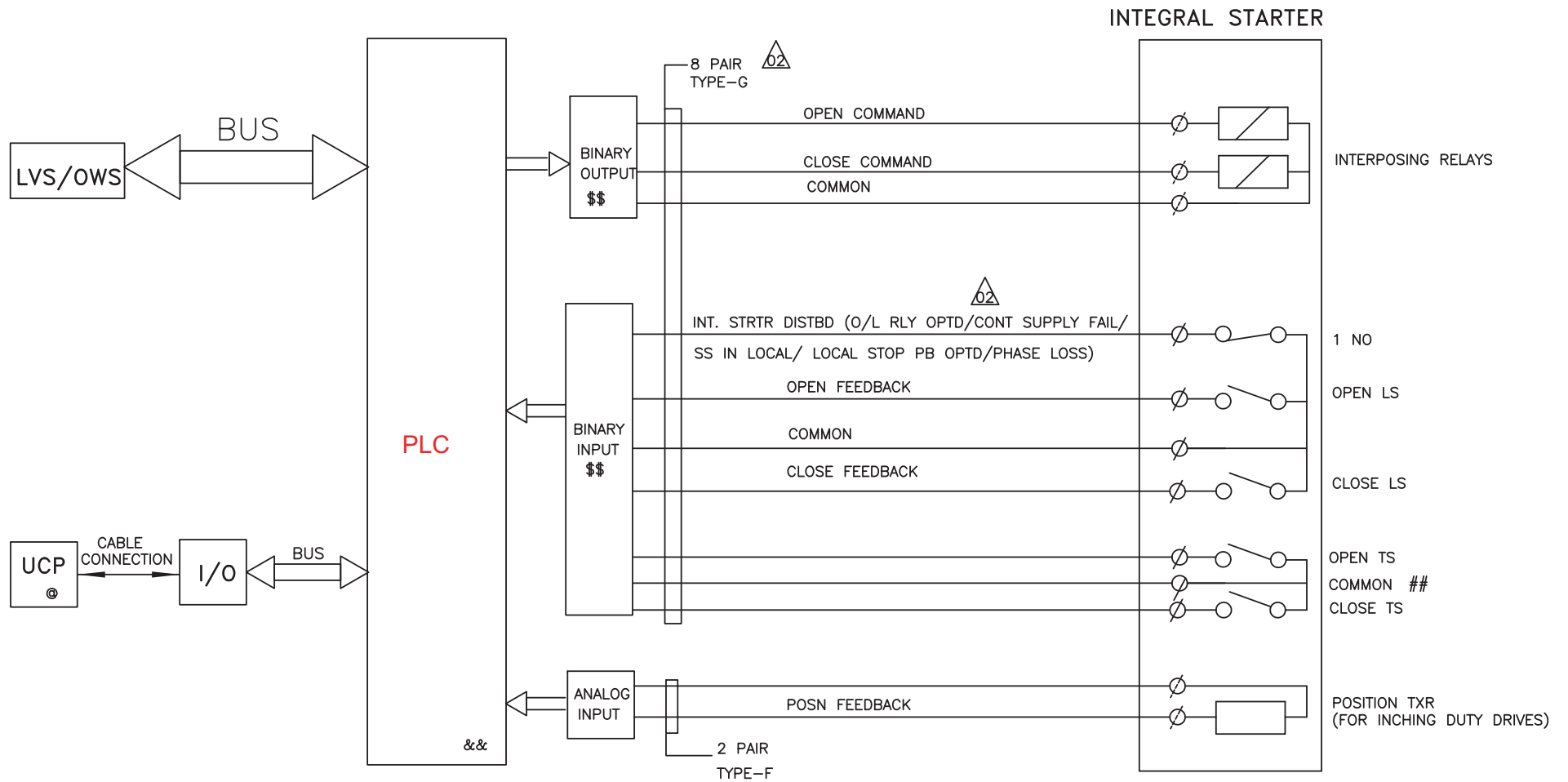

NOTE:

1. TYPE-G : OVERALL SCREENED TWISTED PAIR CABLE (0.5 sq mm)
2. 'TYPE-F' INDIVIDUAL & OVERALL SCREENED TWISTED PAIR CABLE (0.5 sq mm)
3. '\$\$\$' REDUNDANT INPUTS/ OUTPUTS FOR CRITICAL SERVICES..
4. '&&' REDUNDANT PROCESSOR .
5. © REFER CL. NO. 1.0(C).
6. ## FOR IMPORTANT DRIVES, AS INDICATED IN DRIVE LIST.

	KARNATAKA POWER CORPORATION LIMITED BELLARY THERMAL POWER STATION STAGE - III (1 x 700MW)		DRG NO.	PE-DM-367-145-1002
	PLC INTERFACE FOR BIDIRECTIONAL DRIVE		DATE	25.11.2011
			REV. NO.	02
			SH. 8	OF 13 SHS

PLC INTERFACE FOR UNIDIRECTIONAL LT DRIVE

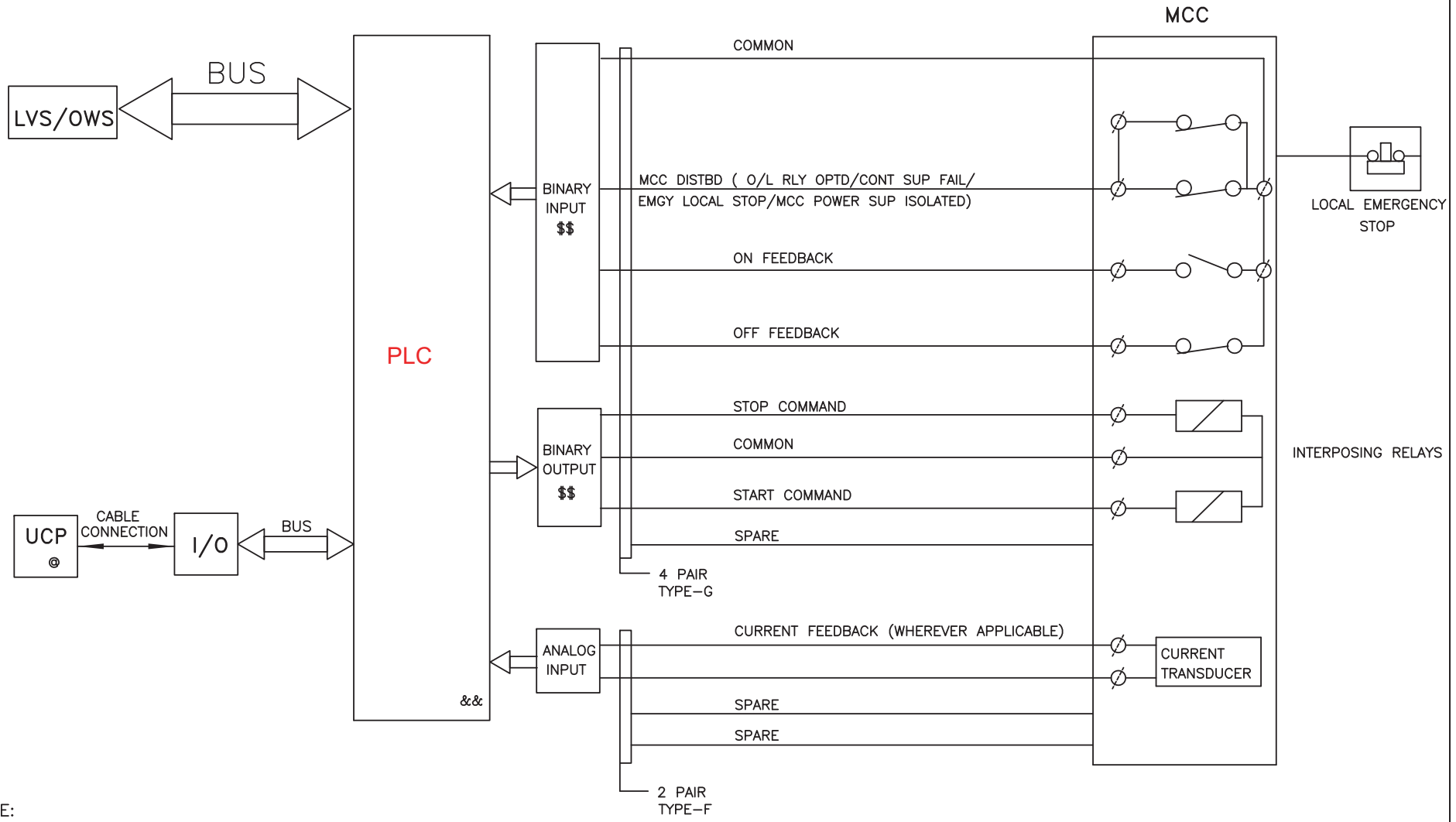

- NOTE:
1. TYPE-G : OVERALL SCREENED TWISTED PAIR CABLE (0.5 sq mm)
 2. TYPE-F INDIVIDUAL & OVERALL SCREENED TWISTED PAIR CABLE (0.5 sq mm)
 3. '\$\$\$' REDUNDANT INPUTS/ OUTPUTS FOR CRITICAL SERVICES .
 4. '&&' REDUNDANT PROCESSOR .
 5. © REFER CL. NO. 2.0(b).

	KARNATAKA POWER CORPORATION LIMITED		DRG NO.	PE-DM-367-145-1002
	BELLARY THERMAL POWER STATION		DATE	25.11.2011
	STAGE - III (1 x 700MW)		REV. NO.	02
	PLC INTERFACE FOR UNIDIRECTIONAL LT DRIVE		SH.	9 OF 13 SHS

PLC INTERFACE FOR UNIDIRECTIONAL HT DRIVE HT SWGR

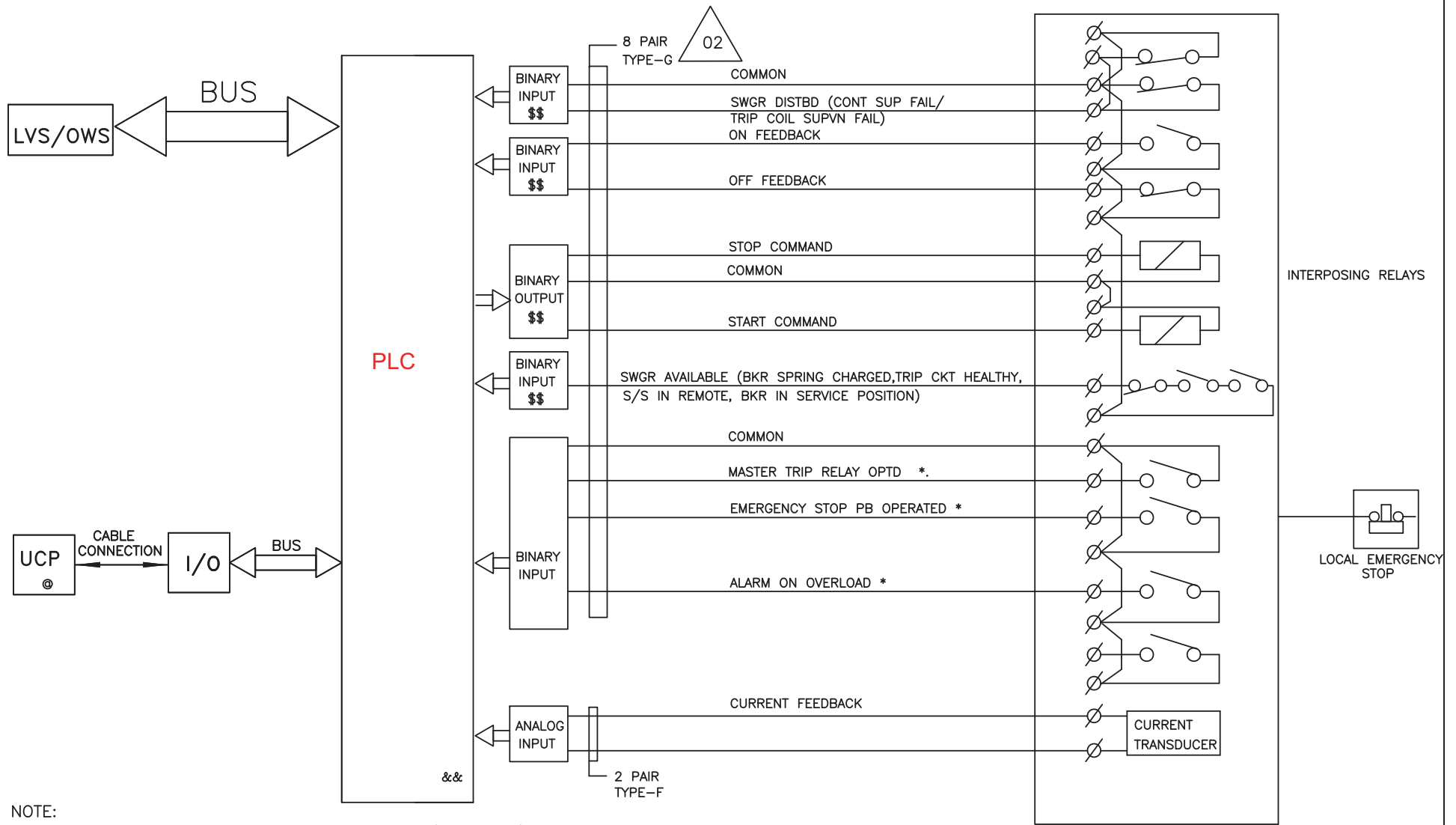

NOTE:

1. TYPE-G : OVERALL SCREENED TWISTED PAIR CABLE (0.5 sq mm)
2. TYPE-F INDIVIDUAL & OVERALL SCREENED TWISTED PAIR CABLE (0.5 sq mm)
3. '\$\$\$' REDUNDANT INPUT/OUTPUT FOR CRITICAL SERVICES.
4. ** REFER CLAUSE 5.0
5. '&&' REDUNDANT PROCESSOR
6. '*' FOR ANNUNCIATION
7. © REFER CL.NO 4.0(C).



KARNATAKA POWER CORPORATION LIMITED
BELLARY THERMAL POWER STATION
STAGE - III (1 x 700MW)
PLC 5 INTERFACE FOR UNIDIRECTIONAL HT DRIVE

DRG NO.	PE-DM-367-145-1002
DATE	25.11.2011
REV. NO.	02
SH. 12	OF 13 SHS

SINGLE LINE DIAGRAM OF UPS

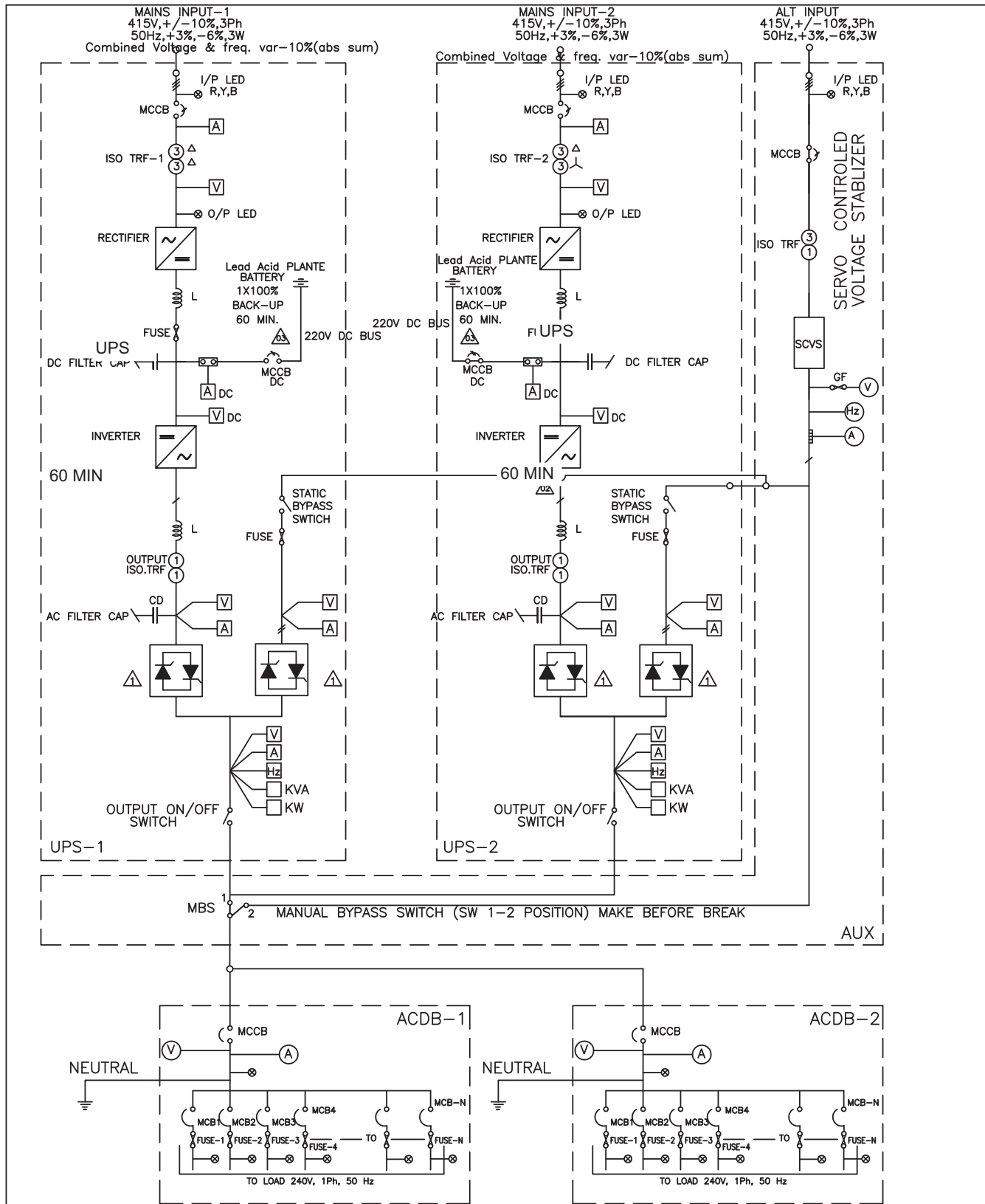

NOTES:

1. ACDB-1&2 NEUTRAL TO BE GROUNDED TO A DEDICATED GROUND.
2. ALL OUTPUT FEEDERS OF ACDB SHALL BE PROVIDED WITH AN LED FOR FEEDER ON INDICATION WITH FEEDER DESCRIPTION.
3. REDUNDANT FEEDERS SHALL BE LOCATED IN DIFFERENT ACDBs.
4. FOR FURTHER DETAILS REFER TECHNICAL SPECIFICATION SECTION D2.25 VOL IV SHT 233-246

DRG PE-DG-367-145-1004
REV 03
SHEET 2 OF 2



TITLE:

**TECHNICAL SPECIFICATION FOR
OZONE GENERATION PLANT**

**1X700 MW BELLARY THERMAL POWER
STATION UNIT NO. 3, STAGE-3**

BHEL DOCUMENTS NO.: PE-TS-367-174-14000A-A001

VOLUME II-B

SECTION -D3

REV. NO. 02

DATE: 04/12/2014

GENERAL TECHNICAL REQUIREMENTS FOR LOCAL CONTROL PANEL

BHEL – PS - PPEI: NOIDA, SECTOR-16A, U.P. – 201301

FORM NO. PEM-6666-0

	DATA SHEET FOR LOCAL CONTROL PANEL		SPECIFICATION NO.: PE-TS-999-145-1990		
			VOLUME		
			SECTION		
	REV. NO.	00	DATE:		
		SHEET	1	OF	1
TAG No. Qty.....					
Data Sheet A & B					
DATA SHEET-A FOR LOCAL PANEL (TO BE FILLED BY PURCHASER)			DATA SHEET-B (TO BE FILLED-UP BY BIDDER)		
GENERAL	MANUFACTURER				
	CONSTRUCTION		<input checked="" type="checkbox"/> FOLDED <input type="checkbox"/> WELDED (As per requirement)		
	ENCLOSURE SHEET THICKNESS	FRONT	<input checked="" type="checkbox"/> 3.0 mm		
		OTHER	<input checked="" type="checkbox"/> 3.0 mm		
DOOR		<input checked="" type="checkbox"/> 3.0 mm			
TECHNICAL	INPUT POWER SUPPLY		<input type="checkbox"/> 240V 50 Hz AC <input type="checkbox"/> 220V DC <input checked="" type="checkbox"/> 415V 3 PHASE <input type="checkbox"/>		
	NO. OF FEEDERS		<input type="checkbox"/> ONE <input checked="" type="checkbox"/> TWO		
	CONTROL SUPPLY		<input type="checkbox"/> 110V AC <input checked="" type="checkbox"/> 220V AC <input type="checkbox"/> 220V DC <input type="checkbox"/> During detailed engg. (As per requirement)		
	ALARM ANNUNCIATOR WINDOW (EXCLUDING SPARES)		_____NOS. (AS REQUIRED)		
	PAINT TYPE		<input type="checkbox"/> EPOXY ENAMEL <input checked="" type="checkbox"/> EPOXY POWDER COATED		
	PANEL COLOUR (EXTERNAL)		<input checked="" type="checkbox"/> LIGHT GREY (Shade 631 IS-5) (Project specific) <input type="checkbox"/> OPALINE GREEN (Shade 275) <input type="checkbox"/> During detailed engg.		
	FINISH		<input checked="" type="checkbox"/> MATT <input type="checkbox"/> GLOSSY <input type="checkbox"/> SEMI GLOSSY		
	PANEL COLOUR (INTERNAL)		<input checked="" type="checkbox"/> WHITE <input type="checkbox"/> CREAM <input type="checkbox"/> OFF WHITE		
	FINISH		<input type="checkbox"/> MATT <input type="checkbox"/> GLOSSY <input checked="" type="checkbox"/> SEMI GLOSSY		
	CLASS OF PROTECTION		<input checked="" type="checkbox"/> IP-65 <input type="checkbox"/> IP-55		
	CONTROL HARDWARE		PLC BASED		
	FOUNDATION ARRANGEMENT		<input checked="" type="checkbox"/> FOUNDATION BOLTS <input type="checkbox"/> ANCHOR FASTENERS		
	WEIGHT OF PANEL (Kg.)				
	PANEL TYPE		<input type="checkbox"/> PRESSURISED <input checked="" type="checkbox"/> UNPRESSURISED As per Requirement		
	CABLE GLAND		<input type="checkbox"/> SINGLE COMPRESSION <input checked="" type="checkbox"/> DOUBLE COMPRESSION		
	AMMETER (TYPE OF INPUT)		<input type="checkbox"/> 1 Amp CT <input type="checkbox"/> 4-20 mA		
NAME SIGNATURE DATE	PREPARED BY	CHECKED BY	APPROVED BY	COMPANY SEAL NAME SIGNATURE DATE	

FORM NO. PEM-6866-0

	DATA SHEET FOR LOCAL PANELS			SPECIFICATION NO.:	
				VOLUME	
				SECTION	
				REV. NO.	DATE:
				SHEET 1	OF 1
TAG No. Qty.....					
Data Sheet C					
DATA SHEET-C FOR LOCAL PANEL (TO BE FILLED BY CONTRACTOR AFTER AWARD OF CONTRACT)					
GENERAL	MANUFACTURER				
	CONSTRUCTION				
	ENCLOSURE SHEET THICKNESS	FRONT			
		OTHER			
DOOR					
TECHNICAL	INPUT POWER SUPPLY				
	NO. OF FEEDERS				
	CONTROL SUPPLY				
	ALARM ANNUNCIATOR WINDOW (EXCLUDING SPARES)				
	PAINT TYPE				
	PANEL COLOUR (EXTERNAL)				
	FINISH				
	PANEL COLOUR (INTERNAL)				
	FINISH				
	CLASS OF PROTECTION				
	CONTROL HARDWARE				
	FOUNDATION ARRANGEMENT				
	WEIGHT OF PANEL (Kg.)				
	PANEL TYPE				
	CABLE GLAND				
	AAMETER (TYPE OF INPUT)				
NAME SIGNATURE DATE	PREPARED BY	CHECKED BY	APPROVED BY	COMPANY SEAL NAME SIGNATURE DATE	

	SPECIFICATION FOR LOCAL PANELS	SPECIFICATION NO.: PES – 145 – 054A		
		VOLUME	II B	
		SECTION	D	
		REV. NO.	02	DATE : 22-02-2008
		SHEET	1	OF 5

1.0 SCOPE
This specification covers the Design, Manufacture, Inspection and Testing at the manufacturer's works, proper packing for transportation and delivery to site of Local Panels required for control and monitoring of the Auxiliary Plant & Equipment.

2.0 CODES AND STANDARDS

2.1 All the equipments specified herein shall comply with the requirements of the latest issue of the relevant National and International standards.

2.2 As a minimum requirement, the following standards shall be complied with:

a)	IS-6005 : 1970	:	Code of practice for phosphating of iron and steel.
b)	IS-5 : 1978	:	Colours for ready mixed paints and enamels.
c)	IS-1248:1983	:	Direct Acting Indicating Instruments.
d)	IS-13947 (Part-III):1993	:	Rotary Cam Switches.
e)	IS-6875:1973	:	Auxiliary relays.
f)	IS-8828:1993	:	Circuit breaker for household and similar installations.
g)	IS-13947 (Part-I):1993	:	Low Voltage switchgear & control gear : Part-I (General Rules)
h)	NFPA-496:1974	:	Purged & Pressurised Enclosure for Electrical Equipment in Hazardous Locations.

3.0 TECHNICAL REQUIREMENTS

3.1 Panel Construction

3.1.1 The local panels shall house the secondary instruments, annunciation system, Single loop controller, Control switches / push buttons, indicating lamps, relays, timers and other devices required for operation and monitoring of the equipment locally.

3.1.2 The panels shall be of free standing type either welded construction on angle iron (minimum section of 50 x 50 x 4 mm) structure or folded construction by sheet metal formation depending upon the equipments to be mounted on it. The panels shall be robustly built and stiffeners as necessary shall be provided.

3.1.3 The panel shall be suitably reinforced to ensure adequate support for all instruments mounted thereon. All welds on exposed panel surfaces shall be ground smooth.

3.1.4 **The salient features of construction shall be:**

Sheet material: Cold rolled sheet steel
 Frame thickness: Not less than 3.0mm
 Enclosure thickness: Not less than 2.5 mm for load bearing sections (Mounted with instruments),
 1.6 mm for doors and Not less than 2.0 mm for others
 Panel Height: Not less than 2365 mm
 Gland plate thickness: 3.0mm
 Base channel: ISMC 100 with anti-vibration mounting & foundation bolts.

3.1.5 The panel shall be provided with rear doors with integral lockable handle. The door when locked shall be held at minimum three places. The door width shall not be more than 550mm. The doors shall be provided with suitable stiffeners to prevent buckling. The handle shall be on the right side of the door. The door shall be removable type with concealed hinges to facilitate maintenance work. Suitable pocket inside the door shall be provided for keeping the drawings / documents.

3.1.6 Suitable neoprene gasket shall be provided on all doors and removable covers. Suitable ventilation louvers shall be provided at bottom and top of the doors covered with removable wire mesh.

FORM NO. PEM-666-0

	SPECIFICATION FOR LOCAL PANELS	SPECIFICATION NO.: PES – 145 – 054A		
		VOLUME	II B	
		SECTION	D	
		REV. NO.	02	DATE : 22-02-2008
		SHEET	2	OF 5
<p>3.1.7 The class of protection shall be in accordance with IP-42 unless otherwise specified in the data sheet – A (No. PES-145-54A-DS1-0).</p> <p>3.1.8 All steel surfaces shall be cleaned by sand / pellet blasting, treated for pickling, degreasing and phosphating etc. by seven tank method. The panel shall have a high quality finish and appearance. The panel shall be painted with two coats of primer followed by two coats of epoxy / synthetic enamel based final paint of color shade and finish as given in data sheet-A (No. PES-145-54A-DS1-0). Minimum thickness of the paint shall be 85 microns for external paint and 70 microns for internal paint.</p> <p>3.1.9 The cable glands of the required size and type as given in data sheet-A (No. PES-145-54A-DS1-0) shall be supplied alongwith the Panel.</p> <p>3.1.10 All operable and indicating devices shall be mounted on the front of the panel while aux. Relays / timers MCBs etc. required for realization of control logics shall be mounted on a mounting plate inside the panel. Auxiliary relays and timers etc. shall be grouped according to the control function. No operable or indicating devices shall be mounted below 750 mm and above 1800 mm (w.r.t. finished ground level). The devices shall be located in such a way so as to ensure easy access for operation / maintenance.</p> <p>3.1.11 Single / dual control power supply feeders of voltage class as specified in data sheet-A (No. PES-145-54A-DS1-0) shall be provided by the purchaser. In case redundant power supply feeders are provided then auto changeover unit shall be mounted on the panel are in the panel supplier's scope. Where DC control power supply is specified an additional 240V, 50 Hz AC supply feeder for powering of space heater and lighting shall be provided by the purchaser. Suitable arrangement shall be provided inside the panel to receive and terminate the power supply feeder(s). For this purpose MCBs of suitable current rating shall be provided by the vendor. A supervisory relay along with a pilot lamp to indicate control supply 'ON' shall be provided on the panel. Any other power supply required for the operation of the devices mounted in the panel shall be arranged by the vendor.</p> <p>3.1.12 The internal wiring shall be carried out with 1100 volt grade PVC insulated copper multi strand wire / flexible of 1.5mm² size. AC & DC wires shall be kept separate from each other. Separate coloured wires to be used for AC and DC circuits. All wires shall be properly numbered and identified with ferrules as per the Control scheme / wiring diagram. Wires shall be routed and run through PVC troughs.</p> <p>3.1.13 Terminal blocks shall be clip on type, 1100 volts grade. Separate terminal blocks shall be used for AC & DC circuits. The terminals shall be suitable for terminating 0.5 mm² to 2.5mm² external cables. The terminal for ammeters shall be provided with removable links for shorting CTs. Each terminal strip shall be provided with identification strip. The terminal shall not be mounted below 250 mm height from finished floor. The panel shall have ten (10) percent spare terminal.</p> <p>3.1.14 The interior of each panel shall be suitably illuminated through fluorescent lamps operable on 240V 50 Hz AC power supply through panel door switch. A 15 Amp. 3-pin Power receptacle shall be provided.</p> <p>3.1.15 Suitable space heaters operable on 240 Volts 50 Hz AC power system shall be provided at the panel bottom. These shall be designed to maintain the panel temperature five (5) deg. C above the ambient temperature during maintenance shutdown. Suitable isolating and control devices comprising of MCB, thermostat etc. shall be provided for the space heater.</p> <p>3.1.16 The panel shall be provided with a copper earth bus of 25 x 6 mm size running throughout the width of the panel. It shall be terminated internally with 10 mm bolts at extreme ends for connection to; main station earth. The panel mounted equipments / devices shall be connected to earth bus through green coloured PVC insulated stranded copper conductor of 2.5 mm² size.</p> <p>3.1.17 Local Panel shall be provided with main name plate of 150 mm x 40 mm size having inscription of 20 mm height. The individual devices on the panels shall be as provided with separate name plate with inscription of 3 mm height. The instrument / devices shall be provided with stick on label plates inside the panel. The material of the main and individual labels shall be three (3) ply 3 mm thick Traffolyte Sheet / 2 mm Anodised Aluminium Plate. The inscription shall be with white letters on black background on traffolyte sheet. The labels shall be fixed by self tapping non-rusting screws.</p>				

FORM NO. PEM-666-0

	SPECIFICATION FOR LOCAL PANELS	SPECIFICATION NO.: PES – 145 – 054A		
		VOLUME	II B	
		SECTION	D	
		REV. NO.	02	DATE : 22-02-2008
		SHEET	3	OF 5

3.2 Hazardous Area Panel Requirement

3.2.1 The Local Panel located in hazardous area shall be pressurized as per NFPA-496 requirements to render it non-hazardous. Alarms shall be provided for local and remote annunciation when pressurisation falls below 2.5 mm of water column. Protection shall be of type Z of NFPA-496. It shall not be possible to switch ON the power of purged section unless it is purged as per the recommendation of NFPA-496. Vendor must provide a protective device on the panel to protect the panel from over pressurisation.

3.2.2 Vendor shall supply pressurisation kit consisting of valves, restriction orifices, dual filter regulation, pressure gauges, pressure switches, rotameter etc. Pressurisation kit shall be surface mounting on a metal board and located outside the local panel. Pressurisation kit shall further consist of solenoid valve flow switch, timer blow off safety device etc., so as to make purging fully automatic. However final start shall be manual. Panel protection against over pressure to be provided as per NFPA-496.

3.2.3 Pressurised local control panel pressurization kit assembly design shall provide minimum leakage flow through the Local Control Panel. Panel venting shall be as per NFPA-496.

3.2.4 All components in the local panel like indicating instruments, push buttons switches, lamps etc., which are required to be energized without panel pressurization or before completion of purge cycle shall be explosion proof as per NEMA-7 & suitable for area classification.

3.2.5 All push buttons etc. requiring frequent operation during machine running shall have good positive sealing. Weatherproof housing or cover to be provided wherever necessary. Vendor shall provide pressurisation bypass switch outside explosion proof enclosure of pressurized panel with lamp indication. This shall be used only during maintenance. All hinges, screws, other non-painted metallic parts shall be of stainless steel material.

3.2.6 Provision to switch off manually all types of power shall be provided in the panel. In addition, it shall also be possible to switch off power circuits / components which are powered from motor control centre or control room manually in case of pressurization failure. All such cables from MCC and main control room shall be terminated in explosion proof boxes (NEMA-7).

3.3 Control & Monitoring devices

3.3.1 Instruments like Indicators, recorders, single loop controllers etc. as applicable and specified elsewhere for the plant / equipment shall be supplied and mounted on the panel.

3.3.2 Alarm Annunciator System
It shall be solid state discrete facia type having a sequence of ISA-S18.1A or as specified, opaque facia windows of 70 mm x 50 mm size, having two (2) lamps per window, and hooter of 10W, and provision for repeat group alarm at remote. The annunciator shall be provided with ten (10) percent spare windows or minimum two (2) windows along with electronics.

3.3.3 Relays
The relays shall be electromagnetic type suitable for specified control supply. Its contact configuration and rating shall be suitable for the specified control function. However minimum contact rating shall be 5 Amp AC & 2 Amp DC as applicable. There shall be ten (10) percent spare contacts.

3.3.4 Timers
The timers shall be electronic type suitable for specified control supply. Its contact configuration and rating shall be suitable for the specified control function. However, minimum contact rating shall be 5 Amp AC & 2 Amp DC as applicable.

3.3.5 Control / Selector Switches
Switches shall be Rotary Cam type with minimum of 5 Amps AC & 2 Amp DC continuous current rating. Selector switches shall be stay put type while control switches shall be spring-return-to-neutral type. Contact configuration and rating shall be as per the control function requirement. The switches shall be lockable type wherever specified. Each switch shall be provided with engraved plates indicating the switch position / functions.

	SPECIFICATION FOR LOCAL PANELS	SPECIFICATION NO.: PES – 145 – 054A		
		VOLUME	II B	
		SECTION	D	
		REV. NO.	02	DATE : 22-02-2008
		SHEET	4	OF 5

3.3.6 Push Buttons / Indicating Lights

The push buttons shall be momentary action self-resetting type, however stop P.B. for unidirectional drives shall be provided with manual reset facility. Its contact configuration & rating shall be as required for the control function but minimum 2 NO + 2 NC of 5 Amp. AC rating. It shall have round coloured projecting tab and engraved escutcheon plate / inscription plate. Colour coding of push buttons shall be as under:

RED	Motor OFF / Valve CLOSE	YELLOW	Alarm acknowledge.
GREEN	Motor ON / Valve OPEN	BLACK	Lamp test

Indicating lights shall be suitable for direct connections across specified power supplies. It shall be fitted with built in resistance to prevent circuit tripping on shorting of lamp filament. It shall be fitted with LED cluster type lamp replaceable from front.

GREEN	Motor OFF / Valve CLOSED condition	AMBER	Motor tripped condition.
RED	Motor ON / Valve OPEN condition	WHITE	Normal / healthy condition

3.3.7 Ammeters

Ammeter shall be 96 x 96 mm size, 90 deg. deflection, 1.5% accuracy, 1 Amp. CT operated or with 4-20mA input and Flush mounting type as called for in the data sheet-A (No. PES-145-54A-DS1-0). Ammeters for motors shall have six (6) times folded scale at upper end to enable motor starting current indication.

3.3.8 Miniature Circuit Breaker (MCB)

These shall be instantaneous magnetic trip type for short circuit in addition to current time inverse delayed thermal trip feature for over current protection. The housing of MCB shall be made of non-ignitable, high impact material. It shall have minimum short circuit rating of 9 KA for AC Voltages and 4 KA for DC Voltages.

3.3.9 Makes of various instruments / devices shall be as given below

1.	Alarm Annunciators	:	Procon / IIC
2.	Ammeters	:	AEP / IMP
3.	Control / Selector Switches	:	Alsthom / Kaycee / Siemens / L&T
4.	Push Buttons / Indicating Lamps	:	Siemens / L&T / Teknic / Alsthom
5.	Auxiliary Relays	:	Jyoti / Siemens / L&T / OEN
6.	Timers	:	L&T / Alsthom / Bhartiya Cutler Hammer
7.	MCBs	:	S&S Power Engg. / Indo Asian / MDS
8.	Terminal Blocks	:	Jyoti / Elmex

4.0 TESTING AND INSPECTION

4.1 The bidder shall adopt suitable quality assurance program to ensure that the equipments offered will meet the specification requirements in full.

4.2 BHEL's standard Quality Plan for LCP is enclosed with the specification. The bidder shall furnish his acceptance to BHEL's QP and submit the signed and stamped copy of QP along with the offer.

4.3 The vendor shall conduct the following tests as a minimum requirement:

4.3.1 Routine Tests

1. High Voltage (H.V.)
2. Insulation Resistance (I.R.)
3. Functional

4.3.2 Type Tests

1. Enclosure Class Test

	SPECIFICATION FOR LOCAL PANELS	SPECIFICATION NO.: PES – 145 – 054A		
		VOLUME	II B	
		SECTION	D	
		REV. NO.	02	DATE : 22-02-2008
		SHEET	5	OF 5

5.0 SPARES AND CONSUMABLES

5.1 Commissioning Spares and consumables

The bidder shall supply all commissioning spares and consumables ‘as required’ during Start-up, as part of the main equipment supply.

5.2. Mandatory Spares

The bidder shall offer alongwith main offer, the Mandatory Spares as specified elsewhere in the specification. The Mandatory Spares offered shall be of the same make and type as the main equipment.

5.3. Recommended Spares

The bidder shall furnish a list of Recommended Spares indicating the normal service expectancy period and frequency of replacement; quantities recommended for 3 years operation alongwith unit rate against each item to enable BHEL/BHEL’s Customer to place a separate order later, if required.

6.0 DRAWINGS AND DOCUMENTS

6.1 The bidder shall furnish the following documents in required number of copies along with the bid :

1. Data Sheet no. PES-145-54A-DS1-0
2. General Arrangement Drawing.
3. Catalogue and technical information for instruments and devices.
4. Quality Plan.

6.2 The vendor shall furnish the following documents in required number as agreed after the award of contract:

1. Data Shee No. PES-145-54A-DS2-0
2. GA Drawing indicating layout of instruments, construction details, foundation details, cable gland plate alongwith cable glands and all details mentioned in this specification.
3. Control Schematic Diagram along with grouping of different terminals for various functions.
4. Catalogue and technical information for instruments and devices with selected options clearly marked.
5. O&M Manuals.
6. “As Built” Drawing.
7. **CDs.**

7.0 MARKING AND PACKING

7.1 Panel with all instruments / devices mounted on it shall be suitably packed & protected for the entire period of despatch, storage and erection against impact, abrasion, corrossion, incidental damage due to vermin, sunlight, high temperature, rain moisture, humidity, dust, sea-water spray (where applicable) as well as rough handling and delays in Transit and storage in open.

8.0 APPLICABLE DATA SHEET FORMS

This document shall be read with one or more of the following data sheet forms :

- Data sheet A&B for Local Panels : Data sheet no. PES-145-54A-DS1-0
- Data sheet C for Local Panels : Data sheet no. PES-145-54A-DS2-0

Checklist for Serial Communication between maxDNA Systems and Foreign Device :BHEL

A Device Specific :

SN	Parameters	Options available	Remarks if any
1	Model No.& Make of Device		
2	Communications Link Options	<input type="checkbox"/> Multidrop <input type="checkbox"/> Peer to Peer <input type="checkbox"/> N/w topology attached	
3	Protocol Mode (Device is a)	<input type="checkbox"/> Master <input type="checkbox"/> Slave <input type="checkbox"/> Master/Slave	
4	Protocol	<input type="checkbox"/> RTU <input type="checkbox"/> ASCII <input type="checkbox"/> Other -----	
5	Master	<input type="checkbox"/> System maxDNA <input type="checkbox"/> Other -----	
6	Dist.bet.maxDNA System & Device*	<input type="checkbox"/> ----- Feet <input type="checkbox"/> ----- Meters	

B Electrical Specific :

1	Interface Type	<input type="checkbox"/> RS232 <input type="checkbox"/> RS422 <input type="checkbox"/> RS485	
2	Wiring at Device end	<input type="checkbox"/> 2 Wire <input type="checkbox"/> 4 Wire	
3	Transmission Channel	<input type="checkbox"/> Half Duplex <input type="checkbox"/> Full Duplex	
4	Baud Rates (bps)	<input type="checkbox"/> 1200 <input type="checkbox"/> 2400 <input type="checkbox"/> 4800 <input type="checkbox"/> 9600 <input type="checkbox"/> 19200	
5	Databits	<input type="checkbox"/> 8 <input type="checkbox"/> 7	
6	Stopbits	<input type="checkbox"/> 1 <input type="checkbox"/> 2	
7	Parity	<input type="checkbox"/> None <input type="checkbox"/> Odd <input type="checkbox"/> Even	
8	H/w & Software Handshake	<input type="checkbox"/> Yes <input type="checkbox"/> No	
9	Response Timeout time (Sec)	<input type="checkbox"/> ----- <input type="checkbox"/> Configurable timeout	
10	Data Formats Supported	<input type="checkbox"/> Boolean <input type="checkbox"/> Real <input type="checkbox"/> Char <input type="checkbox"/> Sn.Int <input type="checkbox"/> UnSn.Int	
11	Transmission mode	<input type="checkbox"/> Asynchronous <input type="checkbox"/> Synchronous	

C Application Specific : *

1	Primary Function*	<input type="checkbox"/> Data Acquisition <input type="checkbox"/> Data Acquisition & Control	
		<input type="checkbox"/> Download parameter sets	
2	Analog Points to read	-----Nos. <input type="checkbox"/> Details attached <input type="checkbox"/> Details not attached	
3	Analog Points to write	-----Nos. <input type="checkbox"/> Details attached <input type="checkbox"/> Details not attached	
4	Digital Points to read	-----Nos. <input type="checkbox"/> Details attached <input type="checkbox"/> Details not attached	
5	Digital Points to write	-----Nos. <input type="checkbox"/> Details attached <input type="checkbox"/> Details not attached	
6	Memory / Flag Points to read	-----Nos. <input type="checkbox"/> Details attached <input type="checkbox"/> Details not attached	
7	Memory / Flag Points to write	-----Nos. <input type="checkbox"/> Details attached <input type="checkbox"/> Details not attached	

D Hardware Specific :

1	Cable type	<input type="checkbox"/> Boolean cable <input type="checkbox"/> Twisted pair cable	
2	Cable Details Enclosed	<input type="checkbox"/> Yes <input type="checkbox"/> No	
3	Any specific Converter required	<input type="checkbox"/> Yes <input type="checkbox"/> No <input type="checkbox"/> Details enclosed	

E Device Documents :

1	Manufacturer's Documents*	<input type="checkbox"/> Tech., Spec. <input type="checkbox"/> Operating Manual	
---	---------------------------	---	--

***Notes:**

A6 To identify converter requirement and cable length.

C The sr.no.1 to 7 are reqd.to be furnished for interface impl. :such as Tagname,Description,point type, modbus(Register) address,EU,range & device (dlave) address

C1 What is the primary purpose of the communications link?

E1 Reqd. Contents : This document must provide an overview of the device including its intended use(a general technical,communication & electrical details)

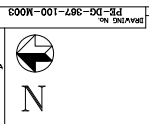
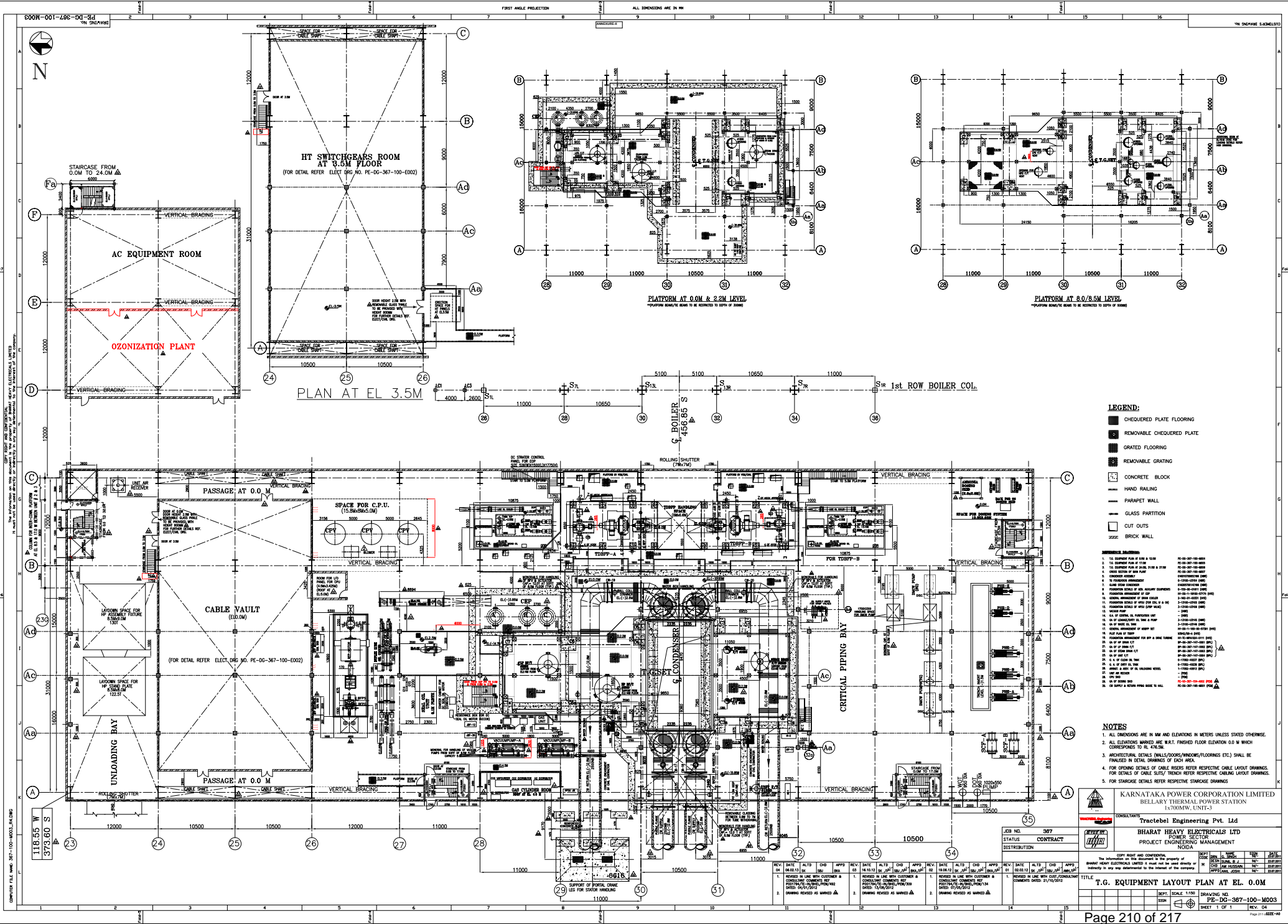

60000
100-100-10000
NO. DRAWING

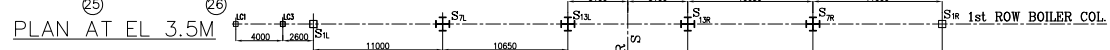
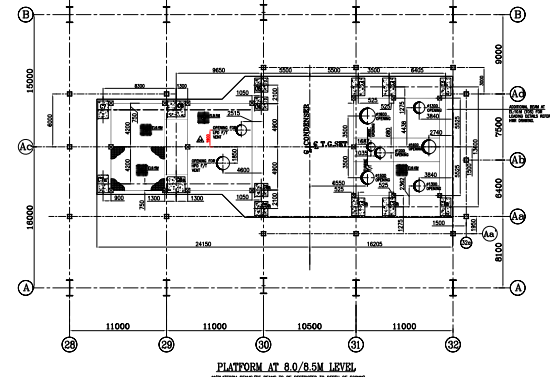
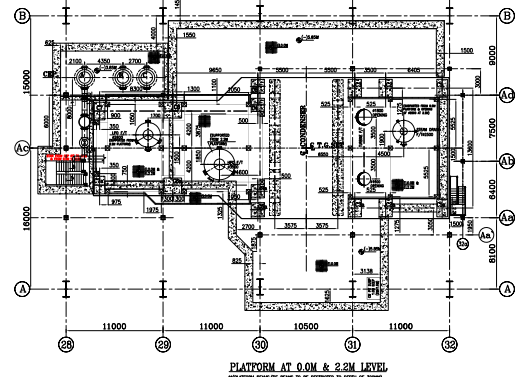
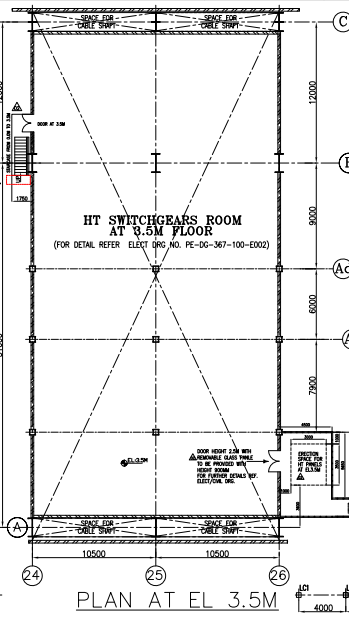
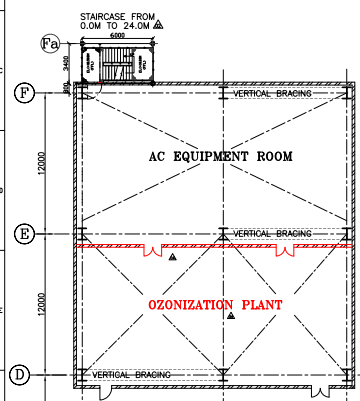

- LEGEND:**
- CHECKED FLOORING
 - REMOVABLE CHECKED FLOOR
 - GRATED FLOORING
 - REMOVABLE GRATING
 - CONCRETE BLOCK
 - HAND RAILING
 - PARAPET WALL
 - GLASS PARTITION
 - CUT OUTS
 - BRICK WALL

- REFERENCE DRAWINGS:**
- 1. IS GENERAL CODE OF PRACTICE
 - 2. IS CODE OF PRACTICE FOR ELECTRICAL ENGINEERING
 - 3. IS CODE OF PRACTICE FOR ELECTRICAL ENGINEERING
 - 4. IS CODE OF PRACTICE FOR ELECTRICAL ENGINEERING
 - 5. IS CODE OF PRACTICE FOR ELECTRICAL ENGINEERING
 - 6. IS CODE OF PRACTICE FOR ELECTRICAL ENGINEERING
 - 7. IS CODE OF PRACTICE FOR ELECTRICAL ENGINEERING
 - 8. IS CODE OF PRACTICE FOR ELECTRICAL ENGINEERING
 - 9. IS CODE OF PRACTICE FOR ELECTRICAL ENGINEERING
 - 10. IS CODE OF PRACTICE FOR ELECTRICAL ENGINEERING
 - 11. IS CODE OF PRACTICE FOR ELECTRICAL ENGINEERING
 - 12. IS CODE OF PRACTICE FOR ELECTRICAL ENGINEERING
 - 13. IS CODE OF PRACTICE FOR ELECTRICAL ENGINEERING
 - 14. IS CODE OF PRACTICE FOR ELECTRICAL ENGINEERING
 - 15. IS CODE OF PRACTICE FOR ELECTRICAL ENGINEERING
 - 16. IS CODE OF PRACTICE FOR ELECTRICAL ENGINEERING
 - 17. IS CODE OF PRACTICE FOR ELECTRICAL ENGINEERING
 - 18. IS CODE OF PRACTICE FOR ELECTRICAL ENGINEERING
 - 19. IS CODE OF PRACTICE FOR ELECTRICAL ENGINEERING
 - 20. IS CODE OF PRACTICE FOR ELECTRICAL ENGINEERING
 - 21. IS CODE OF PRACTICE FOR ELECTRICAL ENGINEERING
 - 22. IS CODE OF PRACTICE FOR ELECTRICAL ENGINEERING
 - 23. IS CODE OF PRACTICE FOR ELECTRICAL ENGINEERING
 - 24. IS CODE OF PRACTICE FOR ELECTRICAL ENGINEERING
 - 25. IS CODE OF PRACTICE FOR ELECTRICAL ENGINEERING
 - 26. IS CODE OF PRACTICE FOR ELECTRICAL ENGINEERING
 - 27. IS CODE OF PRACTICE FOR ELECTRICAL ENGINEERING
 - 28. IS CODE OF PRACTICE FOR ELECTRICAL ENGINEERING
 - 29. IS CODE OF PRACTICE FOR ELECTRICAL ENGINEERING
 - 30. IS CODE OF PRACTICE FOR ELECTRICAL ENGINEERING
 - 31. IS CODE OF PRACTICE FOR ELECTRICAL ENGINEERING
 - 32. IS CODE OF PRACTICE FOR ELECTRICAL ENGINEERING
 - 33. IS CODE OF PRACTICE FOR ELECTRICAL ENGINEERING
 - 34. IS CODE OF PRACTICE FOR ELECTRICAL ENGINEERING
 - 35. IS CODE OF PRACTICE FOR ELECTRICAL ENGINEERING
 - 36. IS CODE OF PRACTICE FOR ELECTRICAL ENGINEERING
 - 37. IS CODE OF PRACTICE FOR ELECTRICAL ENGINEERING
 - 38. IS CODE OF PRACTICE FOR ELECTRICAL ENGINEERING
 - 39. IS CODE OF PRACTICE FOR ELECTRICAL ENGINEERING
 - 40. IS CODE OF PRACTICE FOR ELECTRICAL ENGINEERING
 - 41. IS CODE OF PRACTICE FOR ELECTRICAL ENGINEERING
 - 42. IS CODE OF PRACTICE FOR ELECTRICAL ENGINEERING
 - 43. IS CODE OF PRACTICE FOR ELECTRICAL ENGINEERING
 - 44. IS CODE OF PRACTICE FOR ELECTRICAL ENGINEERING
 - 45. IS CODE OF PRACTICE FOR ELECTRICAL ENGINEERING
 - 46. IS CODE OF PRACTICE FOR ELECTRICAL ENGINEERING
 - 47. IS CODE OF PRACTICE FOR ELECTRICAL ENGINEERING
 - 48. IS CODE OF PRACTICE FOR ELECTRICAL ENGINEERING
 - 49. IS CODE OF PRACTICE FOR ELECTRICAL ENGINEERING
 - 50. IS CODE OF PRACTICE FOR ELECTRICAL ENGINEERING
 - 51. IS CODE OF PRACTICE FOR ELECTRICAL ENGINEERING
 - 52. IS CODE OF PRACTICE FOR ELECTRICAL ENGINEERING
 - 53. IS CODE OF PRACTICE FOR ELECTRICAL ENGINEERING
 - 54. IS CODE OF PRACTICE FOR ELECTRICAL ENGINEERING
 - 55. IS CODE OF PRACTICE FOR ELECTRICAL ENGINEERING
 - 56. IS CODE OF PRACTICE FOR ELECTRICAL ENGINEERING
 - 57. IS CODE OF PRACTICE FOR ELECTRICAL ENGINEERING
 - 58. IS CODE OF PRACTICE FOR ELECTRICAL ENGINEERING
 - 59. IS CODE OF PRACTICE FOR ELECTRICAL ENGINEERING
 - 60. IS CODE OF PRACTICE FOR ELECTRICAL ENGINEERING
 - 61. IS CODE OF PRACTICE FOR ELECTRICAL ENGINEERING
 - 62. IS CODE OF PRACTICE FOR ELECTRICAL ENGINEERING
 - 63. IS CODE OF PRACTICE FOR ELECTRICAL ENGINEERING
 - 64. IS CODE OF PRACTICE FOR ELECTRICAL ENGINEERING
 - 65. IS CODE OF PRACTICE FOR ELECTRICAL ENGINEERING
 - 66. IS CODE OF PRACTICE FOR ELECTRICAL ENGINEERING
 - 67. IS CODE OF PRACTICE FOR ELECTRICAL ENGINEERING
 - 68. IS CODE OF PRACTICE FOR ELECTRICAL ENGINEERING
 - 69. IS CODE OF PRACTICE FOR ELECTRICAL ENGINEERING
 - 70. IS CODE OF PRACTICE FOR ELECTRICAL ENGINEERING
 - 71. IS CODE OF PRACTICE FOR ELECTRICAL ENGINEERING
 - 72. IS CODE OF PRACTICE FOR ELECTRICAL ENGINEERING
 - 73. IS CODE OF PRACTICE FOR ELECTRICAL ENGINEERING
 - 74. IS CODE OF PRACTICE FOR ELECTRICAL ENGINEERING
 - 75. IS CODE OF PRACTICE FOR ELECTRICAL ENGINEERING
 - 76. IS CODE OF PRACTICE FOR ELECTRICAL ENGINEERING
 - 77. IS CODE OF PRACTICE FOR ELECTRICAL ENGINEERING
 - 78. IS CODE OF PRACTICE FOR ELECTRICAL ENGINEERING
 - 79. IS CODE OF PRACTICE FOR ELECTRICAL ENGINEERING
 - 80. IS CODE OF PRACTICE FOR ELECTRICAL ENGINEERING
 - 81. IS CODE OF PRACTICE FOR ELECTRICAL ENGINEERING
 - 82. IS CODE OF PRACTICE FOR ELECTRICAL ENGINEERING
 - 83. IS CODE OF PRACTICE FOR ELECTRICAL ENGINEERING
 - 84. IS CODE OF PRACTICE FOR ELECTRICAL ENGINEERING
 - 85. IS CODE OF PRACTICE FOR ELECTRICAL ENGINEERING
 - 86. IS CODE OF PRACTICE FOR ELECTRICAL ENGINEERING
 - 87. IS CODE OF PRACTICE FOR ELECTRICAL ENGINEERING
 - 88. IS CODE OF PRACTICE FOR ELECTRICAL ENGINEERING
 - 89. IS CODE OF PRACTICE FOR ELECTRICAL ENGINEERING
 - 90. IS CODE OF PRACTICE FOR ELECTRICAL ENGINEERING
 - 91. IS CODE OF PRACTICE FOR ELECTRICAL ENGINEERING
 - 92. IS CODE OF PRACTICE FOR ELECTRICAL ENGINEERING
 - 93. IS CODE OF PRACTICE FOR ELECTRICAL ENGINEERING
 - 94. IS CODE OF PRACTICE FOR ELECTRICAL ENGINEERING
 - 95. IS CODE OF PRACTICE FOR ELECTRICAL ENGINEERING
 - 96. IS CODE OF PRACTICE FOR ELECTRICAL ENGINEERING
 - 97. IS CODE OF PRACTICE FOR ELECTRICAL ENGINEERING
 - 98. IS CODE OF PRACTICE FOR ELECTRICAL ENGINEERING
 - 99. IS CODE OF PRACTICE FOR ELECTRICAL ENGINEERING
 - 100. IS CODE OF PRACTICE FOR ELECTRICAL ENGINEERING

- NOTES:**
1. ALL DIMENSIONS ARE IN MM AND ELEVATIONS IN METERS UNLESS STATED OTHERWISE.
 2. ALL ELECTRICAL WORK SHALL BE FINISHED FLOOR ELEVATION UNLESS OTHERWISE SPECIFIED.
 3. ALL ELECTRICAL WORK SHALL BE FINISHED FLOOR ELEVATION UNLESS OTHERWISE SPECIFIED.
 4. FOR CHANGING DETAILS OF CABLE TRAYS REFER RESPECTIVE CABLE LAYOUT DRAWINGS.
 5. FOR STORAGE DETAILS REFER RESPECTIVE STORAGE DRAWINGS.

KARNATAKA POWER CORPORATION LIMITED
BELLARY THERMAL POWER STATION
15700W, UNITS-3

Tracebel Engineering Pvt. Ltd
BHARAT HEAVY ELECTRICALS LTD
PROJECT ENGINEERING MANAGEMENT

JOB NO. SEPT
STATUS CONTRACT
DISTRIBUTION

T.G. EQUIPMENT LAYOUT PLAN AT EL. 0.0M

REVISIONS:

NO.	DATE	BY	CHKD.	APPD.	REVISION
1					ISSUED IN LINE WITH CUSTOMER'S REQUIREMENTS FOR THE PROJECT.
2					ISSUED IN LINE WITH CUSTOMER'S REQUIREMENTS FOR THE PROJECT.
3					ISSUED IN LINE WITH CUSTOMER'S REQUIREMENTS FOR THE PROJECT.