

-
- | | | | |
|-----|---|---|---|
| 7. | Turn Down | : | 100:1 |
| 8. | Accuracy | : | ± 0.2 % of measured value |
| 9. | Housing | : | IP 65 (Explosion proof) |
| 10. | Nameplate | : | Tag number, service engraved in stainless steel tag plate |
| 11. | Accessories | : | a) Handheld calibrator
b) Mounting U-bolts, nuts, bolts, prefab cable etc
c) $\frac{1}{2}$ "NPT cable gland |
| 12. | Adjustment/Calibration/
/Maintenance | : | From handheld calibrator/ HART management system |
| 13. | Applications | : | Fuel Oil service |

1.05.00 RADAR TYPE LEVEL MEASUREMENT

- | | | | |
|----|---------------------------|---|---|
| 1. | Type | : | Smart (HART Compatible) |
| 2. | Antenna | : | Co axial / guided wave radar /-Overspill protection |
| 3. | Principle | : | TDR (Time Domain Reflectometry) |
| 4. | Communication | : | Two wire 4-20mA DC with HART |
| 5. | Environmental temperature | : | 0 – 50 °C |
| 6. | Enclosure | : | IP-65 (Explosion proof for NEC Class-1, Division 1 area) |
| 7. | Calibration | : | a) Self calibration with internal reference
b) Zero & Span calibration |
| 8. | Process Connection | : | External cage mounting
Flanged /screwed |
| 9. | Electronic Housing | : | Epoxy painted Die-Cast aluminium |

		alloy
10. Antenna / Flange assembly	:	316 SS or Hestalloy (as required)
11. Power supply	:	24 V DC
12. Output Indicator	:	LCD
13. Accuracy	:	5 mm or 0.1% of probe length
14. Accessories	:	a) Handheld calibrator
	:	b) Counter Flange, nuts, bolts, gaskets etc
	:	c) ½"NPT cable gland
	:	d) SS Nameplate
15. Adjustment/Calibration/ Maintenance	:	From handheld calibrator/ HART management system
16. Applications	:	Vessels under vacuum or low pressure applications, solid levels
1.06.00	ULTRASONIC LEVEL TRANSMITTER	
1. Type	:	Microprocessor based, 2-wire, Smart (HART Compatible)
2. Operating Principle	:	Detection of reflected ultrasonic pulse
3. Output Signal	:	4-20 mA DC along with superimposed digital signal
4. Operating frequency	:	10 KHz to 50 KHz (typical)
5. Display	:	LCD
6. Temperature Compensation	:	Built in –Programmable
7. Power supply	:	24 V DC
8. Enclosure	:	SS, IP-65 (Explosion proof for NEC Class-1, Division 1 area)

-
9. Zero & Span : Continuous, tamper proof, remote as well locally adjustable. It shall be possible to calibrate the instrument without any level in the sump/ tank
10. Accuracy & Repeatability : 0.15 % of span or better
11. Resolution : 0.1 % of span
12. Operating temp. : Transmitter- 500 C and Sensor - 800 C
13. MOC Sensor : SS-316/Body- PVC and Face – Polyurethane
14. Mounting : 4” Flanged/ 2” NPT for sensor and Transmitter on panel
15. Accessories :
- a) Handheld calibrator
 - b) Weather canopy for protection from direct sunlight and direct rain
 - c) ½”NPT cable gland
 - d) All mounting hardware (SS-316), Prefab cable
 - e) SS Nameplate
16. Diagnosis : On-line
17. Status Indication : Power On, HI, HI-HI, Lo, LO-LO, Fault
18. Output Contacts : 2 SPDT, 230V, 5A
19. Adjustment/Calibration/ Maintenance : From handheld calibrator/ HART management system
20. Applications : Coal Bunker, Water Service etc.

1.07.00 ULTRASONIC FLOW TRANSMITTER

1. Type : Ultrasonic – Clamp On
2. Accuracy : +/- 1 % of reading
3. Repeatability : +/- 0.3 % of reading
4. Rangeability : 400 : 1
5. Output Signal : 4-20 mA DC with HART
6. Measured Parameter : Volumetric flow, Totalized flow and flow Velocity
7. Display : LCD with internal Key Pad (Flow rate & Totalization)
8. Power Supply : 24 V DC (2 Wire)
9. Enclosure : SS (IP- 68 – Submersible)
10. Mounting : SS Chain or Strap
11. Accessories
 1. Handheld calibrator
 2. ½"NPT cable gland
 3. Transducer cable
 4. All mounting hardware (SS-316)
 5. SS Nameplate
12. Adjustment/Calibration/ Maintenance : From handheld calibrator/ HART management system
13. Applications : Plant water service

Note: Multi-path insertion type (minimum 4 path) Ultrasonic Flow meter shall be provided for Raw water/ Cooling Water flow measurements.

2.00.00 HART HAND HELD CALIBRATOR

Hand held calibrators (5 nos. for each type) shall be provided for adjustment/ calibration/maintenance of the HART compatible

transmitters. The hand held calibrator shall be suitable for all types of transmitters supplied in the package. If one type of hand held type calibrator is not suitable for communicating with all types of transmitters then separate hand held calibrator will be provided.

3.00.00 **PROCESS ACTUATED SWITCHES**

3.01.00 PRESSURE SWITCH

1. Type :
 - i. Piston for high pressure application
 - ii. Bellow / Diaphragm for low pressure application
2. Sensing element : SS-316.
material All other wetted part SS316
3. Case Material : SS \dagger
4. Setter Scale : Black graduation on white linear scale.
Graduation 0-100% with red pointer for set points
5. Over range : 150 % of maximum pressure
6. Adjustments :
 - a) Internal Set Point
 - b) Differential adjustment
7. End Connection : 1/2" NPT bottom connected
8. Switch configuration : Two SPDT (240V, 5A AC/220V, 0.5A DC)
9. Switch Type : Snap acting, shock & vibration proof
10. Terminal Block : Suitable for full ring lugs
11. Enclosure Class : IP-65 (Explosion proof for NEC Class-1, Division 1 area)
12. Performance :
 - a) Repeat accuracy \pm 1.0%
 - b) Accuracy of Setting Indication of \pm 1.5%
13. Ambient temperature : 0 – 50 Deg.C

14. Nameplate : Tag number, service engraved in SS tag plate
15. Accessories : a) Silicon oil/ Fluorolub filled Remote diaphragm seal with SS-316 capillary for corrosive/ viscous/ solid bearing or slurry type fluid applications
b) Snubbers for pulsating fluid applications
c) Siphons for steam and hot water services
d) Retention ring and screws for surface mounting
e) 1/2" NPT 2 Valve SS-316 barstock manifold
f) 1/2" NPT cable gland
16. Applications : During Detail Engineering on Owner's approval

3.02.00 DIFFERENTIAL PRESSURE SWITCH

1. Type : i. Piston for high pressure application
ii. Bellow / Diaphragm for low pressure application
2. Sensing element material : SS-316.
All other wetted part SS316
3. Case Material : SS
4. Setter Scale : Black graduation on white linear scale.
Graduation 0-100% with red pointer for set points
5. Over range : 150 % of maximum pressure

-
6. Adjustments : a) Internal Set Point
: b) Differential adjustment
7. End Connection : 1/2" NPT bottom/ back connected
8. Switch configuration : Two SPDT (240V, 5A AC/220V, 0.5A DC)
9. Switch Type : Snap acting, shock & vibration proof
10. Terminal Block : Suitable for full ring lugs
11. Enclosure Class : IP-65 (Explosion proof for NEC Class-1, Division 1 area)
12. Performance : a) Repeat accuracy $\pm 1.0\%$
: b) Accuracy of Setting Indication of $\pm 1.5\%$
13. Ambient temperature : 0 – 50 Deg.C
14. Nameplate : Tag number, service engraved in SS tag plate
15. Accessories : a) Silicon oil/ Fluorolub filled Remote diaphragm seal with SS-316 capillary Diaphragm seals for corrosive/ viscous/ solid bearing or slurry type fluid applications
: b) Snubbers for pulsating fluid applications
: c) Siphons for steam and hot water services
: d) Retention ring and screws for surface mounting
: e) 1/2" NPT 5 Valve SS-316 barstock manifold
: f) 1/2" NPT cable gland
16. Applications : During Detail Engineering on Owner's

approval

3.03.00 LEVEL SWITCH

3.03.01 FLOAT OPERATED

1. Float material : SS-316
2. Wetted parts : SS-316
3. Float chamber : Stainless steel/Carbon steel,
construction welded
4. Float chamber : Side mounted
mounting
5. Fluid connection : Side – Side
6. Fluid connection size : 1" ANSI RF Flange (rubber line, if
required)
7. Drain : ½ inch NPT with Plug
8. Pressure rating of : Minimum 1.5 times of design pressure
chamber
9. Repeatability : +/- 1.5 mm or better
10. Switch housing : Stainless Steel
11. Switch housing type : IP- 65
12. Type of switch : Snap acting magnetically operated
hermetically sealed
13. Switch configuration : 2 SPDT (5A, 240 V AC, 0.5A, 220V DC)
14. Accessories : a) Counter flange, nuts
& bolts, suitable
gasket etc.
b) Steel globe type
drain valve
c) ½"NPT cable gland

d) Stainless steel nameplate with alpha-numeric engraved for service and tag

15. Application : During Detail Engineering on Owner's approval

3.04.00 FLOW SWITCH

1. Type : Paddle /Piston/Disk
2. Wetted part material : Stainless steel or Hastelloy for acidic application
3. End connection :
 - a) Threaded upto 1" line size with integral Tee
 - b) Flanged for line size > 1 ½"
4. Enclosure material : Stainless Steel
5. Enclosure class : IP 65
6. Switch configuration : 2 SPDT (5A, 240 V AC, 0.5A, 220V DC)
7. Repeatability : 2%
8. Cable connection : ½"NPTF
9. Accessories :
 - a) Tee, Counter flange, nuts & bolts, suitable gasket etc
 - b) ½"NPT cable gland
 - c) Stainless steel nameplate with alpha-numeric engraved for service and tag

3.05.00 RF LEVEL SWITCH

-
- | | | |
|-----------------------------|---|--|
| 1. Type | : | RADIO FREQUENCY |
| Sensing probe | | |
| 2. Material | : | SS-316 |
| 3. Mounting | : | Threaded |
| 4. Application | : | 250°C (Max.) |
| Temperature | | |
| Electronic Controller | | |
| 5. Input Supply Voltage | : | 240V AC \pm 10%, 50 Hz. |
| 6. Relay Output | : | 2 SPDT (240V AC, 5A) |
| 7. Ambient Temperature | : | 50 °C |
| 8. Enclosure Protection | : | IP-66 |
| 9. Enclosure Housing | : | SS |
| | | Normal Level |
| | | Power On |
| 10. Local LED Indication | : | Alarm Level |
| | | Probe Healthy |
| 11. Switching Repeatability | : | \pm 0.5% |
| | | Co-axial cable for probe connection to |
| | | controller |
| 12. Accessories | : | SS Tag plate |
| | | 1/2" NPT Cable Glands |
| 13. Application | : | Solid level |

3.06.00 CONDUCTIVITY TYPE LEVEL SWITCH

- | | | |
|------------------|---|-----------------------------|
| 1. Type | : | Conductivity discrimination |
| 2. Probe MOC | : | SS-316 |
| 3. Mounting | : | Flanged on external cage |
| 4. Application | : | 250°C (Max.) |
| Temperature | | |
| 5. Test Pressure | : | Two times rated pressure |

6. Input Supply Voltage : 240V AC \pm 10%, 50 Hz.
Four independent channel with
7. Input : selectable switching threshold for water conductivity
8. Relay Output : 2 SPDT (240V AC, 5A)
9. Ambient Temperature : 50 °C
10. Enclosure Protection : IP-65 (Explosion proof for NEC Class-1, Division-1 area)
11. Enclosure Housing : SS
HI,LO, HIGH-HIGH, LOW-LOW
12. Local LED Indication : Power
Fault
13. Accessories : a) Interconnecting cable from probe to electronics
b) Mounting accessories
c) External cage
d) Washer & Gasket
e) 1/2" NPT Cable Glands
f) SS Tag Plate
14. Application : During Detail Engineering on Owner's approval

3.07.00 TEMPERATURE SWITCH

1. Type : Bimetallic or gas filled
2. Sensing Element : SS-316
Material
3. Bulb Material : SS-316
4. Capillary : Stainless Steel armored

-
5. Movement Material : Stainless Steel
6. Case material : Stainless Steel with neoprene gasket and clear glass where applicable cover conforming to IP-65. (Explosion proof for NEC Class-1, Division 1 area).
- 7.. Scale : Black graduation on white linear scale. Graduation 0-100% with red pointer for set points
8. Over range Protection : 120 %
9. Instrument connection : Bottom
10. Switch configuration : Two SPDT (240V, 5A AC/220V, 0.5A DC)
11. Switch type : Snap acting, shock and vibration-proof
12. Adjustability : Internal Set point adjustable over span range
13. Compensation : a) Capillary compensation with invar wire throughout the capillary length
b) Case compensation
14. Performance
- a) Scale Accuracy : ± 1.0 % of full scale
- b) Repeatability : < 0.5 % of full range
- c) Response time : Less than 40 seconds with thermowell
15. Capillary length : 5 meters (minimum) for local mounting/15 meters for local panel mounting
16. Nameplate : Tag number, service engraved in stainless steel tag plate
17. Accessories : Mounting accessories, 1/2" NPT cable gland
18. Applications : During Detail Engineering on Owner's

approval

4.00.00 **LOCAL INSTRUMENTS**

4.01.00 PRESSURE GAUGE AND DIFFERENTIAL PRESSURE GAUGE

1. Type : Bourdon/Bellows/Diaphragm
2. Sensing & Socket : SS-316
3. Movement Material : SS-316
4. Case Material : Stainless steel. IP-65 (Explosion proof for NEC Class-1, Division 1 area)
5. Dial Size : Generally 150 mm
6. Scale : Black lettering on white in 270 O arc.
7. Window : Shatterproof glass
8. Range Selection : Normal process pressure: 50~70 % of range
9. Over-range Protection : 125% of maximum range by internal stop. External stop at zero
For Zero adjustment (Micrometer screw external)
10. Adjustment : For Range adjustment (Micrometer screw internal).
11. Element Connection : Argon welding
12. Process Connection : 1/2" NPT (M) Bottom for local, back for panel mounting
13. Performance : Accuracy of ± 1.0 % of span or better
14. Operating ambient : 0 - 50 °C
15. Safety Feature : Blow out disc /diaphragm at the back
16. Accessories :
 - a) Snubbers for pulsating fluid application.discharge
 - b) Stainless steel Diaphragm seals

- for corrosive/ viscous/ solid bearing or slurry type fluid applications
- c) 3-Way SS316 Gauge cock for pressure gauges
- 5-valve SS316 manifold from
- d) barstock for differential pressure gauge
- e) Siphons for steam and hot water services
17. Nameplate : Tag number, service engraved in stainless steel tag plate

4.02.00 LEVEL INDICATOR (FLOAT & BOARD TYPE)

1. Type : Float and Board
2. Float Material : SS-316
3. Float Cable : SS-316
4. Indicator Assembly : Epoxy painted Aluminium
5. Guide wire spring assembly : SS-316 (2 Nos.)
6. Guide Wire Anchor : SS-316
Anodized Aluminium with engraved marking (Minimum graduation 10mm),
7. Scale Board :
mounting brackets and suitable hardware required as per tank height
8. Elbow Assembly : Anodized Aluminium
9. Flanges : RF , ANSI 150 , SS (3 Nos.)
10. Accuracy : ± 10 mm or better
11. Accessories : All mounting accessories including counter flange, nuts & bolts, suitable

gasket etc. as applicable, SS Tag plate

4.03.00 GAUGE GLASS

1. Type : Reflex /Transparent
2. Material :
Glass : Toughened borosilicate resistant to thermal shock
Body Material : ~~Carbon Steel~~ Stainless Steel
Enclosure : IP-65 (Explosion proof for NEC Class-1, Division 1 area)
3. Integral cocks & valves/Fittings :
i. SS 316
Rubber lined corrosion resistant
4. :
ii. stainless steel (for DM/RO service)
5. Vessel Connection : ANSI Flanged SS316
6. Accessories :
i. Integral cocks
ii. Drain Valves
iii. Companion Flanges, Bolts, nuts, gaskets, SS Tag plate
iv. Illuminating lamps, Mica shield as required
v. Calibrated scale
7. Pressure rating : Twice the maximum working pressure
8. Temperature : 300 °C
For larger lengths (greater than 1200mm), additional gauge glasses
9. Other details : shall be provided with minimum of 50 mm overlap.

-
- 4.04.00 SLIGHT GLASS
1. Type : Flap-type.
 2. End connection : Screwed / Flanged
 3. Material
 - a) Body : SS- 304
 - b) Cover plate : SS- 304
 - c) Indicator : SS- 316
 4. Sight Glass : Toughened Borosilicate
 5. Gasket : Neoprene
 6. Bolts & Nuts : High tensile steel.
 7. Hydraulic Test Pressure : 1.5 times maximum working pressure
 8. Accessories : Companion Flanges, Bolts, nuts, gaskets as required, SS Tag plate.
- 4.05.00 ROTAMETER
1. Type : ON-LINE for line upto and including 50 mm NB.
: Borosilicate BY-PASS for line size above 50 NB
 2. Metering tube : Toughened Borosilicate
 3. Float : SS-316
 4. End fittings : SS-316
 5. Packing material : Teflon / PTFE
 6. Casing : Stainless Steel
 7. Gland Rings : Stainless Steel
/Followers/ Other :
wetted parts
 8. Orifice Plate : Stainless Steel (for bypass type)
 9. Operating Temperature : 0-50 Deg. c

-
- | | | |
|------------------------|---|--|
| 10. Test Pressure | : | 200% of maximum operating pressure |
| 11. Scale | : | 250 mm nominal length |
| 12. Graduation | : | Direct reading |
| 13. Process Connection | : | Flanged (RF) to line size as per ANSI standards (150#) |
| 14. Tapping | : | D & D/2 |
| 15. Accuracy | : | +/- 2% of full scale reading |
| 16. Reproducibility | : | Within 0.5% of instantaneous reading |
| 17. Accessories | : | SS Tag Plate, orifice plate |

5.00.00

TEMPERATURE ELEMENTS & ACCESSORIES

5.01.00

RESISTANCE TEMPERATURE DETECTOR

- | | | |
|----------------------------------|---|--|
| 1. Type | : | Platinum (Duplex), Ungrounded |
| 2. Platinum (Duplex), Ungrounded | : | 100 ohm at 0 °C |
| 3. Base | : | Wound on ceramic (anti-inductive) |
| 4. Wiring | : | 3 Wire |
| 5. Protecting Tube | : | |
| a) O.D. | : | 6 mm |
| b) Material | : | SS-316, Seamless |
| c) Filling | : | Magnesium oxide (Purity above 99.4%). |
| 6. Response time | : | a) 15 sec. (bare).
b) 30 sec. (with thermowell) |
| 7. Calibration | : | DIN 43760 |
| 8. Accuracy | : | ± 0.5% |
| 9. Head | : | |
| a) Type | : | IP-65 universal screwed type |

- b) Material : Stainless Steel
- c) Terminal blocks : Nickel plated Brass-screw type / silver plated
- d) Cable connection : ½" NPT gland and grommet
- e) Others : Terminal head cover with SS chain and suitable gasket.
- Head of TE to be provided with sufficient space and arrangement to mount head mounted temperature transmitter (as applicable).
- Adjustable nipple-union-nipple [1/2" Sch 80 X ½" NPT] with thermowell connection
10. Accessories : a) Compression fittings/unions
- b) Flanges etc. (for flanged connections only)
- c) Thermowell (As specified below)
- d)
11. Thermowell connection : ½" NPT (M) or 150 RF Flanged
12. Nameplate : Tag number, service engraved in stainless steel tag plate

Note: The specifications for RTDs of winding/ bearing of motor/pump, can be as per their manufacturer standards. The manufacturer shall submit the adequate supporting documents for establishing their standard practice. However, the type of RTD shall be Pt-100.

5.02.00 THERMOCOUPLES

1. Type :
 - a) 16 SWG wire of Chromel Alumel) (Type-K)
 - b) Duplex
 - c) Ungrounded
2. Protecting Tube
 - a) O.D. : 6 mm
 - b) Material : SS-316, Seamless
 - c) Filling : Magnesium oxide (Purity above 99.4%).
3. Response time :
 - a) < 20 seconds for measurement
 - b) < 10 seconds for control
4. Accuracy : $\pm 1.1^{\circ} \text{C}$ up to 300°C & 0.4% of measured temperature range above 300°C
5. Head
 - a) Type : IP-65 universal screwed type
 - b) Material : Stainless Steel
 - c) Terminal blocks : Nickel plated Brass-screw type / silver plated
 - d) Cable connection : $\frac{1}{2}$ " NPT gland and grommet
6. e) Others : Terminal head cover with SS chain and suitable gasket.

Head of TE to be provided with sufficient space and arrangement to mount head mounted temperature transmitter (as applicable).

7. Accessories :
- a) Adjustable nipple-union-nipple [1/2" Sch 80 X 1/2" NPT] with thermowell connection
 - b) Compression fittings/unions
 - c) Flanges etc. (for flanged connections only)
 - d) Thermowell (As specified below)
8. Thermowell connection : 1/2" NPT (M) or 150 RF Flanged
9. Nameplate : Tag number, service engraved in stainless steel tag plate

5.03.00 TEMPERATURE GAUGE

1. Type : Expansion type (Liquid filled system)
2. Sensing Element Material : Bourdon – SS-316
3. Bulb and Capillary Material : SS-316
4. Capillary Tubing : Inner sheath - solid drawn Material
copper tube
Outer sheath - PVC tube
5. Movement Materials : Stainless Steel / Direct Bourdon tip connection to pointer spindle
6. Case Material : Stainless Steel stove enameled, black finish, threaded bezel ring, clear glass

- cover conforming to IP 65.
7. Dial size : 150 mm
 8. Scale : Black lettering on white background in
270 Deg.C arc
 9. Over range protection : 125 percent of FSD
 10. Capillary Glanding : 1/2" NPT(M) x compression fitting (SS)
to suit capillary
 11. Instrument Connection : Bottom connection for local mounting,
back connection for panel mounting
 12. Process Connection : 1/2" NPT (M) or 150 RF Flanged
 13. Extension Neck Length : 50 mm
 14. Compensation : a) Capillary compensation
 15. : b) Case compensation
 16. Performance : a) Accuracy : + /- 1.0 percent of
full scale Deflection
: b) Repeatability : Less than 0.5
percent of full range
: c) Response time: 15 seconds
(max.).
 17. Capillary length : 3.0 meters (local) / 15.0 metres (local
panel)
 18. Other features : Shatter proof glass
 19. Nameplate : Tag number, service engraved in
stainless steel tag plate
 20. Accessories : SS316 Thermowell

5.04.00 THERMOWELL

1. Material : SS-316
2. Manufacture : Drilled from bar stock, Hex Head,
Tapered design (As per ASME PTC
19.3)

3. Process connection : M33x2
4. Certification : Not applicable
5. Bore concentricity : +5% of wall thickness
6. Identification mark : Tag number punched on head
7. Surface treatment : Polish after machining
8. Element connection : ½" NPT (M) or 150 RF Flanged
9. Head : Hex
10. Length of the hex head : 31.75 mm (min.)
11. Accessories : SS Plug and chain for test thermo wells
SS Nameplate, Flange with companion
flange & all required accessories for
flanged connections.

Note: Wake frequency calculations shall be furnished for all thermowells for approval.

Thermowells shall be designed such that the resonant frequency is above the exciting frequencies generated by vortex shedding in the process fluid.

5.05.00 METAL TEMPERATURE THERMOCOUPLE

1. Measuring medium : Metal temperature
2. Type : Chromel Alumel (Type-K)
Duplex, Ungrounded
3. Insulation : Mineral Insulation Magnesium Oxide
4. Wire gauge : 16 AWG
5. Protective sheath : SS
6. Protective sheath :
diameter : 8 mm O.D.
7. Characteristics : Special limits of error as in ANSI
thermocouple MC 96.01
8. Accessories : ½" BSP SS sliding end connector, weld
pad, clamps of heat resistant steel

1. Type : Hydrometer Type
2. Mounting : On line
3. Accuracy : +/- 2% of range
4. Scale : Black letter on white scale
5. End connection : PVC flange

9.06.00 DENSITY/ CONCENTRATION METER

1. Wetted Part : Stainless Steel
2. Enclosure : Stainless Steel (IP-65)
3. Power Supply : 24 V DC
4. Output signal : 4-20 mA DC (isolated) into 600 ohms
5. Accuracy : ± 0.001 g/cc
6. Indication : LCD display
7. Temp. Compensation : Integral
8. Accessories : Mounting hardware, integral amplifier (if required), cable glands, tag plate etc.

10.00.00 SOLENOID VALVES

1. Operating Principle : Electromagnetic (noiseless)
2. Coil voltage rating : 240 V AC /24 V DC (as required)
3. Ways : 2/3/4 way
4. Port size : 1/4" NPT all ports
5. Body : SS bar stock
- Trim : SS-316
6. Duty : Suitable for continuous energization
7. Sealing : Airtight and leak proof
8. Ambient Temperature : 0 - 50 ° C

- | | | | |
|-----|-------------------|---|--|
| 9. | Fluid Temperature | : | 0-150 ° C (approx.) |
| 10. | Coil Enclosure | : | Stainless Steel |
| 11. | Insulation | : | Class-H |
| 12. | Coil Casing | : | IP-65 (Explosion proof for NEC Class-1, Division-1 area) |
| 13. | Mounting | : | On pipe or on panel |
| 14. | Cable Connection | : | ½" NPT |
| 15. | Accessories | : | Cable glands, SS Tag plate |



Technical specification for
CONTROL & INSTRUMENTATION

1X800 MW KOTHAGUDEM

SPEC NO.: **PE-TS-410-145-I**

VOLUME

SECTION

REV. NO.

00

DATE : 10.03.2015

SHEET

OF

Instrumentation Quality Plan



STANDARD CHECK LIST FOR C&I INSTRUMENTS (for Maux Pkgs)

CHECK LIST FOR PRESSURE SWITCH

Sl. No.	Test / Checks	Quantum of check	Reference Doc. / Acceptance Norms	Agency **			Remarks		
				M	C	B			
1	CHECK FOR	SEE NOTE-1 BELOW	APPROVED SPEC./ DATA SHEETS	P	V	V			
	1.1 MODEL NO/TAG NO								
	1.2 RANGE								
	1.3 END CONN								
	1.4 NO. OF CONTACT								
2	CALIBRATION					P	V	V	
	2.1 REPEATABILITY								
	2.2 SET POINT ADJUSTMENT								
	2.3 DIFFERENTIAL								
3	OVER PR & LEAK TEST					P	V	V	
4	ELECT. INSULATION/HV TEST	ONE			P	V	V		
5	REVIEW OF TC FOR MATERIALS OF	FOR LOT			V	V	V		
	5.1 SENSOR								
	5.2 MOVEMENT								
	5.3 PROCESS CONNECTION								
	5.4 HOUSING								
6	REVIEW OF TC FOR DEGREE OF PROTECTION	TYPE TEST			V	V	V		
7	REVIEW OF TC OF MICROSWITCH	FOR LOT			V	V	V		

** M = Manufacturer / Sub-contractor, C = Contractor / Nominated Inspecting Agency, B = BHEL, P = Perform, W = Witness, V = Verification

Note :

1. Quantum of check shall be as below :
100 % - By Manufacturer
2. Manufacturer to carry out ROUTINE TEST on 100 %.
3. Contractor to provide compliance certificate for tests/checks verified by contractor and the same alongwith test certificates to be verified by BHEL



STANDARD CHECK LIST FOR C&I INSTRUMENTS (for Maux Pkgs)

CHECK LIST FOR TRANSMITTER

Sl. No.	Test / Checks	Quantum of check	Reference Doc. / Acceptance Norms	Agency **			Remarks
				M	C	B	
1	CHECKS FOR	SEE NOTE-1 BELOW	APPROVED SPEC./ DATA SHEETS	P	W	V	
	VISUAL.						
	MODEL/TAG No						
2	PROCESS CONNECTION			P	W	V	
3	ACCURACY			P	W	V	
4	REPEATABILITY			P	W	V	
5	HYSTERESIS	P		W	V		
6	EFFECT OF TEMP VARIATION ON ACCURACY	P		W	V		
7	SPAN / ZERO ADJUSTMENT	ONE / TYPE		P	W	V	
8	EFFECT OF SUPPLY VOLTAGE VARIATION			P	W	V	
9	EFFECT OF LOADING (500 OHM METERS)			P	W	V	
10	HIGH PRESSURE TEST	SEE NOTE-1 BELOW		P	W	V	
11	BURN-IN TEST	ONE / TYPE		P	W	V	
12	DEGREE OF PROTECTION		P	W	V		
13	ACCESSORIES AS APPLICABLE	SEE NOTE-1 BELOW	V	V	V		

Legend :

** M = Manufacturer / Sub-contractor, C = Contractor / Nominated Inspecting Agency, B = BHEL, P = Perform, W = Witness, V = Verification

Note :

- Quantum of check shall be as below :
100 % - By Manufacturer
- Manufacturer to maintain calibrated instrument having better accuracy than the item under test. Inspecting engineer shall check the same.
- When material correlation are not available manufacturer's compliance to be provided.
- Contractor to provide compliance certificate for tests/checks verified by contractor and submit the same alongwith test certificates to be verified by BHEL.



STANDARD CHECK LIST FOR C&I INSTRUMENTS (for Maux Pkgs)

CHECK LIST FOR PRESSURE & DP GAUGE

Sl. No.	Test / Checks	Quantum of check	Reference Doc. / Acceptance Norms	Agency **			Remarks	
				M	C	B		
1	CHECK FOR	SEE NOTE-1 BELOW	APPROVED SPEC./ DATA SHEETS	P	W	V		
	SENSOR TYPE							
	DIAL SIZE							
	MODEL NO/TAG NO							
	RANGE/SCALE							
	SWITCH CONTACT RATING & NOS.							
	END CONNECTION							
2	CALIBRATION	ONE	APPROVED SPEC./ DATA SHEETS	P	W	V		
	ACCURACY							
	REPEATABILITY							
	SET POINT ADJUSTMENT							
3	OVER PRESSURE & LEAK TEST			P	W	V		
4	OPERATION OF PRESSURE. RELIEF DEVICE	ONE			P	W	V	
5	REVIEW OF TC FOR	FOR LOT	APPROVED SPEC./ DATA SHEETS	V	V	V		
	MATERIALS OF SENSOR							
	MOVEMENT							
	PROCESS CONNECTION							
6	REVIEW OF TC FOR DEGREE OF PROTECTION	TYPE TEST			V	V	V	
	ACCESSORIES AS APPLICABLE	SEE NOTE-1 BELOW			V	V	V	

Legend :

** M = Manufacturer / Sub-contractor, C = Contractor / Nominated Inspecting Agency, B = BHEL, P = Perform, W = Witness, V = Verification

Note :

- Quantum of check shall be as below :
100 % - By Manufacturer
- Manufacturer to maintain calibrated instrument having better accuracy than the item under test. Inspecting engineer shall check the same.
- Manufacturer to carry out ROUTINE TEST on 100 %.
- When material correlation is not available, MFR's compliance to be provided
- Contractor to provide compliance certificate for tests/checks verified by contractor and submit the same alongwith test certificates to be verified by BHEL.



STANDARD CHECK LIST FOR C&I INSTRUMENTS (for Maux Pkgs)

CHECK LIST FOR LEVEL GAUGE

Sl. No.	Test / Checks	Quantum of check	Reference Doc. / Acceptance Norms	Agency **			Remarks
				M	C	B	
1	CHECK FOR	SEE NOTE-1 BELOW	APPROVED SPEC./ DATA SHEETS / DRWGS	P	W	V	
	TYPE						
	MODEL/ TAG NO.						
	DAIL SIZE						
	RANGE/SCALE						
	END CONNECTION						
2	DIMENSIONS, PROCESS CONNECTION	ONE / LOT		P	W	V	
3	ACCURACY			P	W	V	
4	MATERIAL TC FOR			P	V	V	
	BODY ISO.						
	VALVE						
	GAUGE GLASS						
5	HYD. TEST	SEE NOTE-1 BELOW		P	W	V	
6	ACCESSORIES AS APPLICABLE			P	W	V	

Legend :

** M = Manufacturer / Sub-contractor, C = Contractor / Nominated Inspecting Agency, B = BHEL, P = Perform, W = Witness, V = Verification

Note :

- Quantum of check shall be as below :
100 % - By Manufacturer
- Manufacturer to maintain calibrated instrument having better accuracy than the item under test. Inspecting engineer shall check the same.
- Manufacturer to carry out ROUTINE TEST on 100 %.
- Contractor to provide compliance certificate for tests/checks verifid by contractor and submit the same alongwith test certificates to be verified by BHEL.



STANDARD CHECK LIST FOR C&I INSTRUMENTS (for Maux Pkgs)

CHECK LIST FOR ANNUNCIATORS

Sl. No.	Test / Checks	Quantum of check	Reference Doc. / Acceptance Norms	Agency **			Remarks
				M	C	B	
1	CHECK FOR	SEE NOTE-1 BELOW	APPROVED SPEC./ DATA SHEETS	P	W	V	
	TYPE/ MODEL						
	DIMENSIONS OF HARDWARE						
	MODULARITY						
	SEQUENCE						
	FACIA DETAILS						
2	FUNCTIONAL TEST	100%		P	W	V	
3	IMMUNE TO STEP VARIATIONS IN THE POWER SUPPLY	SEE NOTE-1 BELOW		P	W	V	
4	DEGREE OF PROTECTION FOR ENCLOSURE	TYPE TEST		P	W	V	
5	I/R CHECK	SEE NOTE-1 BELOW		P	W	V	
6	RESPONSE			P	W	V	

Legend :

** M = Manufacturer / Sub-contractor, C = Contractor / Nominated Inspecting Agency, B = BHEL, P = Perform, W = Witness, V = Verification

Note :

- Quantum of check shall be as below :
100 % - By Manufacturer
- Manufacturer to maintain calibrated instrument having better accuracy than the item under test. Inspecting engineer shall check the same.
- Manufacturer to carry out ROUTINE TEST on 100 %.
- Contractor to provide compliance certificate for tests/checks verified by contractor and submit the same alongwith test certificates to be verified by BHEL.

	TITLE: TECHNICAL SPECIFICATION FOR CHLORINATION PLANT 1X800 MW TSGENCO KOTHAGUDEM TPS STAGE -VII, PALONCHA	SPEC NO: PE-TS-410-174-A001	
		VOLUME: II-B	
		SECTION: D	
		REV NO: 00	DATE:

PLC DETAILS



Technical specification for
CONTROL & INSTRUMENTATION

1X800 MW KOTHAGUDEM

SPEC NO.: **PE-TS-410-145-I**

VOLUME

SECTION

REV. NO. 00

DATE : 10.03.2015

SHEET OF

PLC SPECIFICATION

1.00.0 GENERAL

1.01.0 Each of the relevant BOP areas and different auxiliary systems shall be provided with dedicated PLC or proprietary control systems for overall operation and control.

1.01.01 There shall be redundant bidirectional OPC link between DDCMIS network and each Package PLC including PADO for monitoring / performance activities.

1.02.00 These control systems shall conform to high standard of engineering meeting all applicable codes and standard, design and workmanship and shall meet the functional requirements in all respects and shall be capable of performing satisfactorily in continuous commercial operation under the specified environmental condition.

1.03.00 Further this part of the specification details the common technical and functional requirements applicable for all the systems unless specified elsewhere in the specification. Only specific requirements are indicated in this section. However, Bidder shall also adhere to the Section-VI, Subsection A (DDCMIS) of this volume of the specification for other basic and detailed scope & services, philosophy & technical requirements of different hardware and softwares including response time, loading, interface, redundancy criteria, display, logs, spares criteria, drawings and document submission etc.

1.04.00 All local PLCs shall be supplied from one manufacturer for all plants and shall provide single unified hardware and software platform for realizing all the control and monitoring functions.

1.05.00 In general local PLC, Proprietary control system by third party system integrators shall not be allowed and only main PLC/ Proprietary control system manufacturer shall be allowed to do the design engineering, system integration etc. Owner will be the final authority in allowing third party system integrators, if required, for only small applications.

1.06.00 Local control and monitoring facility of the equipments from the respective package control room and local panels is required.

1.06.01 The redundant upper level network of each Package PLC system will be connected to redundant server to be located in Plant Engineer's room. Suitable Fibre optic cable shall be used for redundant interconnections.

1.06.02 The hot redundant Server shall continuously update all the inputs. The switchover to the hot standby Server shall be smooth and bumpless with proper indication to the operator.

1.06.03 Local PLC Workstations shall be capable of programming activities for control systems of the package including set point change, logic build up & modifications, graphics build up & modifications etc.

1.06.04 Programming shall not require special computer skills. On the programming console, it shall be possible to do the programming, self-diagnostics, testing of sequence, simulation and any sequence modification.

1.06.05 Alarm monitoring / reporting, generation of logs, trends, calculations, printing of logs & reports etc. shall be available in local workstations as well as in remote DDCMIS network workstations. In case of failure of DDCMIS network, control and monitoring of the individual packages shall still be possible from the Operator Work Stations in the respective package control room.

1.06.06 The system shall permit carrying out of the on-line dynamic test and self-diagnostic checks while maintaining safe condition and without endangering the safety of equipment without having any influence on the process being controlled.

2.00.00 GENERAL TECHNICAL REQUIREMENTS

2.01.00 Bidders scope of supply shall include , but not limited to , Hot standby local PLC / Proprietary control & monitoring system for each of BOP areas and shall consist of IO cards, remote and Local IO rack, control rack, redundant Power supply modules, redundant communication / networking and interconnection Cables, redundant processor and communication cards, redundant Servers, operator work stations / GUI, LVS(if applicable) , printer, redundant networking hardware etc. , system cabinets ,startup, commissioning, mandatory and recommended spares, drawing, documents and training to owner's personnel at site and at vendors works etc.

2.02.00 All types of programming packages shall be licensed with facility of editing and configuration. For each of the PLC / proprietary control system, the programming software shall be supplied in a laptop for each package preloaded with package in addition to other types of devices such as CD, DAT etc.

2.03.00 In addition to the Operator and/ cum Engineering workstations, Bidder shall also supply LCD screen based display unit, control switches and other operational keys (GUI). Bidder shall also provide minimum of one no. laptop computer for each PLC based package and with latest hardware configuration and loaded with suitable operating, application program including licensed softwares as a backup engineering cum programming and configuration station. **This loaded laptop shall be handed over by Bidder well in advance of FAT to Owner's head office at Hyderabad.**

2.04.00 The System shall allow dependable and effective control of the process equipment and shall be designed for maximum integrity and reliability. Integrity shall be maintained by providing a dual hot redundant system .The System shall have a capability to monitor and take actions for distributed functions from a central location.

2.05.00 The control & Instrumentation shall be through dedicated microprocessor based PLC, Common DDCMIS network, proprietary system for the each of the respective plants covering the total functional requirement of sequence control, regulatory control, interlock & protection, monitoring, alarm, data logging.

2.06.00 The loop cycle time shall be less than 1 sec for close loops and open loops. The switchover from main controller to redundant controller shall be bump less; and shall be within one cycle time i.e. within 50 msec.

2.07.00 Each controller shall have 40% functional capacity to implement additional functional blocks over and above implemented logic / loops under worst loading conditions.

2.08.00 Field Input/Outputs

The System shall meet the following I/O card requirements. The maximum number of inputs / outputs to be connected to each type of module shall be as follows:

a)	Analog input module	8
b).	Analog output module	8
c)	Binary input module	16
d)	Binary output module	16

2.09.00 Communications System

2.09.01 The Bidder shall include a dual hot redundant communication system

2.09.02 The data highway speed shall be 100 Mbps.

2.10.00 Operator Interface

Operator Work Station (OWS) / GUI / LVS shall perform control monitoring and operation of all auxiliaries/ drives. However, Push button stations are also to be provided with RIOs.

2.11.00 Interface with Common DDCMIS system

Each PLC, proprietary control systems shall be interfaced to Common DDC MIS network with bidirectional OPC link. The link shall be redundant.

2.12.00 PLC shall be of latest version and all the modules like Control modules, communication modules, IO modules, and network interface modules etc., modules shall be from the same family of hardwares and softwares and shall be sourced from Bidder's Original Principal's works.

2.13.00 PLC shall have also, but not limited to, the following requirements,

2.13.01 I/O LAN Speed shall be minimum 5 Mbps - 100 MBPS on Deterministic LAN.

2.13.02 I/Os shall be Rack based and not Din Rail Mountable.

2.13.03 Processors and I/Os shall be of same family.

2.13.04 Diagnostics for DI/DO, AI & AO shall be provided.

2.13.05 All PLC I/O Rack Power Supplies shall be redundant. Only Bulk power supply redundancy will not be acceptable.

2.13.06 Processor selection shall be such that it shall never be loaded more than 50% at any time during the operation.

2.13.07 SOE module (if applicable) must stamp and store 250+ events at card level.

2.13.08 PLC shall store tag details and bit word addresses on upload of logic as well as tag descriptions.

2.13.09 Remote I/O Rack outside control room shall be on Fiber Optic communication only.

2.13.10 Processor shall be self learning in case of failure. No need to configure and program replaced processor.

2.14.00 Operating work stations must be Run time license/servers. Client server architecture not acceptable.

2.15.00 Each operator work station must have minimum 150% tags handling capability.

2.16.00 Auto Tuning feature of PIDs at PLC controller level shall be available.

2.17.00 Programming facility shall be available from Remote IO stations.

2.18.00 Processor shall support minimum twice the overall system IO handling capacity in Redundant configuration.

2.19.00 Online editing of Program shall be possible.

2.20.00 Processors shall be Hot back up.

2.21.00 Automatic synchronization of primary processor/controller of PLC with secondary processor/controller.

2.22.00 Bumpless switchover to secondary processor/controller of PLC when the primary fails.

2.23.00 Power supply module redundancy shall be true power supply redundancy

2.24.00 Automatic program and data equalization of primary processor/controller of PLC.

2.25.00 Automatic 'Forcing Bit' update in the secondary processor/controller of PLC when any Forcing is applied in the primary processor/controller of PLC. (Forcing Bit Table of both the PLCs must be automatically synchronised.)

2.26.00 Softwares

The latest version of all necessary applications and networking software shall be supplied for the system. The software tool shall have facility to interface with third party software packages. Window base operating system shall be provided. The system shall be OPC compliant. Easy upgradation and future expansion facility shall be available.

All softwares used shall be licensed versions only. All software user licenses shall be valid for entire life of power plant. User shall not have to pay any recurring license fee during the usage period of the system.

It shall be possible to upgrade the installed system with the latest available version of the software model during the plant life.

2.23.00 Redundant Uninterrupted Power Supplies (UPS) shall be provided for each Local PLC.. UPS specification shall be as per requirements indicated in Section V of this specification.

	TITLE: TECHNICAL SPECIFICATION FOR CHLORINATION PLANT 1X800 MW TSGENCO KOTHAGUDEM TPS STAGE -VII, PALONCHA	SPEC NO: PE-TS-410-174-A001	
		VOLUME: II-B	
		SECTION: D	
		REV NO: 00	DATE:

PLC DATA SHEET

	DATA SHEET FOR PLC SYSTEM		SPECIFICATION NO.: PE-TS-410-	
			VOLUME II B	
			SECTION D	
			REV. NO. 00	DATE: 04.03.2015
			SHEET 1 OF	1
Data Sheet No.:				
Data Sheet A&B				
DATA SHEET – A FOR PLC SYSTEM (TO BE FILLED BY PURCHASER)			DATA SHEET – B FOR PLC SYSTEM (TO BE FILLED BY BIDDER)	
GENERAL	PROJECT	1X800MW KOTHAGUDEM TPS		
	SERVICE			
	QUANTITY	<input type="checkbox"/> UNITISED <input checked="" type="checkbox"/> COMMON		
	LOCATION	<input checked="" type="checkbox"/> INDOOR <input type="checkbox"/> OUTDOOR <input checked="" type="checkbox"/> AC <input type="checkbox"/> NON-AC*		
PLC EQUIPMENT	MAKE / MODEL NO.	BIDDER TO INDICATE		
	PROCESSOR	REDUNDANT WITH HOT STANDBY		
	DATA BUS (HMI)	<input type="checkbox"/> COPPER WIRE <input type="checkbox"/> FIBRE OPTIC		
	DATA BUS (I/O - CPU)	<input type="checkbox"/> COPPER WIRE <input type="checkbox"/> FIBRE OPTIC		
	DATA BUS (REMOTE I/O - CPU)	<input type="checkbox"/> COPPER WIRE <input type="checkbox"/> FIBRE OPTIC		
	FIELD CONTACTS INTERROGATION VOLTAGE	<input checked="" type="checkbox"/> 24 V DC <input type="checkbox"/> 48 V DC <input type="checkbox"/> 110 V AC		
	LOCATION OF COUPLING RELAYS	<input type="checkbox"/> MCC <input checked="" type="checkbox"/> PLC PANEL		
	DESKTOP OWS QUANTITY	<input type="checkbox"/> ONE <input type="checkbox"/> TWO <input type="checkbox"/> _____ <input checked="" type="checkbox"/> DESKTOP VERSION <input type="checkbox"/> SERVER VERSION <input type="checkbox"/> WORK STATION VERSION REQUIREMENT OF OWS IN CCR <input type="checkbox"/> YES <input type="checkbox"/> NO QUANTITY _____		
	DESKTOP MONITOR TYPE	<input type="checkbox"/> 19" <input checked="" type="checkbox"/> 24" TFT/CRT MONITOR <input type="checkbox"/> GIU <input type="checkbox"/> OTHERS		
	PRINTER	INKJET <input type="checkbox"/> A3 ___NOS <input type="checkbox"/> A4 ___NOS LASER B/W <input type="checkbox"/> A3 ___NOS <input type="checkbox"/> A4 ___NOS COLOR INKJET <input type="checkbox"/> A3 ___NOS <input type="checkbox"/> A4 ___NOS COLOR LASER <input checked="" type="checkbox"/> A3_1_NOS <input type="checkbox"/> A4 ___NOS		
	PROGRAMMING / CONFIGURATION FACILITY	A) <input type="checkbox"/> HAND HELD <input checked="" type="checkbox"/> LAPTOP B) ENGINEERING SOFTWARE <input type="checkbox"/> ONE OWS <input type="checkbox"/> ALL OWS <input type="checkbox"/> LAPTOP		
SAFETY STANDARD	<input type="checkbox"/> SIL-3 <input type="checkbox"/> SIL-2 <input checked="" type="checkbox"/> NIL			
SPARE LIST	COMPUTER FURNITURE	BOQ <input checked="" type="checkbox"/> YES <input type="checkbox"/> NO INDUSTRIAL GRADE <input checked="" type="checkbox"/> YES <input type="checkbox"/> NO <input type="checkbox"/> START UP & COMMISSIONING <input checked="" type="checkbox"/> MANDATORY SPARE <input type="checkbox"/> RECOMMENDED		
	SPARE LIST			
	SPARE LIST ATTACHED	<input checked="" type="checkbox"/> YES <input type="checkbox"/> NO		
REDUNDANCY	CPU	<input checked="" type="checkbox"/> YES <input type="checkbox"/> NO		
	POWER SUPPLY	<input checked="" type="checkbox"/> YES <input type="checkbox"/> NO		
	COMMUNICATION	<input checked="" type="checkbox"/> YES <input type="checkbox"/> NO		
	I/O CARD	<input type="checkbox"/> YES <input type="checkbox"/> NO		
	OTHER ELECTRONICS	<input type="checkbox"/> YES <input type="checkbox"/> NO		
				As per vendor practice

	DATA SHEET FOR PLC SYSTEM		SPECIFICATION NO.: PE-TS-410-	
			VOLUME II B	
			SECTION D	
			REV. NO. 00	DATE: 04.03.2015
			SHEET 1 OF	1
Data Sheet No.:				
Data Sheet A&B				
DATA SHEET – A FOR PLC SYSTEM (TO BE FILLED BY PURCHASER)			DATA SHEET – B FOR PLC SYSTEM (TO BE FILLED BY BIDDER)	
No. of CHANNELS PER CARD	ANALOG INPUT	<input checked="" type="checkbox"/> 8 NOs <input type="checkbox"/> 16 NOs		
	ANALOG OUTPUT	<input checked="" type="checkbox"/> 8 NOs <input type="checkbox"/> 16 NOs		
	BINARY INPUT	<input checked="" type="checkbox"/> 16 NOs <input type="checkbox"/> 32 NOs		
	BINARY OUTPUT	<input checked="" type="checkbox"/> 16 NOs <input type="checkbox"/> 32 NOs		
	RTD** 4	NOs		
	THERMOCOUPLE** 8	NOs		
	ELECTRONIC CARD ISOLATION	<input type="checkbox"/> GALVANIC <input type="checkbox"/> OPTICAL <input type="checkbox"/> OTHER		
PANEL	QUANTITY BI	DDER TO INDICATE		
	CLASS OF PROTECTION(Refer Location of PLC)	<input checked="" type="checkbox"/> IP-42		
	REMOTE I/O PANEL	<input checked="" type="checkbox"/> YES <input type="checkbox"/> NO AC REQUIREMENT <input checked="" type="checkbox"/> YES <input type="checkbox"/> NO		
	COLOUR# RAL	7032		
	BACK-UP DESK	<input type="checkbox"/> YES <input checked="" type="checkbox"/> NO		
	MIMIC	<input type="checkbox"/> YES <input checked="" type="checkbox"/> NO IF YES, THEN <input type="checkbox"/> PANEL MOUNTED GUI <input type="checkbox"/> ACRYLIC		
	CONTROL HARDWARE	<input type="checkbox"/> PB <input type="checkbox"/> INDICATORS <input checked="" type="checkbox"/> FACIAS 25 Nos. <input type="checkbox"/> OTHERS		
CONFORMAL COATING	<input type="checkbox"/> YES <input checked="" type="checkbox"/> NO			
COMMUNICATION WITH OTHER SYSTEM	HARDWIRED	<input checked="" type="checkbox"/> YES <input type="checkbox"/> NO		
	PURPOSE	<input type="checkbox"/> CONTROL <input checked="" type="checkbox"/> MONITORING		
	MEDIUM	<input type="checkbox"/> UTP <input checked="" type="checkbox"/> FIBRE OPTIC <input type="checkbox"/> OTHERS		
	TIME SYNCHRONIZATION SIGNAL FORMAT	<input type="checkbox"/> PULSE <input type="checkbox"/> RS-485 <input checked="" type="checkbox"/> IRIG-B <input type="checkbox"/> NTP		
	SOFTLINK	<input type="checkbox"/> MODBUS <input checked="" type="checkbox"/> OPC IF MODBUS THEN <input type="checkbox"/> RS-485 <input type="checkbox"/> ETHERNET		
	SERIAL LINK	COMMUNICATION PORT TYPE _____		
POWER SUPPLY INPUT FEEDER	PLC PANEL	BIDDER TO INDICATE LOAD DATA		
	REMOTE I/O PANEL	BIDDER TO INDICATE LOAD DATA		
POWER SUPPLY	SOURCE \$\$	<input checked="" type="checkbox"/> UPS(INDUSTRIAL GRADE) <input type="checkbox"/> 24V DC CHARGER		
	BATTERY TYPE	<input type="checkbox"/> Ni-Cd <input checked="" type="checkbox"/> LEAD ACID <input type="checkbox"/> OTHERS		
	BACK-UP TIME	<input type="checkbox"/> 30 MINS <input checked="" type="checkbox"/> 60 MINS <input type="checkbox"/> OTHERS		
	BATTERY CONFIGURATION	<input type="checkbox"/> 1X100% <input checked="" type="checkbox"/> 2X100% <input type="checkbox"/> 2X50%		As per MAX philosophy
CUSTOMER TRAINING	TRAINING	<input checked="" type="checkbox"/> REQUIRED <input type="checkbox"/> NOT REQUIRED		
	NO OF DAYS	3 DAYS		
	LOCATION	<input type="checkbox"/> VENDOR'S WORK <input type="checkbox"/> PROJECT SITE <input type="checkbox"/> OTHERS		

*IF THE LOCATION IS INDOOR,KINDLY SPECIFY IF PLC PANEL IS PLACED IN AC OR NON-AC ENVIRONMENT.

**SHALL NOT BE APPLICABLE IF TEMPERATURE TRANSMITTERS ARE ENVISAGED.

PROJECT SPECIFIC PAINT SHADES, IF APPLICABLE TO BE USED.

\$\$ CHECK & REPLACE WITH MAIN UPS SLD IF POWER SUPPLY IS NOT APPROVED BY CUSTOMER.

	TITLE: TECHNICAL SPECIFICATION FOR CHLORINATION PLANT 1X800 MW TSGENCO KOTHAGUDEM TPS STAGE -VII, PALONCHA	SPEC NO: PE-TS-410-174-A001	
		VOLUME: II-B	
		SECTION: D	
		REV NO: 00	DATE:

PLC CONFIGURATION DIAGRAM

NOTES:

- 1) TABLE TOP OWS/EWS SHALL BE 24" OR AVAILABLE INDUSTRY STANDARD.
- 2) PLC SYSTEM SHALL HAVE REDUNDANCY IN PROCESSOR, POWER SUPPLY AND COMMUNICATION SYSTEM.
- 3) UPS POWER SUPPLY SHALL BE USED FOR PLC PANEL(S), OWS/EWS AND NETWORK COMPONENTS.
- 4) POWER SUPPLY ARRANGEMENT FOR PLC SYSTEM SHALL BE AS SHOWN ON SHEET 2 OF 2.
- 5) PLC PANEL SHALL HAVE PROVISION TO ACCEPT TIME SYNC. SIGNAL (NTP/IRIG-B) FROM MASTER CLOCK SYSTEM (BHEL SUPPLY).
- 6) PLC PANEL SHALL HAVE PROVISION FOR DATA EXCHANGE (OPC) WITH PLANT DCS.
- 7) NECESSARY PATCH CORD/CONVERTERS, LIU AT BOTH PLC AND DCS END SHALL BE IN BHEL-EDN SCOPE.

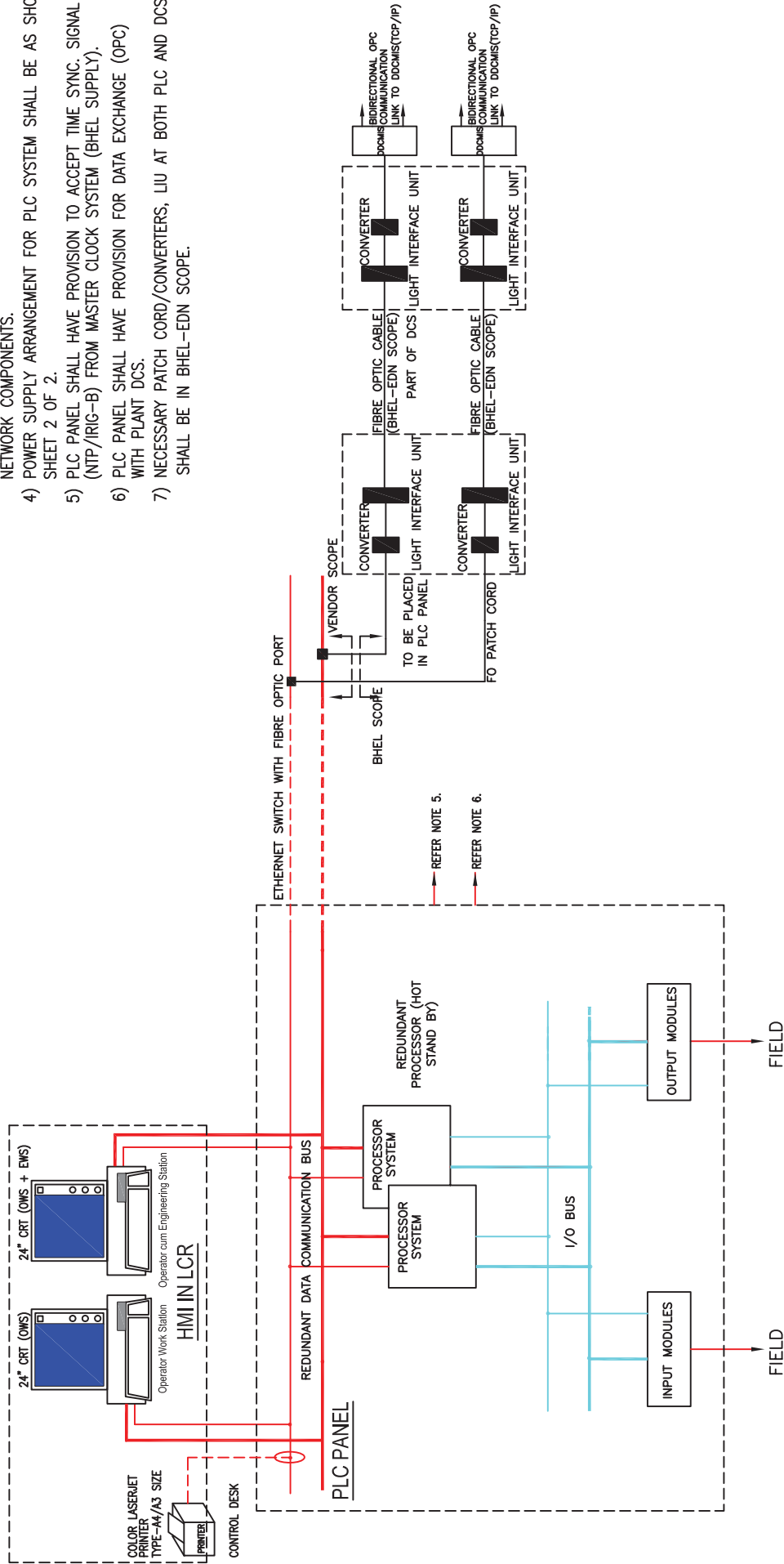

LEGEND: -

- PLC - PROGRAMMABLE LOGIC CONTROLLER
- DCS - DISTRIBUTED CONTROL SYSTEM
- UPS - UNINTERRUPTED POWER SUPPLY
- OWS/EWS - OPERATOR WORK STATION/ ENGINEERING WORK STATION
- HMI - HUMAN MACHINE INTERFACE
- NTP - NETWORK TIME PROTOCOL
- OPC - OLE PROCESS CONTROL
- MCCB - MOULDED CASE CIRCUIT BREAKER
- LCR - LOCAL CONTROL ROOM
- CCR - COMMON CONTROL ROOM

 BHEL Maharashtra Company	PROJECT: 1X800 KOTHAGUDEM TPS STAGE-VII, UNIT-12	DRG.NO. PE-DM-410-145-1900
	TITLE: PLC CONFIGURATION CW CHLORINATION	DATE: 23.02.2015
		REV.NO. 00
		SHT 7 OF 11

THIS DOCUMENT IS PART OF PE-ITS-410-174-A001

	TITLE: TECHNICAL SPECIFICATION FOR CHLORINATION PLANT 1X800 MW TSGENCO KOTHAGUDEM TPS STAGE -VII, PALONCHA	SPEC NO: PE-TS-410-174-A001	
		VOLUME: II-B	
		SECTION: D	
		REV NO: 00	DATE:

PLC QAP AND FAT



Technical specification for
CONTROL & INSTRUMENTATION

1X800 MW KOTHAGUDEM

SPEC NO.: **PE-TS-410-145-I**

VOLUME

SECTION

REV. NO. 00

DATE : 10.03.2015

SHEET OF

PLC Quality Plan



STANDARD QUALITY PLAN FOR PROGRAMMABLE LOGIC CONTROLLER

QUALITY PLAN NO.: PE-QP-999-145-1036

VOLUME IIB

SECTION D

REV. NO. 01 DATE: 24.08.2007

SHEET 1 OF 8

Sl. No.	Component / operation	Characteristics Checked	* Category	Type/Method of Check	Extent of Check	Reference documents	Acceptance Norms	Format of Records	Agency \$			Remarks
									P	W	V	
1.0	Materials /Components											
1.1	Panels & Control Desks	Physical Inspection for Dimensions, Painting, Cutouts, Lifting / Locking Arrangements, Components, Drawing Pocket, Mounting accessories, Plinth & AV Pads, Cable Gland Plates, Hardwares, Hinges, Louvers & Filters, Fans & Panel Lamps	MA Visua	I	100%	Contract specifications, Approved GA Drawings, BOQ	As per ref documents. No physical damage.	BHEL Quality Inspection Report.	3/2 2	1		
1.2	Power Supply/Packs, Battery charger, Transformer, UPS.	Physical Inspection Physical Damages Dimensions Mounting Accessories	MA Visua	I	100%	Contract specifications, BOQ.	As per reference documents, Test Report	BHEL Quality Inspection Report.	3/2 2	1		
1.3	Indicating Lamp, Annunciator, Meters, Transducers, Signal Converters, Instruments, Single Loop Controllers	Physical Verification Physical Damages Dimensions Accessories	MA Visua	I	100%	Contract specifications, BOQ.	As per ref documents No physical damage. Test/ Calibration report.	BHEL Quality Inspection Report	3/2 2	1		
1.4	PLC processors, I/O modules, Power Supply modules, Communication modules, Mounting Racks, Ethernet	Physical Inspection <ul style="list-style-type: none"> • Identification Labels • Physical Damages • Quantity • Spare Capacity 	MA Visua	I	100%	Product Catalogue, Data sheets, Approved Configuration diagram, BOQ	As per ref documents. Test Certificates	BHEL Quality Inspection Report.	3/2 2	1		

LEGEND: * CR - Critical characteristics
 MA - Major characteristics
 MI - Minor characteristics

\$ P - Agency Performing the Test.
 W - Agency Witnessing the Test.
 V - Agency Verifying the Test.

1 - BHEL
 2 - Vendor
 3 - Sub-vendor

THIS DOCUMENT IS PART OF PE-TS-410-174-A001



PEM :: C&I

STANDARD QUALITY PLAN FOR PROGRAMMABLE LOGIC CONTROLLER

QUALITY PLAN NO.: PE-QP-999-145-1036
 VOLUME IIB
 SECTION D
 REV. NO. 01 DATE: 24.08.2007
 SHEET 2 OF 8

Sl. No.	Component / operation	Characteristics Checked	* Category	Type/Method of Check	Extent of Check	Reference documents	Acceptance Norms	Format of Records	Agency \$			Remarks
									P	W	V	
1.5	CPU, Monitor, Keyboard, Mouse, CD Drives, Printers, OS, System Software, Engineering software in the form of Licensed CD.	Physical Inspection Identification Labels, Tech. Specification Physical Damages Accessories Installation arrangements for Computers & Printers	MA	Visual	100%	Contract specifications, Product Catalogue, Approved GA / Configuration drawing, BOQ.	As per reference documents.	BHEL Quality Inspection Report.	3/2 2		1	

LEGEND: * CR - Critical characteristics
 MA - Major characteristics
 MI - Minor characteristics

\$ P - Agency Performing the Test.
 W - Agency Witnessing the Test.
 V - Agency Verifying the Test.

1 - BHEL
 2 - Vendor
 3 - Sub-vendor

THIS DOCUMENT IS PART OF PE-TS-410-174-A001



PEM :: C&I

STANDARD QUALITY PLAN FOR PROGRAMMABLE LOGIC CONTROLLER

QUALITY PLAN NO.: **PE-QP-999-145-1036**
 VOLUME IIB
 SECTION D
 REV. NO. **01** DATE: 24.08.2007
 SHEET 3 OF 8

Sl. No.	Component / operation	Characteristics Checked	* Category	Type/Method of Check	Extent of Check	Reference documents	Acceptance Norms	Format of Records	Agency \$			Remarks
									P	W	V	

2.0 Assembly												
2.1	Functional Test for HMI/OVS devices such as Monitors, Keyboards, Mouse, Printers etc.	Operation	MA	Functional	100%	Approved Configuration Diagram & BOQ and FAT	Correct Operation of interconnected Devices of HMI system.	BHEL Quality Inspection Report.	2 1	1		
2.2	Hardware Functional Verification.	Physical arrangement, Wiring check & labeling, Continuity Checking, IR & HV test	MA	Visual/ Electrical	100%	Approved GA Drawing, Panel Wiring Diagram, IR & HV as per relevant International standard	Test Certification	BHEL Quality Inspection Report.	2 2	1		
2.3 Powering Up		Healthiness of all the modules/equipment, associated with Powering of PLC system	MA	Visual /Electrical	100%	Approved power supply scheme	All equipment to be healthy on power ON	BHEL Quality Inspection Report.	2 1	1		
2.4 Burn in test for PLC modules		Healthiness of PLC modules on Continuous Energisation, Temperature maintenance	MA	Visual/ Electrical	100% F	AT Procedure	Test certification as per FAT	BHEL Quality Inspection Report.	2 2	1		

LEGEND: * CR - Critical characteristics
 MA - Major characteristics
 MI - Minor characteristics

\$ P - Agency Performing the Test.
 W - Agency Witnessing the Test.
 V - Agency Verifying the Test.

1 - BHEL
 2 - Vendor
 3 - Sub-vendor

THIS DOCUMENT IS PART OF PE-TS-410-174-A001



PEM :: C&I

STANDARD QUALITY PLAN FOR PROGRAMMABLE LOGIC CONTROLLER

QUALITY PLAN NO.: PE-QP-999-145-1036

VOLUME IIB

SECTION D

REV. NO. 01 DATE: 24.08.2007

SHEET 4 OF 8

Sl. No.	Component / operation	Characteristics Checked	* Category	Type/Method of Check	Extent of Check	Reference documents	Acceptance Norms	Format of Records	Agency \$			Remarks
									P	W	V	

3.0	Factory Acceptance Test (FAT)											
3.1	Input Output Functional Verification	I/O configuration, I/O operation	MA	Visual/Electrical	100%	FAT Procedure	AS per FAT	BHEL Quality Inspection Report.	2 1			1
3.2	Processor Verification	Processor configuration, Powering up, standby operation (as applicable) and Loading	MA	Visual	100%	FAT Procedure	AS per FAT	BHEL Quality Inspection Report.	2 1			1
3.3	Power Supply Module Verification	Redundancy Operation	MA	Electrical	100%	FAT Procedure	AS per FAT	BHEL Quality Inspection Report.	2 1			1
3.4	Communication System Verification	Redundancy operation of Communication System, Measurement of Response Time, Communication with third party system	MA	Electrical	100%	FAT Procedure	AS per FAT	BHEL Quality Inspection Report.	2 1			1
3.5	Diagnostic Verification	Self Diagnostic features of PLC system	MA	Visual	100%	FAT Procedure	AS per FAT	BHEL Quality Inspection Report.	2 1			1
3.6	Control Panel/Desk Verification	Operation of PLC driven annunciation system, Mosaic, Push buttons & selector switches, Indicating lamps	MA	Visual	100%	FAT Procedure	AS per FAT	BHEL Quality Inspection Report.	2 1			1
3.7	Software Verification	(i) Control Logics (ii) Engineering Features (iii) HMI Features	MA	Visual	100%	FAT Procedure	AS per FAT	BHEL Quality Inspection Report.	2 1			1

LEGEND: * CR - Critical characteristics
MA - Major characteristics
MI - Minor characteristics

\$ P - Agency Performing the Test.
W - Agency Witnessing the Test.
V - Agency Verifying the Test.

1 - BHEL
2 - Vendor
3 - Sub-vendor

THIS DOCUMENT IS PART OF PE-TS-410-174-A001

**STANDARD QUALITY PLAN
FOR
PROGRAMMABLE LOGIC CONTROLLER**

QUALITY PLAN NO.: PE-QP-999-145-1036__		
VOLUME IIB		
SECTION D		
REV. NO. 01	DATE: 24.08.2007	
SHEET 5	OF	8

FACTORY ACCEPTANCE TEST (FAT) PROCEDURE

This document covers procedure to conduct/witness PLC system functional tests in order to demonstrate conformity to purchase specifications and related engineering documents. The test shall be conducted at the system suppliers works. The system supplier shall conduct all functional tests before commencing FAT and test results shall be made available during FAT. Vendor must furnish following relevant drawings, duly approved by BHEL Engineering, for reference during FAT.

- a) Technical Specification of PLC.
- b) PLC System Configuration
- c) General Assembly Drawings.
- d) Panel Wiring Diagrams.
- e) Bill of Quantity for PLC System.
- f) Logic Diagram.
- g) HMI Schematics.
- h) Input / Output List.

Further the vendor shall furnish applicable product specification, datasheets, catalogues, test-certificates, and internal inspection records to enable FAT. Vendor shall also submit, [to the inspecting agency](#), his standard test procedure, for clauses given below; where vendor's standard practice has been referred.

APPLICABLE TEST PROCEDURE:

1. Input/Output Functional Verification.

Check for correctness of addressing of racks, slots and I/O modules as per applicable PLC configuration diagram. Appropriate signal generators shall be used to simulate Inputs and outputs to check operation and SCAN time. [Check online replacement of cards, processors, power supply etc.](#)

2. Processor Verification

PLC Configuration drawing to be referred for ascertaining

- i) Redundancy

**STANDARD QUALITY PLAN
FOR
PROGRAMMABLE LOGIC CONTROLLER**

QUALITY PLAN NO.: PE-QP-999-145-I036__		
VOLUME IIB		
SECTION D		
REV. NO. 00	DATE: 23.03.2005	
SHEET 6	OF	8

ii) Type (Hot or Cold)

Both the processors are to be checked for healthiness in case of redundant configuration as per vendor's standard practice. In case of hot redundancy, switchover of control from primary processor to standby processor shall be demonstrated for uninterrupted control and data processing as per vendor's standard practice. Switchover shall be witnessed, by manual power off or resetting the Primary CPU or simulating failure of primary processor. Checking should be by witnessing the lighting up of Processor's LEDs as per manufacturer's product standard.

Vendor shall demonstrate, as per Vendor's standard practice, adequate Loading (Spare Capacity) of Processors, as mentioned in contract specs. This shall be done, by simulating worst load operation of fully integrated PLC system.

3. Power Supply Module Verification

Check if PSM is in redundant mode as per specification. Check the healthiness of power supply from both the modules 'lamp indication/measurement. Simulate failure of one PSM and verify that standby PSM has taken over without any interruption.

4. Communication System Verification

Communication system has to be in line with approved PLC Configuration Diagram. Verify that both the communication buses are intact and connected. Communication between PLC processors, I/O rack, OWS etc. is to be checked through simulation of input data. Simulate the bus failure by disconnection of working bus. Check that the communication continues without interruption or loss of data.

Following response times are to be demonstrated as per vendor's standard practice for conformance to contract specifications:

1. Screen update time
2. I/O scan time
3. SOE resolution time
4. Data transfer time with third party system using Communication Protocol as per Contract specification and as per quantum of data as per approved signal exchange list.

5. Diagnostic Verification

Product Catalogue/Literature shall be referred for checking of all diagnostic features. Hardware failure to be simulated by removing an I/O

**STANDARD QUALITY PLAN
FOR
PROGRAMMABLE LOGIC CONTROLLER**

QUALITY PLAN NO.: PE-QP-999-145-I036 ___		
VOLUME IIB		
SECTION D		
REV. NO. 00	DATE: 23.03.2005	
SHEET 7	OF	8

6. Control Panel /Desk Verification

- i) PLC driven annunciation system should be checked by alarm signal simulation.
- ii) Push Button and selector switch operation should be checked by verification of corresponding change of status of Data Base point.
- iii) Indicating lamp / MIMIC should be checked by corresponding Data Base point simulation.

7. Software Verification

- i). Control Logics:- Software switches, lamps and Analog sources shall be used for simulation of field conditions .Control logics shall be checked for its correct functionality as per approved logic schemes
- ii). Engineering features:-
 - a) Online changing of parameters, set points.
 - b) Online modification in Control Logic Diagrams.
 - c) Online configuration of Graphics, Trends, Logs, HSR.
- iii). HMI features:-
Check for configuration & operation of Graphics, Trends, Logs, HSR and Alarms, in the form of Displays and Printouts, by simulation of Inputs as per approved documents.

8. Burn in Elevated Temperature test

Electronic equipments shall be subjected to Burn in elevated temperature test as per the procedure detailed below:

- a) (i) PLC modules are kept at 50 Deg c under continuous energized condition for 48 hours.

**STANDARD QUALITY PLAN
FOR
PROGRAMMABLE LOGIC CONTROLLER**

QUALITY PLAN NO.: PE-QP-999-145-1036		
VOLUME IIB		
SECTION D		
REV. NO. 00	DATE:	
23.03.2005		
SHEET 8	OF	8

ii) 48 hours test period shall be divided into 4 equal time segments of 12 hours duration each. For every 12 hours duration segment, after lapse of first 11 hours 110% of nominal voltage shall be applied to the panel under test for a period of 30 minutes followed by application of 90% of nominal voltage for the next 30 minutes.

b) Assembled Panels with complete wiring shall be kept under continuous energized condition for 120 hours at ambient temperature. Temperature rise in panels should be below 10 Deg C above ambient.

	TITLE: TECHNICAL SPECIFICATION FOR CHLORINATION PLANT 1X800 MW TSGENCO KOTHAGUDEM TPS STAGE -VII, PALONCHA	SPEC NO: PE-TS-410-174-A001	
		VOLUME: II-B	
		SECTION: D	
		REV NO: 00	DATE:

DETAILS FOR COMPUTER AND FURNITURE



Technical specification for
CONTROL & INSTRUMENTATION

1X800 MW KOTHAGUDEM

SPEC NO.: **PE-TS-410-145-I**

VOLUME

SECTION

REV. NO. 00

DATE : 10.03.2015

SHEET OF

PC SPECIFICATION

	Technical specification for Computer For 1X800 MW Kothagudem	SPEC NO.: PE-TS-410-145-I	
		VOLUME	
		SECTION	
		REV. NO. 00	DATE : 07.03.2015
		SHEET	OF

SPECIFICATION FOR PC

a. CPU

1. Processor : Intel core i5 or better, 32 bit
2. RAM : 4 GB min. and expandable to 16 GB
3. Hard Drive : 500 GB or more
4. Removable bulk storage : DVD (R/RW)
5. Graphic accelerator : 8MB (minm.)
6. Graphic Memory : dedicated 1GB or better
7. Operating System : Windows 7 or better
8. Audio controller : 16 bit
9. Communication Port : 2 serial, one parallel, 8 USB, Dual 100Mbps Ethernet
10. Expansion Slot : 3
11. Cache : 512 KB Level 2
12. Video Card : PCI

b. MONITOR

1. Type : LCD COLOUR MONITOR
2. Screen Diagonal : 24" (approx.) flat
3. Display : XGA or better
4. Resolution : 1024 by 768 or better
5. Degree of Protection : IP-30
6. External Controls : Brightness, contrast, Horizontal/Vertical, amplification & Shift
7. Version : To suit Industrial application



Technical specification for
CONTROL & INSTRUMENTATION

1X800 MW KOTHAGUDEM

SPEC NO.: **PE-TS-410-145-I**

VOLUME

SECTION

REV. NO. 00

DATE : 10.03.2015

SHEET OF

FURNITURE SPECIFICATION



Technical specification for
FURNITURE
 For
 1X800 MW Kothagudem

SPEC NO.: **PE-TS-410-145-I**

VOLUME

SECTION

REV. NO.

00

DATE : 07.03.2015

SHEET

OF

SPECIFICATION FOR FURNITURE

- a) 4 Nos. cushioned revolving, independently adjustable seat and back chairs.
- b) Glass top Teak wood / MDF table for mounting Operator Station monitors.
- c) Printer tables.
- d) Glass top Teak wood / MDT table for System Engineering Room / Engineering stations with drawer at end.
- e) Glass top teak wood / MDF table with vertical file mounting arrangement (two layer to house approx. 40 Nos of files and lockable drawers at both end) for System Engineering Room / Engineers.

	TITLE: TECHNICAL SPECIFICATION FOR CHLORINATION PLANT 1X800 MW TSGENCO KOTHAGUDEM TPS STAGE -VII, PALONCHA	SPEC NO: PE-TS-410-174-A001	
		VOLUME: II-B	
		SECTION: D	
		REV NO: 00	DATE:

UPS SCHEME

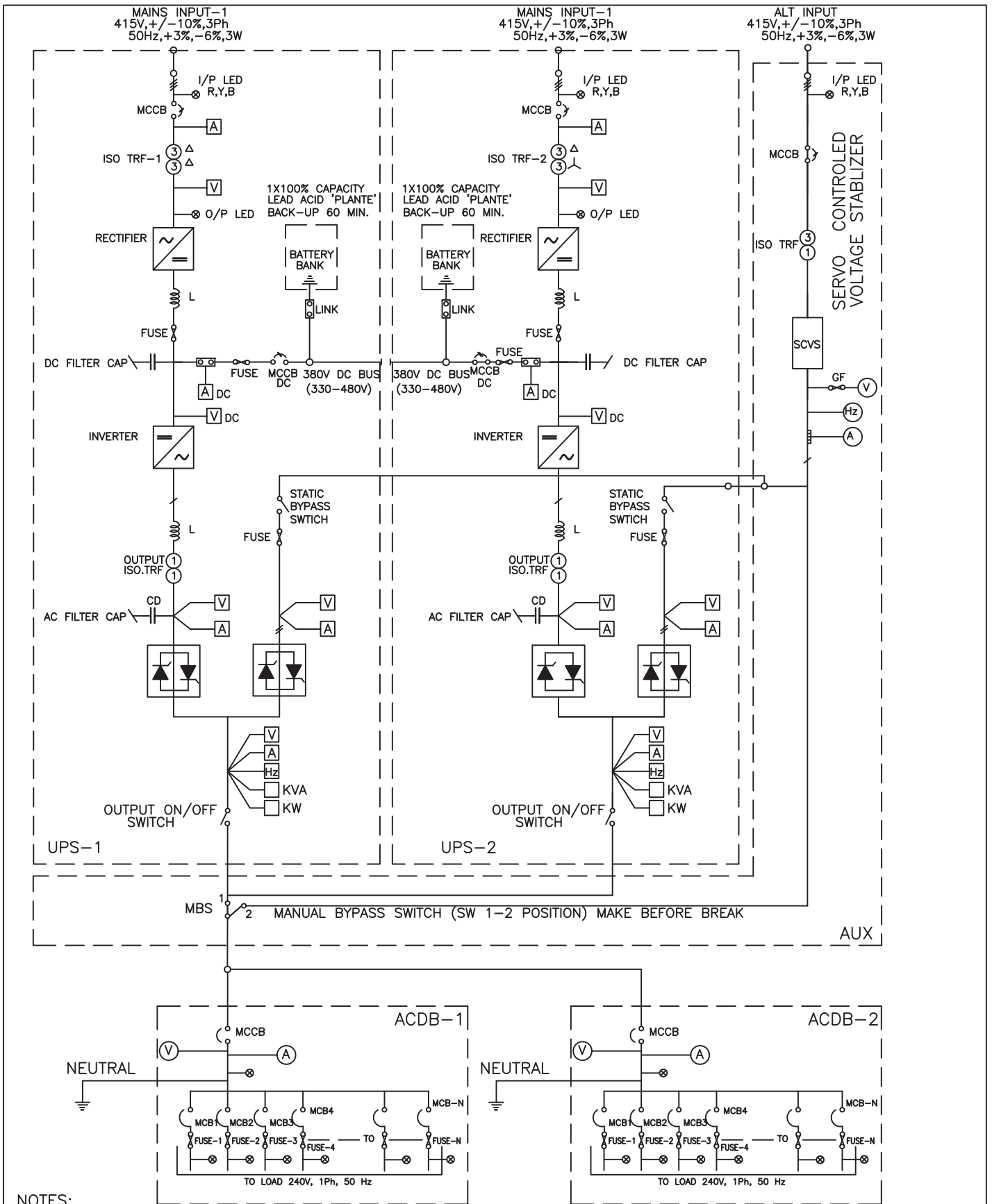

NOTES:

1. ACDB-1&2 NEUTRAL TO BE GROUNDED TO A DEDICATED GROUND.
2. ALL OUTPUT FEEDERS OF ACDB SHALL BE PROVIDED WITH AN LED AFTER THE FUSE FOR FEEDER ON INDICATION WITH FEEDER DESCRIPTION.
3. REDUNDANT FEEDERS SHALL BE LOCATED IN DIFFERENT ACDBs.



1 X 800 MW KOTHAGUDEM TPS

TITLE:--

UPS SINGLE LINE DIAGRAM

DRG. No.

PE-DG-410-145-1004

REV. No.

00

DATE

04.02.2015

SHEET

2

OF

2

	TITLE: TECHNICAL SPECIFICATION FOR CHLORINATION PLANT 1X800 MW TSGENCO KOTHAGUDEM TPS STAGE -VII, PALONCHA	SPEC NO: PE-TS-410-174-A001	
		VOLUME: II-B	
		SECTION: D	
		REV NO: 00	DATE:

LOCAL CONTROL PANEL AND JB DETAILS

- 1.00.00 **GENERAL REQUIREMENT**
- 1.01.00 ENCLOSURES FOR INSTRUMENTS AND OTHER EQUIPMENT
- 1.01.01 All panels, cabinets, distribution boxes, junction boxes, terminal boxes and all other field mounted equipment / enclosures shall have suitable environmental protection as detailed in Section-I of this volume of the specification.
- 1.02.00 SURFACE PREPARATION & PAINTING
- 1.02.01 All sheet metal panel/ desk exterior steel surfaces shall be sand blasted, ground smooth and painted as specified below.
- 1.02.02 Suitable filler shall be applied to all pits, blemishes and voids in the surface. The filler shall be sanded so that surfaces are level and flat; corners are smooth and even. Exposed raw metal edges shall be ground burr-free. The entire surface shall be blast clean to remove rust and scale and all other residue due to the fabrication operation. Oil, grease and salts etc. shall be removed from the panels by one or more solvent cleaning methods prior to blasting.
- 1.02.03 Two spray coats of inhibitive epoxy primer surfacer shall be applied to all exterior and interior surfaces, each coat of primer surfacer shall be of dry film thickness of 1.5 mil. A minimum of two spray coats of final finish color (Catalyzed epoxy or polyurethane) shall be applied to all surface of dry film thickness 2.0 Mil. The finish colors for exterior and interior surfaces shall conform to the following shades:
- Exterior – Opaline green shade 275 of IS: 5 or equivalent international code..
 - Interior - Brilliant White.
- 1.02.04 Paint films, which show sags, cheeks, blisters, teardrops, fat edges or other painting imperfections, shall not be acceptable.
- 1.03.00 WIRING
- 1.03.01 All spare contacts of relays, switches and push buttons shall be wired up to the terminal blocks. All intercommunications between sections of panels/desks shall be furnished.
- 1.03.02 Each wire shall be identified at both ends with wire designation as per approved wiring diagram. Heat shrinkable type ferrules with indelible computerized ink print shall be used with cross- identification.
- 1.03.03 All wire termination shall be made with insulated sleeve and crimping type lugs. Wire shall not be spliced or tapped between terminals. Open-ended terminal lugs will not be accepted. Wires shall not be looped around the terminal screws or studs.

- 1.03.04 Internal wiring should be terminated uniformly on one side of the terminal block leaving the other side available for termination of outgoing cables. Internal wiring shall be grouped so that all outgoing wiring to each particular remote location is terminated on adjacent terminal blocks. Interior wiring and jumperings shall be arranged so that external connections can be made from internal side of terminal blocks. Common connections shall be limited to two (2) wires per terminal.
- 1.03.05 Wiring shall be arranged to ensure free access to all instrument or devices for maintenance. No wire shall be routed across the face or rear of any device in a manner, which will impede the opening of covers or obstruct access to leads, terminals or devices
- 1.03.06 Wires shall be dressed and run in trays or troughs with clamp-on type covers. Wirings may be neatly bunched in groups by non-metallic cleats or bands. Each group shall be adequately supported along its run to prevent sagging or strain on termination.
- 1.03.07 Shield wires shall be terminated on separate terminal blocks. Common connections shall be limited to two wires per terminal. Signal circuit shields shall be grounded at the power supply end only or as recommended by manufacturer.
- 1.03.08 All low level signal cables shall be separately bundled to from control cable and maintained at 300 mm minimum spacing from control bundles.
- 1.03.09 Panel internal wiring shall follow distinct color-coding to segregate different voltage levels viz. 24V DC, 48V, 110V AC, 240V AC, 220V DC etc.
- 1.03.10 Thermocouple lead wires, analyzer measuring lead wires, or any other lead wires carrying measuring signal of the order of low milli volt or micro volt shall be electrically and physically isolated from other AC and DC wiring. Shielded wires used in such cases for panel internal wiring shall be continuous and ungrounded with the shield terminated individually and separately in panel terminal block.
- 1.03.11 Wiring to door mounted devices shall be provided with multi-strand wires of (49 strands minimum) adequate loop lengths of hinge-wire so that multiple door openings will not cause fatigue failure of the conductor.
- 1.03.12 Internal wiring in factory pre-wired electronic systems cabinets may be installed according to the Contractor's standard wire size, insulation, and method of termination on internal equipment. Insulation for all wiring, including circuit board wiring, back panel wiring, power supply wiring and interconnecting cables between devices shall pass the vertical flame test per IPCEAS-1981. Identification of conductors may be done by insulation color-coding identified on drawings or by printed wiring lists.

- 1.04.00 TERMINAL BLOCKS
- 1.04.01 All terminal blocks shall be rail mounted/ post mounted type, cage clamp type with high quality non-flammable insulating material of melamine suitable for working temperature of 105 Deg C. The terminal blocks in field mounted junction boxes, instrument enclosures racks etc. shall be suitable for cage clamp connections. The terminal blocks in Control Equipment Room termination/ marshalling cubicles shall be suitable for post mounted cage clamp connection at the field input end. The exact type of terminal blocks to be provided by Bidder shall be subject to Owner.
- 1.04.02 All terminal blocks shall be provided complete with all required accessories including assembly rail, locking pin and section, end brackets, small partitions, transparent covers, support brackets, distance sleeves, warning level, marking etc. For RTDs ring - tong type lugs shall be used at Junction Boxes.
- 1.04.03 The characteristics of the terminal blocks shall be as follows.
- i) High contact force, independent of conductor cross-section and large contact surface area.
 - ii) Integrated self-loosening protection to avoid shifting of contact surface that may allow contamination of connection point.
 - iii) Inspection and maintenance free (resistant to thermal aging and vibration)
 - iv) Low and constant voltage drop
- 1.04.04 The insulation of the terminal blocks shall be of suitable thermoplastic material.
- 1.04.05 The spacing between Terminal blocks channels in panels and cubicles shall be adequate for routing the cable troughs and to allow adequate free workspace for termination and removal of wires. The terminal blocks shall be arranged with atleast 100 mm clearance between two sets of terminal blocks and junction box walls.
- 1.04.06 Signals of different voltage levels shall be clearly segregated by providing separate rows to each type of signal and by using terminal blocks of different color for each type of signal and by providing barrier strips between them.
- 1.04.07 Terminal blocks shall be provided with white marking strips / self-adhesive marker cards and where permitted by the safety codes and standards, shall be without covers. Power terminals and high voltage (above 48 volts) terminals shall have protection covers. All terminals shall be provided with permanent terminal identification numbers on both sides.
- 1.04.08 At least 20% spare unused terminals shall be provided on each terminal block for circuit modifications and for termination of all conductors in a multi-conductor control cable.

- 1.04.09 The bottom of the terminal block shall be at least 200 mm above the cable gland for bottom entry type panels.
- 1.04.10 For extending 24 V DC supply to panels, the size of the terminals shall be decided based on voltage drop and not based on current.
- 1.04.11 Other requirements of the terminal blocks are as follows:
- i) The last terminal in a rail-mounted assembly shall be closed with an end plate and end bracket.
 - ii) For visual and electrical separation of terminal groups, partition plates shall be provided, which can be push fitted after forming an assembly.
 - iii) Design shall permit testing of incoming and outgoing signals by using suitable test plug and socket without disconnecting the cable connections.
 - iv) It shall be possible to use jumper plugs through the above test plug socket to connect adjacent terminals. Adequate number of short circuit jumper plugs shall be provided for the purpose.
 - v) Where more than one connection to a terminal block is required, two tier terminals shall be used.
- 1.05.00 **GROUNDING**
- 1.05.01 Separate Protective and Electronic system ground as required shall be provided.
- 1.05.02 All panels, desks, cabinets shall be provided with a continuous bare copper ground bus (Frame ground), bolted to the panel structure at bottom on both sides and effectively ground the entire structure. The bolts shall face inside of panels.
- 1.05.03 For electronic system cabinets the electronic system ground bus (Electronic ground) shall be similar but insulated from the cabinet and shall be separately connected to the system ground .The same ground may be used to earth the shield of shielded signal cables, otherwise a separate ground bus shall be provided for connecting the signal cable shields. Cable shields shall be grounded at the panel end only and shall never be left open .The electronic ground between panels of a shipping section shall be firmly looped.
- 2.00.00 **CONTROL DESKS & PANELS**
- 2.01.00 **GENERAL**
- 2.01.01 All control desk, panels etc. shall be furnished fully wired with necessary provision for convenience outlets, internal lighting, utility receptacles, grounding, ventilation, space heating, anti-vibration pads, internal piping &

- accessories as required for completeness of the system.
- 2.01.02 The design shall conform to the EN ISO 11064 (Ergonomical design of Control Room), Part 1, 2 and 3.
- 2.01.03 The exact dimensions, material, construction details, grounding, general arrangement etc. shall be as per actual requirement and shall be finalized during detail engineering and subjected to Owner's approval.
- 2.01.04 Incoming power supply feeders shall be duplicated. Alarm shall be provided for failure of a power supply feed.
- 2.01.05 For Control desk/ panel mounted instruments/ devices etc. which are to be powered from UPS, all required conversion of interface equipments/ accessories to make such devices compatible with UPS supply shall be provided. All necessary hardware like input switches/ fuse unit for each feeder as well as switch fuse unit for each instrument/ device on the power supply line shall be provided. From UPS redundant feeders shall be provided with suitably rated MCB and provision of fast auto changeover of UPS feeders.
- 2.01.06 Crating of the panels and desks shall be suitable for protection against shock, vibration, inappropriate handling and inclement weather conditions during transportation and warehousing. Mounted equipment shall have adequate protection against damage during handling, transit and storage. Suitable desiccant shall be used inside the packing case.
- 2.01.07 Nameplate
- a) Nameplate shall be provided for instrument or device mounted on the panel.
 - b) Nameplates for panels shall be provided both in front and rear.
- 2.02.00 CONTROL DESK
- 2.02.01 Control desk shall be free standing, floor mounting, table top type with doors at back and shall be constructed of 3 mm thick (minimum) CRCA steel or Aluminium extrusion. Aluminium structure shall be anodized or powder coated paint finish. The top surface of control desk shall be 30 mm (minimum) thick with the top 12 mm (minimum) of acrylic solid surface and the remaining 18 mm of laminated medium density fibre (MDF) board.
- 2.02.02 Monitors with retractable keyboard shall be provided on the desk. Desk shall be arranged in arc-like shape without any sharp edges. Edges shall be extruded PVC or rounded post-formed laminate.
- 2.02.03 Desks shall be of modular, scalable and industrially ruggedized design and shall have connections for PA system handsets & telephone sets.
- 2.02.04 Desks shall have concealed cable trays for wire dressing. Both Horizontal & Side Managers (2 separate horizontal cable routing wire baskets for power & data cables) shall be provided.

Each User station will be provided with 2 separate power distribution units (1 for Main line & 1 for UPS line). Each power distribution unit will have 6 points of 5/13 Amp sockets, Mains MCB On/Off Switch & Indicator.

Adequate heat management provision for Exhaust of heat from within the Console Desk Assembly shall be provided. There will be multiple fans provided in the Main Control Desk. Each Fan will be of 230 VAC 250 CFM Ball Bearing based. Ventilation louvers will be provided on both Front & Rear Modesty with special Air Filters. Adequate space for CPU & Other equipments placed with in the desk.

2.02.05 Design shall include Earthing bolts.

2.02.06 Back installed items shall be suitably concealed from front view.

2.02.07 All operator workstations for SG, TG, Auxiliaries & Off-site Plants shall be mounted on this Control Desk. The cabling / wiring between OWS & CPUs, power supply cables etc. shall be aesthetically routed and concealed from view.

2.02.08 HARDWIRED DEVICES ON CONTROL DESK (DRAW OUT SECTION)

Release and Lamp Test push buttons shall be provided for a set of push buttons (decided during detail engineering stage). Depending on the type of control/ function, required number of push buttons/ indicating LEDs & their color, push button stations shall be selected. The size of push button stations shall be 24 x 48 mm or 25 x 50 mm and shall have service inscription details at the front. Emergency push buttons (with cover) shall be mounted on top of Control Desk.

2.03.00 BACK UP PANEL

2.03.01 Construction shall be from CRCA steel of thickness not less than 3mm.

2.03.02 Upright back-up panel shall be provided where hardwired devices shall be mounted on a mosaic grid type console. The mosaic grid tiles shall be of 24 mm x 48 mm (or 25 mm x 50 mm) size, made of heat & flame retardant, self extinguishing and non-hygroscopic material with flat matt finish without glare and non reflecting type.

2.03.03 DDCMIS Back-up Panel (referred as Unit Control Panel-UCP) shall also mount annunciation fascia (minimum 500 nos.) and the flame monitoring cameras along with other hardwired devices as decided during detail engineering stage by Owner. Color coding shall also subject to Owner's approval.

2.03.04 Colored Mimic for different Off-site plant control systems (as enumerated elsewhere in this specification) and hardwired annunciation system shall also

be mounted on the back up panels.

2.04.00 PANELS/CABINETS

2.04.01 All DDCMIS system modules, power supply components and other Local Control panels (PLC/Relay based) shall be housed in cabinets as specified below.

2.04.02 The cabinet mounted equipments shall be fully assembled, installed in mounting racks, wired and fully tested as per specification requirements and Owner approved drawings prior to shipment to the project site.

2.04.03 The Bidder shall ensure that the cabinets are complete & ready for installation before dispatch from manufacturing works. The installation work at project site for these cabinets shall only involve connections through multi-pair cables from marshalling cabinets (wherever provided) to system cabinets and inter-cabinet/cabinet to Control Desk/ Back up Panel.

2.04.04 All electronic cards, network components, power supply modules etc. located shall be suitably housed in cabinets and shall be neatly arranged in sub-racks. Network components shall be visible in door closed condition (e.g. Glass doors etc.) as approved by Owner.

2.04.05 Bidder shall design the cabinet internal arrangement, floor cutout and cable gland plate such that all the cables entering or leaving the cabinet can be properly glanded in the gland plate.

2.04.06 The packaging density of panels shall be such that the temperature rise within the panels shall never exceed 10°C above ambient even under worst operating conditions. Cooling Fans shall be provided wherever required and this shall be of industrial grade.

2.04.07 TECHNICAL PARTICULARS

1. Material of Construction : Cold Rolled Coal Annealed (CRCA) steel sheet
2. Thickness of Sheet : a) 2.0 mm for faces supporting instruments / terminals
: b) 1.6 mm for other sides and top
3. Construction : Welded throughout as per approved National Standards
4. Post welding operation : a) Grounding of all welds to smoothness
: b) Rounding of corners

- : c) Cleaning of weld spatters
- 5. Panel height : 2300 mm (approx)
- 6. Corners : 7 mm inner radius
- 7. Dimensional Tolerances :
 - a) In height & length - 3 mm
 - b) In height between adjacent sections - 2 mm
 - c) Total for a group - 6 mm
- 8. Doors : Double, recessed, turned back edges, full height front & rear
 - i) Thickness of Sheet : 2 mm
 - ii) Hinges : Stainless steel
 - iii) Door latches : Three point type
 - iv) Door gaskets : Neoprene rubber on fixed frame to result dust proof/weatherproof enclosure
 - v) Opening of the doors : Outward
 - vi) Louvers : With removable wire mesh to ensure dust and vermin proof
- 9. Gland plates : Removable in sections
4 mm thick (bottom)
- 10. Cable entry : Bottom
- 11. Hardware :
 - a) Anti vibration pad- 15 mm
 - b) Predrilled base channel ISMC – 100 or equivalent for all sides
 - c) Stainless steel buff- finished 2 mm thick kick plate for all sides
 - d) Stainless steel scratch strips along desk edges fixed with pan-head recessed screws
 - e) Rubber strips to ensure air

- tightness between kick plate and finished floor
- f) Lifting hook / Eye bolt
- g) Drawing pocket
- Door switch, lamps, thermostat,
- h) heaters and industrial grade cooling fans,, illumination fixtures
12. Name Plate : Both at front and back surface of the panel
13. Fixing of name plate : Stainless steel pan head screws
14. Name plate material : Laminated phenolic (3 layers)
15. Lettering : Black with white engraved
16. Mounting of terminal blocks : Vertical angle support bracket tack welded on sheet steel plate, screwed on internal wall of enclosure

2.05.00 FURNITURE

All the furnitures in the Central / Local control Room (s), Engineers' rooms, Instrument laboratory , SWAS Room & any other rooms with C&I equipments located in different plant buildings under Bidder's scope shall be included in Bidder's scope of supply. Bidder shall provide following industrial grade furniture items as a minimum from reputed manufacturers/suppliers meeting International Standards. The furniture shall be modular and latest with ease of operational features. The furniture shall be modern, aesthetically designed, modular, flexible, space saving and future safe.

2.05.01 WORK STATION FURNITURE

Modular work station furniture, suitable for mounting servers & historians, programmer stations, PC based systems, printers (A4/A3 color laserjet) etc. shall be provided.

2.05.02 PC RACK

PC Racks shall be provided to mount CPUs of workstations/PCs of OWS/LVS etc. in control room. For each PC / workstation / monitor at least one chair shall be included.

2.05.03 CHAIRS

Industry standard revolving chairs with wheels and with provision for adjustment of height (hydraulically/gas lift) shall be provided for the operators, unit-in-charge & other personnel in control room area. These shall be designed for sitting for long duration such that these are comfortable for the back.

2.05.04 TABLES

Industry standard computer tables shall be provided & shall be as approved by Owner during detailed Engineering. Glass top teak wood horse shoe shaped table with vertical file mounting arrangement (two layers to house approx. 40 Nos of files and lockable drawers at both ends) for Engineering Room shall be provided.

2.05.05 ALMIRAHS

Steel Almirahs shall be provided for keeping documents in the documentation room. Glass doors for each rack shall be provided such that the documents are visible from outside. Size of the rack shall be sufficient to easily fit technical manuals. The exact details shall be approved by Owner during detailed Engineering.

2.05.06 KEYPAD

One keypad per unit shall be provided for the storing of keys of relevant areas of the unit in the control room.

2.05.07 LOCKERS

Suitable lockers shall be provided in the room adjacent to the control room for storing of personal articles of control room personnel. Also, lockers of bigger size shall be provided in documentation Room for storing of personal documents. Details shall be finalized and approved by Employer during detailed engineering.

3.00.00 **LVS PANEL**

3.01.00 An arc shaped Large Video Screen (LVS) panel shall be supplied for mounting large video screens in number of tiers in various Control rooms as specified elsewhere in this specification.

Bidder shall provide and fix ACP cladding around the LVS screen including covering the LVS back side and LVS stand. The cladding will be from floor finish to 600 mm above LVS screen like a self-standing partition with necessary openings for system requirement. ACP paneling shall be with 304 grade & approx. 0.5 mm mirror finish SS strip.

3.02.00 The profile, dimensions and the general arrangement shall be finalized & approved by Owner during detailed engineering. Recommendations, if any, for the control room lighting in order to ensure continuous proper viewing of the LVS screen by the operator & shift incharge (without any fatigue) shall be

- clearly brought out by the Contractor in his offer, alongwith all relevant details/basis.
- 3.03.00 Any other requirement for proper LVS mounting & functioning & viewing shall also be specifically brought out by the Contractor in his offer, along with all relevant details.
- 4.00.00 **LOCAL INSTRUMENT RACK (LIR) & LOCAL INSTRUMENT ENCLOSURE (LIE)**
- 4.01.00 GENERAL
- 4.01.01 Devices (Transmitters/ Switches) located in the field shall be suitably grouped together to the extent possible and installed in the LIE (Closed Rack) and LIR (Open Rack) in Boiler/TG Building and Off-site plant areas.
- 4.01.02 Racks and enclosure shall be factory prefabricated & painted and shall complete with internal piping, tubing, manifold, isolation valves, blowdown valves, integral junction box, illumination etc.
- 4.01.03 No more than six instruments shall be grouped in a single rack / enclosure.
- 4.01.04 Racks shall be installed above the tapping points for air, flue gas and coal air mixture application whereas for applications such as for water and steam, racks to be installed below the source point.
- 4.01.05 Attention shall be paid in the layout to avoid air traps in liquid piping and water accumulation in air /gas piping.
- 4.01.06 Racks used for furnace, flue gas and air application shall be provided with intermittent & continuous air purging
- 4.01.07 Welding of impulse lines shall comply with the provisions of the latest applicable ANSI Code for Pressure Piping.
- 4.01.08 Earth stud shall be furnished at rack for safety grounding.
- 4.02.00 LOCAL INSTRUMENT ENCLOSURE (LIE)
- 4.02.01 Enclosure shall be free standing type. Racks shall be adequately reinforced to ensure true surfaces and to provide support. Major load - bearing posts shall be suitably supported by gusset plates or moment members.
- 4.02.02 Enclosure outer shall be constructed from at least 3 mm thick steel plate and epoxy painted to shade gray. Base frame shall be made of ISMC 100 and black colour finish.
- 4.02.03 2" NB galvanized pipes shall be laid horizontally and supported at two end channels to mount transmitters at accessible height. Center posts or any

- member, which would reduce access, shall be avoided.
- 4.02.04 Double leaf interlocking front opening doors with three point locking shall be provided and shall be arranged for maximum possible access to the interior. Key shall be of identical for all enclosures.
- 4.02.05 Doors shall have concealed quick removal type pinned stainless steel hinges and locking handles. Gaskets shall be used between all mating sections to achieve dust and weather proof enclosure rated for IP-65 including the internal junction box. All enclosures shall have access doors on front side.
- 4.02.06 Removable type bulkhead plates of thickness not less than 6 mm shall be mounted at the racks with suitable high temperature gasket. Impulse lines within the enclosures shall be properly clamped.
- 4.02.07 All internal wirings between the instruments and junction box shall run through flexible conduits. No exposed wirings within transmitter racks both open and closed type, is admissible.
- 4.02.08 Racks shall have a common blowdown drain header, which will connect individual instrument blowdown line after suitable pressure breaking through regulating globe type blowdown valves. Covered funnels shall be used for saturated liquid and steam service, whereas, open funnels may be used for cold liquid services. Header (2" NB ASTM A 106, Sch-80 Gr. C) shall be suitably sloped and shall have one end flanged and extending beyond the rack for connection to plant drain header..
- 4.02.09 Each rack shall be provided with one receptacle, light fixtures with wire guard and one lighting switch each at instrument & Junction box compartments with wire guard. Lighting switches may be door actuated & mounted inside the panel. Outlet box, switch box and device covers shall be of galvanized stamped steel. Light switches and receptacles shall be installed inside the enclosure on the wall near the latch side of the enclosure door. Light fixtures shall be installed on the ceilings of the enclosures.
- 4.02.10 Power supplies for miscellaneous devices shall be provided with MCB located within the enclosures. MCB shall be mounted in fuse blocks. Nameplates shall be furnished above the MCB blocks, identifying the devices being served.
- 4.02.11 Vibration dampeners shall be installed for supporting each enclosure. The loading at each corner of the enclosure shall be determined by actual test weighting when construction is complete to determine the correct length of each dampener for proper loading of the dampener in accordance with manufacturer's recommendations
- 4.03.00 LOCAL INSTRUMENT RACK (LIR)
- 4.03.01 Rack shall be free standing type constructed from 6 mm thick steel channel frame provided with a canopy to protect the instrument from dripping water or

falling objects and shall be epoxy painted. Canopy shall be of CRCA steel sheet of at least 3 mm thickness.

4.03.02 Rack Major load-bearing posts shall be suitably supported by gusset plates or moment members. Suitable fenders grill shall be welded to the end-posts of the rack to outline a boundary beyond which no mounted equipment shall project to protect instrument from accidental contact during personnel movement. Center posts or any member, which would reduce access, shall be avoided.

4.03.03 2" NB galvanized pipes laid horizontally and supported at two end channels shall be employed at working accessible height for mounting of instruments.

4.03.04 All internal wirings between the instruments and junction box shall run through flexible conduits. No exposed wirings are admissible.

4.03.05 Racks shall have a common blowdown drain header, which will connect individual instrument blowdown line after suitable pressure breaking through regulating globe type blowdown valves. Covered funnels shall be used for saturated liquid and steam service, whereas, open funnels may be used for cold liquid services. Header (2" NB ASTM A 106, Sch-80 Gr. C) shall be suitably sloped and shall have one end flanged and extending beyond the rack for connection to plant drain header..

Each rack shall be provided with one receptacle, one light fixture with wire guard and one lighting switch. Outlet box, switch box and device covers shall be galvanized stamped steel. Light fixtures shall be installed on the canopy of the rack

4.03.06 Power supplies for miscellaneous devices shall be provided with MCB located within the enclosures. MCB shall be mounted in fuse blocks. Nameplates shall be furnished above the MCB blocks, identifying the devices being served.

4.04.00 JUNCTION BOX

1. Type of Enclosure : Dust tight & weatherproof conforming to IP 65
2. Material : 3 mm sheet steel / fiberglass reinforced polyester(UV stabilized)
3. Type of Cover : Solid unhinged with retention chain / Screwed at all four corners
4. Paint :
 - i) Exterior : Opaline green shade 275 of IS: 5
 - ii) Interior - Brilliant Glossy White.

- Surface / Two (2) inch Pipe stanchion
5. Mounting : (At a dry compartment at one side of the enclosure / rack with front opening type door)
6. Cable Entry : 3 mm (min) Bottom / side Gland plate
7. Gasket : Neoprene
8. Grounding : Brass earth lug with green screw head
External-2 nos , Internal-1no. (M6)
9. Number of Drain Holes : Two at bottom capped
10. Identification : Label for JB and Tags for cable
11. Accessories : Rail mounted cage clamp type screwless terminals (suitable for conductor size up to 2.5sq.mm of suitable voltage grade) with markers and 20% spare terminals
- b) Cable gland (Brass) & raceways
 - c) Ferrules & lugs (Brass)
 - d) Aluminum back panel
 - e) Canopy at top
 - f) Mounting brackets
 - g) bolts and nuts made of brass etc.



DATA SHEET FOR LOCAL PANELS

SPECIFICATION NO.: PE-SS-999-145-054A

VOLUME

SECTION

REV. NO. 02

DATE: 16.09.2013

SHEET 1 OF 3

TAG No. Qty.....

Data Sheet No.: PES-145A-DS1-0

Data Sheet A & B

DATA SHEET-A FOR LOCAL PANEL
(TO BE FILLED BY PURCHASER)

DATA SHEET-B
(TO BE FILLED-UP BY
BIDDER)

GENERAL	MANUFACTURER	
	CONSTRUCTION	<input checked="" type="checkbox"/> FOLDED <input type="checkbox"/> WELDED
	ENCLOSURE SHEET THICKNESS (As per Section 8.13, Volume V of contract specification)	FRONT <input type="checkbox"/> 2.0 mm
		OTHER <input type="checkbox"/> 2.0 mm
		DOOR <input type="checkbox"/> 1.6 mm
		HEIGHT <input type="checkbox"/> 2365 mm for stand alone panels. <input type="checkbox"/> Other
		OTHER <input type="checkbox"/> Load bearing sheet front shall have 3mm thickness
TECHNICAL	INPUT POWER SUPPLY * (As per Electrical specification) (ANY OTHER POWER REQUIREMENT TO BE DERIVED FROM THIS SUPPLY ONLY)	<input type="checkbox"/> 240V 50 Hz AC <input type="checkbox"/> 220V DC <input checked="" type="checkbox"/> 415V 3 PHASE 3W <input type="checkbox"/> 400V 3 PHASE 4W
	NO. OF FEEDERS (As per Electrical specification)	<input type="checkbox"/> ONE <input type="checkbox"/> TWO
	STARTER WITH MCC	<input type="checkbox"/> REQUIRED <input checked="" type="checkbox"/> NOT REQUIRED
	IPR POSITION	<input checked="" type="checkbox"/> MCC <input type="checkbox"/> RELAY PANEL
	CONTACT RATING OF RELAY	<input checked="" type="checkbox"/> 5 Amp, 230 V AC <input checked="" type="checkbox"/> 0.25 Amp, 220V DC
	CONTROL SUPPLY	<input type="checkbox"/> 110V AC <input type="checkbox"/> 220V AC <input type="checkbox"/> 220V DC <input type="checkbox"/> Other. (As per requirement)
	ALARM ANNUNCIATOR WINDOW (EXCLUDING SPARES)	_____ NOS. (AS REQUIRED)
	TEMP SCANNER (IF REQUIRED -NO. OF CHANNELS TO BE SPECIFIED UNDER SEC-C)	<input type="checkbox"/> REQUIRED <input checked="" type="checkbox"/> NOT REQUIRED
	PAINT TYPE (As per Annex-1, Section 7.6, Volume IV of contract specification)	<input type="checkbox"/> EPOXY ENAMEL <input type="checkbox"/> EPOXY POWDER COATED
	MIMIC (TYPE OF MIMIC- MATERIAL, THICKNESS TO BE SPECIFIED DURING DETAILED ENGG.)	<input checked="" type="checkbox"/> REQUIRED <input type="checkbox"/> NOT REQUIRED
	PANEL COLOUR (EXTERNAL) (As per Annex-1, Section 7.6, Volume IV of contract specification)	<input type="checkbox"/> LIGHT GREY <input type="checkbox"/> OPALINE GREEN
	FINISH (EXTERNAL) (As per Annex-1, Section 7.6, Volume IV of contract specification)	<input type="checkbox"/> MATT <input type="checkbox"/> GLOSSY <input type="checkbox"/> SEMI GLOSSY
	PANEL COLOUR (INTERNAL) (As per Annex-1, Section 7.6, Volume IV of contract specification)	<input type="checkbox"/> WHITE <input type="checkbox"/> CREAM <input type="checkbox"/> OFF WHITE
	FINISH (INTERNAL) (As per Annex-1, Section 7.6, Volume IV of contract specification)	<input type="checkbox"/> MATT <input type="checkbox"/> GLOSSY <input type="checkbox"/> SEMI GLOSSY
	CLASS OF PROTECTION	<input checked="" type="checkbox"/> IP-55 (FOR INDOOR SERVICE) <input checked="" type="checkbox"/> IP-67 (FOR OUTDOOR SERVICE) <input type="checkbox"/> ANY OTHER
	CONTROL HARDWARE	<input checked="" type="checkbox"/> RELAY BASED
	FOUNDATION ARRANGEMENT	<input type="checkbox"/> FOUNDATION BOLTS <input type="checkbox"/> ANCHOR FASTENERS
	WEIGHT OF PANEL (Kg.)(Vendor to specify)

	DATA SHEET FOR LOCAL PANELS			SPECIFICATION NO.: PE-SS-999-145-054A		
				VOLUME		
				SECTION		
				REV. NO. 02	DATE: 16.09.2013	
TAG No. Qty.....			Data Sheet No.: PES-145A-DS1-0			
Data Sheet A & B						
DATA SHEET-A FOR LOCAL PANEL (TO BE FILLED BY PURCHASER)				DATA SHEET-B (TO BE FILLED-UP BY BIDDER)		
	PANEL TYPE		<input type="checkbox"/> PRESSURISED <input type="checkbox"/> UNPRESSURISED As per Requirement			
	CABLE GLAND		<input checked="" type="checkbox"/> DOUBLE COMPRESSION			
	AMMETER (TYPE OF INPUT) *		<input type="checkbox"/> 1 Amp CT <input type="checkbox"/> 4-20 mA			
	SCOPE OF SUPERVISION FOR ERECTION & COMMISSIONING		<input type="checkbox"/> APPLICABLE <input checked="" type="checkbox"/> NA			
	* TO BE CO-ORDINATED WITH PEM ELECTRICAL					
NAME DESIGNATION SIGNATURE DATE	PREPARED BY		CHECKED BY		APPROVED BY	
	AANCHAL CHOUDHARY		SACHIN SRIVASTAVA		MA MANSOORI	
	SR.ENGR		DY.MNGR		D. GM	
					COMPANY SEAL	
					NAME:	
					SIGNATURE:	
					DATE:	
16.09.2013		16.09.2013		16.09.2013		



DATA SHEET FOR LOCAL PANELS

SPECIFICATION NO.: PE-SS-999-145-054A

VOLUME

SECTION

REV. NO. 02

DATE: 16.09.2013

SHEET 3 OF 3

TAG No. Qty.....

Data Sheet No.: PES-145A-DS1-0

Data Sheet C

DATA SHEET-C FOR LOCAL PANEL
(TO BE FILLED BY CONTRACTOR AFTER AWARD OF CONTRACT)

GENERAL	MANUFACTURER		
	CONSTRUCTION	<input type="checkbox"/> FOLDED <input type="checkbox"/> WELDED (As per requirement EDN)	
	ENCLOSURE SHEET THICKNESS	FRONT	
		OTHER	
		DOOR	
		HEIGHT	
		OTHER	
TECHNICAL	INPUT POWER SUPPLY		
	NO. OF FEEDERS		
	CONTACT RATING OF RELAY		
	TEMP SCANNER		
	CONTROL SUPPLY		
	ALARM ANNUNCIATOR WINDOW (EXCLUDING SPARES)		
	PAINT TYPE		
	PANEL COLOUR (EXTERNAL)		
	FINISH (EXTERNAL)		
	TYPE OF MIMIC MATERIAL OF MIMC THICKNESS OF MIMIC		
	PANEL COLOUR (INTERNAL)		
	FINISH (INTERNAL)		
	CLASS OF PROTECTION		
	CONTROL HARDWARE		
	FOUNDATION ARRANGEMENT		
	WEIGHT OF PANEL (Kg.)		

	DATA SHEET FOR LOCAL PANELS			SPECIFICATION NO.: PE-SS-999-145-054A	
				VOLUME	
				SECTION	
				REV. NO. 02	DATE: 16.09.2013
TAG No. Qty.....		Data Sheet No.: PES-145A-DS1-0			
Data Sheet C					
DATA SHEET-C FOR LOCAL PANEL (TO BE FILLED BY CONTRACTOR AFTER AWARD OF CONTRACT)					
	PANEL TYPE				
	CABLE GLAND				
	AMMETER (TYPE OF INPUT)				
	SCOPE OF SUPERVISION				
NAME SIGNATURE DATE	PREPARED BY	CHECKED BY	APPROVED BY		COMPANY SEAL NAME: SIGNATURE: DATE:
	AANCHAL CHOUDHARY	SACHIN SRIVASTYAVA	MA MANSOORI		
	16.09.2013	16.09.2013	16.09.2013		



Technical specification for
CONTROL & INSTRUMENTATION

1X800 MW KOTHAGUDEM

SPEC NO.: **PE-TS-410-145-I**

VOLUME

SECTION

REV. NO. 00

DATE : 10.03.2015

SHEET OF

LCP Quality Plan



PEM :: C&I

STANDARD QUALITY PLAN FOR LOCAL CONTROL PANEL

STD QUALITY PLAN NO.: PE-QP-999-145-1056

VOLUME IIB

SECTION D

REV. NO. 01 DATE: 22-02-2008

SHEET 1 OF 7

Sl. No.	Component / operation	Characteristics Checked	* Category	Type/Method of Check	Extent of Check	Reference documents	Acceptance Norms	Format of Records	Agency \$			Remarks	
									P	W	V		
INCOMING													
1.0	Sheet Steel (CRCA & HR)	1. Chemical Composition 2. Bend Test 3. Surface finish 4. Waviness 5. Thickness 6. Mill marking	MA CR MA MA MA MA	Chemical analysis Mech. test Visual Visual Measurement Visual	Sample Sample 100% 100% 100% 100%	Relevant standard Relevant standard Factory Standard / Sample Factory Standard BHEL Spec. Factory Standard	Relevant standard Relevant standard Factory Standard / Sample No Waviness BHEL Spec. Factory Standard	Test Certificate Log Book Log Book Log Book Log Book Log Book	3 2 2 2 2 2	---	---	2 --- --- --- --- 1	
2.0	Flats / Angles / Channels	1. Dimensions 2. Surface Defects 3. Straightness 4. Mill marking	MA MA MA MA	Measurement Visual Measurement Visual	Sample 100% 100% 100%	Relevant standard Factory Standard / Sample Factory Std. Relevant standard	Relevant standard Factory Standard / Sample Factory Std. Relevant standard	Log Book Log Book Log Book Log Book	2 2 2 2	---	---	--- --- --- 1	
3.0	Cables / Wires	1. Visual / Surface defects 2. IR and HV	MA MA	Visual Electrical	100% 100%	BHEL Spec. and Relevant standard BHEL Spec. and Relevant standard	BHEL Spec. and Relevant standard BHEL Spec. and Relevant standard	Log Book Log Book	2 2	---	---	--- ---	

LEGEND: * CR - Critical characteristics
MA - Major characteristics
MI - Minor characteristics

\$ P - Agency Performing the Test.
W - Agency Witnessing the Test.
V - Agency Verifying the Test.

1 - BHEL
2 - Vendor
3 - Sub-vendor



STANDARD QUALITY PLAN FOR LOCAL CONTROL PANEL

STD QUALITY PLAN NO.: **PE-QP-999-145-1056**
 VOLUME IIB
 SECTION D
 REV. NO. **01** DATE: **22-02-2008**
 SHEET 2 OF 7

Sl. No.	Component / operation	Characteristics Checked	* Category	Type/Method of Check	Extent of Check	Reference documents	Acceptance Norms	Format of Records	Agency \$			Remarks
									P	W	V	
		3. Conductor a) Resistance b) Size c) Sheet colour	MA MA MA	Electrical Measurement Visual	100% 100% 100%	BHEL Spec. and Relevant standard	BHEL Spec. and Relevant standard	Log Book	2	---	---	
		4. Type / Routine Test Certificates	MA	Verification	100%	BHEL Spec. and Relevant standard	BHEL Spec. and Relevant standard	Log Book	3	---	2	
4.0	Electrical Components like Annunciator Transformers Lamps Switches PBs Contactors Relays Timers Space Heaters Thermostat Indicating meters etc.	1. Verification at make and Type	CR	Visual	Sample	BHEL Spec. and BOM	BHEL Spec. and BOM	Log Book	2	---	---	
		2. Verification of Test Certificates	CR	Scrutiny of Type / Routine T.Cs.	100%	Relevant standard	Relevant standard	Log Book	2	---	---	
		3. Operation / Functional check	CR	Electrical	Sample+ 100%@	Relevant standard & Catalogue	Relevant standard & Catalogue	Log Book	2	---	---	+ for relay & contactors only
		4. I.R.	MA	Electrical	100%	Relevant standard & Catalogue	Relevant standard & Catalogue	Log Book	2	---	---	@ for all components except relays & contactors.
		5. H.V.	MA	Electrical	100%	Relevant standard & Catalogue	Relevant standard & Catalogue	Log Book	2	---	---	
		6. Calibration	MA	Electrical	100%	Relevant standard & Catalogue	Relevant standard & Catalogue	Log Book	2	---	1	
		7. Pick up / Drop off Voltage	MA	Electrical	100%	Relevant standard & Catalogue	Relevant standard & Catalogue	Log Book	2	---	---	

LEGEND: * CR - Critical characteristics
 MA - Major characteristics
 MI - Minor characteristics

\$ P - Agency Performing the Test.
 W - Agency Witnessing the Test.
 V - Agency Verifying the Test.

1 - BHEL
 2 - Vendor
 3 - Sub-vendor



PEM :: C&I

STANDARD QUALITY PLAN FOR LOCAL CONTROL PANEL

STD QUALITY PLAN NO.: PE-QP-999-145-1056

VOLUME IIB

SECTION D

REV. NO. 01 DATE: 22-02-2008

SHEET 3 OF 7

Sl. No.	Component / operation	Characteristics Checked	* Category	Type/Method of Check	Extent of Check	Reference documents	Acceptance Norms	Format of Records	Agency \$			Remarks	
									P	W	V		
5.0	Misc. Components like Gaskets, Terminal Blocks etc.	1. Verification of Type / Make 2. Surface defects 3. IR / HV on Terminal Blocks	MA MA MA	Visual Visual Electrical	Sample Sample Sample	BHEL Spec. & Mfrs. Catalogue BHEL Spec. & Mfrs. Catalogue BHEL Spec. & Mfrs. Catalogue	BHEL Spec. & Mfrs. Catalogue BHEL Spec. & Mfrs. Catalogue BHEL Spec. & Mfrs. Catalogue	Log Book Log Book Log Book	2 2 2	---	---	---	
6.0	IN PROCESS Blanking / Bending / Forming	1. Dimensions 2. Surface defects after bending	MI MA	Measurement Visual	100% 100%	Approved Mfr. drgs. Factory Standard	Approved Mfr. drgs. Factory Standard	Log Book Log Book	2 2	---	---	---	
7.0	Nibbling / Punching	1. Cutout Sizes 2. Deburring	MI MA	Measurement Visual	100% 100%	Approved Mfr. drgs. Approved Mfr. drgs.	Approved Mfr. drgs. Approved Mfr. drgs.	Log Book Log Book	2 2	---	---	---	
8.0	ASSEMBLY Frame Assembly & Sheet fixing	1. Dimensions 2. Alignment 3. Welding Quality 4. Surface defects	MA MA MA MA	Measurement Measurement Visual Visual	100% 100% 100% 100%	Approved drg. / Mfr. Standards Approved drg. / Mfr. Standards Approved drg. / Mfr. Standards Approved drg. / Mfr. Standards	Approved drg. / Mfr. Standards Approved drg. / Mfr. Standards Approved drg. / Mfr. Standards Approved drg. / Mfr. Standards	Log Book Log Book Log Book Log Book	2 2 2 2	---	---	2 2 2 2	

LEGEND: * CR - Critical characteristics
MA - Major characteristics
MI - Minor characteristics

\$ P - Agency Performing the Test.
W - Agency Witnessing the Test.
V - Agency Verifying the Test.

1 - BHEL
2 - Vendor
3 - Sub-vendor



STANDARD QUALITY PLAN FOR LOCAL CONTROL PANEL

STD QUALITY PLAN NO.: PE-QP-999-145-1056

VOLUME IIB

SECTION D

REV. NO. 01 DATE: 22-02-2008

SHEET 4 OF 7

Sl. No.	Component / operation	Characteristics Checked	* Category	Type/Method of Check	Extent of Check	Reference documents	Acceptance Norms	Format of Records	Agency \$			Remarks
									P	W	V	
9.0	Pre-treatment and Painting	<ol style="list-style-type: none"> 1. Pretreatment Process 2. Process parameters like bath temp. concentration etc. 3. Dipping / Removal Time 4. Surface quality after every dip 5. Primer after phosphating 6. Putty Application & Rubbing after primer 7. Paint first coat 8. Putty Application and Rubbing after first coat of paint 9. Paint second coat 	MA	Visual	100%	Factory Standard & Relevant standard	Factory Standard & Relevant standard	Log Book	2	---	1	
			MA	Measurement	Periodic	Factory Standard & Relevant standard	Factory Standard & Relevant standard	Log Book	2	---	1	
			MA	Measurement	100%	Factory Standard & Relevant standard	Factory Standard & Relevant standard	Log Book	2	---	1	
			MA	Visual	100%	Factory Standard & Relevant standard	Factory Standard & Relevant standard	Log Book	2	---	1	
			MA	Visual, Thickness	100%	Factory Standard & Relevant standard	Factory Standard & Relevant standard	Log Book	2	---	1	
			MA	Visual	100%	Factory Standard & Relevant standard	Factory Standard & Relevant standard	Log Book	2	---	1	
			MA	Visual, Thickness	100%	Factory Standard & Relevant standard	Factory Standard & Relevant standard	Log Book	2	---	1	
			MA	Visual	100%	Factory Standard & Relevant standard	Factory Standard & Relevant standard	Log Book	2	---	1	
			MA	Visual, Thickness, Scratch test Colour adhesion	100%	Factory Standard & Relevant standard	Factory Standard & Relevant standard	Log Book	2	---	1	

LEGEND: * CR - Critical characteristics
 MA - Major characteristics
 MI - Minor characteristics

\$ P - Agency Performing the Test.
 W - Agency Witnessing the Test.
 V - Agency Verifying the Test.

1 - BHEL
 2 - Vendor
 3 - Sub-vendor



PEM :: C&I

STANDARD QUALITY PLAN FOR LOCAL CONTROL PANEL

STD QUALITY PLAN NO.: **PE-QP-999-145-1056**
 VOLUME IIB
 SECTION D
 REV. NO. **01** DATE: **22-02-2008**
 SHEET 5 OF 7

Sl. No.	Component / operation	Characteristics Checked	* Category	Type/Method of Check	Extent of Check	Reference documents	Acceptance Norms	Format of Records	Agency \$			Remarks
									P	W	V	
10.	Panel Wiring	1. Wiring Layout 2. Wiring Termination (Crimped Lugs) 3. Ferrule numbers 4. Colour of wiring 5. Size of Conductor	MA	Visual	100%	Approved drgs. & Specs.	Approved drgs. & Specs.	Log Book	2	---	---	
			MA	Visual	100%	Approved drgs. & Specs.	Approved drgs. & Specs.	Log Book	2	---	---	
			MA	Visual	100%	Approved drgs. & Specs.	Approved drgs. & Specs.	Log Book	2	---	---	
			MA	Visual	100%	Approved drgs. & Specs.	Approved drgs. & Specs.	Log Book	2	---	1	
			MA	Measurement	100%	Approved drgs. & Specs.	Approved drgs. & Specs.	Log Book	2	---	1	
11.	Component Mounting	1. Correct components 2. Fixing	MA	Visual	100%	Approved drgs., Specs. & BOM	Approved drgs., Specs. & BOM	Log Book	2	---	---	
			MA	Visual	100%	Approved drgs., Specs. & BOM	Approved drgs., Specs. & BOM	Log Book	2	---	---	
12.	FINAL Final Inspection	1. Workmanship 2. Component layout (neatness, accessibility & safety) Mounting / Proper fixing of all components 3. Components identification Marking / Name plates	MA	Visual	100%	Factory Standard	Factory Standard	Inspection Report	2	1	1	At Random by BHEL, based on 100 % internal test reports by Mfr.
			MA	Visual	100%	BHEL approved drg. / Spec.	BHEL approved drg. / Spec.	Inspection Report	2	1	1	
			MA	Visual	100%	BHEL approved drg. / Spec.	BHEL approved drg. / Spec.	Inspection Report	2	1	1	

LEGEND: * CR - Critical characteristics
 MA - Major characteristics
 MI - Minor characteristics

\$

P - Agency Performing the Test.
 W - Agency Witnessing the Test.
 V - Agency Verifying the Test.

1 - BHEL
 2 - Vendor
 3 - Sub-vendor



PEM :: C&I

STANDARD QUALITY PLAN FOR LOCAL CONTROL PANEL

STD QUALITY PLAN NO.: **PE-QP-999-145-1056**
 VOLUME IIB
 SECTION D
 REV. NO. **01** DATE: **22-02-2008**
 SHEET 6 OF 7

Sl. No.	Component / operation	Characteristics Checked	* Category	Type/Method of Check	Extent of Check	Reference documents	Acceptance Norms	Format of Records	Agency \$			Remarks
									P	W	V	
		5. Dimensions	MA	Measurement	100%	BHEL approved drg. / Spec., BOM	BHEL approved drg. / Spec., BOM	Inspection Report	2	1	1	At Random by BHEL, based on 100 % internal test reports by Mfr.
		6. Door functioning	MA	Functional	100%	BHEL approved drg. / Spec.	BHEL approved drg. / Spec.	Inspection Report	2	1	1	
		7. Paint Shade	CR	Visual	100%	BHEL approved drg. / Spec.	BHEL approved drg. / Spec.	Inspection Report	2	1	1	
		8. Paint Thickness	CR	Measurement	100%	BHEL approved drg. / Spec.	BHEL approved drg. / Spec.	Inspection Report	2	1	1	
		9. Workmanship of Gaskets	MA	Visual	100%	Factory Standard	Factory Standard	Inspection Report	2	1	1	
		10. Wiring Layout	MA	Visual	100%	BHEL approved drg.	BHEL approved drg.	Inspection Report	2	1	1	
		11. Wire Termination	MA	Pulling manually	Sample	----	Firm termination	Inspection Report	2	1	1	
		12. Continuity	MA	Electrical	100%	----	Continuity OK	Inspection Report	2	1	1	

LEGEND:	* CR	- Critical characteristics	\$	P	- Agency Performing the Test.	1	- BHEL
	MA	- Major characteristics		W	- Agency Witnessing the Test.	2	- Vendor
	MI	- Minor characteristics		V	- Agency Verifying the Test.	3	- Sub-vendor

**STANDARD QUALITY PLAN
FOR
LOCAL CONTROL PANEL**

STD QUALITY PLAN NO.: **PE-QP-999-145-1056**

VOLUME **IIB**

SECTION **D**

REV. NO. **01** DATE: **22-02-2008**

SHEET **7** OF **7**

Sl. No.	Component / operation	Characteristics Checked	* Category	Type/Method of Check	Extent of Check	Reference documents	Acceptance Norms	Format of Records	Agency \$			Remarks
									P	W	V	
13.	TYPE TEST	Degree of Protection	CR	Mech. Protection	Sample	BHEL approved spec., drg relevant IEC-60947, IEC-60079	BHEL approved spec., drg relevant IEC-60947, IEC-60079	Type Test Certificate	3	---	1	
14	ROUTINE TEST	IR before & after HV Test	CR	Electrical	100%	BHEL approved spec., drg., BOM & relevant standard	BHEL approved spec., drg., BOM & relevant standard	Test Report	2	1	1	
15	FUNCTIONAL TEST	1. Control Logic Operation 2. Instrument Calibratio 3. Temperature rise	CR	Electrical	100%	BHEL approved spec. / drg.	BHEL approved spec. / drg.	Inspection Report	2	1	1	
			CR	Electrical	10%	BHEL approved spec. / drg.	BHEL approved spec. / drg.	Inspection Report	2	1	1	
			CR	Electrical	100%	BHEL approved spec./drg. & relevant standard	BHEL approved spec/drg & relevant standard	Inspection Report	2	1	1	

LEGEND: * CR - Critical characteristics
 MA - Major characteristics
 MI - Minor characteristics

\$

P - Agency Performing the Test.
 W - Agency Witnessing the Test.
 V - Agency Verifying the Test.

1 - BHEL
 2 - Vendor
 3 - Sub-vendor

	TITLE: TECHNICAL SPECIFICATION FOR CHLORINATION PLANT 1X800 MW TSGENCO KOTHAGUDEM TPS STAGE -VII, PALONCHA	SPEC NO: PE-TS-410-174-A001	
		VOLUME: II-B	
		SECTION: D	
		REV NO: 00	DATE:

DRIVE CONTROL PHILSOPHY

PLC INTERFACE FOR BIDIRECTIONAL DRIVE (WITH INTEGRAL STARTER)

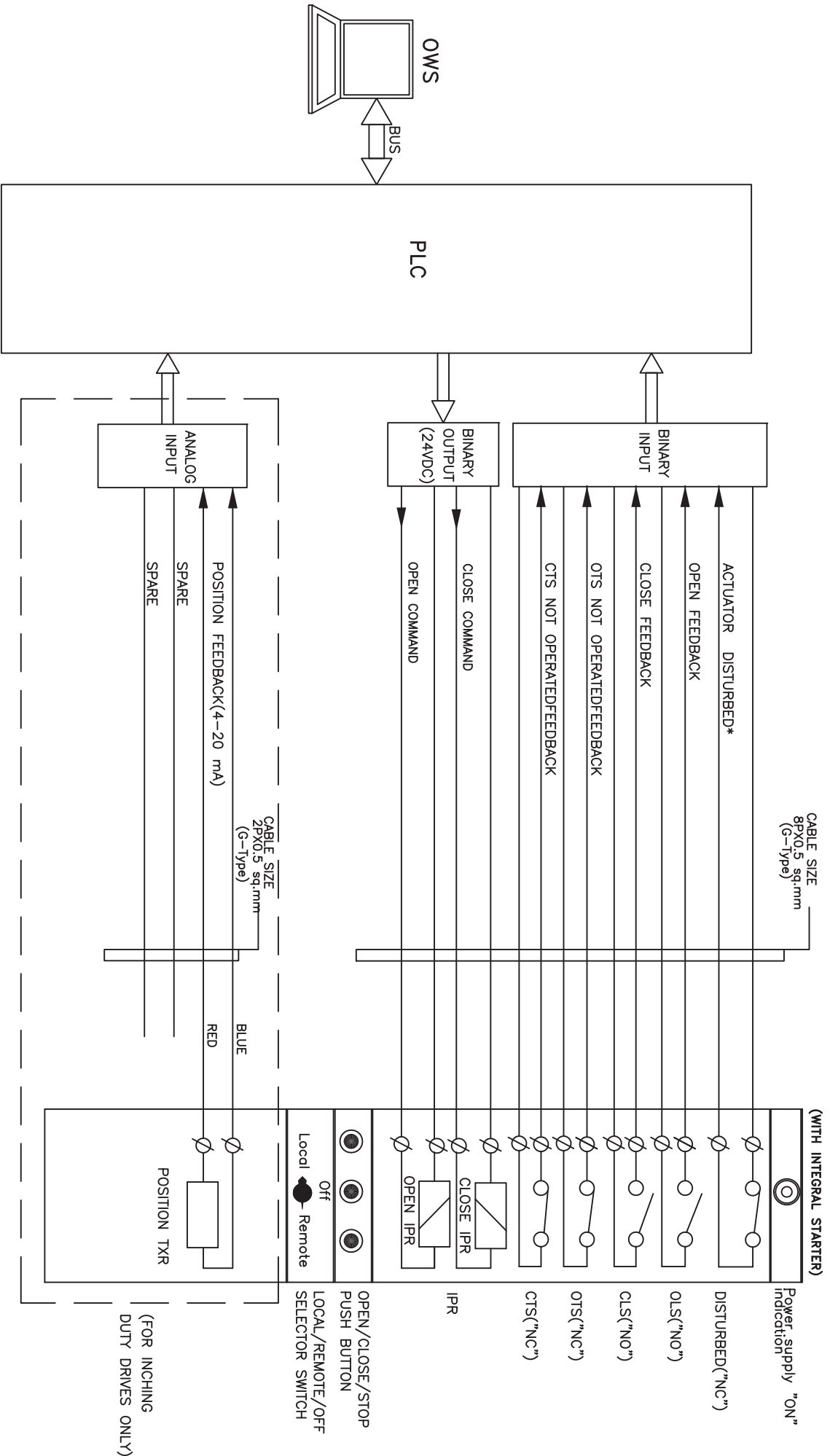

NOTE:

- * DISTURBED= Loss of Power supply (1 Phase/3 Phase)/
- Loss of control supply/ Motor thermostat trip/
- Thermal over load/Torque over/loss of gate mode/
- Local/Off/Remote Sel. switch
- Stop PB optd.

		PROJECT: 1X800 KOTHAGUDEM TPS STAGE-VII, UNIT-12	DRG. NO. PE-DM-410-145-1002
TITLE: PLC INTERFACE FOR BIDIRECTIONAL DRIVE		DATE: 12.03.2015	REV. NO. 00
SHT	7	OF	11

PLC INTERFACE FOR UNIDIRECTIONAL LT DRIVE

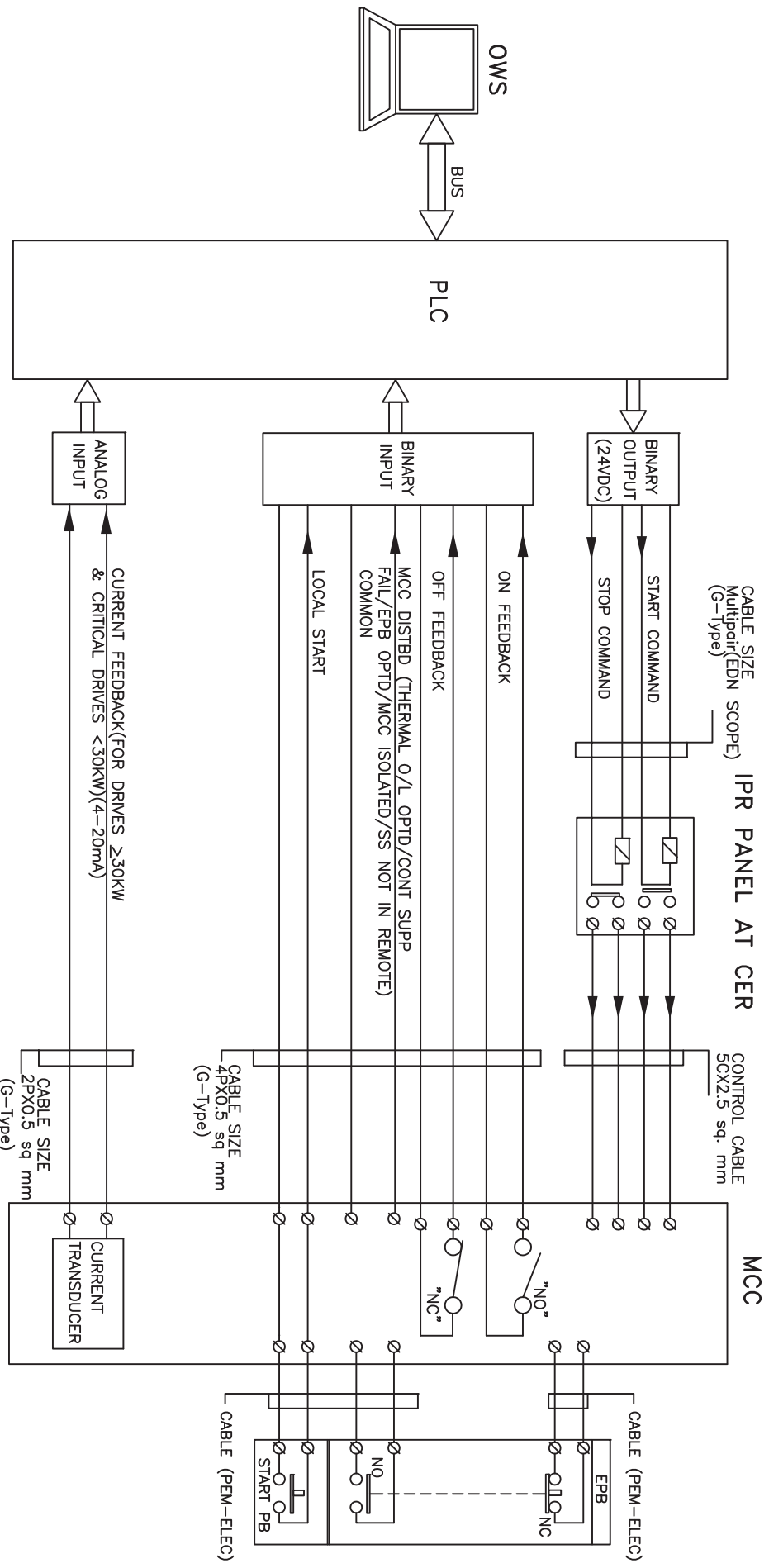

* FOR LTUD DRIVES ALL LUBE OIL PUMPS, SCANNER AIR FANS, SEAL AIR FANS, 4-20mA CURRENT TRANSDUCER SHALL BE CONSIDERED.

	PROJECT:	1X800 KOTHAGUDEM TPS	DRG. NO.	PE-DM-410-145-1002
	TITLE:	STAGE-VII, UNIT-12	DATE	12.03.2015
		PLC INTERFACE FOR UNIDIRECTIONAL LT DRIVE	REV. NO.	00
			SHT	8 OF 11

PLC INTERFACE FOR SOLENOID DRIVE (24V DC / 240V AC UPS)

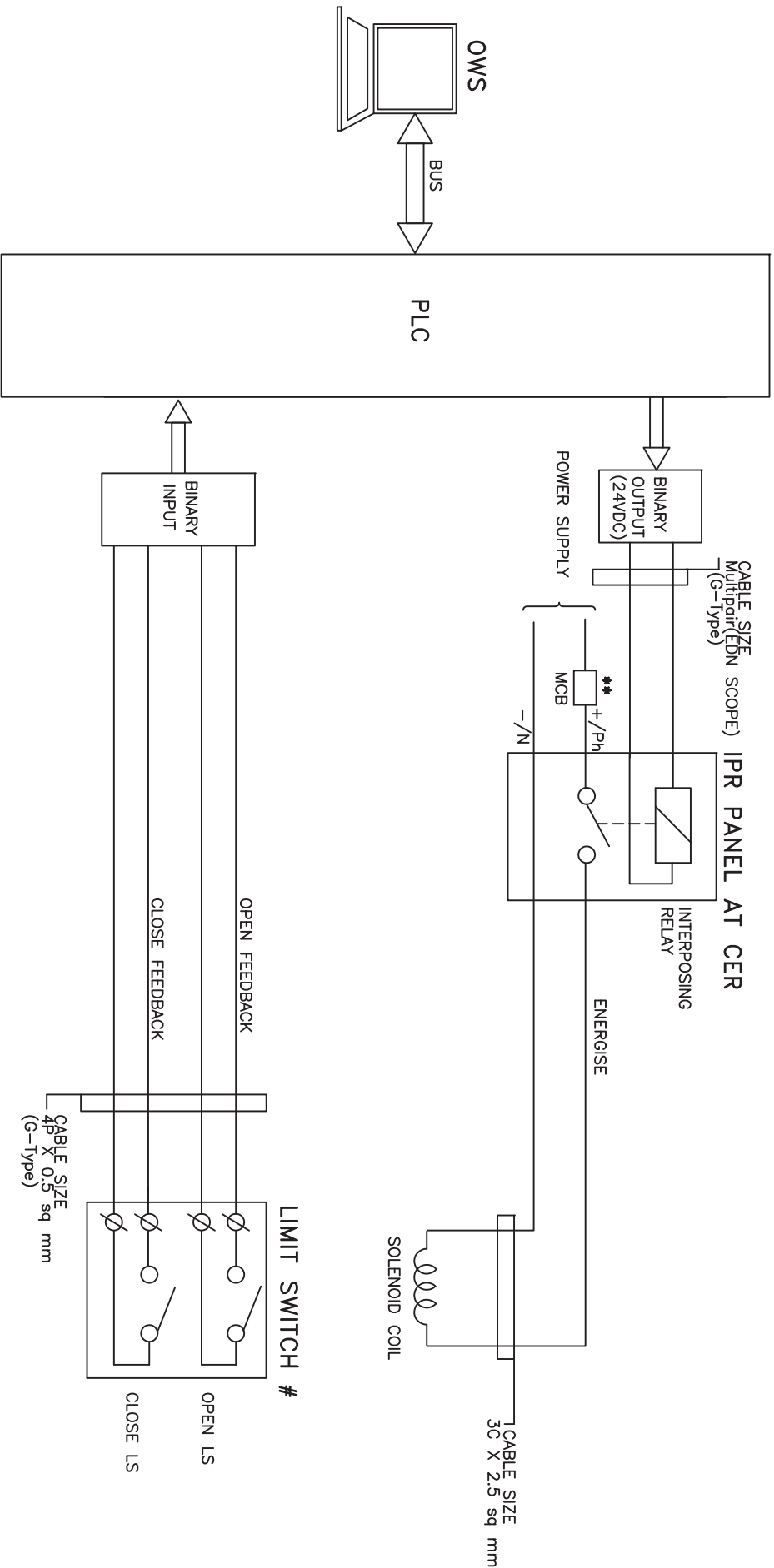

NOTES:

- ** MCB SHALL BE PROVIDED FOR EACH SOLENOID
- # FOR ON/OFF TYPE, SOLENOID ACTUATED CONTROL VALVE.

 MTR Matsushita Company	PROJECT:	1X800 KOTHAGUDEM TPS	DRG. NO.	PE-DM-410-145-1002
	TITLE:	PLC INTERFACE FOR SOLENOID DRIVE (SINGLE COIL)	DATE	12.03.2015
		REV. NO.	00	
		SHT	9	OF 11

PLC INTERFACE FOR SOLENOID DRIVE (24V DC / 240V AC UPS)

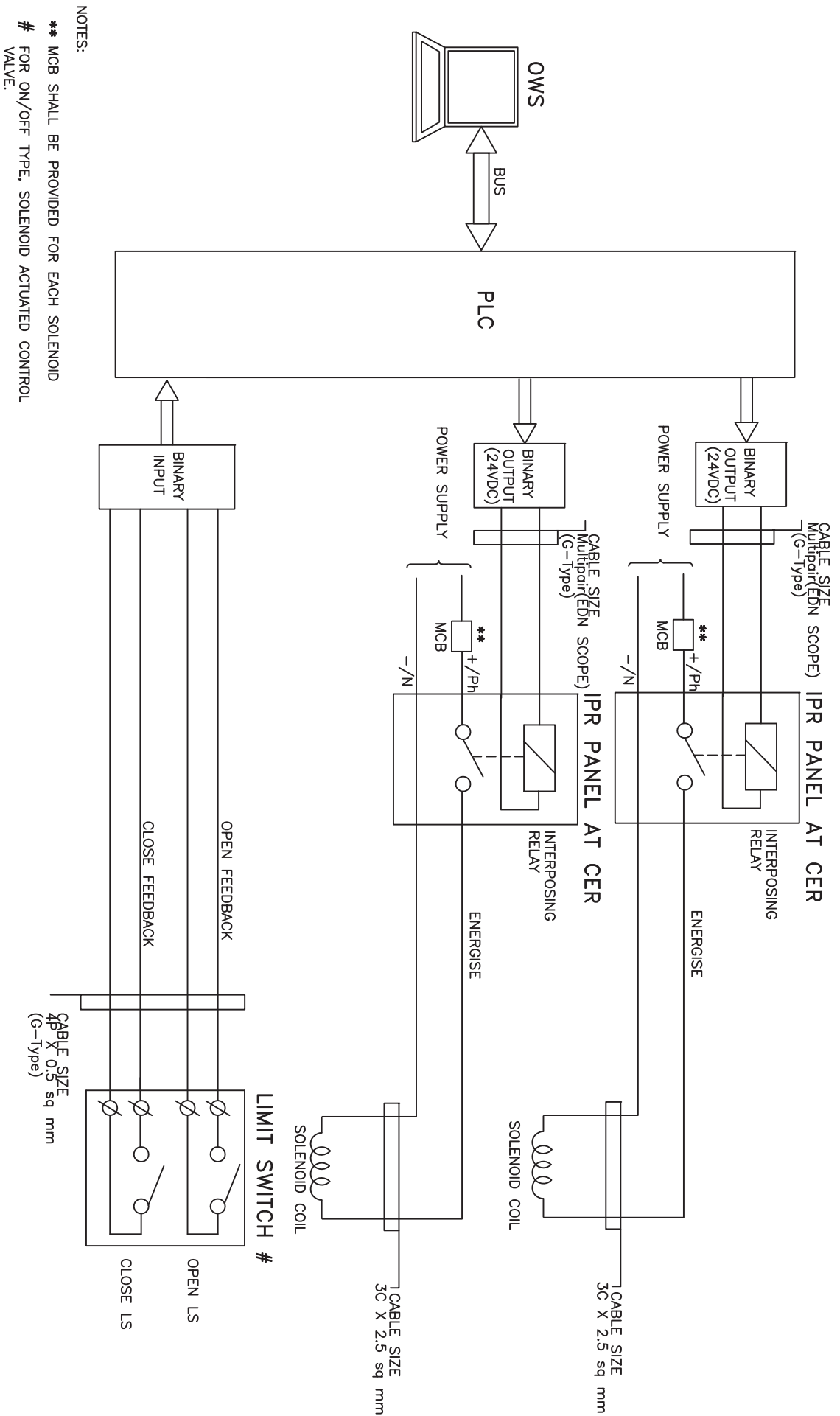

 MTR Matsushita Company	PROJECT:	1X800 KOTHAGUDEM TPS
	TITLE:	STAGE-VII, UNIT-12
	PLC INTERFACE FOR	
	SOLENOID DRIVE (DOUBLE COIL)	
DRG. NO.	PE-DM-410-145-1002	
DATE	12.03.2015	
REV. NO.	00	
SHT	9a	OF 11

PLC INTERFACE FOR ANALOG DRIVE (WITH SMART POSITIONER)

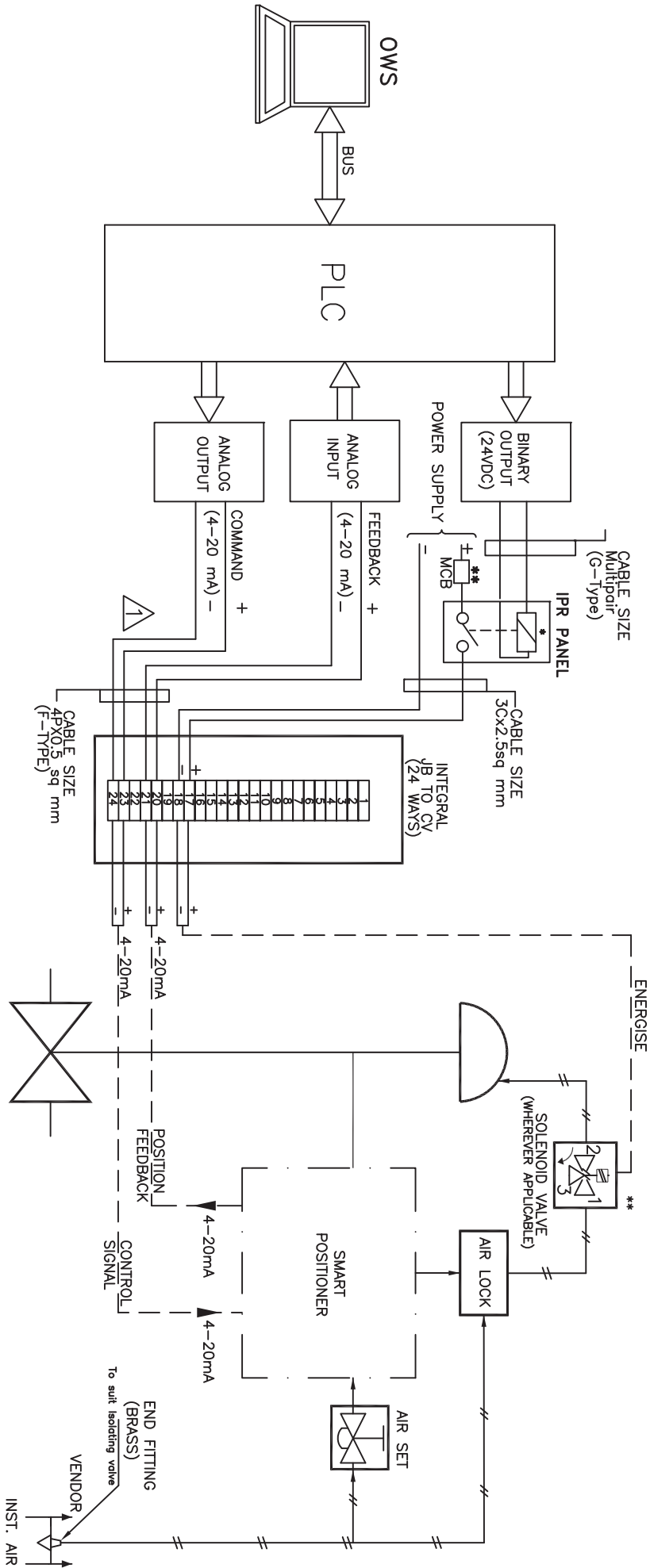

NOTES:

** APPLICABLE TO VALVES WHERE PROTECTION OPEN/CLOSE ACTION FOR CONTROL DEMAND OVERRIDING IS REQUIRED.

PROJECT:		1X800 KOTHAGUDEM TPS		DRG. NO.	PE-DM-410-145-1002
TITLE:		STAGE-VII, UNIT-12		DATE	12.03.2015
		TYPICAL HOOK-UP DIAGRAM		REV. NO.	00
		ANALOG DRIVE (WITH SMART POSITIONER)		SHT	11 OF 11



	TITLE: TECHNICAL SPECIFICATION FOR CHLORINATION PLANT 1X800 MW TSGENCO KOTHAGUDEM TPS STAGE -VII, PALONCHA	SPEC NO: PE-TS-410-174-A001	
		VOLUME: II-B	
		SECTION: D	
		REV NO: 00	DATE:

ACTUATOR DETAILS



Technical specification for
CONTROL & INSTRUMENTATION

1X800 MW KOTHAGUDEM

SPEC NO.: **PE-TS-410-145-I**

VOLUME

SECTION

REV. NO. 00

DATE : 10.03.2015

SHEET OF

ACTUATOR SPECIFICATION

VOLUME: V-A

SECTION-III

**TECHNICAL SPECIFICATION
FOR
ELECTRIC MOTOR ACTUATORS**

1.00.00 SCOPE

1.01.00 This Section covers the general requirements of Electric Motor Actuators for valves/dampers.

1.02.00 All electric motor actuators shall be furnished in accordance with this general specification and the accompanying driven equipment specification. All the electrical actuators shall be INTEGRAL type only.

2.00.00 STANDARDS

2.01.00 All electrical equipment shall conform to the latest applicable IS, ANSI and NEMA Standards, except when stated otherwise herein or in driven equipment specification.

2.02.00 Major standards, which shall be followed, are listed below. Other applicable Indian Standards for any component part even if not covered in the listed standards shall also be followed

i) IS -9334

ii) IS-325

3.00.00 SERVICE CONDITIONS

3.01.00 The actuator shall be suitable for operation in hot, humid and tropical atmosphere, highly polluted at places with coal dust and/or fly ash.

3.02.00 Unless otherwise noted, electrical equipment/system design shall be based on the service conditions and auxiliary power supply given in the general specification.

3.03.00 For actuator motor installed outdoor and exposed to direct sun rays, the effect of solar heat shall be considered in the determination of the design ambient temperature.

4.00.00 RATING

4.01.00 For isolating service, the actuator shall be rated for three successive open-close operation of the valve/damper or 15 minutes, whichever is longer.

4.02.00 For regulating service, the actuator shall be suitably time-rated for the duty cycle involved with necessary number of starts per hour, but in no case less than 150 starts per hour.

5.00.00 **PERFORMANCE**

The actuator shall meet the following performance requirements:

- 5.01.00 Open and close the valve completely and make leak-tight valve closure without jamming.
- 5.02.00 Attain full speed operation before valve load is encountered and imparts an unseating blow to start the valve in motion (hammer blow effect).
- 5.03.00 Operate the valve stem at standard stem speed and shall function against design differential pressure across the valve seat.
- 5.04.00 The motor reduction gearing shall be sufficient to lock the shaft when the motor is de-energised and prevent drift from torque switch spring pressure.
- 5.05.00 The entire mechanism shall withstand shock resulting from closing with improper setting of limit switches or from lodging of foreign matter under the valve seat.

6.00.00 **SPECIFIC REQUIREMENT**

6.01.00 **Construction**

- 6.01.01 The actuator shall essentially comprise the drive motor, torque/ limit switches, gear train, clutch, hand wheel, position indicator/ transmitter, in-built thermostat for over load protection, space heater and internal wiring.
- 6.01.02 The actuator enclosure shall be totally enclosed, dust tight, weather-proof suitable for outdoor use without necessity of any canopy. Degree of protection of enclosure for motor actuator shall be IP-65.
- 6.01.03 All electrical equipment, accessories and wiring shall be provided with tropical finish to prevent fungus growth.
- 6.01.04 The actuator shall be designed for mounting in any position without any lubricant leakage or operating difficulty.

6.02.00 **Motor**

- 6.02.01 The drive motor shall be three phase, squirrel cage, induction machine with minimum class B insulation and IPW-55 enclosure, designed for high torque and reversing service. Canopy shall be provided for outdoor service.
- 6.02.02 The motor shall be designed for full voltage direct on-line start, with starting current limited to 6 times full-load current.
- 6.02.03 The motor shall be capable of starting at 85 percent of rated voltage and running at 80 percent of rated voltage at rated torque and 85 percent rated voltage at 33 percent excess rated torque for a period of 5 minutes each.
- 6.02.04 Motor leads shall be terminated in the limit switch compartment.
- 6.02.05 Motor actuators for valves/dampers shall be with integral starter with 3phase/3wire, 415V AC and operable from remote.

- 6.02.06 Earthing terminals shall be provided on either side of the motor.
- 6.03.00 **Limit Switches**
- Each actuator shall be provided with following limit switches: -
- 6.03.01 2 torque limit switches, one for each direction of travel, self-locking, adjustable torque type.
- 6.03.02 4 end-of-travel limit switches, two for each direction of travel.
- 6.03.03 2 position limit switches, one for each direction of travel, each adjustable at any position from fully open to fully closed positions of the valve/damper.
- 6.03.04 Each limit switch shall have 2 NO + 2 NC potential free contacts. Contact rating shall be 5A at 240V A.C. or 0.5A at 220V D.C.
- 6.04.00 **Hand Wheel**
- Each actuator shall be provided with a hand wheel for emergency manual operation. The hand wheel shall de-clutch automatically when the motor is energized.
- 6.05.00 **Position Indicator/Transmitter**
- The actuator shall have:
- 6.05.01 One (1) built-in local position indicator for 0-100% travel.
- 6.05.02 One (1) position transmitter, 4-20 mA current signal as position feedback, for remote indicator.
- 6.06.00 **Space Heater**
- A space heater shall be included in the limit switch compartment suitable for 240V, 1 phase, 50 Hz supply.
- 6.07.00 **Wiring**
- All electrical devices shall be wired up to and terminated in a terminal box. All wiring shall be done with 1100 V grade fire resistance PVC insulated stranded copper conductor of not less than 2.5 Sq.mm cross section. All wiring shall be identified at both ends with ferrules. All the electrical actuators shall have uniform wiring.
- 6.08.00 **Terminal Box**
- The terminal box shall be weather proof, with removable front cover and cable glands for cable connection. The terminal shall be suitable for connection of 2.5 Sq.mm copper conductor.
- 7.00.00 **ACCESSORIES**

As required for the driven equipment, the actuator shall be furnished with starting equipment mounted on the actuator. This shall include:

- 7.01.00 One (1) triple pole MCCB
- 7.02.00 One (1) reversing starter with mechanically interlocked contactors, 3 thermal overload relays, 2 NO + 2 NC auxiliary contacts for each contactor.
- 7.03.00 One (1) remote-local selector switch.
- 7.04.00 CLOSE-STOP-OPEN oil tight push buttons with indication lights.
- 7.05.00 415/240 V control transformer with primary & secondary fuses.

8.00.00 **TEST**

The actuator and all components thereof shall be subject to tests as per relevant Standards. In addition, if any special test is called for in equipment specification, the same shall be performed.

9.00.00 **DRAWINGS, DATA & MANUALS**

- 9.01.00 Drawings, Data & Manuals shall be submitted in triplicate with the bid and in quantities and procedures as specified in General Conditions of Contract and/or elsewhere in the specification for approval and subsequent distribution after the issue of 'Letter of Intent'.

9.02.00 **To be submitted with Bid**

Data sheet for each type of actuator shall be furnished along with internal wiring diagram, suggested control schematic and torque limit switch contact development and manufacturer's catalogues. Drawings, Data & Manuals shall be submitted in triplicate with the bid and in quantities and procedures as specified in General Conditions of Contract and/or elsewhere in the specification for approval and subsequent distribution after the issue of 'Letter of Intent'.

9.03.00 **To be submitted for Owner / Purchaser's Approval and Distribution**

All relevant drawings and data pertaining to the equipment like GTP, GA drawing, foundation plan, BOM, control & schematics, QAP, etc. shall be submitted by the Bidder for approval of Owner/Owner's consultant. Also refer clause no. 1.19.02(u) of Section-I of Volume – V-A : Technical Specifications for Electrical Equipment & Accessories.

ANNEXURE-A

DESIGN DATA

1.0 AUXILIARY POWER SUPPLY

S	upply	Description	Consumer
	L.V. Supply (i)	415V, 3Ø, 3W, 50 Hz Effectively earthed Fault level 50 kA symm. for 1 sec.	u Motors above 0.2kW pto less than 175kW.
	(ii)	240V AC/415V AC 240V, 1Ø, 2W, 50 Hz effectively earthed	Motors upto 0.2kW. o Lighting, Space heat- ing , A.C supply for Contr- l & protective devices.
	D.C. Supply	220V, 2W, unearthed Fault level 25* kA. for 1 sec.	& D.C. alarm, control protective devices

* Indicative only, the actual value will be decided by the Bidder, after substantiating the same by calculation.

2.0 RANGE OF VARIATION

A.C. Supply :

V	voltage	:	± 10%
	Frequency	:	+3% to -5%.
	Combined Volt + frequency	:	10% (absolute sum)

During starting of large motor, the voltage may drop to 80% of the rated voltage for a period of 60 seconds. All electrical equipment while running shall successfully ride over such period without affecting system performance.

D.C. Supply :

Voltage	:	187 to 242
---------	---	------------



Technical specification for
CONTROL & INSTRUMENTATION

1X800 MW KOTHAGUDEM

SPEC NO.: **PE-TS-410-145-I**

VOLUME

SECTION

REV. NO. 00

DATE : 10.03.2015

SHEET OF

Actuator Data Sheet

	SPECIFICATION FOR MOTORISED VALVE ACTUATOR		SPECIFICATION NO.:			
			VOLUME			
			SECTION			
			REV. NO.	00	DATE:	06.01.2015
			SHEET	1	OF	3
Data Sheet A & B						
DATA SHEET-A (TO BE FILLED BY PURCHASER)			DATA SHEET-B (TO BE FILLED-UP BY BIDDER)			
GENERAL*	* PROJECT	1 X 800 MW KOTHAGUDAM TPS				
	OFFER REFERENCE					
	* TAG NO. SERVICE					
	* DUTY	<input type="checkbox"/> ON / OFF	<input type="checkbox"/> INCHING			
	* LINE SIZE (inlet/outlet): MATERIAL					
	* VALVE TYPE	<input type="checkbox"/> GLOBE <input type="checkbox"/> GATE <input type="checkbox"/> REG. GLOBE <input type="checkbox"/> BUTTERFLY				
	* OPENING / CLOSING TIME					
	* WORKING PRESSURE					
	AMBIENT CONDITION	SHALL BE SUITABLE FOR CONTINUOUS OPERATION UNDER AN AMBIENT TEMP. OF 0-55 DEG C AND RELATIVE HUMIDITY OF 0-95%				
	VALVE SEAT TEST PRESS	BIDDER TO SPECIFY				
	REQUIRED VALVE TORQUE	BIDDER TO SPECIFY				
	ACTUATOR RATED TORQUE	BIDDER TO SPECIFY				
CONSTRUCTION AND SIZING	CONSTRUCTION	TOTALLY ENCLOSED, DUST TIGHT, WEATHER PROOF, SUITABLE FOR OUTDOOR USE WITHOUT CANOPY, IP:65				
	MECHANICAL POSITION INDICATOR	TO BE PROVIDED FOR 0-100% TRAVEL				
	BEARINGS	DOUBLE SHIELDED, GREASE LUBRICATED ANTI-FRICTION.				
	GEAR TRAIN FOR LIMIT SWITCH/TORQUE SWITCH OPERATION	METAL (NOT FIBRE GEARS). SELF-LOCKING TO PREVENT DRIFT UNDER TORQUE SWITCH SPRING PRESSURE WHEN MOTOR IS DE-ENERGIZED.				
	SIZING	OPEN/CLOSE AT RATED SPEED AGAINST DESIGNED DIFFERENTIAL PRESSURE AT 90% OF RATED VOLTAGE. FOR ISOLATING SERVICE THREE SUCCESSIVE OPEN-CLOSE OPERATIONS OR 15 MINS. WHICHEVER IS HIGHER. FOR REGULATING SERVICE - 150 STARTS/HR MINIMUM				
HANDWHEEL	* REQUIRED	<input checked="" type="checkbox"/> YES	<input type="checkbox"/> NO			
	* ORIENTATION	<input type="checkbox"/> TOP MOUNTED	<input type="checkbox"/> SIDE MOUNTED			
	*TO DISENGAGE AUTOMATICALLY DURING MOTOR OPERATION.					
ELECTRIC ACTUATOR	ACTUATOR MAKE/MODEL	BIDDER TO SPECIFY				
	MOTOR MAKE / MODEL / TYPE / RATING (KW)	BIDDER TO SPECIFY				
	@ MOTOR TYPE	SQUIRREL CAGE INDUCTION MOTOR, STARTING CURRENT LIMITED TO SIX TIMES THE RATED CURRENT-INCLUSIVE OF I.S. TOLERANCE				
	ACTUATOR APPLICABLE WIRING DIAGRAM	<input checked="" type="checkbox"/> ENCLOSED <input checked="" type="checkbox"/> DRG. NO. 3-V-MISC-24227 R00 (INDICATIVE)				
	COLOUR SHADE	<input checked="" type="checkbox"/> BLUE (RAL 5012), To be decided during detail engg.				
	PAINT TYPE (## Refer Notes)	<input type="checkbox"/> ENAMEL	<input checked="" type="checkbox"/> EPOXY	<input type="checkbox"/>		
	SHAFT RPM	BIDDER TO SPECIFY				
	OLR SET VALUE	BIDDER TO SPECIFY				
	@ STARTING / FULL LOAD CURRENT	BIDDER TO SPECIFY				
	NO. OF REV FOR FULL TRAVEL	BIDDER TO SPECIFY				
	@ PWR SUPP TO MTR / STARTER	415V, 3PH, AC, 3 WIRE				
	@ CONTROL VOLTAGE REQUIREMENT	TO BE DERIVED FROM THE POWER SUPPLY TO THE STARTER <input type="checkbox"/> 230 V <input type="checkbox"/> 110 V				
	@ ENCLOSURE CLASS OF MOTOR	<input type="checkbox"/> IP 65	<input type="checkbox"/> FLAME PROOF			

	SPECIFICATION FOR MOTORISED VALVE ACTUATOR		SPECIFICATION NO.:		
			VOLUME		
			SECTION		
	REV. NO.	00	DATE:	06.01.2015	
	SHEET	2	OF	3	
Data Sheet A & B					
DATA SHEET-A (TO BE FILLED BY PURCHASER)			DATA SHEET-B (TO BE FILLED-UP BY BIDDER)		
INTEGRAL STARTER	@ INSULATION CLASS	CLASS-F TEMP. RISE LIMITED TO CLASS-B			
	@ WINDING TEMP PROTECTION	<input checked="" type="checkbox"/> THERMOSTAT (3 Nos.,1 IN EACH PHASE) <input type="checkbox"/> _____			
	SINGLE PHASE / WRONG PHASE SEQUENCE PROTECTION	REQUIRED			
	INTEGRAL STARTER	<input checked="" type="checkbox"/> REQUIRED <input type="checkbox"/> NOT REQUIRED			
	TYPE OF SWITCHING DEVICE	<input checked="" type="checkbox"/> CONTACTORS <input type="checkbox"/> THYRISTORS			
	TYPE	<input checked="" type="checkbox"/> CONVENTIONAL <input type="checkbox"/> SMART (NON-INTRUSIVE)			
	IF SMART	NOT APPLICABLE			
	a) SERIAL LINK INTERFACE	<input type="checkbox"/> INTEGRAL <input type="checkbox"/> FIELD MOUNTED			
	b) SERIAL LINK PROTOCOL	<input type="checkbox"/> FOUNDATION FIELD-BUS <input type="checkbox"/> PROFI-BUS <input type="checkbox"/> DEVICE NET <input type="checkbox"/>			
	c) SERIAL LINK MEDIA	<input type="checkbox"/> TWISTED PAIR Cu-CBL <input type="checkbox"/> CO-AXIAL Cu-CBL <input type="checkbox"/> OFC			
	d) HAND HELD PROGRAMMER	<input type="checkbox"/> REQUIRED <input type="checkbox"/> NOT REQUIRED			
	e) TYPE OF HAND HELD PROGRAMMER	<input type="checkbox"/> BLUETOOTH <input type="checkbox"/> INFRARED <input type="checkbox"/>			
	f) MASTER STATION	<input type="checkbox"/> REQUIRED <input type="checkbox"/> NOT REQUIRED			
	g) MASTER STN INTRFACE WITH DCS	<input type="checkbox"/> MODBUS <input type="checkbox"/> TCP/IP			
	h) DETAILS OF SPECIAL CABLE	<input type="checkbox"/> ENCLOSED <input type="checkbox"/> NOT REQUIRED			
	STEP DOWN CONT. TRANSFORMER	<input checked="" type="checkbox"/> REQUIRED			
OPEN / CLOSE PB	<input checked="" type="checkbox"/> REQUIRED <input type="checkbox"/> NOT REQUIRED				
STOP PB	<input checked="" type="checkbox"/> REQUIRED <input type="checkbox"/> NOT REQUIRED				
INDICATING LAMPS	<input checked="" type="checkbox"/> REQUIRED <input type="checkbox"/> NOT REQUIRED				
LOCAL REMOTE S/S	<input checked="" type="checkbox"/> REQUIRED <input type="checkbox"/> NOT REQUIRED				
STATUS CONTACTS FOR MONITORING	<input checked="" type="checkbox"/> REQUIRED <input type="checkbox"/> NOT REQUIRED				
INTEGRAL STARTER DISTURBED SIGNAL	REQUIRED (O/L RELAY OPERATED, CONT. /POWER SUPPLY FAILED, S/S IN LOCAL, TORQUE SWITCH OPTD. MID WAY)				
INTERPOSING RELAY/OPTO COUPLER (Applicable for integral Starter)	TYPE OF ISOLATING DEVICE	<input checked="" type="checkbox"/> INTERPOSING RELAY <input type="checkbox"/> OPTO COUPLER <input type="checkbox"/> EITHER			
	QUANTITY	<input type="checkbox"/> 2 NOs. <input checked="" type="checkbox"/> 3 NOs.			
	DRIVING VOLTAGE	<input checked="" type="checkbox"/> 20.5 – 24V DC <input type="checkbox"/> _____ V DC			
	DRIVING CURRENT	<input checked="" type="checkbox"/> 125mA MAX <input type="checkbox"/> _____ mA MAX			
	LOAD RESISTANCE	<input checked="" type="checkbox"/> > 192 ohms - <25 k ohms <input type="checkbox"/> > _____ ohms - < _____ ohms			
TORQUE SWITCH (Not Applicable for Smart Actuator) (\$\$ Refer Notes)	MFR & MODEL NO.	BIDDER TO SPECIFY			
	OPEN / CLOSE	<input checked="" type="checkbox"/> 1 No. <input type="checkbox"/> 2Nos. / <input checked="" type="checkbox"/> 1 No. <input type="checkbox"/> 2Nos			
	CONTACT TYPE	2 NO + 2 NC			
	RATING	5A 240V AC AND 0.5A 220V DC			
	CALIBRATED KNOBS(OPEN&CLOSE TS)	REQUIRED FOR SETTING DESIRED TORQUE			
	ACCURACY	+3% OF SET VALUE			
LIMIT SWITCH (Not Applicable for Smart Actuator) (\$\$ Refer Notes)	MFR & MODEL NO.	BIDDER TO SPECIFY			
	OPEN : INT : CLOSE	<input type="checkbox"/> 1 No <input checked="" type="checkbox"/> 2 Nos. 2 Nos. (ADJ.) <input type="checkbox"/> 1 No. <input checked="" type="checkbox"/> 2Nos.			
	CONTACT TYPE	2 NO + 2 NC			
	RATING (AC / DC)	5A 240V AC AND 0.5A 220V DC			

	SPECIFICATION FOR MOTORISED VALVE ACTUATOR		SPECIFICATION NO.:			
			VOLUME			
			SECTION			
			REV. NO.	00	DATE:	06.01.2015
			SHEET	3	OF	3
Data Sheet A & B						
DATA SHEET-A (TO BE FILLED BY PURCHASER)			DATA SHEET-B (TO BE FILLED-UP BY BIDDER)			
POSITION TRANSMITTER	POSITION TRANSMITTER	<input checked="" type="checkbox"/> REQUIRED <input type="checkbox"/> NOT REQUIRED				
	MFR & MODEL NO.	BIDDER TO SPECIFY				
	TYPE	<input type="checkbox"/> ELECTRONIC (2 WIRE) R/I CONVERTER <input checked="" type="checkbox"/> ELECTRONIC (2 WIRE) CONTACTLESS				
	SUPPLY	<input checked="" type="checkbox"/> 24V DC <input type="checkbox"/>				
	OUTPUT	<input checked="" type="checkbox"/> 4-20mA				
	ACCURACY	± 1% FS				
SPACE HEATER	@SPACE HEATER	REQUIRED				
	@ POWER SUPPLY (NON INTEGRAL)	240V AC, 1 PH., 50 Hz				
	@ POWER SUPPLY (INTEGRAL)	240V AC , 1 PH/415/240 V CTRL TRANSFORMER WITH PRIMARY AND SECONDARY FUSES				
	@ RATING					
TERMINAL BOX	ACTUATOR/MOTOR TERMINAL BOX	REQUIRED				
	ENCL CLASS ACTUATOR/MOTOR T.B.	@ <input type="checkbox"/> IP 68 @ <input type="checkbox"/>				
	@ EARTHING TERMINAL	REQUIRED				
	PLUG & SOCKET(9 PIN) (FOR COMM, LS/TS FEED BACK, PoT)	<input type="checkbox"/> REQUIRED <input checked="" type="checkbox"/> NOT REQUIRED <input type="checkbox"/> 2 NOS. <input type="checkbox"/>				
CABLE GLANDS	@ POWER CABLE GLAND	SIZE:-----				
	@ SPACE HEATER CABLE GLAND	SIZE:-----				
	OTHER CONTROL CABLE GLANDS-1	<input type="checkbox"/> 1No. for BFV of CW PUMP(Cable size 2Px1.5mm2)				
	OTHER CONTROL CABLE GLANDS-2	QUANTITY & SIZE: 1no., 2.5 sq. mm				
WEIGHT	TOTAL WEIGHT (ACTUATOR + ACCESSORIES)	BIDDER TO SPECIFY		_____ Kg.		
NOTES: 1. SCOPE: DESIGN, MANUFACTURE, INSPECTION, TESTING AND DELIVERY TO SITE OF ELECTRIC ACTUATOR FOR INCHING OR OPEN / CLOSE DUTY. 2. CODES & STANDARDS: DESIGN AND MATERIALS USED SHALL COMPLY WITH THE RELEVANT LATEST NATIONAL AND INTERNATIONAL STANDARD. AS A MINIMUM, THE FOLLOWING STANDARDS SHALL BE COMPLIED WITH: IS-9334, IS-2147, IS-2148, IS-325, IS-2959, IS-4691 AND IS-4722 3. TEMPERATURE RISE SHALL BE RESTRICTED TO 70 DEG. C FOR AMBIENT TEMPERATURE OF 50 DEG C. 4. CABLE GLANDS OF DOUBLE COMPRESSION TYPE, BRASS MATERIAL, WITH NICKEL COATING SHALL BE PROVIDED. 5. THE TORQUE SWITCHES SHALL BE PROVIDED WITH MECHANICAL LATCHING DEVICE TO PREVENT OPERATION WHEN UNSEATING FROM THE END POSITIONS. THE LATCHING DEVICE SHALL UNLATCH AS SOON AS THE VALVE LEAVES THE END POSITION. IF SUCH PROVISION IS NOT POSSIBLE, THE TORQUE SWITCHES SHALL BE BYPASSED BY END-POSITION LIMIT SWITCHES WHICH OPENS ON VALVE LEAVING END POSITION. THESE LIMIT SWITCHES ARE ADDITIONAL TO THE NUMBER OF LIMIT SWITCHES SPECIFIED ELSEWHERE. 6. THE MOTOR SHALL OPERATE SATISFACTORILY UNDER THE +/- 10% SUPPLY VOLTAGE VARIATION AT RATED FREQUENCY. -5% TO +3% VARIATION IN FREQUENCY AT RATED SUPPLY VOLTAGE, SIMULTANEOUS VARIATION IN VOLTAGE & FREQUENCY THE SUM OF ABSOLUTE PERCENTAGE NOT EXCEEDING 10%. 7. THE MOTOR SHALL BE SUITABLE FOR DIRECT ON LINE STARTING. \$\$ TORQUE SWITCH & LIMIT SWITCH SHALL ACT INDEPENDENT OF EACH OTHER. TANDEM OPERATION IS NOT ACCEPTABLE. ## EPOXY PAINT IS RECOMMENDED FOR COASTAL AREAS.						
			VENDOR COMPANY SEAL			
			NAME			
			SIGNATURE			
			DATE			
NOTES* = TO BE FILLED BY MPL (LEAD AGENCY), @= TO BE FILLED BY ES						

	TITLE: TECHNICAL SPECIFICATION FOR CHLORINATION PLANT 1X800 MW TSGENCO KOTHAGUDEM TPS STAGE -VII, PALONCHA	SPEC NO: PE-TS-410-174-A001	
		VOLUME: II-B	
		SECTION: D	
		REV NO: 00	DATE:

CABLE BOQ

CABLE SIZES FOR 1X800 MW KOTHAGUDEM TPS	
Sl no.	Cable Type
	G-TYPE
1	2P X 0.5 sqmm
2	4P X 0.5 sq mm
3	8P X 0.5 sqmm
4	12P X 0.5 sqmm
5	2P X 1.5 sqmm
	F-TYPE
1	4P X 0.5 sqmm
2	8P X 0.5 sqmm
3	12P X 0.5 sqmm
4	20P X 0.5 sqmm
	CONTROL CABLE
1	3C X 2.5 sqmm
2	5C x 2.5 sq mm
3	12C x 2.5 sqmm

	TITLE: TECHNICAL SPECIFICATION FOR CHLORINATION PLANT 1X800 MW TSGENCO KOTHAGUDEM TPS STAGE -VII, PALONCHA	SPEC NO: PE-TS-410-174-A001	
		VOLUME: II-B	
		SECTION: D	
		REV NO: 00	DATE:

KKS PHILOSOPHY

	DOCUMENT TITLE
	KKS NUMBERING PHILOSOPHY

1X800MW KOTHAGUDEM

KKS NUMBERING PHILOSOPHY

For identifying (tagging) an instrument / equipment in Power plant KKS numbering scheme is used. The purpose is to assign a unique number to every equipment in the power plant. For C&I equipment unique number are to be provided up to the signal level so that a unique number Input / Output exist in DCS for every signal.

Normally KKS number is a 10 digit alpha-numeric code and is typically split into the following:

X	X	X	AAY			YBB		
---	---	---	-----	--	--	-----	--	--

First three digits indicate the Sub-System. The Code for the major system are given as per **Annexure-1**.

Fourth and Fifth digits are the **Numerical Keys at System Code Level** and used to distinguish between main systems having same Alpha Codes.

Sixth and Seventh digits are the **Equipment / Apparatus / Measuring Circuit Code**. The code of various Equipment / Apparatus / Measuring Circuit is shown in **Annexure-2**

Eight, Nine and tenth digits are the **Numerical Keys at Equipment / Apparatus / Measuring Circuit Code** and used to distinguish between various instruments in the same sub-group. Numerical keys at System / Equipment / Apparatus / Measuring Circuit is shown in **Annexure-3**.

	DOCUMENT TITLE
	KKS NUMBERING PHILOSOPHY
1X800 MW KOTHAGUDEM	

ANNEXURE-1

List of System / Sub-System Codes used in Power Plant:

- 1) Compressed air system : QEA, QEC
- 2) Ventilation System : SAA TO SAZ
- 3) Fire Detection & Protection System + Fire Water pumps : SGM, SGN, SGO, SGP
- 4) Sewage Treatment : SJA TO SJZ
- 5) Pre-treatment Plant : GBI, GBM, GBV
- 6) RO DM Plant : GCI, GCM, GBV

ANNEXURE-2

Standard Equipment Codes:

AA	Valves including drives, also hand operated
AB	Seclusions, Lock, Gates, Doors
AC	Heat Exchanger
AE	Turning, Driving, Lifting equipment
AF	Continuous conveyors, Feeders
AG	Generator Units
AH	Heating and Cooling Units
AK	Pressing and Packaging equipment
AM	Mixer, Stirrer
AN	Blower, Air Pumps / Fans, Compressor Units
AP	Pump Units
AT	Purification, Drying, Filter
AV	Combustion Equipment e.g. grates

Standard Apparatus Codes:

BB	Vessels and Tank
BF	Foundation
BG	Boiler Heating Surfaces
BN	Injector, Ejector
BP	Flow and throughput limitation equipment (Orifice)
BQ	Holder, Carrying Equipment, Support
BR	Piping, Ducts, Chutes, Compensator
BS	Sound Absorber
BU	Insulations, Sheatings

**Standard Measuring Circuits Codes:**

CD	Density
CE	Electrical Quantities
CF	Flow, throughput
CG	Distance, Length, Position
CK	Time
CL	Level
CM	Humidity
CQ	Analysis (SWAS)
CS	Speed, Velocity, Frequency
CT	Temperature
CY	Vibration, Expansion

ANNEXURE-3**Numerical Keys****A) Numerical Keys at System Code Level**

- i) Use 10, 20, 30, To distinguish between main systems having same Alpha Codes. Examples:
 - a) Main Steam (Left) and Main Steam (Right)
 - b) BFP – A/B/C
 - c) ID Fan – A/B, FD Fan A/B, AH – A/B
- ii) For branch off from main system path having code say 10, keep the same alpha code and use 11, 12, 13 etc. Similarly for other branch off from main system path having code say 20, keep the same alpha code and use 21, 22, 23 etc and shall carry on further in the same way.
- iii) If the branch off from main system / sub system path is used for some other system, where different alpha codes can be applied, then in that case the said branch line will be designated by the alpha codes of the system to which it is providing the input.

B) Numerical keys at Equipment Code level:

There are three numerical keys available for each type of equipment code. Following has been agreed upon considering present practice, better flexibility and ease in sorting.

- i) Valves and Dampers --- *Equipment Code – AA*

N1N2 N3

DOCUMENT TITLE			
KKS NUMBERING PHILOSOPHY			
1X800 MW KOTHAGUDEM			
Motorised (<i>on/off duty</i>)	-	0	01 to 50
Motorised (<i>inching duty</i>)	-	0	51 to 99
Pneumatic (Control)	-	1	01 to 50
Motorised (<i>thyrestor Control</i>)	-	1	51 to 99
Sol. Operated (Open / Close duty (Valves, NRVs, Gate)	-	2	01 to 99
Hydraulic	-	3	01 to 99
NRV (Without actuation)	-	4	01 to 99
Manual	-	5	01 to 99
Manual	-	6	01 to 99
Relief & Safety Valves	-	7	01 to 99
Reserve	-	8	01 to 99
Reserve	-	9	01 to 99
ii) Field Instruments			
Field Transmitters & Analog Signals	-	0	01 to 99
Field Switches & Binary Signals	-	1	00 to 99
PG Test Point	-	4	00 to 99
Gauges	-	5	00 to 99
Automatic Turbine Tester (ATT)-HWR	-	2	00 to 99
(Reserved for protection Signals used by Hardwar)			
Example of Numerical Key Usage:			
<p>In line with the philosophy adopted for Valves / Dampers /instruments etc. pumps and fans in the main systems (having different system code) can be numbered as AP/N100 and as AP/N101, 102, Where system code is same.</p>			

	TITLE: TECHNICAL SPECIFICATION FOR CHLORINATION PLANT 1X800 MW TSGENCO KOTHAGUDEM TPS STAGE -VII, PALONCHA	SPEC NO: PE-TS-410-174-A001	
		VOLUME: II-B	
		SECTION: D	
		REV NO: 00	DATE:

P&ID FOR CW/ACW SYSTEM

LEGEND

	MOTOR OPERATED GATE VALVE		DCS
	MOTOR OPERATED BUTTERFLY VALVE		ALARM
	MANUAL BUTTERFLY VALVE		ORIFICE PLATE
	NON RETURN VALVE		R.E. JOINT (STD.)
	GLOBE VALVE		VERTICAL PUMP
	AIR RELEASE VALVE		ULTRASONIC FLOW TRANSMITTER (CLAMP-ON TYPE)
	PRESSURE GAUGE		MVN - MEAN/MEDIAN VALUE SELECTION
	PRESSURE TRANSMITTER		INDICATION
	DIFFERENTIAL PRESS. GAUGE		
	DIFFERENTIAL PRESS. TRANSMITTER		
	LEVEL TRANSMITTER		
	ROTAMETER WITH 4-20ma O/P FACILITY		
	TEMPERATURE ELEMENT		
	TEMPERATURE GAUGE		
	GATE VALVE		

Pipe Sizes for carbon Steel Pipes

Pipe Size (NB)	OD (mm)	THK. (mm)
100	115	5.4
150	166.5	5.4
200	219.1	6.0
250	273	6.0
300	323.9	6.0
350	355.6	6.0
400	406.4	6.0
450	457	6.0
500	508	6.0
600	610	6.0
700	711	7.0
800	813	8.0
900	914	10.0
2000	2032	20.0
2700	2740	20.0
3800	3840	20.0

- NOTES:**
- DESIGN PRESSURE : 5.5 kg/cm² (g) FOR C.W.SYSTEM
DESIGN PRESSURE : 7.5 kg/cm² (g) FOR A.C.W. SYSTEM
DESIGN CW INLET TEMP TO CONDENSER & VACUUM PUMP EXCH. = 33 °C
DESIGN A.C.W. INLET TEMP TO PHE'S & AUX. = 33 °C
DESIGN MECHANICAL TEMPERATURE : 50 °C
 - MATERIALS OF CONSTRUCTION:**
 - PIPEING UP TO AND INCLUDING 150NB SHALL BE CARBON STEEL, ERW, IS-1239 (HEAVY GRADE)
 - PIPEING > 150NB SHALL BE CARBON STEEL (SS2002), ROLLED AND WELDED CONFORMING TO IS-3399
 - ALL PRESSURE TAPPINGS & ROOT VALVES TO BE OF 15 NB.
 - C.W. SYSTEM : 150 NB SIZE DRAIN & VENT VALVES SHALL BE PROVIDED AS REQD. AS PER LAYOUT.
 - A.C.W. SYSTEM : 50 NB SIZE DRAIN & VENT VALVES SHALL BE PROVIDED FOR PIPE SIZES 400 NB & ABOVE AS PER LAYOUT REQUIREMENT. 25 NB DRAIN & VENT VALVES SHALL BE PROVIDED FOR PIPE SIZES UP TO 350 NB AS PER LAYOUT REQUIREMENTS.
 - INSTRUMENTS MARKED - THIS SHALL BE SUPPLIED ALONGWITH THE EQUIPMENTS.
 - AIR RELEASE VALVES (150 NB) SHALL BE PROVIDED, IF REQUIRED, AS PER SURGE STUDIES.
 - PAINTING/PROTECTION - PIPES:**
 - INTERNAL SURFACE (FOR PIPE DIA 450NB AND ABOVE)
 - SURFACE CLEANING BY WIRE BRUSH, POWER TOOL CLEANING ETC.
 - APPLICATION OF ONE COAT OF EPOXY RESIN BASED RED OXIDE PRIMER FOLLOWED BY ADEQUATE NO. OF FINISH COATS OF COAL TAR EPOXY PAINT TO ACHIEVE TOTAL DRY FILM THICKNESS OF 200 MICRONS.
 - EXTERNAL SURFACE - OVERGROUND PIPING:**
 - SURFACE CLEANING BY WIRE BRUSH, POWER TOOL CLEANING ETC.
 - APPLICATION OF ONE COAT OF RED LEAD PRIMER FOLLOWED BY ADEQUATE NO. OF FINISH COATS OF SYNTHETIC ENAMEL PAINT TO ACHIEVE TOTAL DRY FILM THICKNESS OF 200 MICRONS.
 - C.W. PIPE BURIED PORTION COMING UNDER RAIL OR ROAD SHALL BE CONCRETE ENCASED / CULVERT SHALL BE PROVIDED.
 - STATUS INDICATION OF ALL MOV SHALL BE PROVIDED AS PER APPROVED DRIVE CONTROL PHILOSOPHY.
 - REFERENCE DOCUMENTS:
 - C.W. & A.C.W. SYSTEM WRITE-UP - PE-DC-410-165-N002

- NOTES:**
- EXTERNAL SURFACE - UNDERGROUND PIPING:**
 - AS PER IS 10221
 - SURFACE CLEANING BY WIRE BRUSH, POWER TOOL CLEANING ETC.
 - ALL PRIMER/COATING/WRAPPING MATERIALS AND METHOD OF APPLICATION SHALL CONFORM TO IS-10221 EXCEPT ASPHALT/BITUMEN MATERIALS (PRIMER/COATING/WRAPPING) AS PER IS-10221 ARE ALSO ACCEPTABLE.
 - PROTECTIVE COATING SHALL CONSIST OF COAL TAR PRIMER, COAL TAR ENAMEL COATING, GLASS FIBER, FIBRE INSUL WRAP FOLLOWED BY GLASS FIBER OR COAL TAR IMPREGNATED KRAFT OUTER WRAP OR FINISH COAT.
 - NUMBER OF COATS & WRAPS, MIN. THICKNESS FOR EACH LAYER OF APPLICATION SHALL BE AS PER IS-10221. NUMBER OF COATS & WRAPS SHALL BE DECIDED BASED ON SOIL RESISTIVITY AS INDICATED IN IS-10221.
 - TOTAL THICKNESS OF COMPLETED COATING & WRAPPING SHALL NOT BE LESS THAN 4.0MM.
 - ALTERNATIVELY, THE ANTI-CORROSION PROTECTION FOR BURIED PIPES CAN CONSIST OF ANTI-CORROSION PROTECTION COAT TAR TAPES. MATERIAL AND APPLICATION OF TAPES SHALL CONFORM TO IS 13337 OR EQUIVALENT. THESE TAPES SHALL BE APPLIED HOT OVER THE COOL COAL TAR PRIMER IN STEPS OF 2MM THICKNESS SO AS TO COVER THE SPIRAL EDGES OF THE FIRST TAPE BY THE APPLICATION OF SECOND TAPE. THE TOTAL THICKNESS OF THE FINISHED PROTECTIVE COATING SHALL BE 4.0MM MINIMUM.

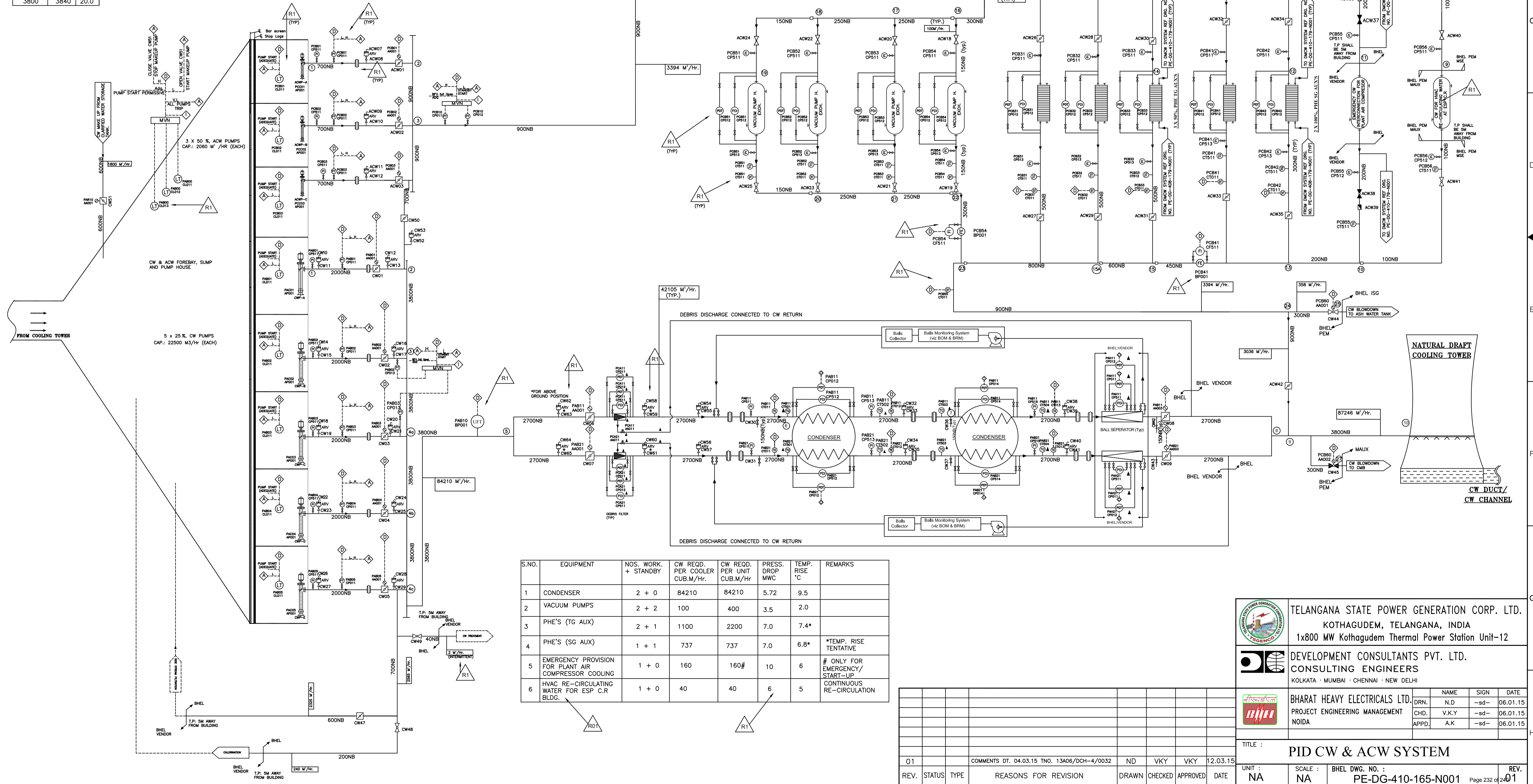

S.NO.	EQUIPMENT	NOS. WORK. + STANDBY	CW REQD. PER COOLER CUB.M/HR.	CW REQD. PER UNIT CUB.M/HR	PRESS. DROP UNIT	TEMP. RISE °C	REMARKS
1	CONDENSER	2 + 0	84210	84210	5.72	9.5	
2	VACUUM PUMPS	2 + 2	100	400	3.5	2.0	
3	PHE'S (TG AUX)	2 + 1	1100	2200	7.0	7.4*	
4	PHE'S (SG AUX)	1 + 1	737	737	7.0	6.8*	*TEMP. RISE TENTATIVE
5	EMERGENCY PROVISION FOR PLANT AIR COMPRESSOR COOLING	1 + 0	160	160#	10	6	# ONLY FOR EMERGENCY/ START-UP
6	HVAC RE-CIRCULATING WATER FOR ESP C.R BLDG.	1 + 0	40	40	6	5	CONTINUOUS RE-CIRCULATION

	TELANGANA STATE POWER GENERATION CORP. LTD. KOTHAGUDEM, TELANGANA, INDIA 1x800 MW Kothagudem Thermal Power Station Unit-12		
	DEVELOPMENT CONSULTANTS PVT. LTD. CONSULTING ENGINEERS KOLKATA · MUMBAI · CHENNAI · NEW DELHI		
	BHARAT HEAVY ELECTRICALS LTD. PROJECT ENGINEERING MANAGEMENT NOIDA		
	DRN. N.D. -sd- 06.01.15 CHD. V.K.Y -sd- 06.01.15 APPD. A.K -sd- 06.01.15	NAME SIGN DATE	

TITLE : PID CW & ACW SYSTEM			
01	COMMENTS DT. 04.03.15 TNO. 13A06/DCH-4/0032	ND	VKY
REV.	STATUS	TYPE	REASONS FOR REVISION
			DRAWN
			CHECKED
			APPROVED
			DATE
UNIT :	SCALE :	BHEL DWG. NO. :	REV. :
NA	NA	PE-DG-410-165-N001	01

	TITLE: TECHNICAL SPECIFICATION FOR CHLORINATION PLANT 1X800 MW TSGENCO KOTHAGUDEM TPS STAGE -VII, PALONCHA	SPEC NO: PE-TS-410-174-A001	
		VOLUME: II-B	
		SECTION: D	
		REV NO: 00	DATE:

PLOT PLAN

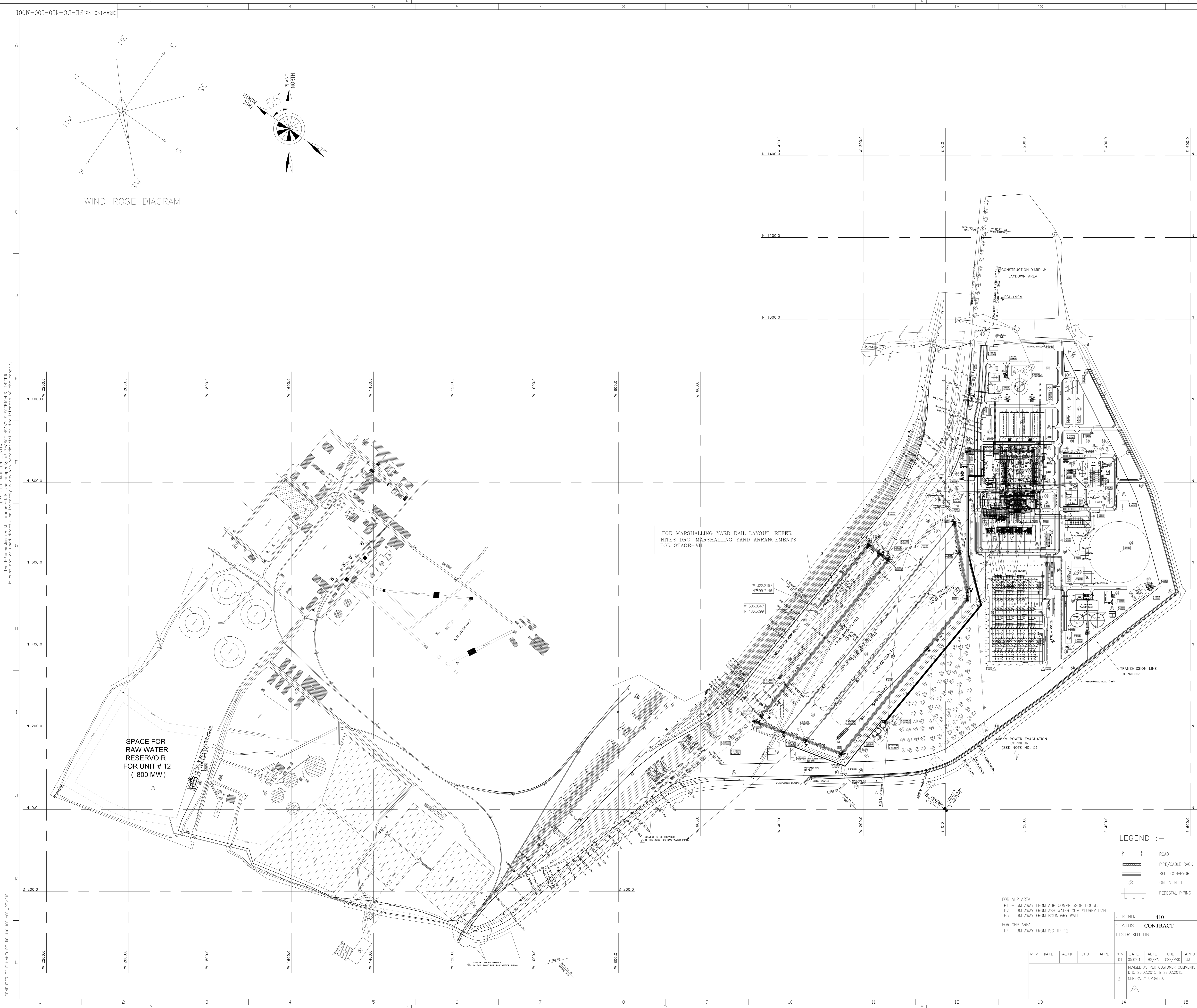

IDENTIFICATION NUMBER	DESCRIPTION
1	POWER HOUSE BUILDING INCLUDING ELECTRICAL BAY
2	COAL MILL
3	STEAM GENERATOR
4	ESP
5	CHIMNEY
6	SPACE FOR FGD PLANT
7	TRANSFORMER YARD
8	400 KV SWITCHYARD
9	COMPRESSOR HOUSE
10	MILL REJECTS LOADING HOPPERS
11	ASH WATER CUM SLURRY PUMP HOUSE
12	FLY ASH SILOS
13	BA OVER FLOW SUMP
14	BOTTOM ASH HOPPER
15	RAW WATER STORAGE RESERVOIR
16	CLARIFIERS
17	DG SET
18	SIDE STREAM FILTRATION AREA
19	OW TREATMENT & CHLORINATION AREA
20	FOAM PUMP HOUSE
21	DM PLANT
22	DM WATER STORAGE TANK
23	BOOSTER PUMP HOUSE
24	CHEMICAL HOUSE
25	NEUTRALISING PIT
26	SWITCH YARD CONTROL ROOM
27	COOLING TOWER
28	COOLING WATER PUMP HOUSE
29	TRACK HOPPER
30	WAGON TIPPLER
31	CRUSHER HOUSE
32	STACKER CUM RECLAIMER (2 Nos.)
33	CRUSHED COAL PILE
34	CHP CONTROL/ SWITCHGEAR ROOM
35	AHP COMPRESSOR HOUSE CUM AHP CONTROL SWITCHGEAR ROOM
36	THICKENER
37	SERVICE BUILDING
38	ESP CONTROL ROOMS
39	CONDENSATE STORAGE TANK AND PUMP HOUSE
40	COAL PILE SETTLING BASIN
41	SILO UTILITY BUILDING
42	TRAINING & SIMULATOR ROOM
43	PIPE/CABLE RACK (GG)
44	RAW WATER PUMP HOUSE
45	CLARIFIER ASH HANDLING SYSTEM
46	MATERIAL ENTRY GATE
47	CLARIFIED WATER STORAGE TANK & PUMP HOUSE
48	CENTRIFUGAL BUILDING
49	SLUDGE PIT
50	HFO & LDO STORAGE TANK DWYE AREA
51	HFO & LDO UNLOADING PUMP HOUSE
52	HFO & LDO FORWARDING PUMP HOUSE
53	WATCH TOWER
54	BULLDOZER SHED
55	FIRE STATION
56	FIRE WATER STORAGE TANK & PUMP HOUSE
57	WEIGH BRIDGE (GG)
58	SERVICE WATER OVER HEAD TANK (10.0M DIA.)
59	WEIGH BRIDGE FOR INDOOR STORAGE (PEM)
60	PIPE/CABLE RACK (PEM)
61	OILY WASTE TREATMENT SYSTEM
62	C.M.B. WASTE TREATMENT SYSTEM
63	BOILER WASH WATER SUMP
64	BOILER BLOW DOWN SUMP
65	T.G. WASH WATER SUMP
66	NOT USED
67	TRANSFORMER YARD WASH WATER SUMP
68	ADMINISTRATIVE BUILDING
69	CANTEN
70	INDOOR STORE
71	MAIN GATE
72	NOT USED
73	NOT USED
74	NOT USED
75	AHP SILO UTILITY MCC ROOM
76	CHP MCC
77	DS PUMP HOUSE-1
78	DS PUMP HOUSE-2
79	WT CONTROL ROOM-1&2
80	AUXILIARY BOILER
81	CHEMICAL LAB
82	CHEMICAL HOUSE (GG)
83	SECURITY OFFICE FOR MATERIAL ENTRY GATE

- NOTES:-**
- ALL DIMENSIONS AND CO-ORDINATES ARE IN METER UNLESS NOTED OTHERWISE.
 - THE FINISHED FLOOR LEVEL (FFL) OF POWER HOUSE BUILDING GROUND FLOOR IS EL. 0.00M WHICH CORRESPONDS TO 0.5M (RL 98.5M) ABOVE FGL.
 - THE EXISTING BUILDINGS SHOWN IN SHEDED LINE IN THE POWER PLANT AREA, ETC. AND AS REQUIRED FOR THE CONSTRUCTION OF THE FACILITIES FOR UNIT #12 ARE TO BE DISMANTLED.
 - THE PIPE RACK SHOWN IS INDICATIVE ONLY.
 - 400KV OUTGOING LINES ARE TO BE AUGMENTED DULY CLEARING THE RE-ROUTED 220KV LINES RUNNING ALONG THE PLANT BOUNDARY.
 - RE-ROUTING OF EXISTING 400KV LINE NEAR PROPOSED SWITCHYARD AND CHP AREA TO BE SUITABLY INCORPORATED IN THIS DRAWING BY TSSCOND.
 - CUST. GRIDS HAVE BEEN CONVERTED TO PLANT GRIDS. REFERENCE POINT HAS BEEN INDICATED.
 - DUKE TO REVISED MARSHALLING YARD, RAIL TRACKS ARE COMING OVER RAW WATER PIPES. HENCE, CULVERT TO BE PROVIDED AS INDICATED IN THE PLOT PLAN AND NECESSARY APPROVAL FROM RITES/ OTHER AGENCIES TO BE ARRANGED BY TSSCOND.

REFERENCE DWG. :-

- PLOT PLAN (CUSTOMER) 13406-DWG-M-002 REVA

LEGEND :-

- ROAD
- PIPE/CABLE RACK
- BELT CONVEYOR
- GREEN BELT
- PEDESTAL PIPING

FOR AHP AREA
 TP1 - 3M AWAY FROM AHP COMPRESSOR HOUSE
 TP2 - 3M AWAY FROM ASH WATER CUM SLURRY P/H
 TP3 - 3M AWAY FROM BOUNDARY WALL

FOR CHP AREA
 TP4 - 3M AWAY FROM ISG TP-12

CUSTOMER: TELANGANA STATE POWER GENERATION CORPORATION LTD
 TELANGANA, INDIA
 1x800 MW KOTHAGUDAM TPS STAGE-VII UNIT#12, PALONCHA

OWNER'S CONSULTANT: DEVELOPMENT CONSULTANTS PVT. LTD.
 CONSULTING ENGINEERS
 KOLKATA MUMBAI CHENNAI NEW DELHI

CLIENT: BHARAT HEAVY ELECTRICALS LTD
 POWER SECTOR
 PROJECT ENGINEERING MANAGEMENT
 NOIDA

JOB NO.	410
STATUS	CONTRACT
DISTRIBUTION	CONTRACT

REV.	DATE	ALTD	CHD	APPD	BY	DATE
01	05.02.15	BS/RA	ESF/PJK	JL		14.02.2015
1						14.02.2015
2						14.02.2015

TITLE

PLOT PLAN

SCALE 1:3000
 DRAWING NO. PE-DG-410-100-M001
 SHEET 1 OF 1 REV. 01P

COMPUTER FILE NAME: PE-DG-410-100-M001_REV.01P
 COPY RIGHT ARE CONFIDENTIAL
 THE INFORMATION ON THIS DOCUMENT IS THE PROPERTY OF BHARAT HEAVY ELECTRICALS LIMITED
 IT MUST NOT BE REPRODUCED OR TRANSMITTED IN ANY FORM OR BY ANY MEANS, ELECTRONIC OR MECHANICAL, WITHOUT THE WRITTEN PERMISSION OF THE COMPANY.

PRODUCED BY AN AUTODESK EDUCATIONAL PRODUCT



TITLE:

**TECHNICAL SPECIFICATION FOR
CHLORINATION PLANT
1X800 MW TSGENCO KOTHAGUDEM TPS
STAGE -VII, PALONCHA**

BHEL DOCUMENTS NO.: PE-TS-410-174-A001

VOLUME III

REV. NO. 00

LIST OF SCHEDULES



TITLE:

TECHNICAL SPECIFICATION FOR
CHLORINATION PLANT
1X800 MW TSGENCO KOTHAGUDEM TPS
STAGE -VII, PALONCHA

SPEC NO: PE-TS-410-174-A001

VOLUME: III

SECTION:

REV NO: 00

DATE:

SCHEDULE OF PRE-BID CLARIFICATION

All clarification from the Technical Specification shall be filled in by the BIDDER clause by clause in this format only.

VOLUME	SECTION	CLAUSE NO.	PAGE NO.	SPECIFICATION REQUIREMENT	CLARIFICATION	REASONS FOR CLARIFICATION

PARTICULARS OF BIDDER / AUTHORISED REPRESENTATIVE				COMPANY SEAL
NAME	DESIGNATION	SIGNATURE	DATE	

DEVIATION SHEET (COST OF WITHDRAWAL)**PROJECT:-1X800 MW TSGENCO KOTHAGUEM TPS ,STAGE –VII, PALONCHA****PACKAGE:- CHLORINATION PLANT****TENDER ENQUIRY REFERENCE:-****NAME OF BIDDER:-**

SL NO	VOULME/ SECTION	PAGE NO.	CLAUSE NO.	TECHNICAL SPECIFICATION/ TENDER DOCUMENT	COMPLETE DESCRIPTION OF DEVIATION	COST OF WITHDRAWAL OF DEVIATION	REFERENCE OF PRICE SCHEDULE ON WHICH COST OF WITHDRAWAL OF DEVIATION IS APPLICABLE	NATURE OF COST OF WITHDRAWAL OF DEVIATION (POSITIVE/ NEGATIVE)	REASON FOR QUOTING DEVIATION
-------	-----------------	----------	------------	--	-----------------------------------	---------------------------------	--	--	------------------------------

TECHNICAL DEVIATIONS

COMMERCIAL DEVIATIONS

PARTICULARS OF BIDDERS/ AUTHORISED REPRESENTATIVE

NAME	DESIGNATIONS	SIGN & DATE

NOTES:

- For self manufactured items of bidder, cost of withdrawal of deviation will be applicable on the basic price (i.e. excluding taxes, duties & freight) only.
- For directly dispatchable items, cost of withdrawal of deviation will be applicable on the basic price including taxes, duties & freight.
- All the bidders have to list out all their Technical & Commercial Deviations (if any) in detail in the above format.
- Any deviation not mentioned above and shown separately or found hidden in offer, will not be taken cognizance of.
- Bidder shall submit duly filled unpriced copy of above format indicating "quoted" in "cost of withdrawal of deviation" column of the schedule above along with their Techno-commercial offer, wherever applicable.
- Bidder shall furnish price copy of above format along with price bid.
- The final decision of acceptance/ rejection of the deviations quoted by the bidder shall be at discretion of the Purchaser.
- Bidders to note that any deviation (technical/commercial) not listed in above and asked after Part-I opening shall not be considered.
- For deviations w.r.t. Payment terms, Liquidated damages, Firm prices and submission of E1/ E2 forms before claiming 10% payment, if a bidder chooses not to give any cost of withdrawal of deviation loading as per Annexure-VIII of GCC, Rev-06 will apply. For any other deviation mentioned in un-priced copy of this format submitted with Part-I bid but not mentioned in priced copy of this format submitted with Priced bid, the cost of withdrawal of deviation shall be taken as NIL.
- Any deviation mentioned in priced copy of this format, but not mentioned in the un-priced copy, shall not be accepted.
- All techno-commercial terms and conditions of NIT shall be deemed to have been accepted by the bidder, other than those listed in unpriced copy of this format.
- Cost of withdrawal is to be given separately for each deviation. In no event bidder should club cost of withdrawal of more than one deviation else cost of withdrawal of such deviations which have been clubbed together shall be considered as NIL.
- In case nature of cost of withdrawal (positive/negative) is not specified it shall be assumed as positive.
- In case of discrepancy in the nature of impact (positive/ negative), positive will be considered for evaluation and negative for ordering.



TITLE:

**TECHNICAL SPECIFICATION FOR
CHLORINATION PLANT
1X800 MW TSGENCO KOTHAGUDEM TPS
STAGE –VII, PALONCHA**

SPEC NO: PE-TS-410-174-A001

VOLUME: III

SECTION:

REV NO: 00

DATE:

COMPLIANCE CUM CONFIRMATION SCHEDULE

The bidder shall confirm compliance with following by signing/ stamping this compliance certificate and furnishing same with the offer:

- a.) The scope of supply, technical details, construction features, design parameters etc. shall be as per technical specification & there are no exclusions/ deviations with regard to same.
- b.) QP/ test procedures shall be submitted in the event of order based on the guidelines given in the specification & QP enclosed therein.
QP will be subject to BHEL/Customer approval in the event of order & customer hold points for inspection/ testing shall be marked in the QP at the contract stage. Inspection/ testing shall be witnessed as per same apart from review of various test certificates/ Inspection records etc.
The charges for 3rd party inspection (Lloyds, TUV or equivalent) for imported components shall be included in the base price of the equipment by the bidder
- c.) All drawings/data – sheets etc. to be submitted during contract shall be subject to BHEL/Customer review/ approval. GA drawings, as submitted with offer at tender stage are for reference purpose only and shall be subject to approval during contract stage.
- d.) There are no other deviations with respect to specification other than those furnished in the 'Schedule of Deviations'
- e.) The offered materials shall be either equivalent or superior to those specified. Also for components where material is not specified it shall be suitable for intended duty, materials shall be subject to approval in the event of order.
- f.) The commissioning spares (if any) are supplied on 'As Required Basis' & prices for same included in the base price (If bidders reply to this is "No commissioning spares are required" and if some spares are actually required during commissioning same shall be supplied by bidder without any cost to BHEL).
- g.) All sub vendors shall be subject to BHEL/CUSTOMER approval
- h.) Any special tools & tackles, if required, shall be in bidder's scope.
- i.) Demonstration parameters shall stand valid till the satisfactory completion of demonstration test and its acceptance by BHEL/Customer.



TITLE: TECHNICAL SPECIFICATION FOR
CW TREATMENT PLANT
1X800 MW TSGENCO KOTHAGUDEM TPS
STAGE –VII, PALONCHA

BHEL DOCUMENTS NO.: PE-TS-410-174-A001

VOLUME III

REV. NO. 00

SUGGESTIVE PRICE FORMAT FOR CHLORINATION PLANT FOR 1X800 MW KOTHAGUDEM TPS.

Sl. No.	DESCRIPTION OF EQUIPMENT / ITEM	TOTAL PRICE FOR "FOR" SITE
(1)	(2)	(3)
1.0	Total lump-sum firm price on "FOR" site basis for design, engineering, manufacturing, painting, inspection & testing at manufacturer's works, supply, complete with all accessories including start up and commissioning spares as required, mandatory spares as specified in specification, packing, shipment and delivery to Power Station Site. In addition, the bidder's scope shall include erection and commissioning, unloading, storage and handling at site, site testing, trial run, performance and guarantee tests and handing over to customer the COOLING WATER (CW), RW WATER (RW) & POTABLE WATER (PW) CHLORINATION PLANT & ABSORPTION SYSTEM for 1X800 MW TSGENCO KOTHAGUDEM TPS STAGE –VII, PALONCHA as per Technical Specification PE-TS-410-174-A001 and as required for safe and trouble free smooth operation.	
	NOTES:	
a	Bidder to note that total price indicated above at 1.0 shall be considered for evaluation and hence should be complete in all respect for the full scope defined and considering all terms and conditions agreed.	
b	In case, price indicated above does not match with item wise break-up given at 2.0, the highest price so calculated shall be considered for evaluation but in case of order, the same shall be placed at the lowest price.	
2.0	BREAK-UP OF PRICES GIVEN IN 1.0 ABOVE	
2.1	Total lump sum firm price for EQUIPMENT (SUPPLY) i.e. manufacture, inspection, testing at vendor / sub vendor works, packing, forwarding, including start up and commissioning spares as required, etc. but exclusive of all taxes & duties for the complete scope of supply of CW CHLORINATION PLANT AND ABSORPTION SYSTEM as defined in the BHEL tender specification (PE-TS-410-174-A001) for delivery up to site basis (freight included).	
2.2	Total lump sum firm price for EQUIPMENT (SUPPLY) i.e. manufacture, inspection, testing at vendor / sub vendor works, packing, forwarding, including start up and commissioning spares as required etc. but exclusive of all taxes & duties for the complete scope of supply of RW CHLORINATION PLANT AND ABSORPTION SYSTEM as defined in the BHEL tender specification (PE-TS-410-174-A001) for delivery up to site basis (freight included).	
2.3	Total lump sum firm price for EQUIPMENT (SUPPLY) i.e. manufacture, inspection, testing at vendor / sub vendor works, packing, forwarding, including start up and commissioning spares as required, etc. but exclusive of all taxes & duties for the complete scope of supply of PW CHLORINATION PLANT as defined in the BHEL tender specification (PE-TS-410-174-A001) for delivery up to site basis (freight included).	
	Total lump sum firm price for supply of mandatory spares for COOLING WATER (CW), RW WATER (RW) & POTABLE WATER (PW) CHLORINATION PLANT & ABSORPTION SYSTEM as specified in Technical specification (PE-TS-410-174-A001)	
2.4	Total lump sum firm price for Erection & Commissioning as indicated in technical specification and handing over to Purchaser the entire CW Chlorination plant with absorption system specified in Technical specification (PE-TS-410-174-A001) as required for safe and trouble free smooth operation.	
2.5	Total lump sum firm price for Erection & Commissioning as indicated in technical specification and handing over to Purchaser the entire RW Chlorination plant with absorption system specified in Technical specification (PE-TS-410-174-A001) as required for safe and trouble free smooth operation.	
2.6	Total lump sum firm price for Erection & Commissioning as indicated in technical specification and handing over to Purchaser the entire PW Chlorination plant specified in Technical specification (PE-TS-410-174-A001) as required for safe and trouble free smooth operation.	
2.7	Total lump sum firm price for PG test and handing over of COOLING WATER (CW), RW WATER (RW) & POTABLE WATER (PW) CHLORINATION PLANT & ABSORPTION SYSTEM	
2.8	Taxes & duties etc.	



TITLE
*** SCHEDULE OF DECLARATIONS**

BHEL DOCUMENTS NO.: PE-TS-410-174-A001

VOL III

SHEET..... OF.....

*** Bidder shall include this schedule both in technical and Price offers**

DECLARATION

Icertify that all the technical data and information pertaining to this specification are correct and are true representation of the equipment/system covered by our format proposal number Dated and there is no deviation to the specification (except indicated in the deviation sheet (cost of withdrawal).

I hereby certify that I am duly authorized representative of the Bidder's company whose name appears above my signature.

Biders Company Name

Authorised representative's Signature

Name

Bider's Name The bidder hereby agrees to fully comply with the requirements and intent of this specification for the price indicated

PARTICULARS OF BIDDER / AUTHORISED REPRESENTATIVE				
NAME	DESIGNATION	SIGNATURE	DATE	COMPANY SEAL