

2X500 MW NNTPS NEW NEYVELI

TECHNICAL SPECIFICATION FOR CONDENSER ON LOAD TUBE CLEANING SYSTEMS (COLTCS).

Specification No. : PE-TS- 402-165-N002 (REV. 0)

VOLUME -IIB

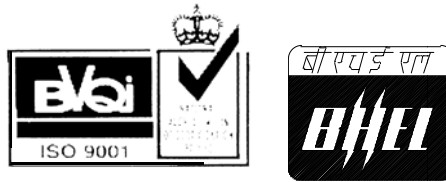

**BHARAT HEAVY ELECTRICALS LIMITED
POWER SECTOR
PROJECT ENGINEERING MANAGEMENT
PPEI BLDG., SEC-16A, PLOT NO. 25
NOIDA – 201301 (UP)**

	TITLE : TECHNICAL SPECIFICATION FOR CONDENSER ON LOAD TUBE CLEANING SYSTEMS (COLTCS). PREAMBLE	SPEC. NO. PE-TS- 402-165-N002	
		VOLUME : II B	
		REV. NO. 0	DATE :19.05.14
		SHEET 1 OF 2	

1.0 The tender document contains three (3) volumes. The bidder shall meet the requirements of all the three volumes.

1.1 **Volume -I CONDITIONS OF CONTRACT**

This consists of four parts as below :

Volume - I A : This part contains instructions to bidders for making bids to BHEL.

Volume - I B : This part contains general commercial conditions of the tender and include provision that vendor shall be responsible for the quality of item supplied by their sub-vendors.

Volume - I C : This part contains special conditions of contract.

Volume - I D : This part contains commercial conditions for erection and commissioning site work, as applicable.

1.2 **Volume - II TECHNICAL SPECIFICATIONS**

Technical requirements are stipulated in Volume II which comprises of :

Volume - II A : General Technical Conditions

Volume - II B : Technical specification including drawings, if any

1.2.1 **Volume - II B :**

This volume is sub-divided into following sections:

Section - A : This section outlines the scope of enquiry.

Section - B : This section provides "Project Information"

Section - C : This section indicates technical requirements specific to the contract, not covered in Section-D.

Section - D : This section comprises of standard technical specifications of equipments complete with data sheet A, B & C.

Data sheet-A specifies data and other requirements pertaining to the equipment.

Data sheet - B specifies data to be filled by the bidder (Data Sheet B is contained in Volume - III)

Data sheet - C indicates data documents to be furnished after the award of contract as per agreed schedule by the vendor (as applicable).



TITLE : TECHNICAL SPECIFICATION
FOR
CONDENSER ON LOAD TUBE CLEANING
SYSTEMS (COLTCS).
PREAMBLE

SPEC. NO. PE-TS- 402-165-N002

VOLUME : II B

REV. NO. 0 | DATE :19.05.14

SHEET 2 OF 2

1.2.2 **Volume - III TECHNICAL SCHEDULES**

- 1.0 This volume contains technical schedules and Data Sheets - B, which are to be duly filled by the bidder and the same shall be furnished with the technical bid as per instructions given in Document No.PES-100-901 in Volume-III.
- 2.0 The requirements mentioned in Section C/Data Sheets-A of Section-D shall prevail and govern in case of conflict between the same and the corresponding requirements mentioned in the descriptive portion in Section -D.



**TITLE : TECHNICAL SPECIFICATION
FOR
CONDENSER ON LOAD TUBE CLEANING
SYSTEMS (COLTCS).**

SPEC. NO. PE-TS-402-165-N002

VOLUME : II B

SECTION : A

REV. NO. 0

DATE : 19.05.2014

SHEET 1 of 1

INDEX

SECTION	TITLE
A	SCOPE OF ENQUIRY
B	PROJECT INFORMATION
C	SPECIFIC REQUIREMENTS
C1	SPECIFIC TECHNICAL REQUIREMENTS FOR CONDENSER ONLOAD TUBE CLEANING SYSTEMS .
C2	SPECIFIC TECHNICAL REQUIREMENTS (ELECTRICAL)
C3	SPECIFIC TECHNICAL REQUIREMENTS (C&I)
D	STANDARD TECH. SPECIFICATIONS
D1	CONDENSER ON LOAD TUBE CLEANING SYSTEMS <ul style="list-style-type: none">◆ STANDARD TECHNICAL SPEC.NO. PE-TS-999-165-N001◆ DATA SHEET-A◆ DATA SHEET-C◆ QUALITY PLAN
D2	ELECTRICAL SYSTEMS
D3	CONTROL & INSTRUMENTATION SYSTEMS



**TITLE : TECHNICAL SPECIFICATION
FOR
CONDENSER ON LOAD TUBE CLEANING
SYSTEMS (COLTCS).**

SPEC. NO. PE-TS-402-165-N002

VOLUME : II B

SECTION : A

REV. NO. 0

DATE : 19.05.2014

SHEET

1

of

1

**SECTION - A
SCOPE OF ENQUIRY**



TITLE : TECHNICAL SPECIFICATION
FOR
CONDENSER ON LOAD TUBE CLEANING
SYSTEMS (COLTCS).

SPEC. NO. PE-TS-402-165-N002

VOLUME : II B

SECTION : A

REV. NO. 0

DATE : 19.05.14

SHEET 1

of

1

1.00.0 SCOPE

This enquiry covers the design, manufacture, assembly, inspection and testing at manufacturer's and/or his sub-contractors works properly packed for delivery of the items as follows:

1.01.0 Condenser On Load Tube Cleaning Systems :

Condenser On Load Tube Cleaning Systems (COLTCS) complete with all accessories as per the requirements specified in different sections of this specification for:

- **2X500 MW NNTPS NEW NEYVELI.**

The bidder's scope also includes installation checks, commissioning, trial runs & PG Testing at site of COLTCS.

1.01.0 The bids shall be evaluated as per NIT.

2.00.00 GENERAL TECHNICAL INSTRUCTIONS:

2.01.00 It is not the intent to specify herein all the details of design and manufacture. However the equipment shall conform in all respects to high standard of design, engineering and workmanship, and shall be capable of performing the required duties in a manner acceptable to Engineer/ Owner, who will interpret the meaning of drawing and specifications, and shall be entitled to reject any component or material, which in his judgement is not in full accordance herewith.

2.0.2.00 The omission of specific reference to any component/ accessory necessary for the proper performance of the equipment's shall not relieve the bidder of the responsibility of providing such facilities to complete the supply of the equipment's at quoted prices.

2.03.00 In case of any deviation from this Technical specification (Vol. IIB) and General Technical Conditions (Vol. IIC), the same shall be indicated in the schedule of deviations enclosed in Volume-III, Part-A. In the absence of duly filled schedules it will be assumed that the bid strictly conforms to the specification.

2.04.00 BHEL's/ Customer's representatives shall be given full access to the shop in which the equipment's are being manufactured or tested and all test records shall be made available to him.

2.05.00 The equipment's covered under this specification shall not be despatched unless the same have been finally inspected, accepted and shipping release issued by BHEL/ Customer

2.06.00 Un-priced copy of price bid shall be furnished along with the technical bid.



**TITLE : TECHNICAL SPECIFICATION
FOR
CONDENSER ON LOAD TUBE CLEANING
SYSTEMS (COLTCS)**

SPEC. NO. PE-TS- 392-165-N002

VOLUME : II B

SECTION : C

REV. NO. 0

DATE : 19.05.2014

SHEET 1 of 1

SECTION - B

PROJECT INFORMATION



SECTION - 2

2 GENERAL PROJECT INFORMATION

2.1 Introduction

The project site at Neyveli has distinct location advantages, being at pit-head distance from the source of lignite supply from Mines, making it convenient for transportation of lignite by belt conveyor. Water source is readily available from the nearby mines lake. Besides, other infrastructure such as access road, railway connection etc, already exist.

2.2 Power Plant Site

The power plant site is located at Neyveli, opposite to the now defunct Fertilizer and Briquetting & Carbonization Plant, near TPS-1 Expansion and TPS-II.

2.3 Project & Site Information

- | | | | |
|---------|---------------------------------|---|--|
| (i). | Owner/Purchaser | : | Neyveli Lignite Corporation Limited (NLC Ltd), Neyveli, Cuddalore District, Tamil Nadu State, India |
| (ii). | Consultant | : | Lahmeyer International (India) Pvt. Ltd (LII), Gurgaon, NCR, India. |
| (iii). | Project Title | : | 2x500 MW Neyveli New Thermal Power Station (NNTPS) |
| (iv). | Location | : | 200 kms south of Chennai and 50 kms south-west of Cuddalore |
| (v). | Latitude | : | 11° 34' 00" N to 11° 35' 00" N |
| (vi). | Longitude | : | 79° 26' 00" E to 79° 27' 00" E |
| (vii). | Elevation above MSL | : | + 67 m |
| (viii). | Nearest Railway Station | : | Neyveli, |
| (ix). | Nearest Sea Port | : | Chennai, at a distance of 200 km |
| (x). | Nearest Airport | : | Chennai, at a distance of 200 km |
| (xi). | Road Access/Approach to Site | : | Connected by Chennai-Thanjavur NH 45C road and state highway connecting Cuddalore – Virudhachalam via Neyveli. Both NH and state high way roads are well connected to NLC township roads. The approach road is approximately 15 kms from Chennai–Thanjavur NH – 45C road |
| (xii). | Site Meteorological Data | | |
| | • Max ambient temperature | : | 42.8° C |

Document Number	Rev No.	Description	Page No.	Date of Issue
LII-GEOE11019-G-00156-002	02	TG, Vol-IA, IFB-NTA2	- 9-	25-Jun-11



- Min Ambient Temperature : 26.9° C
 - Wet bulb temp : 29° C
 - Max. Relative Humidity : 92 % in the month of September
 - Min. Relative Humidity : 23 % in the month of May
 - Rainfall : About 1265.7 mm annually (average)
 - Wind direction : South West to North East direction
 - Wind Speed : 97.2 km/hr (maximum recorded)
4.3 km/hr (average wind speed)
 - Seismicity : As per IS: 1893 (part 4) (Zone-II)
Importance factor: 1.75.
- (xiii). Languages spoken in the region : English, Tamil

* * * * *

Document Number	Rev No.	Description	Page No.	Date of Issue
LII-GEOE11019-G-00156-002	02	TG, Vol-IA, IFB-NTA2	- 10-	25-Jun-11



**ATTACHMENT - 1
RAW WATER ANALYSIS**

The typical raw water analysis is as shown below:

S.No	Description	Unit	Normal Values
1	Source		Lake water
2	Temperature	°C	30
3	Colour	-	Colourless
4	Odour	-	Odourless
5	Oil	mg/l	Nil
6	Grease	mg/l	Nil
7	Total solids in ppm	mg/l	519
8	Calcium hardness as CaCO ₃	mg/l	120
9	Magnesium hardness as CaCO ₃	mg/l	78
10	Sodium + Potassium as CaCO ₃	mg/l	95.35
11	Chloride as CaCO ₃	mg/l	84.6
12	Sulphate as CaCO ₃	mg/l	84.7
13	M alkalinity as CaCO ₃	mg/l	160
14	P alkalinity as CaCO ₃	mg/l	Nil
15	Iron as CaCO ₃	mg/l	1.25
16	Silica as SiO ₂	mg/l	36.4
17	Aluminium as CaCO ₃	mg/l	34.7
18	Conductivity at 30 °C	m-	590
19	pH at 30 °C	-	7.0
20	Free CO ₂	-	19.36
21	Total hardness (as CaCO ₃)	mg/l	198

Document Number	Rev No.	Description	Page No.	Date of Issue
LII-GEOE11019-G-10055-002	02	NTA2- Vol – IIA, Attach – 1	1	25-Jun-11



**TITLE : TECHNICAL SPECIFICATION
FOR
CONDENSER ON LOAD TUBE CLEANING
SYSTEMS (COLTCS)**

SPEC. NO. PE-TS- 392-165-N002

VOLUME : II B

SECTION : C

REV. NO. 0

DATE : 19.05.2014

SHEET 1 of 1

SECTION – C

SPECIFIC REQUIREMENTS

- SECTION C1 : CONDENSER ONLOAD TUBE CLEANING SYSTEMS**
- SECTION C2 : ELECTRICAL SYSTEMS**
- SECTION C3 : C&I SYSTEMS**



**TITLE : TECHNICAL SPECIFICATION
FOR
CONDENSER ON LOAD TUBE CLEANING
SYSTEMS (COLTCS)**

SPEC. NO. PE-TS- 402-165-N002

VOLUME : IIB

SECTION : D

REV. NO. 0

**DATE :
19.05.2014**

SHEET 1 of 1

**SECTION C1
CONDENSER ONLOAD TUBE CLEANING SYSTEMS
(MECHANICAL DETAILS)**



**TITLE : TECHNICAL SPECIFICATION
FOR
CONDENSER ON LOAD TUBE CLEANING
SYSTEMS (COLTCS)**

SPEC. NO: PE-TS-402-165-N002

VOLUME : II B

SECTION:C1

REV. NO. 0

DATE : 19.05.14

SHEET 1 OF 10

1.0 GENERAL

The Condenser On load Tube Cleaning Systems (COLTCS) complete with all accessories shall conform to the standard technical specifications (Section-D) and Data Sheet-A enclosed herewith. In addition the requirements of this section C shall also be complied with. However, wherever the details given in Section-D and Data Sheet-A are different, the requirements of Data Sheet-A shall prevail. Similarly in the event of contradictions between Section-C & Section-D/ Data Sheet-A, Section-C shall prevail.

Section C consists of 3 parts viz. Sec. C1, C2 and C3 for Mechanical, Electrical and C&I respectively, the requirements of all 3 sections shall be complied with.

2.0 DESCRIPTION OF EQUIPMENTS :

2.1 Condenser on load tube cleaning systems (COLTCS) :

The condenser on load tube cleaning system (COLTCS) is intended to prevent formation of various forms of fouling and scaling in the condenser tubes. The cooling water system is of closed circuit type with cooling towers or open circuit type as specified. The water analysis is indicated in project information in section B.

3.0 SCOPE OF SUPPLY UNDER THE SPECIFICATION IN THE BIDDER'S SCOPE FOR COLTCS.

3.1 The scope of supply for COLTCS covered under this specification is as under.

The size, MOC's and other particulars of the equipments for various projects are detailed in Data Sheet A annexed with Section – D of the specification.

SL.NO.	PROJECT	COLTCS
1.	2X500 MW NNTPS NEW NEYVELI	2 SETS PER UNIT viz. TOTAL 4 SETS FOR BOTH UNIT.



TITLE : TECHNICAL SPECIFICATION
FOR
CONDENSER ON LOAD TUBE CLEANING
SYSTEMS (COLTCS)

SPEC. NO: PE-TS-402-165-N002

VOLUME : II B

SECTION:C1

REV. NO. 0

DATE : 19.05.14

SHEET 2 OF 10

3.2 SCOPE OF SUPPLY IN THE BIDDER'S SCOPE FOR COLTCS:

3.2.1 Each set of COLTCS for each projects shall comprise of following :

- a) One No. Ball Separator at Condenser CW outlet pipe.
- b) One No. Ball recirculation pump with drive motor.
- c) One No. Ball collector.
- d) One No. Manual ball sorter (Bucket type sorter with sieves to manually sort out the undersized balls by shaking the sieved bucket manually) for each set of COLTCS.
- e) Differential pressure measuring system for ball separator. DP measuring system shall comprise of 2 nos. DPT +1 no. DPG for each COLTCS. Instrument shall be with *Remote seal* arrangement. Stubs for DPT and DPG shall be independent.
- f) Ball monitoring system comprising of an independent balls recirculation monitor and an independent balls oversize monitor. If bidder is not manufacturing Ball over size monitor then they can offer other alternatives like automatic ball sorter etc.
- g) Length of Ball separator, Scope of Counter Flange, Nuts and bolts shall be as per Annexure- I of section C1.
Thickness of body flange and counter flange shall be as per Drg no PE-DG-999-141-MO17 enclosed at enclosures at Annexure-II.
- h) Complete Pipe work, including interconnection piping, flanges/counter flanges for valves & pipes, bends, fittings, distributors, nozzles and support installation materials shall be in Bidder's scope. Bidder shall finalize the pipework to suit the layout at contract stage in such a way that no site welding is required for his pipework otherwise the same shall be carried out by bidder at site.
- i) The Electrical and C&I item / accessory as specified in succeeding clause/ respective sections herein.
- j) Power and Control cables between Local Control Panel, PLC and various drives in bidder's scope of supply.
- k) Local Control Panel shall be as follows:
 - a) 2 Sets of COLTCS shall have one Common PLC Control System. However, separate LCP shall be provided for each set of COLTCS.

Local Control Panel should have suitable arrangement like Bus Coupler for providing redundancy to incoming supply feeder (1 Working + 1 Standby feeder).



TITLE : TECHNICAL SPECIFICATION
FOR
CONDENSER ON LOAD TUBE CLEANING
SYSTEMS (COLTCS)

SPEC. NO: PE-TS-402-165-N002

VOLUME : II B

SECTION:C1

REV. NO. 0

DATE : 19.05.14

SHEET 3 OF 10

- l) Control cables between field instruments and Local Control panel.
- m) Control Cables along with connecting accessories from PLC to DCS as mentioned in Section C3.
- n) Laptop as per C&I Requirement mentioned in Section C3.
- o) All the field instruments stipulated in this specification shall be in Bidder's scope.
- p) Commissioning balls and other commissioning spares on "As required basis".
- q) Set of mandatory spares as indicated in Data Sheet A.
- r) Supporting arrangement complete with saddle support (as required as per layout), foundation plates, anchor bolts, nuts, sleeves, inserts, all installation materials, fixing bolts, clamps and other accessories etc. for complete equipment supplied under this package.
- s) Finish paints for touch up painting of equipment after erection at site, in sealed containers.
- t) Set of special tools and tackles (if required) for maintenance and erection of the equipment supplied.
- u) Various drawings, data test reports/ certificates instruction manuals for erection operation and maintenance etc. as specified in Data Sheet-C. and cables schedule indicating BOQ for power & control cables.
- v) Panels & Instruments: Scope and Type as specified in C&I section wherever required.

Any item not specified but required to make COLTCS a complete package shall also be in bidder's scope.

4.0 SCOPE OF SERVICES INCLUDED IN THE BIDDER'S SCOPE :

The bidder's scope also includes following services at site, for scope under this specification for COLTCS for respective projects

- a) Installation checks (Erection in BHEL's scope).
- b) Commissioning of equipment.
- c) Trial run for requisite period
- d) Performance Testing.



TITLE : TECHNICAL SPECIFICATION
FOR
CONDENSER ON LOAD TUBE CLEANING
SYSTEMS (COLTCS)

SPEC. NO: PE-TS-402-165-N002

VOLUME : II B

SECTION:C1

REV. NO. 0

DATE : 19.05.14

SHEET 4 OF 10

The trial run of equipment shall be generally conducted immediately after commissioning while PG testing shall be conducted at a later date. These activities for different units shall be timed separately.

The no. of visits may be suitably assessed by bidders as per their experience with site stay periods on as required basis.

In the event of order number of visits as follows shall be made as a minimum with charges included in the bidder's base price itself.

- **For drawings/documents approval**

In the event of order all drawings / documents in soft as well as hard copy shall be submitted as per NIT.

Further on receipt of Customer comments, if required bidder's engineer shall visit BHEL/ Customer alongwith soft copy to resolve all issues and incorporate comments in the soft copy for across the table finalisation and Category-I approval.

- **Site Visits :**

- i. No. of site visits for combined activities of erection checks and commissioning for COLTCS as applicable shall be one per unit - for both sets of equipments of one unit. Time duration for erection and commissioning shall be "on as required basis" with equipments run for trial operation thereafter for requisite period to demonstrate satisfactory operation.

However the no. of visits may be suitably assessed by bidders as per their experience with site stay periods on as required basis.

- ii. Bidder shall demonstrate guarantees including balls recovery, life of balls, pressure drops, etc. at site during subsequent visit for COLTCS of each unit.
- iii. For trouble shooting on "as required basis".



TITLE : TECHNICAL SPECIFICATION
FOR
CONDENSER ON LOAD TUBE CLEANING
SYSTEMS (COLTCS)

SPEC. NO: PE-TS-402-165-N002

VOLUME : II B

SECTION:C1

REV. NO. 0

DATE : 19.05.14

SHEET 5 OF 10

5.0 EXCLUSIONS :

The following are excluded from the bidder's scope .

- 5.1 Civil foundation works required for installation
- 5.2 Erection of Equipment at site.

6.0 DESIGN CONSTRUCTION :

In addition to the requirements of Section-D the following shall also be complied with for packages/ projects under scope of this specification:

- 6.1 For COLTCS - Layout Piping Arrangement Drg. is enclosed in the specifications at Annexure-III.
- 6.2 Thickness of body flange and counter flange of COLTCS shall be as per Drg no PE-DG-999-141-MO17 enclosed at enclosures at Annexure-II.
- 6.3 The materials of construction specified in Data Sheet-A are minimum requirements and materials of construction for other components not specified shall be similarly selected by the bidder for the intended duty which shall be subject to purchaser's approval during detailed engineering in the event of order.
- 6.4 Housing/ body of COLTCS shall be designed and manufactured as per the applicable codes for pressure vessels and to take care of force and moments as enclosed in the specification. However in no case thickness of housing/ body shall be less than connecting pipe thickness as specified in Data Sheet-A of COLTCS.
- 6.5 Adequate provision for future installation of Cathodic Protection for COLTCS (Sacrificial type) shall be kept by the bidder in the equipment.
- 6.6 Any flow straightner for streamlining the CW flow in balls collecting strainer if required shall be supplied by the bidder along with mounting arrangement and the fixing details.
- 6.7 Velocity in the pipe work shall be less than 1.5 m/ sec for pump suction and less than 2.5 m/ sec. in other pipe work. All valves upto 150 NB shall be ball valves. For higher sizes, gate/ globe/ B.F. valves shall be provided. All instrument valves shall be needle valves.



TITLE : TECHNICAL SPECIFICATION
FOR
CONDENSER ON LOAD TUBE CLEANING
SYSTEMS (COLTCS)

SPEC. NO: PE-TS-402-165-N002

VOLUME : II B

SECTION:C1

REV. NO. 0

DATE : 19.05.14

SHEET 6 OF 10

7.0 Performance Guarantee and Testing :

The Tube Cleaning Systems shall be guaranteed to meet the performance requirements specified in Section-D and also for trouble free operation after commissioning. Schedule of performance guarantees (enclosed in Volume III) duly filled and signed shall be furnished with the bid.

The Performance guarantees of equipments shall stand valid till the satisfactory completion of performance testing & its acceptance by BHEL/ Consultant/Customer. If the guarantee period specified in the Commercial Specification is higher, same shall prevail.

8.0 Performance Guarantee and Bid Evaluation criteria for Condenser on Load Tube Cleaning System.

8.1 Condenser On Load Tube Cleaning Systems.

8.1.1a Performance Parameters to be guaranteed by bidders for COLTCS-under penalty (Liquidated damages) shall be as under :

- i) Pressure drop in ball separator in clean condition (test to be conducted along with commissioning of COLTCS).

The cl. No. 8.1.2 in subsequent paragraphs shall be referred regarding liquidated damages.

8.1.1b Performance Parameters to be guaranteed by bidders for COLTCS-under demonstration category under compulsory corrections shall be as under:

- ii) Percentage recovery of balls (min. 90% recovery for 3 weeks with 8 hrs operation of COLTCS per day)
- iii) Life of Sponge Rubber Ball (Min. 3 weeks with 8 hrs operation of COLTCS per day).

For demonstrating the parameters at sl. No. (ii) & (iii) above, the COLTCS system shall be operated 24 hrs per day for one week.

Any deviation to above balls life and percentage recovery will not be accepted.

In case the successful bidder fails to demonstrate any of these parameters he shall carry out modifications at his own cost, to purchaser's approval.

In case bidder fails to demonstrate above parameters to purchaser's satisfaction even after modification carried by him at site, the purchaser has the right to reject the equipment out rightly.



TITLE : TECHNICAL SPECIFICATION
FOR
CONDENSER ON LOAD TUBE CLEANING
SYSTEMS (COLTCS)

SPEC. NO: PE-TS-402-165-N002

VOLUME : II B

SECTION:C1

REV. NO. 0

DATE : 19.05.14

SHEET 7 OF 10

8.1.1 Bidder to note that bids shall be evaluated on account of pressure drop across ball collecting strainer (in clean condition) and liquidated damages on account of not meeting the same during PG test shall be in accordance with following:

A) Bid Evaluation Criteria & Liquidated Damages:

The bids received shall be evaluated for Pressure drop across balls collecting strainers:

- The permissible limit of pressure drop across balls collecting strainers in clean condition shall be 0.15 MWC.
- If the pressure drops quoted are higher than above limit, the bids shall be technically loaded @ Rate as mentioned in Data Sheet-A on pro-rata basis for respective projects per **0.05 MWC** pressure drop across each balls collecting strainer.
- However no advantage shall be given for pressure drops quoted less than above permissible limit.
- The maximum acceptable limit for pressure drop across balls collecting strainer shall be (with technical loadings) 0.2 MWC.
The bids will be technically rejected for pressure drops quoted higher than above maximum limit.
- The guaranteed pressure drops shall be demonstrated at site by bidder and if found higher shall be subject to LD @ twice the bid evaluation factor as above.

9.0 SPARES :

9.1 Recommended Spares :

Bidder to submit the list of recommended spares (along with prices) as per NIT required for three (3) years of reliable operation and maintenance of COLTCS for BHEL reference purpose only.

The recommended spares shall not be considered for evaluation and ordering purpose.

9.2 Mandatory Spares

Mandatory Spares shall be as per Data Sheet-A or annexure enclosed with data sheet A.

10.0 Quality Plan

Bidder shall submit QP in the event of order based on the guidelines given in the specification & QP enclosed therein. QP will be subject to BHEL/ Customer approval and customer hold points for inspection/ testing shall be marked in the QP at the contract stage. Inspection/ testing shall be witnessed as per same apart from review of various test certificates/ Inspection records etc. Charges for 3rd party inspection (TUV/ equivalent) for imported components wherever required shall be included by bidder in the base price itself. Witness for all the test identified under agency "C" & "N" in Quality plan shall be by third party.



TITLE : TECHNICAL SPECIFICATION
FOR
CONDENSER ON LOAD TUBE CLEANING
SYSTEMS (COLTCS)

SPEC. NO: PE-TS-402-165-N002

VOLUME : II B

SECTION:C1

REV. NO. 0

DATE : 19.05.14

SHEET 8 OF 10

If BHEL or BHEL customer decides to witness the tests along with third party, the cost of travel of BHEL or BHEL customer shall be borne by BHEL or BHEL customer themselves.

10.0 DELIVERY & DRAWINGS/ DOCUMENTS DISTRIBUTION SCHEDULE :

- a. Delivery of Equipment for each project shall be as per NIT.
- b. Drawings submission schedule shall be as per NIT/as advised by Project Group.

11.0 The makes of various bought out items shall be subjected to purchaser's approval in the event of order.

12.0 It is mandatory for the bidders to submit along with the bid the deviations if any whether major or minor in the schedule of deviations only. ***In the absence of deviations listed in the schedule of deviations the offer shall be deemed to be in full conformity with the specification "non-withstanding" any thing else stated elsewhere in bidder's offer, data sheets etc. The implied/ indirect deviations in data sheets etc. Shall not be binding on the purchaser.***

13.0 The following documents shall be furnished by the bidder with his offer :

- Compliance certificate duly signed and stamped (Enclosed at Schedules).
- Guarantee schedule duly signed and stamped (Enclosed at Schedules).
- GA drawings of following with empty/ filled-ups.
 - Balls Collecting Strainers (as applicable).
 - Balls recirculating Skids.
 - Other equipments considered necessary for Layout/ Civil.
- Electrical Load Data (Enclosed at Vol. III of Specification)
- Schedule of Deviation (Enclosed at Schedules).

The bidder to note that load requirement furnished and finalised during tender stage shall only be provided by BHEL and any changes or additional requirement of Electrical load by bidder during contract stage shall be provided by BHEL with cost repercussions to the bidder.

NOTE: Apart from above, no other drawing/ document/ data sheet etc. shall be



**TITLE : TECHNICAL SPECIFICATION
FOR
CONDENSER ON LOAD TUBE CLEANING
SYSTEMS (COLTCS)**

SPEC. NO: PE-TS-402-165-N002

VOLUME : II B

SECTION:C1

REV. NO. 0

DATE : 19.05.14

SHEET 9 OF 10

submitted along with the offer. If any drawing/ document etc. is submitted with the offer, same shall be considered as for 'Reference' purpose only and shall not be reviewed/ commented upon and any deviation, exclusion to scope, etc. taken in documents but not highlighted in the deviation schedule shall not be taken cognizance of.



TITLE : TECHNICAL SPECIFICATION
FOR
CONDENSER ON LOAD TUBE CLEANING
SYSTEMS (COLTCS)

SPEC. NO: PE-TS-402-165-N002

VOLUME : II B

SECTION:C1

REV. NO. 0

DATE : 19.05.14

SHEET 10 OF 10

ANNEXURE- I

COLTCS

SL.NO.	Projects	Size (NB)	Length of Ball Separator (Excluding Counter Flange)	Scope of Counter Flange	Scope of Gaskets, nuts and bolts.
1	2X500 MW NNTPS NEW NEYVELI	2200 NB	4400 mm	In Purchaser's Scope.	In Bidder's Scope

Notes:

1. Ball separator shall be mounted directly on the existing Butterfly valve (Please refer Annexure-III).
2. Flap of butterfly valve shall be extended to 800 mm inside the Ball separator (GA of Butterfly valve has been enclosed).

ANNEXURE-I

ALL DIMENSIONS ARE IN MM

FIRST ANGLE PROJECTION

DRAWING NO. PE-DG-999-141-M017

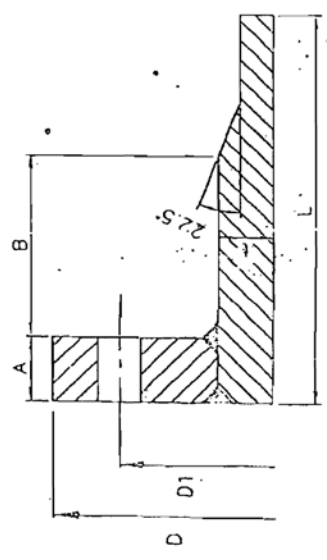

NOTES:-

Flange thicknesses listed are for Design pressure=5kg/cm²(g) and Flange dimensions as given in the table. Final thickness of the flange is to be checked for actual OD/Bolting PCD/Neck dimensions.

PIPE SIZE	PIPE THK.	FLANGE OD 'D'	BOIL PCD 'D1'	WELD NECK FLANGE		SLIP-ON FLANGE THICKNESS
				FLANGE THICK. 'A'	WELD NECK LENGTH 'L'	
1200	10-12	1465	1380	40	70	200
1400	14	1675	1590	50	70	200
1600	14	1915	1920	60	32	80
1800	14-16	2115	2020	70	32	90
2200	18	2550	2420	80	36	100
2300	20			90	38	110
2500	20			90	38	110
2700	20			90	38	110
						325
						325
						150
						150
						150

— TENTATIVE

DRAWING FOR BAL. SEPARATOR COUNTER FLANGE

REV.	DATE	ALTU	CHK	APPD	JOB NO.	STATUS	DISTRIBUTION
					999		
BIHARAT HEAVY ELECTRICALS LTD POWER GROUP PROJECTS ENGINEERING MANAGEMENT PPEL, NOIDA							
DRAWING NO. PE-DG-999-141-M017 SHEET 01 OF 01							
TITLE: COUNTER FLANGE DETAILS							
DRAWING NO. PE-DG-999-141-M017 SHEET 01 OF 01							

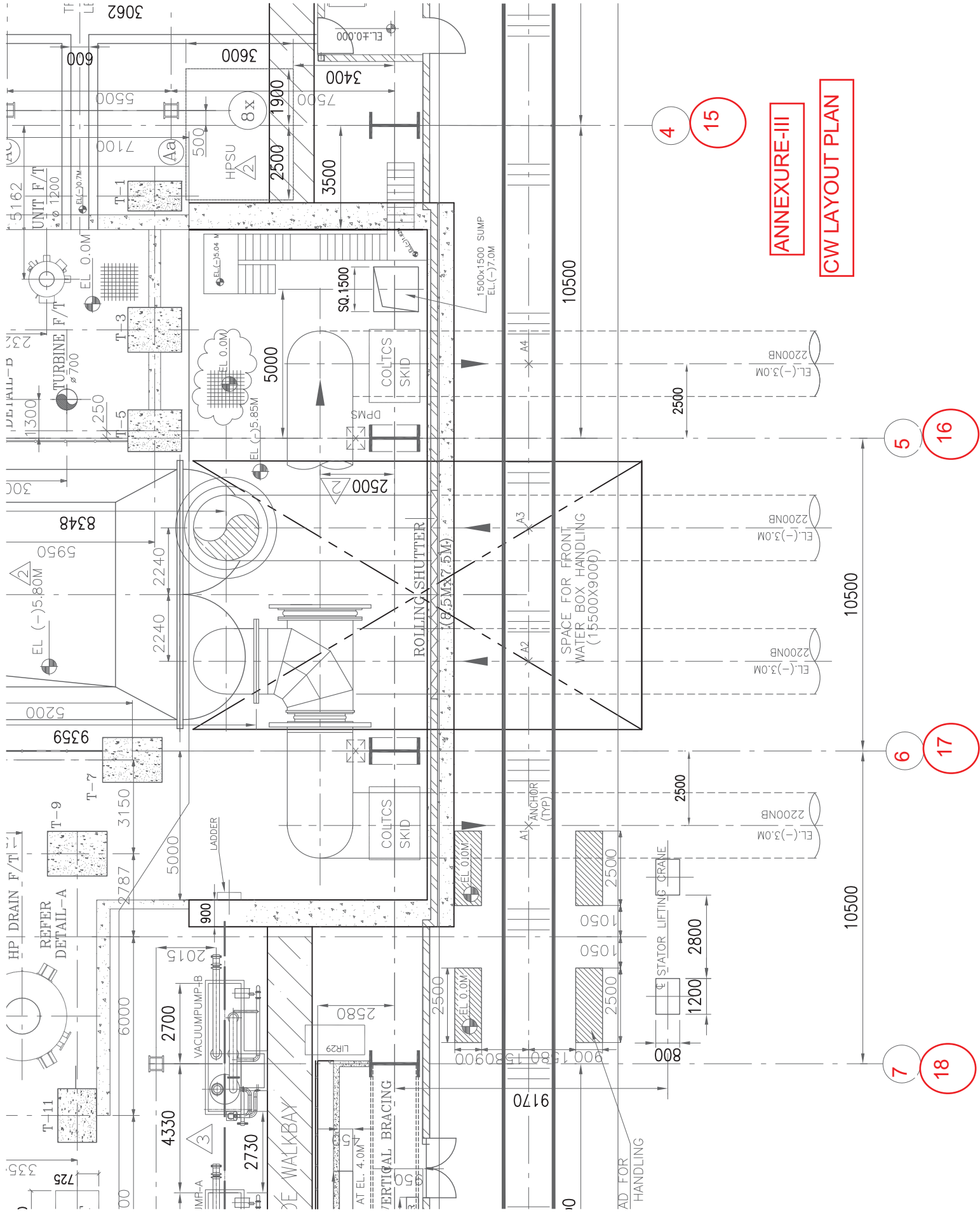

ANNEXURE-III
CW LAYOUT PLAN

4 15

5 16

6 17

7 18

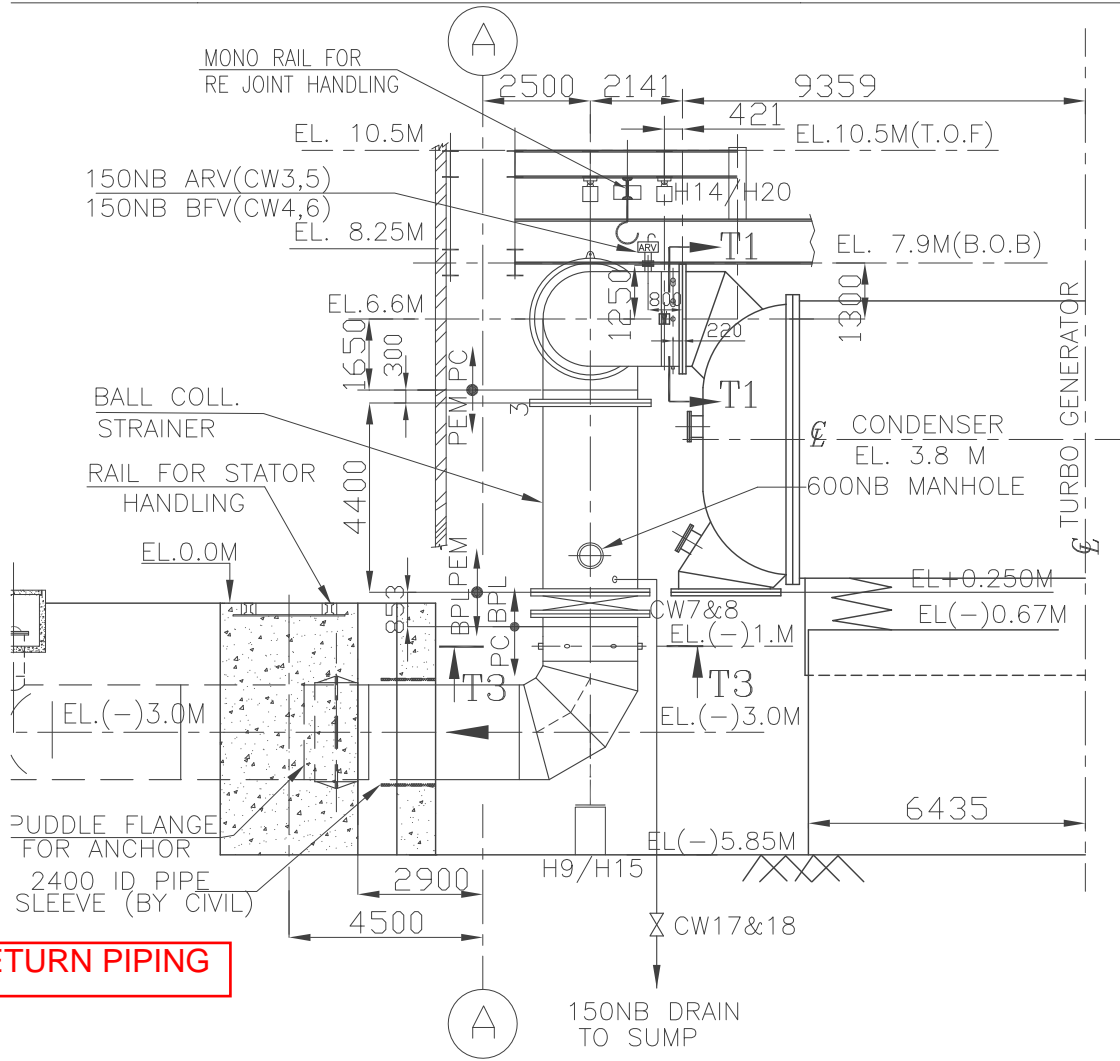

CW RETURN PIPING

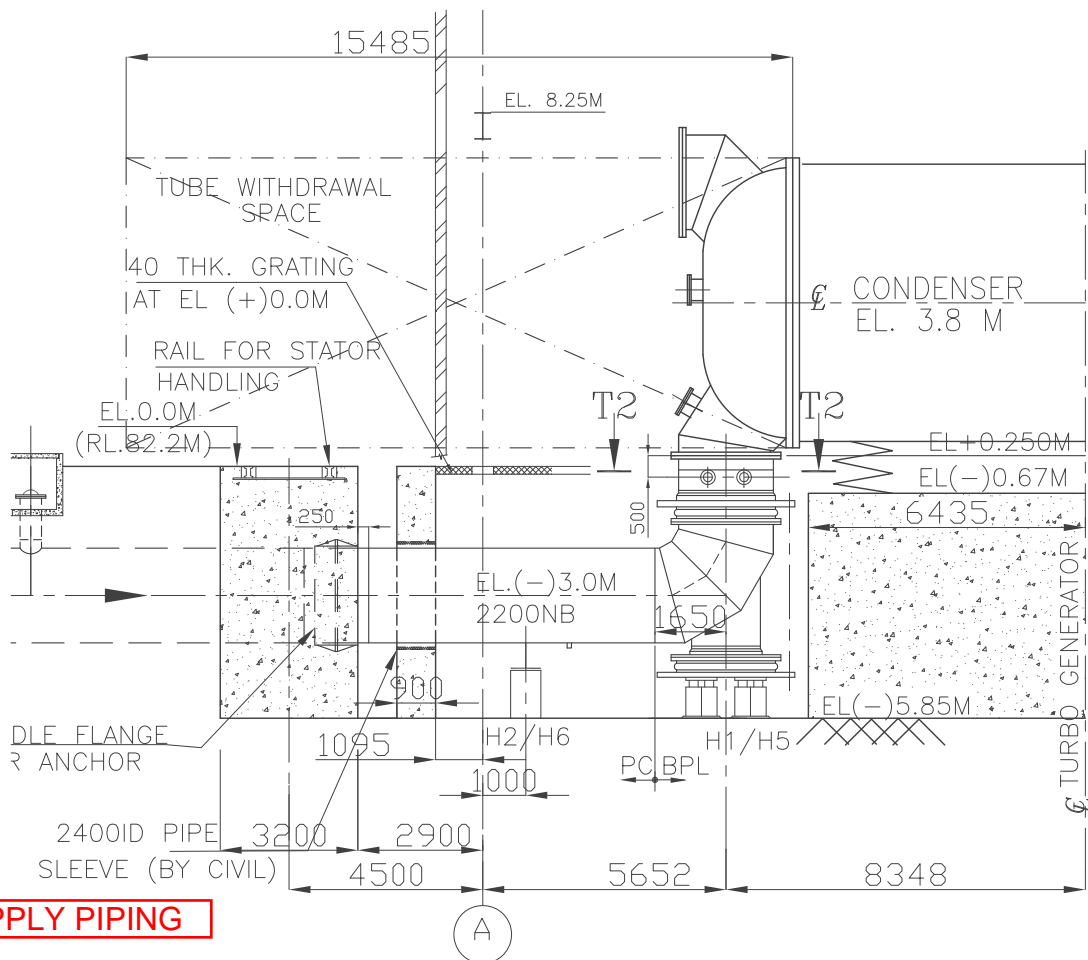

CW SUPPLY PIPING



7.1 GENERAL

The continuous cleaning of condensers maintains the efficiency of heat transfer without mechanical or chemical cleaning of the tubes and without increasing the number of outages. Condenser tube cleaning is necessary as lake water induces different types of fouling which affects the inside of condenser tubes. Settling of suspended materials like silt, mud, slime, biological fouling due to the presence of bacteria/marine organisms in water, crystallization of soluble elements leads to fouling of Condenser Tubes

Cleaning of internal tube surface is done by continuous circulation of sponge rubber balls with sizes slightly larger than the tube diameter. These sponge rubber balls are injected into the cooling water inlet header. The water flow carries these balls into the inlet water boxes, then through the tubes and finally into the ball strainer located at the cooling water outlet header.

7.2 CODES AND STANDARDS

“The design, material, construction, manufacture, inspection, testing and performance of Condenser on-line tube cleaning system and debris filters for Auxiliary system and associated equipment shall comply with the latest edition of all currently applicable standards, statutory regulations and safety codes in the locality where the equipment will be installed. Nothing in this specification shall be construed to relieve the Bidder of his responsibility. In case of conflict between the standards, stringent specifications out of these standards shall govern, whereas in case of conflict between the standards and this specification, requirements of this specification shall govern. Other National standards are acceptable if they are established to be equal to or superior to the listed standards. In all such cases, however, copies of English translation of such National standards shall be attached to the tender. The tenders not complying with this requirement are liable for rejection”.

The design, materials requirement, manufacture, testing and performance requirements of the condenser On Line Tube Cleaning System shall conform to the latest edition of the following codes, standards, specification and regulation:

- a) Standards of the Hydraulic Institute of USA.
- b) PTC 8.2 : Power Test Codes - Centrifugal pumps.
- c) ASME Section VIII: Pressure Vessel Code, 2001
- d) ASTM - American Society for Testing & Materials.
- e) American National Standards (ANSI) on -
 - i. Steel Pipe Flanges and Flanged Fittings (B 16.5)
 - ii. Steel Fittings S.W. and Threaded (B 16.11)
 - iii. Butt welding ends-Pipe, valves, & fittings (B16.25).
 - iv. Valves – Flanged, Threaded and Welding End (B 16.34)
- f) American Society for Non destructive Testing (SNT-TC-1A)

Document Number	Rev No.	Description	Page No.	Date of Issue
LII-GEOE11019-G-00155-002	02	NTA2 Vol - IIA, Sec – VII, COLTCS	129	25-Jun-11



- g) NEMA : National Electrical Manufacturer's Association
- h) OSHA : Occupational Safety and Health Act
- i) IEEE : Institute of Electronics and Electrical Engineers
- j) ISA : Instrument Society of America

7.3 SCOPE OF WORK

The scope of supply under On Line Tube Cleaning System per unit shall be as below. Items not mentioned but deemed necessary by the Bidder for making the system completely reliable and efficient shall also be included:

- a) Condenser On Line Tube Cleaning Systems consisting of -
 - i. Two (2) nos. Ball separator on the C.W. outlet pipes. Each ball separator shall consist of Carbon Steel flanged shell, ball separator screens, ball extraction arrangement; drive units for actuation of screens, differential pressure measuring system etc.
 - ii. Two (2) nos. ball re-circulation units complete with pumps, drive motors, ball collectors, etc.
 - iii. Two (2) nos. Ball Recirculation Monitors and ball injection arrangement.
- b) All interconnecting pipes with necessary valves, fittings, pipe supports etc. for connecting ball separator section to ball re-circulating skid, re-circulating skid to injection point, Debris Filter to debris discharge point on the C.W. outlet pipes at downstream of ball separator, all integral piping for debris flushing system and ball re-circulating skid, drain line, vent line, drain collectors (floor level), sample points with suitable valves etc.
- c) All supporting steel structures for the equipment, piping and instrument for the skid.
- d) All foundation bolts and embedded inserts required for anchorage of machines, equipments, structures, and cable trays.
- e) Required number of cleaning balls (normal sponge balls as well as abrasive balls) for commissioning of the system.
- f) Provision for manual and automatic back wash arrangement with automatic collection of balls prior to back washing shall be made.
- g) Provision of ball monitoring system including ball circulation monitor, oversize monitor and ball sorter shall be made.
- h) The ball collecting strainer shall have differential pressure transmitter with back washing system.
- i) Provision to prevent loss of balls under normal and abnormal operation including tripping of CW pumps shall be made.
- j) The no. of balls in circulation shall be atleast 10% of no. of condenser tubes.
- k) Provision for automatic ball withdrawal from the strainer prior to back washing shall be made.

Document Number	Rev No.	Description	Page No.	Date of Issue
LII-GEOE11019-G-00155-002	02	NTA2 Vol - IIA, Sec – VII, COLTCS	130	25-Jun-11



Other standards such as IEC, VDI, DIN, BS, IS etc. shall also be accepted subject to the Purchaser's approval for which the Bidder shall furnish along with the bid adequate information to justify that these standards are equivalent or superior to the standards mentioned above. For such alternate standards, which are not normally published in English, bidder shall also furnish a complete translation for them.

Technical requirements of the condenser On Line Tube Cleaning System have been indicated in the "Data Sheet" in volume- IIB of the specification. In case of any contradiction between the above standards and data sheets, the stipulations in the data sheet shall prevail and shall be binding on the Bidder.

7.4 PROCESS

For maintenance of degree of cleanliness of the condenser tubes, this on load ball recirculation type tube cleaning system and debris filters at CW inlet line to condenser will be employed. The on line condenser tube cleaning system shall maintain a circulation of resilient balls in a closed loop through the condenser tubes. Thus, while passing through the tubes, the balls get deformed thereby cleaning the inner surface of the tubes. The balls will be injected at the C.W. inlet pipe by ball recirculation pumps, which subsequently will be distributed evenly throughout the cross-section of the condenser tube sheet to effect uniform cleaning of tubes. The balls after passing through the tubes will be taken out of the C.W. outlet pipes. The balls are then led to the C.W. inlet pipe once again for recirculation.

7.5 DESIGN AND MANUFACTURING / CONSTRUCTION REQUIREMENT

Equipment/works offered shall be designed for high availability, high reliability, low maintenance and ease of operation & maintenance. The Bidder shall specifically state the design features incorporated to achieve high degree of reliability, availability, operability and ease of maintenance. He shall also furnish details of availability records in plants stated in his experience list.

All similar parts of the equipment shall be made to gauge and shall be interchangeable with and shall be made of same material and workmanship as the corresponding parts of the equipment. Where feasible common components shall be employed in different pieces of equipment in order to optimize the spares inventory and utilization

7.5.1 General Performance Requirement

- i. The cleanliness of the condenser tubes utilizing continuous operation of the system such that the contribution of the tube waterside fouling to the variation of the condenser vacuum from its design value is negligible.
- ii. The pressure drop across the ball separator screens and debris filter screens during normal cleaning operation shall be minimum.
- iii. In the automatic system, sequential operations of various equipment in tube cleaning system must be performed in such a manner that there is absolutely no loss of balls during any cleaning.

Document Number	Rev No.	Description	Page No.	Date of Issue
LII-GEOE11019-G-00155-002	02	NTA2 Vol - IIA, Sec – VII, COLTCS	131	25-Jun-11



7.5.2 Constructional Features

The equipment shall be capable of safe, reliable and continuous operation at all conditions of circulating water flow through the condenser tubes maintaining the design cleanliness factor of the tubes.

7.5.3 Ball Separator

The design of the ball separator section shall aim at the maximum rigidity of the screens by adequate stiffening bars. The construction of the ball extraction area shall ensure smooth and reliable removal of the balls out of the separator section.

The separator shall have flanged ends and flange drilling shall conform to AWWA C207 standard.

7.5.4 Ball Collector

The size of the ball collector shall be determined by the number of condenser tubes coming per path, the relevant ball circulation frequency and the cleaning ball diameter.

The integral non-return flap shall ensure no reverse flow in case of ball recirculation pump-motor failure thereby avoiding any loss of balls.

7.5.5 Ball injection system

The design of the injection system shall be such that it performs an even distribution of requisite cleaning balls at the C.W. inlet pipe so that each condenser tube receives a cleaning ball regularly at fairly short intervals.

7.5.6 Cleaning balls

Resilient balls of proper hardness and correct size shall be selected based on factors like tube material, nature of fouling expected, tube internal diameter and desired service life of the balls.

Only a single type of ball to cater for the entire range of tube fouling may not adequate. The supplier shall furnish different types of balls as required in sufficient quantities to take care of all possibilities like (a) normal maintenance of tube cleanliness when function of the ball is more of that of polishing than removing of scales (b) removal of comparatively hard scale formed due to non-availability of the tube cleaning system for reasons like failure of the system, long shutdown of the generation unit, etc.

7.5.7 Schedule of Materials

Materials of construction of components of various equipment covered by this specification shall be as per data specification sheet.

In selecting materials of construction of equipment, the Bidder shall pay particular attention to the atmospheric conditions existing at the Site and the nature of material/fluid handled. Wherever deviations are taken in respect of materials specified, the reasons shall be spelt out clearly in the proposal.

Document Number	Rev No.	Description	Page No.	Date of Issue
LII-GEOE11019-G-00155-002	02	NTA2 Vol - IIA, Sec – VII, COLTCS	132	25-Jun-11



All materials shall be new, and shall be of the quality most suited to the proposed application.

In as far as is possible, materials shall be in accordance with national or international standard specifications and shall be used in accordance with national or international codes of practice. Where such standards or codes of practice are not available sufficient information shall be provided to allow the Purchaser to assess the suitability of the material for the particular application.

All materials used shall have demonstrated lengthy satisfactory service in similar or more arduous conditions to those proposed by the Bidder

7.6 INSPECTION AND TESTING

The manufacturer shall conduct all tests and inspections (including stage inspections, as necessary) required to ensure that the equipment offered by him conforms to the requirement of this specification. The particulars of the proposed tests and the procedures for the tests shall be submitted to the Purchaser for approval before conducting tests.

Test certificates for all tests shall be submitted to the purchaser for approval

Document Number	Rev No.	Description	Page No.	Date of Issue
LII-GEOE11019-G-00155-002	02	NTA2 Vol - IIA, Sec – VII, COLTCS	133	25-Jun-11



**TITLE : TECHNICAL SPECIFICATION
FOR
CONDENSER ON LOAD TUBE CLEANING
SYSTEMS (COLTCS)**

SPEC. NO. PE-TS- 402-165-N002

VOLUME : IIB

SECTION : D

REV. NO. 0

**DATE :
19.05.2014**

SHEET 1 of 1

**SECTION C2
CONDENSER ONLOAD TUBE CLEANING SYSTEMS
(ELECTRICAL DETAILS)**



TECHNICAL SPECIFICATION FOR
COLTCS
(ELECTRICAL PORTION)

SPECIFICATION NO.
VOLUME II B
SECTION-C
REV DATE 13.05.2014
PAGE 1 OF 1

SPECIFIC TECHNICAL REQUIREMENTS: ELECTRICAL

1.0 EQUIPMENT & SERVICES TO BE PROVIDED BY BIDDER/ PURCHASER

- 1.1 Scope for supply, and erection & commissioning of various equipment forming part of electrical system for this package shall be as per Annexure-I to Section – C [Scope of Work (Electrical)].
- 1.2 Make of various equipment/ items in the scope of bidder shall be to approval of owner during detailed engineering stage without any commercial implications.
- 1.3 Bidder shall furnish all AC as well as DC loads required for the system at different voltage levels (eg. 415V AC, 240 V AC, 220 V DC etc.) of all types, such as motor feeders, supply feeders in PEM format along with the offer.
- 1.4 All electrical equipment shall be suitable for the power supplies, fault levels and climatic conditions indicated in project information enclosed with the specification.
- 1.5 All drawings, data sheets, Quality Plan, calculations, test reports, test certificates, etc. shall be submitted during detailed engineering stage as per formats enclosed. The same shall be subject to approval without any commercial implications.
- 1.6 Technical requirements shall be as per specifications listed in Clause 4.1, 4.2 & 4.3 below.

3.0 DOCUMENTS TO BE SUBMITTED ALONG WITH BID

- 3.1 Bidder shall confirm total compliance to the electrical specification without any deviation from the technical/ quality assurance requirements stipulated. In line with this, the bidder as technical offer shall furnish two signed and stamped copies of the following:
 - a) A copy of this sheet "Electrical Equipment Specification for COLTCS and sheet "Electrical Scope between BHEL and Vendor" with bidder's signature and company stamp.
 - b) List of Erection and Commissioning spares.
 - c) List of Erection & Maintenance tools & tackles.
 - d) Electrical load requirement in the load data format.
- 3.2 No technical submittal such as copies of data sheets, drawings, write-up, quality plans, type test certificates, technical literature, etc, is required during tender stage. Any such submission even if made, shall not be considered as part of offer.

4.0 LIST OF ENCLOSURES

- 4.1 Electrical scope between BHEL & vendor (Annexure-I).
- 4.2 Technical specification no. PE-SS-999-506-E101, Data Sheets (A & C) for 415V Electric Motors.
- 4.3 Quality Plan for motors.
- 4.4 Load data format (Annexure-II).

ANNEXURE – I TO SECTION – C: STANDARD ELECTRICAL SCOPE BETWEEN BHEL AND VENDOR

PACKAGE: COLTCS

PROJECT: 2X500 MW NNTPS TPP

S.NO	DETAILS	SCOPE SUPPLY	SCOPE E&C	REMARKS
1	415V MCC	BHEL ^{\$}	BHEL ^{\$}	1. 415 V AC/240 V AC supply shall be provided by BHEL based on load data provided by vendor at contract stage for all equipment supplied by vendor as part of contract including power supply equipment (battery charger etc) required for the PLC/control panel (as applicable) for the system supplied by vendor. 2. Interposing relays (RE 302 of Jyoti make or equivalent), if required for PLC and microprocessor based systems, shall be provided by BHEL in MCCs. Requirement of these relays shall be furnished by vendor during detailed engineering stage.
2	Local Push Button Station (for motors)	BHEL ^{\$}	BHEL ^{\$}	Located near the motor.
3	Power cables, control cables and screened control cables for a) both end equipment in BHEL's scope b) both end equipment in vendor's scope c) one end equipment in vendor's scope	BHEL ^{\$} Vendor BHEL ^{\$}	BHEL ^{\$} Vendor BHEL ^{\$}	1. Sizes and quantity of cables required shall be informed by vendor at contract stage (based on inputs provided by BHEL). Finalisation of cable sizes shall be done by BHEL. Vendor shall provide lugs & glands accordingly. 2. Laying of cables by BHEL except for cabling in vendor scope. 3. Termination at BHEL equipment terminals by BHEL. 4. Termination at Vendor equipment terminals by Vendor.
4	Any special type of cable like compensating, co-axial, prefab, MICC, fibre optical etc.	Vendor	Vendor	
5	Cable trays, accessories & cable trays supporting system	BHEL ^{\$}	BHEL ^{\$}	
6	Cable glands and lugs for equipments supplied by Vendor	Vendor	Vendor	1. Double compression Ni-Cr plated brass cable glands 2. Solder less crimping type heavy duty tinned copper lugs for power cables 3. Solder less crimping type heavy duty copper lugs for control cables.
7	Conduit and conduit accessories for cabling between equipments supplied by vendor	Vendor	Vendor	Conduits shall be medium duty, hot dip galvanised cold rolled mild steel rigid conduit as per IS: 9537. Makes of conduits shall be subject to customer/ BHEL approval at contract stage.
8	Lighting	BHEL ^{\$}	BHEL ^{\$}	
9	Equipment grounding & lightning protection	BHEL ^{\$}	BHEL ^{\$}	
10	Below grade grounding	BHEL ^{\$}	BHEL ^{\$}	
11	LT Motors with base plate and foundation hardware	Vendor	Vendor	Makes shall be subject to customer/ BHEL approval at contract stage.
12	Mandatory spares	Vendor	-	Vendor to quote as per specification.
13	Recommended O & M spares, E & C spares, erection &	Vendor	-	As per specification

ANNEXURE – I TO SECTION – C: STANDARD ELECTRICAL SCOPE BETWEEN BHEL AND VENDOR

PACKAGE: COLTCS

PROJECT: 2X500 MW NNTPS TPP

S.NO	DETAILS	SCOPE SUPPLY	SCOPE E&C	REMARKS
	maintenance tools & tackle.			
14	Any other equipment/material/service required for completeness of system but not specified above (to ensure trouble free and efficient operation of the system).	Vendor	Vendor	
15	a) Input cable schedules (C & I) b) Cable interconnection details for above c) Cable block diagram	Vendor Vendor Vendor	- - -	Cable listing for C & I systems for vendor supplied equipment shall be furnished during detail engineering by vendor in soft copies in the BHEL cable schedule format.
16	Equipment layout drawings	Vendor	-	For ensuring cabling requirements are met, vendor shall furnish layout drawings (both in print form as well as in AUTOCAD) of the complete plant (including electrical area) indicating location and identification of all equipments requiring cabling, and shall incorporate cable trays routing details marked on the drawing as per PEM interface comments. Electrical equipment layout drawing shall be to BHEL approval.
17	Electrical Equipment GA drawing	Vendor	-	For necessary interface review.

NOTES:

1. Make of all electrical equipments/items supplied shall be reputed make & shall be subject to approval of BHEL/customer after award of contract.
2. All QPs shall be subject to approval of BHEL/customer after award of contract without any commercial implication.
3. For skid mounted system, 2 nos. (1W+1S) supply of 415 V, 3 phase, 4 wire AC shall be provided by BHEL/Customer. Complete skid including changeover between feeder/starters/LCP/inter-locks/protection devices / any other supply etc. shall be in bidder's scope only.
4. Painting: The painting for electrical equipment shall be epoxy based with suitable additives. The paint shall be corrosion proof epoxy based of approved class and paint thickness shall be within 100 to 150micron. The vendor shall furnish the complete painting details during detailed engineering.
5. \$: Shall be in customer scope where equipment are supplied by customer.

SPECIFIC ELECTRICAL REQUIREMENT FOR COLTCS

SL.NO.	PARAMETERS	UNIT	NLC
	MOTOR		
1	DESIGN AMBIENT TEMP	DEG. C	50
2	VOLTAGE SUPPLY AND VARIATION	VOLT	415V, \pm 10%
3	FREQUENCY WITH VARIATION	Hz	50 (+) 5% to (-) 3%
4	COMBINED VOLTAGE & FREQUENCY VARIATION		10%
5	MAX ACCEPTABLE RATING OF MOTOR AT 415 V	KW	160 KW & below
6	SYSTEM FAULT LEVEL AND ITS DURATION	KA	50kA, 1sec
7	SUTABILITY OF TERMINAL BOX FOR FAULT LEVEL AND DURATION		50 KA, 0.25 sec
8	CLASS OF INSULATION & TEMP RISE LIMITED TO		Class-F or better and temp rise limited to Class-B
9	MIN. STARTING VOLTAGE		85%
10	MOTOR RATING FOR SINGLE PHASE SUPPLY		0.22 kW & Below
11	MAXIMUM LOCKED ROTOR CURRENT	% OF FLC	As per IS 12615
12	ACCEPTABLE NOISE LEVEL	DB	Noise level for all motors shall be limited to 85dB(A) at 1.5 m (in line with IS 12065)
13	TYPE OF STARTER PROVIDED IN MCC		DOL
14	DOP OF ENCLOSURE		IP-55 FOR OUTDOOR & IP-54 for indoor resp.
15	SPACE HEATER REQUIREMENT	<30kW	30KW & ABOVE
16	PAINT SHADE		DURING DETAIL ENGINEERING.
17	ENERGY EFFICIENT		(I) ENERGY EFFICIENT TYPE IE1 AS PER IS 12615 (II) For LT Motors above 50kW, type test reports for type tests as per IS: 325/ IS: 12615 conducted on equipment similar to those proposed to be supplied and carried out within last five years from the date of bid opening viz. February 2012 shall be submitted. However, if such reports are not available, one motor of each type shall be subjected to type tests for free of cost.



**TITLE : TECHNICAL SPECIFICATION
FOR
CONDENSER ON LOAD TUBE CLEANING
SYSTEMS (COLTCS)**

SPEC. NO. PE-TS- 402-165-N002

VOLUME : IIB

SECTION : D

REV. NO. 0

**DATE :
19.05.2014**

SHEET 1 of 1

**SECTION C3
CONDENSER ONLOAD TUBE CLEANING SYSTEMS
(C&I DETAILS)**

**C&I SPECIFICATION FOR COLTCS
FOR NEW NEYVELLI TPP (TG PACKAGE)**



7.9.1 On-line Condenser Tube Cleaning System (OLCTCS)

PLC based system is envisaged for OLCTCS. The PLC & Complete instrumentation system required for this is in the scope of TG Contractor. The system described hereunder is indicative only for Contractor's guidance. The Contractor shall design system for safe & trouble free operation. The PLC shall be linked to plant DCS via soft link for monitoring of the operation of OLCTCS.

Operation of the condenser on-line tube cleaning system & debris filter with necessary audio visual alarm/indications shall be implemented in PLC based Local Control Panel. The system shall be controlled either in manual or Auto mode. Following major control logics are envisaged, however Contractor shall provide required control features for safe & trouble free operation. Provision for manual override of any automatic operation shall be made available in control panel. Potential free contacts shall be provided for interfacing with MCC & other systems.

1. Start-up of the cleaning system after manually feeding the requisite number of balls into the collector. The above operation shall be achieved by setting the control switch in Auto mode & pressing the System 'ON' Pushbutton. Other steps will follow sequentially viz. tilting of the screens in the strainers to ball circulating position, starting the recirculation pumps, turning the ball catching Flap in the collector to ball circulation position, etc. In case of manual, all steps shall be achieved manually by pressing the respective pushbuttons.
2. Automatic shutdown of cleaning system either automatically or as required by operator by pressing the stop pushbutton from the local control panel. Under Auto mode, pushing the 'OFF' pushbutton shall initiate the above operation through steps like turning the ball catching flap in the collector to ball catching position, stopping the recirculation pump after a set period.
3. Monitoring of strainer section screen fouling by differential pressure measuring systems.
4. Following indicators minimum shall be provided on Local Control Panel:
 - Tube cleaning system 'ON' & 'OFF' status
 - Recirculation pump 'ON' & 'OFF' status
 - Screen in operation
 - DP high & normal status
 - MOV open & close status
 - Various equipments failure indications
5. Following Alarms minimum shall be provided on Local Control Panel:
 - Recirculation Pump Tripped



- DP high/ very high
- MOV fail to Open or Close
- Screen actuator failure

7.9.2 Condensate Polishing unit (CPU)

PLC based system is envisaged for CPU & its Regeneration System. The PLC & Complete instrumentation system required for this is in the scope of TG Contractor. The system described hereunder is indicative only for Contractor's guidance. The Contractor shall design system for safe & trouble free operation. The PLC shall be linked to plant DCS via soft link for monitoring the operation of CPU & Regeneration System.

Operation of the CPU with necessary audio visual alarm/indications shall be implemented in PLC based Local Control Panel system & shall be provided with LCD based operator work station that will clearly show the status of each service vessel. Following major control logics are envisaged, however Contractor shall provide required control features for safe & trouble free operation. Provision for manual override of any automatic operation shall be made available in control panel. Potential free contacts shall be provided for interfacing with MCC & other systems. This panel shall be located near the respective condensate polishing vessels.

1. Service Mode

- Flow transmitter shall be provided for monitoring flow rate for each polishing vessel. If condensate flow is low the operator can initiate automatic sequence to remove one of the vessels from service.
- DP transmitters shall be provided to monitor/alarm high pressure drop across the inlet & outlet of the vessel. The bypass system shall initiate automatically.
- Conductivity analyzer shall be provided at the outlet of each vessel to monitor the quality of condensate & to initiate the regeneration cycle.
- When the vessel under Service mode is ready for regeneration, the operator shall change the same into "Isolation mode" in the panel. Subsequently the "Standby vessel" shall be selected for "Service mode" from the OWS/control panel. The selection shall follow, required sequence as per pressurization of the vessel, checking of the condensate quality and putting the vessel in service on satisfactory condensate quality.
- Normally "Service vessel" once exhausted shall be isolated from service till the "Regeneration" operation is complete. In addition, provision shall be kept for isolation of one or all the vessels from service if required by operator from the panel.

CONDENSER ON LOAD TUBE CLEANING SYSTEM - C&I REQUIREMENTS		
S.NO.	PROJECT	NEW NEYVELLI (TG)
1.00	SYSTEM	COLTCS
2.00	COMMON / PER UNIT	REFER NOTES
3.00	CONTROL SYSTEM	PLC
3.10	PROCESSOR CONFIGURATION FOR PLC SYSTEM	REDUNDANT WITH HOT STAND BY
4.00	LOCATION OF CONTROL SYSTEM	LOCAL TO COLTCS
4.10	CONTROL SYSTEM SCOPE (BIDDER/ BHEL/ CUSTOMER)	BIDDER
5.00	HARDWIRED INTERFACE WITH DCS (Y/N)	Y
5.10	PURPOSE OF HARDWIRED INTERFACE WITH DCS	FOR FAULT CONTACTS
5.11	a) COMMAND FROM DCS (Y/N)	N
5.12	b) STATUS FEEDBACK TO DCS (Y/N)	N
5.13	c) GROUP FAULT ALARM TO DCS (Y/N)	Y
6.00	SOFTLINK TO DCS (Y/N)	Y
6.10	PURPOSE OF SOFTLINK TO DCS	MONITORING
6.11	a) COMMAND INTERFACE WITH DCS (Y/N)	N
6.12	b) STATUS MONITORING IN DCS (Y/N)	Y
7.00	PROTECTION CLASS FOR PLC / RIO PANEL	IP54
8.00	CONTROL FROM PB's ON LCP/OWS	CONTROL FROM PB's ON LCP
9.00	ANNUNCIATION ON LCP (Y/N) -- IF Y, MIN NO. OF HARDWIRED ALARMS / INDICATIONS	YES- BIDDER TO PROPOSE MIN. NO. OF ALARMS/INDICATIONS
9.10	MIMIC ON LCP (Y/N)	Y

CONDENSER ON LOAD TUBE CLEANING SYSTEM - C&I REQUIREMENTS		
S.NO.	PROJECT	NEW NEYVELLI (TG)
10.00	CONTROL FROM DCS IN CCR (Y/N)	N
11.00	TYPE OF SOFTLINK (TP/OFC)	OFC
11.10	COMMUNICATION CABLE SCOPE (BIDDER/ BHEL)	BIDDER
11.20	REDUNDANT CABLE (Y/N)	Y
11.30	PROTOCOL	OPC
12.00	RIO / RPU (Y/N)	N
13.00	## NO. OF OWS / LAPTOP/LCD	A) 1 NO. LAPTOP PER PLC LOADED WITH ENGG. S/W B) 1 NO. OF LCD DISPLAY ON EACH PLC PANEL .
13.10	SIZE OF OWS/ CRT OR LCD	15" LCD
14.00	NO. OF PRINTER	N
14.10	PRINTER SIZE AND TYPE	NA (COLOR LASER)
15.00	POWER SUPPLY AVAILABLE FOR BALL MONITOR (24V DC / 110 V AC UPS / 230 V AC UPS)	A) 230 V AC UPS B) 24VDC TO BE DERIVED FROM PLC PANEL
15.10	&& POWER SUPPLY AVAILABLE FOR PLC PANEL (3PHASE, 415 V AC/ 1PHASE, 110 V UPS/ 1PHASE, 230 V UPS)	3 PHASE, 415 V AC AT SINGLE POINT
15.20	REDUNDANT FEEDERS (R) / NON-REDUNDANT (NR) FEEDERS FOR POWER SUPPLY	R
15.30	**UPS BATTERY CONFIGURATION (1X100% / 2X100%)	2 X 100 %
15.40	BATTERY TYPE (LEAD ACID/ Ni-Cd)	Lead Acid 'Plante' type
15.50	BATTERY BACK-UP TIME (in minutes)	30
16.00	ACTUATOR WITH INTEGRAL STARTER (Y/N)	N
17.00	PG/ DPG/ PS/ DPS/ PT/ DPT per Balls Collecting Strainer/DF/SCS	DPT = 2 nos. DPI = 1 no.(ACROSS EACH BALL SEPARATOR)

CONDENSER ON LOAD TUBE CLEANING SYSTEM - C&I REQUIREMENTS

S.NO.	PROJECT	NEW NEYVELLI (TG)
19.00	PROJECT SPECIFIC INFO	Y
20.00	REMARKS	1) DISTANCE BETWEEN CCR AND THE PLC PANEL WILL BE AROUND 150 METRES.
21.00	NOTES:	
	1. && ALL POWER SUPPLY REQUIREMENTS FOR INDIVIDUAL SUB-SYSTEMS/ COMPONENTS EG. BALL MONITOR, SOL VALVES ETC SHALL BE DERIVED BY THE VENDOR FROM THIS POWER SUPPLY.	
	2. ** THE UPS FOR PLC SHALL BE IN BIDDER'S SCOPE WITH 2X100% CONFIGURATION.	
	3. BIDDER TO PROVIDE INPUT/OUTPUT LIST, DRIVES LIST, JUNCTION BOX SCHEDULE AND TERMINATION DETAILS, RECOMMENDED CONTROL LOGICS / WRITE-UP ETC. DURING DETAILED ENGINEERING	
	4. ALL CABLES & CABLE ENGINEERING SHALL BE IN BIDDER'S SCOPE.	
	5. ## LAPTOPS SHALL BE OF LATEST CONFIGURATION WITH PROGRAMMING SOFTWARE & COMMUNICATION CABLE.	
	6. 2 SETS OF COLTCS SHALL HAVE ONE COMMON STARTER PANEL (SWITCH GEAR PANEL) CUM PLC PANEL. THIS SHALL ALSO SERVE AS THE LCP FOR 1 SET OF COLTCS. HOWEVER, SEPARATE LCP PROVIDED FOR OTHER SET OF COLTCS.	
	7. COLOUR OF THE PANELS SHALL BE RAL 7035 FOR EXTERIOR & BRILLIANT WHITE FOR INTERNAL. THIS SHALL BE DECIDED DURING DETAIL ENGINEERING	
	8. INSTRUMENT RACK AND JUNCTION BOXES SHALL BE IN BIDDER'S SCOPE OF SUPPLY.	
	9. BIDDER TO FURNISH ELECTRICAL LOAD DATA DURING DETAILED ENGINEERING.	
	10. ALARM FACIA SHALL BE UNDER BIDDER'S SCOPE. NUMBER OF FACIA SHALL BE DECIDED DURING DETAILED ENGINEERING.	
	11. PLC BASED CONTROL SYSTEM SHALL BE PROVIDED UNIT WISE. THE PLC SYSTEM SHALL BE PROVIDED WITH NECESSARY INTERFACE HARDWARE AND SOFTWARE FOR DUAL FIBER OPTIC CONNECTIVITY INCLUDING LIU (LIGHT INTERFACE UNIT), PATCH CORDS ETC. AT PLC END FOR INTERCONNECTION WITH DDCMIS LOCATED AT MAIN PLANT CONTROL ROOM FOR MONITORING OF SIGNAL INFORMATION.	
	LEGEND:	
	CCR- COMMON CONTROL ROOM	
	DCS- DISTRIBUTED CONTROL SYSTEM	
	PLC- PROGRAMMABLE LOGIC CONTROLLER	
	RPU - REMOTE PROCESSING UNIT	

	SPECIFICATION FOR MOTORISED VALVE ACTUATOR		SPECIFICATION NO.:	
			VOLUME	
			SECTION	
			REV. NO.	DATE:
			SHEET	1 OF 3
Data Sheet A & B				
DATA SHEET-A (TO BE FILLED BY PURCHASER)			DATA SHEET-B (TO BE FILLED-UP BY BIDDER)	
GENERAL*	* PROJECT			
	OFFER REFERENCE			
	* TAG NO. SERVICE			
	* DUTY	<input type="checkbox"/> ON / OFF	<input type="checkbox"/> INCHING	
	* LINE SIZE (inlet/outlet): MATERIAL			
	* VALVE TYPE	<input type="checkbox"/> GLOBE <input type="checkbox"/> GATE <input type="checkbox"/> REG. GLOBE <input type="checkbox"/> BUTTERFLY		
	* OPENING / CLOSING TIME			
	* WORKING PRESSURE			
	AMBIENT CONDITION	SHALL BE SUITABLE FOR CONTINUOUS OPERATION UNDER AN AMBIENT TEMP. OF 0-55 DEG C AND RELATIVE HUMIDITY OF 0-95%		
	VALVE SEAT TEST PRESS	BIDDER TO SPECIFY		
	REQUIRED VALVE TORQUE	BIDDER TO SPECIFY		
	ACTUATOR RATED TORQUE	BIDDER TO SPECIFY		
CONSTRUCTION AND SIZING	CONSTRUCTION	TOTALLY ENCLOSED, DUST TIGHT, WEATHER PROOF, IP:67		
	MECHANICAL POSITION INDICATOR	TO BE PROVIDED FOR 0-100% TRAVEL		
	BEARINGS	DOUBLE SHIELDED, GREASE LUBRICATED ANTI-FRICTION.		
	GEAR TRAIN FOR LIMIT SWITCH/TORQUE SWITCH OPERATION	METAL (NOT FIBRE GEARS). SELF-LOCKING TO PREVENT DRIFT UNDER TORQUE SWITCH SPRING PRESSURE WHEN MOTOR IS DE-ENERGIZED.		
	SIZING	OPEN/CLOSE AT RATED SPEED AGAINST DESIGNED DIFFERENTIAL PRESSURE AT 90% OF RATED VOLTAGE. FOR ISOLATING SERVICE THREE SUCCESSIVE OPEN-CLOSE OPERATIONS OR 15 MINS. WHICHEVER IS HIGHER. FOR REGULATING SERVICE - 150 STARTS/HR MINIMUM		
HANDWHEEL	* REQUIRED	<input checked="" type="checkbox"/> YES	<input type="checkbox"/> NO	
	* ORIENTATION	<input type="checkbox"/> TOP MOUNTED	<input type="checkbox"/> SIDE MOUNTED	
	*TO DISENGAGE AUTOMATICALLY DURING MOTOR OPERATION.			
ELECTRIC ACTUATOR	ACTUATOR MAKE/MODEL	BIDDER TO SPECIFY		
	MOTOR MAKE / MODEL / TYPE / RATING (KW)	BIDDER TO SPECIFY		
	@ MOTOR TYPE	IE1 TYPE AS PER IS: 12615, SQUIRREL CAGE INDUCTION MOTOR SUITABLE FOR DOL STARTING.		
	ACTUATOR APPLICABLE WIRING DIAGRAM	<input checked="" type="checkbox"/> ENCLOSED (BIDDER TO CONFIRM) <input checked="" type="checkbox"/> DRG. NO. 4-V-MISC-90271 R11		
	COLOUR SHADE	<input checked="" type="checkbox"/> BLUE (RAL 5012), To be decided during detail engg.		
	PAINT TYPE (## Refer Notes)	<input type="checkbox"/> ENAMEL	<input checked="" type="checkbox"/> EPOXY	<input type="checkbox"/>
	SHAFT RPM	BIDDER TO SPECIFY		
	OLR SET VALUE	BIDDER TO SPECIFY		
	@ STARTING / FULL LOAD CURRENT	600% OF FLC INCLUSIVE OF I.S. TOLERANCE		
	NO. OF REV FOR FULL TRAVEL	BIDDER TO SPECIFY		
	@ PWR SUPP TO MTR / STARTER	415V, 3PH, AC	DOL STARTER	
	@ CONTROL VOLTAGE REQUIREMENT	TO BE DERIVED FROM THE POWER SUPPLY TO THE STARTER <input type="checkbox"/> 230 V <input type="checkbox"/> 110 V		
	@ ENCLOSURE CLASS OF MOTOR	<input checked="" type="checkbox"/> IP 67 <input type="checkbox"/> FLAME PROOF		
	@ INSULATION CLASS	CLASS-F TEMP. RISE LIMITED TO CLASS-B		

	SPECIFICATION FOR MOTORISED VALVE ACTUATOR		SPECIFICATION NO.:		
			VOLUME		
			SECTION		
			REV. NO.	DATE:	
			SHEET	2	OF
Data Sheet A & B					
DATA SHEET-A (TO BE FILLED BY PURCHASER)				DATA SHEET-B (TO BE FILLED-UP BY BIDDER)	
	@ WINDING TEMP PROTECTION	<input checked="" type="checkbox"/> THERMOSTAT (3 Nos.,1 IN EACH PHASE) <input type="checkbox"/> -----			
	SINGLE PHASE / WRONG PHASE SEQUENCE PROTECTION	REQUIRED			
INTEGRAL STARTER	INTEGRAL STARTER	<input type="checkbox"/> REQUIRED <input checked="" type="checkbox"/> NOT REQUIRED			
	TYPE OF SWITCHING DEVICE	<input type="checkbox"/> CONTACTORS <input type="checkbox"/> THYRISTORS			
	TYPE	<input type="checkbox"/> CONVENTIONAL <input type="checkbox"/> SMART (NON-INTRUSIVE)			
	IF SMART				
	a) SERIAL LINK INTERFACE	<input type="checkbox"/> INTEGRAL <input type="checkbox"/> FIELD MOUNTED			
	b) SERIAL LINK PROTOCOL	<input type="checkbox"/> FOUNDATION FIELD-BUS <input type="checkbox"/> PROFI-BUS <input type="checkbox"/> DEVICE NET <input type="checkbox"/>			
	c) SERIAL LINK MEDIA	<input type="checkbox"/> TWISTED PAIR Cu-CBL <input type="checkbox"/> CO-AXIAL Cu-CBL <input type="checkbox"/> OFC			
	d) HAND HELD PROGRAMMER	<input type="checkbox"/> REQUIRED <input type="checkbox"/> NOT REQUIRED			
	e) TYPE OF HAND HELD PROGRAMMER	<input type="checkbox"/> BLUETOOTH <input type="checkbox"/> INFRARED <input type="checkbox"/>			
	f) MASTER STATION	<input type="checkbox"/> REQUIRED <input type="checkbox"/> NOT REQUIRED			
	g) MASTER STN INTRFACE WITH DCS	<input type="checkbox"/> MODBUS <input type="checkbox"/> TCP/IP			
	h) DETAILS OF SPECIAL CABLE	<input type="checkbox"/> ENCLOSED <input type="checkbox"/> NOT REQUIRED			
	STEP DOWN CONT. TRANSFORMER	<input type="checkbox"/> REQUIRED			
	OPEN / CLOSE PB	<input type="checkbox"/> REQUIRED <input type="checkbox"/> NOT REQUIRED			
	STOP PB	<input type="checkbox"/> REQUIRED <input type="checkbox"/> NOT REQUIRED			
	INDICATING LAMPS	<input type="checkbox"/> REQUIRED <input type="checkbox"/> NOT REQUIRED			
	LOCAL REMOTE S/S	<input type="checkbox"/> REQUIRED <input type="checkbox"/> NOT REQUIRED			
STATUS CONTACTS FOR MONITORING	<input type="checkbox"/> REQUIRED <input type="checkbox"/> NOT REQUIRED				
INTEGRAL STARTER DISTURBED SIGNAL	REQUIRED (O/L RELAY OPERATED, CONT./POWER SUPPLY FAILED, S/S IN LOCAL, TORQUE SWITCH OPTD. MID WAY)				
INTERPOSING RELAY/OPTO COUPLER (Applicable for integral Starter)	TYPE OF ISOLATING DEVICE	<input type="checkbox"/> INTERPOSING RELAY <input type="checkbox"/> OPTO COUPLER <input type="checkbox"/> EITHER			
	QUANTITY	<input type="checkbox"/> 2 NOs. <input type="checkbox"/> 3 NOs.			
	DRIVING VOLTAGE	<input checked="" type="checkbox"/> 20.5 – 24V DC <input type="checkbox"/> _____ V DC			
	DRIVING CURRENT	<input checked="" type="checkbox"/> 125mA MAX <input type="checkbox"/> _____ mA MAX			
	LOAD RESISTANCE	<input checked="" type="checkbox"/> > 192 ohms - <25 k ohms <input type="checkbox"/> > _____ ohms - < _____ ohms			
TORQUE SWITCH (Not Applicable for Smart Actuator) (\$\$ Refer Notes)	MFR & MODEL NO.	BIDDER TO SPECIFY			
	OPEN / CLOSE	<input checked="" type="checkbox"/> 1 No. <input type="checkbox"/> 2Nos. / <input checked="" type="checkbox"/> 1 No. <input type="checkbox"/> 2Nos			
	CONTACT TYPE	2 NO + 2 NC			
	RATING	5A 240V AC AND 0.5A 220V DC			
	CALIBRATED KNOBS(OPEN&CLOSE TS)	REQUIRED FOR SETTING DESIRED TORQUE			
	ACCURACY	+3% OF SET VALUE			
LIMIT SWITCH (Not Applicable for Smart Actuator) (\$\$ Refer Notes)	MFR & MODEL NO.	BIDDER TO SPECIFY			
	OPEN : INT : CLOSE	<input checked="" type="checkbox"/> 1 No <input type="checkbox"/> 2 Nos. <input type="checkbox"/> 2 Nos. (ADJ.) <input checked="" type="checkbox"/> 1 No. <input type="checkbox"/> 2Nos.			
	CONTACT TYPE	2 NO + 2 NC			
	RATING (AC / DC)	5A 240V AC AND 0.5A 220V DC			

	SPECIFICATION FOR MOTORISED VALVE ACTUATOR		SPECIFICATION NO.:	
			VOLUME	
			SECTION	
			REV. NO.	DATE:
			SHEET	3 OF 3
Data Sheet A & B				
DATA SHEET-A (TO BE FILLED BY PURCHASER)			DATA SHEET-B (TO BE FILLED-UP BY BIDDER)	
POSITION TRANSMITTER	POSITION TRANSMITTER (For inching duty & other specific applications)	<input checked="" type="checkbox"/> REQUIRED <input type="checkbox"/> NOT REQUIRED		
	MFR & MODEL NO.	BIDDER TO SPECIFY		
	TYPE	<input type="checkbox"/> ELECTRONIC (2 WIRE) R/I CONVERTER <input checked="" type="checkbox"/> ELECTRONIC (2 WIRE) CONTACTLESS		
	SUPPLY	<input checked="" type="checkbox"/> 24V DC <input type="checkbox"/>		
	OUTPUT	<input checked="" type="checkbox"/> 4-20mA		
	ACCURACY	± 1% FS		
SPACE HEATER	@SPACE HEATER	REQUIRED		
	@ POWER SUPPLY (NON INTEGRAL)	230V AC,1 PH.,50 Hz		
	@ POWER SUPPLY (INTEGRAL)	BIDDER TO SPECIFY		
	@ RATING	FOR MOTORS WITH RATING >30 KW		
TERMINAL BOX	ACTUATOR/MOTOR TERMINAL BOX	REQUIRED		
	ENCL CLASS ACTUATOR/MOTOR T.B.	@ <input type="checkbox"/> IP 68 @ <input type="checkbox"/>		
	@ EARTHING TERMINAL	8 SWG GI WIRE		
	PLUG & SOCKET(9 PIN) (FOR COMM, LS/TS FEED BACK, PoT)	<input type="checkbox"/> REQUIRED <input checked="" type="checkbox"/> NOT REQUIRED <input type="checkbox"/> <input type="checkbox"/> 2 NOS. <input type="checkbox"/>		
CABLE GLANDS	@ POWER CABLE GLAND	SIZE:DDE		
	@ SPACE HEATER CABLE GLAND	SIZE:DDE		
	OTHER CONTROL CABLE GLANDS-1	<input type="checkbox"/> 1No. for BFV of CW PUMP(Cable size 2Px1.5mm2)		
	OTHER CONTROL CABLE GLANDS-2	QUANTITY & SIZE: 1no., 2.5 sq. mm		
WEIGHT	TOTAL WEIGHT (ACTUATOR + ACCESSORIES)	BIDDER TO SPECIFY		_____ Kg.
NOTES: 1. SCOPE: DESIGN, MANUFACTURE, INSPECTION, TESTING AND DELIVERY TO SITE OF ELECTRIC ACTUATOR FOR INCHING OR OPEN / CLOSE DUTY. 2. CODES & STANDARDS: DESIGN AND MATERIALS USED SHALL COMPLY WITH THE RELEVANT LATEST NATIONAL AND INTERNATION STANDARD. AS A MINIMUM, THE FOLLOWING STANDARDS SHALL BE COMPLIED WITH: IS-9334, IS-2147, IS-2148, IS-325, IS-2959, IS-4691, IS 12615 AND IS-4722 3. TEMPERATURE RISE SHALL BE RESTRICTED TO 70 DEG. C FOR AMBIENT TEMPERATURE OF 50 DEG C. 4. CABLE GLANDS OF DOUBLE COMPRESSION TYPE, BRASS MATERIAL, WITH NICKEL COATING SHALL BE PROVIDED. 5. THE TORQUE SWITCHES SHALL BE PROVIDED WITH MECHANICAL LATCHING DEVICE TO PREVENT OPERATION WHEN UNSEATING FROM THE END POSITIONS. THE LATCHING DEVICE SHALL UNLATCH AS SOON AS THE VALVE LEAVES THE END POSITION. IF SUCH PROVISION IS NOT POSSIBLE, THE TORQUE SWITCHES SHALL BE BYPASSED BY END-POSITION LIMIT SWITCHES WHICH OPENS ON VALVE LEAVING END POSITION.THESE LIMIT SWITCHES ARE ADDITIONAL TO THE NUMBER OF LIMIT SWITCHES SPECIFIED ELSEWHERE. 6. THE MOTOR SHALL OPERATE SATISFACTORILY UNDER THE +/- 10% SUPPLY VOLTAGE VARIATION AT RATED FREQUENCY, -5% TO +3% VARIATION IN FREQUENCY AT RATED SUPPLY VOLTAGE, SIMULTANEOUS VARIATION IN VOLTAGE & FREQUENCY THE SUM OF ABSOLUTE PERCENTAGE NOT EXCEEDING 10%. 7. THE MOTOR SHALL BE SUITABLE FOR DIRECT ON LINE STARTING. \$\$ TORQUE SWITCH & LIMIT SWITCH SHALL ACT INDEPENDENT OF EACH OTHER. TANDEM OPERATION IS NOT ACCEPTABLE. ## EPOXY PAINT IS RECOMMENDED FOR COASTAL AREAS.				
NAME SIGNATURE DATE	PREPARED BY	CHECKED BY	APPROVED BY	VENDOR COMPANY SEAL
				NAME
				SIGNATURE
				DATE
NOTES* = TO BE FILLED BY MPL (LEAD AGENCY). @= TO BE FILLED BY ES				

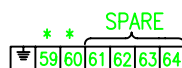
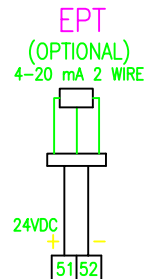
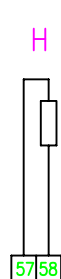
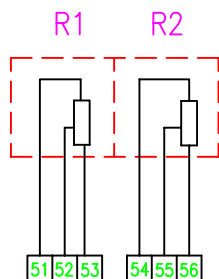
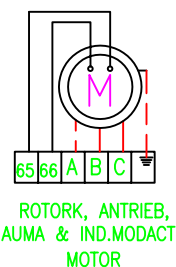
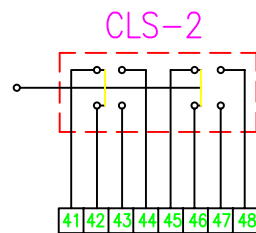
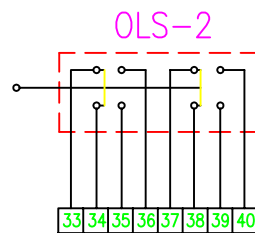
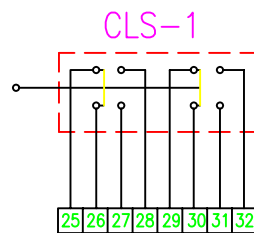
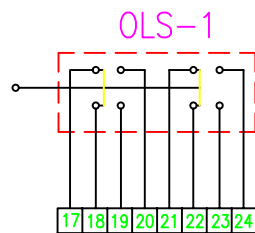
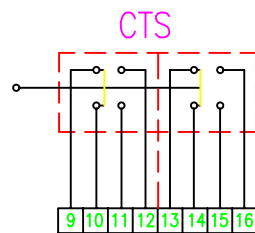
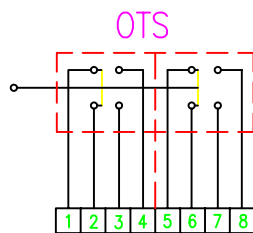
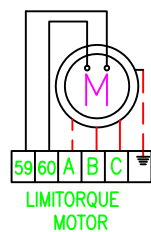

* - SPARE FOR ROTORK, AUMA, ANTRIEB & IND.MODACT

SWITCHES - ALL ARE POTENTIAL FREE AND TWO PAIR OF CONTACTS CAN BE USED FOR DIFFERENT SUPPLY
THERMOSTAT - 65-66 (ROTORK, AUMA, ANTRIEB & IND.MODACT), 59-60 (LIMITORQUE).

EPT - ELECTRONIC POSITION TRANSMITTER (POTENTIOMETRIC TYPE, FOR INCHING DUTY)

THERMOSTAT TERMINALS - TERMINATED IN MOTOR TB IN ANTRIEB & IND.MODACT AND IN MAIN TB IN OTHER MAKES

CTS - TORQUE SWITCHES FOR CW ROTATION (CLOSE) - 2 NO+2 NC

OTS - TORQUE SWITCHES FOR CCW ROTATION (OPEN) - 2 NO+2 NC

OLS-1, OLS-2 - LIMITSWITCHES FOR POSITION OPEN - 2 NO+2 NC

CLS-1, CLS-2 - LIMITSWITCHES FOR POSITION CLOSE - 2 NO+2 NC

OTS, CTS - TWO INDEPENDENT SWITCHES IN ANTRIEB & LIMITORQUE

OLS-2 & CLS-2 - CAM DISC IN ROTORK & ANTRIEB

R1-R2- POTENTIOMETER 2 x 100 OHMS

H - SPACE HEATER 1ϕ 240V AC SUPPLY

M - MOTOR 3ϕ 415V 50 Hz AC SUPPLY

SETTING PROCEDURE OF POSITION LIMIT AND TORQUE SWITCH				
VALVES	OPEN		CLOSE	
	MAIN	BACK UP	MAIN	BACK UP
GATE VALVE OF 100 mm AND ABOVE IN 1500 CL AND ABOVE RATINGS	OLS	OTS	CLS	CTS
ALL OTHER GATE & GLOBE VALVES	OLS	OTS	CTS	⊙

⊙ - CLS NOT TO BE CONNECTED IN TRIP CIRCUIT

NOTE:

1. BYPASS OTS FOR INITIAL 5% OF TRAVEL (FOR GATE VALVES ONLY)
2. CONNECT THERMOSTAT WITHOUT FAIL IN THE STARTER CIRCUIT

CONTACT DEVELOPMENT DIAGRAM

OTS	1-2	OFF AT OVER TORQUE DURING OPENING TRAVEL				
	3-4	ON AT OVER TORQUE DURING OPENING TRAVEL				
	5-6	OFF AT OVER TORQUE DURING OPENING TRAVEL				
CTS	7-8	ON AT OVER TORQUE DURING OPENING TRAVEL				
	9-10	OFF AT OVER TORQUE DURING CLOSING TRAVEL				
	11-12	ON AT OVER TORQUE DURING CLOSING TRAVEL				
OLS-1	13-14					
	15-16					
	17-18					
CLS-1	19-20					
	21-22					
	23-24					
OLS-2	25-26					
	27-28					
	29-30					
CLS-2	31-32					
	33-34					
	35-36					
SWITCH	37-38					
	39-40					
	41-42					
TERMINAL NO.	43-44					
	45-46					
	47-48					
		FULL OPEN	a	INTERMEDIATE	b	FULL CLOSE
VALVE POSITION						
— INDICATES CONTACT CLOSED						
- - - INDICATES CONTACT OPEN						

CONTACT RATING: 5A AT 250V AC & 0.5A AT 220V DC

						BHARAT HEAVY ELECTRICALS LTD. UNIT: HIGH PRESSURE BOILER PLANT. TIRUCHIRAPALLI 620014.	
				365-139			
		DRAWN		N.P.ESWAR		TITLE	
		CHECKED		K.ARUNACHALAM		INTERNAL WIRING DIAGRAM	
		APPROVED		P.LOGANATHAN		FOR	
		DATE		09.09.2000		ELECTRICAL VALVE ACTUATORS (AC)	
		CONTACT DEV. FIG.ADDED.				(DRAWN FOR INTERMEDIATE POSITION OF VALVES)	
11	09.09.2000						
REV	DATE	CHED	APPD	DESCRIPTION	DRAWING No.	4-V-MISC-90271	REV 11

RETRACED WITH REVISION 11



DATA SHEET FOR PRESSURE / DIFFERENTIAL PRESSURE TRANSMITTER

SPECIFICATION NO.:

VOLUME

SECTION

REV. NO.

DATE:

SHEET 1 OF 2

TAG No. Qty.....

Data Sheet No.: **PES-145-01-DS1-0**

Data Sheet A & B

DATA SHEET-A FOR PRESSURE / DIFFERENTIAL PRESSURE TRANSMITTER
(TO BE FILLED BY PURCHASER)

DATA SHEET-B
(TO BE FILLED-UP BY BIDDER)

GENERAL	MANUFACTURER	BIDDER TO SPECIFY		
	MODEL NUMBER	BIDDER TO SPECIFY		
TECHNICAL	TYPE	<input checked="" type="checkbox"/> CAPACITANCE/PIEZO ELECTRIC (Microprocessor based 2 wire type, HART protocol compatible)		
	POWER SUPPLY	24V DC		
	TRANSMITTER MEASUREMENT	<input type="checkbox"/> PRESSURE <input checked="" type="checkbox"/> DIFF. PRESSURE		
	OUTPUT SIGNAL	4-20 mA		
	NO. OF WIRE	TWO		
	ACCURACY	± 0.075% OF SPAN OR BETTER		
	LINEARITY, HYSTERISIS, DEAD BAND AND REPEATABILITY	± 0.1% OF SPAN		
	STABILITY	± 0.1% OF SPAN OR BETTER FOR 6 MONTHS FOR PRESSURE <70KG/CM2 ± 0.25% OF SPAN OR BETTER FOR 6 MONTHS FOR PRESSURE >70KG/CM2		
	SENSITIVITY	± 0.05% OF SPAN		
	<u>MATERIAL</u>			
	A) BODY	ALUMINIUM ALLOY OR BETTER		
	B) ELEMENT	316 SS		
	C) SEAL	TEFLON		
	CONTINUOUSLY ADJUSTABLE SPAN AND ZERO ADJUSTMENT PROVIDED	<input checked="" type="checkbox"/> YES <input type="checkbox"/> NO		
	MOUNTING	<input type="checkbox"/> WALL/PIPE STAND <input checked="" type="checkbox"/> TRANSMITTER RACK		
	ENCLOSURE	<input checked="" type="checkbox"/> NEMA-4X/IP 67 <input type="checkbox"/> NEMA-7		
	TURN DOWN RATIO	TO BE SPECIFIED BY BIDDER		
	INSULATION RESISTANCE	TO BE SPECIFIED BY BIDDER		
	ZERO SUPPRESSION RANGE	TO BE SPECIFIED BY BIDDER		
	ZERO ELEVATION RANGE	TO BE SPECIFIED BY BIDDER		
INTEGRAL INDICATOR	<input checked="" type="checkbox"/> YES <input type="checkbox"/> NO			

	DATA SHEET FOR PRESSURE / DIFFERENTIAL PRESSURE TRANSMITTER			SPECIFICATION NO.:	
				VOLUME	
				SECTION	
				REV. NO.	DATE:
TAG No. Qty.....			Data Sheet No.: PES-145-01-DS1-0		
Data Sheet A & B					
DATA SHEET-A FOR PRESSURE / DIFFERENTIAL PRESSURE TRANSMITTER (TO BE FILLED BY PURCHASER)				DATA SHEET-B (TO BE FILLED-UP BY BIDDER)	
	TRANSMITTER SHALL BE ABLE TO DRIVE OUTPUT IMPEDANCE OF 500 OHMS.	YES			
	ZERO DRIFT	± 0.11% PER DEG C			
	SPAN DRIFT	± 0.015% PER DEG C			
	<u>MANIFOLD</u>				
	DIFFERENTIAL PRESSURE MEASUREMENT	5 WAY			
	CABLE ENTRY DETAIL	SUITABLE FOR DIA OF 17.5 mm			
NAME SIGNATURE DATE	PREPARED BY	CHECKED BY	APPROVED BY	COMPANY SEAL NAME SIGNATURE DATE	



**DATA SHEET FOR PRESSURE /
DIFFERENTIAL PRESSURE TRANSMITTER**

SPECIFICATION NO.:	
VOLUME	
SECTION	
REV. NO.	DATE:
SHEET 1	OF 2

TAG No. Qty.....

Data Sheet No.: **PES-145-01-DS2-0**

Data Sheet C

DATA SHEET-C FOR PRESSURE / DIFFERENTIAL PRESSURE TRANSMITTER
(TO BE FILLED BY CONTRACTOR AFTER AWARD OF CONTRACT)

GENERAL	MANUFACTURER	
	MODEL NUMBER	
TECHNICAL	TYPE	
	POWER SUPPLY	
	TRANSMITTER MEASUREMENT	
	OUTPUT SIGNAL	
	NO. OF WIRE	
	ACCURACY	
	LINEARITY, HYSTERISIS, DEAD BAND AND REPEATABILITY	
	STABILITY	
	SENSITIVITY	
	<u>MATERIAL</u>	
	A) BODY	
	B) ELEMENT	
	C) SEAL	
	CONTINUOUSLY ADJUSTABLE SPAN AND ZERO ADJUSTMENT PROVIDED	
	MOUNTING	
	ENCLOSURE	
	TURN DOWN RATIO	
INSULATION RESISTANCE		
ZERO SUPPRESSION RANGE		
ZERO ELEVATION RANGE		
INTEGRAL INDICATOR		



DATA SHEET FOR PRESSURE / DIFFERENTIAL PRESSURE TRANSMITTER

SPECIFICATION NO.:	
VOLUME	
SECTION	
REV. NO.	DATE:
SHEET 2	OF 2

TAG No. Qty.....

Data Sheet No.: **PES-145-01-DS2-0**

Data Sheet C

DATA SHEET-C FOR PRESSURE / DIFFERENTIAL PRESSURE TRANSMITTER
(TO BE FILLED BY CONTRACTOR AFTER AWARD OF CONTRACT)

TRANSMITTER SHALL BE ABLE TO DRIVE OUTPUT IMPEDANCE OF 500 OHMS.	
ZERO DRIFT	
SPAN DRIFT	
<u>MANIFOLD</u>	
a) PRESSURE MEASUREMENT	
B) DIFFERENTIAL PRESSURE MEASUREMENT	
CABLE ENTRY DETAIL	

	PREPARED BY	CHECKED BY	APPROVED BY	COMPANY SEAL
NAME				NAME SIGNATURE DATE
SIGNATURE				
DATE				

9.2 Pressure / Differential Pressure / Flow / Level Transmitter
Table 9.1
Specifications for Pressure / Differential Pressure / Flow / Level Transmitter

S.N	Features	Minimum Requirements
1	Type	Microprocessor based 2 wire type, HART protocol compatible
2	Sensor Type	Capacitive/ Piezo-electric
3	Output Signal	4-20 mA signals superimposed with HART signal.
4	Signal Processing Unit	Microprocessor based
5	Overpressure	150% of max. operating pressure. For vacuum service, the element shall have under – range protection to full vacuum
6	Turn-down Ratio	10:1 for vacuum / very low pressure applications. 100:1 for other applications.
7	Stability	± 0.1% of calibrated span for six months up to 70 Kg/cm ² and ± 0.25% for range more than 70 Kg/cm ² (g).
8	Span and Zero drift	± 0.015% per deg. C at max span & 0.11% per deg. C at min. span.
9	Enclosure Class	Weather proof as per IP 67 with corrosion resistance coating. For hazardous area explosion proof enclosure as described in NEC article 500
10	Zero & span adjustability	Continuous, tamper proof, remote as well as manual from instrument with zero suppression and elevation facility.
11	Local Indicator	To be provided
12	Display	Digital LCD Integral Display (minimum 5 digit) Engineering Unit
13	Process connection	½" NPT (F)
14	Electrical connection	½" NPT
15	MOC of Electrical Housing	Aluminum Alloy or better
16	Ambient Temperature	65 Deg. C
17	Operating Voltage	16 – 48 Volts DC
18	Load	600 Ohms (minimum) at 24 Volts DC
19	Accuracy	± 0.075% of span or better
20	Response Time	100 milli-second or better
21	Adjustment/ calibration/ maintenance	Centralised PC based system maintenance per clause.

- All transmitters shall be equipped with all necessary accessories like valve manifolds, mounting bracket etc. Pulsation dampeners shall be used where the process media is unstable for measurement such as at the discharge of a pump. For absolute pressure transmitter, 2 valve manifold; for gauge / vacuum pressure transmitter, 3 valve manifold and



for DP / level / flow transmitter, 5 valve manifold shall be provided. In case if it becomes necessary to use a DP transmitter for pressure measurement then a 3 valve manifold shall be used in place of 2 valve manifold.

2. Pressure transmitter shall have easily accessible span, zero and time constant adjustments. A range suppression / elevation device shall be provided wherever required.
3. For pressure / differential pressure transmitter, proof pressure shall be 200% of maximum static process pressure.
4. All transmitter cases shall be dust – tight and rugged. Weather – proof and explosion – proof cases shall be used in outdoor and hazardous areas respectively. Protection clause shall be of IP 67 or better.
5. Transmitters for pressure / DP measurements of liquid and steam shall always be installed below the sampling point, preferably with the connection at the top.
6. Transmitters for pressure / DP measurements for gases and air shall always be installed above the sampling point, preferably with the connection at the bottom.
7. Transmitters with diaphragm seal system shall be considered when
 - The process temperature is outside of the normal operating ranges of the transmitter and cannot be brought into those limits with impulse piping or
 - The process is corrosive and would require frequent transmitter replacement or unusual materials of construction or
 - The process contains suspended solids or is viscous and may plug the impulse piping or
 - There is a need to make density or interface measurements or
 - The process medium may freeze or solidify in transmitter or impulse piping.
8. Diaphragm seal shall be either capillary type or direct mounted type depending upon the application. Parts below the diaphragm shall be removable for cleaning. The entire volume above the diaphragm shall be completely filled with an inert liquid suitable for the application.
9. Differential pressure type level transmitters shall be used for range above 1219 mm, for services requiring purge or where liquid might boil in external portions.
10. Differential pressure type level transmitters for use on corrosive service shall generally be diaphragm wafer with extended filled capillary type. Flush or extended diaphragm type DP transmitter shall be considered for special application. Diaphragm material shall normally be stainless steel or any other special alloy.



11. Differential pressure type flow transmitters shall have in-built square-root extractors.

9.3 **Temperature Transmitter**

Table 9.2
Specifications for Temperature Transmitter

S.N	Features	Minimum Requirements
1	Type	2-Wire, Smart (HART)
2	Output Signal	4-20 mA signals superimposed with HART signal.
3	Signal Processing Unit	Microprocessor based
4	Accuracy	± 0.075 % of span or better
5	Local Indicator	To be provided
6	Display	Digital LCD Integral Display (minimum 5 digit) Engineering Unit
7	Input	Ohm input from Pt-100 RTD/ mV signal from thermocouples
8	Stability	± 0.1 % of reading or 0.1°C, whichever is greater, for 24 months for RTDs. ± 0.1 % of reading or 0.1 °C, whichever is greater, for 12 months for thermocouples
9	Output	4-20 mA DC, linear
10	Load	600 Ohms (minimum) at 24 Volts DC
11	Power Supply	24 VDC, 2- Wire Loop Power
12	MOC of Electrical Housing	Aluminum Alloy or better
13	Enclosure Class	Weather proof as per IP 67 with corrosion resistance coating. For hazardous area explosion proof enclosure as described in NEC article 500

1. The temperature transmitter of following types (2-wire Loop Powered temperature transmitter) compatible with thermocouples and RTDs shall be provided. Cold junction temperature compensation of the thermocouples shall be performed in the temperature transmitter itself.

a. Single Input DIN-rail mounted Temperature Transmitter

These shall be suitable for mounting on DIN-rails in Panels/JBs in air conditioned room. This temperature transmitter shall be the ones which are especially designed for DIN-rail mounting with IP 20 protection class. These shall have terminals for input/output provided on front side when mounted on DIN-rail. Head mounted temperature transmitter with clamps to make it suitable for DIN-rail mounting shall not be acceptable under this category.

	CHECK LIST FOR PRESSURE / DIFFERENTIAL PRESSURE TRANSMITTER (Mechanical Auxiliary Packages)	SPECIFICATION NO.:	
		VOLUME	
		SECTION	
		REV. NO.	DATE:
		SHEET 1 OF 1	
Data Sheet No.: PE-CL-999-145-1026-0			

SL NO	TESTS/CHECKS	QUANTM OF CHECK	REFERENCE DOC. ACCEPTANCE NORMS	AGENCY			REMARKS
				M	C	B	
1.0	CHECKS FOR VISULA, MODEL TAG NO.	SEE NOTE-1 BELOW	APPROVED TECHINCAL REQUIREMENT/ DATA SHEET	P	W	V	MFR TO CARRY OUT ROUTINE TEST ON 100%. WHEN MATERIAL CORELATION ARE NOT AVAILABLE MFR'S COMPLIANCE TO BE PROVIDED
2.0	PROCESS CONNECTION	-do-		P	W	V	
3.0	ACCURACY	-do-		P	W	V	
4.0	REPEATEABILITY	-do-		P	W	V	
5.0	HYSTERISIS	-do-		P	W	V	
6.0	EFFECT OF TEMP VARIATION ON ACCURACY	-do-		P	W	V	
7.0	SPAN /ZERO ADJUSTMENT	ONE/TYPE		P	W	V	
8.0	EFFECT OF SUPPLY VOLTAGE VARIATION	ONE/TYPE		P	W	V	
9.0	HIGH PRESSURE TEST	SEE NOTE-1 BELOW		P	W	V	
10.0	BURN IN TEST	ONE/TYPE		P	W	V	
11.0	DEGREE OF PROTECTION	ONE/TYPE		P	W	V	

LEGEND:

M: MANUFACTURER/ SUB CONTRACTOR, C: CONTRACTOR/ NOMINATED INSP AGENCY, B: BHEL. P: PERFORM, W: WITNESS, V: VERIFICATION.

NOTE:

- QUANTUM OF CHECK SHALL BE AS BELOW
100 % - BY MANUFACTURER
RANDOM FOR EACH TYPE – BY BHEL & CUSTOMER
- MANUFACTURER TO MAINTAIN CALIBRATED INSTRUMENT HAVING BETTER ACCURACY THAN THE ITEM UNDER TEST. INSPECTING ENGINEER SHALL CHECK THE SAME.
- IN CASE OF IMPORTED ITEMS CONTRACTORS SHALL REVIEW TC's AND NOT INSPECT.

CONTRACTOR TO PROVIDE COMPLIANCE CERTIFICATE FOR TESTS/CHECKS VERIFIED BY CONTRACTOR AND SUBMIT THE SAME ALONGWITH TEST CERTIFICATES TO BE VERIFIED BY BHEL.



**DATA SHEET FOR
PRESSURE / DIFFERENTIAL PRESSURE GAUGE**

SPECIFICATION NO.:	
VOLUME	
SECTION	
REV. NO.	DATE:
SHEET 1	OF 1

TAG No. Qty.....

Data Sheet No.: **PE-DC-999-145-I026**

Data Sheet A & B

DATA SHEET-A FOR PRESSURE / DIFFERENTIAL PRESSURE GAUGE
(TO BE FILLED BY PURCHASER)

DATA SHEET-B
(TO BE FILLED-UP BY BIDDER)

GENERAL	MANUFACTURER		
	MODEL NUMBER		
TECHNICAL	PRESSURE ELEMENT	<input checked="" type="checkbox"/> BOURDON <input type="checkbox"/> DIAPHRAGM <input type="checkbox"/> BELLOW	
	MATERIAL	SENSING ELEMENT – AISI 316 SS MOVEMENT – AISI 304 SS CASING – <input type="checkbox"/> DIE CAST AL <input checked="" type="checkbox"/> SS	
	ENCLOSURE	<input type="checkbox"/> INDOOR MOUNTED IP-55 <input checked="" type="checkbox"/> OUTDOOR MOUNTED IP-65 <input type="checkbox"/> FUEL GAS HAZARDOUS APPL. EXPL. PROOF	
	DIAL	SIZE: <input type="checkbox"/> 100MM <input checked="" type="checkbox"/> 150MM COLOR: WHITE NUMERALS: BLACK SCALE: <input checked="" type="checkbox"/> LINEAR <input type="checkbox"/> SQUARE ROOT	
	CASE	COLOUR : BLACK	
	ADJUSTMENT	<input checked="" type="checkbox"/> EXT. MICROMETER SCREW <input type="checkbox"/> INT. MICRO SCREW	
	MOUNTING	<input checked="" type="checkbox"/> LOCAL <input type="checkbox"/> PANEL OR RACK	
	OVER RANGE PROTECTION	150% OF FSD	
	BLOW OUT DISC	SUITABLE MATERIAL	
	SWITCHING FACILITY TYPE NO. / TYPE OF CONTACTS CONTACT RATING SETTING RANGE REPEATABILITY POWER SUPPLY	<input type="checkbox"/> YES <input checked="" type="checkbox"/> NO <input type="checkbox"/> MICRO SWITCH <input type="checkbox"/> OTHER 2 NOS. SPDT 5A 230V AC, 0.25A 220V DC FIELD ADJUSTABLE OVER FULL RANGE $\pm 1\%$ OF FSR 230V AC (if required)	
PERFORMANCE	ACCURACY	$\pm 1\%$ OR BETTER OF FULL SCALE DEFLECTION	
CONNECTION	PROCESS	1/2 " NPT(M)	
	LOCATION	<input type="checkbox"/> BACK <input checked="" type="checkbox"/> BOTTOM	
ACCESSORIES	NAME PLATE / METAL TAG	SS	
	MOUNTING	<input type="checkbox"/> WALL <input checked="" type="checkbox"/> PIPE – U CLAMPS & BOLTS <input type="checkbox"/> PANEL / RACK	
	OTHER	AS PER ENCLOSED DIAGRAM OR CUSTOMER SPECIFICATION	
NAME			NAME
SIGNATURE			SIGNATURE
DATE			DATE



**DATA SHEET FOR
PRESSURE / DIFFERENTIAL PRESSURE GAUGE**

SPECIFICATION NO.:	
VOLUME	
SECTION	
REV. NO.	DATE:
SHEET 1	OF 1

TAG No. Qty.....

Data Sheet No.: **PE-DC-999-145-1026**

Data Sheet C

DATA SHEET-C FOR PRESSURE / DIFFERENTIAL PRESSURE GAUGE
(TO BE FILLED BY CONTRACTOR AFTER AWARD OF CONTRACT)

GENERAL	MANUFACTURER		
	MODEL NUMBER		
TECHNICAL	PRESSURE ELEMENT		
	MATERIAL		
	ENCLOSURE		
	DIAL		
	CASE		
	ADJUSTMENT		
	MOUNTING		
	OVER RANGE PROTECTION		
	BLOW OUT DISC		
	SWITCHING FACILITY TYPE NO. / TYPE OF CONTACTS CONTACT RATING SETTING RANGE REPEATABILITY POWER SUPPLY		
PERFORMANCE	ACCURACY		
CONNECTION	PROCESS		
	LOCATION		
ACCESSORIES	NAME PLATE / METAL TAG		
	MOUNTING		
	OTHER		
NAME			NAME
SIGNATURE			SIGNATURE
DATE			DATE



2. Thermo wells shall, in general, be of SS 316 and shall be drilled from bar stock except for air and flue gas services. However, selection of thermo well material shall be as per following guideline.
3. Welded type thermo wells with 38 mm O.D. for welding & ½" NPT internal threads shall be used for pressure above 100 kg / sq cm or temperature above 400 deg C. Socket weld type thermo well with 34 mm O.D. for welding & ½" NPT internal thread, shall be used for pressure between 40-100 kg/cm² and temperature up to 400°C. Screwed type thermo wells with ½" NPT internal threads & M33X2 (M) outer threads shall be used for pressure below 40 kg/cm² and temperature below 400°C. For pipes having probability of prolonged vibration, seal welding may be done all around after tightening the thermo well within the base.
4. Thermo well manufacturing drawing covering material specification, dimensional details, details of special treatment, finish etc. as well as test procedure shall be subject to Owner's / Consultant's approval. Material certificate shall have to be furnished for each thermo well.
5. Wherever any approval is necessary from any recognized body / authority during manufacturing of high pressure wells, the same shall have to be arranged by the Contractor.
6. The thermo well immersion depth (U) shall be sufficient to eliminate conduction error. A general rule which may be followed is to use an immersion length equalling a minimum of 10 times the diameter of the protective tube or well. In general, immersion length of thermo wells for different line sizes shall be as follows:

Table 9.5

Thermowell Immersion Length

S.N	Line Size	Immersion Length
1	From 4" to 6"	65 mm
2	From 8" & onwards	140 mm
3	Vessels	400 mm

9.7 Pressure Gauge/ Differential Pressure Gauge/Draft Gauge

Table 9.6

Specification for Pressure Gauge/ DP Gauge/ Draft Gauge

S.N	Feature	Minimum Requirement
1	Type	Bourdon / Bellows / Diaphragm
2	Sensing Element Material	AISI 316 SS
3	Movement Material	AISI 304 SS



S.N	Feature	Minimum Requirement
4	Case Material / Protection Class	SS / IP 65
5	Dial Size	150 mm For Special application 250 mm shall be used
6	Scale	Black lettering on white background in 270 °C arc
7	Range Selection	Normally operate at 75% of its maximum pressure range. Instruments measuring varying pressures shall operate in a band of 60% of its maximum pressure range.
8	Over range Protection	150% of maximum range by internal stop. External stop below zero.
9	Adjustment	External Micrometer screw for zero adjustment. Internal micrometer screw for range adjustment.
10	Stop at Max. Reading	Shall be provided
11	Element Connection	Argon welding
12	Process Connection	½" NPT(M) bottom connection for local mounting, back connection for panel mounting
13	Accuracy	+/- 1.0 % of full scale or better
14	Operating Ambient Temperature	50 °C (Max. continuous)
15	Safety Feature	Neoprene Safety Diaphragm (Blowout disc) at the back
16	Window	Shatter-proof glass
17	Chemical Seal Unit	SS 316 Flange and Diaphragm, PTFE coated / block, Silicon Oil filling fluid
18	Accessories	Snubbers for pulsating fluid applications / 3-way gauge cock / 2-valve manifold / Pigtail / Siphon for steam service / Gauge Saver, if maximum or Design Pressure is very high than the Operating Pressure / Counter Flanges / Bolts, Nuts, Gaskets / SS Tag Plate

1. Directly connected pressure measuring instruments shall be diaphragm, bourdon or bellow type elements depending upon the services conditions. In general, diaphragm elements shall be used in the range of 0 to 1000 mm water column pressure, bellow type element for ranges of 0 to 1 Kg/cm² and bourdon type element for ranges greater than 1 Kg/cm².
2. Primary element material shall be corrosion resistant to process fluid or diaphragm seals shall be provided for protection.
3. For draft measurement Teflon coated beryllium copper diaphragm shall be used.



4. Snubbers shall be floating pin type, externally mounted and externally adjustable. It shall be used for all pulsating services.
5. Diaphragm seals, filled type or mechanical type shall be furnished where plugging of the element may occur or where suitable material is not available in highly corrosive services. When chemical seals are required, they shall be the clean out type with flushing connection.
6. Over-range protection shall be provided to at least 150 % of range. For vacuum service, the element shall have under-range protection to full vacuum
7. Ranges of the gauges shall be so selected that the gauge normally operates in the middle third of the scale and conform to IS 3624 standard dials, wherever necessary.
8. The sensing elements for all gauges shall be properly aged and factory tested to remove all residual stresses and shall be SS 316 with forged socket and tip of the same material. Elements above 70 Kg/sq. cm range shall be bored instead of drawn.
9. For low pressure application where long elements are used, well supported protecting tube shall be installed to prevent mechanical damage and erosion of the elements.

9.8 Temperature Gauge

**Table 9.7
Specification for Temperature Gauge**

S.N	Feature	Minimum Requirement
1	Type	Mercury filled
2	Sensing Element material	Bourdon AISI 316 SS
3	Movement Materials	AISI 304 SS
4	Case Material/Protection class	SS / IP65
5	Capillary Armouring	SS Flexible
6	Capillary	SS 316 (5 mtr. Length for Local & 15 metre for panel Mounting)
7	Bulb/Stem Diameter	12 mm
8	Dial Size	150 mm
9	Window	Shatterproof glass
10	Scale	Black lettering on white background in 270 °C arc
11	Adjustment	Micrometer screw for zero adjustment. Internal micrometer screw for range adjustment.
12	Pointer	Externally Adjustable
13	Range Selection	Normal Process Temperature –