

2X500 MW NNTPS NEW NEYVELI

TECHNICAL SPECIFICATION FOR SELF CLEANING STRAINERS (SCS)

Specification No. : PE-TS- 402-165-N003 (REV. 0)

VOLUME -IIB

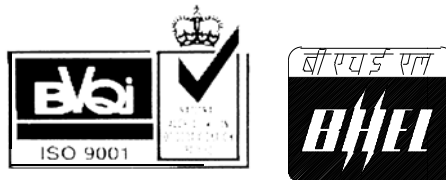

**BHARAT HEAVY ELECTRICALS LIMITED
POWER SECTOR
PROJECT ENGINEERING MANAGEMENT
PPEI BLDG., SEC-16A, PLOT NO. 25
NOIDA – 201301 (UP)**

	TITLE : TECHNICAL SPECIFICATION FOR SELF CLEANING STRAINERS (SCS)	SPEC. NO. PE-TS- 402-165-N003
	PREAMBLE	VOLUME : II B
		REV. NO. 0 DATE :30.05.2014
		SHEET 1 OF 2

1.0 The tender document contains three (3) volumes. The bidder shall meet the requirements of all the three volumes.

1.1 **Volume -I CONDITIONS OF CONTRACT**

This consists of four parts as below :

Volume - I A : This part contains instructions to bidders for making bids to BHEL.

Volume - I B : This part contains general commercial conditions of the tender and include provision that vendor shall be responsible for the quality of item supplied by their sub-vendors.

Volume - I C : This part contains special conditions of contract.

Volume - I D : This part contains commercial conditions for erection and commissioning site work, as applicable.

1.2 **Volume - II TECHNICAL SPECIFICATIONS**

Technical requirements are stipulated in Volume II which comprises of :

Volume - II A : General Technical Conditions

Volume - II B : Technical specification including drawings, if any

1.2.1 **Volume - II B :**

This volume is sub-divided into following sections:

Section - A : This section outlines the scope of enquiry.

Section - B : This section provides "Project Information"

Section - C : This section indicates technical requirements specific to the contract, not covered in Section-D.

Section - D : This section comprises of standard technical specifications of equipments complete with data sheet A, B & C.

Data sheet-A specifies data and other requirements pertaining to the equipment.

Data sheet - B specifies data to be filled by the bidder (Data Sheet B is contained in Volume - III)

Data sheet - C indicates data documents to be furnished after the award of contract as per agreed schedule by the vendor (as applicable).



TITLE : TECHNICAL SPECIFICATION
FOR
SELF CLEANING STRAINERS (SCS)

PREAMBLE

SPEC. NO. PE-TS- 402-165-N003

VOLUME : II B

REV. NO. 0 | DATE :30.05.2014

SHEET 2 OF 2

1.2.2 **Volume - III TECHNICAL SCHEDULES**

- 1.0 This volume contains technical schedules and Data Sheets - B, which are to be duly filled by the bidder and the same shall be furnished with the technical bid as per instructions given in Document No.PES-100-901 in Volume-III.
- 2.0 The requirements mentioned in Section C/Data Sheets-A of Section-D shall prevail and govern in case of conflict between the same and the corresponding requirements mentioned in the descriptive portion in Section -D.



**TITLE : TECHNICAL SPECIFICATION
FOR
SELF CLEANING STRAINERS (SCS)**

SPEC. NO. PE-TS-402-165-N003

VOLUME : II B

SECTION : A

REV. NO. 0

DATE :30.05.2014

SHEET 1 of 1

INDEX

SECTION	TITLE
A	SCOPE OF ENQUIRY
B	PROJECT INFORMATION
C	SPECIFIC REQUIREMENTS
C1	SPECIFIC TECHNICAL REQUIREMENTS FOR SELF CLEANING STRAINERS.
C2	SPECIFIC TECHNICAL REQUIREMENTS (ELECTRICAL)
C3	SPECIFIC TECHNICAL REQUIREMENTS (C&I)
D	STANDARD TECH. SPECIFICATIONS
D1	SELF CLEANING STRAINER <ul style="list-style-type: none">◆ STANDARD TECHNICAL SPEC.NO. PE-TS-999-165-N002◆ DATA SHEET-A◆ DATA SHEET-C◆ QUALITY PLAN
D2	ELECTRICAL SYSTEMS
D3	CONTROL & INSTRUMENTATION SYSTEMS



TITLE : TECHNICAL SPECIFICATION
FOR
SELF CLEANING STRAINERS (SCS)

SPEC. NO. PE-TS-402-165-N003

VOLUME : II B

SECTION : A

REV. NO. 0

DATE :30.05.2014

SHEET

1

of

1

SECTION - A
SCOPE OF ENQUIRY



TITLE : TECHNICAL SPECIFICATION
FOR
SELF CLEANING STRAINERS (SCS)

SPEC. NO. PE-TS-402-165-N003

VOLUME : II B

SECTION : A

REV. NO. 0

DATE :30.05.2014

SHEET

1

of

2

1.00.0 SCOPE

This enquiry covers the design, manufacture, assembly, inspection and testing at manufacturer's and/or his sub-contractors works properly packed for delivery of the items as follows:

1.01.0 Self Cleaning Strainers :

Self Cleaning Strainers (SCS) complete with all accessories as per the requirements specified in different sections of this specification for 2X500 MW NNTPS NEW NEYVELLI.

The bidder's scope also includes installation checks, commissioning, trial runs & PG Testing at site of SCS.

1.01.1 The bids shall be evaluated as per NIT.

2.00.00 GENERAL TECHNICAL INSTRUCTIONS:

2.01.00 It is not the intent to specify herein all the details of design and manufacture. However the equipment shall conform in all respects to high standard of design, engineering and workmanship, and shall be capable of performing the required duties in a manner acceptable to Engineer/ Owner, who will interpret the meaning of drawing and specifications, and shall be entitled to reject any component or material, which in his judgement is not in full accordance herewith.

2.0.2.00 The omission of specific reference to any component/ accessory necessary for the proper performance of the equipments shall not relieve the bidder of the responsibility of providing such facilities to complete the supply of the equipments at quoted prices.

2.03.00 In case of any deviation from this Technical specification (Vol. IIB) and General Technical Conditions (Vol. IIC), the same shall be indicated in the schedule of deviations enclosed in Volume-III, Part-A. In the absence of duly filled schedules it will be assumed that the bid strictly conforms to the specification.

2.04.00 BHEL's/ Customer's representatives shall be given full access to the shop in which the equipments are being manufactured or tested and all test records shall be made available to him.

2.05.00 The equipments covered under this specification shall not be despatched unless the same have been finally inspected, accepted and shipping release issued by BHEL/ Customer

2.06.00 Un-priced copy of price bid shall be furnished alongwith the technical bid.



**TITLE : TECHNICAL SPECIFICATION
FOR
SELF CLEANING STRAINERS (SCS)**

SPEC. NO. PE-TS-402-165-N003

VOLUME : II B

SECTION : C

REV. NO. 0

DATE :30.05.2014

SHEET

1

of

1

SECTION - B

PROJECT INFORMATION



SECTION - 2

2 GENERAL PROJECT INFORMATION

2.1 Introduction

The project site at Neyveli has distinct location advantages, being at pit-head distance from the source of lignite supply from Mines, making it convenient for transportation of lignite by belt conveyor. Water source is readily available from the nearby mines lake. Besides, other infrastructure such as access road, railway connection etc, already exist.

2.2 Power Plant Site

The power plant site is located at Neyveli, opposite to the now defunct Fertilizer and Briquetting & Carbonization Plant, near TPS-1 Expansion and TPS-II.

2.3 Project & Site Information

- | | | | |
|---------|---------------------------------|---|--|
| (i). | Owner/Purchaser | : | Neyveli Lignite Corporation Limited (NLC Ltd), Neyveli, Cuddalore District, Tamil Nadu State, India |
| (ii). | Consultant | : | Lahmeyer International (India) Pvt. Ltd (LII), Gurgaon, NCR, India. |
| (iii). | Project Title | : | 2x500 MW Neyveli New Thermal Power Station (NNTPS) |
| (iv). | Location | : | 200 kms south of Chennai and 50 kms south-west of Cuddalore |
| (v). | Latitude | : | 11° 34' 00" N to 11° 35' 00" N |
| (vi). | Longitude | : | 79° 26' 00" E to 79° 27' 00" E |
| (vii). | Elevation above MSL | : | + 67 m |
| (viii). | Nearest Railway Station | : | Neyveli, |
| (ix). | Nearest Sea Port | : | Chennai, at a distance of 200 km |
| (x). | Nearest Airport | : | Chennai, at a distance of 200 km |
| (xi). | Road Access/Approach to Site | : | Connected by Chennai-Thanjavur NH 45C road and state highway connecting Cuddalore – Virudhachalam via Neyveli. Both NH and state high way roads are well connected to NLC township roads. The approach road is approximately 15 kms from Chennai–Thanjavur NH – 45C road |
| (xii). | Site Meteorological Data | | |
| | • Max ambient temperature | : | 42.8° C |

Document Number	Rev No.	Description	Page No.	Date of Issue
LII-GEOE11019-G-00156-002	02	TG, Vol-IA, IFB-NTA2	- 9-	25-Jun-11



- Min Ambient Temperature : 26.9° C
 - Wet bulb temp : 29° C
 - Max. Relative Humidity : 92 % in the month of September
 - Min. Relative Humidity : 23 % in the month of May
 - Rainfall : About 1265.7 mm annually (average)
 - Wind direction : South West to North East direction
 - Wind Speed : 97.2 km/hr (maximum recorded)
4.3 km/hr (average wind speed)
 - Seismicity : As per IS: 1893 (part 4) (Zone-II)
Importance factor: 1.75.
- (xiii). Languages spoken in the region : English, Tamil

* * * * *

Document Number	Rev No.	Description	Page No.	Date of Issue
LII-GEOE11019-G-00156-002	02	TG, Vol-IA, IFB-NTA2	- 10-	25-Jun-11



**ATTACHMENT - 1
RAW WATER ANALYSIS**

The typical raw water analysis is as shown below:

S.No	Description	Unit	Normal Values
1	Source		Lake water
2	Temperature	°C	30
3	Colour	-	Colourless
4	Odour	-	Odourless
5	Oil	mg/l	Nil
6	Grease	mg/l	Nil
7	Total solids in ppm	mg/l	519
8	Calcium hardness as CaCO ₃	mg/l	120
9	Magnesium hardness as CaCO ₃	mg/l	78
10	Sodium + Potassium as CaCO ₃	mg/l	95.35
11	Chloride as CaCO ₃	mg/l	84.6
12	Sulphate as CaCO ₃	mg/l	84.7
13	M alkalinity as CaCO ₃	mg/l	160
14	P alkalinity as CaCO ₃	mg/l	Nil
15	Iron as CaCO ₃	mg/l	1.25
16	Silica as SiO ₂	mg/l	36.4
17	Aluminium as CaCO ₃	mg/l	34.7
18	Conductivity at 30 °C	m-	590
19	pH at 30 °C	-	7.0
20	Free CO ₂	-	19.36
21	Total hardness (as CaCO ₃)	mg/l	198

Document Number	Rev No.	Description	Page No.	Date of Issue
LII-GEOE11019-G-10055-002	02	NTA2- Vol – IIA, Attach – 1	1	25-Jun-11



**TITLE : TECHNICAL SPECIFICATION
FOR
SELF CLEANING STRAINERS (SCS)**

SPEC. NO. PE-TS-402-165-N003

VOLUME : II B

SECTION : C

REV. NO. 0

DATE :30.05.2014

SHEET

1

of

1

SECTION – C

SPECIFIC REQUIREMENTS

SECTION C1 : SELF CLEANING STRAINERS

SECTION C2 : ELECTRICAL SYSTEMS

SECTION C3 : C&I SYSTEMS



**TITLE : TECHNICAL SPECIFICATION
FOR
SELF CLEANING STRAINERS (SCS)**

SPEC. NO. PE-TS-402-165-N003

VOLUME : IIB

SECTION : D

REV. NO. 0

DATE :30.05.2014

SHEET 1of 1

**SECTION C1
SELF CLEANING STRAINERS
(MECHANICAL DETAILS)**



TITLE : TECHNICAL SPECIFICATION
FOR

SELF CLEANING STRAINERS(SCS).

SPEC. NO: PE-TS-402-165-N003

VOLUME : II B

SECTION:C1

REV. NO. 0

DATE :11.09.2014

SHEET 1 OF 8

1.0 GENERAL

The Self Cleaning Strainers (SCS) complete with all accessories shall conform to the standard technical specifications (Section-D) and Data Sheet-A enclosed herewith. In addition the requirements of this section C shall also be complied with. However, wherever the details given in Section-D and Data Sheet-A are different, the requirements of Data Sheet-A shall prevail. Similarly in the event of contradictions between Section-C & Section-D/ Data Sheet-A, Section-C shall prevail.

Section C consists of 3 parts viz. Sec. C1, C2 and C3 for Mechanical, Electrical and C&I respectively, the requirements of all 3 sections shall be complied with.

2.0 DESCRIPTION OF EQUIPMENTS :

2.1 Self Cleaning Strainers (SCS) :

Self Cleaning Strainers per unit where specified shall be installed on the suction side of ACW booster pumps. The water through the self cleaning strainers outlet shall be supplied to the Secondary side of Plate Heat Exchangers. The water analysis is indicated in project information in section B.

3.0 SCOPE OF SUPPLY UNDER THE SPECIFICATION IN THE BIDDER'S SCOPE FOR SELF CLEANING STRAINERS.

3.1 The scope of supply for Self Cleaning Strainers covered under this specification is as under.

The size, MOC's and other particulars of the equipments are detailed in Data Sheet A annexed with Section – D of the specification.

SL.NO.	PROJECT	SELF CLEANING STRAINERS
1.	2X500 MW NNTPS NEW NEYVELLI	3 SETS PER UNIT VIZ. TOTAL 6 SETS FOR 2 UNIT.



TITLE : TECHNICAL SPECIFICATION
FOR

SELF CLEANING STRAINERS(SCS).

SPEC. NO: PE-TS-402-165-N003

VOLUME : II B

SECTION:C1

REV. NO. 0

DATE :11.09.2014

SHEET 2 OF 8

3.2 SCOPE OF SUPPLY OF SCS INCLUDED IN THE BIDDER'S SCOPE :

The Qty of SCS covered under the specification shall be as per Data Sheet A of respective projects.

Each self cleaning strainer shall be complete with following accessories and auxiliaries.

- a) Flushing pump with drive Motor (as per manufacturer's design) - 1 No.
- b) Supply of complete debris disposal pipe work shall be in scope of Bidder. However, bidder is to consider debris disposal pipework and bends as per the list of BOQ mentioned in Annexure-I to this Section. In case actual, still bidder has to supply the same as minimum requirement. Bidder shall finalize the pipework to suit the layout at contract stage in such a way that no site welding is required for his pipework otherwise the same shall be carried out by bidder at site.
- c) All Valves and NRVs in Bidder's Inter Connecting Piping/Debris Disposal Piping along with their Counter Flanges. (Refer Annexure-II of this Section)
- d) Filter body/ housing Vent and Drain connections along with their isolating valves.
- e) SCS shall be supplied along with flanges as well as the Counter flanges, complete with bolts, nuts and gaskets.
- f) Differential pressure measuring system for SCS. DP measuring system shall comprise of 2 Nos. DPT + 1 No. DPG for SCS and shall be with *Remote seal* arrangement . Stubs for DPT and DPG shall be independent.
- g) Supporting arrangement complete with foundation plates, anchor bolts, nuts, sleeves, inserts, all installation materials, fixing bolts, clamps, saddle supports (if applicable) and other accessories etc for complete equipment supplied under this package.
- h) Set of commissioning spares, on "As required basis".
- i) The Electrical & C&I items/ accessories as specified in succeeding clause / respective sections herein.

a) Local Control Panel shall be as follows:

3 Sets of SCS for each unit shall have one Common Local Control Panel Cum PLC Control System.

Local Control Panel should have suitable arrangement like Bus Coupler for



TITLE : TECHNICAL SPECIFICATION
FOR

SELF CLEANING STRAINERS(SCS).

SPEC. NO: PE-TS-402-165-N003

VOLUME : II B

SECTION:C1

REV. NO. 0

DATE :11.09.2014

SHEET 3 OF 8

providing redundancy to incoming supply feeder (1Working + 1 Standby feeder).

- j) Power and Control cables between Local Control Panel, PLC and various drives in bidder's scope of supply.
- k) Control cables between field instruments and Local Control panel.
- l) Control Cables along with connecting accessories from PLC to DCS as mentioned in Section C3.
- m) Laptop as per C&I Requirement mentioned in Section C3.
- n) Set of mandatory spares as indicated in Data Sheet A.
- o) All the field instruments stipulated in this specification shall be in Bidder's scope.
- p) Finish paints for touch up painting of equipment after erection at site, in sealed containers.
- q) Set of special tools and tackles if required for maintenance and erection of the equipment supplied.
- r) Various drawings, data test reports/ certificates instruction manuals for erection operation and maintenance etc. as specified in Data Sheet-C. and cables schedule indicating BOQ for power & control cables.
- s) Local Control Panels & Instruments: Scope and Type as specified in C&I section wherever required.

Any item not specified but required to make SCS a complete package shall also be in bidders scope.

4.0 SCOPE OF SERVICES INCLUDED IN THE BIDDER'S SCOPE :

The bidder's scope also includes following services at site, for scope under this specification for SCS for respective projects

- a) Installation checks (Erection in BHEL's scope).
- b) Commissioning of equipment.
- c) Trial run for requisite period
- d) Performance Testing

The trial run of equipment shall be generally conducted immediately after commissioning while PG testing shall be conducted at a later date. These activities for different units shall be timed separately.



TITLE : TECHNICAL SPECIFICATION
FOR
SELF CLEANING STRAINERS(SCS).

SPEC. NO: PE-TS-402-165-N003

VOLUME : II B

SECTION:C1

REV. NO. 0

DATE :11.09.2014

SHEET 4 OF 8

The no. of visits may be suitably assessed by bidders as per their experience with site stay periods on as required basis.

In the event of order no. of visits as follows shall be made as a minimum with charges included in the bidder's base price itself.

- **For drawings/documents approval**

In the event of order all drawings / documents in soft as well as hard copy shall be submitted as per NIT.

Further on receipt of Customer comments, if required bidder's engineer shall visit BHEL/ Customer alongwith soft copy to resolve all issues and incorporate comments in the soft copy for across the table finalisation and Category-I approval.

- **Site Visits :**

- No. of site visits for combined activities of erection checks and commissioning for SCS as applicable shall be one per unit - for both sets of equipments of one unit. Time duration for erection and commissioning shall be "on as required basis" with equipments run for trial operation thereafter for requisite period to demonstrate satisfactory operation.

However the no. of visits may be suitably assessed by bidders as per their experience with site stay periods on as required basis.

- Bidder shall demonstrate guarantees including pressure drops at site during subsequent visit for SCS of each unit.
- For trouble shooting on "as required basis".

5.0 EXCLUSIONS :

The following are excluded from the bidder's scope .

- 5.1 Civil foundation works required for installation
- 5.2 Erection of Equipment at site.

6.0 DESIGN CONSTRUCTION :

In addition to the requirements of Section-D the following shall also be complied with for packages/ projects under scope of this specification:



TITLE : TECHNICAL SPECIFICATION
FOR

SELF CLEANING STRAINERS(SCS).

SPEC. NO: PE-TS-402-165-N003

VOLUME : II B

SECTION:C1

REV. NO. 0

DATE :11.09.2014

SHEET 5 OF 8

- 6.1 The materials of construction specified in Data Sheet-A are minimum requirements and materials of construction for other components not specified shall be similarly selected by the bidder for the intended duty which shall be subject to purchaser's approval during detailed engineering in the event of order.
- 6.2 Housing/ body of SCS Filter shall be designed and manufactured as per the applicable codes for pressure vessels and to take care of force and moments as enclosed in the specification. However in no case thickness of housing/ body shall be less than the thickness as specified in "Pipe size Table" enclosed in Data Sheet-A of SCS.
- 6.3 Adequate provision for future installation of Cathodic Protection for SCS (Sacrificial type shall be in Purchaser Scope) shall be kept by the bidder in the equipment.
- 6.4 Velocity in the pipe work shall be less than 1.5 m/ sec for pump suction and less than 2.2 m/ sec. in other pipe work. All valves upto 150 NB shall be ball valves. For higher sizes, gate/ globe/ B.F. valves shall be provided. All instrument valves shall be needle valves.

7.0 Self Cleaning Strainers :

7.1.1 Performance Guarantee Parameters shall be as under :

- Pressure drop in Self Cleaning Strainers in clean condition viz. after backwashing.

7.1.2 Bidder to note that bids shall be evaluated on account of pressure drop across Self Cleaning Strainers (in clean condition) & liquidated damages on account of not meeting the same shall be in accordance with following :

A) Bid Evaluation Criteria and Liquidated Damages:

The bids received shall be evaluated for Pressure drop across Self Cleaning strainers :

- The permissible limit of pressure drop across self cleaning strainers in clean condition shall be 0.6 MWC.
- If the pressure drops quoted are higher than above limit, the bids shall be technically loaded @ Rate as mentioned in Data Sheet-A on pro-rata basis per **0.1 MWC** pressure drop (viz. per unit).
- However no advantage shall be given for pressure drops quoted less than above permissible limit.
- The maximum acceptable limit for pressure drop across self cleaning strainer (with technical loadings) shall be 1.0 MWC.
The bids will be technically rejected for pressure drops quoted higher than above maximum limit.



TITLE : TECHNICAL SPECIFICATION
FOR

SELF CLEANING STRAINERS(SCS).

SPEC. NO: PE-TS-402-165-N003

VOLUME : II B

SECTION:C1

REV. NO. 0

DATE :11.09.2014

SHEET 6 OF 8

- The guaranteed pressure drops shall be demonstrated at site by vendors and if found higher shall be subject to LD @ twice the bid evaluation factor as above.

8.0 SPARES :

8.1 Recommended Spares :

Bidder to submit the list of recommended spares (along with prices) as per NIT required for three (3) years of reliable operation and maintenance of SCS for BHEL reference purpose only.

The recommended spares shall not be considered for evaluation and ordering purpose.

8.2 Mandatory Spares :

Mandatory Spares shall be as per Data Sheet-A or annexure enclosed with data sheet A.

9.0 Quality Plan

Bidder shall submit QP in the event of order based on the guidelines given in the specification & QP enclosed therein. QP will be subject to BHEL/ Customer approval and customer hold points for inspection/ testing shall be marked in the QP at the contract stage. Inspection/ testing shall be witnessed as per same apart from review of various test certificates/ Inspection records etc. Charges for 3rd party inspection (TUV/ equivalent) for imported components wherever required shall be included by bidder in the base price itself. Witness for all the test identified under agency "C" & "N" in Quality plan shall be by third party.

If BHEL or BHEL customer decides to witness the tests along with third party, the cost of travel of BHEL or BHEL customer shall be borne by BHEL or BHEL customer themselves.

10.0 DELIVERY & DRAWINGS/ DOCUMENTS DISTRIBUTION SCHEDULE :

- Delivery of Equipment for each project shall be as per NIT.
- Drawings submission schedule shall be as per NIT/as advised by Project Group.

11.0 The makes of various bought out items shall be subjected to purchaser's approval in the event of order.

12.0 It is mandatory for the bidders to submit along with the bid the deviations if any whether major or minor in the schedule of deviations only. ***In the absence of deviations listed in the schedule of deviations the offer shall be deemed to be in full conformity with the specification "non-withstanding" any thing else stated elsewhere in bidder's offer, data sheets etc. The implied/ indirect deviations in data sheets etc. Shall not***



TITLE : TECHNICAL SPECIFICATION
FOR
SELF CLEANING STRAINERS(SCS).

SPEC. NO: PE-TS-402-165-N003

VOLUME : II B

SECTION:C1

REV. NO. 0

DATE :11.09.2014

SHEET 7 OF 8

be binding on the purchaser.

13.0 The following documents shall be furnished by the bidder with his offer :

- Compliance certificate duly signed and stamped (Enclosed at Schedules).
- Guarantee schedule duly signed and stamped (Enclosed at Schedules).
- GA drawings of following with empty/ filled-ups.
 - GA of SCS (As applicable).
 - Debris Flushing pumps (if applicable)
 - Other equipments considered necessary for Layout/ Civil.
- Electrical Load Data (Enclosed at Vol. III of Specification)
- Schedule of Deviation (Enclosed at Schedules).

The bidder to note that load requirement furnished and finalised during tender stage shall only be provided by BHEL and any changes or additional requirement of Electrical load by bidder during contract stage shall be provided by BHEL with cost repercussions to the bidder.

NOTE: Apart from above, no other drawing/ document/ data sheet etc. shall be submitted along with the offer. If any drawing/ document etc. is submitted with the offer, same shall be considered as for 'Reference' purpose only and shall not be reviewed/ commented upon and any deviation, exclusion to scope, etc. taken in documents but not highlighted in the deviation schedule shall not be taken cognizance of.



TITLE : TECHNICAL SPECIFICATION
FOR
SELF CLEANING STRAINERS(SCS).

SPEC. NO: PE-TS-402-165-N003

VOLUME : II B

SECTION:C1

REV. NO. 0

DATE :11.09.2014

SHEET 8 OF 8

ANNEXURE-I

SELF CLEANING STRAINERS

SL.NO.	Projects	Size (NB)	Length of SCS (Excluding Counter Flange)	Scope of Counter Flange	Scope of nuts and bolts.
1.	2X500 MW NNTPS NEW NEYVELLI	600 NB	2000 mm	In Bidder's Scope	In Bidder's Scope

BOQ OF DEBRIS DISPOSAL PIPE WORK for each unit of 500 MW:

A) Individual line for each SCS

- i) Pipe - 10M
- ii) 90 elbow -4 Nos

B) Common line

- i) Pipe - 90M
- ii) 90 elbow -10 Nos.
- iii) Unequal Tee - 2 Nos

ANNEXURE-II

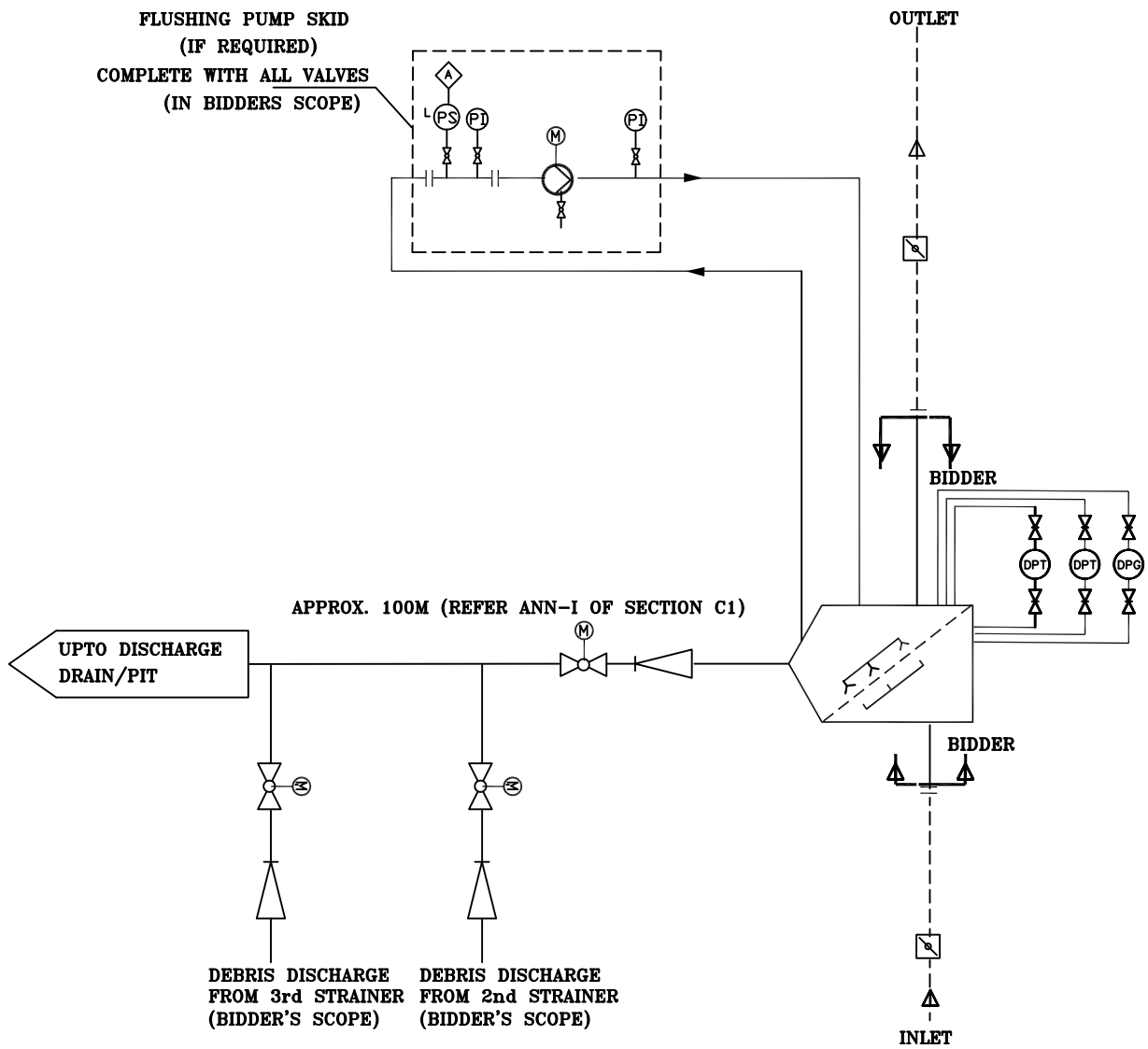

NOTE :-

1. SCHEMATIC SHOWN IS TYPICAL FOR ONE SCS, SHALL BE IDENTICAL FOR THE SECOND SCS.
2. INSTRUMENTS/ANNUNCIATIONS/ INTERLOCKS INDICATED IN THE SCHEME ARE TENTATIVE, SHALL BE PROVIDED AS PER APPROVED DRGS./ DOCUMENTS/ CONTROL PHILOSOPHY IN THE EVENT OF ORDER.
3. COUNTERFLANGES FOR SCS ARE INCLUDED IN BIDDERS SCOPE. ALL INTERCONNECTING / DEBRIS DISPOSAL PIPING IS INCLUDED IN BIDDERS SCOPE.
4. BIDDER'S SCOPE OF SUPPLY ALSO INCLUDES :
 - a) ALL VALVES & NRVs ON BIDDER'S INTERCONNECTING /DEBRIS DISPOSAL PIPING ALONGWITH THEIR COUNTER FLANGES.
 - b) FLUSHING PUMP SKID, IF REQUIRED COMPLETE WITH FLUSHING PUMP, VALVES, INSTRUMENTS ETC.
5. PURCHASER BIDDER'S SCOPE OF SUPPLY

**FLOW DIAGRAM FOR
SELF CLEANING STRAINER**



**TITLE : TECHNICAL SPECIFICATION
FOR
SELF CLEANING STRAINERS (SCS)**

SPEC. NO. PE-TS-402-165-N003

VOLUME : IIB

SECTION : D

REV. NO. 0

DATE :30.05.2014

SHEET 1of 1

**SECTION C2
SELF CLEANING STRAINERS
ELECTRICAL DETAILS**



TECHNICAL SPECIFICATION FOR
SCS
(ELECTRICAL PORTION)

SPECIFICATION NO.
VOLUME II B
SECTION-C
REV DATE 13.05.2014
PAGE 1 OF 1

SPECIFIC TECHNICAL REQUIREMENTS: ELECTRICAL

1.0 EQUIPMENT & SERVICES TO BE PROVIDED BY BIDDER/ PURCHASER

- 1.1 Scope for supply, and erection & commissioning of various equipment forming part of electrical system for this package shall be as per Annexure-I to Section – C [Scope of Work (Electrical)].
- 1.2 Make of various equipment/ items in the scope of bidder shall be to approval of owner during detailed engineering stage without any commercial implications.
- 1.3 Bidder shall furnish all AC as well as DC loads required for the system at different voltage levels (eg. 415V AC, 240 V AC, 220 V DC etc.) of all types, such as motor feeders, supply feeders in PEM format along with the offer.
- 1.4 All electrical equipment shall be suitable for the power supplies, fault levels and climatic conditions indicated in project information enclosed with the specification.
- 1.5 All drawings, data sheets, Quality Plan, calculations, test reports, test certificates, etc. shall be submitted during detailed engineering stage as per formats enclosed. The same shall be subject to approval without any commercial implications.
- 1.6 Technical requirements shall be as per specifications listed in Clause 4.1, 4.2 & 4.3 below.

3.0 DOCUMENTS TO BE SUBMITTED ALONG WITH BID

- 3.1 Bidder shall confirm total compliance to the electrical specification without any deviation from the technical/ quality assurance requirements stipulated. In line with this, the bidder as technical offer shall furnish two signed and stamped copies of the following:
 - a) A copy of this sheet "Electrical Equipment Specification for SCS and sheet "Electrical Scope between BHEL and Vendor" with bidder's signature and company stamp.
 - b) List of Erection and Commissioning spares.
 - c) List of Erection & Maintenance tools & tackles.
 - d) Electrical load requirement in the load data format.
- 3.2 No technical submittal such as copies of data sheets, drawings, write-up, quality plans, type test certificates, technical literature, etc, is required during tender stage. Any such submission even if made, shall not be considered as part of offer.

4.0 LIST OF ENCLOSURES

- 4.1 Electrical scope between BHEL & vendor (Annexure-I).
- 4.2 Technical specification no. PE-SS-999-506-E101, Data Sheets (A & C) for 415V Electric Motors.
- 4.3 Quality Plan for motors.
- 4.4 Load data format (Annexure-II).

ANNEXURE – I TO SECTION – C: STANDARD ELECTRICAL SCOPE BETWEEN BHEL AND VENDOR

PACKAGE: SCS

PROJECT: 2X500 MW NNTPS TPP

S.NO	DETAILS	SCOPE SUPPLY	SCOPE E&C	REMARKS
1	415V MCC	BHEL ^{\$}	BHEL ^{\$}	1. 415 V AC/240 V AC supply shall be provided by BHEL based on load data provided by vendor at contract stage for all equipment supplied by vendor as part of contract including power supply equipment (battery charger etc) required for the PLC/control panel (as applicable) for the system supplied by vendor. 2. Interposing relays (RE 302 of Jyoti make or equivalent), if required for PLC and microprocessor based systems, shall be provided by BHEL in MCCs. Requirement of these relays shall be furnished by vendor during detailed engineering stage.
2	Local Push Button Station (for motors)	BHEL ^{\$}	BHEL ^{\$}	Located near the motor.
3	Power cables, control cables and screened control cables for a) both end equipment in BHEL's scope b) both end equipment in vendor's scope c) one end equipment in vendor's scope	BHEL ^{\$} Vendor BHEL ^{\$}	BHEL ^{\$} Vendor BHEL ^{\$}	1. Sizes and quantity of cables required shall be informed by vendor at contract stage (based on inputs provided by BHEL). Finalisation of cable sizes shall be done by BHEL. Vendor shall provide lugs & glands accordingly. 2. Laying of cables by BHEL except for cabling in vendor scope. 3. Termination at BHEL equipment terminals by BHEL. 4. Termination at Vendor equipment terminals by Vendor.
4	Any special type of cable like compensating, co-axial, prefab, MICC, fibre optical etc.	Vendor	Vendor	
5	Cable trays, accessories & cable trays supporting system	BHEL ^{\$}	BHEL ^{\$}	
6	Cable glands and lugs for equipments supplied by Vendor	Vendor	Vendor	1. Double compression Ni-Cr plated brass cable glands 2. Solder less crimping type heavy duty tinned copper lugs for power cables 3. Solder less crimping type heavy duty copper lugs for control cables.
7	Conduit and conduit accessories for cabling between equipments supplied by vendor	Vendor	Vendor	Conduits shall be medium duty, hot dip galvanised cold rolled mild steel rigid conduit as per IS: 9537. Makes of conduits shall be subject to customer/ BHEL approval at contract stage.
8	Lighting	BHEL ^{\$}	BHEL ^{\$}	
9	Equipment grounding & lightning protection	BHEL ^{\$}	BHEL ^{\$}	
10	Below grade grounding	BHEL ^{\$}	BHEL ^{\$}	
11	LT Motors with base plate and foundation hardware	Vendor	Vendor	Makes shall be subject to customer/ BHEL approval at contract stage.
12	Mandatory spares	Vendor	-	Vendor to quote as per specification.
13	Recommended O & M spares, E & C spares, erection &	Vendor	-	As per specification

ANNEXURE – I TO SECTION – C: STANDARD ELECTRICAL SCOPE BETWEEN BHEL AND VENDOR

PACKAGE: SCS

PROJECT: 2X500 MW NNTPS TPP

S.NO	DETAILS	SCOPE SUPPLY	SCOPE E&C	REMARKS
	maintenance tools & tackle.			
14	Any other equipment/material/service required for completeness of system but not specified above (to ensure trouble free and efficient operation of the system).	Vendor	Vendor	
15	a) Input cable schedules (C & I) b) Cable interconnection details for above c) Cable block diagram	Vendor Vendor Vendor	- - -	Cable listing for C & I systems for vendor supplied equipment shall be furnished during detail engineering by vendor in soft copies in the BHEL cable schedule format.
16	Equipment layout drawings	Vendor	-	For ensuring cabling requirements are met, vendor shall furnish layout drawings (both in print form as well as in AUTOCAD) of the complete plant (including electrical area) indicating location and identification of all equipments requiring cabling, and shall incorporate cable trays routing details marked on the drawing as per PEM interface comments. Electrical equipment layout drawing shall be to BHEL approval.
17	Electrical Equipment GA drawing	Vendor	-	For necessary interface review.

NOTES:

1. Make of all electrical equipments/items supplied shall be reputed make & shall be subject to approval of BHEL/customer after award of contract.
2. All QPs shall be subject to approval of BHEL/customer after award of contract without any commercial implication.
3. For skid mounted system, 2 nos. (1W+1S) supply of 415 V, 3 phase, 4 wire AC shall be provided by BHEL/Customer. Complete skid including changeover between feeder/starters/LCP/inter-locks/protection devices / any other supply etc. shall be in bidder's scope only.
4. Painting: The painting for electrical equipment shall be epoxy based with suitable additives. The paint shall be corrosion proof epoxy based of approved class and paint thickness shall be within 100 to 150micron. The vendor shall furnish the complete painting details during detailed engineering.
5. \$: Shall be in customer scope where equipment are supplied by customer.

SPECIFIC ELECTRICAL REQUIREMENT FOR SCS

SL.NO.	PARAMETERS	UNIT	NLC
	MOTOR		
1	DESIGN AMBIENT TEMP	DEG. C	50
2	VOLTAGE SUPPLY AND VARIATION	VOLT	415V, \pm 10%
3	FREQUENCY WITH VARIATION	Hz	50 (+) 5% to (-) 3%
4	COMBINED VOLTAGE & FREQUENCY VARIATION		10%
5	MAX ACCEPTABLE RATING OF MOTOR AT 415 V	KW	160 KW & below
6	SYSTEM FAULT LEVEL AND ITS DURATION	KA	50kA, 1sec
7	SUTABILITY OF TERMINAL BOX FOR FAULT LEVEL AND DURATION		50 KA, 0.25 sec
8	CLASS OF INSULATION & TEMP RISE LIMITED TO		Class-F or better and temp rise limited to Class-B
9	MIN. STARTING VOLTAGE		85%
10	MOTOR RATING FOR SINGLE PHASE SUPPLY		0.22 kW & Below
11	MAXIMUM LOCKED ROTOR CURRENT	% OF FLC	As per IS 12615
12	ACCEPTABLE NOISE LEVEL	DB	Noise level for all motors shall be limited to 85dB(A) at 1.5 m (in line with IS 12065)
13	TYPE OF STARTER PROVIDED IN MCC		DOL
14	DOP OF ENCLOSURE		IP-55 FOR OUTDOOR & IP-54 for indoor resp.
15	SPACE HEATER REQUIREMENT	<30kW	30KW & ABOVE
16	PAINT SHADE		DURING DETAIL ENGINEERING.
17	ENERGY EFFICIENT		(I) ENERGY EFFICIENT TYPE IE1 AS PER IS 12615 (II) For LT Motors above 50kW, type test reports for type tests as per IS: 325/ IS: 12615 conducted on equipment similar to those proposed to be supplied and carried out within last five years from the date of bid opening viz. February 2012 shall be submitted. However, if such reports are not available, one motor of each type shall be subjected to type tests for free of cost.



TITLE : TECHNICAL SPECIFICATION
FOR
SELF CLEANING STRAINERS (SCS)

SPEC. NO. PE-TS-402-165-N003

VOLUME : IIB

SECTION : D

REV. NO. 0

DATE :30.05.2014

SHEET 1of 1

SECTION C3
SELF CLEANING STRAINERS
C&I DETAILS

**C&I SPECIFICATION FOR SCS
FOR NEW NEYVELI TPP (TG PACKAGE)**

SELF CLEANING STRAINER - C&I REQUIREMENTS

S.NO.	PROJECT	NEW NEYVELLI TPP (TG PACKAGE)
1.00	SYSTEM	SCS
2.00	COMMON / PER UNIT	REFER NOTES
3.00	CONTROL SYSTEM	PLC
3.10	PROCESSOR CONFIGURATION FOR PLC SYSTEM	REDUNDANT WITH HOT STAND BY
4.00	LOCATION OF CONTROL SYSTEM	LOCAL TO SCS
4.10	CONTROL SYSTEM SCOPE (BIDDER/ BHEL/ CUSTOMER)	BIDDER
5.00	HARDWIRED INTERFACE WITH DCS (Y/N)	Y
5.10	PURPOSE OF HARDWIRED INTERFACE WITH DCS	FOR FAULT CONTACTS
5.11	a) COMMAND FROM DCS (Y/N)	N
5.12	b) STATUS FEEDBACK TO DCS (Y/N)	N
5.13	c) GROUP FAULT ALARM TO DCS (Y/N)	Y
6.00	SOFTLINK TO DCS (Y/N)	Y
6.10	PURPOSE OF SOFTLINK TO DCS	MONITORING
6.11	a) COMMAND INTERFACE WITH DCS (Y/N)	N
6.12	b) STATUS MONITORING IN DCS (Y/N)	Y
7.00	PROTECTION CLASS FOR PLC / RIO PANEL	IP54
8.00	CONTROL FROM PB's ON LCP/OWS	CONTROL FROM PB's ON LCP
9.00	ANNUNCIATION ON LCP (Y/N) -- IF Y, MIN NO. OF HARDWIRED ALARMS / INDICATIONS	YES- BIDDER TO PROPOSE MIN. NO. OF ALARMS/INDICATIONS
9.10	MIMIC ON LCP (Y/N)	Y

SELF CLEANING STRAINER - C&I REQUIREMENTS

S.NO.	PROJECT	NEW NEYVELLI TPP (TG PACKAGE)
10.00	CONTROL FROM DCS IN CCR (Y/N)	N
11.00	TYPE OF SOFTLINK (TP/OFC)	OFC
11.10	COMMUNICATION CABLE SCOPE (BIDDER/ BHEL)	BIDDER
11.20	REDUNDANT CABLE (Y/N)	Y
11.30	PROTOCOL	OPC
12.00	RIO / RPU (Y/N)	N
13.00	## NO. OF OWS / LAPTOP/LCD	A) 1 NO. LAPTOP PER PLC LOADED WITH ENGG. S/W B) 1 NO. OF LCD DISPLAY ON EACH PLC PANEL .
13.10	SIZE OF OWS/ CRT OR LCD	15" LCD
14.00	NO. OF PRINTER	N
14.10	PRINTER SIZE AND TYPE	N
15.00	POWER SUPPLY AVAILABLE FOR BALL MONITOR (24V DC / 110 V AC UPS / 230 V AC UPS)	A) 230 V AC UPS B) 24VDC TO BE DERIVED FROM PLC PANEL
15.10	&& POWER SUPPLY AVAILABLE FOR PLC PANEL (3PHASE, 415 V AC/ 1PHASE, 110 V UPS/ 1PHASE, 230 V UPS)	3 PHASE, 415 V AC AT SINGLE POINT
15.20	REDUNDANT FEEDERS (R) / NON-REDUNDANT (NR) FEEDERS FOR POWER SUPPLY	R
15.30	** UPS BATTERY CONFIGURATION (1X100% / 2X100%)	2 X 100 %
15.40	BATTERY TYPE (LEAD ACID/ NI-Cd)	Lead Acid 'Plante' type
15.50	BATTERY BACK-UP TIME (in minutes)	30
16.00	ACTUATOR WITH INTEGRAL STARTER (Y/N)	N
17.00	PG/ DPG/ PS/ DPS/ PT/ DPT PER SCS	DPT = 2 nos. DPI = 1 no. (ACROSS EACH SCS)

SELF CLEANING STRAINER - C&I REQUIREMENTS

S.NO.	PROJECT	NEW NEYVELLI TPP (TG PACKAGE)
18.00	PROJECT SPECIFIC INFO	NA
19.00	REMARKS	1) DISTANCE BETWEEN CCR AND THE PLC PANEL WILL BE AROUND 150 METRES.
20.00	NOTES:	
	1. && ALL POWER SUPPLY REQUIREMENTS FOR INDIVIDUAL SUB-SYSTEMS/ COMPONENTS EG. BALL MONITOR, SOL VALVES ETC SHALL BE DERIVED BY THE VENDOR FROM THIS POWER SUPPLY.	
	2. ** THE UPS FOR PLC SHALL BE IN BIDDER'S SCOPE WITH 2X100% CONFIGURATION.	
	3. BIDDER TO PROVIDE INPUT/OUTPUT LIST, DRIVES LIST, JUNCTION BOX SCHEDULE AND TERMINATION DETAILS, RECOMMENDED CONTROL LOGICS / WRITE-UP ETC. DURING DETAILED ENGINEERING	
	4. ALL CABLES & CABLE ENGINEERING SHALL BE IN BIDDER'S SCOPE.	
	5. ## LAPTOPS SHALL BE OF LATEST CONFIGURATION WITH PROGRAMMING SOFTWARE & COMMUNICATION CABLE.	
	6. SCS SHALL HAVE ONE COMMON STARTER PANEL (SWITCH GEAR PANEL) CUM PLC PANEL.	
	7. COLOUR OF THE PANELS SHALL BE RAL 7035 FOR EXTERIOR & BRILLIANT WHITE FOR INTERNAL. THIS SHALL BE DECIDED DURING DETAIL ENGINEERING	
	8. INSTRUMENT RACK AND JUNCTION BOXES SHALL BE IN BIDDER'S SCOPE OF SUPPLY.	
	9. BIDDER TO FURNISH ELECTRICAL LOAD DATA DURING DETAILED ENGINEERING.	
	10. ALARM FACIA SHALL BE UNDER BIDDER'S SCOPE. NUMBER OF FACIA SHALL BE DECIDED DURING DETAILED ENGINEERING.	
	11. PLC BASED CONTROL SYSTEM SHALL BE PROVIDED UNIT WISE. THE PLC SYSTEM SHALL BE PROVIDED WITH NECESSARY INTERFACE HARDWARE AND SOFTWARE FOR DUAL FIBER OPTIC CONNECTIVITY INCLUDING LIU (LIGHT INTERFACE UNIT), PATCH CORDS ETC. AT PLC END FOR INTERCONNECTION WITH DDCMIS LOCATED AT MAIN PLANT CONTROL ROOM FOR MONITORING OF SIGNAL INFORMATION.	
	LEGEND:	
	CCR- COMMON CONTROL ROOM	
	DCS- DISTRIBUTED CONTROL SYSTEM	
	PLC- PROGRAMMABLE LOGIC CONTROLLER	
	RPU - REMOTE PROCESSING UNIT	

	SPECIFICATION FOR MOTORISED VALVE ACTUATOR		SPECIFICATION NO.:	
			VOLUME	
			SECTION	
			REV. NO.	DATE:
			SHEET	1 OF 3
Data Sheet A & B				
DATA SHEET-A (TO BE FILLED BY PURCHASER)			DATA SHEET-B (TO BE FILLED-UP BY BIDDER)	
GENERAL*	* PROJECT			
	OFFER REFERENCE			
	* TAG NO. SERVICE			
	* DUTY	<input type="checkbox"/> ON / OFF	<input type="checkbox"/> INCHING	
	* LINE SIZE (inlet/outlet): MATERIAL			
	* VALVE TYPE	<input type="checkbox"/> GLOBE <input type="checkbox"/> GATE <input type="checkbox"/> REG. GLOBE <input type="checkbox"/> BUTTERFLY		
	* OPENING / CLOSING TIME			
	* WORKING PRESSURE			
	AMBIENT CONDITION	SHALL BE SUITABLE FOR CONTINUOUS OPERATION UNDER AN AMBIENT TEMP. OF 0-55 DEG C AND RELATIVE HUMIDITY OF 0-95%		
	VALVE SEAT TEST PRESS	BIDDER TO SPECIFY		
	REQUIRED VALVE TORQUE	BIDDER TO SPECIFY		
	ACTUATOR RATED TORQUE	BIDDER TO SPECIFY		
CONSTRUCTION AND SIZING	CONSTRUCTION	TOTALLY ENCLOSED, DUST TIGHT, WEATHER PROOF, IP:67		
	MECHANICAL POSITION INDICATOR	TO BE PROVIDED FOR 0-100% TRAVEL		
	BEARINGS	DOUBLE SHIELDED, GREASE LUBRICATED ANTI-FRICTION.		
	GEAR TRAIN FOR LIMIT SWITCH/TORQUE SWITCH OPERATION	METAL (NOT FIBRE GEARS). SELF-LOCKING TO PREVENT DRIFT UNDER TORQUE SWITCH SPRING PRESSURE WHEN MOTOR IS DE-ENERGIZED.		
	SIZING	OPEN/CLOSE AT RATED SPEED AGAINST DESIGNED DIFFERENTIAL PRESSURE AT 90% OF RATED VOLTAGE. FOR ISOLATING SERVICE THREE SUCCESSIVE OPEN-CLOSE OPERATIONS OR 15 MINS. WHICHEVER IS HIGHER. FOR REGULATING SERVICE - 150 STARTS/HR MINIMUM		
HANDWHEEL	* REQUIRED	<input checked="" type="checkbox"/> YES	<input type="checkbox"/> NO	
	* ORIENTATION	<input type="checkbox"/> TOP MOUNTED	<input type="checkbox"/> SIDE MOUNTED	
	*TO DISENGAGE AUTOMATICALLY DURING MOTOR OPERATION.			
ELECTRIC ACTUATOR	ACTUATOR MAKE/MODEL	BIDDER TO SPECIFY		
	MOTOR MAKE / MODEL / TYPE / RATING (KW)	BIDDER TO SPECIFY		
	@ MOTOR TYPE	IE1 TYPE AS PER IS: 12615, SQUIRREL CAGE INDUCTION MOTOR SUITABLE FOR DOL STARTING.		
	ACTUATOR APPLICABLE WIRING DIAGRAM	<input checked="" type="checkbox"/> ENCLOSED (BIDDER TO CONFIRM) <input checked="" type="checkbox"/> DRG. NO. 4-V-MISC-90271 R11		
	COLOUR SHADE	<input checked="" type="checkbox"/> BLUE (RAL 5012), To be decided during detail engg.		
	PAINT TYPE (## Refer Notes)	<input type="checkbox"/> ENAMEL	<input checked="" type="checkbox"/> EPOXY	<input type="checkbox"/>
	SHAFT RPM	BIDDER TO SPECIFY		
	OLR SET VALUE	BIDDER TO SPECIFY		
	@ STARTING / FULL LOAD CURRENT	600% OF FLC INCLUSIVE OF I.S. TOLERANCE		
	NO. OF REV FOR FULL TRAVEL	BIDDER TO SPECIFY		
	@ PWR SUPP TO MTR / STARTER	415V, 3PH, AC	DOL STARTER	
	@ CONTROL VOLTAGE REQUIREMENT	TO BE DERIVED FROM THE POWER SUPPLY TO THE STARTER <input type="checkbox"/> 230 V <input type="checkbox"/> 110 V		
	@ ENCLOSURE CLASS OF MOTOR	<input checked="" type="checkbox"/> IP 67 <input type="checkbox"/> FLAME PROOF		
	@ INSULATION CLASS	CLASS-F TEMP. RISE LIMITED TO CLASS-B		

	SPECIFICATION FOR MOTORISED VALVE ACTUATOR		SPECIFICATION NO.:		
			VOLUME		
			SECTION		
			REV. NO.	DATE:	
			SHEET	2	OF 3
Data Sheet A & B					
DATA SHEET-A (TO BE FILLED BY PURCHASER)			DATA SHEET-B (TO BE FILLED-UP BY BIDDER)		
	@ WINDING TEMP PROTECTION	<input checked="" type="checkbox"/> THERMOSTAT (3 Nos.,1 IN EACH PHASE) <input type="checkbox"/> -----			
	SINGLE PHASE / WRONG PHASE SEQUENCE PROTECTION	REQUIRED			
INTEGRAL STARTER	INTEGRAL STARTER	<input type="checkbox"/> REQUIRED <input checked="" type="checkbox"/> NOT REQUIRED			
	TYPE OF SWITCHING DEVICE	<input type="checkbox"/> CONTACTORS <input type="checkbox"/> THYRISTORS			
	TYPE	<input type="checkbox"/> CONVENTIONAL <input type="checkbox"/> SMART (NON-INTRUSIVE)			
	IF SMART				
	a) SERIAL LINK INTERFACE	<input type="checkbox"/> INTEGRAL <input type="checkbox"/> FIELD MOUNTED			
	b) SERIAL LINK PROTOCOL	<input type="checkbox"/> FOUNDATION FIELD-BUS <input type="checkbox"/> PROFI-BUS <input type="checkbox"/> DEVICE NET <input type="checkbox"/>			
	c) SERIAL LINK MEDIA	<input type="checkbox"/> TWISTED PAIR Cu-CBL <input type="checkbox"/> CO-AXIAL Cu-CBL <input type="checkbox"/> OFC			
	d) HAND HELD PROGRAMMER	<input type="checkbox"/> REQUIRED <input type="checkbox"/> NOT REQUIRED			
	e) TYPE OF HAND HELD PROGRAMMER	<input type="checkbox"/> BLUETOOTH <input type="checkbox"/> INFRARED <input type="checkbox"/>			
	f) MASTER STATION	<input type="checkbox"/> REQUIRED <input type="checkbox"/> NOT REQUIRED			
	g) MASTER STN INTRFACE WITH DCS	<input type="checkbox"/> MODBUS <input type="checkbox"/> TCP/IP			
	h) DETAILS OF SPECIAL CABLE	<input type="checkbox"/> ENCLOSED <input type="checkbox"/> NOT REQUIRED			
	STEP DOWN CONT. TRANSFORMER	<input type="checkbox"/> REQUIRED			
	OPEN / CLOSE PB	<input type="checkbox"/> REQUIRED <input type="checkbox"/> NOT REQUIRED			
	STOP PB	<input type="checkbox"/> REQUIRED <input type="checkbox"/> NOT REQUIRED			
	INDICATING LAMPS	<input type="checkbox"/> REQUIRED <input type="checkbox"/> NOT REQUIRED			
	LOCAL REMOTE S/S	<input type="checkbox"/> REQUIRED <input type="checkbox"/> NOT REQUIRED			
STATUS CONTACTS FOR MONITORING	<input type="checkbox"/> REQUIRED <input type="checkbox"/> NOT REQUIRED				
INTEGRAL STARTER DISTURBED SIGNAL	REQUIRED (O/L RELAY OPERATED, CONT./POWER SUPPLY FAILED, S/S IN LOCAL, TORQUE SWITCH OPTD. MID WAY)				
INTERPOSING RELAY/OPTO COUPLER (Applicable for integral Starter)	TYPE OF ISOLATING DEVICE	<input type="checkbox"/> INTERPOSING RELAY <input type="checkbox"/> OPTO COUPLER <input type="checkbox"/> EITHER			
	QUANTITY	<input type="checkbox"/> 2 NOs. <input type="checkbox"/> 3 NOs.			
	DRIVING VOLTAGE	<input checked="" type="checkbox"/> 20.5 – 24V DC <input type="checkbox"/> _____ V DC			
	DRIVING CURRENT	<input checked="" type="checkbox"/> 125mA MAX <input type="checkbox"/> _____ mA MAX			
	LOAD RESISTANCE	<input checked="" type="checkbox"/> > 192 ohms - <25 k ohms <input type="checkbox"/> > _____ ohms - < _____ ohms			
TORQUE SWITCH (Not Applicable for Smart Actuator) (\$\$ Refer Notes)	MFR & MODEL NO.	BIDDER TO SPECIFY			
	OPEN / CLOSE	<input checked="" type="checkbox"/> 1 No. <input type="checkbox"/> 2Nos. / <input checked="" type="checkbox"/> 1 No. <input type="checkbox"/> 2Nos			
	CONTACT TYPE	2 NO + 2 NC			
	RATING	5A 240V AC AND 0.5A 220V DC			
	CALIBRATED KNOBS(OPEN&CLOSE TS)	REQUIRED FOR SETTING DESIRED TORQUE			
	ACCURACY	+3% OF SET VALUE			
LIMIT SWITCH (Not Applicable for Smart Actuator) (\$\$ Refer Notes)	MFR & MODEL NO.	BIDDER TO SPECIFY			
	OPEN : INT : CLOSE	<input checked="" type="checkbox"/> 1 No <input type="checkbox"/> 2 Nos. <input type="checkbox"/> 2 Nos. (ADJ.) <input checked="" type="checkbox"/> 1 No. <input type="checkbox"/> 2Nos.			
	CONTACT TYPE	2 NO + 2 NC			
	RATING (AC / DC)	5A 240V AC AND 0.5A 220V DC			

	SPECIFICATION FOR MOTORISED VALVE ACTUATOR		SPECIFICATION NO.:	
			VOLUME	
			SECTION	
			REV. NO.	DATE:
			SHEET	3 OF 3
Data Sheet A & B				
DATA SHEET-A (TO BE FILLED BY PURCHASER)			DATA SHEET-B (TO BE FILLED-UP BY BIDDER)	
POSITION TRANSMITTER	POSITION TRANSMITTER (For inching duty & other specific applications)	<input checked="" type="checkbox"/> REQUIRED <input type="checkbox"/> NOT REQUIRED		
	MFR & MODEL NO.	BIDDER TO SPECIFY		
	TYPE	<input type="checkbox"/> ELECTRONIC (2 WIRE) R/I CONVERTER <input checked="" type="checkbox"/> ELECTRONIC (2 WIRE) CONTACTLESS		
	SUPPLY	<input checked="" type="checkbox"/> 24V DC <input type="checkbox"/>		
	OUTPUT	<input checked="" type="checkbox"/> 4-20mA		
	ACCURACY	$\pm 1\%$ FS		
SPACE HEATER	@SPACE HEATER	REQUIRED		
	@ POWER SUPPLY (NON INTEGRAL)	230V AC,1 PH.,50 Hz		
	@ POWER SUPPLY (INTEGRAL)	BIDDER TO SPECIFY		
	@ RATING	FOR MOTORS WITH RATING >30 KW		
TERMINAL BOX	ACTUATOR/MOTOR TERMINAL BOX	REQUIRED		
	ENCL CLASS ACTUATOR/MOTOR T.B.	<input type="checkbox"/> IP 68 @ <input type="checkbox"/>		
	@ EARTHING TERMINAL	8 SWG GI WIRE		
	PLUG & SOCKET(9 PIN) (FOR COMM, LS/TS FEED BACK, PoT)	<input type="checkbox"/> REQUIRED <input checked="" type="checkbox"/> NOT REQUIRED <input type="checkbox"/> 2 NOS. <input type="checkbox"/>		
CABLE GLANDS	@ POWER CABLE GLAND	SIZE:DDE		
	@ SPACE HEATER CABLE GLAND	SIZE:DDE		
	OTHER CONTROL CABLE GLANDS-1	<input type="checkbox"/> 1No. for BFV of CW PUMP(Cable size 2Px1.5mm2)		
	OTHER CONTROL CABLE GLANDS-2	QUANTITY & SIZE: 1no., 2.5 sq. mm		
WEIGHT	TOTAL WEIGHT (ACTUATOR + ACCESSORIES)	BIDDER TO SPECIFY		_____ Kg.
NOTES: 1. SCOPE: DESIGN, MANUFACTURE, INSPECTION, TESTING AND DELIVERY TO SITE OF ELECTRIC ACTUATOR FOR INCHING OR OPEN / CLOSE DUTY. 2. CODES & STANDARDS: DESIGN AND MATERIALS USED SHALL COMPLY WITH THE RELEVANT LATEST NATIONAL AND INTERNATION STANDARD. AS A MINIMUM, THE FOLLOWING STANDARDS SHALL BE COMPLIED WITH: IS-9334, IS-2147, IS-2148, IS-325, IS-2959, IS-4691, IS 12615 AND IS-4722 3. TEMPERATURE RISE SHALL BE RESTRICTED TO 70 DEG. C FOR AMBIENT TEMPERATURE OF 50 DEG C. 4. CABLE GLANDS OF DOUBLE COMPRESSION TYPE, BRASS MATERIAL, WITH NICKEL COATING SHALL BE PROVIDED. 5. THE TORQUE SWITCHES SHALL BE PROVIDED WITH MECHANICAL LATCHING DEVICE TO PREVENT OPERATION WHEN UNSEATING FROM THE END POSITIONS. THE LATCHING DEVICE SHALL UNLATCH AS SOON AS THE VALVE LEAVES THE END POSITION. IF SUCH PROVISION IS NOT POSSIBLE, THE TORQUE SWITCHES SHALL BE BYPASSED BY END-POSITION LIMIT SWITCHES WHICH OPENS ON VALVE LEAVING END POSITION.THESE LIMIT SWITCHES ARE ADDITIONAL TO THE NUMBER OF LIMIT SWITCHES SPECIFIED ELSEWHERE. 6. THE MOTOR SHALL OPERATE SATISFACTORILY UNDER THE +/- 10% SUPPLY VOLTAGE VARIATION AT RATED FREQUENCY, -5% TO +3% VARIATION IN FREQUENCY AT RATED SUPPLY VOLTAGE, SIMULTANEOUS VARIATION IN VOLTAGE & FREQUENCY THE SUM OF ABSOLUTE PERCENTAGE NOT EXCEEDING 10%. 7. THE MOTOR SHALL BE SUITABLE FOR DIRECT ON LINE STARTING. \$\$ TORQUE SWITCH & LIMIT SWITCH SHALL ACT INDEPENDENT OF EACH OTHER. TANDEM OPERATION IS NOT ACCEPTABLE. ## EPOXY PAINT IS RECOMMENDED FOR COASTAL AREAS.				
NAME SIGNATURE DATE	PREPARED BY	CHECKED BY	APPROVED BY	VENDOR COMPANY SEAL
				NAME
				SIGNATURE
				DATE
NOTES* = TO BE FILLED BY MPL (LEAD AGENCY). @= TO BE FILLED BY ES				

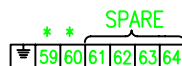
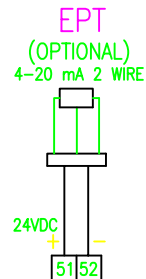
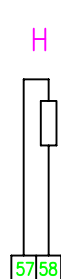
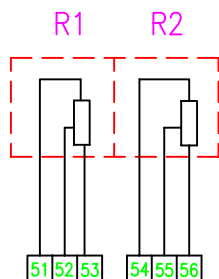
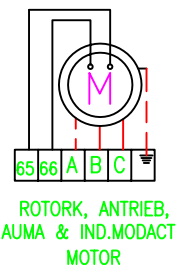
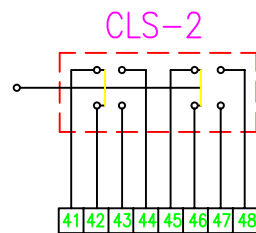
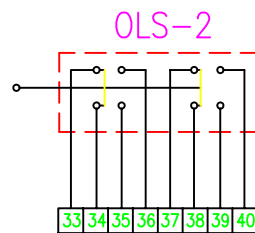
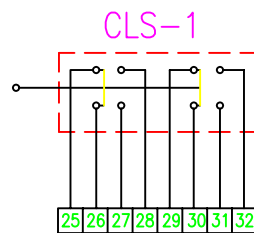
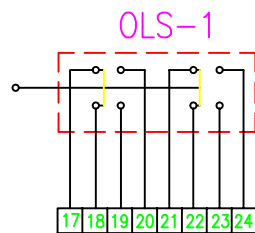
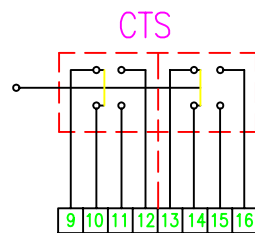
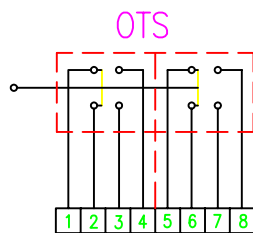
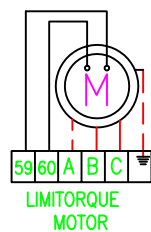

* - SPARE FOR ROTORK, AUMA, ANTRIEB & IND.MODACT

SWITCHES - ALL ARE POTENTIAL FREE AND TWO PAIR OF CONTACTS CAN BE USED FOR DIFFERENT SUPPLY
THERMOSTAT - 65-66 (ROTORK, AUMA, ANTRIEB & IND.MODACT), 59-60 (LIMITORQUE).

EPT - ELECTRONIC POSITION TRANSMITTER (POTENTIOMETRIC TYPE, FOR INCHING DUTY)

THERMOSTAT TERMINALS - TERMINATED IN MOTOR TB IN ANTRIEB & IND.MODACT AND IN MAIN TB IN OTHER MAKES

CTS - TORQUE SWITCHES FOR CW ROTATION (CLOSE) - 2 NO+2 NC

OTS - TORQUE SWITCHES FOR CCW ROTATION (OPEN) - 2 NO+2 NC

OLS-1, OLS-2 - LIMITSWITCHES FOR POSITION OPEN - 2 NO+2 NC

CLS-1, CLS-2 - LIMITSWITCHES FOR POSITION CLOSE - 2 NO+2 NC

OTS, CTS - TWO INDEPENDENT SWITCHES IN ANTRIEB & LIMITORQUE

OLS-2 & CLS-2 - CAM DISC IN ROTORK & ANTRIEB

R1-R2- POTENTIOMETER 2 x 100 OHMS

H - SPACE HEATER 1ϕ 240V AC SUPPLY

M - MOTOR 3ϕ 415V 50 Hz AC SUPPLY

SETTING PROCEDURE OF POSITION LIMIT AND TORQUE SWITCH				
VALVES	OPEN		CLOSE	
	MAIN	BACK UP	MAIN	BACK UP
GATE VALVE OF 100 mm AND ABOVE IN 1500 CL AND ABOVE RATINGS	OLS	OTS	CLS	CTS
ALL OTHER GATE & GLOBE VALVES	OLS	OTS	CTS	⊙

⊙ - CLS NOT TO BE CONNECTED IN TRIP CIRCUIT

NOTE:

1. BYPASS OTS FOR INITIAL 5% OF TRAVEL (FOR GATE VALVES ONLY)
2. CONNECT THERMOSTAT WITHOUT FAIL IN THE STARTER CIRCUIT

CONTACT DEVELOPMENT DIAGRAM

OTS	1-2	OFF AT OVER TORQUE DURING OPENING TRAVEL				
	3-4	ON AT OVER TORQUE DURING OPENING TRAVEL				
	5-6	OFF AT OVER TORQUE DURING CLOSING TRAVEL				
CTS	7-8	ON AT OVER TORQUE DURING CLOSING TRAVEL				
	9-10	OFF AT OVER TORQUE DURING CLOSING TRAVEL				
	11-12	ON AT OVER TORQUE DURING CLOSING TRAVEL				
OLS-1	13-14					
	15-16					
	17-18					
CLS-1	19-20					
	21-22					
	23-24					
OLS-2	25-26					
	27-28					
	29-30					
CLS-2	31-32					
	33-34					
	35-36					
SWITCH	37-38					
	39-40					
	41-42					
TERMINAL NO.	43-44					
	45-46					
	47-48					
	FULL OPEN	a	INTERMEDIATE	b	FULL CLOSE	
VALVE POSITION						
— INDICATES CONTACT CLOSED						
- - - INDICATES CONTACT OPEN						

CONTACT RATING: 5A AT 250V AC & 0.5A AT 220V DC

						BHARAT HEAVY ELECTRICALS LTD. UNIT: HIGH PRESSURE BOILER PLANT. TIRUCHIRAPALLI 620014.	
				365-139			
		DRAWN		N.P.ESWAR		TITLE	
		CHECKED		K.ARUNACHALAM		INTERNAL WIRING DIAGRAM	
		APPROVED		P.LOGANATHAN		FOR	
		DATE		09.09.2000		ELECTRICAL VALVE ACTUATORS (AC)	
		CONTACT DEV. FIG.ADDED.				(DRAWN FOR INTERMEDIATE POSITION OF VALVES)	
11	09.09.2000						
REV	DATE	CHD	APPD	DESCRIPTION	DRAWING No.	4-V-MISC-90271	REV 11

RETRACED WITH REVISION 11



DATA SHEET FOR PRESSURE / DIFFERENTIAL PRESSURE TRANSMITTER

SPECIFICATION NO.:

VOLUME

SECTION

REV. NO.

DATE:

SHEET 1 OF 2

TAG No. Qty.....

Data Sheet No.: PES-145-01-DS1-0

Data Sheet A & B

DATA SHEET-A FOR PRESSURE / DIFFERENTIAL PRESSURE TRANSMITTER
(TO BE FILLED BY PURCHASER)

DATA SHEET-B
(TO BE FILLED-UP BY BIDDER)

GENERAL	MANUFACTURER	BIDDER TO SPECIFY		
	MODEL NUMBER	BIDDER TO SPECIFY		
TECHNICAL	TYPE	<input checked="" type="checkbox"/> CAPACITANCE/PIEZO ELECTRIC (Microprocessor based 2 wire type, HART protocol compatible)		
	POWER SUPPLY	24V DC		
	TRANSMITTER MEASUREMENT	<input type="checkbox"/> PRESSURE <input checked="" type="checkbox"/> DIFF. PRESSURE		
	OUTPUT SIGNAL	4-20 mA		
	NO. OF WIRE	TWO		
	ACCURACY	± 0.075% OF SPAN OR BETTER		
	LINEARITY, HYSTERISIS, DEAD BAND AND REPEATABILITY	± 0.1% OF SPAN		
	STABILITY	± 0.1% OF SPAN OR BETTER FOR 6 MONTHS FOR PRESSURE <70KG/CM2 ± 0.25% OF SPAN OR BETTER FOR 6 MONTHS FOR PRESSURE >70KG/CM2		
	SENSITIVITY	± 0.05% OF SPAN		
	<u>MATERIAL</u>			
	A) BODY	ALUMINIUM ALLOY OR BETTER		
	B) ELEMENT	316 SS		
	C) SEAL	TEFLON		
	CONTINUOUSLY ADJUSTABLE SPAN AND ZERO ADJUSTMENT PROVIDED	<input checked="" type="checkbox"/> YES <input type="checkbox"/> NO		
	MOUNTING	<input type="checkbox"/> WALL/PIPE STAND <input checked="" type="checkbox"/> TRANSMITTER RACK		
	ENCLOSURE	<input checked="" type="checkbox"/> NEMA-4X/IP 67 <input type="checkbox"/> NEMA-7		
	TURN DOWN RATIO	TO BE SPECIFIED BY BIDDER		
	INSULATION RESISTANCE	TO BE SPECIFIED BY BIDDER		
	ZERO SUPPRESSION RANGE	TO BE SPECIFIED BY BIDDER		
	ZERO ELEVATION RANGE	TO BE SPECIFIED BY BIDDER		
INTEGRAL INDICATOR	<input checked="" type="checkbox"/> YES <input type="checkbox"/> NO			

	DATA SHEET FOR PRESSURE / DIFFERENTIAL PRESSURE TRANSMITTER			SPECIFICATION NO.:	
				VOLUME	
				SECTION	
				REV. NO.	DATE:
SHEET 2 OF 2					
TAG No. Qty.....			Data Sheet No.: PES-145-01-DS1-0		
Data Sheet A & B					
DATA SHEET-A FOR PRESSURE / DIFFERENTIAL PRESSURE TRANSMITTER (TO BE FILLED BY PURCHASER)				DATA SHEET-B (TO BE FILLED-UP BY BIDDER)	
	TRANSMITTER SHALL BE ABLE TO DRIVE OUTPUT IMPEDANCE OF 500 OHMS.	YES			
	ZERO DRIFT	± 0.11% PER DEG C			
	SPAN DRIFT	± 0.015% PER DEG C			
	<u>MANIFOLD</u>				
	DIFFERENTIAL PRESSURE MEASUREMENT	5 WAY			
	CABLE ENTRY DETAIL	SUITABLE FOR DIA OF 17.5 mm			
NAME SIGNATURE DATE	PREPARED BY	CHECKED BY	APPROVED BY	COMPANY SEAL NAME SIGNATURE DATE	



**DATA SHEET FOR PRESSURE /
DIFFERENTIAL PRESSURE TRANSMITTER**

SPECIFICATION NO.:

VOLUME

SECTION

REV. NO.

DATE:

SHEET 1 OF 2

TAG No. Qty.....

Data Sheet No.: **PES-145-01-DS2-0**

Data Sheet C

DATA SHEET-C FOR PRESSURE / DIFFERENTIAL PRESSURE TRANSMITTER
(TO BE FILLED BY CONTRACTOR AFTER AWARD OF CONTRACT)

GENERAL	MANUFACTURER	
	MODEL NUMBER	
TECHNICAL	TYPE	
	POWER SUPPLY	
	TRANSMITTER MEASUREMENT	
	OUTPUT SIGNAL	
	NO. OF WIRE	
	ACCURACY	
	LINEARITY, HYSTERISIS, DEAD BAND AND REPEATABILITY	
	STABILITY	
	SENSITIVITY	
	<u>MATERIAL</u>	
	A) BODY	
	B) ELEMENT	
	C) SEAL	
	CONTINUOUSLY ADJUSTABLE SPAN AND ZERO ADJUSTMENT PROVIDED	
	MOUNTING	
	ENCLOSURE	
	TURN DOWN RATIO	
INSULATION RESISTANCE		
ZERO SUPPRESSION RANGE		
ZERO ELEVATION RANGE		
INTEGRAL INDICATOR		



**DATA SHEET FOR PRESSURE /
DIFFERENTIAL PRESSURE TRANSMITTER**

SPECIFICATION NO.:	
VOLUME	
SECTION	
REV. NO.	DATE:
SHEET 2	OF 2

TAG No. Qty.....

Data Sheet No.: **PES-145-01-DS2-0**

Data Sheet C

DATA SHEET-C FOR PRESSURE / DIFFERENTIAL PRESSURE TRANSMITTER
(TO BE FILLED BY CONTRACTOR AFTER AWARD OF CONTRACT)

	TRANSMITTER SHALL BE ABLE TO DRIVE OUTPUT IMPEDANCE OF 500 OHMS.			
	ZERO DRIFT			
	SPAN DRIFT			
	<u>MANIFOLD</u>			
	a) PRESSURE MEASUREMENT			
	B) DIFFERENTIAL PRESSURE MEASUREMENT			
	CABLE ENTRY DETAIL			
NAME SIGNATURE DATE	PREPARED BY	CHECKED BY	APPROVED BY	COMPANY SEAL NAME SIGNATURE DATE

9.2 Pressure / Differential Pressure / Flow / Level Transmitter
Table 9.1
Specifications for Pressure / Differential Pressure / Flow / Level Transmitter

S.N	Features	Minimum Requirements
1	Type	Microprocessor based 2 wire type, HART protocol compatible
2	Sensor Type	Capacitive/ Piezo-electric
3	Output Signal	4-20 mA signals superimposed with HART signal.
4	Signal Processing Unit	Microprocessor based
5	Overpressure	150% of max. operating pressure. For vacuum service, the element shall have under – range protection to full vacuum
6	Turn-down Ratio	10:1 for vacuum / very low pressure applications. 100:1 for other applications.
7	Stability	± 0.1% of calibrated span for six months up to 70 Kg/cm ² and ± 0.25% for range more than 70 Kg/cm ² (g).
8	Span and Zero drift	± 0.015% per deg. C at max span & 0.11% per deg. C at min. span.
9	Enclosure Class	Weather proof as per IP 67 with corrosion resistance coating. For hazardous area explosion proof enclosure as described in NEC article 500
10	Zero & span adjustability	Continuous, tamper proof, remote as well as manual from instrument with zero suppression and elevation facility.
11	Local Indicator	To be provided
12	Display	Digital LCD Integral Display (minimum 5 digit) Engineering Unit
13	Process connection	½" NPT (F)
14	Electrical connection	½" NPT
15	MOC of Electrical Housing	Aluminum Alloy or better
16	Ambient Temperature	65 Deg. C
17	Operating Voltage	16 – 48 Volts DC
18	Load	600 Ohms (minimum) at 24 Volts DC
19	Accuracy	± 0.075% of span or better
20	Response Time	100 milli-second or better
21	Adjustment/ calibration/ maintenance	Centralised PC based system maintenance per clause.

- All transmitters shall be equipped with all necessary accessories like valve manifolds, mounting bracket etc. Pulsation dampeners shall be used where the process media is unstable for measurement such as at the discharge of a pump. For absolute pressure transmitter, 2 valve manifold; for gauge / vacuum pressure transmitter, 3 valve manifold and



- for DP / level / flow transmitter, 5 valve manifold shall be provided. In case if it becomes necessary to use a DP transmitter for pressure measurement then a 3 valve manifold shall be used in place of 2 valve manifold.
2. Pressure transmitter shall have easily accessible span, zero and time constant adjustments. A range suppression / elevation device shall be provided wherever required.
 3. For pressure / differential pressure transmitter, proof pressure shall be 200% of maximum static process pressure.
 4. All transmitter cases shall be dust – tight and rugged. Weather – proof and explosion – proof cases shall be used in outdoor and hazardous areas respectively. Protection clause shall be of IP 67 or better.
 5. Transmitters for pressure / DP measurements of liquid and steam shall always be installed below the sampling point, preferably with the connection at the top.
 6. Transmitters for pressure / DP measurements for gases and air shall always be installed above the sampling point, preferably with the connection at the bottom.
 7. Transmitters with diaphragm seal system shall be considered when
 - The process temperature is outside of the normal operating ranges of the transmitter and cannot be brought into those limits with impulse piping or
 - The process is corrosive and would require frequent transmitter replacement or unusual materials of construction or
 - The process contains suspended solids or is viscous and may plug the impulse piping or
 - There is a need to make density or interface measurements or
 - The process medium may freeze or solidify in transmitter or impulse piping.
 8. Diaphragm seal shall be either capillary type or direct mounted type depending upon the application. Parts below the diaphragm shall be removable for cleaning. The entire volume above the diaphragm shall be completely filled with an inert liquid suitable for the application.
 9. Differential pressure type level transmitters shall be used for range above 1219 mm, for services requiring purge or where liquid might boil in external portions.
 10. Differential pressure type level transmitters for use on corrosive service shall generally be diaphragm wafer with extended filled capillary type. Flush or extended diaphragm type DP transmitter shall be considered for special application. Diaphragm material shall normally be stainless steel or any other special alloy.



11. Differential pressure type flow transmitters shall have in-built square-root extractors.

9.3 Temperature Transmitter

Table 9.2

Specifications for Temperature Transmitter

S.N	Features	Minimum Requirements
1	Type	2-Wire, Smart (HART)
2	Output Signal	4-20 mA signals superimposed with HART signal.
3	Signal Processing Unit	Microprocessor based
4	Accuracy	± 0.075 % of span or better
5	Local Indicator	To be provided
6	Display	Digital LCD Integral Display (minimum 5 digit) Engineering Unit
7	Input	Ohm input from Pt-100 RTD/ mV signal from thermocouples
8	Stability	± 0.1 % of reading or 0.1°C, whichever is greater, for 24 months for RTDs. ± 0.1 % of reading or 0.1 °C, whichever is greater, for 12 months for thermocouples
9	Output	4-20 mA DC, linear
10	Load	600 Ohms (minimum) at 24 Volts DC
11	Power Supply	24 VDC, 2- Wire Loop Power
12	MOC of Electrical Housing	Aluminum Alloy or better
13	Enclosure Class	Weather proof as per IP 67 with corrosion resistance coating. For hazardous area explosion proof enclosure as described in NEC article 500

1. The temperature transmitter of following types (2-wire Loop Powered temperature transmitter) compatible with thermocouples and RTDs shall be provided. Cold junction temperature compensation of the thermocouples shall be performed in the temperature transmitter itself.

a. Single Input DIN-rail mounted Temperature Transmitter

These shall be suitable for mounting on DIN-rails in Panels/JBs in air conditioned room. This temperature transmitter shall be the ones which are especially designed for DIN-rail mounting with IP 20 protection class. These shall have terminals for input/output provided on front side when mounted on DIN-rail. Head mounted temperature transmitter with clamps to make it suitable for DIN-rail mounting shall not be acceptable under this category.

	CHECK LIST FOR PRESSURE / DIFFERENTIAL PRESSURE TRANSMITTER (Mechanical Auxiliary Packages)	SPECIFICATION NO.:	
		VOLUME	
		SECTION	
		REV. NO.	DATE:
		SHEET 1 OF 1	
Data Sheet No.: PE-CL-999-145-1026-0			

SL NO	TESTS/CHECKS	QUANTM OF CHECK	REFERENCE DOC. ACCEPTANCE NORMS	AGENCY			REMARKS
				M	C	B	
1.0	CHECKS FOR VISULA, MODEL TAG NO.	SEE NOTE-1 BELOW	APPROVED TECHINCAL REQUIREMENT/ DATA SHEET	P	W	V	MFR TO CARRY OUT ROUTINE TEST ON 100%. WHEN MATERIAL CORELATION ARE NOT AVAILABLE MFR'S COMPLIANCE TO BE PROVIDED
2.0	PROCESS CONNECTION	-do-		P	W	V	
3.0	ACCURACY	-do-		P	W	V	
4.0	REPEATEABILITY	-do-		P	W	V	
5.0	HYSTERISIS	-do-		P	W	V	
6.0	EFFECT OF TEMP VARIATION ON ACCURACY	-do-		P	W	V	
7.0	SPAN /ZERO ADJUSTMENT	ONE/TYPE		P	W	V	
8.0	EFFECT OF SUPPLY VOLTAGE VARIATION	ONE/TYPE		P	W	V	
9.0	HIGH PRESSURE TEST	SEE NOTE-1 BELOW		P	W	V	
10.0	BURN IN TEST	ONE/TYPE		P	W	V	
11.0	DEGREE OF PROTECTION	ONE/TYPE		P	W	V	

LEGEND:

M: MANUFACTURER/ SUB CONTRACTOR, C: CONTRACTOR/ NOMINATED INSP AGENCY, B: BHEL. P: PERFORM, W: WITNESS, V: VERIFICATION.

NOTE:

- QUANTUM OF CHECK SHALL BE AS BELOW
100 % - BY MANUFACTURER
RANDOM FOR EACH TYPE – BY BHEL & CUSTOMER
- MANUFACTURER TO MAINTAIN CALIBRATED INSTRUMENT HAVING BETTER ACCURACY THAN THE ITEM UNDER TEST. INSPECTING ENGINEER SHALL CHECK THE SAME.
- IN CASE OF IMPORTED ITEMS CONTRACTORS SHALL REVIEW TC's AND NOT INSPECT.

CONTRACTOR TO PROVIDE COMPLIANCE CERTIFICATE FOR TESTS/CHECKS VERIFIED BY CONTRACTOR AND SUBMIT THE SAME ALONGWITH TEST CERTIFICATES TO BE VERIFIED BY BHEL.



**DATA SHEET FOR
PRESSURE / DIFFERENTIAL PRESSURE GAUGE**

SPECIFICATION NO.:	
VOLUME	
SECTION	
REV. NO.	DATE:
SHEET 1	OF 1

TAG No. Qty.....

Data Sheet No.: **PE-DC-999-145-I026**

Data Sheet A & B

DATA SHEET-A FOR PRESSURE / DIFFERENTIAL PRESSURE GAUGE
(TO BE FILLED BY PURCHASER)

DATA SHEET-B
(TO BE FILLED-UP BY BIDDER)

GENERAL	MANUFACTURER		
	MODEL NUMBER		
TECHNICAL	PRESSURE ELEMENT	<input checked="" type="checkbox"/> BOURDON <input type="checkbox"/> DIAPHRAGM <input type="checkbox"/> BELLOW	
	MATERIAL	SENSING ELEMENT – AISI 316 SS MOVEMENT – AISI 304 SS CASING – <input type="checkbox"/> DIE CAST AL <input checked="" type="checkbox"/> SS	
	ENCLOSURE	<input type="checkbox"/> INDOOR MOUNTED IP-55 <input checked="" type="checkbox"/> OUTDOOR MOUNTED IP-65 <input type="checkbox"/> FUEL GAS HAZARDOUS APPL. EXPL. PROOF	
	DIAL	SIZE: <input type="checkbox"/> 100MM <input checked="" type="checkbox"/> 150MM COLOR: WHITE NUMERALS: BLACK SCALE: <input checked="" type="checkbox"/> LINEAR <input type="checkbox"/> SQUARE ROOT	
	CASE	COLOUR : BLACK	
	ADJUSTMENT	<input checked="" type="checkbox"/> EXT. MICROMETER SCREW <input type="checkbox"/> INT. MICRO SCREW	
	MOUNTING	<input checked="" type="checkbox"/> LOCAL <input type="checkbox"/> PANEL OR RACK	
	OVER RANGE PROTECTION	150% OF FSD	
	BLOW OUT DISC	SUITABLE MATERIAL	
	SWITCHING FACILITY TYPE NO. / TYPE OF CONTACTS CONTACT RATING SETTING RANGE REPEATABILITY POWER SUPPLY	<input type="checkbox"/> YES <input checked="" type="checkbox"/> NO <input type="checkbox"/> MICRO SWITCH <input type="checkbox"/> OTHER 2 NOS. SPDT 5A 230V AC, 0.25A 220V DC FIELD ADJUSTABLE OVER FULL RANGE $\pm 1\%$ OF FSR 230V AC (if required)	
PERFORMANCE	ACCURACY	$\pm 1\%$ OR BETTER OF FULL SCALE DEFLECTION	
CONNECTION	PROCESS	1/2 " NPT(M)	
	LOCATION	<input type="checkbox"/> BACK <input checked="" type="checkbox"/> BOTTOM	
ACCESSORIES	NAME PLATE / METAL TAG	SS	
	MOUNTING	<input type="checkbox"/> WALL <input checked="" type="checkbox"/> PIPE – U CLAMPS & BOLTS <input type="checkbox"/> PANEL / RACK	
	OTHER	AS PER ENCLOSED DIAGRAM OR CUSTOMER SPECIFICATION	
NAME			NAME
SIGNATURE			SIGNATURE
DATE			DATE



**DATA SHEET FOR
PRESSURE / DIFFERENTIAL PRESSURE GAUGE**

SPECIFICATION NO.:	
VOLUME	
SECTION	
REV. NO.	DATE:
SHEET 1	OF 1

TAG No. Qty.....

Data Sheet No.: **PE-DC-999-145-1026**

Data Sheet C

DATA SHEET-C FOR PRESSURE / DIFFERENTIAL PRESSURE GAUGE
(TO BE FILLED BY CONTRACTOR AFTER AWARD OF CONTRACT)

GENERAL	MANUFACTURER		
	MODEL NUMBER		
TECHNICAL	PRESSURE ELEMENT		
	MATERIAL		
	ENCLOSURE		
	DIAL		
	CASE		
	ADJUSTMENT		
	MOUNTING		
	OVER RANGE PROTECTION		
	BLOW OUT DISC		
	SWITCHING FACILITY TYPE NO. / TYPE OF CONTACTS CONTACT RATING SETTING RANGE REPEATABILITY POWER SUPPLY		
PERFORMANCE	ACCURACY		
CONNECTION	PROCESS		
	LOCATION		
ACCESSORIES	NAME PLATE / METAL TAG		
	MOUNTING		
	OTHER		
NAME			NAME
SIGNATURE			SIGNATURE
DATE			DATE



2. Thermo wells shall, in general, be of SS 316 and shall be drilled from bar stock except for air and flue gas services. However, selection of thermo well material shall be as per following guideline.
3. Welded type thermo wells with 38 mm O.D. for welding & ½" NPT internal threads shall be used for pressure above 100 kg / sq cm or temperature above 400 deg C. Socket weld type thermo well with 34 mm O.D. for welding & ½" NPT internal thread, shall be used for pressure between 40-100 kg/cm² and temperature up to 400°C. Screwed type thermo wells with ½" NPT internal threads & M33X2 (M) outer threads shall be used for pressure below 40 kg/cm² and temperature below 400°C. For pipes having probability of prolonged vibration, seal welding may be done all around after tightening the thermo well within the base.
4. Thermo well manufacturing drawing covering material specification, dimensional details, details of special treatment, finish etc. as well as test procedure shall be subject to Owner's / Consultant's approval. Material certificate shall have to be furnished for each thermo well.
5. Wherever any approval is necessary from any recognized body / authority during manufacturing of high pressure wells, the same shall have to be arranged by the Contractor.
6. The thermo well immersion depth (U) shall be sufficient to eliminate conduction error. A general rule which may be followed is to use an immersion length equalling a minimum of 10 times the diameter of the protective tube or well. In general, immersion length of thermo wells for different line sizes shall be as follows:

Table 9.5

Thermowell Immersion Length

S.N	Line Size	Immersion Length
1	From 4" to 6"	65 mm
2	From 8" & onwards	140 mm
3	Vessels	400 mm

9.7 Pressure Gauge/ Differential Pressure Gauge/Draft Gauge

Table 9.6

Specification for Pressure Gauge/ DP Gauge/ Draft Gauge

S.N	Feature	Minimum Requirement
1	Type	Bourdon / Bellows / Diaphragm
2	Sensing Element Material	AISI 316 SS
3	Movement Material	AISI 304 SS



S.N	Feature	Minimum Requirement
4	Case Material / Protection Class	SS / IP 65
5	Dial Size	150 mm For Special application 250 mm shall be used
6	Scale	Black lettering on white background in 270 °C arc
7	Range Selection	Normally operate at 75% of its maximum pressure range. Instruments measuring varying pressures shall operate in a band of 60% of its maximum pressure range.
8	Over range Protection	150% of maximum range by internal stop. External stop below zero.
9	Adjustment	External Micrometer screw for zero adjustment. Internal micrometer screw for range adjustment.
10	Stop at Max. Reading	Shall be provided
11	Element Connection	Argon welding
12	Process Connection	½" NPT(M) bottom connection for local mounting, back connection for panel mounting
13	Accuracy	+/- 1.0 % of full scale or better
14	Operating Ambient Temperature	50 °C (Max. continuous)
15	Safety Feature	Neoprene Safety Diaphragm (Blowout disc) at the back
16	Window	Shatter-proof glass
17	Chemical Seal Unit	SS 316 Flange and Diaphragm, PTFE coated / block, Silicon Oil filling fluid
18	Accessories	Snubbers for pulsating fluid applications / 3-way gauge cock / 2-valve manifold / Pigtail / Siphon for steam service / Gauge Saver, if maximum or Design Pressure is very high than the Operating Pressure / Counter Flanges / Bolts, Nuts, Gaskets / SS Tag Plate

1. Directly connected pressure measuring instruments shall be diaphragm, bourdon or bellow type elements depending upon the services conditions. In general, diaphragm elements shall be used in the range of 0 to 1000 mm water column pressure, bellow type element for ranges of 0 to 1 Kg/cm² and bourdon type element for ranges greater than 1 Kg/cm².
2. Primary element material shall be corrosion resistant to process fluid or diaphragm seals shall be provided for protection.
3. For draft measurement Teflon coated beryllium copper diaphragm shall be used.



4. Snubbers shall be floating pin type, externally mounted and externally adjustable. It shall be used for all pulsating services.
5. Diaphragm seals, filled type or mechanical type shall be furnished where plugging of the element may occur or where suitable material is not available in highly corrosive services. When chemical seals are required, they shall be the clean out type with flushing connection.
6. Over-range protection shall be provided to at least 150 % of range. For vacuum service, the element shall have under-range protection to full vacuum
7. Ranges of the gauges shall be so selected that the gauge normally operates in the middle third of the scale and conform to IS 3624 standard dials, wherever necessary.
8. The sensing elements for all gauges shall be properly aged and factory tested to remove all residual stresses and shall be SS 316 with forged socket and tip of the same material. Elements above 70 Kg/sq. cm range shall be bored instead of drawn.
9. For low pressure application where long elements are used, well supported protecting tube shall be installed to prevent mechanical damage and erosion of the elements.

9.8 Temperature Gauge

**Table 9.7
Specification for Temperature Gauge**

S.N	Feature	Minimum Requirement
1	Type	Mercury filled
2	Sensing Element material	Bourdon AISI 316 SS
3	Movement Materials	AISI 304 SS
4	Case Material/Protection class	SS / IP65
5	Capillary Armouring	SS Flexible
6	Capillary	SS 316 (5 mtr. Length for Local & 15 metre for panel Mounting)
7	Bulb/Stem Diameter	12 mm
8	Dial Size	150 mm
9	Window	Shatterproof glass
10	Scale	Black lettering on white background in 270 °C arc
11	Adjustment	Micrometer screw for zero adjustment. Internal micrometer screw for range adjustment.
12	Pointer	Externally Adjustable
13	Range Selection	Normal Process Temperature –



**CHECK LIST FOR
PRESSURE / DIFFERENTIAL PRESSURE GAUGE
(MECHANICAL AUXILIARY PACKAGES)**

SPECIFICATION NO.: PE-TS-394-145-I054
VOLUME
SECTION
REV. NO. 00 DATE: 27.09.2013
SHEET 13 OF 19

SL NO	TESTS/CHECKS	QUANTM OF CHECK	REFERENCE DOC. ACCEPTANCE NORMS	AGENCY			REMARKS
				P	W	V	
1.0	CHECK FOR		APPROVED TECHINCAL REQUIREMENT/ DATA SHEET				MFR TO CARRY OUT ROUTINE TEST ON 100%. WHEN MATL CORELATION ARE NOT AVAILABLE MFR'S COMPLIANCE TO BE PROVIDED
	1.1 DIAL SIZE	100%		M	C	C	
	1.2 MODEL NO/TAG NO	100%		M	C	C	
	1.3 RANGE/SCALE	100%		M	C	C	
	1.4 END CONNECTION	100%		M	C	C	
	1.5 SWITCH CONTACT RATING & NOS	100%		M	C	C	
2.0	CALIBRATION						
	2.1 ACCURACY	100%		M	C	B	
	2.2 REPEATABILITY (FOR SWITCH)	100%		M	C	B	
	2.3 SET POINT ADJUSTMENT FOR SWITCH	100%		M	C	C	
3.0	OVER PRESSURE & LEAK TEST	100%		M	C	C	
4.0	OPERATION OF PR. RELEIF DEVICE	ONE PER TYPE		M	C	C	
5.0	REVIEW OF T.C. FOR MATERIAL OF--						
	5.1 SENSOR	FOR LOT	-	-	B		
	5.2 MOVEMENT		-	-	B		
	5.3 PROCESS CONNECTION		-	-	B		
	5.4 HOUSING		-	-	B		
6.0	REVIEW OF T.C. FOR DEGREE OF PROTECTION	TYPE TEST	-	-	B		
7.0	REVIEW OF T.C. FOR CONTACT RATING OF SWITCH	ONE PER TYPE	-	-	B		
8.0	ACCESSORIES AS APPLICABLE	100%	M	C	C		

LEGEND:

M: MANUFACTURER/ SUB CONTRACTOR, C: CONTRACTOR/ NOMINATED INSP AGENCY, B: BHEL. P: PERFORM, W: WITNESS, V: VERIFICATION.

NOTE:

CONTRACTOR TO PROVIDE COMPLIANCE CERTIFICATE FOR TESTS/CHECKS VERIFIED BY CONTRACTOR AND SUBMIT THE SAME ALONGWITH TEST CERTIFICATES TO BE VERIFIED BY BHEL.



8. PROGRAMMABLE LOGIC CONTROLLER (PLC)

This section covers the minimum specification for the PLC for TG auxiliaries as specified in clause 7.9 & for the offsite packages such as Emergency DG System & HVAC system.

8.1 General Technical & Design Requirements

1. Programmable Logic Controller (PLC) shall be microprocessor-based system. The PLC shall be versatile, expandable, user friendly and latest state of art technology. The system shall be envisaged for the purpose of sequential operation, protection and interlock, data acquisition system, alarm functions, closed loop control and data archiving for fully automatic operation. Logic controller shall be provided with adequate and reliable protection safeguard for various equipments and to assist the operator for easy safe and efficient starting and stopping of various drives in the process. The system shall be designed by selecting high-grade components of proven quality and proper design of system electronics. The system shall be able to operate satisfactorily with reference to the specified environmental conditions as indicated in the specification.
2. The system shall be modular in construction and expandable in future by adding additional electronic modules, which shall be easily accessible for maintenance and repair. The modules shall preferably be Rack/Rail mounted. The types of modules shall be kept to minimum possible in order to have interchangeability and spares inventory.
3. The system shall have extensive self-diagnostic hardware and software features for easy and fast maintenance of the PLC. Safety barriers shall be provided for intrinsically safe input / output circuits.
4. The PLC shall have very high noise immunity in order to ensure safe and reliable operation when subjected to electrical radio frequency interference and electromagnetic disturbances expected in a power plant.
5. The system shall be programmed as per the logic requirements required for the functioning of the systems and equipment. Contractor shall prepare their own logic / ladder diagrams depending upon the capability of the programmable logic controller offered by them.
6. Operation of the PLC shall be completely unaffected by a momentary power loss of the order of 20 milliseconds.
7. On-line replacement of any module shall be possible in such a way that the removal and addition of the module shall be possible without de-energizing the system or causing any interruption in the system while replacing a faulty module except for the inputs /outputs which are being handled by that module. However, in case of triple modular



redundant or dual PLC configurations, there shall not be any process upset while replacement.

8. PLC shall be provided with 20% hard wired installed spares and 20% I/O channels.
9. The system shall be capable of handling the long-term storage of data for 15 days and retrieval.
10. The system shall be provided with programming and diagnostic facility. Each PLC shall be provided with one no. Laptop of latest configuration with programming software & communication cable.

8.2 PLC System Configuration

PLC shall consist of following sub systems:

8.2.1 Input/Output Sub system

1. I/O subsystem shall be suitable for accepting discrete inputs, BCD inputs and analog inputs. The I/O modules shall be mounted in the I/O racks.
2. Each I/O shall be electrically isolated from external control circuit by suitable means. The minimum isolation level between I/O and logic circuit shall be 500 V DC.
3. Each module shall have LED for each digital I/O channel to indicate the status of each input / output. Redundancy in I/O level shall be maintained as per the process requirement.
4. PLC inputs shall be provided with potential free dry contacts. All the inputs shall be double ended i.e., two wires per input and not common return for all inputs. The contact interrogation voltage for input contacts shall be 24V DC minimum. Each input channel shall be protected by separate fuse.
5. Output contacts from the PLC shall be potential free dry contacts. Each output shall be short-circuit proof and protected by fuse.
6. Visual indication of fuse blown must be provided for each input and output channel and should be alarmed
7. There shall be at least 20% spare capacity available on input & output modules, over and above the system requirement.
8. All input/output cards shall have quick disconnect terminations allowing for card replacement without disconnection of external wiring and without switching of power supply.
9. The Contractor shall provide the following monitoring features:
 - Power supply monitoring.



- Contact bounce filtering.
 - Optical isolation between input and output signals with the internal circuits.
 - In case of power supply failure or hardware fault, the critical outputs shall be automatically switched to the fail-safe mode. The fail-safe mode shall be intimated to the successful Contractor during detailed engineering.
10. Further, keying-in of individual wire connectors shall be provided to ensure that only the correct card is plugged on the I/O module. It shall be possible to remove I/O module without disconnecting wiring from field inputs or outputs.

8.2.2 Processor Sub system

1. The processor sub system shall include CPU, memory, power supply, communication interface etc.
2. Dedicated PLC's shall be envisaged for each Auxiliary system. The processor shall have capability to implement all the control functions required. The processor shall have sufficient memory for storage of the program instructions as applicable to the logic requirements. CPU shall be of 32/64 bit or upgraded version of microprocessor.
3. Memory shall be non-volatile, preferably EEPROM type. However, in case volatile memory is provided, battery back up shall be provided for a minimum of three months to keep the stored program intact. A battery drain indication shall be provided at least one week before the battery gets drained. Memory shall be provided with adequate capacity with 40% spare capacity under worst loading condition.
4. The healthiness of processor hardware and software shall be continuously monitored by watchdog timer.
5. PLC's shall be provided as a minimum with dual redundant processor subsystem including CPU, memory and power supply. Redundancy shall be provided such that, in case of failure of the main processor, the standby processor shall take over automatically and vice - versa. The changeover shall be bumpless and shall not result any process or system upset.
6. In case of failure of complete processor system i.e., both processors, outputs shall take fail safe state automatically.
7. The scan time of programmable controller shall be of the order of 100 milliseconds or better. Scan time of PLC is defined as the cycle time taken by the system to read input, process input executing logic and update control output for all the logics configured within the system. Other activities like diagnostic routines, output / dump of data to



peripherals, or any other activity which consume processor time shall also be accounted while computing scan time.

8.2.3 Communication Sub system

1. The communication subsystem shall provide reliable and high speed data transfer between the processor subsystem, I/O subsystem, PLC console and other devices connected to the system.
2. Redundancy in communication subsystem shall be provided, such that on the failure of the active device, communication link or bus, the redundant device communication link or bus shall take-over automatically without interrupting the system operation. The communication bus shall be of coaxial / Fibre optic type.
3. Information about the failed device shall be displayed locally as well as on the PLC console. It shall be possible to manually switch-over the communication from main bus device to redundant bus device without interrupting the PLC functions.
4. The offered PLC shall have provisions of communication interface facility with Plant DCS system in order to make the entire system operational from CCR. Bi-directional, Redundant OPC links shall be provided in the PLC for the connectivity with the Plant DCS. All the required redundant Fibre Optic Cable Interface Modules on PLC side are included in the Contractor's scope.
5. Following are also in the scope of supply & work of the Contractor:
 - Cables required for interfacing with Plant DCS.
 - Implementation of Tags and establishing the Link.
 - Any other software/hardware required.

8.3 System Power Supply

1. For PLC system, redundant 24 V DC power supply shall be provided by the Contractor. The required power supply cable shall be provided by Contractor from the UPS DCDB & ACDB as explained in clause 6.2.14 for TG integral control system
2. For separately mounted I/O racks, separate power supplies shall be provided. Power supply module shall be of ample capacity to supply all modules. In addition 20% spare capacity for future shall be provided. All the drives shall be switched ON/OFF through 24V DC coupling relays to be provided in HT/LT SWGR panels. The exact power supply scheme shall be as approved by Owner during detailed Engineering stage.
3. For the Operator Stations and Engineering Station the power supply shall be from the 220 V, AC, UPS system.



8.4 PLC Console

1. PLC Console or operating panel/display panel shall be provided as operator Interface station for control and monitoring of the plant. This shall be done through dynamic mimic displays and control displays.
2. PLC console shall also be used for program storage, display, fault diagnostic and alarm monitoring. It shall be possible to modify, add or delete the application program on-line without affecting the outputs. It should be possible to modify or create new displays from PLC Console.
3. Isolation shall be provided between programming terminal and related subsystems, if there is any possibility of high voltage from TFT being transmitted to other subsystems.
4. The offered PLC system shall have provision to shift the Operator Station/Engineering Station to the CCR in future with third party interactive communication facility.

8.5 Displays

The system shall be capable of reading the status of equipments, acquiring the analog signals, displaying the status in the form of mimic diagram, video trend, bar graph, periodic display, alarm display, alarm overview display, logs such as hourly/shift/daily logs, alarm logs etc.

Displays include plant mimic diagrams, which shall include the complete auxiliary plant system indicating each major components of the system and the operating status of individual equipment and devices

8.6 Alarms

1. The system shall display history of alarms in chronological order of occurrence on the Operator Station TFT. At least three (3) levels of alarm priority shall be available which shall be displayed in different color. It should be possible to display and print alarms. System shall have all alarm related functional keys like acknowledge, reset etc. Other design features like set point / dead band adjustment, alarm priority, manual and automatic inhibition based on predefined logic etc. shall be provided, which shall be as finalized during detail engineering.
2. The alarm display shall be built bottom up with the most recent alarm at the top of the list. When a point returns to normal, the associated alarm line shall change color suitably and on acknowledgement, the line shall be blanked out.
3. The alarms below the blank lines shall move upward to fill the empty lines. If the capacity of the OWS display page is exceeded, alarm



history shall be stored in memory to accept the over- flow. This alarm history shall be displayed upon operator demand. The format and details of alarm displays shall be finalized during detail engineering.

4. When a point goes into an alarm state and appears on the alarm screen, the time of alarm will flash until acknowledged by the operator. Acknowledgement by the operator will cause the time to stop flashing. All alarm initiations and return to normal, shall be logged on a printer.

8.7 System Software

1. Complete licensed software for PLC based system including the communication software system shall be supplied and implemented to meet completely the specification requirements.
2. Application software shall be built based on approved logic diagram, graphics etc and shall include controls, graphics, logs, trends, historization, report generation etc.
3. The system software shall include all programs for the PLC and PLC console which are required to perform all the PLC functions including communication and self-diagnostics.
4. Diagnostic software shall have the capability to provide information about the failed module / system either in the form of a system configuration display or provide information in the form of a statement.
5. The Contractor shall provide software license for all the software provided for the project. The software's shall not be machine specific. All software licenses shall be valid for the continuous service life of the plant and equipment.
6. Password security shall be provided in order to ensure security level to the plant operation.

8.8 Peripherals

1. All peripherals shall conform to the minimum requirements indicated in the specification, the exact make and model number shall be as approved by the Owner/consultant during detailed engineering stage.
2. VDU/ TFT shall be multi-sync, 21" colour monitor with intelligent terminal and key board. TFT shall be provided with graphic and mimic capabilities with minimum 64 distinct colors. The graphic resolution shall be 600x 1280 dots minimum with 0.25 mm dot pixel and refresh rate shall be 85 Hz or better.
3. Suitable optical filter for minimum secondary glare shall be provided.
4. The color laser printer shall be automatic duplex printing type suitable for printing A4 size paper. Printing speed shall be minimum 6 ppm for



color and 24 ppm for black and white. The printer shall be heavy-duty type with minimum 50,000 pages/month printing capability, 600 dpi resolution, 128 MB memory and 3000 sheet input capability.

8.9 Inspection & Testing

The Contractor shall furnish the complete FAT procedure to Owner/consultant for approval during detail engineering and shall inform Owner the schedule of FAT to enable Owner/Consultant to witness the same. The following tests shall be performed as a minimum:

1. System pre-test: This shall be of physical check of all modules, racks, cabinets etc.
2. System power-up test: This shall test functionally all hardware and software.
3. Functional testing which shall include the following as a minimum
 - Complete system configuration function check and loading.
 - Demonstration of all PLC system functions.
 - 100% checking of logics configured in the PLC.
 - Checking of scan time.
 - Checking of all PLC console functions and operation in association with peripherals.
 - System redundancy checks including correct changeover of the back up unit in case of failure of main unit and vice versa.
 - System diagnostic checking for all subsystems, including checking of the testing software for I/O modules signal conditioning modules, CPU, Memory etc.
 - Checking of output status on processor failure.
 - Simulation of power failure and system restart.
 - Auto boot up of system configuration and program after power restoration.

The PLC system shall be tested at site after installation and commissioning with all inputs and output connected. All the tests conducted during FAT shall be carried out during site testing.

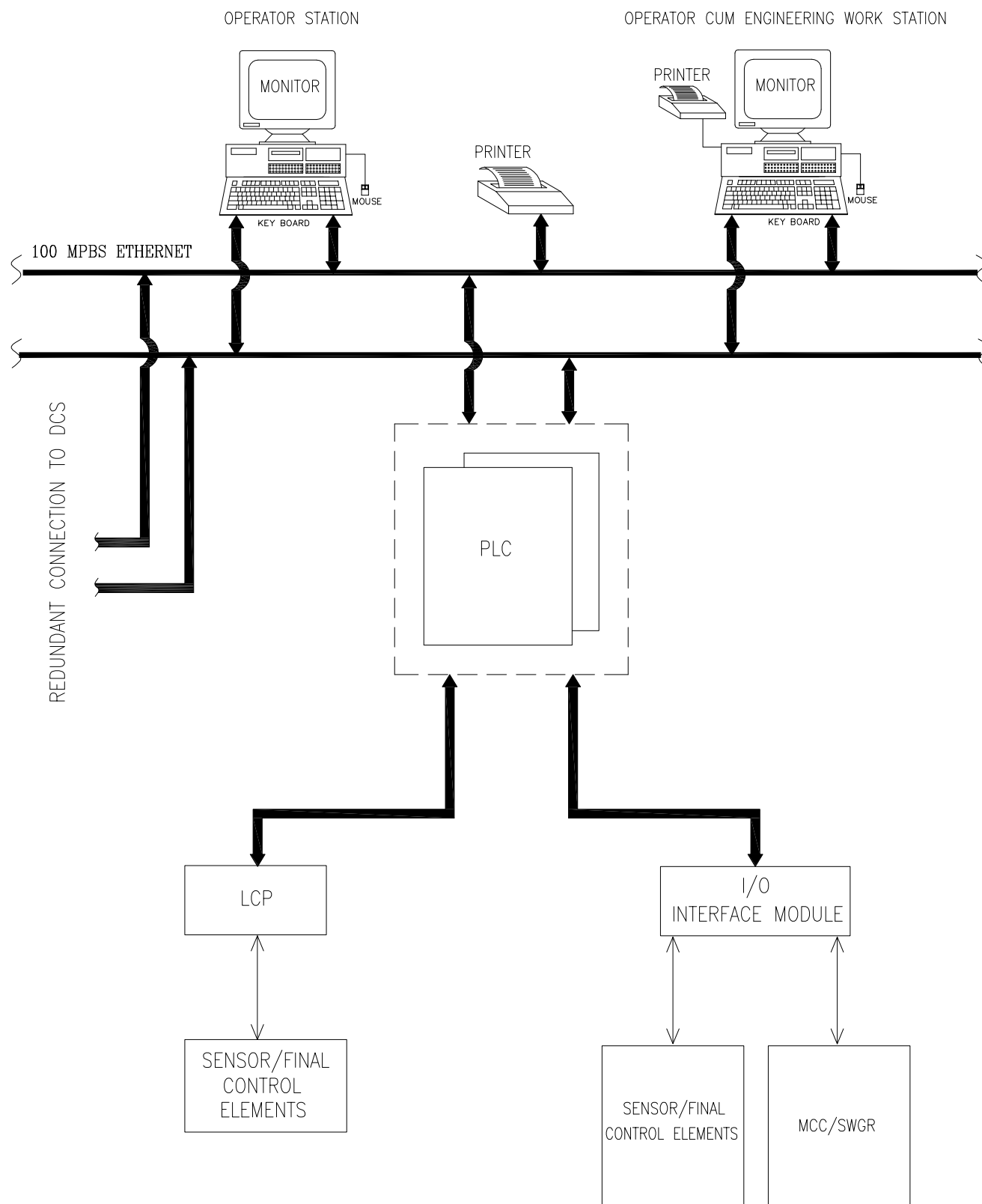

NOTES:-

1. PLC SYSTEM SHALL BE PROVIDED WITH DUAL REDUNDANT POWER SUPPLY, CPU & COMMUNICATION.
2. PLC SYSTEM SHALL BE INTERFACED WITH DCS FOR MONITORING FROM CCR THROUGH REDUNDANT OPC LINK BY FIBER OPTIC CABLE.

ABBREVIATION:-

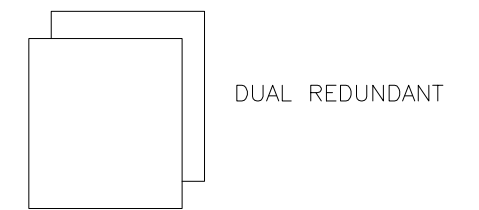

- DCS DISTRIBUTED CONTROL SYSTEM
 I/O INPUT/ OUTPUT
 PLC PROGRAMMABLE LOGIC CONTROLLER
 MCC MOTOR CONTROL CENTER
 SWGR SWITCHGEAR

FOR REFERENCE ONLY

02	25.06.11				AJV	
01	27.05.11				AJV	
00	06.05.11				AJV	
REV. No.	DATE	DEM	DEC	DEE	DEI	DESCRIPTION
		CHECKED				

 **NEYVELI LIGNITE CORPORATION LTD, NEYVELI, TAMILNADU**

 **LAHMEYER INTERNATIONAL INDIA** LAHMEYER INTERNATIONAL (INDIA) PVT. LTD. CONSULTING ENGINEERS, GURGAON, INDIA

CONTRACT NO :			PROJECT :			
PREPARED	NAME	DATE	2 X 500 MW NEYVELI NEW THERMAL POWER STATION			
DRAWN BY	PS	06-MAY-11	DRAWING TITLE :			
DESIGNED BY	SM	06-MAY-11	TYPICAL PLC BASED CONTROL SYSTEM CONFIGURATION BLOCK DIAGRAM			
CHECKED BY	AJV	06-MAY-11	DRAWING NO :			
APPROVED BY	UJR	06-MAY-11	LII-GEOE11019-G-00172-325			
SHEET SIZE	A3		REV.	SHEET		
SCALE	NTS		02	1 OF 1		

Protection mark DIN 34 - 1 - E: Copying of this drawing, and giving it to others and the use or communication of the contents thereof, are forbidden without express authority. Offenders are liable to the payment of damages. All rights are reserved in the event of the grant of a patent or the registration of a utility model or design.



TITLE :-

UPS SCHEME

SPECIFICATION NO. PE-SS-999-145-1035

VOLUME II B

SECTION D

REV. NO. 00

DATE

SHT 11

OF

11

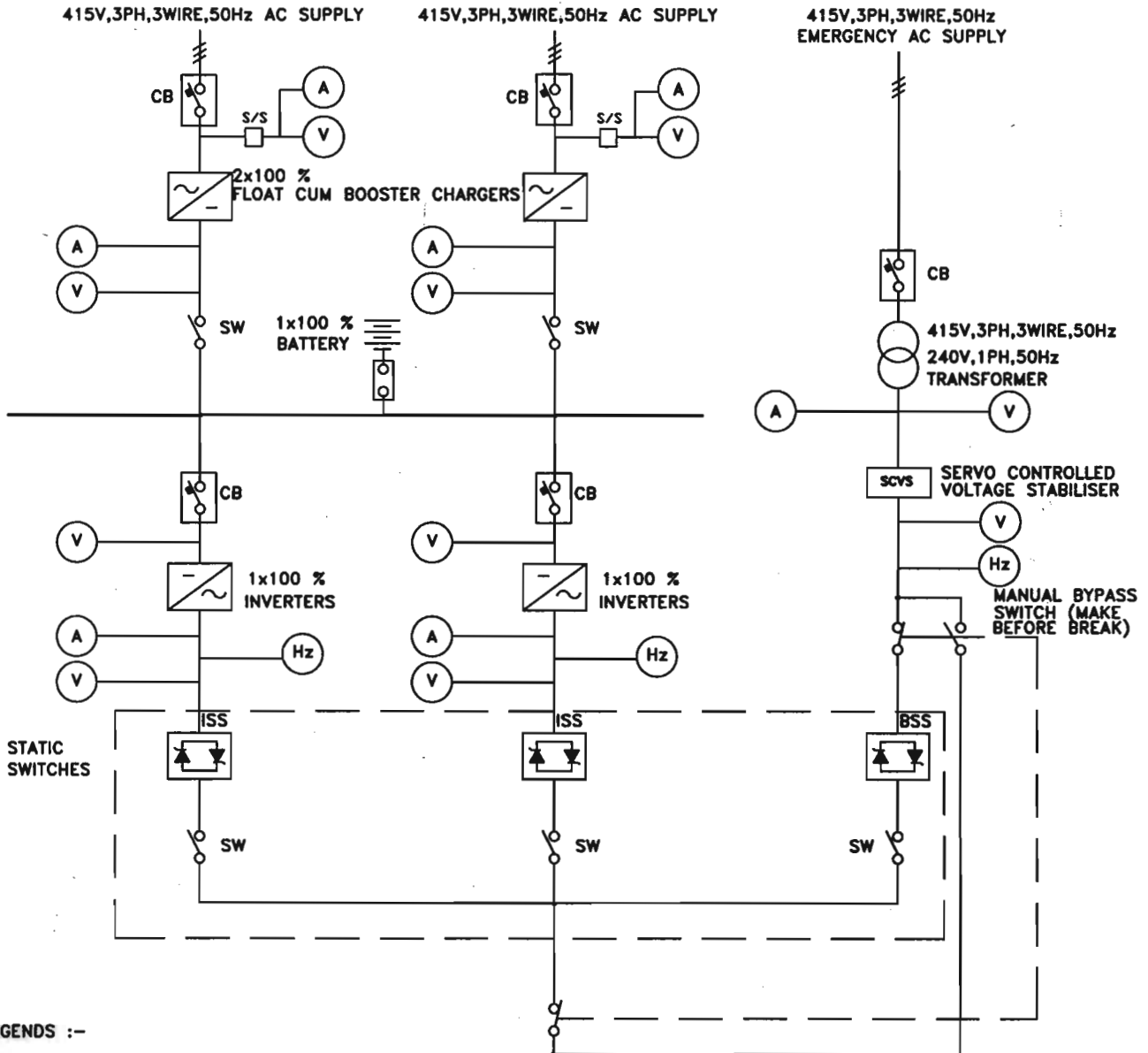

LEGENDS :-

- (A) AMMETER
- (V) VOLTMETER
- (Hz) FREQUENCY METER
- (KVA) KVA METER
- (PF) POWER FACTOR METER
- [CB symbol] CIRCUIT BREAKER
- [ISS symbol] STATIC SWITCH
- [SW symbol] SWITCH
- [MCB symbol] MCB
- [LINK symbol] LINK

- NOTE:-
1. MIMIC PANEL SHALL BE PROVIDED.
 2. TRANSDUCERS FOR VARIOUS METERS SHALL BE PROVIDED FOR GIVING 4-20mA ISOLATED SIGNALS FOR DAS.
 3. FEEDERS IN ACDB SHALL BE PROVIDED WITH MCB'S ON PHASE AND LINKS ON NEUTRAL.



TITLE : TECHNICAL SPECIFICATION
FOR
SELF CLEANING STRAINERS (SCS)

SPEC. NO. PE-TS-402-165-N003

VOLUME : IIB

SECTION : D

REV. NO. 0

DATE :30.05.2014

SHEET 1of 1

SECTION – D

STANDARD TECHNICAL SPECIFICATION

SECTION D1 : SELF CLEANING STRAINERS

SECTION D2 : ELECTRICAL SYSTEMS

SECTION D3 : C&I SYSTEM



TITLE : TECHNICAL SPECIFICATION
FOR
SELF CLEANING STRAINERS (SCS)

SPEC. NO. PE-TS-402-165-N003

VOLUME : IIB

SECTION : D

REV. NO. 0

DATE :30.05.2014

SHEET 1of 1

SECTION D1

STANDARD TECHNICAL SPECIFICATION FOR SELF CLEANING STRAINERS

	TITLE :	SPEC. NO. PE-TS- 999-165-N002
306262 (SHEET P/M)	STANDARD TECHNICAL SPECIFICATION	VOLUME : II B
	SELF - CLEANING FILTERS	SECTION : D
		REV. NO. 0 DATE : 02.12.2009
		SHEET 1 OF 10

1.00.00 **GENERAL**

This specification covers the Design, Performance and Operational Requirements, Constructional Features, Manufacture, Assembly. Inspection and Testing at the Manufacturer's and/or his Sub-contractor's works and Painting for delivery of Self-cleaning filter (Backwash Type) complete with all accessories as specified hereinafter.

2.00.00 **CODES AND STANDARDS**

2.01.00 The design, materials manufacture, inspection and testing of the self-cleaning filter complete with all accessories, shall comply with the requirements of the latest revisions of the following appropriate codes and standards :

2.01.01 IS / BS / DIN / US Standards regarding pressure vessels, pipes, flanges and others as necessary.

2.01.02 IS / BS / DIN / ASTM Standards for materials specification and testing procedures.

2.01.03 IS / BS / DIN / AWWA Standards for valves and their testing.

2.02.00 In case of any conflict between the above codes / standards and this specification, the later shall prevail and in case of any further conflict in the matter, the interpretation of the specification by the Engineer shall be final and binding.

3.00.00 **DESIGN AND CONSTRUCTION**

3.01.00 **General Requirements**

3.01.01 Unless otherwise necessary manufacturer's standard and proven models of the self cleaning filter shall be supplied.

3.01.02 The self-cleaning filter shall be capable of safe, proper and continuous operation. Vibration, noise, mechanical stresses shall be kept within allowable limits specified by relevant codes / standards, In design due attention shall be given to ease of maintenance, repair and cleaning.

3.01.03 Suitable corrosion allowance shall be provided wherever necessary.

3.01.04 Unless otherwise specified in Data Sheet-A, the inlet and outlets of the filter shall be co-axial without any off set between the centre lines of inlet and outlet pipes.

3.02.00 **Performance Requirements**

The self-cleaning filter with all accessories shall be designed and guaranteed to meet the following requirements :-

3.02.01 The self - cleaning filter shall perform satisfactorily under the flow and pressure conditions specified in Data Sheet -A and shall be capable of housing the various forms of debris / sludge i.e., suspended particles / matter, mussels, grass, leaves,

	TITLE :	SPEC. NO. PE-TS- 999-165-N002
बि एच डी एल	STANDARD TECHNICAL SPECIFICATION	VOLUME : II B
	SELF - CLEANING FILTERS	SECTION : D
		REV. NO. 0 DATE : 02.12.2009
		SHEET 2 OF 10

wood pieces etc. The performance of the filter shall be continuous with minimum number of flushing / backwashing operations.

3.02.02 The self-cleaning filter shall be designed such that the pressure drop across the filter (i.e., between inlet and outlet connections) under clean conditions and partially (50%) choked conditions shall not be more than those specified in Data Sheet -A.

3.02.03 Unless otherwise specified in Data Sheet -A, debris discharge / wash water flow rate during flushing/back washing operation shall be limited to 10% of the total flow rate and flushing / backwashing operation shall be completed within a period of maximum three (3) minutes. The pressure drop across the debris filter during flushing/backwashing operation shall not be more than the pressure drop under partially (50%) choked condition.

3.02.04 The coarse particles and floating matter accumulating at the filter section/screen are flushed out of the system by the debris flushing / backwash unit such that the pressure drop across the filter after flushing / backwashing, shall not be more than the pressure drop under clean conditions.

3.03.00 **Operational Requirement**

The self-cleaning filter and other accessories shall be designed for the following flushing/backwashing operation modes :

3.03.01 Complete automatic flushing/backwashing operation effected by the following :-

- ◆ differential pressure measuring system at a pre-determined differential pressure across the filter
- ◆ adjustable timer (0-24 hours)
- ◆ push button (for manual initiation of sequential flushing / backwashing)

3.03.02 Manual operation in the event of failure of control system.

3.04.00 **Filter Housing / Body**

3.04.01 The self-cleaning filter housing/body shall be designed and manufactured as per the applicable codes for pressure vessels. However in no case thickness of housing/ body shall not be less than connecting pipe thickness as specified in Data Sheet-A. It shall house the filter section / screen assembly and shall have flanged inlet, outlet, flushing / debris discharge openings and pressure measuring tappings etc.

3.04.02 In design of filter housing / body due attention shall be given for easy removal and replacement of filter section / screen assembly.

3.04.03 The filter shall be provided with inspection hole with bolted cover.

	TITLE :	SPEC. NO. PE-TS- 999-165-N002
	STANDARD TECHNICAL SPECIFICATION	VOLUME : II B
	SELF - CLEANING FILTERS	SECTION : D
		REV. NO. 0 DATE : 02.12.2009
		SHEET 3 OF 10

3.04.04 The filter body / housing shall be provided with vent and drain connections with isolating valves. It shall be possible to drain unfiltered and filtered water.

3.04.05 If specified in Data Sheet-A, filter body/housing shall be epoxy painted.

3.05.00 **Filter Section / Screen assembly.**

3.05.01 The filter section/screen shall be designed for the maximum differential pressure across the filter and shall be securely positioned by a supporting cage and shall be securely mounted in the housing or body.

3.05.02 The perforation/mesh size of the filter section shall not be more than that specified in Data Sheet-A.

3.05.03 The arrangement of the filter section shall be such that there shall be no forced accumulation of debris.

3.06.00 **Differential Pressure Measuring System**

3.06.01 The self-cleaning filter shall be provided with a measuring system for differential pressure across the filter section/screen, to check debris accumulation and to initiate flushing / backwashing operation. This shall consist of a separate differential pressure transmitter for normal automatic flushing operation and separate DP Switch as a backup in the event of DPT failure, a differential pressure gauge for manual observation with adequate no. of tappings with isolating valves and equalizing valves.

3.06.02 The contacts for differential pressure transmitter, differential pressure switch and for differential pressure gauge shall be independent so that in the event of failure of one, the other is available .

3.06.03 The differential pressure measuring system shall also be equipped with built in flushing arrangement consisting of flushing pump, valves and associated piping, to prevent blockage of the system with any debris. Unless otherwise specified in Section C, water required for flushing the differential pressure measuring system shall be taken from downstream side of the strainer/ screen.

3.07.00 **Flushing / Backwash Unit :**

3.07.01 The self-cleaning filter shall be provided with suitable flushing/backwash unit (to be installed at ground floor) and debris discharge/backwash outlet valve with associated actuator to flush out the accumulated debris / sludge.

3.07.02 The flushing pump shall be provided with mechanical seals to the extent possible. If gland packing is provided it should be of good quality to prevent leakage of water from pump glands.

3.07.3 The flushing backwash unit shall be either fixed type with actuator operated

	TITLE :	SPEC. NO. PE-TS- 999-165-N002
	STANDARD TECHNICAL SPECIFICATION	VOLUME : II B
	SELF - CLEANING FILTERS	SECTION : D
		REV. NO. 0 DATE : 02.12.2009
		SHEET 4 OF 10

flushing valves or electric motor driven (through reduction gear) backwash rotor. In case of backwash rotor, it shall be fitted with removable shoes for smooth and close running contact with the filter section/screen and to prevent the unfiltered water from bypassing to waste.

3.07.04 If any water is to be injected for backwashing the filter section/screen, water shall be taken from down-stream side of the filter section/ screen with necessary pump, valves and piping for water injection supplied by the bidder.

3.07.05 View glass to be provided in debris outlet pipe to monitor the flushing of debris.

3.08.00 **Valves**

The flushing valves (if any,) the debris discharge/backwash outlet valve, isolation, vent and drain valves shall conform to appropriate codes / standards. The debris discharge/backwash outlet valve shall be larger than the debris discharge/back wash outlet pipe.

3.09.00 **Instrumentation and Control System**

3.09.01 Complete instrumentation and control system for automatic flushing / backwashing operation, protection, interlocking, indication/annunciation of high differential pressure and other malfunctions etc. shall be provided. This shall consist of adequate operational hardware, local control panel and interconnecting control and power cabling between the control panel and the self-cleaning filter and its associated electrical devices.

3.09.02 The control panel shall house all necessary instruments, indicating/ annunciation lamps, alarms, differential pressure indicator, timer, function selector switches, relays, protection and interlocking systems, start/stop push buttons, counter to register number of flushing operations etc., and shall be complete with internal wiring. In addition to the above, the control panel shall meet the requirements of the enclosed specification.

3.09.03 All instrumentation shall be of reputed make and shall meet the requirement of the enclosed specification.

3.10.00 **Other Accessories.**

3.10.01 Counter flanges, flat faced slip on type, complete with gaskets, bolts and nuts etc., shall be supplied for the filter inlet, outlet connections and all other terminal points. Fabrication, dimensions and drilling of the flanges shall conform to the codes/standards specified in Data Sheet-A.

3.10.02 Self-cleaning filter shall be provided with suitable lifting arrangement for handling during erection and maintenance.

3.10.03 Necessary supporting arrangement (wherever applicable) complete with foundation plates, bolts, nuts etc., shall be provided.

	TITLE :	SPEC. NO. PE-TS- 999-165-N002
भारतीय रेल	STANDARD TECHNICAL SPECIFICATION	VOLUME : II B
	SELF - CLEANING FILTERS	SECTION : D
		REV. NO. 0 DATE : 02.12.2009
		SHEET 5 OF 10

3.11.00 **Material of Construction**

Material of self-cleaning filter and other accessories shall be corrosion resistant and consistent with the fluid handled. However material specification for various components shall be equal or superior to those specified in Data Sheet-A.

4.00.00 **PAINTING**

4.01.00 The surface preparation of the filter housing / body and other parts shall be done as per the standard mentioned in Data Sheet-A and shall include the following :

- a) Removal of oil, grease, dirt and swarf etc.
- b) Removal of rust and scale etc.
- c) Sand blasting/shot blasting.

4.02.00 All internal surfaces of the filter which are subject to immersion or water spray and which are not made of stainless steel or other corrosion resistant materials after surface preparation, shall be coated with adequate coats (minimum 200 to 250 microns thick) of epoxy paint of approved make and quality over a coat of zinc chromite primer, unless otherwise specified in Data sheet-A.

4.03.00 The external surfaces of the filter and other accessories after surface preparation, shall be coated with adequate coats (minimum 175 to 200 microns thick) of synthetic enamel paint of approved make and quality over two coats of red oxide primer, unless otherwise specified in Data Sheet-A.

5.00.00 **SHOP INSPECTION AND TESTS**

5.01.00 **General :**

5.01.01 Manufacturer shall conduct all tests and stage inspections as per the approved quality plan to ensure that the self-cleaning filter and other accessories shall conform to the requirements of this specification and of the applicable codes/standards.

5.01.02 All materials used for manufacture/fabrication of the filter shall be of tested quality. Relevant test certificates for chemical analysis, mechanical tests and heat treatment shall be made available before the final shop inspection. In case the relevant test certificates are not available, the manufacturer shall arrange to carry out the necessary tests as per approved quality plan and applicable codes at his cost, for which samples shall be identified by BHEL's representative.

5.01.03 All shop tests shall be conducted in the presence of BHEL's representative and test certificates / reports for the same shall be furnished to BHEL for approval.

5.01.04 Qualification of welding procedures and welders shall be as per ASME B&PV

	TITLE :	SPEC. NO. PE-TS- 999-165-N002
	STANDARD TECHNICAL SPECIFICATION	VOLUME : II B
	SELF - CLEANING FILTERS	SECTION : D
		REV. NO. 0 DATE : 02.12.2009
		SHEET 6 OF 10

- Code, Section-IX / applicable codes.
- 5.02.00 **Filter Housing / Body**
- 5.02.01 Chemical analysis, mechanical tests shall be carried out on housing/body material.
- 5.02.02 All butt welded joints shall be subjected to radiographic / ultrasonic testing as per applicable codes. However all welded joints shall be subjected to 100% magnetic particle / penetrant testing to ensure freedom from defects.
- 5.03.00 **Rubber Lining (as applicable)**
- Rubber lining shall be subjected to surface crack test, 100% spark and hardness tests and shall be checked for layer thickness, defects etc.
- 5.04.00 **Filter Section/Screen assembly**
- Supporting cage and filter section/screen materials shall be tested for chemical properties. Checks shall be carried out for perforation/mesh size, defects etc.
- 5.05.00 **Flushing / Backwash Unit**
- 5.05.01 Material of various components of the flushing/Backwash Unit shall be tested for chemical and mechanical properties.
- 5.05.02 Hollow shaft of backwash rotor shall be ultrasonically tested as per ASTM-A 388 for internal flaws. Penetrant test shall be carried out for surface flaws.
- 5.06.00 **Valves**
- Inspection and testing of valves including leakage test shall be carried out as per the requirements of the applicable standards. Correlating test certificates for materials of the valve components shall be furnished.
- 5.07.00 **Flanges**
- 5.07.01 In case of fabricated flanges, all the welds shall be subjected to 100% radiography as per ASME B&PV code, section VIII, Division-1.
- 5.07.02 In case of forged flanges, ultrasonic testing shall be carried out as per ASTM-E 388.
- 5.07.03 If the thickness of the plate used for flanged is 40mm or more the same shall be checked ultrasonically as per ASTM-A 435 to demonstrate the absence of lamination and lack of fusion etc.
- 5.07.04 Chemical and mechanical test certificates shall furnish for flange materials.
- 5.07.05 Flanges shall be checked for edge preparation, fit up and satisfactory working with

	TITLE :	SPEC. NO. PE-TS- 999-165-N002
	STANDARD TECHNICAL SPECIFICATION	VOLUME : II B
	SELF - CLEANING FILTERS	SECTION : D
		REV. NO. 0 DATE : 02.12.2009
		SHEET 7 OF 10

5.08.00 matching parts.
All materials for various nozzles, seals, pipes, gaskets, nuts bolts etc., shall be of tested quality and correlating test certificates for chemical and mechanical properties shall be furnished.

5.09.00 **Dimensional Checks**

Dimensional checks of various components of the filter shall be carried out as per the drawings approved by BHEL.

5.10.00 **Hydrostatic Test**

Hydrostatic test shall be conducted on the filter housing/body at a pressure of 2 times the design pressure. The duration of the test shall be minimum 30 minutes.

5.11.00 **Leakage Test**

Leakage test shall be conducted at the design pressure to demonstrate that the filter assembly is leak tight and no water seepage shall take place at various nozzle and valve connections.

5.12.00 **Functional Tests**

The self-cleaning filter assembly complete with valves, actuators and other accessories shall be subjected to functional tests and the following shall be checked :-

5.12.01 Smooth and free operation of all movable parts.

5.12.02 Interlocks and sequential operation.

5.12.03 Satisfactory operation of actuator torque switches, limit switches etc.

6.00.00 **TESTING AT SITE**

After completion of installation at site, the self cleaning filter with complete accessories, will be tested to check that the filter performance meets the requirements of its specification, Rectification of all defects shall have to be done by the supplier at no extra cost to the Owner / Purchaser. However the Owner / Purchaser reserves the right to reject the equipment / parts not meeting the requirement if the deficiency still persists.

7.00.00 **PERFORMANCE GUARANTEE**

7.00.00 **PERFORMANCE GUARANTEE & Bid evaluation criteria**

The Self cleaning strainer shall be guaranteed to meet the performance requirements specified in Section-D , Data Sheet A and Guarantee schedule and also for trouble free operation after commissioning. Schedule of performance guarantees (enclosed in

	TITLE :	SPEC. NO. PE-TS- 999-165-N002
	STANDARD TECHNICAL SPECIFICATION	VOLUME : II B
	SELF - CLEANING FILTERS	SECTION : D
		REV. NO. 0 DATE : 02.12.2009
		SHEET 8 OF 10

Volume III) duly filled and signed shall be furnished with the bid.

The Performance guarantees of equipments shall stand valid till the satisfactory completion of performance testing & its acceptance by BHEL/ Customer. If the guarantee period specified in the Commercial Specification is higher, same shall prevail.

7.01.00 Performance Guarantee Parameters shall be as under :

- Pressure drop in Self cleaning strainer in clean condition viz. after backwashing.

7.02.01 Bidder to note that bids shall be evaluated on account of pressure drop across Self cleaning strainer (in clean condition) & liquidated damages on account of not meeting the same shall be in accordance with following :

A) Bid Evaluation Criteria and Liquidated Damages:

The bids received shall be evaluated for Pressure drop across Self cleaning strainer:

- The permissible limit of pressure drop across Self cleaning strainer in clean condition shall be 0.6 MWC.
- If the pressure drops quoted are higher than above limit, the bids shall be technically loaded @ Rate as mentioned in Data Sheet-A for respective projects per 1 MWC pressure drop (viz. per unit).
- However no advantage shall be given for pressure drops quoted less than above permissible limit.
- The maximum acceptable limit for pressure drop across self cleaning strainer (with technical loadings) shall be 1.0 MWC

The bids will be technically rejected for pressure drops quoted higher than above maximum limit.

- The guaranteed pressure drops shall be demonstrated at site by vendors and if found higher shall be subject to LD @ twice the bid evaluation factor as above.

8.00.00 QUALITY ASSURANCE & QUALITY PLAN

8.01.00 The self - cleaning filter and other accessories to be supplied shall have assured quality and workmanship.

8.02.00 Typical quality plans (Q.P. No. PEM-MSE-SQP-07) are enclosed herewith this specification for bidder's guidance. The bidder shall comply with these minimum requirements and shall furnishing own quality plan based on materials and components of the filter being offered.

9.00.00 NAME PLATE AND TAG NUMBERS

9.01.00 The filter shall be provided with a permanently attached brass or stainless steel plate indicating the following details:-

	TITLE :	SPEC. NO. PE-TS- 999-165-N002
	STANDARD TECHNICAL SPECIFICATION	VOLUME : II B
	SELF - CLEANING FILTERS	SECTION : D
		REV. NO. 0 DATE : 02.12.2009
		SHEET 9 OF 10

- a) Design flow
- b) Design and test pressures
- c) Design temperature
- d) Filter section/screen mesh size
- e) Empty and operating weights
- f) Revolving speed of backwash rotor

9.02.00 Each valve shall be provided with a name plate indicating the following :-

- a) Service
- b) Design and test pressures
- c) Maximum flow and flow direction
- d) Size
- e) Engineer's Tag Number

Tag numbers will be indicated on the drawing submitted for approval during contract stage.

9.03.00 Each motor / actuator shall be provided with a name plate indicating the following details :

- a) Supply conditions.
- b) KW Rating
- c) Make

10.00.00 **DRAWINGS, DATA & INFORMATION TO BE SUBMITTED WITH THE BID**

The bidder shall furnish the following drawings, data and information alongwith the bid without which the offer will be deemed incomplete.

10.01.00 Data sheet-B with all particulars / data duly filled in.

10.02.00 General arrangement / installation drawings of the self-cleaning filter with all accessories, incorporating the principal dimensions and weights of equipment offered, size and location of various nozzle connections, supporting arrangement (if applicable) and scope of supply etc.

10.03.00 Cross-sectional / detailed drawings of filter housing / body, filter section / screen assemblies, flushing / backwashing unit, differential pressure measuring system, actuators, motors, control panel etc., indicating bill of quantities and materials of construction.

10.04.00 Flow and control logic diagrams for complete filter during normal and flushing / backwashing operations.

10.05.00 Performance evaluation procedure at site.

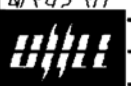
	TITLE :	SPEC. NO. PE-TS- 999-165-N002
बी एच डी एल	STANDARD TECHNICAL SPECIFICATION	VOLUME : II B
	SELF - CLEANING FILTERS	SECTION : D
		REV. NO. 0 DATE : 02.12.2009
		SHEET 10 OF 10

- 10.06.00 Control panel layout and list of instruments provided on control panel.
- 10.07.00 List of annunciations, protections and interlocks provided.
- 10.08.00 Write-up on operation, control, monitoring, interlocks and protection of filter.
- 10.09.00 Manufacturer's descriptive and illustrative literature on the equipments / components being offered.
- 10.10.00 A detailed experience list about the successful installations of similar equipment of equal or higher inlet / outlet sizes and flow capacities for similar application.
- 10.11.00 A comprehensive write-up on the testing facilities, tests to be conducted inspection methods and QA system adopted by the manufacturer.
- 10.12.00 Quality plan for the self-cleaning filter and for all its accessories.
- 11.00.00 **DRAWINGS, DATA & INFORMATION TO BE SUBMITTED AFTER THE AWARD OF CONTRACT :**
- The drawings, data and other documents as required in Data Sheet-C shall be furnished after the award of contract.



TITLE :
**DATA SHEET – A FOR
SELF CLEANING STRAINERS (SCS)**

SPECIFICATION NO. SPEC. NO. PE-TS-402-165-N003

**VOLUME : II B
SECTION : D**

REV. NO. 00 DATE : 11.09.2014

Page 1 of 9

S. No.	DESCRIPTION	UNITS	2X500 MW NNTPS
1.0	GENERAL		
1.1	Type of Strainers/ Filters	-	Self Cleaning Strainers
1.2	No. of Strainers/ Filters required	Nos.	Total 6 Sets for 2 units viz. i.e.(2 Working + 1 Standby) per unit
1.3	Inlet connection	mm Nb	600
1.3	Outlet connection	mm Nb	600
1.4	Filter type/ duty	-	On line / continuous
1.5	Location	-	ACW Pump Suction Header (Outdoor)
1.6	Liquid handled	-	Clarified Water as per analysis attached in Project information in section-B
2.0	DESIGN DATA		
2.1	Operating pressure	Bar (g)	2.0 to 3.0
2.2	Design pressure	Kg/cm ²)	7.5
2.3	Design temperature	Deg. C	60
2.4	Flow rate through filter		
	a) Normal		1900
	b) Maximum		2470



TITLE :
**DATA SHEET – A FOR
 SELF CLEANING STRAINERS (SCS)**

SPECIFICATION NO. SPEC. NO. **PE-TS-402-165-N003**

VOLUME : **II B**
 SECTION : **D**

REV. NO. **00** DATE : **11.09.2014**

Page 2 of 9

S. No.	DESCRIPTION	UNITS	2X500 MW NNTPS
2.5	Design differential pressure for filter section/ screen	Bar (g)	1.5 (Min.)
2.6	Type of suspended matter likely to enter the filter	-	Typical debris encountered in closed circuit CW system with Cooling Tower
2.7	Differential pressure measuring system set pressure <ul style="list-style-type: none"> • For initiating flushing/ backwashing • For alarm/ annunciation 	mbar	110
		mbar	160
2.8	Filter section/ screen perforation size	mm	2 mm (Max)
2.9	Free flow area in the screen basket	-	At least 120 % of pipe inlet area
3.0	GUARANTEED PERFORMANCE REQUIREMENT		
3.1	Pressure drop across the filter (i.e. between inlet and outlet connection) at normal flow	-	



TITLE :
**DATA SHEET – A FOR
 SELF CLEANING STRAINERS (SCS)**

SPECIFICATION NO. SPEC. NO. **PE-TS-402-165-N003**
 VOLUME : **II B**
 SECTION : **D**
 REV. NO. **00** DATE : **11.09.2014**
 Page 3 of 9

S. No.	DESCRIPTION	UNITS	2X500 MW NNTPS
	a) Clean condition	mbar	Refer Section – C of specification
	b) Partially (50%) choked condition	mbar	Not to exceed 110
3.2	Debris discharge flow during flushing period	Cub m/ Hr.	Not to exceed 2.5% of total flow rate
4.0	MATERIALS OF CONSTRUCTION		
4.1	Filter body/ housing	-	Carbon Steel as per IS:210 Gr. FG 260 with epoxy painted inside
4.2	Filter screen/ section	-	SS-316
4.3	Shaft	-	SS-316
4.4	Supporting cage	-	SS-316
4.5	Differential measuring system	-	SS-316
4.6	Flushing/ backwashing unit	-	SS-316
4.7	Backwash rotor shoes	-	Neoprene
4.8	Any other internal hardware /pipes etc.	-	SS-316 or eq.



TITLE :
**DATA SHEET – A FOR
 SELF CLEANING STRAINERS (SCS)**

SPECIFICATION NO. SPEC. NO. **PE-TS-402-165-N003**
 VOLUME : II B
 SECTION : D
 REV. NO. 00 DATE : 11.09.2014
 Page 4 of 9

S. No.	DESCRIPTION	UNITS	2X500 MW NNTPS
--------	-------------	-------	----------------

4.9	Valves	-	
4.9.1	Check Valves (65 NB & Above)		For sizes 65 NB and above-Swing check type or dual plate type.
	a) Body & Bonnet		Cast Carbon Steel (WCB), Flanged Ends
	b) Disc for Check Valve		Cast Carbon Steel (WCB)
	c) Stem		ASTM A182 Gr F6a
4.9.2	Check Valves (50 NB & Below)		For size 50 NB and below-Piston type
	a) Body & Bonnet		Forged Carbon Steel (A105), Screwed Ends
	b) Disc for Check Valve		Forged Carbon Steel (A105)
	c) Stem		ASTM A182 Gr F6a
4.9.3	Globe Valves 50 Nb & Below		
	Body, Bonnet & trim		Forged Carbon Steel (A105), Screwed Ends
4.9.3	➤ BF Valves (65 Nb & above)		
	➤ Body & Disc		ASTM A216 WCB
	➤ Shaft		ASTM A 182 F304
	➤ Stem		ASTM B132 Gr-A/ IS 320 HT2/ ASTM A182 Gr F6a
	➤ Sealing, Retaining segment & internals		18 – 8 SS
	➤ Bearings		Self lubricating
	➤ Companion Flange		IS 2062, Gr. B