

**GUJRAT STATE ELECTRICITY CORPORATION  
LTD. VADODARA, GUJRAT**

**1X800 MW WANAKBORI TPS EXT. UNIT-8**

**TECHNICAL SPECIFICATION  
FOR  
BUTTERFLY VALVE-STEAM SERVICE**

**SPECIFICATION NO. PE-TS-408-100-M016**



**BHARAT HEAVY ELECTRICALS LIMITED, POWER SECTOR  
PROJECT ENGINEERING MANAGEMENT  
NOIDA, INDIA**

	<b>TECHNICAL SPECIFICATION BUTTERFLY VALVE-STEAM SERVICE</b>	SPECIFICATION NO. PE-TS-408-100-M016	
		SECTION: -	
		REV. NO.: 00	DATE: 15.06.2016
		SHEET 1 OF 1	

## CONTENTS

S No.	SECTION	TITLE	NO. OF SHEETS
1.	SECTION-I	SPECIFIC TECHNICAL REQUIREMENTS	7
2.	SECTION-II	i) DATA SHEET-A ii) QUALITY PLAN iii) ACTUATOR DATA SHEET & WIRING DIAGRAM iv) COMPLIANCE SHEET	4 8 5 1

	<b>TECHNICAL SPECIFICATION BUTTERFLY VALVE-STEAM SERVICE</b>	SPECIFICATION NO. PE-TS-408-100-M016	
		SECTION: I	
		REV. NO.: 00	DATE: 15.06.2016
		SHEET 1 OF 1	

## SECTION-I

### SPECIFIC TECHNICAL REQUIREMENTS

	<b>SPECIFIC TECHNICAL REQUIREMENTS BUTTERFLY VALVES (STEAM SERVICE)</b>	SPECIFICATION NO. PE-TS-408-100-M016	
		SECTION C	
		REV. NO.: 00	DATE: 15.06.2016
		Sheet 1 of 7	

## 1. GENERAL

- 1.1 The valves shall meet the technical requirements and conform to the requirements of Section-I and Data sheet-A of Section-II. However, in the event of contradictions between Section-I & Section-II/Data Sheet-A, Data Sheet-A will prevail.
- 1.2 The technical requirements for valves shall, in general, be as per the attached Data sheet A of Section-II.

## 2. SCOPE OF SUPPLY

- 2.1 The valves complete with all accessories shall be supplied as per Data sheets A of Section-II. For detail refer the same. Each valve (quantity and other details specified in Data Sheet-A) shall be complete with the following accessories.
- i) Lifting arrangement provision for handling i.e., lifting lugs, eye bolts etc.
- ii) Actuators and limit switches as required to make valve complete in all respects.
- 2.2 Commissioning spares as per Data Sheet-A.
- 2.3 Set of special tools and tackles if required for the maintenance, erection etc. of the equipment supplied.
- 2.4 Mandatory spares as per Data Sheet-A.
- 2.5 Finish paints for touch-up painting of equipment after erection at site in sealed containers.

## 4.0 CODES AND STANDARDS:

The design, manufacture, inspection and testing of the butterfly valves shall suit the design parameters specified in datasheet-A & comply with the requirements of latest revisions of the following standards. However, the testing shall be as per American Water Works Association AWWA C504-10 and C516-10 (whichever is applicable) including disc strength test (all sizes of valves), gear box POD Test & Valve POD test.

- a) AWWA C504-10 upto size 1800 mm.
- b) AWWA C516-10 upto for size 2000 mm and above.

- 4.1 In case of any conflict between the above Codes/Standards and this specification, the later shall prevail and in case any further conflict in this matter, the interpretation of the specification by the BHEL engineer shall be final & binding.

## 5.0 DESIGN REQUIREMENTS:

- 5.1 All valves shall be suitable for the service conditions i.e. flow, temperature and pressure under which they are required to operate and those performing similar duties shall be interchangeable with each other unless otherwise specified.
- 5.2 The butterfly valves shall be suitable for Indoor/outdoor installation with shaft either in horizontal or vertical position.
- 5.3 The valves shall have double off-set type disc (design with shaft eccentric to disc) and long body design for AWWA C504-10 and maximum laying length for AWWA C516-10 as specified in Data sheet-A.

	<b>SPECIFIC TECHNICAL REQUIREMENTS BUTTERFLY VALVES (STEAM SERVICE)</b>	SPECIFICATION NO. PE-TS-408-100-M016	
		SECTION C	
		REV. NO.: 00	DATE: 15.06.2016
		Sheet 2 of 7	

5.4 The butterfly valves shall be with butt welded ends as specified in Data sheet-A and designed to ensure bubble tight shut off at the rated pressure of valve.

#### 5.5 MATERIALS

5.5.1 The materials of construction of main parts of the butterfly valves (steam service) shall be specified in Data sheet-A.

5.5.2 The materials of construction of the remaining parts shall be as per relevant standard governing the valves and to suit the service conditions. These materials shall be subject to approval of the purchaser.

5.5.3 Materials used in manufacture of valves shall be of tested quality.

#### 6.0 CONSTRUCTION FEATURES

##### 6.1 Valve Body

6.1.1 The valve body shall have integral hubs for shaft bearing housing. The minimum body shell thickness and minimum diameter of seat bore shall be as per requirement of the applicable table/equation of AWWA-C504-10/C516-10 (whichever is applicable). Material of construction of body and valve parts shall be as per materials indicated in Data sheet-A.

6.1.2 An arrow shall be embossed/ engraved and painted on the outside of body to clearly indicate the direction of flow.

##### 6.2 Valve Shaft

6.2.1 The shaft of each butterfly valve shall be securely attached to the disc through Bolting, Riveting, threading, upsetting or cross pinning, adequately locked.

6.2.2 Valve shaft design shall consist of one piece unit extending completely through the valve disc. or may be the "Stub Shaft" type which consists of two separate shafts inserted into the disc. Each stub shaft shall be inserted into the valve disc hubs for a minimum distance of at least 1.5 times shaft diameter. The connection between the shaft and the disc shall be designed to transmit shaft torque equivalent to at least 75% of the torsional strength of the minimum required shaft diameter. The minimum shaft diameter shall be as per the relevant standard and shall be such that it will safely sustain the maximum differential pressure across the closed valve and transmit the maximum torque required to operate the valve.

6.2.3 Surface finish for shaft shall be minimum 16 RMS in the area of gland packing.

##### 6.3 Valve Disc:

The valve disc shall have no external ribs transverse to the flow and shall sustain full differential pressure across closed valve disc without exceeding working stress of one fifth of the tensile strength of the material used. The thickness of the valve disc shall not be more than  $2 \frac{1}{4}$  times the shaft diameter listed in AWWA-C504-10/C516-10 (whichever is applicable). The valve disc shall be designed to rotate  $90^\circ$  from full open to tight shut off position. Material of Disc shall be as per the Data sheet-A1.

##### 6.4 Body Seat & Disc Seal (Valve seat)

The soft seat shall be of replaceable type of suitable grade resilient material, adequately reinforced, securely attached to the disc or to the body, and shall be

	<b>SPECIFIC TECHNICAL REQUIREMENTS BUTTERFLY VALVES (STEAM SERVICE)</b>	SPECIFICATION NO. PE-TS-408-100-M016	
		SECTION C	
		REV. NO.: 00	DATE: 15.06.2016
		Sheet 3 of 7	

designed to provide bubble tight shut off under all operating conditions. The soft seat/ seal shall be attached by clamping ring, bolting or other suitable methods as per the standard design of the manufacturer. All clamping rings, bolts/studs, nuts used shall be of stainless steel. The sealing ring on the disc shall be continuous type and easily replaceable.

The mating seat surface accordingly shall be on valve body or disc and shall be of stainless steel and securely attached to the body/disc by directly clamping, bolting or suitable methods. All clamps, retaining rings, nuts, screws / all hardware shall be of stainless steel.

6.5 Valve Bearing:

Each butterfly valve shall be fitted with sleeve type bearings contained in the hub of the valve body. The bearing shall be of self-lubricating type and the coefficient of friction of bearing material shall not exceed 0.25 when rubbing at the maximum bearing pressure. The housing for this bearing shall be rigidly attached to the valve body. Thrust bearings shall also be provided for vertical shaft installation. For valves of 350 NB and larger, the bearing should be capable of taking axial thrust also. The material of the bearing shall be self-lubricated type & low coefficient of friction in accordance with the relevant standard.

6.6 Shaft Seal:

Wherever the shaft project through the valve body for actuator connection, a shaft seal shall be provided. Shaft seal shall be designed for use of Standard 'O' rings seals and they shall be contained in a removable corrosion resistant recess. Shaft seals shall be designed to allow its replacement without removal of the valve shaft.

The hand wheel shall be of malleable iron or equivalent.

6.8 Body Ends:

These shall be as butt welded as per ASME B 16.25 as specified in Data sheet-A1.

6.9 Nameplate:

Each valve & handwheel shall be fitted with a circular Stainless steel 2mm thick nameplate indicating the valve Tag No. and service description given in Data sheet-A. All details shall be engraved 1 mm deep and filled with black enamel paint.

6.10 The stops which limit the travel of any valve in the 'Open' or 'Shut' position shall be arranged exterior to the valve body.

6.11 All valves shall be closed by rotating the handwheel in a clockwise direction when looking at the face of the handwheel. The pulling force required on handwheel rim shall not exceed 25 Kgf when operating the valve under full flow and operating pressure. The face of each hand wheel shall be clearly marked with the words 'Open' and 'Shut' with adjacent arrows to indicate the direction of rotation to which each refers.

6.12 Special attention shall be given to the operating mechanism for large size valves in order that quick and easy operation is obtained and maintenance is kept to a minimum.

	<b>SPECIFIC TECHNICAL REQUIREMENTS BUTTERFLY VALVES (STEAM SERVICE)</b>	SPECIFICATION NO. PE-TS-408-100-M016	
		SECTION C	
		REV. NO.: 00	DATE: 15.06.2016
		Sheet 4 of 7	

- 6.13 Eyebolts shall be provided where necessary to facilitate handling heavy valves or part of valves.
- 6.14 Wherever practical, valves (including actuator, drive motor, integral bypass etc.) of total weight equal to or greater than 500 Kg shall be provided with suitable lugs to permit direct suspension by hanger rods or direct resting on bottom support, as applicable.
- 6.15 The valves as well as accessories shall be designed for easy dismantling and maintenance.
- 6.16 The disc shall rotate through 90° from full open to the tight shut position. The disc shall be contoured to ensure the least possible resistance to flow and be suitable for throttling operation. While the disc is in throttled position, the valve shall not create any noise or vibration.
- 6.17 It may be noted that all construction features design and parameters will be governed by AWWA-C504-10 for sizes upto 1800 mm and AWWA-C516-10 for sizes 2000 mm and above.

7.0 SPECIAL FEATURES:

7.1 Gland Sealing Arrangement:

Butterfly valves, provided with gland sealing arrangement, shall be vacuum tested. All valves required with this arrangement shall be provided with G3/8" connection (duly plugged) for water sealing. Sealing water shall be supplied at 4 ata and 50°C unless otherwise specifically indicated for the particular project.

- 7.2 Valves subjected to vacuum shall have sufficient long deep-seated packing. Valves in general shall preferably be of such design as to permit repacking while in service by providing back seating arrangement duly tested during manufacture.

7.3 Motorised Valves:

- 7.3.1 The motorised valves shall be offered with the electric actuators of reputed make. A particular make and type of actuator shall be designed for the maximum differential working pressure. However, the stall torque of the selected actuators shall be minimum 1.5 times the valve unseating torque requirement at the maximum differential working pressure (design pressure) and required operating time as mentioned in in Datasheet A.

- 7.3.2 Electric actuators shall be mounted directly on the valves.

- 7.3.3 The motors, gearing and disengaging hand wheel shall be adequate to open and close the valve under maximum differential pressure and shall be completely assembled on the respective valve and shop tested before shipment.

Gear box and Electric Actuator shall also meet the inspection & testing requirements of latest revision of AWWA-C504-10 /AWWA C542-10 respectively.

	<b>SPECIFIC TECHNICAL REQUIREMENTS BUTTERFLY VALVES (STEAM SERVICE)</b>	SPECIFICATION NO. PE-TS-408-100-M016	
		SECTION C	
		REV. NO.: 00	DATE: 15.06.2016
		Sheet 5 of 7	

## 8.0 INSPECTION AND TESTING:-

All inspection & Testing for valve, Gear box and actuators shall be as per the requirements of the relevant standard.

The minimum NDT/testing and inspection requirements for valve, Gear Box, electric actuator etc. shall be as per the attached Quality Plan. However, in case of order, final inspection and testing shall be carried out as per the final approved quality plan without any price implications.

### 8.1 P.O.D. Tests:

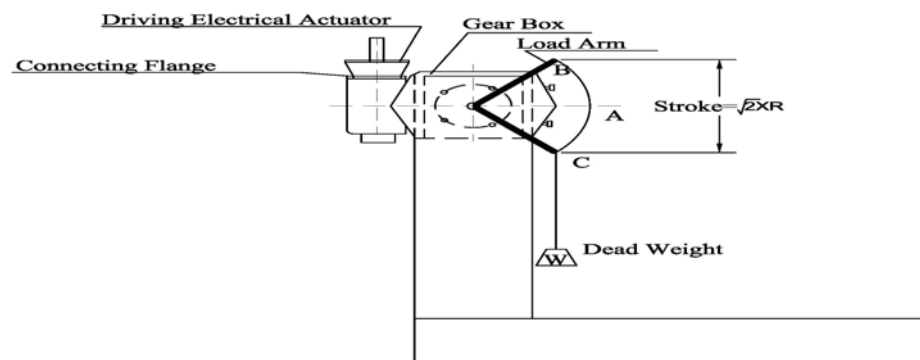

**TEST SET UP**

FIG. 1

- a) POD (Proof-of-design) Test as per AWWA-C504-10/C516-10 (whichever is applicable) is required to be carried out for valves. In case the valve POD Test has been done earlier, only Test Report of POD test for same model/ type/size/ rating is required to be submitted for verification.
- b) Gear Box and Electric Actuator shall be designed & tested in accordance with latest editions of AWWA C 504-10(gearbox) and AWWA C 542-10 (actuator) respectively. Gear Box shall be designed to hold the valve disc in intermediate position between full open and full closed position without creeping or fluttering.
- c) For valves designed and manufactured as per AWWA POD shall follow the guidelines of AWWA-C504-10/C516-10 (whichever is applicable) and Actuators shall meet the requirements of POD test of AWWA-C-542-10.
- d) Gear box POD test: - Valve POD and gear box POD tests should be done separately on each one of the valve & the gear box. Gear box POD test shall be done as per the procedure described below or as per the procedure agreed between purchaser & vendor.
- e) Gear box POD Test shall be carried out only at full rated torque of gear box, throughout the full cycle of testing i.e. at no point during each full cycle of testing; the applied torque should be less than the full rated torque of Gear Box. Refer Sketch for Gear Box POD test set up. Dead weight and length of arm shall be so selected that the

	<b>SPECIFIC TECHNICAL REQUIREMENTS BUTTERFLY VALVES (STEAM SERVICE)</b>	SPECIFICATION NO. PE-TS-408-100-M016	
		SECTION C	
		REV. NO.: 00	DATE: 15.06.2016
		Sheet 6 of 7	

torque generated at point “C” and “B” shall in no case be less than the full rated torque of the gear box.(refer fig.1)

- f) Irrespective of the requirement of conducting the type tests, the vendor shall submit the reports of the type tests carried out within last five years from the date of bid opening. These reports should be for the tests conducted on the equipment same (model / type/ size / rating) to those proposed to be supplied. Tests should have been conducted at an independent laboratory or should have been witnessed by a client.

These valves are for vacuum service and shall be provided with gland sealing arrangement which shall be vacuum tested with vacuum and helium gas.

#### 9.0 PERFORMANCE GUARANTEE:

9.1 The vendor shall guarantee the material & workmanship of all components as well as operation of the equipment as per the requirements of the specification.

9.2 The vendor shall also guarantee the following for each butterfly valve:

- a) Pressure drop as per the approved drop vs. opening curve.
- b) The valve opening and closing time.

#### 10.0 EXCLUSIONS:

Erection & Commissioning of equipment at site.

#### 11.0 QUALITY ASSURANCE

The Quality Plans enclosed with this specification specify minimum quality control requirement. During contract stage vendor shall furnish these Quality Plans duly signed & stamped for their compliance. Quality plans shall be approved by BHEL and customer (If necessary). All inspection and testing shall be carried out by BHEL and CUSTOMER (if necessary). In case inspection is by both BHEL and CUSTOMER, then the inspection can be carried out jointly or separately, which will be informed later.

#### 12.0 PAINTING REQUIREMENT:

Surface preparation shall be as per SSPC-SP-3/ Power Tool Cleaning followed by 2 coat of Heat Resistance Aluminium paint to IS 13183 Gr. I or equivalent, paint shade Aluminium and total DFT of paint will be equal to 120 microns minimum.

#### 13.0 PACKING INSTRUCTIONS:

- a) Each valve shall be drained, cleaned, prepared and suitably protected in such a way so as to minimize the possibility of damage and deterioration during transit and storage.
- b) The valve has to be dispatched in total assembled form.
- c) Discs of all valves shall be properly secured while dispatching so that there is no risk of damage to the disc & seat.
- d) Body ends shall be suitably sealed to protect them against damage during transit and storage.

	<b>SPECIFIC TECHNICAL REQUIREMENTS BUTTERFLY VALVES (STEAM SERVICE)</b>	SPECIFICATION NO. PE-TS-408-100-M016	
		SECTION C	
		REV. NO.: 00	DATE: 15.06.2016
		Sheet 7 of 7	

- e) Valves with butt-welding ends shall be protected by means of polythene caps/rubber and protectors to prevent damage to ends & also to avoid foreign material entering the valve while shipment & storage.
- f) Valve Tag Nos. shall be incorporated in all the dispatch documents.
- g) Proper care shall be taken to avoid damage to the painted surface during transit.
- h) All the valves shall be packed suitably in wooden cases in order to avoid damage during transit and also during storage at site in tropical climate conditions for a period of 15-18 months.
- i) Vendor to provide the following:
  - Photographs of Valves/traps duly placed inside the wooden box just before final packing.
  - Photographs of the wooden box in which the valves have been finally packed just before dispatch.

Clearance for dispatch of valves/traps will be given only after receiving the photos of valves/traps in satisfactory condition as mentioned in the condition stated above.

#### 14.0 SPARES

- a) **Mandatory Spares:** These shall be as per Data Sheet-A.
- b) Order for the spares may be placed simultaneously or otherwise at the option of purchaser.

#### 15.0 DOCUMENTS TO BE SUBMITTED ALONG WITH OFFER

Bidder shall submit the following documents duly filled, signed and stamped along with the bid:

- a) Compliance sheet
- b) Documents as per the list indicated in the NIT.

The above are the only documents which will be used for technical evaluation unless other documents are asked for during technical clarifications. Any other technical document enclosed with the bid shall be ignored for the purpose of technical evaluation. All other documents attached with the specification are for information of the vendor and no comments shall be marked on these

	<b>TECHNICAL SPECIFICATION BUTTERFLY VALVE-STEAM SERVICE</b>	SPECIFICATION NO. PE-TS-408-100-M016	
		SECTION: -	
		REV. NO.: 00	DATE: 15.06.2016
		SHEET 1 OF 1	

## SECTION-II

- DATA SHEET – A
- QUALITY PLAN
- ACTUATOR DATA SHEET & WIRING DIAGRAM
- COMPLIANCE SHEET



	<b>DATA SHEET-A</b> <b>BUTTERFLY VALVES (STEAM SERVICE)</b> <b>1X800 MW WANAKBORI TPS EXT.</b> <b>UNIT-8</b>	SPECIFICATION NO. PE-TS-408-100-M016	
		SECTION II	
		REV. NO.: 00	DATE: 15.06.2016
		Sheet Page 2 of 4	

**Material of Construction**

SL NO.	PART NAME	MATERIALS
<b>VALVE</b>		
a.	Valve Body Butt welded: (Long body butt weld ends )	ASTM A-216 Gr. WCB
b.	Valve Disc.	ASTM A-216 Gr.WCB
c.	Shaft	ASTM A182 Gr..F304
d.	Disc Seal/Seat	EPDM (70 ~ 75 SHORE 'A')
e.	Valve body seat edge	AISI 316 (WELD OVERLAY/ DEPOSIT)
f.	Seat retaining ring and internal Bolts etc.	SS 304/316
g.	Bearing	SLEEVE TYPE, SELF LUBRICATED
h.	Shaft seal :	'O' RINGS TYPE ( 65~70 SHORE 'A')
i.	Fasteners (bolts & nuts)	ASTM A193 Gr. B7 (BOLTS) / ASTM A194 Gr. 2H(NUTS)
j.	Hand wheel (actuator)	MALLEABLE IRON (NO OTHER ALTERNATE MATERIAL ACCEPTABLE)
<b>GEAR BOX. (Bevel type)</b>		
k.	Main Housing /Cover (Totally enclosed construction)	Cast Iron IS:210 Gr. FG 220/260
l.	Input shaft	13/% Cr SS/ EN8 ( ~200 BN)
m.	Worm	EN8 ( ~200 BN)
n.	Worm Wheel	Ductile iron / S.G iron
o.	Hand wheel	Malleable Iron

	<b>DATA SHEET-A</b> <b>BUTTERFLY VALVES (STEAM SERVICE)</b> <b>1X800 MW WANAKBORI TPS EXT.</b> <b>UNIT-8</b>	SPECIFICATION NO. PE-TS-408-100-M016	
		SECTION II	
		REV. NO.: 00	DATE: 15.06.2016
		Sheet Page 3 of 4	

### TECHNICAL REQUIREMENTS

- |     |                                   |   |   |                             |
|-----|-----------------------------------|---|---|-----------------------------|
| 1.  | Tag no.                           | : | EXV-31 & EXV-32   |                             |
| 2.  | Quantity                          | : | One each (total 2 nos.) per unit  |                             |
| 3.  | Total Qty.                        | : | total 2 nos   |                             |
| 4.  | Type                              | : | Resilient seal.   |                             |
| 5.  | Service                           | : | Butterfly valves shall be located in the exhaust ducts of the auxiliary drive turbines of the boiler feed pumps to isolate the aux. drive turbine from the surface condenser. |                             |
| 6.  | Size (Nominal) mm                 | : | 2000  |                             |
| 7.  | Flow medium                       | : | Wet Steam, 2-7% moisture  |                             |
| 8.  | Flow Velocity (Design)            | : | 100 m/sec   |                             |
| 9.  | Operating parameters              | : | <u>At normal condition</u>  | <u>At maximum condition</u> |
| 9.1 | Pressure (kg/cm <sup>2</sup> (a)) | : | 0.0836  | 0.0871                      |
| 9.2 | Flow (T/hr)                       | : | 59.481  | 67.069                      |
| 9.3 | Dryness fraction                  | : | 0.94  | 0.938                       |

	<b>DATA SHEET-A</b> <b>BUTTERFLY VALVES (STEAM SERVICE)</b> <b>1X800 MW WANAKBORI TPS EXT.</b> <b>UNIT-8</b>	SPECIFICATION NO. PE-TS-408-100-M016	
		SECTION II	
		REV. NO.: 00	DATE: 15.06.2016
		Sheet Page 4 of 4	

### TECHNICAL DATA

- |     |                                     |   |   |
|-----|-------------------------------------|---|---|
| 1.  | Design Pressure                     | : | Full vacuum and 2 kg/cm <sup>2</sup> (g)    |
| 2.  | Design temp.                        | : | 100 Deg. C                                  |
| 3.  | End Connections                     | : | Butt welded                                 |
| 4.  | Connecting pipe size and material   | : | OD 2032 x 16 thk.<br>SA672 Gr. B60 Cl.12/22 |
| 5.  | Valve operation type                | : | Motor operated                              |
| 6.  | Shaft Axis orientation              | : | Horizontal                                  |
| 7.  | Pipe line axis orientation          | : | Horizontal                                  |
| 8.  | Operation                           | : | Full open & full close                      |
| 9.  | Design pressure drop at max. flow.: |   | 0.0002 kg/cm <sup>2</sup> (max.)            |
| 10. | Valve rating                        | : | Class 75B (minimum) of AWWA C516/10         |



**QUALITY PLAN**

CUSTOMER: M/S GSECL  
VENDOR: LATER

PROJECT: 1X800 MW WANAKBORI TPS EXT. UNIT-8  
REV.00 dtd. 25-09-2015

SPEC NO.: PE-TS-408-100-M016

SPEC. TITLE STANDARD SPEC. FOR TWO WAY  
BF VALVE FOR STEAM SERVICE

SHEET 1 OF 8

SYSTEM STEAM SERVICE

ITEM: CAST CARBON STEEL BUTTERFLY VALVE  
UPTO SIZE 2000 NB MOTORIZED

SECTION - VOLUME

S.N O.	COMPONENT/ OPERATION	CHARACTERISTICS CHECKED	CAT E-GO RY	TYPE/METH- OD OF CHECK	EXTENT OF CHECK	REFERENCE DOCUMENT	ACCEPTANCE NORMS	FORMAT OF RECORD	AGENCY	REMARKS
									P W V	

1.	MATERIALS											
1.1	BODY, DISC, SHAFT	1. CHEM. COMPOSITION & MECH. PROPERTIES	MA	1) CHEM. TESTS	ONE PER HEAT	APPD DRG/ TECH SPEC	APPD DRG/ TECH SPEC	TEST CERT.	3/2	2	1	
				2) MECH TESTS	ONE PER HEAT & HEAT TREATMENT BATCH	APPD DRG/ TECH SPEC	APPD DRG/ TECH SPEC	TEST CERT.	3/2	2	1	SHAFT MECHANICAL TEST WITNESS BY BIDDER
	BODY, DISC	2. INTERNAL DEFECTS OF CASTINGS	MA	1. MPI	100%	ASTM E 709	ASME B16.34	NDT REPORT	3/2	2	1	MPI ON 100% AREA (ACCESSIBLE)
				2. RT	100%	ASME B16.34	ASME B16.34	NDT REPORT	3/2	2	1	RT ON CHANGE OF SECTION AND BW ENDS OF BODY (RT FILM REVIEW)
				3. CASTING DEFECTS	100%	MSS SP55	MSS SP55	INSP REPORT	3/2	2	1	**NORMAL BEAM PROBE OF 20 MM/10 MM DIA AND 2/2.5 MHz SHALL BE USED. USING THIS PROBE THE BACK WALL ECHO SHALL BE SET AT 100% FULL SCREEN HEIGHT(FSH) IN SOUND AREA. AT THIS SENSITIVITY LEVEL THE ITEM SHALL BE SCANNED AND ANY DEFECT ECHO MORE THAN 20% FSH IS NOT ACCEPTABLE. ALSO ANYWHERE MORE THAN 20% LOSS OF BACK WALL ECHO IS NOT ACCEPTABLE
	SHAFT	4. SUB-SURFACE DEFECTS OF SHAFT DIA > 50 MM	CR	UT	100%	ASTM A388	REFER REMARKS**	INSP REPORT	3/2	2	1	
1.2	CLAMP RING	CHEM., MECH PROPS	MA	1) CHEM. TESTS	ONE PER HEAT	APPD DRG/ TECH SPEC	APPD DRG/ TECH SPEC	TEST CERT.	3/2	2	1	
				2) MECH TESTS	ONE PER HEAT & HEAT TREATMENT BATCH	APPD DRG/ TECH SPEC.	APPD DRG/ TECH SPEC	TEST CERT.	3/2	2	1	

BHEL		PARTICULARS		BIDDER/VENDOR	
		NAME			
		SIGNATURE			
		DATE			

*Anuj Awasthi*  
Engineer, MPL

BIDDER'S/ VENDOR'S COMPANY SEAL



**QUALITY PLAN**

CUSTOMER: M/S GSECL  
VENDOR: LATER

PROJECT: 1X800 MW WANAKBORI TPS EXT. UNIT-8  
REV.00 dtd. 25-09-2015

SPEC NO.: PE-TS-408-100-M016

SPEC. TITLE STANDARD SPEC. FOR TWO WAY  
BF VALVE FOR STEAM SERVICE

SHEET 2 OF 8

SECTION - VOLUME

S.N O.	COMPONENT/ OPERATION	CHARACTERISTICS CHECKED	CAT E- GO RY	TYPE/METH- OD OF CHECK	EXTENT OF CHECK	REFERENCE DOCUMENT	ACCEPTANCE NORMS	FORMAT OF RECORD	AGENCY	REMARKS	
SYSTEM			STEAM SERVICE						P	W	V

1.3	DISC SEAL (FROM VENDOR'S REGULAR & APPROVED SOURCE)	1. VISUAL INSPN	MA	VISUAL	100%	APPD DRG	APPD DRG	INSPN REPORT	3/2	2	1	
		2. DIMENSIONS	MA	MEASURE- MENT	100%	APPD DRG	APPD DRG	LOG BOOK	3/2	2	1	
		3. TENSILE AND HARDNESS FOR VULCANISING	MA	MEASUREM ENT	100%	APPD DRG	APPD DRG	TEST CERT	3/2	2	1	
		4. OZONE CRACK RESISTANCE	MA	TESTING	1/BATCH	TECH. SPEC + ASTM D1149	TECH. SPEC + ASTM D1149* AWWA C 504	TEST CERT.	3/2	2	1	SPECIMEN TYPE A, 40 DEG CENTIGRADE FOR 70 HRS
		5. ELONGATION	MA	TESTING	1/BATCH	IS-3400 PART-I	250% MIN	TEST CERT	3/2	2	1	
		6. BLEED RESISTANCE	MA	TESTING	1/BATCH	SAMPLE TO BE KEPT IN 33% HCL. DM WATER, 48% NaOH FOR 72 HRS.	NO DISCOLO- URATION. WEIGHT GAIN +/- 0 TO 2%	TEST CERT	3/2	2	1	
		7. AGEING TEST	MA	TESTING	1/BATCH	TECH. SPEC + IS 3400 PART IV	TECH. SPEC +IS3400 PART IV *	TEST CERT	3/2	2	1	*-TEST TEMP. 125 DEG C, TEST DURATION 72 HRS, MAX CHANGE IN TENSILE STRENGTH. 20% ELOGATION: 20%, HARDNESS:3%
		8. HYDRAULIC STABILITY TEST (AFTER AGEING)	MA	TESTING	1/BATCH	TECH SPEC./ REL STD.	TECH SPEC./ REL STD.	TEST CERT	3/2	2	1	
		9. WEAR RESISTANCE	MA	TESTING	TYPE TEST	AWWA C- 504/C516	NO DAMAGE	TEST REPORT	3/2	2	1	TYPE TEST REPORT WILL BE FURNISHED FOR REVIEW
1.4	FASTENERS ASTM 193 GR B7 ASTM 194 GR2H, GRB8M	1. VERIFICATION OF MAKE, GRADE, REVIEW OF TEST CERTIFICATE	MI	VISUAL	100%	TECH. SPEC/ DATA SHEET	TECH. SPEC/ DATA SHEET	INSPN REPORT	3/2	2	1	
		2. DIMENSIONS	MA	MEASURE- MENT	SAMPL- ING PLAN	APPD DRG	APPD DRG	INSP REPORT	2	2	1	

BHEL		BIDDER/VENDOR	
		PARTICULARS	
		NAME	
		SIGNATURE	
		DATE	
		BIDDER'S/ VENDOR'S COMPANY SEAL	

*Anuj Awasthi*  
Engineer, MPL



**QUALITY PLAN**

SHEET 3 OF 8

CUSTOMER: M/S GSECL  
VENDOR: LATER

PROJECT: 1X800 MW WANAKBORI TPS EXT. UNIT-8  
REV.00 dtd. 25-09-2015

Q.P. NO.: PE-QP-408-100-M016

SPEC. NO.: PE-TS-408-100-M016

SPEC. TITLE STANDARD SPEC. FOR TWO WAY  
BF VALVE FOR STEAM SERVICE

ITEM: CAST CARBON STEEL BUTTERFLY VALVE  
UPTO SIZE 2000 NB MOTORIZED

SECTION - VOLUME

S.N O.	COMPONENT/ OPERATION	CHARACTERISTICS CHECKED	CAT E-GO RY	TYPE/METH- OD OF CHECK	EXTENT OF CHECK	REFERENCE DOCUMENT	ACCEPTANCE NORMS	FORMAT OF RECORD	AGENCY	REMARKS
									P W V	

1.5 OPERATORS	1.5 OPERATORS	1.5 OPERATORS	1.5 OPERATORS	1.5 OPERATORS	1.5 OPERATORS	1.5 OPERATORS	1.5 OPERATORS	1.5 OPERATORS	1.5 OPERATORS	1.5 OPERATORS
A) GEAR, WORM & SHAFT (BS970G-E#8)	1. CHEM. COMP. & PHYS PROPERTIES	MA	CHEM & PHYS TEST	1/BATCH	RELV STD/ DATA SHT/ MFG DRG	RELV STD/ DATA SHT/ MFG DRG	TEST CERT	3/2	2	1
	2. DIMENSIONS	MA	MEASURE- MENT	100%	RELV STD/ DATA SHT/ MFG DRG	RELV STD/ DATA SHT/ MFG DRG	INSP REPORT	3/2	2	1
	3. HARDNESS	MA	MEASURE- MENT	100%	RELV STD/ DATA SHT/ MFG DRG	RELV STD/ DATA SHT/ MFG DRG	TEST CERT	3/2	2	1
	B) TORQUE TEST	MA	TORQUE TEST AT TWICE THE RATED TORQUE	ONE/ TYPE/ MODEL/ RATING	AWWA C-504/ C-516/ DATA SHT/ MFG DRG.	AWWA C-504/ C-516/ DATA SHT/ MFG DRG.	INSP REPORT*	3/2	1*	--
1.6 ELECTRICAL ACTUATOR	2. DESIGN VERIFICATION	MA	CYCLE TEST AT FULL RATED TORQUE OF GEAR BOX	ONE/ TYPE/ MODEL/ RATING	AWWA C-504/ C-516 (AT FULL RATED TORQUE OF GEAR BOX) / APPD PROCEDURE	AWWA C-504/ C-516/ APPD PROCEDURE	INSP REPORT*	3/2	1*	--
	1. TORQUE TESTING & SETTING OF TORQUE SWITCH	MA	{MECH, } {ELEC. } {TESTS } { }	100%	TECH. SPEC./ APPD. DRG./ DATA SHEET/ IS:9334	TECH. SPEC./ APPD. DRG./ DATA SHEET/ IS:9334	INSP REPORT	3	2	1

BHEL		PARTICULARS		BIDDER/VENDOR	
		NAME			
		SIGNATURE			
		DATE			
				BIDDER'S/ VENDOR'S COMPANY SEAL	

*Anuj Awasthi*  
Engineer, MPL



**QUALITY PLAN**

SHEET 4 OF 8

CUSTOMER: M/S GSECL  
VENDOR: LATER

PROJECT: 1X800 MW WANAKBORI TPS EXT. UNIT-8  
QP NO.: PE-QP-408-100-M016  
REV.00 dtd. 25-09-2015

SPEC NO.: PE-TS-408-100-M016  
SPEC. TITLE STANDARD SPEC. FOR TWO WAY  
BF VALVE FOR STEAM SERVICE

SYSTEM: STEAM SERVICE  
ITEM: CAST CARBON STEEL BUTTERFLY VALVE  
UPTO SIZE 2000 NB MOTORISED

SECTION - VOLUME

S.N O.	COMPONENT/ OPERATION	CHARACTERISTICS CHECKED	CAT E-GO RY	TYPE/METH- OD OF CHECK	EXTENT OF CHECK	REFERENCE DOCUMENT	ACCEPTANCE NORMS	FORMAT OF RECORD	AGENCY	REMARKS
									P W V	

2.	TRAVEL/STROKE		MA	}}						
3.	TRAVEL TIME		MA	}}						
4.	OPERATION OF LIMIT SWITCH		MA	}}						
5.	MANUAL OPERATION THROUGH HAND WHEEL		MA	}}						
6.	OPERATION TEST WITH POWER SUPPLY VARIATION ENERGISES TO OPEN/CLOSE		MA	}}						
7.	IR.HV,IR		MA	}}						
8.	DEGREE OF PROTECTION		MA	}}	1/TYPE	TECH. SPEC./ APPD. DRG./ DATA SHEET/ IS:9334	TECH. SPEC./ APPD. DRG./ DATA SHEET/ IS:9334	3 <sup>RD</sup> PARTY TEST CERT.	3	- 1
9.	DESIGN VERIFICATION		MA	}}	1/TYPE TEST (CYCLE TEST)	AWWA C504/C-516 & AWWA C542	AWWA C504/C-516 & AWWA C542	TEST CERT	3/2	2 1

**2.0 INPROCESS CONTROL:-**

2.1 BODY & DISC	1 DIMENSIONS	MA	MEASURE- MENT	100%	MFG DRG	MFG DRG	INSPN. REPORT	2	--	1
-----------------	--------------	----	---------------	------	---------	---------	---------------	---	----	---

BHEL		PARTICULARS		BIDDER/VENDOR	
		NAME			
		SIGNATURE			
		DATE			

*ANUJ AWASTHI*  
Engineer, MPL

BIDDER'S/ VENDOR'S COMPANY SEAL



**QUALITY PLAN**

CUSTOMER: M/S GSECL  
VENDOR: LATER

PROJECT: 1X800 MW WANAKBORI TPS EXT. UNIT-8  
REV.00 dtd. 25-09-2015  
QP NO.: PE-QP-408-100-M016

SPEC NO.: PE-TS-408-100-M016  
SPEC. TITLE STANDARD SPEC. FOR TWO WAY  
BF VALVE FOR STEAM SERVICE

SYSTEM STEAM SERVICE

ITEM: CAST CARBON STEEL BUTTERFLY VALVE  
UPTO SIZE 2000 NB MOTORIZED

SECTION - VOLUME

SHEET 5 OF 8

S.N O.	COMPONENT/ OPERATION	CHARACTERISTICS CHECKED	CAT E-GO RY	TYPE/METH- OD OF CHECK	EXTENT OF CHECK	REFERENCE DOCUMENT	ACCEPTANCE NORMS	FORMAT OF RECORD	AGENCY	REMARKS
									P W V	

		2. SURFACE DEFECTS	CR	P.T.	100%	ASTM E165	ANSI B 16.34 APPENDIX III	INSPN. REPORT	2	1	ON MACHINED AREA ONLY.
2.2	WELDING OVERLAY DEPOSIT	WELDING PROCEDURE AND WELDER PERFORMANCE QUALIFICATION CLADDING	CR	VISUAL MECH. TESTS	100%	ASME IX	ASME IX	INSPN. REPORT	3/2	--	ONLY BHEL / CUSTOMER QUALIFIED WELDERS SHALL BE ENGAGED FOR WELDING. WPS SHALL BE SUBMITTED FOR APPROVAL.
			MA	DEPTH MEASUREMENT	100%	MFG. DWG	MFG. DWG	TEST REPORT	2	1	
			MA	SURFACE DEFECT LPI ON WELD OVERLAY AND ADJACENT AREA	100%	ASTM 165	FREE FROM POROSITY / CRACK	NDT REPORT	2	1	
2.2.1	SEAT RING	1. SUB-SURFACE DEFECTS	MA	RT/UT	100%	ASME B16.34	ASME B16.34	INSPN REPORT	3/2	2	
		2. SURFACE DEFECT	MA	LPI	100%	ASTM A165	FREE FROM CRACKS	INSPN REPORT	2	1	
2.3	BODY ( BUTT WELD ENDS)	SUB-SURFACE DEFECT INTERNAL DEFECTS	CR	MPI	100% ON BW AREA	ASTM A709	ANSI B 16.34 APPENDIX III	NDT REPORT	2	1	
			CR	RT	100% ON BW AREA	ASME B16.34	ASME B16.34	RT REPORT			RT (100%) ON BW ENDS AS PER SL. NO. 1.1 CLAUSE NO.2
2.4	SHAFT	1. DIMENSION	MA	MEASURE- MENT	100%	MFG DRG	MFG DRG	LOG BOOK	2	--	
		2.SURFACE DEFECTS	MA	P.T.	100%	ASTME165.	ANSI B 16.34 APPENDIX III	INSPN REPORT	2	1	

BHEL		PARTICULARS		BIDDER/VENDOR	
		NAME			
		SIGNATURE			
		DATE			
					BIDDER'S/ VENDOR'S COMPANY SEAL

*Anuj Awasthi*  
Engineer, MPL



**QUALITY PLAN**

SHEET 6 OF 8

CUSTOMER: LATER  
VENDOR: LATER

PROJECT : LATER  
Q.P NO. . PE-QP-392-100-M024

REV. 00 DT. 07-04-14

SPEC. NO : PE-MOU-999-100-M016  
SPEC. TITLE STANDARD SPEC. FOR TWO WAY  
BF VALVE FOR STEAM SERVICE

SYSTEM STEAM SERVICE  
ITEM: CAST CARBON STEEL BUTTERFLY VALVE  
UPTO SIZE 2000 NB MOTORIZED

SECTION - VOLUME

S.N O.	COMPONENT/ OPERATION	CHARACTERISTICS CHECKED	CAT E-GO RY	TYPE/METH- OD OF CHECK	EXTENT OF CHECK	REFERENCE DOCUMENT	ACCEPTANCE NORMS	FORMAT OF RECORD	AGENCY	REMARKS
									P W V	

3.1	VERIFICATION OF ALL PREVIOUS TESTS AND DOCUMENTS	VERIFICATION OF RECORDS	MA	---	100%	TECH SPEC	TECH SPEC	---	2 1 1	1	
3.2	TESTS (HYDRAULIC)	1. BODY TEST	CR	HYDRO TEST	100%	AWWA C-504/C-516/APPD.DRG.	NO LEAKAGE	INSP. REPORT	2 1	--	
		2. DISC STRENGTH	CR	HYDRO TEST	100%	AWWA C-504/C-516 APPD.DRG.	NO DEFORMATION/ NO STRUCTURAL DAMAGE TO DISC	INSP. REPORT	2 1	-	ONE VALVE/SIZE SHALL BE TESTED FOR TWICE THE DESIGN PRESSURE FROM BOTH SIDE OF THE VALVE IN ADDITION TO 100% TESTING IN THE NORMAL FLOW DIRECTION. NO PART OF DISC/ VALVE SHALL BE PERMANENTLY DEFORMED/ DAMAGED. DISC DEFORMATION IS MEASURED USING DIAL GAUGE AND BODY DEFORMATION BY MEASURING TAPE
		3. SEAT LEAKAGE WITH ACTUATOR (BOTH DIRECTION)	CR	HYDRO/AIR TEST	100%	AWWA C-504/C-516/APPD. DRG.	NO LEAKAGE	INSP. REPORT	2 1	-	
		4. PERFORMANCE TEST	CR	PERFORMANCE	100%	AWWA C-504/C-516*	SMOOTH OPERATION	INSP. REPORT	2 1	-	* COMPLETE VALVE ASSEMBLY ALONGWITH ACTUATOR SHALL BE SHIP OPERATED IN HORIZONTAL & VERTICAL POSITION 1) UNDER AT NO LOAD (25 CYCLES) 2) UNDER PRESSURE (CRACK OPEN 3 CYCLES) IN HORIZONTAL POSITION ONLY AND FOLLOWING SHALL BE CHECKED - OPERATING & CLOSING TIME - OPERATION OF TORQUE &

BHEL		PARTICULARS		BIDDER/VENDOR	
		NAME			
		SIGNATURE			
		DATE			

*ANUJ AWASTHI*  
*Engineer, MPL*

BIDDER'S/ VENDOR'S COMPANY SEAL



		<b>QUALITY PLAN</b>		CUSTOMER: M/S GSECL. VENDOR: LATER		PROJECT: 1X800 MW WANAKBORI TPS EXT. UNIT-8 QP NO.: PE-QP-408-100-M016 REV.00 dtd. 25-09-2015		SPEC NO.: PE-TS-408-100-M016	
		SHEET 8 OF 8	SYSTEM STEAM SERVICE	ITEM: CAST CARBON STEEL BUTTERFLY VALVE UPTO SIZE 2000 NB MOTORISED	REFERENCE DOCUMENT	ACCEPTANCE NORMS	FORMAT OF RECORD	AGENCY	REMARKS
S.N O.	COMPONENT/ OPERATION	CHARACTERISTICS CHECKED	CAT E-GO RY	TYPE/METHOD OF CHECK	EXTENT OF CHECK	MI- MINOR	MA- MEANS MAJOR	MA- MEANS MAJOR UT- ULTRA SOUND TEST MPI= MAGNETIC PARTIAL EXAMINATION RT= RADIOGRAPHIC TEST	P W V

**NOTES:-** CR- MEANS CRITICAL MA- MEANS MAJOR MI- MINOR  
 PT-PENETRATION TEST UT- ULTRA SOUND TEST MPI= MAGNETIC PARTIAL EXAMINATION RT= RADIOGRAPHIC TEST  
 1- BHEL (PURCHASER) & CUSTOMER 2- VENDOR (MAIN) 3- SUB-VENDOR OF VENDOR  
 ALL MATERIALS SHALL BE AS PER APPROVED DRGS/ DATA SHEET FOR VALVES. LATEST EDITIONS OF ALL THE ABOVE MENTIONED STANDARDS SHALL BE FOLLOWED.

\*Vendor to provide the following:

- Photographs of Valves/traps duly placed inside the wooden box just before final packing.
  - Photographs of the wooden box in which the valves have been finally packed just before dispatch.
- Clearance for dispatch of valves/traps will be given only after receiving the photos of valves/traps in satisfactory condition as mentioned in the condition stated above

<b>BHEL</b>		PARTICULARS		BIDDER/VENDOR	
		NAME			
		SIGNATURE			
		DATE			
				BIDDER'S/ VENDOR'S COMPANY SEAL	

ANUJ AWASTHI  
 Engineer, MPL



**SPECIFICATION  
FOR  
MOTORISED VALVE ACTUATOR**

SPECIFICATION NO.: PE-ID-408-145-I902

VOLUME II B

SECTION D

REV. NO. 00

DATE: 04.04.15

SHEET 1

OF 4

**Data Sheet A & B**

DATA SHEET-A  
(TO BE FILLED BY PURCHASER)

DATA SHEET-B  
(TO BE FILLED-UP BY BIDDER)

408

<b>GENERAL*</b>	* PROJECT	1X800 MW WANAKBORI TPS EXT. UNIT-8	
	OFFER REFERENCE		
	* TAG NO. SERVICE	EXV-31 & EXV-32	
	* DUTY	<input checked="" type="checkbox"/> ON / OFF <input type="checkbox"/> INCHING	
	* LINE SIZE (inlet/outlet): MATERIAL		
	* VALVE TYPE	<input type="checkbox"/> GLOBE <input type="checkbox"/> GATE <input type="checkbox"/> REG. GLOBE <input checked="" type="checkbox"/> BUTTERFLY	
	* OPENING / CLOSING TIME	50-90 SEC	
	* WORKING PRESSURE		
	AMBIENT CONDITION	SHALL BE SUITABLE FOR CONTINUOUS OPERATION UNDER AN AMBIENT TEMP. OF 0-55 DEG C AND RELATIVE HUMIDITY OF 0-95%	
	VALVE SEAT TEST PRESS	BIDDER TO SPECIFY	
REQUIRED VALVE TORQUE	BIDDER TO SPECIFY		
ACTUATOR RATED TORQUE	BIDDER TO SPECIFY		
<b>CONSTRUCTION AND SIZING</b>	CONSTRUCTION	TOTALLY ENCLOSED, WEATHER PROOF, IPW:55	
	MECHANICAL POSITION INDICATOR	TO BE PROVIDED FOR 0-100% TRAVEL	
	BEARINGS	DOUBLE SHIELDED, GREASE LUBRICATED ANTI-FRICTION.	
	GEAR TRAIN FOR LIMIT SWITCH/TORQUE SWITCH OPERATION	METAL (NOT FIBRE GEARS). SELF-LOCKING TO PREVENT DRIFT UNDER TORQUE SWITCH SPRING PRESSURE WHEN MOTOR IS DE-ENERGIZED.	
	SIZING	OPEN/CLOSE AT RATED SPEED AGAINST DESIGNED DIFFERENTIAL PRESSURE AT 85% OF RATED VOLTAGE. FOR ISOLATING SERVICE THREE SUCCESSIVE OPEN-CLOSE OPERATIONS OR 15 MINS. WHICHEVER IS HIGHER FOR <b>INCHING SERVICE - 150 STARTS/HR MINIMUM &amp; FOR REGULATING SERVICE - 600 STARTS/HR MINIMUM.</b>	
<b>HANDWHEEL</b>	* REQUIRED	<input checked="" type="checkbox"/> YES <input type="checkbox"/> NO	
	* ORIENTATION	<input type="checkbox"/> TOP MOUNTED <input type="checkbox"/> SIDE MOUNTED	
	*TO DISENGAGE AUTOMATICALLY DURING MOTOR OPERATION.		
<b>ELECTRIC ACTUATOR</b>	ACTUATOR MAKE/MODEL	BIDDER TO SPECIFY	
	MOTOR MAKE / MODEL / TYPE / RATING (KW)	BIDDER TO SPECIFY	
	@ MOTOR TYPE	SQUIRREL CAGE INDUCTION MOTOR, STARTING CURRENT LIMITED TO SIX TIMES THE RATED CURRENT- <b>INCLUSIVE OF I.S. TOLERANCE</b>	
	ACTUATOR APPLICABLE WIRING DIAGRAM	<input checked="" type="checkbox"/> ENCLOSED (BIDDER TO CONFIRM) A: <input type="checkbox"/> DRG. NO. 3-V-MISC-24227 R00 B: <input type="checkbox"/> DRG. NO. 3-V-MISC-24550 R00 C: <input type="checkbox"/> DRG. NO. 3-V-MISC-24283 R00 D: <input checked="" type="checkbox"/> DRG. NO. 4-V-MISC-90271 R11 E: <input type="checkbox"/> For Thyristor based Integral starter, Bidder/Vendor to furnish wiring diagram	
	COLOUR SHADE	<input type="checkbox"/> BLUE (RAL 5012) <input type="checkbox"/> ..... (TO BE DECIDED BY BHEL DURING DETAIL ENGG.)	
	PAINT TYPE (## Refer Notes)	<input type="checkbox"/> ENAMEL <input type="checkbox"/> EPOXY <input type="checkbox"/> ..... (TO BE DECIDED BY BHEL DURING DETAIL ENGG.)	
	SHAFT RPM	BIDDER TO SPECIFY	
	OLR SET VALUE	BIDDER TO SPECIFY	
	@ STARTING / FULL LOAD CURRENT	BIDDER TO SPECIFY	
	NO. OF REV FOR FULL TRAVEL	BIDDER TO SPECIFY	



**SPECIFICATION  
FOR  
MOTORISED VALVE ACTUATOR**

SPECIFICATION NO.: PE-ID-408-145-I902

VOLUME II B

SECTION D

REV. NO. 00

DATE: 04.04.15

SHEET 2

OF 4

**Data Sheet A & B**

DATA SHEET-A  
(TO BE FILLED BY PURCHASER)

DATA SHEET-B  
(TO BE FILLED-UP BY BIDDER)

408

	@ PWR SUPP TO MTR / STARTER	415V, 3PH, AC		
	@ CONTROL VOLTAGE REQUIREMENT	TO BE DERIVED FROM THE POWER SUPPLY TO THE STARTER <input type="checkbox"/> 230 V <input checked="" type="checkbox"/> 110 V		
	@ ENCLOSURE CLASS OF MOTOR	<input checked="" type="checkbox"/> IP 65 <input type="checkbox"/> FLAME PROOF		
	@ INSULATION CLASS	CLASS-F TEMP. RISE LIMITED TO CLASS-B		
	@ WINDING TEMP PROTECTION	<input checked="" type="checkbox"/> THERMOSTAT (3 Nos.,1 IN EACH PHASE) <input checked="" type="checkbox"/> ---THERMOSTAT- 1 NO+1 NC CONTACT -----		
	SINGLE PHASE / WRONG PHASE SEQUENCE PROTECTION	REQUIRED		
<b>INTEGRAL STARTER</b>	INTEGRAL STARTER	<input type="checkbox"/> REQUIRED <input checked="" type="checkbox"/> NOT REQUIRED		
	TYPE OF SWITCHING DEVICE	<input type="checkbox"/> CONTACTORS <input type="checkbox"/> THYRISTORS		
	TYPE	<input type="checkbox"/> CONVENTIONAL <input type="checkbox"/> SMART (NON-INTRUSIVE)		
	<b>IF SMART</b>			
	a) SERIAL LINK INTERFACE	<input type="checkbox"/> INTEGRAL <input type="checkbox"/> FIELD MOUNTED		
	b) SERIAL LINK PROTOCOL	<input type="checkbox"/> FOUNDATION FIELD-BUS <input type="checkbox"/> PROFI-BUS <input type="checkbox"/> DEVICE NET <input type="checkbox"/> .....		
	c) SERIAL LINK MEDIA	<input type="checkbox"/> TWISTED PAIR Cu-CBL <input type="checkbox"/> CO-AXIAL Cu-CBL <input type="checkbox"/> OFC		
	d) HAND HELD PROGRAMMER	<input type="checkbox"/> REQUIRED <input type="checkbox"/> NOT REQUIRED		
	e) TYPE OF HAND HELD PROGRAMMER	<input type="checkbox"/> BLUETOOTH <input type="checkbox"/> INFRARED <input type="checkbox"/> .....		
	f) MASTER STATION	<input type="checkbox"/> REQUIRED <input type="checkbox"/> NOT REQUIRED		
	g) MASTER STN INTRFACE WITH DCS	<input type="checkbox"/> MODBUS <input type="checkbox"/> TCP/IP		
	h) DETAILS OF SPECIAL CABLE	<input type="checkbox"/> ENCLOSED <input type="checkbox"/> NOT REQUIRED		
	STEP DOWN CONT. TRANSFORMER	<input type="checkbox"/> REQUIRED		
	OPEN / CLOSE PB	<input type="checkbox"/> REQUIRED <input type="checkbox"/> NOT REQUIRED		
	STOP PB	<input type="checkbox"/> REQUIRED <input type="checkbox"/> NOT REQUIRED		
	INDICATING LAMPS	<input type="checkbox"/> REQUIRED <input type="checkbox"/> NOT REQUIRED		
	LOCAL REMOTE S/S	<input type="checkbox"/> REQUIRED <input type="checkbox"/> NOT REQUIRED		
STATUS CONTACTS FOR MONITORING	<input type="checkbox"/> REQUIRED <input type="checkbox"/> NOT REQUIRED			
INTEGRAL STARTER DISTURBED SIGNAL	REQUIRED (O/L RELAY OPERATED, CONT./POWER SUPPLY FAILED, S/S IN LOCAL, TORQUE SWITCH OPTD. MID WAY)			
<b>INTERPOSING RELAY/OPTO COUPLER</b> (Applicable for integral Starter)	TYPE OF ISOLATING DEVICE	<input type="checkbox"/> INTERPOSING RELAY <input type="checkbox"/> OPTO COUPLER <input type="checkbox"/> EITHER		
	QUANTITY	<input type="checkbox"/> 2 NOs. <input type="checkbox"/> 3 NOs.		
	DRIVING VOLTAGE	<input checked="" type="checkbox"/> 20.5 – 24V DC <input type="checkbox"/> _____ V DC		
	DRIVING CURRENT	<input checked="" type="checkbox"/> 125mA MAX <input type="checkbox"/> _____ mA MAX		
	LOAD RESISTANCE	<input checked="" type="checkbox"/> > 192 ohms - <25 k ohms <input type="checkbox"/> > _____ ohms - < _____ ohms		
<b>TORQUE SWITCH</b> (Not Applicable for Smart Actuator) <b>(\$\$ Refer Notes)</b>	MFR & MODEL NO.	BIDDER TO SPECIFY		
	OPEN / CLOSE	<input checked="" type="checkbox"/> 1 No. <input type="checkbox"/> 2Nos. / <input checked="" type="checkbox"/> 1 No. <input type="checkbox"/> 2Nos		
	CONTACT TYPE	2 NO + 2 NC		
	RATING	5A 240V AC AND 0.5A 220V DC		
	CALIBRATED KNOBS(OPEN&CLOSE TS)	REQUIRED FOR SETTING DESIRED TORQUE		
	ACCURACY	+3% OF SET VALUE		



**SPECIFICATION  
FOR  
MOTORISED VALVE ACTUATOR**

SPECIFICATION NO.: PE-ID-408-145-I902

VOLUME II B

SECTION D

REV. NO. 00

DATE: 04.04.15

SHEET 3

OF 4

**Data Sheet A & B**

DATA SHEET-A  
(TO BE FILLED BY PURCHASER)

DATA SHEET-B  
(TO BE FILLED-UP BY BIDDER)

408

<b>LIMIT SWITCH</b> (Not Applicable for Smart Actuator) (\$\$ Refer Notes)	MFR & MODEL NO.	BIDDER TO SPECIFY		
	OPEN : INT : CLOSE	<input type="checkbox"/> 1 No. <input checked="" type="checkbox"/> 2 Nos.	2 Nos. (ADJ.)	<input type="checkbox"/> 1 No. <input checked="" type="checkbox"/> 2Nos.
	CONTACT TYPE	2 NO + 2 NC		
	RATING (AC / DC)	5A 240V AC AND 0.5A 220V DC		

<b>POSITION TRANSMITTER</b>	POSITION TRANSMITTER (For inching duty & other specific applications)	<input checked="" type="checkbox"/> REQUIRED <input type="checkbox"/> NOT REQUIRED
	MFR & MODEL NO.	BIDDER TO SPECIFY
	TYPE	<input checked="" type="checkbox"/> ELECTRONIC (2 WIRE) R/I CONVERTER <input type="checkbox"/> ELECTRONIC (2 WIRE) CONTACTLESS
	SUPPLY	<input checked="" type="checkbox"/> 24V DC <input type="checkbox"/> .....
	OUTPUT	<input checked="" type="checkbox"/> 4-20mA
	ACCURACY	$\pm$ 1% FS
<b>SPACE HEATER</b>	@SPACE HEATER	REQUIRED
	@ POWER SUPPLY (NON INTEGRAL)	230V AC, 1 PH., 50 Hz
	@ POWER SUPPLY (INTEGRAL)	BIDDER TO SPECIFY
	@ RATING	decided as per load data received tender stage
<b>TERMINAL BOX</b>	ACTUATOR/MOTOR TERMINAL BOX	REQUIRED
	ENCL CLASS ACTUATOR/MOTOR T.B.	@ <input type="checkbox"/> IP 68                      @ <input type="checkbox"/> .....
	@ EARTHING TERMINAL	REQUIRED
	PLUG & SOCKET(9 PIN) (FOR COMMD, LS/TS FEED BACK, PoT)	<input type="checkbox"/> REQUIRED <input type="checkbox"/> NOT REQUIRED <input type="checkbox"/> 2 NOS. <input type="checkbox"/> .....
<b>CABLE GLANDS</b>	@ POWER CABLE GLAND	SIZE: decided as per load data received tender stage
	@ SPACE HEATER CABLE GLAND	3C-2.5 sq mm
	OTHER CONTROL CABLE GLANDS-1	<input type="checkbox"/> 1No. for BFV of CW PUMP(Cable size 2Px1.5mm <sup>2</sup> )
	OTHER CONTROL CABLE GLANDS-2	12C- 2.5 sq mm cable



**SPECIFICATION  
FOR  
MOTORISED VALVE ACTUATOR**

SPECIFICATION NO.: PE-ID-408-145-I902	
VOLUME	II B
SECTION	D
REV. NO.	00
DATE:	04.04.15
SHEET	4 OF 4

**Data Sheet A & B**

DATA SHEET-A (TO BE FILLED BY PURCHASER)	DATA SHEET-B (TO BE FILLED-UP BY BIDDER)
---	---

408

<b>WEIGHT</b>	TOTAL WEIGHT (ACTUATOR + ACCESSORIES)	BIDDER TO SPECIFY	_____ Kg.
---------------	---------------------------------------	-------------------	-----------

**NOTES:**

1. **SCOPE:** DESIGN, MANUFACTURE, INSPECTION, TESTING AND DELIVERY TO SITE OF ELECTRIC ACTUATOR FOR INCHING OR OPEN / CLOSE DUTY.
  2. **CODES & STANDARDS:** DESIGN AND MATERIALS USED SHALL COMPLY WITH THE RELEVANT LATEST NATIONAL AND INTERNATIONAL STANDARD. AS A MINIMUM, THE FOLLOWING STANDARDS SHALL BE COMPLIED WITH:  
IS-9334, IS-2147, IS-2148, IS-325, IS-2959, IS-4691 AND IS-4722
  3. TEMPERATURE RISE SHALL BE RESTRICTED TO 70 DEG. C FOR AMBIENT TEMPERATURE OF 50 DEG C.
  4. CABLE GLANDS OF DOUBLE COMPRESSION TYPE, BRASS MATERIAL SHALL BE PROVIDED.
  5. THE TORQUE SWITCHES SHALL BE PROVIDED WITH MECHANICAL LATCHING DEVICE TO PREVENT OPERATION WHEN UNSEATING FROM THE END POSITIONS. THE LATCHING DEVICE SHALL UNLATCH AS SOON AS THE VALVE LEAVES THE END POSITION. IF SUCH PROVISION IS NOT POSSIBLE, THE TORQUE SWITCHES SHALL BE BYPASSED BY END-POSITION LIMIT SWITCHES WHICH OPENS ON VALVE LEAVING END POSITION. THESE LIMIT SWITCHES ARE ADDITIONAL TO THE NUMBER OF LIMIT SWITCHES SPECIFIED ELSEWHERE.
  6. THE MOTOR SHALL OPERATE SATISFACTORILY UNDER THE +/- 10% SUPPLY VOLTAGE VARIATION AT RATED FREQUENCY, -5% TO +3% VARIATION IN FREQUENCY AT RATED SUPPLY VOLTAGE, SIMULTANEOUS VARIATION IN VOLTAGE & FREQUENCY THE SUM OF ABSOLUTE PERCENTAGE NOT EXCEEDING 10%.
  7. THE MOTOR SHALL BE SUITABLE FOR DIRECT ON LINE STARTING.
  8. CANOPY FOR OUTDOOR SERVICES SHALL BE PROVIDED.
- \$\$ TORQUE SWITCH & LIMIT SWITCH SHALL ACT INDEPENDENT OF EACH OTHER. TANDEM OPERATION IS NOT ACCEPTABLE.**
- ## EPOXY PAINT IS RECOMMENDED FOR COASTAL AREAS.**

NAME SIGNATURE DATE	<b>PREPARED BY</b>	<b>CHECKED BY</b>	<b>APPROVED BY</b>	<b>VENDOR COMPANY SEAL</b>
				NAME
				SIGNATURE
				DATE

NOTES\* = TO BE FILLED BY MPL (LEAD AGENCY). @ = TO BE FILLED BY ES



	<b>COMPLIANCE SHEET BUTTERFLY VALVE-STEAM SERVICE</b>	SPECIFICATION NO. PE-TS-408-100-M016	
		SECTION : II	
		REV. NO.: 00	DATE: 15.06.2016
		Sheet 1 of 1	

**The bidder shall sign and return a copy of this compliance sheet along with his offer, indicating his compliance to the points specified herein:**

A) **Technical Details:** Bidder to tick whichever is applicable.

1.	Specific Technical requirements of Section-A	<b>Accepted</b>	<b>Not Accepted</b>
2.	Technical requirements as per Data sheet-A of Section-B	<b>Accepted</b>	<b>Not Accepted</b>
3.	Quality Plan	<b>Accepted</b>	<b>Not Accepted</b>

- B) The scope of supply, technical details, construction features, design parameters etc. shall be as per technical specification & there are no exclusions/ deviations with regard to same.
- C) QP/ test procedures shall be submitted in the event of order based on the guidelines given in the specification & QP enclosed therein. QP will be subject to BHEL/Customer approval in the event of order & customer hold points for inspection/ testing shall be marked in the QP at the contract stage. Inspection/ testing shall be witnessed as per same apart from review of various test certificates/ Inspection records etc. The charges for 3rd party inspection (Lloyds, TUV or equivalent) for foreign bidders shall be included in the base price of the equipment by the bidder. This 3rd party inspection agency shall be approved by BHEL and will be decided in contract stage.
- D) All drawings/data – sheets etc. to be submitted during contract shall be subject to BHEL/Customer review/ approval.
- E) GA drawings, as submitted with offer at tender stage are for reference purpose only and shall be subject to approval during contract stage.
- F) There are no other deviations with respect to specification other than those furnished in the ‘Schedule of Deviations’.
- G) The offered materials should be either equivalent or superior to those specified. Also for components where material is not specified, the material used shall be suitable for intended duty.
- H) The commissioning spares (if any) are supplied on ‘As Required Basis’ & prices for same shall be quoted in the price bid format. If the bidder has not quoted for commissioning spares at tender stage and if the same are actually required during commissioning, then the same shall be supplied by bidder without any cost to BHEL.
- I) Any special tools & tackles, if required, shall be in bidder’s scope

PARTICULARS OF BIDDER / AUTHORISED REPRESENTATIVE				
NAME	DESIGNATION	SIGNATURE	DATE	COMPANY SEAL