

**NEYVELI LIGNITE CORPORATION LIMITED
2x500 MW NEYVELI NEW THERMAL POWER PROJECT
(NNTPP)**

NEYVELI, TAMIL NADU, INDIA

VOLUME – IIB

**TECHNICAL SPECIFICATION
FOR
*CABLE TRAYS & ACCESSORIES***

**SPECIFICATION NO : *PE-TS-400/402-507-E021*
REVISION : 0**



**BHARAT HEAVY ELECTRICALS LIMITED
POWER SECTOR
PROJECT ENGINEERING MANAGEMENT
NOIDA, UP (INDIA) – 201301**



**TECHNICAL SPECIFICATION FOR
CABLE TRAYS & ACCESSORIES**

SPECIFICATION NO. PE-TS- 400/402-507-E021

VOLUME II B

SECTION ---

REVISION 0

DATE: 15.05.2014

SHEET 1 OF 1

CONTENTS

Sl. No.	DESCRIPTION	NO. OF SHEETS
1.0	INSTRUCTIONS TO BIDDERS	01
2.0	PREAMBLE	01
3.0	SECTION – ‘A’ (SCOPE OF ENQUIRY)	02
4.0	<i>SECTION – ‘B’ (PROJECT INFORMATION)</i>	<i>03</i>
5.0	SECTION – ‘C’ (SPECIFIC TECHNICAL REQUIREMENTS)	<i>02</i>
5.1	<i>ANNEXURE-I (BOQ CUM PRICE SCHEDULE)</i>	<i>06</i>
5.2	<i>ANNEXURE-II (LIST OF DRAWINGS /DOCUMENTS TO BE SUBMITTED BY SUCCESSFUL BIDDER)</i>	01
5.3	<i>ANNEXURE-III (VENDOR DRAWING/DOCUMENT SCHEDULE)</i>	01
6.0	SECTION- ‘D’	
6.1	STANDARD TECHNICAL SPECIFICATION	03
6.2	DATA SHEET -A	02
7.0	STANDARD QUALITY PLAN	04
8.0	TYPICAL DETAILS OF CABLE TRAYS & ACCESSORIES (DRAWING NO. PE-DG-400-507-E005)	11

IT IS CONFIRMED THAT OUR TECHNICAL OFFER COMPLIES WITH THE SPECIFICATION IN TOTO & THAT THERE ARE NO TECHNICAL DEVIATIONS.

BIDDER’S STAMP & SIGNATURE



**TECHNICAL SPECIFICATION FOR
CABLE TRAYS & ACCESSORIES**

SPECIFICATION NO. PE-TS-400/402-507-E021	
VOLUME II B	
SECTION ---	
REVISION 0	DATE:15.05.2014
SHEET 1	OF 1

INSTRUCTIONS TO BIDDERS FOR PREPARING TECHNICAL OFFER

1. Two signed and stamped copies of the following shall be furnished by all bidders as technical offer :
 - a. Unpriced Price Schedule (Annexure-I: BOQ, as enclosed with the specification).
 - b. A copy of this sheet ("Instructions to Bidders for Preparing Technical Offer").
 - c. A copy of previous sheet ("Contents").
2. No other technical submittal such as copies of type test certificates, data sheets, write-up, drawing, technical literature, etc. is required during tender stage. Any such submission, even if made, shall not be considered as part of offer.
3. No comments/ additions/ deletions shall be made by the bidder on the signed & stamped copy of the specification. Any such changes made by the bidder shall not be considered.
4. Confirmations/ comments (if any) regarding delivery schedules shall be furnished as part of the commercial offer. Any reference in the technical offer / covering letter shall not be considered by BHEL.
5. Any comments/ clarifications on technical/ inspection requirements furnished as part of bidder's covering letter shall not be considered by BHEL, and bidder's offer shall be construed to be in conformance with the specification.
6. Any changes made by the bidder in the price schedule with respect to the item description/ quantities, notes etc. from those given in Annexure-I of specification [Bill Of Quantities] shall not be considered (i.e., technical description, quantities, notes etc. as per specification shall prevail).

BIDDER'S STAMP & SIGNATURE



**TECHNICAL SPECIFICATION FOR
CABLE TRAYS & ACCESSORIES**

SPECIFICATION NO. PE-TS-400/402-507-E021	
VOLUME II B	
SECTION ---	
REVISION 0	DATE: 15.05.2014
SHEET 1 OF 1	

PREAMBLE

1.0 The tender document contains two (2) volumes. The bidder shall meet the requirements of all the two volumes.

1.1 Volume-I (CONDITIONS OF CONTRACT)

This consists of four parts as below:-

- Volume-IA : This part contains instructions to bidders for making bids to BHEL.
- Volume-IB : This part contains general commercial conditions of the tender & includes provision that vendor is responsible for the quality of item supplied by their sub-vendors.
- Volume-IC : This part contains special conditions of contract.
- Volume-ID : This part contains commercial conditions for erection & commissioning site work, as applicable.

1.2 Volume-II TECHNICAL SPECIFICATIONS

Technical requirements are stipulated in Volume-II which comprises of :-

- Volume-IIA : General Technical Conditions
- Volume-IIB : Technical Specification including Drawings, if any.

1.2.1 Volume-IIB

This volume is sub-divided into following sections:-

- Section-A : This section outlines the scope of enquiry.
- Section-B : This section provides "Project Information".
- Section-C : This section indicates technical requirements specific to the contract, not covered in Section-D.
- Section-D : This section comprises of technical specifications of equipments complete with data sheet A.

Data Sheet - A specifies data and other requirements pertaining to the Equipment.

2.0 The requirements mentioned in Section-C / Data Sheets-A of section-D shall prevail and govern in case of conflict between the same and the corresponding requirements mentioned in the descriptive portion in Section-D.



TECHNICAL SPECIFICATION FOR
CABLE TRAYS & ACCESSORIES

SPECIFICATION NO.
PE-TS- 400/402-507-E021

VOLUME II B

SECTION A

REVISION 0

DATE: 15.05.2014

SHEET 1 OF 2

SECTION – A

SCOPE OF ENQUIRY



TECHNICAL SPECIFICATION FOR
CABLE TRAYS & ACCESSORIES

SPECIFICATION NO.
PE-TS- 400/402-507-E021

VOLUME II B

SECTION A

REVISION 0

DATE: 15.05.2014

SHEET 2 OF 2

SCOPE OF ENQUIRY

- 1.0 This specification covers the Design, Manufacture, Inspection and Testing at Manufacturer's works, proper packing and delivery to site of **Cable Trays & Accessories** as mentioned in different sections of this specification for 2x500 MW NEYVELI NEW THERMAL POWER PROJECT at Neyveli, Tamil Nadu, India
- 2.0 It is not the intent to specify herein all the details of design & manufacture. However, the equipment shall conform in all respects to high standards of design engineering and workmanship and shall be capable of performing in continuous commercial operation at site conditions.
- 3.0 The general terms and conditions, instructions to bidders and other attachment referred to elsewhere are hereby made part of the tender specification.
- 4.0 The bidder shall be responsible for and governed by all requirements stipulated hereinafter.
- 5.0 Bidder shall confirm total compliance to the specification without any deviations from technical/quality assurance requirements stipulated.
- 6.0 The documents shall be in English Language and MKS system of units.



TECHNICAL SPECIFICATION FOR
CABLE TRAYS & ACCESSORIES

SPECIFICATION NO. PE-TS-400/402-507-
E021

VOLUME NO. : II-B

SECTION : B

REV NO. : 0 DATE : 15.05.2014

SHEET : 1 OF 3

SECTION - B

PROJECT INFORMATION



SALIENT FEATURES OF THE SITE & GENERAL PROJECT INFORMATION

1.1 Introduction

The project site at Neyveli has distinct location advantages, being at pit-head distance from the source of lignite supply from Mines, making it convenient for transportation of lignite by belt conveyor. Water source is readily available from the nearby mines lake. Besides, other infrastructure such as access road, railway connection etc, already exist.

1.2 Power Plant Site

The power plant site is located at Neyveli, opposite to the now defunct Fertilizer and Briquetting & Carbonization Plant, near TPS-I Expansion and TPS-II.

1.3 Project & Site Information

- | | | |
|------------------------------------|---|--|
| (i). Owner / Purchaser | : | Neyveli Lignite Corporation Limited (NLC Ltd), Neyveli, Cuddalore District, Tamil Nadu State, India |
| (ii). Consultant | : | Lahmeyer International (India) Pvt. Ltd (LII), Gurgaon, NCR, India. |
| (iii). Project Title | : | 2x500 MW Neyveli New Thermal Power Project (NNTPP) |
| (iv). Location | : | 200 kms south of Chennai and 50 kms south-west of Cuddalore |
| (v). Latitude | : | 11° 34' 00" N to 11° 35' 00" N |
| (vi). Longitude | : | 79° 26' 00" E to 79° 27' 00" E |
| (vii). Elevation above MSL | : | (+) 67 m |
| (viii). Nearest Railway Station | : | Neyveli, |
| (ix). Nearest Sea Port | : | Chennai, at a distance of 200 km |
| (x). Nearest Airport | : | Chennai, at a distance of 200 km |
| (xi). Road Access/Approach to Site | : | Connected by Chennai-Thanjavur NH 45C road and state highway connecting Cuddalore - Virudhachalam via Neyveli. Both NH and state high way roads are well connected to NLC township roads. The approach road is approximately 15 kms from Chennai-Thanjavur NH - 45C road |
| (xii). Site Meteorological Data | : | |
| • Max ambient temperature | : | 42.8° C |
| • Min Ambient Temperature | : | 26.9° C |





- Wet bulb temp : 29° C
- Max. Relative Humidity : 92 % in the month of September
- Min. Relative Humidity : 23 % in the month of May
- Rainfall : About 1265.7 mm annually (average)
- Wind direction : South West to North East direction
- Wind Speed : 97.2 km/hr (maximum recorded)
4.3 km/hr (average wind speed)
- Seismicity : As per IS: 1893 (part 4) (Zone-II)
Importance factor: 1.75.





TECHNICAL SPECIFICATION FOR
CABLE TRAYS & ACCESSORIES

SPECIFICATION NO.
PE-TS-400/402-507-E021

VOLUME II B

SECTION C

REVISION 0

DATE: 15.05.2014

SHEET 1 OF 2

SECTION -C

SPECIFIC TECHNICAL REQUIREMENTS

	TECHNICAL SPECIFICATION FOR CABLE TRAYS & ACCESSORIES	SPECIFICATION NO. PE-TS-400/402-507-E021	
		VOLUME II B	
		SECTION C	
		REVISION 0	DATE: 15.05.2014
		SHEET 2 OF 2	

1.0 SCOPE OF ENQUIRY

- 1.1 This enquiry covers the supply of **Cable Trays & Accessories** conforming to this specification.
- 1.2 General technical requirements of the Cable Trays & Accessories are indicated in Section-D. Project specific technical/ quality requirements / changes are listed in Section-C.
- 1.3 The stipulations of Section-C, followed by those of Data Sheet-A shall prevail in case of any conflict between the stipulations of Section-C, Data Sheet - A & Section-D.

2.0 BILL OF QUANTITIES:

- 2.1 Quantity requirements shall be as per **Annexure-I (Bill of Quantities (BOQ))** enclosed.
- 2.2 Number of coupler plates, washers, nuts & bolts to be supplied by vendor shall be as per **Data Sheet-A**.

3.0 SPECIFIC REQUIREMENTS:

3.1 Technical:

S. No.	Reference clause No. of Section D (if any)	Specific Requirement/ Change
1	Clause no. 4.1	Quality plan number shall be read as PE-QP-999-507-E005 instead of PED-507-00-Q-005/04
2	QP's (PE-QP-999-507-E005) Remarks column at S.no. 3.1 (3) Rigidity	"600MM wide cable tray to be tested" shall be read as "All sizes of cable tray shall be tested".

3.2 Quality/ Inspection:

S. No.	Reference clause No. of Section D (if any)	Specific Requirement/ Change

	TECHNICAL SPECIFICATION FOR CABLE TRAY & ACCESSORIES (SG PACKAGE)	SPECIFICATION NO. PE-TS-400/402-507-E021	
		VOLUME IIB	
		SECTION - C	
		REVISION 0	DATE:- 15.05.2014
		SHEET	

ANNEXURE - I (SG PACKAGE)

(BOO-CUM-PRICE SCHEDULE FOR CABLE TRAYS & ACCESSORIES)

Sr. No.	ITEM CODE	ITEM DESCRIPTION	UNIT	ORDER QTY.	LOT-1 QTY.	UNIT PRICE (EX WORKS) Rs.	TOTAL PRICE (EX WORKS) Rs.
1.0		HOT DIP GALVANISED LADDER TYPE CABLE TRAY COMPLETE WITH COUPLER PLATES, FASTENERS, CLAMPS AND FIXING HARDWARES ETC.					
a)	507-21101-A	CABLE TRAY 2 MM THICK- LADDER TYPE 150W	MTR	2805	1965		
b)	507-21102-A	CABLE TRAY 2 MM THICK- LADDER TYPE 300W	MTR	11825	8280		
c)	507-21103-A	CABLE TRAY 2 MM THICK- LADDER TYPE 450W	MTR	1018	650		
d)	507-21104-A	CABLE TRAY 2 MM THICK- LADDER TYPE 600W	MTR	20900	14630		
2.0		HOT DIP GALVANISED PERFORATED TYPE CABLE TRAY COMPLETE WITH COUPLER PLATES, FASTENERS, CLAMPS AND FIXING HARDWARES ETC.					
a)	507-21109-A	CABLE TRAY 2 MM THICK- PERFORATED TYPE 150W	MTR	1430	1000		
b)	507-21110-A	CABLE TRAY 2 MM THICK- PERFORATED TYPE 300W	MTR	5335	3735		
c)	507-21111-A	CABLE TRAY 2 MM THICK- PERFORATED TYPE 450W	MTR	358	230		
d)	507-21112-A	CABLE TRAY 2 MM THICK- PERFORATED TYPE 600W	MTR	6160	4320		
3.0		HOT DIP GALVANISED CABLE TRAY ACCESSORIES					
3.1		LADDER TYPE HORIZONTAL 90 DEG. BEND-600mm RADIUS					
a)	507-21117-A	LAD HOR 90DEG BEND 2 MM THICK 600 RAD 300W	NOS	64	41		
b)	507-21119-A	LAD HOR 90DEG BEND 2 MM THICK 600 RAD 600W	NOS	439	280		
3.2		LADDER TYPE VERTICAL 90 DEG. BEND-600mm RADIUS (INSIDE)					
a)	507-21123-A	LAD VER 90DEG BEND 2 MM THICK 600 RAD-INSIDE 300W	NOS	146	94		
b)	507-21125-A	LAD VER 90DEG BEND 2 MM THICK 600 RAD-INSIDE 600W	NOS	81	52		
3.3		LADDER TYPE VERTICAL 90 DEG. BEND-600mm RADIUS (OUTSIDE)					
a)	507-21129-A	LAD VER 90DEG BEND 2 MM THICK 600 RAD-OUTSIDE 300W	NOS	154	98		
b)	507-21131-A	LAD VER 90DEG BEND 2 MM THICK 600 RAD-OUTSIDE 600W	NOS	65	42		
3.4		LADDER TYPE TEES-600mm RADIUS					
a)	507-21135-A	LAD TEES 600MM RADIUS 2 MM THICK 300W	NOS	5	3		
b)	507-21136-A	LAD TEES 600MM RADIUS 2 MM THICK 450W	NOS	7	5		
c)	507-21137-A	LAD TEES 600MM RADIUS 2 MM THICK 600W	NOS	717	457		

	<p style="text-align: center;">TECHNICAL SPECIFICATION FOR CABLE TRAY & ACCESSORIES (SG PACKAGE)</p>	SPECIFICATION NO. PE-TS-400/402-507-E021	
		VOLUME IIB	
		SECTION - C	
		REVISION 0	DATE:- 15.05.2014
		SHEET	

NOTES:

- 1 The quantities will be released for manufacture in more than one lot. Lot-I quantities, which are indicated above, shall be released for manufacture along with LOI.
- 2 Manufacturing of Lot-I quantities shall be done after the approval of technical and quality documentation, and supply of same shall be completed within four months of date of approval of documents.
- 3 Subsequent lots shall be cleared for manufacture based on progress of engineering and site requirements. A lead-time of three months shall be given for completion of supply of each lot from the date of clearance of the quantities.
- 4 The total quantity variation shall be limited from -30 % to +30 % of the total contract value derived on the basis of the Order Quantities.
- 5 Raw materials: - Steel shall be procured from SAIL/TISCO/RINL/BHUSAN/JINDAL STEEL/JINDALISPAT/ESSAR/LLOYD/ IISCO/ authorised re-rollers of SAIL.
- 6 The number of coupler plates, washers, bolts & nuts shall be as per Data Sheet- A attached with the specification.

	TECHNICAL SPECIFICATION FOR CABLE TRAY & ACCESSORIES (TG PACKAGE)	SPECIFICATION NO. PE-TS-400/402-507-E021	
		VOLUME IIB	
		SECTION - C	
		REVISION 0	DATE:- 15.05.2014
		SHEET	

ANNEXURE - I (TG PACKAGE)

(BOO-CUM-PRICE SCHEDULE FOR CABLE TRAYS & ACCESSORIES)

Sr. No.	ITEM CODE	ITEM DESCRIPTION	UNIT	ORDER QTY.	LOT-1 QTY.	UNIT PRICE (EX WORKS) Rs.	TOTAL PRICE (EX WORKS) Rs.
1.0		HOT DIP GALVANISED LADDER TYPE CABLE TRAY COMPLETE WITH COUPLER PLATES, FASTENERS, CLAMPS AND FIXING HARDWARES ETC.					
a)	507-21101-A	CABLE TRAY 2 MM THICK- LADDER TYPE 150W	MTR	2295	1610		
b)	507-21102-A	CABLE TRAY 2 MM THICK- LADDER TYPE 300W	MTR	9675	6750		
c)	507-21103-A	CABLE TRAY 2 MM THICK- LADDER TYPE 450W	MTR	832	590		
d)	507-21104-A	CABLE TRAY 2 MM THICK- LADDER TYPE 600W	MTR	17100	11970		
2.0		HOT DIP GALVANISED PERFORATED TYPE CABLE TRAY COMPLETE WITH COUPLER PLATES, FASTENERS, CLAMPS AND FIXING HARDWARES ETC.					
a)	507-21109-A	CABLE TRAY 2 MM THICK- PERFORATED TYPE 150W	MTR	1170	820		
b)	507-21110-A	CABLE TRAY 2 MM THICK- PERFORATED TYPE 300W	MTR	4365	3055		
c)	507-21111-A	CABLE TRAY 2 MM THICK- PERFORATED TYPE 450W	MTR	292	205		
d)	507-21112-A	CABLE TRAY 2 MM THICK- PERFORATED TYPE 600W	MTR	5040	3530		
3.0		HOT DIP GALVANISED CABLE TRAY ACCESSORIES					
3.1		LADDER TYPE HORIZONTAL 90 DEG. BEND-600mm RADIUS					
a)	507-21117-A	LAD HOR 90DEG BEND 2 MM THICK 600 RAD 300W	NOS	52	26		
b)	507-21119-A	LAD HOR 90DEG BEND 2 MM THICK 600 RAD 600W	NOS	359	177		
3.2		LADDER TYPE VERTICAL 90 DEG. BEND-600mm RADIUS (INSIDE)					
a)	507-21123-A	LAD VER 90DEG BEND 2 MM THICK 600 RAD-INSIDE 300W	NOS	119	59		
b)	507-21125-A	LAD VER 90DEG BEND 2 MM THICK 600 RAD-INSIDE 600W	NOS	65	33		
3.3		LADDER TYPE VERTICAL 90 DEG. BEND-600mm RADIUS (OUTSIDE)					
a)	507-21129-A	LAD VER 90DEG BEND 2 MM THICK 600 RAD-OUTSIDE 300W	NOS	125	62		
b)	507-21131-A	LAD VER 90DEG BEND 2 MM THICK 600 RAD-OUTSIDE 600W	NOS	52	26		
3.4		LADDER TYPE TEES-600mm RADIUS					
a)	507-21135-A	LAD TEES 600MM RADIUS 2 MM THICK 300W	NOS	3	3		
b)	507-21136-A	LAD TEES 600MM RADIUS 2 MM THICK 450W	NOS	5	3		
c)	507-21137-A	LAD TEES 600MM RADIUS 2 MM THICK 600W	NOS	586	288		

	<p style="text-align: center;">TECHNICAL SPECIFICATION FOR CABLE TRAY & ACCESSORIES (TG PACAKGE)</p>	SPECIFICATION NO. PE-TS-400/402-507-E021	
		VOLUME IIB	
		SECTION - C	
		REVISION 0	DATE:- 15.05.2014
		SHEET	

NOTES:

- 1 The quantities will be released for manufacture in more than one lot. Lot-I quantities, which are indicated above, shall be released for manufacture along with LOI.
- 2 Manufacturing of Lot-I quantities shall be done after the approval of technical and quality documentation, and supply of same shall be completed within four months of date of approval of documents.
- 3 Subsequent lots shall be cleared for manufacture based on progress of engineering and site requirements. A lead-time of three months shall be given for completion of supply of each lot from the date of clearance of the quantities.
- 4 The total quantity variation shall be limited from -30 % to +30 % of the total contract value derived on the basis of the Order Quantities.
- 5 Raw materials: - Steel shall be procured from SAIL/TISCO/RINL/BHUSAN/JINDAL STEEL/JINDALISPAT/ESSAR/LLOYD/ IISCO/ authorised re-rollers of SAIL.
- 6 The number of coupler plates, washers, bolts & nuts shall be as per Data Sheet- A attached with the specification.

	TECHNICAL SPECIFICATION FOR CABLE TRAYS & ACCESSORIES	SPECIFICATION NO. PE-TS-400/402-507-E021	
		VOLUME II B	
		SECTION - C	
		REVISION 0	DATE: 15.05.2014
		SHEET 1 OF 1	

ANNEXURE – II

**LIST OF DRAWINGS / DOCUMENTS
(REQUIRED TO BE FURNISHED BY SUCCESSFUL BIDDER AFTER AWARD OF CONTRACT)**

Sl. No.	Drawings/Document Description	Drawings / Document Number	Submission Schedule
1.	Technical Data Sheet for Cable Trays & Accessories	PE-V0-400/402-507-E011	Within one week of award of contract
2.	GA drawings of Cable Trays & Accessories	PE-V0-400/402-507-E012	Within one week of award of contract
3.	Quality Plan for Cable Trays & Accessories	PE-V0-400/402-507-E902	Within one week of award of contract

Note:-

It may please be noted that successful bidder is not to make any fresh submittals at contract stage w.r.t. above mentioned drawings/documents. Data Sheet-A, Standard Quality Plan & Typical details of Cable trays & Accessories as enclosed in the technical specification are to be appended with cover sheet bearing drawing/document number & description as stated above. The signed & stamped for the same shall be submitted by successful bidder to BHEL within one week of award of contract without making any changes in the contents of the drawing/document.

	TECHNICAL SPECIFICATION FOR CABLE TRAYS & ACCESSORIES	SPECIFICATION NO. PE-TS-400/402-507-E021	
		VOLUME II B	
		SECTION - C	
		REVISION 0	DATE: 15.05.2014
		SHEET 1 OF 1	

ANNEXURE - III

(VENDOR DRAWING/DOCUMENT SCHEDULE)

S. NO.	DESCRIPTION	THROUGH DMS	HARD PRINTS	CD-ROMs
1	Docs. /drgs. for approval (First submission)	YES	-	-
2	Docs. / drgs. for approval (Second & subsequent submission till approval)	YES	-	-
3	Final approved docs. / drgs. for Distribution	YES	As per project specific requirement	As per project specific requirement



**STANDARD TECHNICAL SPECIFICATION
FOR CABLE TRAYS & ACCESSORIES**

SPECIFICATION NO. PE-TS- 999-507-E021

VOLUME II B

SECTION D

REVISION 1

DATE: 26/08/2011

SHEET 1 OF 3

SECTION-D

STANDARD TECHNICAL SPECIFICATION



**STANDARD TECHNICAL SPECIFICATION
FOR CABLE TRAYS & ACCESSORIES**

SPECIFICATION NO. PE-TS- 999-507-E021

VOLUME II B

SECTION D

REVISION 1

DATE: 26/08/2011

SHEET 2 OF 3

1.0 SCOPE OF ENQUIRY

1.1 This specification covers the design, manufacture, assembly, testing and inspection at vendor's/sub vendor's works, packing and despatch to site of **CABLE TRAYS & ACCESSORIES** as described in various sections of this specification.

2.0 CODES & STANDARDS

2.1 The material, constructional features and various processes involved in manufacture shall comply with latest revision of relevant Indian Standards.

2.2 The design, material, construction, manufacture, inspection, testing and performance of Cable Trays & Accessories shall conform to the latest revision of relevant standards and codes of practices mentioned in Data Sheet - A.

2.3 In case of conflict between the applicable reference standard and this specification, this specification shall govern.

3.0 DESIGN REQUIREMENTS AND CONSTRUCTIONAL FEATURES

3.1 All items listed in the BOQ –Cum-Price Schedule for Cable Trays & Accessories (Annexure - I of the specification) shall be manufactured as per Datasheet-A and project drawings enclosed with this specification. Minor fabrication detail changes which do not affect the material / dimensional aspect of the equipment, shall be to BHEL / owner's approval without any commercial implications.

3.2 Cable Trays & Accessories, Tray Covers and Fittings:

3.2.1 Cable trays & accessories shall be of two types, namely ladder type and perforated type as specified in Data Sheet A and drawings enclosed with this specification.

3.2.2 Coupler plates shall be provided for connecting tray ends to other straight trays, horizontal elbows, vertical elbows, tees, cross, reducers etc.

3.2.3 Necessary fasteners shall be provided along with each length of cable tray as specified in drawings enclosed. The number of coupler plates, washers, nuts & bolts to be supplied shall be as per Data Sheet – A.

3.2.4 The width of the tray covers (where provided) shall be suitable for the width of trays. Suitable bolting arrangement shall be supplied for attaching the cover to the cable trays, elbows, reducers, tees etc. as per the drawing enclosed.

3.2.5 All welded joints shall be smooth enough to provide a good appearance and shall not cause any injury to working personnel or any damage to the cable laid directly on it. All welding work shall be done by skilled personnel.

4.0 QUALITY / INSPECTION:

4.1 BHEL's Standard QP (QP NO. PED-507-00-Q-005/04) is enclosed for reference. However, at contract stage, the successful bidder shall submit the QP for BHEL/ ultimate customer's approval. In case bidder has reference QP agreed with ultimate customer, same can be submitted for specific project after award of contract for BHEL/ ultimate customer's approval. There shall be no commercial implication to BHEL on account of QP approval.

4.2 All materials shall be procured, manufactured, inspected and tested by vendor/ sub-vendor as per approved quality plan.



**STANDARD TECHNICAL SPECIFICATION
FOR CABLE TRAYS & ACCESSORIES**

SPECIFICATION NO. PE-TS- 999-507-E021

VOLUME II B

SECTION D

REVISION 1

DATE: 26/08/2011

SHEET 3 OF 3

4.3 The supplier shall perform all tests necessary to ensure that the material and workmanship conform to the relevant standards and comply with the requirements of the specification. Charges for all these tests for all the equipments & components shall be deemed to be included in the bid price.

4.4 Load Test:-

A 2.5 meter straight section of each type of cable tray of width 600mm shall be simply supported at the two ends. A uniformly distributed load of 100 kg per meter shall be applied along the length of tray. The maximum deflection at mid span shall not exceed 7 mm.

5.0 PACKING

The material shall be packed to ensure protection against damage during transit, storage for prolonged periods and handling.

6.0 DELIVERY

The delivery shall be as per NIT (Notice Inviting Tender).

7.0 DOCUMENTATION

7.1 Documents to be submitted by the bidder along with the bid.

- a) A copy of sheet "Contents" with bidder's signature & company stamp
- b) A copy of sheet "Instructions to bidders for preparing Technical offer" with bidder's signature & company stamp.
- c) Unpriced copy of "Annexure-I (BOQ – Cum- Price Schedule for Cable Trays & Accessories)" with bidder's signature & company stamp.

No other documentation is required to be submitted as technical offer. Any information contained in other parts of the offer (e.g. covering letter, annexures, etc.) which is deviating from specification requirements in any way shall not be considered by BHEL as part of offer.

7.2 Documents to be submitted by successful bidder after award of contract shall be as per Annexure-II.

7.3 Vendor drawing / document schedule for the project shall be as per Annexure – III.



**TECHNICAL SPECIFICATION FOR
CABLE TRAYS & ACCESSORIES**

SPECIFICATION NO.
PE-TS-400/402-507-E021

VOLUME II B

SECTION D

REVISION 0

DATE: 15.05.2014

SHEET 1 of 2

DATASHEET-A

1.0 APPLICABLE STANDARDS

- a) IS: 1079 For hot rolled carbon steel sheet and strip.
- b) IS: 1730 For dimensions for steel sheet and strip.
- c) IS: 1363 Hexagon head bolts, screws and nuts.
- d) IS: 2629 For hot dip galvanising of steel & surface pre treatment.
- e) IS: 2633 For testing of zinc coating.
- f) IS: 6745 For determining of mass of zinc coating.
- g) IS: 1367 Galvanised Coating on threaded Fasteners.
(Part-XIII)
- h) IS: 1852 For Rolling and Cutting Tolerances of hot rolled steel products.
- i) IS: 9595 For Thickness of Welding.

2.0 CABLE TRAYS & ACCESSORIES

- 2.1 Material : Hot Rolled Mild Steel
- 2.2 Type : Ladder Type
Perforated Type
- 2.3 Standard Length of
Straight Length of
Cable Trays : 2.5 meters
- 2.4 Standard Width (mm) : 600 450 300 150
- 2.5 Construction : Conforming to enclosed drawing [PE-DG-400-507-E005]
- 2.6 Bending Radius
of Accessories(in mm) : 600 mm
- 2.7 Tolerance in length/width
/ height : + /- 2 mm
- 2.8 Marking : Following shall be engraved/ punched on each standard length of cable tray
at the centre of both sides of runner:
'PEM' (length of letter 90mm & height 30mm).

3.0 FITTINGS

- End connections : Through Coupler plates
(Side Coupler Plates shall be provided as part of cable tray & accessories
supply with bolts, nuts, washers etc)

4.0 TRAY COVERS

- a) Type : Non-Perforated type.
- b) Material : Hot Rolled Mild Steel.



**TECHNICAL SPECIFICATION FOR
CABLE TRAYS & ACCESSORIES**

SPECIFICATION NO.
PE-TS-400/402-507-E021

VOLUME II B

SECTION D

REVISION 0

DATE: 15.05.2014

SHEET 2 of 2

c) Width : Suitable for width of cable trays.

d) Tolerance in length/
width / height : Same as cable trays.

5.0 SHEET THICKNESS

a) For cable trays &
Accessories : 2.0 mm

b) For cable tray cover : 1.6 mm

c) For Coupler plate : 2.0 mm

d) Tolerance in Thickness : (+/-0.2 mm)

6.0 SURFACE TREATMENT

a) Pre-treatment : IS 2629 before galvanisation

b) Type : Hot dip galvanisation

c) Applicable Standard : IS 2629

d) Minimum thickness : 75 microns (minimum)

e) Min. weight of
Zinc deposit : 610 grams per square meter

f) Tests for galvanizing : (i) Weight of Zinc Coating as per IS 6745.
(ii) Thickness of Zinc Coating as per IS 4759.
(iii) Uniformity of Zinc Coating as per IS 2633.
(iv) Adhesion Test as per IS 2629.

7.0 NUMBER OF COUPLER PLATES, BOLTS, WASHERS & NUTS REQUIRED FOR EACH CABLE TRAY SECTION (2.5 MTRS)

Sl. No.	NAME OF ITEM	COUPLER PLATE (nos.)	NUTS (nos.)	WASHERS (nos.)	BOLTS (nos.)
1	Cable tray of standard length 2.5 meters	4	16	32	16

NOTE: - Based on above table, no. of coupler plates, bolts, washers & nuts shall be calculated for the offered lot. Over & above the calculated quantity, additional 5% coupler plates & 10% bolts, washers & nuts shall be supplied by the bidder.

ANNEXURE – 1

INSTRUCTIONS FOR FILLING QUALITY PLAN

The Quality Plan shall include all the Quality Control Measures and Checks adopted by the Vendor to ensure that the material/component/assembly/services supplied by him meet/will meet the requirements as per specifications and good practices. They shall include all stages of operation such as materials, processes, manufacture, assembly, packing and despatch. The following guide lines may be noted:

- Column 1- Serial Number
- Column 2- Component/Operation- The component and/or operation being checked shall be given here.
- Column 3- Characteristics check- The characteristics being checked shall be given here, e.g., chemical composition, mechanical properties, leak tightness, surface defects etc..
- Column 4- Category -'CR' stands for critical characteristic - affecting safety of equipment and personnel
'MA' stands for major Characteristic - affecting safety of equipment and personnel
'MI' stands for minor characteristic - affecting appearance etc.
- Column 5- Type/Method of check e.g. chemical analysis tensile testing, hydraulic test, visual examination radiography etc.
- Column 6- Extent of check, such as, 100, 10, 1 percent etc.
- Column 7- Reference Documents - Documents, such as technical specification, drawings, standard specifications (IS, BS ETC.) procedure, etc. according to which check is done.
- Column 8- Acceptance Norms - Standards etc. according to which acceptability or otherwise of the characteristics being checked is decided.
- Column 9- Format of Record - Formats, log sheets, reports, etc. in which the observations are recorded. Standard log sheets, reports, formats etc. of the Vendors shall be numbered and such reference numbers shall be included here.
- Column 10- Agency - The agency which performs the test/instruction shall be written in sub-column 'W'
The agency which verifies test certificates/inspection records and carries out audit check of the components/operation shall be written in sub-column 'V'
- The agencies are codified as 1,2 & 3
- '1' stands for (BHEL)
- '1' * means the operation shall be cleared by BHEL before the start of the next operation.
- '2' Stands for Vendor
- '3' stands for sub-Vendor of the Vendor and so on.
- Example :
- Entry '3' in column 'P' means test./inspection to be performed by sub-Vendor's QC
- Entry '2' in column 'W' means test./inspection to be witnessed by Vendor's QC
- Entry '1' in column 'V' means verification shall be done by BHEL and next stage to be started only after the hold point is cleared by BHEL
- Column 11- Remarks - Any special remarks shall be given here.

NOTES :

- In absence of correlation with the test certificate(s) (e.g. material identification) samples shall be drawn by BHEL and all tests as per relevant specifications shall be carried out in their presence or in recognized Government Laboratory.
- When materials and components are initially identified and stamped by BHEL QS engineer, the identification marks shall be preserved till despatch. Wherever this is not possible, the identification mark shall be transferred to the components in the presence of BHEL QS Engineer unless otherwise agreed.
- For castings and forgings integral test specimens shall be provided, When this is not possible for casting, they shall be poured in the presence of BHEL QS Engineer unless otherwise, if witnessing of test by BHEL is called for.
- When welders qualified by reputed inspection agencies or statutory bodies are not available, qualification tests shall be conducted in the presence of BHEL QS Engineer.
- This Quality Plan is liable to be modified as per the requirements of approved drawings and changes in technical specifications/drawings. If there are contradictions in respect of column 7 & 8 between this Quality Plan and the approved drawings specifications, the latter shall prevail.
- Wherever inspection by BHELs Purchaser/Third Party/Statutory authorities are mandatory, this shall be complied with.
- Inspection reports, log sheets, test reports/certificate. etc. shall be furnished to BHEL at the appropriate stages or at the time of final inspection, as required.
- This Quality Plan is also applicable to spares, if any, under scope of supply of Vendor.
- The quality plan shall be submitted in minimum 4 copies with a soft copy of the same or in line with contract requirements.

ANNEXURE -2 of Quality Plan

(LIST OF BHEL- PEM APPROVED GALVANIZERS)

SL. NO.	ITEM	VENDOR NAME	ADDRESS
1	GALVANISING	JENCO INDUSTRIAL CORPORATION	CHINCHOLI BUNDER KHKAR ROAD NEAR LINK ROAD DEVRUWADI MALAD (W) MUMBAI 400064
2	GALVANISING	NATIONAL GALVANISING COMPANY	66, BARRACKPORE KAMARHATT TRUNCK ROAD CALCUTTA-700058
3	GALVANISING	SIGMA GALVANISING PVT.LTD	PLOT NO.C-169, TTC, MIDC IND AREA NAVIN MUMBAI-400705
4	GALVANISING	B.P. PROJECTS PVT LTD	167A, VIVEKANANDA ROAD KOLKATA-700006
5	GALVANISING	STANDARD GALVANISERS	Makardah Road, Kabar Para, Bankra, Howarah - 711403
6	GALVANISING	STEEL PRODUCTS	National Highway No. 6, Chamrail, Kona, Howrah-711114
7	GALVANISING	UNITECH FABRICATORS & ENGINEERS PVT. LTD.	VILLAGE- AJAB NAGAR, P.O. -MOLLA SIMLLA, P.S. - SINGUR, DIST - HOOGLY, PIN-712223
8	GALVANISING	M/s Shivam Engineers & Fabricators	A0-282-284, Industrial area, South side of G.T. road, Ghaziabad, U.P.
9	GALVANISING	M/s B.G. Shirke Construction Technology Pvt. Ltd.	Office & factory : 72-76, Mundhawa, Pune - 401 036
10	GALVANISING	M/s Galbro Ispat Galvanizers Pvt. Ltd.	Gut 11 and 12, Opp. Kudus Steel Rolling mill, Wada, Thane , Mumbai

Note:- The above list doesn't include the list of BHEL - PEM approved galvanizing plants owned by BHEL - PEM registered vendor of cabling packages.

		QUALITY PLAN		CUSTOMER : NEYVELI LIGNITE CORPORATION L			PROJECT TITLE :2x500 MW NEYVELI NEW THERMAL POWER		SPECIFICATION NO. :PE-TS-400/402-507-E021			
				PROJECT			STANDARD QP NO. : PE-QP-999-507-E005, REV. 0		SPECIFICATION TITLE:			
		SHEET 1 OF 2		SYSTEM CABLING			ITEM : CABLE TRAYS & ACCESSORIES			DOC. NO. :		
SL. NO.	COMPONENT/OPERATION	CHARACTERISTIC CHECK	CAT.	TYPE/METHOD OF CHECK	EXTENT OF CHECK	REFERENCE DOCUMENT	ACCEPTANCE NORM	FORMAT OF RECORD	AGENCY			REMARKS
									P	W	V	
1	2	3	4	5	6	7	8	9	10			11
1.0	RAW MATERIAL											
1.1	ROLLED SHEET	1.CHEM.& PHY. PROPERTIES	MA	VERIFICATION OF TC'S	100%	IS1079	IS1079	MILL TC	3/2	-	1/2	Steel shall be procured from SAIL/TISCO/RINL/BHUSAN/JINDAL STEEL/JINDAL ISPAT/ESSAR/ LOYD/ IISCO / authorised SAIL Re Rollers.
		2.DIMENSIONS	MA	MEASUREMENT	100%	IS-1730/ APPD. DATA SHEET	IS-1730/ APPD. DATA SHEET	QC RECORD	3/2	-	-	
		3.SURFACE FINISH	MA	VISUAL	100%	IS-1079	IS-1079	QC RECORD	3/2	-	-	
1.2	ZINC	CHEM.COMP.	MA	CHEM TEST	EACH HEAT	IS-209	IS-209	QC RECORD	3/2	-	1/2	
2.0	IN-PROCESS											
2.1	FABRICATION	1.DIMENSIONS	MA	MEASUREMENT	100%	APPD.DRG.	APPD.DRG.	QC RECORD	2	-	1	Welding is to be done by qualified welders in accordance with ASME SEC. IX article III. WPS , PQR & WPQ to be reviewed during inspection.
		2.WELDING QUALITY	MA	VISUAL	100%	GOOD WELDING PRACTICE	FREE FROM DEFECTS & SLAG	QC RECORD	2	-	1	
		3.SURFACE FINISH	MA	VISUAL	100%	APPD.DRG.	APPD.DRG.	QC RECORD	2	-	1	
2.2	SURFACE PREPARATION	1.CLEANING PICKLING & RINSING & FLUXING	MA	VISUAL	PERIODIC IN EACH SHIFT	IS:2629	IS:2629	QC RECORD	2	-	-	
		2. SURFACE QUALITY	MA	VISUAL	100%	IS:2629	IS:2629	QC RECORD	2	-	-	
BHEL			PARTICULARS			BIDDER/VENDOR						
			NAME									
			SIGNATURE									
			DATE						BIDDER'S/VENDORS COMPANY SEAL			

LEGEND : 1 - BHEL/ CUSTOMER 2 - VENDOR 3 - SUB- VENDOR P - PERFORM W - WITNESS V - VERIFICATION



QUALITY PLAN		CUSTOMER : NEYVELI LIGNITE CORPORATION L				PROJECT TITLE :2x500 MW NEYVELI NEW THERMAL POWER PROJECT			SPECIFICATION NO. :PE-TS-400/402-507-E021			
		BIDDER/ VENDOR :				STANDARD QP NO. : PE-QP-999-507-E005, REV. 0			SPECIFICATION TITLE:			
SHEET 2 OF 2		SYSTEM CABLING				ITEM : CABLE TRAYS & ACCESSORIES			DOC. NO. :			
SL. NO.	COMPONENT/OPERATION	CHARACTERISTIC CHECK	CAT.	TYPE/METHOD OF CHECK	EXTENT OF CHECK	REFERENCE DOCUMENT	ACCEPTANCE NORM	FORMAT OF RECORD	AGENCY			REMARKS
									P	W	V	
1	2	3	4	5	6	7	8	9	10			11
2.3	GALVANISING	1.TEMPERATURE OF ZINC BATH 2.DROSS 3.RATE OF IMMERSION 4.SURFACE QUALITY	MA MA MA MA	TEMPERATURE INDICATOR VISUAL VISUAL VISUAL	CONTINUOUS PERIODIC 100% 100%	IS-2629 IS 2629 IS 2629/ MFR'S PRACTICE IS 2629	IS-2629 IS 2629 IS2629/ MFR'S PRACTICE FREE FROM BURRS ROUGHNESS, SLAG FLUX. STAIN. ETC.	QC RECORD QC RECORD QC RECORD QC RECORD	2/3 2/3 2/3 2/3	- - - -	- - 2 -	If vendor doesn't have his own galvanizing plant duly approved by BHEL PEM; then galvanizing shall be carried out at BHEL-PEM approved other galvanizing plants as per Annexure-2. Fasteners shall be of reputed make. Overall thickness of finished product shall not be less than the thickness of cable tray & accessories defined in technical datasheet. Following shall be engraved/ punched on each standard length of cable tray at the center of both sides of runner:'PEM' (length of letter 90mm & height 30mm). 600MM wide cable tray to be testsed. Maximum deflection shall not exceed 7MM on mid span on uniform loading of 100KG/M.
3.0	FINISHED ITEMS											
3.1	(CABLE TRAY, ACCESSORIES & HARDWARES)	1.DIMENSIONS 2.SURFACE FINISH 3.RIGIDITY (FOR TRAYS) 4.MASS OF ZINC COATING 5.UNIFORMITY OF ZINC COATING 6.THICKNESS OF ZINC COATING 7.ADHESION	MA MA MA MA MA MA MA	MEASUREMENT VISUAL DEFLECTION TEST CHEM. TEST CHEM. TEST ELCOMETER MECH.TEST	IS-2500 (PART 1) LEVEL S-4 IS-2500 (PART 1) LEVEL S-4 2 No./ LOT/TYPE IS-4759 IS-4759 IS-4759 IS-4759	APPD. DRG APPD. DRG APPD. DRG IS-6745/ APPD. DATASHEET IS-2633 APPD. DATASHEET IS-2629	APPD. DRG FREE FROM BURRS, SLAG, ROUGHNESS, FLUX. STAIN. ETC. APPD. DRG APPD. DATASHEET IS-2633 APPD. DATASHEET IS-2629	INSP.REPORT INSP.REPORT INSP.REPORT INSP.REPORT INSP.REPORT INSP.REPORT INSP.REPORT	2 2 2 2 2 2 2	1 1 1 1 1 1 1	- - - - - - -	
BHEL			PARTICULARS			BIDDER/VENDOR						
			NAME									
			SIGNATURE									
			DATE						BIDDER'S/VENDORS COMPANY SEAL			

LEGEND : 1 - BHEL/ CUSTOMER 2 - VENDOR 3 - SUB- VENDOR P - PERFORM W - WITNESS V - VERIFICATION



LAHMEYER
INDIA

LAHMEYER INTERNATIONAL INDIA PVT. LTD.

APPROVED

THIS APPROVAL STATUS SHALL NOT RELIEVE THE CONTRACTOR FROM HIS

DATE: 23.04.2014	NAME: DEEPAK	SIGNATURE: 	DEPARTMENT: ELECTRICAL
----------------------------	------------------------	-----------------------	----------------------------------

TYPICAL DETAILS OF CABLE TRAYS AND ACCESSORIES

CUSTOMER		नेवेली लग्निनाइट कॉर्पोरेशन लिमिटेड (एनएलसी लिमिटेड)			
		NEYVELI LIGNITE CORPORATION LIMITED (NLC LTD)			
CONSULTANT		लहमेयर इंटरनेशनल इंडिया प्राइवेट लिमिटेड			
		M/s LAHMEYER INTERNATIONAL (INDIA) PVT LTD			
PACKAGE: STEAM GENERATOR AND AUXILIARIES (NAT1)					
NEYVELI NEW THERMAL POWER PROJECT (NNTPP) 2X500 MW LIGNITE FIRED UNITS AT NEYVELI					
	BHARAT HEAVY ELECTRICALS LTD BOILER PLANT UNIT TIRUCHIRAPALLI-620014	DEPT	NAME	SIGN	DATE
		DRN	SuM	-ed-	18.01.2014
		DESN	SuM	-ed-	18.01.2014
		CHD	MS	-ed-	18.01.2014
		APPD	RG	-ed-	22.01.2014
		REV.	DATE	ALTD.	CHK.
		01	25.03.14		
<small>REVISED TO INCORPORATE NLC'S COMMENTS DATED 03.02.2014 ALONG WITH BHEL REPLIES DATED 25.05.2014</small>					
				DEPT.	SCALE
				DRN	
				DATE	DRAWING No.
					PE-DG-400-507-E005
				SHEET	NO.
				01 OF 11	REV 1

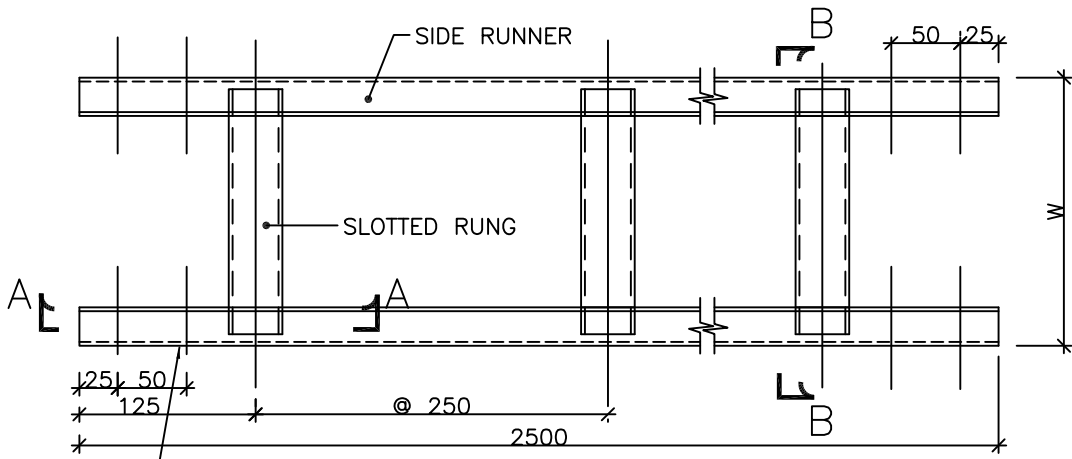

LADDER TYPE CABLE TRAY

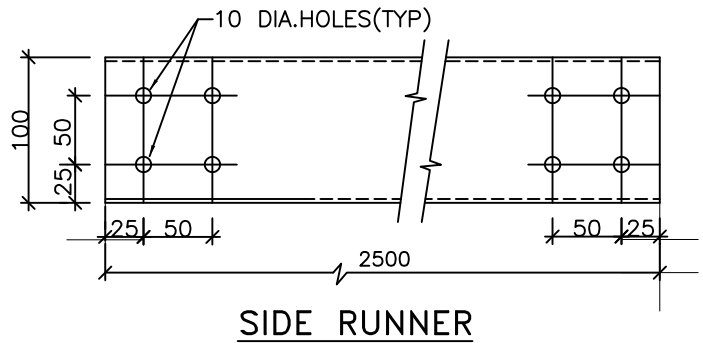
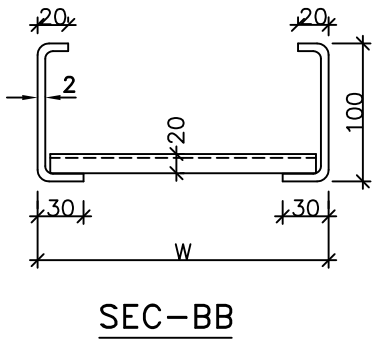
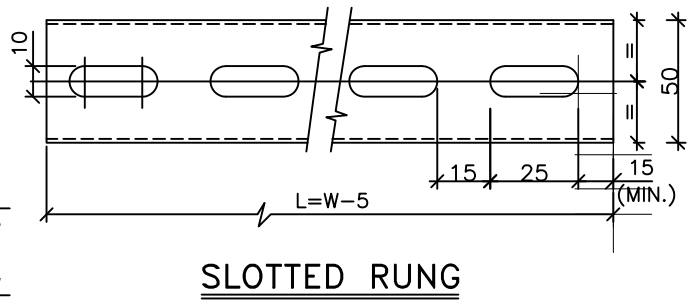
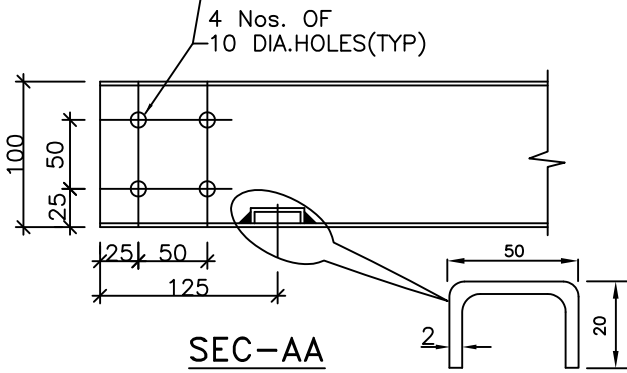

W	150	300	450	600
L	145	295	445	595

FOR GENERAL NOTES REFER SHEET 11 OF 11



TYPICAL DETAILS OF CABLE TRAYS AND ACCESSORIES

DWG. NO.
PE-DG-400-507-E005

SHT. 02 OF 11 REV. 1

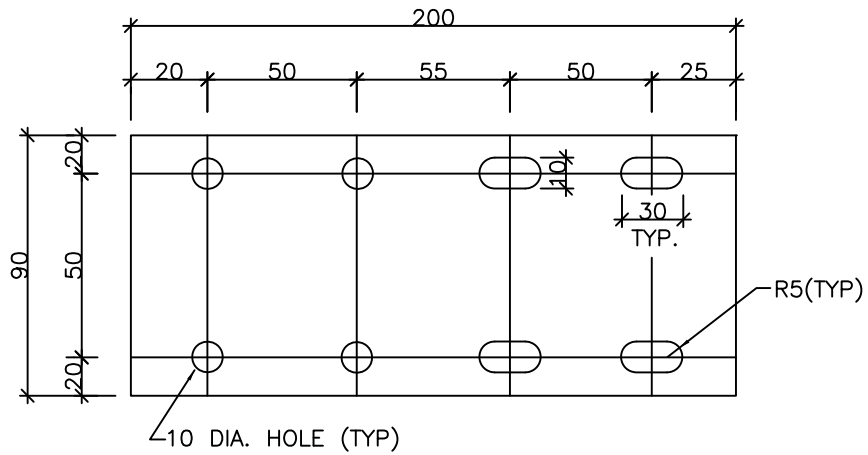

**SIDE COUPLER PLATE FOR
LADDER/PERFORATED TYPE TRAYS
(600/450/300/150W TRAYS)**

QTY. REQUIRED/TRAY SECTION : 4 NOS.

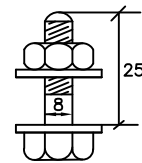
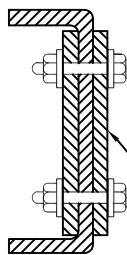

QTY. REQD/TRAY SECTION

- A) 16 NOS. M8 BOLTS
- B) 16 NOS. NUTS
- C) 32 NOS. WASHERS

(2 NOS. COUPLER PLATE
OF 2 MM THICKNESS TO
BE SUPPLIED PER JOINT)

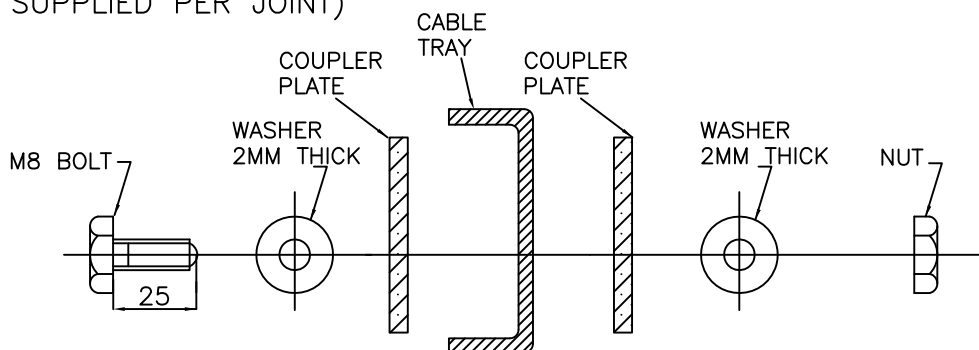

SEQUENCE OF M8 BOLT, WASHER, NUT, COUPLER PLATE & CABLE TRAY
FOR TYPICAL CABLE TRAY JOINT

FOR GENERAL NOTES REFER SHEET 11 OF 11



TYPICAL DETAILS OF CABLE TRAYS AND
ACCESSORIES

DWG. NO.
PE-DG-400-507-E005

SHT. 03 OF 11 REV. 1

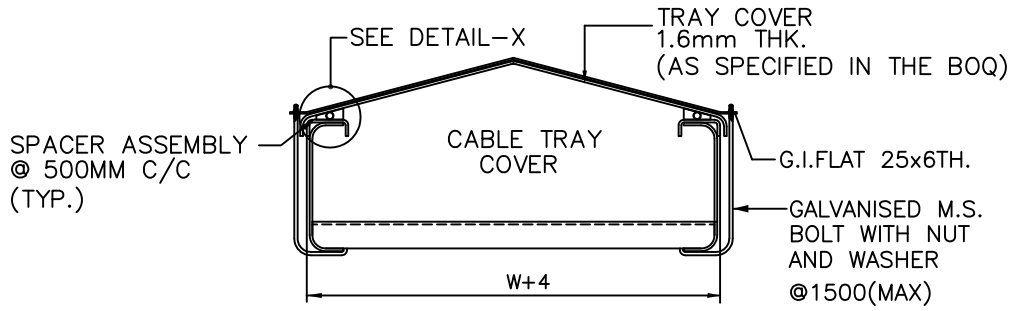

COVER FIXING (TYP.)

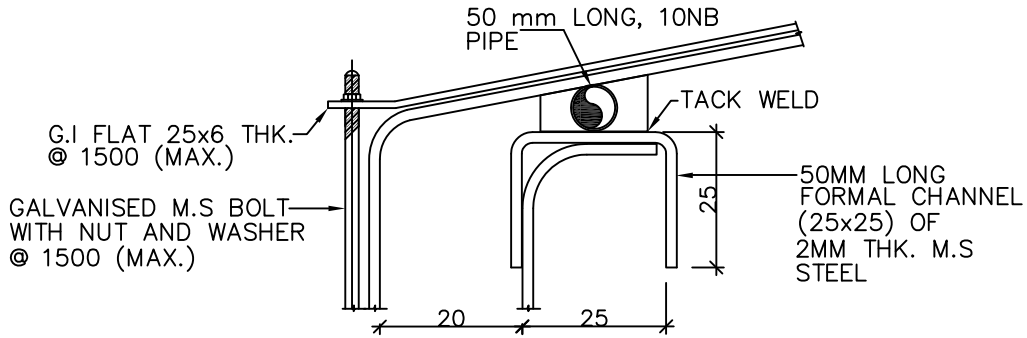

DETAIL-X

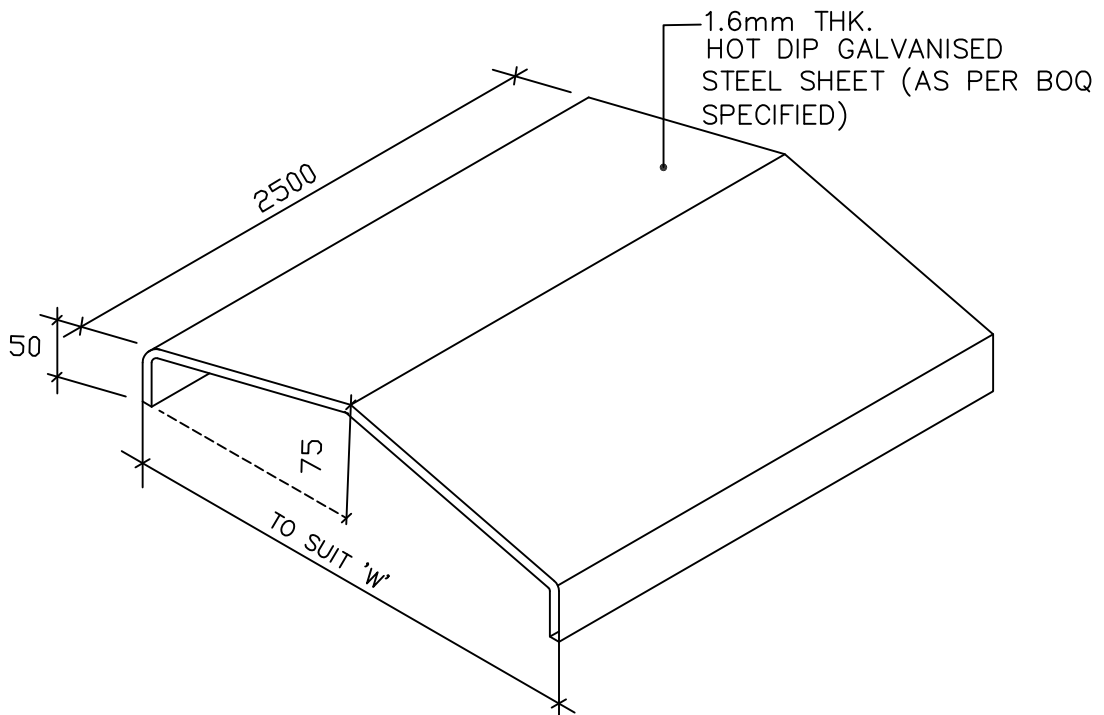

CABLE TRAY COVER

FOR GENERAL NOTES REFER SHEET 11 OF 11



TYPICAL DETAILS OF CABLE TRAYS AND ACCESSORIES

DWG. NO.
PE-DG-400-507-E005

SHT. 04 OF 11 REV. 1

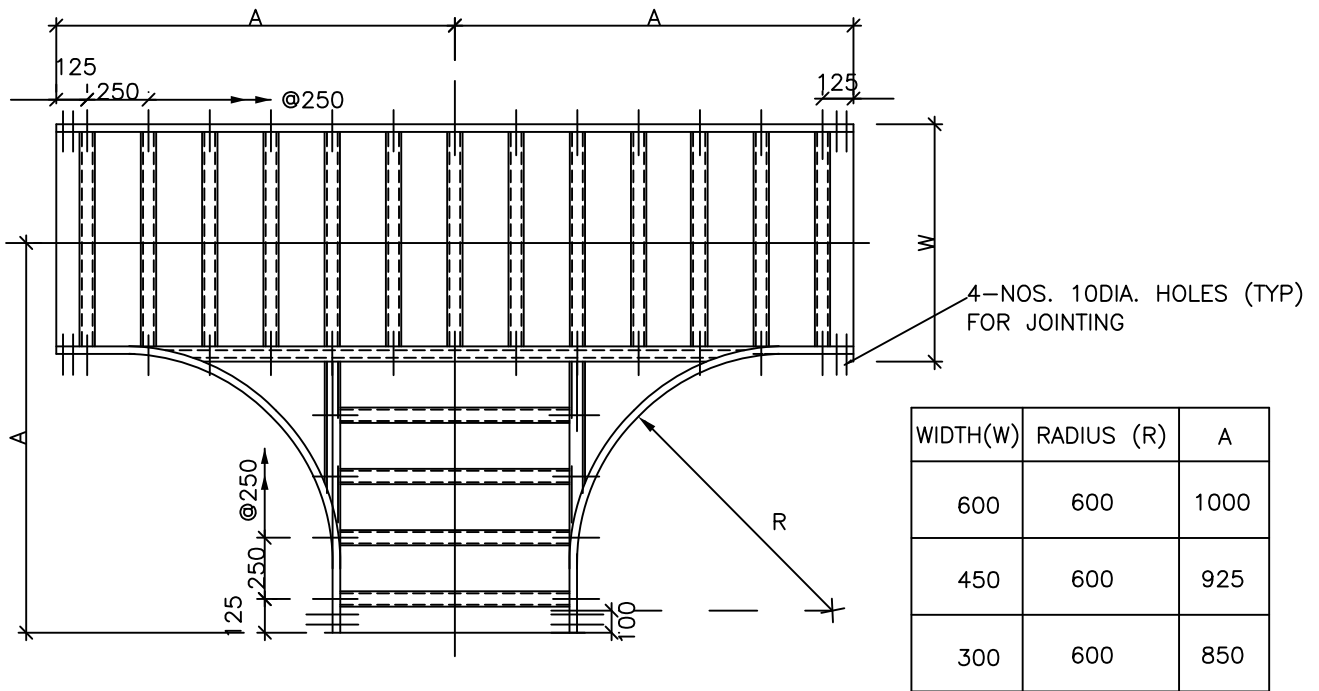

HORIZONTAL TEE-PLAN

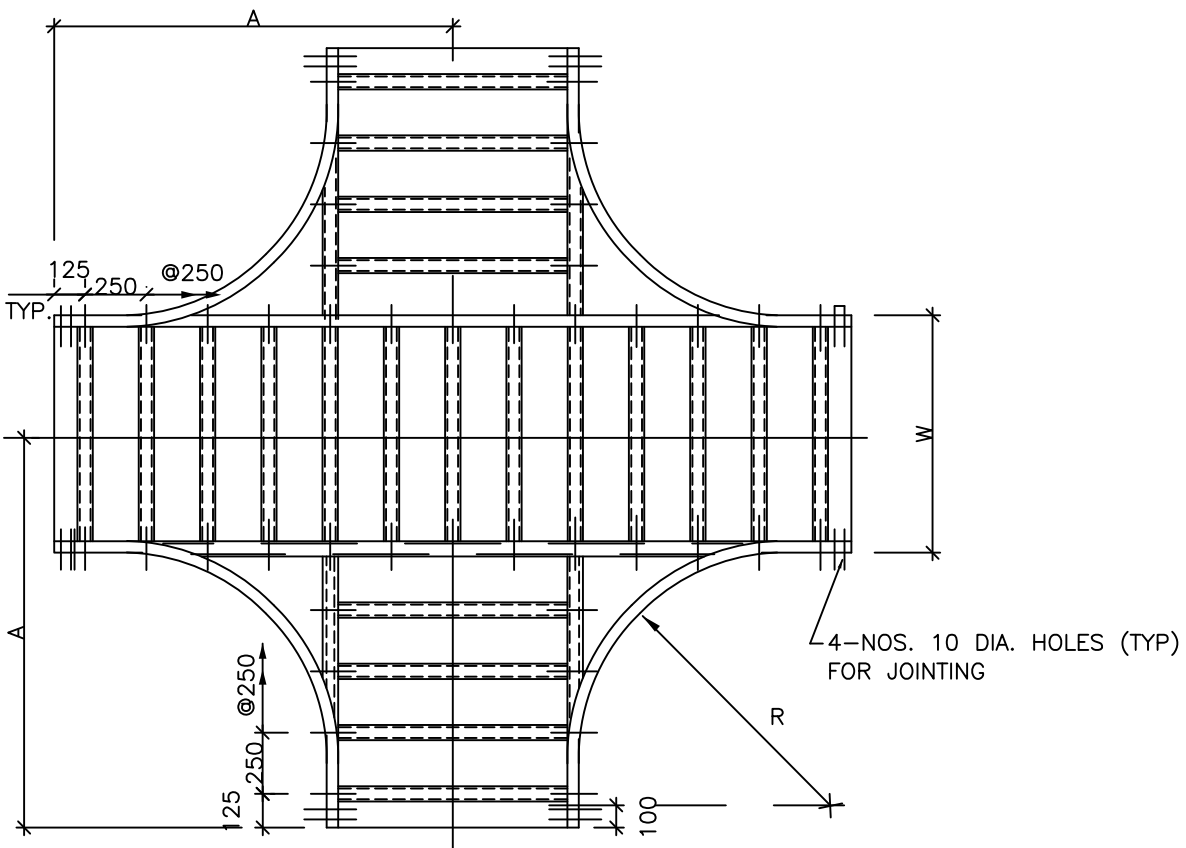

HORIZONTAL CROSS-PLAN

LADDER TYPE ACCESSORIES

FOR GENERAL NOTES REFER SHEET 11 OF 11



TYPICAL DETAILS OF CABLE TRAYS AND ACCESSORIES

DWG. NO.
PE-DG-400-507-E005

SHT. 05 OF 11 REV. 1

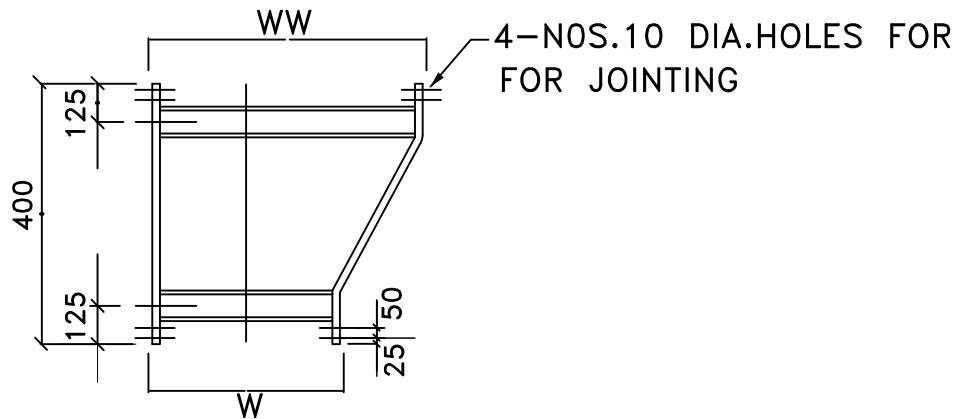

LEFT HAND REDUCER-PLAN

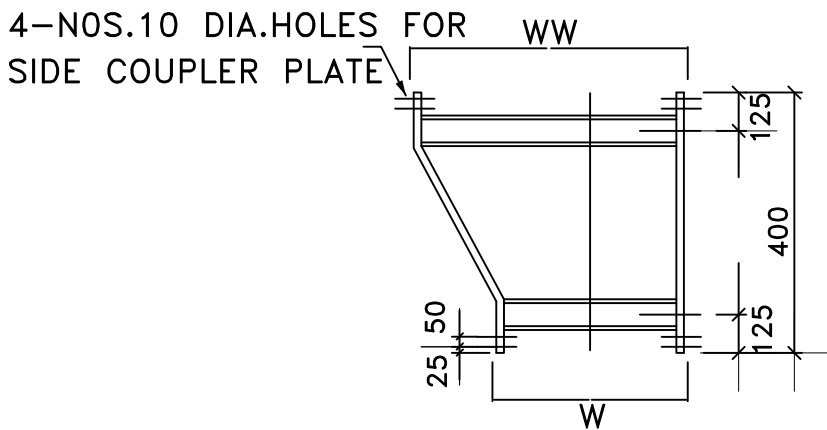

RIGHT HAND REDUCER-PLAN

WIDTH	WW	600	600	450
	W	450	300	300

LADDER TYPE ACCESSORIES

FOR GENERAL NOTES REFER SHEET 11 OF 11



TYPICAL DETAILS OF CABLE TRAYS AND ACCESSORIES

DWG. NO.
PE-DG-400-507-E005

SHT. 06 OF 11 REV. 1

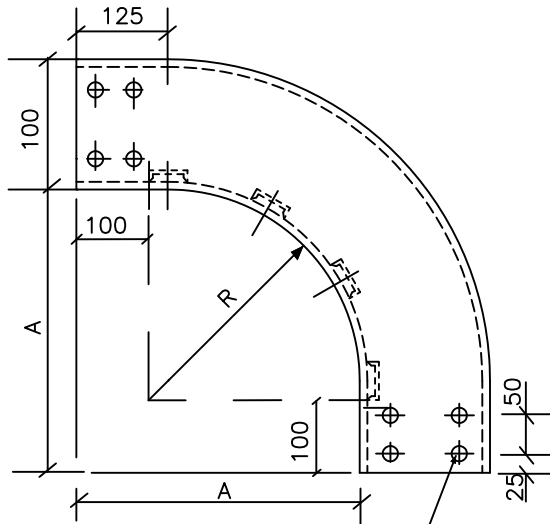

ELEVATION
90° VERTICAL BEND
(OUTSIDE)

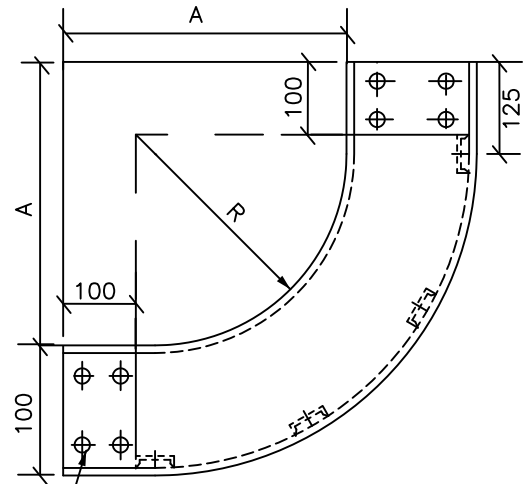

ELEVATION
90° VERTICAL BEND
(INSIDE)

4 NOS. 10 DIA. HOLES
FOR JOINTING

LADDER TYPE TRAYS

WIDTH(W)	RADIUS (R)	A
600	600	700
450	600	700
300	600	700

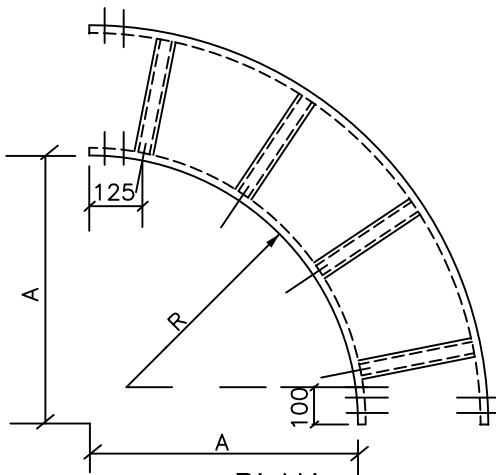

PLAN
90° HORIZONTAL BEND

LADDER TYPE ACCESSORIES

FOR GENERAL NOTES REFER SHEET 11 OF 11



TYPICAL DETAILS OF CABLE TRAYS AND
ACCESSORIES

DWG. NO.
PE-DG-400-507-E005

SHT. 07 OF 11 REV. 1

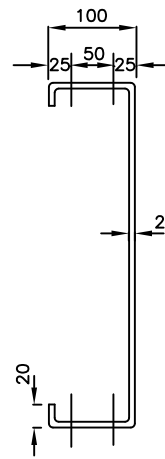
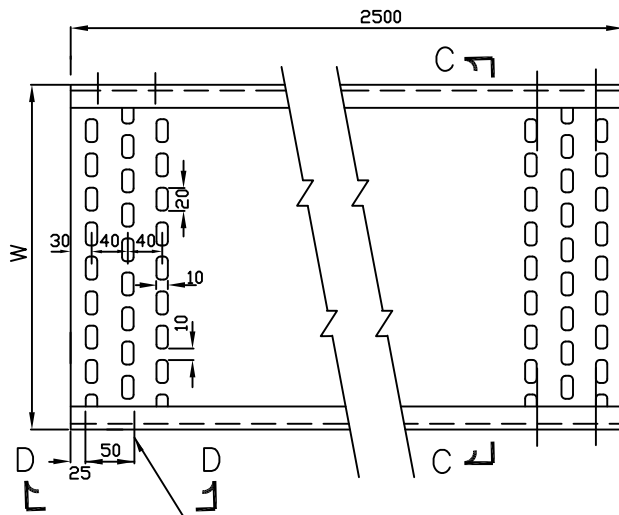

SECTION-CC
(600/450/300/150 TRAYS)

4 HOLES 10mm DIA.

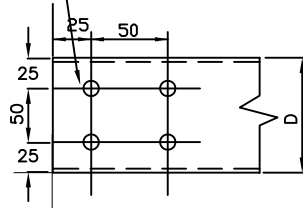

VIEW-DD
(600/450/300/
150W TRAYS)

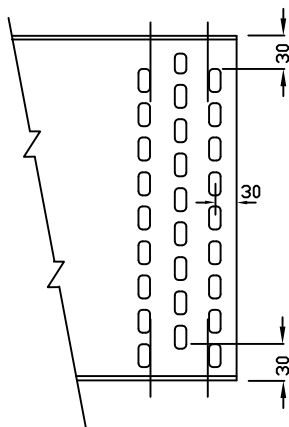

ARRANGEMENT OF
PERFORATIONS

TRAY WIDTH W (mm)	600	450	300	150
TRAY DEPTH D (mm)	100	100	100	100

PERFORATED TYPE TRAY

FOR GENERAL NOTES REFER SHEET 11 OF 11



TYPICAL DETAILS OF CABLE TRAYS AND
ACCESSORIES

DWG. NO.
PE-DG-400-507-E005

SHT. 08 OF 11 REV. 1

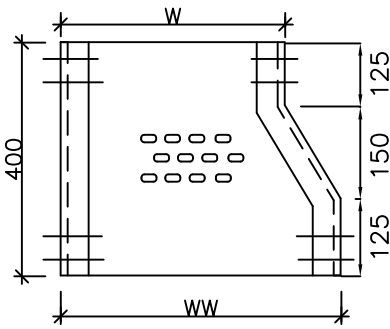

LEFT HAND REDUCER

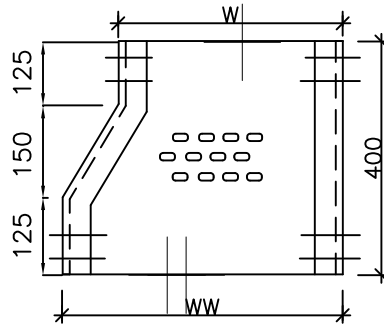

RIGHT HAND REDUCER

WW	W	DEPTH
600	450	100
600	300	100
450	300	100

PERFORATED TYPE

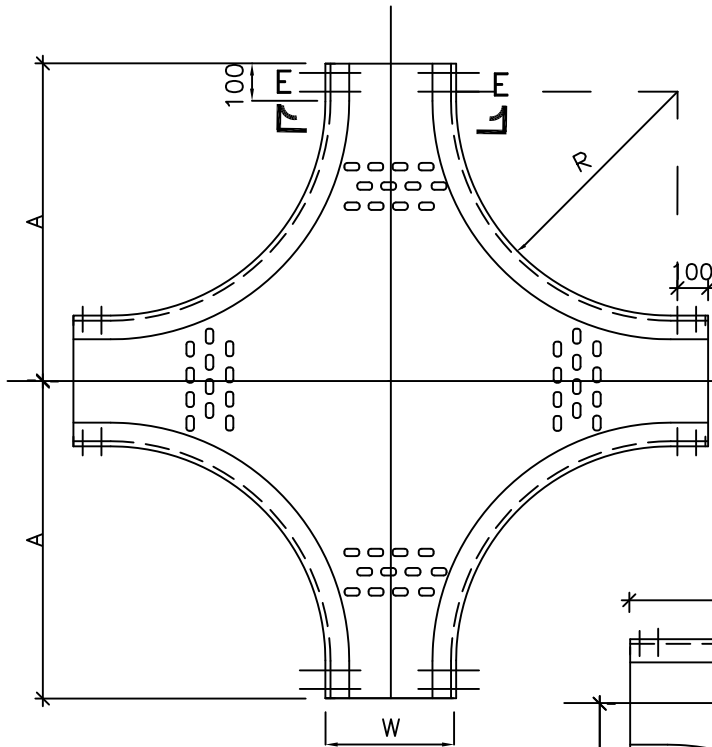

CROSS

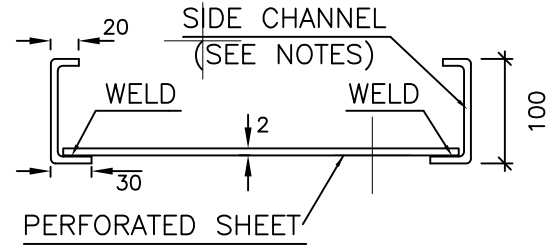

SECTION-EE

PERFORATED TYPE

WIDTH(W)	RADIUS (R)	A
600	600	1000
450	600	925
300	600	850

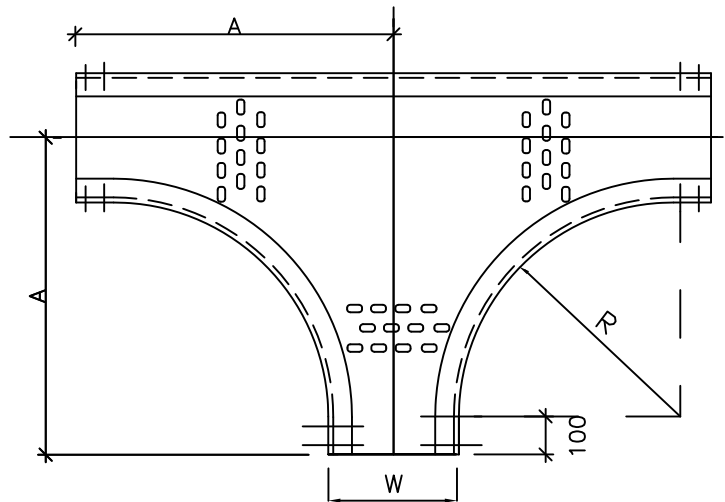

TEE

PERFORATED TYPE ACCESSORIES

FOR GENERAL NOTES REFER SHEET 11 OF 11



TYPICAL DETAILS OF CABLE TRAYS AND ACCESSORIES

DWG. NO.
PE-DG-400-507-E005

SHT. 09 OF 11 REV. 1

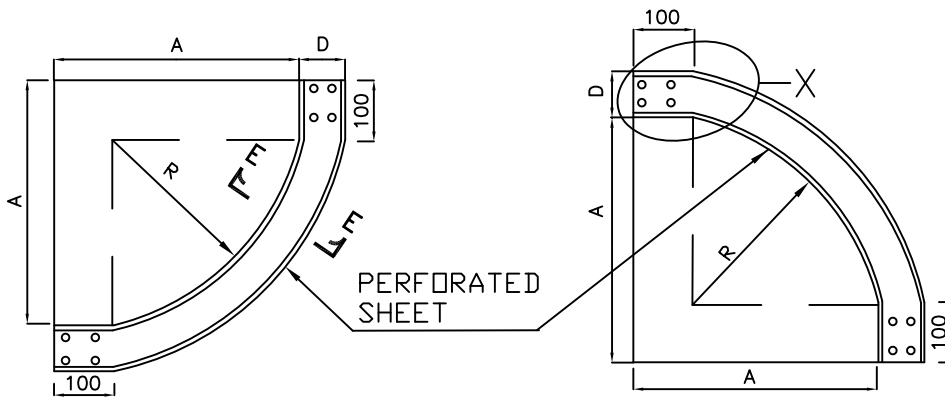

INSIDE TYPE

OUTSIDE TYPE

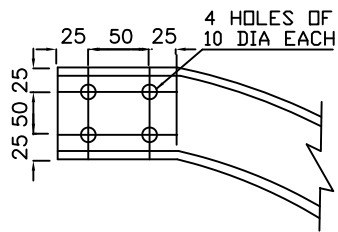

ENLARGED VIEW OF "X"

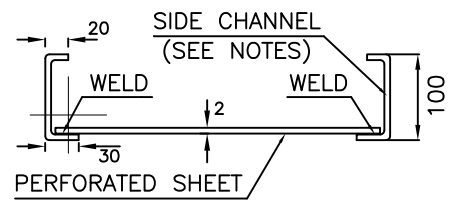

SECTION-EE

90° VERTICAL BEND - PERFORATED TYPE

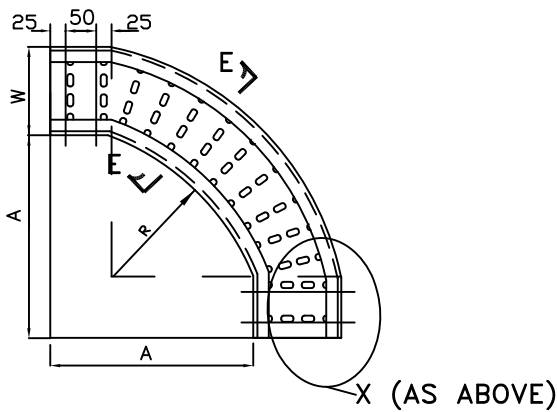

90° HORIZONTAL BEND - PERFORATED TYPE

WIDTH(W)	RADIUS (R)	A
600	600	700
450	600	700
300	600	700

PERFORATED TYPE ACCESSORIES

FOR GENERAL NOTES REFER SHEET 11 OF 11



TYPICAL DETAILS OF CABLE TRAYS AND ACCESSORIES

DWG. NO.
PE-DG-XXX-507-E005

SHT. 10 OF 11 REV. 1

NOTES:-

1. THE LADDER AND PERFORATED TYPE CABLE TRAYS AND ACCESSORIES (INCLUDING SIDE RUNNERS OF LADDER TYPE TRAYS & ACCESSORIES) SHALL BE MADE OF 2MM HOT ROLLED M.S. SHEET. ALL THE COUPLER PLATE SHALL BE 2 MM THICK.
2. THE CABLE TRAYS & ACCESSORIES SHALL BE HOT DIP GALVANISED AS PER IS 2629. THE MASS OF ZINC COATING SHALL BE 610 gm/m² AND THICKNESS SHALL BE 75 MICRONS (MINIMUM).
3. FOR LADDER TYPE CABLE TRAYS AND ACCESSORIES, ALL RUNGS SHALL BE SLOTTED.
4. PERFORATED TRAYS SHALL BE FABRICATED OUT OF A SINGLE M.S. SHEET.
5. STANDARD TRAY ACCESSORIES SHALL BE WITH THE RADIUS INDICATED IN THIS DRAWING.
6. SIDE CHANNELS OF PERFORATED TYPE CABLE TRAY ACCESSORIES SHALL BE WELDED WITH THE PERFORATED SHEET AT INTERVALS OF 100mm.
7. LENGTH OF WELDING SHALL NOT BE LESS THAN 25mm FOR CABLE TRAYS. THE THICKNESS OF WELDING SHALL BE AS PER IS 9595.
8. ALL TRAY CORNERS SHALL BE SMOOTH AND FREE OF SHARP EDGES.
9. THE CABLE TRAY COVER SHALL BE OF 1.6MM THICK MS SHEET AND SHALL BE HOT DIP GALVANISED.
10. THE DEPTH, WIDTH AND LENGTH OF TRAYS & TRAY COVERS SHALL BE WITHIN A TOLERANCE OF (+/-) 2 mm. THE THICKNESS TOLERANCE IS OF (+/-) 0.2 mm AS PER IS 1852.
11. THE THICKNESS OF THE FINISHED PRODUCT SHALL NOT BE LESS THAN 2MM.
12. TO FACILITATE ASSEMBLY, ALL ACCESSORIES AT ENDS SHALL HAVE 100mm STRAIGHT PORTION.
13. ALL NUTS, BOLTS, WASHERS ETC., SHALL BE HOT DIP GALVANISED AS PER IS:1367 PART XIII FOR SIZES 12 MM & ABOVE, AND ELECTROPLATED/ZINC PASSIVATED FOR SIZES UPTO 12 MM.
14. ALL CUTTING & FORMING OPERATIONS SHALL BE COMPLETED PRIOR TO GALVANIZING.
15. FINISHED TRAYS SHALL BE FREE FROM BURRS AND SHARP EDGES.
16. ALL DIMENSIONS ARE IN mm UNLESS NOTED OTHERWISE.
17. WIDTH OF CABLE TRAYS PROPOSED TO BE USED FOR THE PROJECT ARE AS UNDER:
A) LADDER TYPE: 600W, 450W, 300W, 150W.
B) PERFORATED TYPE: 600W, 450W, 300W, 150W.
18. THE DEPTH OF 600W, 450W, 300W, 150W TRAYS & ACCESSORIES SHALL BE 100MM.
19. 600MM WIDE TYPE CABLE TRAYS SHALL BE SUITABLE FOR A CABLE WEIGHT OF 100 Kg PER METRE (INCLUDING LIVE LOAD) OF RUNNING LENGTH OF TRAY.
20. EARTH CONTINUITY AND EARTH CONNECTION OF CABLE TRAYS SHALL BE CHECKED BEFORE LAYING THE CABLES.



TYPICAL DETAILS OF CABLE TRAYS AND ACCESSORIES

DWG. NO.
PE-DG-400-507-E005

SHT. 11 OF 11 REV. 1