



2x500 MW, NNTPP, Neyveli
CONTRACT SPECIFICATION
STEAM GENERATOR & AUX. PACKAGE - NTA1



3. The design of thermocouple assemblies shall be such that replacement on line is possible.
4. Gas-tight ceramic sheaths partially reinforced with stainless steel sheath shall be used as protective tube for Pt Rh - Pt thermocouples. For other type of thermocouple stainless steel tubes shall be used as protective sheaths. For measuring temperature of high pressure process fluid, tapered protection sheath made from solid bar stock shall be used.
5. The time-constant of thermocouples shall suit the process requirement and shall be subject to approval of Owner / Consultant.
6. The thermocouples shall be supplied with factory tested and calibrated assemblies. The assemblies shall be complete with thermo well, sensing element, connection lead, duplex terminal block, extension nipple, compression fittings / unions /flanges etc. to meet all functional requirements as per Owner's / Consultant's approved drawings. The thermocouples equipped with thermo well shall be spring loaded for positive contact with the well.
7. The duplex terminal block shall be constructed with high temperature ceramic base with brass screw type terminals.
8. Thermocouple shall be suitable for steam, water or any other liquid application. For air & flue gas service, suitable protection tubes shall be provided for the thermocouples.
9. All thermocouples (except metal thermocouples) shall be terminated to the nearest junction boxes. The cold junction compensation shall be implemented within the measuring module level, no local/ field cold junction compensation box is allowed.

9.5 Resistance Temperature Detector (RTD)

Table 9.4
Specifications for RTD

S.N	Features	Minimum Requirements
1	Type	3 / 4 wire , Pt-100 (100 ohm at 0 deg C) (as per DIN 43760)
2	No. of Element	Duplex
3	Housing/Head	IP-65/Diecast Aluminium. Plug in connectors are to be provided for external signal cable connection
4	Sheathing of RTD	Metal sheathed , mineral insulated, Compacted MgO packed
5	Calibration and accuracy	As per DIN-43670 Class-A for RTD
6	Stability	Zero & span drift within 0.1% of span for a 6 month period.
7	Characteristic	Linear with respect to temp. within $\pm 1/2$ percent of top range value
8	Standard	As per DIN-43670 for RTD & ASME PTC-19.3 for





S.N	Features	Minimum Requirements	
		Thermowell	
9	Accessories	a)	Adjustable Nipple-Union-Nipple with thermo well connection / plug in connectors
		b)	Compression fittings / unions
		c)	Flanges etc.
		d)	Thermowell as per requirement

- RTDs shall be of duplex, platinum three / four wire type with a nominal resistance of 100 ohms at 0°C and conform to DIN 43760 / BS 1904.
Stability of RTD over full range shall be better than 0.05 ohms and the repeatability figure shall be better than 0.02 ohms. Accuracy shall be of the order of 0.15% or better and response time shall be less than 20 seconds with thermo well.
- The protective-sheath material shall be SS 316, seamless tubes using compacted magnesium oxide packing for insulation. The insulation resistance at 540°C shall not be less than 5 mega-ohms.
- The time constant of the RTD shall suit the process requirements and shall be subject to approval of Owner / Consultant.

9.6 Metal Temperature Thermocouple

Table 9.5

Specifications for Metal Temperature Thermocouple

S.N	Features	Minimum Requirements
1	Measuring medium	Metal Temperature
2	Type	K-Type
3	Wire Gauge	16 AWG
4	No. of Element	Duplex with separate hot junctions, ungrounded type
5	Sheathing/Insulation/Dia.	Metal sheathed (SS 321) , mineral insulated (Magnesium oxide), ceramic packed, 8 mm Dia.
6	Bending Radius	30 mm (minimum)
7	Cold End Sealing	SS pot seal with color coded PTFE headed sleeve insulated flexible tails. Sealing compound - Epoxy Resin
8	Standard	ANSI MC 96.01.1975
9	Thermocouple Length	30 Mtrs. (minimum)
10	Accessories	1/2" NPT SS sliding end connector, weld pad, weld on clamps of heat resistant steel SS310.

- For metal temperature measurement, care shall be taken for proper contact with metal surface. The thermocouples sheath for metal temperature measurement shall have to be thermally insulated to avoid radiation /





- conduction / convection loss. Thermocouple assembly for metal temperature measurement shall suit the functional requirement.
2. The thermocouple shall be attached to the heater tube surface by being furnished with stainless steel welding pads or by the use of thermocouple attachment blocks. The multiple holes in these blocks shall allow for spare thermocouple element for quick replacement.
 3. For boiler metal temperature measurement, the lead wires shall have to be brought into nearest Junction Boxes which are located in accessible safe zones, using suitable protection pipes.
 4. For measurement of wall temperatures at boiler tubes, sheathed thermocouples, dia 3.0 mm NiCr-Ni single thermocouples shall be used. The thermocouple line shall be designed as Teflon-insulated stranded conductor, provided with glass filament insulation and stainless steel wire braiding. The thermocouple shall be welded to the compensation line outside of the boiler insulation, with the welding point spilled hermetically in a coupling element. The area of the boiler penetration shall be designed with an anti-kink spring of stainless steel and a line-fixing sleeve of stainless steel, encapsulated in synthetic resin.
 5. The differential temperature "inside / centre" of the wall shall be measured by means of sheathed thermocouples NiCr-Ni, dia 3.2 mm. For this special protective sleeve shall be used. Particular emphasis shall be put on compliance with the stipulated depth of the bores in the tube wall material.
 6. For SH, RH, metal temperature measurement thermocouples shall be provided as per the specification in Table 9.5.

9.7 Thermowell for Temperature Elements

1. The design of the thermo well shall take into consideration the temperature, pressure, medium and fluid velocity specified in the process in accordance with ASME Standard PTC 19.3, 1974.
2. Thermo wells shall, in general, be of SS 316 and shall be drilled from bar stock except for air and flue gas services. However, selection of thermo well material shall be as per following guideline.

Table 9.6A
Thermowell MOC Selection

S.N	Medium	MOC
1	Lignite-Air mixtures	SS 304
2	Flue gases	Black steel, SS 446
3	Preheater	Black steel, SS 446
4	Steam lines	SS 316 and pipe material compatible for high temperature steam
5	Water lines	Low carbon steel/ SS316
6	Boiler tubes	SS 304 / SS 309 / SS 310





3. Welded type thermo wells with 38 mm O.D. for welding & ½" NPT internal threads shall be used for pressure above 100 kg / sq cm or temperature above 400 deg C. Socket weld type thermo well with 34 mm O.D. for welding & ½" NPT internal thread, shall be used for pressure between 40-100 kg/cm² and temperature up to 400°C. Screwed type thermo wells with ½" NPT internal threads & M33X2 (M) outer threads shall be used for pressure below 40 kg/cm² and temperature below 400°C. For pipes having probability of prolonged vibration, seal welding may be done all around after tightening the thermo well within the base.
4. Thermocouples / RTD used in air / flue gas path shall be supported by suitable protection tube of adequate strength with welded cap at the end. The connection size of the temperature detector with the protection pipe shall be adjustable flange type, the ratings of which shall have to be approved by Owner / Consultant. The length of the protection pipe shall be such that it supports at a distance nearly 2/3rd length of the immersed temperature detector inside the duct using a heat insulated ring support in between. The protection pipe details shall have to be approved by Owner / Consultant during detailed engineering stage. If any support is necessary for protection pipe the Contractor shall have to arrange the same.
5. Thermo wells used in Mill classifier Outlet area shall be made of suitable material of sufficient abrasion resistance such as alloy cast iron / 'Ni-hard' / Tungsten Carbide of hardness approx. 400 BHN. The connection shall be flanged type, the details to be approved by Owner / Consultant. Protection rod in front of thermo wells for mill classifier if required shall be provided.
6. Thermo well manufacturing drawing covering material specification, dimensional details, details of special treatment, finish etc. as well as test procedure shall be subject to Owner's / Consultant's approval. Material certificate shall have to be furnished for each thermo well.
7. Wherever any approval is necessary from any recognized body / authority during manufacturing of high pressure wells, the same shall have to be arranged by the Contractor.
8. The thermo well immersion depth (U) shall be sufficient to eliminate conduction error. A general rule which may be followed is to use an immersion length equalling a minimum of 10 times the diameter of the protective tube or well. In general, immersion length of thermo wells for different line sizes shall be as follows:

Table 9.6B

Thermowell Immersion Length

S.N	Line Size	Immersion Length
1	From 4" to 6"	65 mm
2	From 8" & onwards	140 mm



64



**2x500 MW, NNTPP, Neyveli
CONTRACT SPECIFICATION
STEAM GENERATOR & AUX. PACKAGE - NTA1**



S.N	Line Size	Immersion Length
3	Vessels	400 mm

9.8 Pressure Gauge/ Differential Pressure Gauge/Draft Gauge

Table 9.7

Specification for Pressure Gauge/ DP Gauge/ Draft Gauge

S.N	Feature	Minimum Requirement
1	Type	Bourdon / Bellows / Diaphragm
2	Sensing Element Material	AISI 316 SS
3	Movement Material	AISI 304 SS
4	Case Material / Protection Class	AISI 304 SS / IP 65
5	Dial Size	150 mm For Special application like drum pressure, Main Steam pressure etc. 250 mm shall be used
6	Scale	Black lettering on white background in 270 °C arc
7	Range Selection	Normally operate at 75% of its maximum pressure range. Instruments measuring varying pressures shall operate in a band of 60% of its maximum pressure range.
8	Over range Protection	130% of maximum range by internal stop. External stop below zero.
9	Adjustment	External Micrometer screw for zero adjustment. Internal micrometer screw for range adjustment.
10	Stop at Max. Reading	Shall be provided
11	Element Connection	Argon welding
12	Process Connection	½" NPT(M) bottom connection for local mounting, back connection for flush panel mounting
13	Accuracy	+/- 1.0 % of full scale or better
14	Operating Ambient Temperature	50 °C (Max. continuous)
15	Safety Feature	Neoprene Safety Diaphragm (Blowout disc) at the back
16	Window	Shatter-proof glass
17	Chemical Seal Unit	SS 316 Flange and Diaphragm, PTFE coated / block, Silicon Oil filling fluid
18	Accessories	Snubbers for pulsating fluid applications / 3-way gauge cock / 2-valve manifold / Pigtail / Siphon for steam service / Gauge Saver, if maximum or Design Pressure is very high than the Operating Pressure / Counter Flanges / Bolts, Nuts, Gaskets / SS Tag Plate

1. Directly connected pressure measuring instruments shall be diaphragm, bourdon or bellow type elements depending upon the services conditions. In





general, diaphragm elements shall be used in the range of 0 to 1000 mm water column pressure, bellow type element for ranges of 0 to 1 Kg/cm² and bourdon type element for ranges greater than 1 Kg/cm².

2. Primary element material shall be corrosion resistant to process fluid or diaphragm seals shall be provided for protection.
3. For draft measurement Teflon coated beryllium copper diaphragm shall be used.
4. Snubbers shall be floating pin type, externally mounted and externally adjustable. It shall be used for all pulsating services.
5. Diaphragm seals, filled type or mechanical type shall be furnished where plugging of the element may occur or where suitable material is not available in highly corrosive services. When chemical seals are required, they shall be the clean out type with flushing connection.
6. Over-range protection shall be provided to at least 130 % of range. For vacuum service, the element shall have under-range protection to full vacuum
7. Ranges of the gauges shall be so selected that the gauge normally operates in the middle third of the scale and conform to IS 3624 standard dials, wherever necessary.
8. The sensing elements for all gauges shall be properly aged and factory tested to remove all residual stresses and shall be SS 316 with forged socket and tip of the same material. Elements above 70 Kg/sq. cm range shall be bored instead of drawn.

9.9 Temperature Gauge

Table 9.8

Specification for Temperature Gauge

S.N	Feature	Minimum Requirement
1	Type	Mercury filled
2	Sensing Element material	Bourdon AISI 316 SS
3	Movement Materials	AISI 304 SS
4	Case Material/Protection class	SS 304/ IP65
5	Capillary Armouring	SS Flexible
6	Capillary	SS 316 (5 mtr. Length for Local & 15 metre for panel Mounting)
7	Bulb/Stem Diameter	12 mm or 6 mm uniform
8	Dial Size	150 mm
9	Window	Shatterproof glass
10	Scale	Black lettering on white background in 270 °C arc
11	Adjustment	Micrometer screw for zero adjustment. Internal micrometer screw for range adjustment.
12	Pointer	Externally Adjustable



S.N	Feature	Minimum Requirement
13	Range Selection	Normal Process Temperature – approximately two third of Temperature range.
14	Stop at Max. Reading	Shall be provided
15	Over range Protection	130% of FSD
16	Instrument Connection	Bottom connection for local mounting, back connection for flush panel mounting.
17	Process Connection	½" NPT with Thermowell
18	Performance :-	
a	Accuracy	+/-1.0% of full scale or better
b	Repeatability	Less than 0.5% of full range
c	Response Time	30 seconds (max.) with Thermowell and 15 seconds Bare.
15	Operating Ambient Temperature	50 °C (Max. continuous)
16	Accessories	Mounting brackets, Bolts, Nuts, Gaskets / SS Tag plate, SS Thermowell etc.

- Temperature gauges shall be dial thermometers (liquid spring / steam pressure spring / metal expansion thermometer), either rigid stem or capillary tube depending upon application; if this is not possible for design reasons, industry type liquid – in – glass thermometers shall be used.
- Case shall have back or bottom connection with adjustable gland to permit adjustment of thermometer into the thermo well.
- Thermometer stem adjustable gland with union connection and bushing shall be suitable for ½ inch NPT connection.
- Bi-metallic type dial thermometer, if used, shall be hermetically sealed, back or bottom connection type, with 150 mm dial.
- The gauges shall be provided with automatic ambient temperature compensation.
- Scale ranges shall be selected so that normal process temperature is in middle two – third of full scale range

9.10 Level Gauge

Table 9.9A

Specification for Gauge Glass Type Level Gauge for vessels

S.N	Feature	Minimum Requirement
1	Sensing Element & material	Tempered toughened Borosilicate gauge glass steel Armored reflex or transparent type
2	Body Material	Forged carbon steel / 304 SS
3	End Connection	Process connection as per ASME PTC and drain / vent 15 NB



S.N	Feature	Minimum Requirement
4	Accuracy	+/- 2 % of full scale
5	Scale	Linear vertical
6	Range Selection	Cover 125 % of max. of scale
7	Over Range Test	Test pressure for the assembly shall be 1.5 time of the Maximum design pressure at 38 degree C
8	Housing	CS / 304 SS leak - proof
9	Identification	Engraved with service legend or or laminated phenolic Name plate
10	Packing	PTFE Teflon
11	Illumination	220 V, 50 Hz, 25 / 40 Watts either with deflector or diffuser (for transparent type level gauge) / 220V , 50 Hz, 25 /40 Watts with red and green filter for bicolor gauge
12	Accessories	Gasket for all KEL - F shield for transparent type vent and drain valves of CS / SS as per requirement
13	Others	Anti - Frost extension for low temperature service. Heating / cooling arrangement

- Level gauges shall be steel armoured reflex or transparent or bi -colour type, top and bottom connection as per pressure vessel standard of ASME PTC code and 15 mm NB (1/2 inch NPT) Drain and Vent connection.
- Body material and cover material shall normally be forged carbon steel, 304 stainless steel or other superior material.
- Reflex type gauges shall be used for clean and colorless liquids and transparent type for other liquids. For boiler and condensate services, treated water, the transparent type with KEL - F shields shall be used to avoid their attack on the glands.
- The gauge glass must have a rating equal to or more than the vessel design pressure and temperature. The test pressure for the complete design gauge assembly shall be as per Owner's / Consultant's recommendation.
- The maximum length of a single gauge glass shall not exceed 1400 mm. Where large range is required, multiple gauges of preferably equal lengths shall be used with 50 mm over - lapping in visibility.
- The visibility shall cover the operating level range and the maximum and minimum ranges expected considering start - up conditions as well as alarm and shut down points. Internal heating shall be provided for viscous liquids. Integral illuminators shall be used for transparent gauges, if necessary.
- Stand - pipes shall be used for multi - gauge glass and level controller installation and on horizontal drum or exchanger with top and bottom connections to have visibility of the complete span. The stand pipe shall not be used with block valves.
- Primary isolation valves shall be used In addition to the gauge glass valves unless otherwise specified. When the process fluid may create lugging or



- leakage problem, gauge valves may be omitted. For low temperature liquid having high vapour pressure at ambient temperature, isolation and gauge valves shall not be permissible. Safety valve shall be provided at the vent connection of the gauge glass where isolation is required.
9. For high pressure service such as boiler water etc., the gauge glass shall be multi - port illuminated type (Bi - colour type). Indication of water space shall be 'green' and indication of steam space shall be 'red'.
 10. Bi - colour level gauges shall have following features:
 - Temperature equalizing column expansion bend and chain patterned hand - wheel
 - Certification by Inspectorate of Boiler

Table 9.9B

Specification for Float & Tape Type Level Gauge for Tanks

S.N	Feature	Minimum Requirement
1	Type	Float & Tape type
2	MOC of Float & Tape	SS 316
3	MOC of Pulley	Aluminium
4	Guide Wire	SS 316
5	Accuracy	+/- 5 mm
6	Indication	Arrow on Circular or Vertical scale Board

9.11 Pressure/ Differential Pressure Switch

Table 9.10

Specification for Pressure/DP Switch

S.N	Feature	Minimum Requirement
1	Type	Piston for high pressure application Bellow/Diaphragm for low pressure application
2	Sensing Element material	AISI 316 SS
3	Wetted Parts material	AISI 316 SS
4	Case Material	Epoxy coated Die Cast Aluminium
5	Setter Scale	Black graduation on white linear scale. Graduation 0 - 100% with red pointer for set points.
6	Over range for Pressure / Vacuum Switch	130% of maximum pressure
7	Set Point	Adjustable throughout switch operating range.
8	Static Pressure for Differential Pressure Switch	Maximum Line Pressure or Static Pressure on either side without permanent deformation or loss of accuracy.
9	Adjustments	Internal - set point



S.N	Feature	Minimum Requirement
		Differential adjustable feature
10	Process Connection	½" NPT(M) bottom connected
11	Switch Configuration	2 SPDT / 1 DPDT
12	Switch Rating	230 V, 5A AC / 220 V, 0.25 A DC/24 V, 2A DC
13	Switch Type	Snap acting, shock and vibration-proof
14	Cable Connection	½" ET conduit connections or compression gland
15	Enclosure Class	Weather proof as per IP 65 with corrosion resistance coating.
16	Accuracy	1% of span up to 3Kg/cm2 0.5% of span for more than 3 Kg/cm2.
17	Repeatability	0.5% of span
18	Accessories	
a)		Snubbers for pulsating fluid application.
b)		Tag Number, service engraved in SS tag plate
c)		Teflon back-up sheath protection, as required.
d)		i) Remote diaphragm seal with SS 316 armored capillary for typical application. MOC of seal material shall be as per process fluid requirement. ii) Silver coated diaphragm for corrosive services like chlorinated water.
e)		Retention ring and screws for surface mounting.
f)		3-way Gauge Cock (SS 316) for PS / 5-Valve Manifold (SS 316) for DPS.
g)		Mounting bracket / Clamp for 2" pipe, bolt & nut.

- The pressure switches shall have sensing elements made of copper alloy or stainless steel sealed diaphragm and piston actuated for high pressure service and bellows for low pressure / vacuum service.
- Low differential pressure switches for low static pressure ranges shall be diaphragm type with snap action switch elements.
- Low differential pressure switches for high static pressure shall be elbows and torque tube type and snap - action switch elements and metric scale dial indicators.
- For corrosive, viscous process fluids diaphragm sealed with completely filled inert liquid shall be provided. Material of diaphragm and wetted parts shall be selected considering the nature of process fluid.
- The sensing elements shall be properly aged and factory tested to remove all residual stresses. They shall be able to withstand at least 130 % the full scale pressure without any damage or permanent deformation.
- Actuation set point, dead band shall be internally adjustable throughout the range with tamper proof facilities.
- Electrical connection for the switch devices shall be suitable for plug in type connection.





8. Process connection shall be ½ inch NPT. Process piping connections shall include necessary union, nut, nipple, tail pipe, isolation valve and test connection to permit servicing, testing, calibration and removal of the instrument device.
9. Instrument for steam & hot water service, shall be connected through siphon, of stainless steel or suitable material. Pulsation dampeners shall be provided for all pulsating fluids.
10. Pressure switches shall be tested as per BS – 6134.

9.12 Conductivity Type Level Switch

Table 9.11

Specification for Conductivity Type Level Switch

S.N	Feature	Minimum Requirement
1	Sensing elements	Conductivity type
2	Material	SS 316
3	Repeatability	± 0.5 % of full range or better
4	Accuracy	± 0.5 % of full scale or better
5	Working temperature	As per process requirement
6	Probe length	As per requirement
7	Mounting	Flanged- on external cage
8	No. of contact	2 NO. + 2 NC, SPDT, snap action type dry contact
9	Rating of contacts	5A, 240 V AC / 2A, 24 V DC / 0.25 A, 220V DC
10	Enclosure	IP 65
11	Housing	Cast aluminum epoxy coated weather proof
12	Ambient Temperature	60°C (max.)
13	Electrical Connection	Plug-in type
14	Cable connection	½ " NPT with cable gland
15	Set point	Adjustable
16	Accessories	All mounting accessories

9.13 Capacitance Type Level Switch

Table 9.12

Specification for Capacitance Type Level Switch

S.N	Feature	Minimum Requirement
1	Type	Capacitance type
2	Probe	Rod or Suspended Electrode
3	Material	SS 316
4	Insulation	PTFE/PP/Kynar part/full as required
5	Repeatability	± 0.5 % of full range or better
6	Accuracy	± 0.5 % of full scale or better

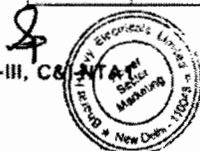



9.18 Flow Switch

Table 9.17

Specification for Flow Switch

S.N	Feature	Minimum Requirement
1	Type	Vane actuated/Differential bellow type
2	Vane/bellow Material	SS 316
3	Repeatability	± 0.5 % of full range or better
4	Accuracy	± 0.5 % of full scale or better
5	Working temperature	As per process requirement
7	Process connection	As per requirement
8	Over-range proof	150% of max. design pressure
9	No. of contact	2 NO. + 2 NC, SPDT, snap action type dry contact, shock & vibration proof
10	Rating of contacts	5A, 240 V AC / 2A, 24 V DC / 0.25 A, 220V DC
11	Enclosure	Cast Aluminium/IP 65
12	Cable connection	Compression type cable gland/ ½" NPT Conduit connection
13	Electrical Connection	Plug-in socket
14	Accessories	All mounting accessories

9.19 Rotameter

Table 9.18

Specification for Rotameter

S.N	Feature	Minimum Requirement
1	Type	Variable area Linear scale
2	Fluid media	Water/Oil
3	Float Material	SS 316
4	Accuracy	± 2 % of full scale or better
5	Working temperature	0 to 70°C
6	Process connection	As per requirement
7	Over-range proof	150% of max. design pressure
8	Enclosure	Transparent toughened glass/IP 65
9	Accessories	Flange, orifice in case of bypass Rotameter

Rotameter shall be used for low flow & low viscosity applications of liquid.

9.20 Coriolis Flow meter

Table 9.19

Specification for Coriolis Flow meter

S.N	Feature	Minimum Requirement
1	Service	Fuel Oil (LDO/HFO) flow measurement





S.N	Feature	Minimum Requirement
2	Primary Element	Flow tube of SS316 or better
3	Heating arrangement	Integral with flow element
4	Temperature control	To be provided
5	Allowable pressure drop	< 0.5 Kg/Sq. cm.
6	End Connection type /size	Flanged WMRF to ANSI 300
7	Cable entry	1/2" NPT (F)
8	Accuracy	+/- 0.2% of Flow rate or better
9	Power supply	230 V 50 Hz
10	Drain	Self draining facility
11	Enclosure	SS 316
12	Display	LCD display
13	Output	2 nos. isolated output of 4-20 mA.
14	Load	< 750 ohms
15	Turn down Ratio	100:1
16	Housing	IP 65 or better
17	Hazardous duty Version	FM standard
18	Accessories	Counter flanges, Nuts, Bolts, Gaskets, U clamps, prefab cables etc.

9.21 Sight Glass Indicator (Flow Glass)

Table 9.20
Specification for Flow Glass

S.N	Feature	Minimum Requirement
1	Application	Online observation of fluid flow in Pipeline
2	Type	Double window for pressurized pipe with rotary wheel for installation in horizontal or vertical pipeline. Full view for non-pressurized pipeline.
3	Size	Double window up to 12" and 600 lbs rating. Full view up to 6" and 150 lbs rating.
3	Body Material	SS 316
4	Glass	Pyrex tempered glass
	Others	Rotor & wetted parts shall be bronze All accessories shall be SS316
5	Protection class	IP-65
6	Connection	Screwed up to 50 NB size Flanged ANSI 150 RF - above 50 NB size
7	Accessories	Name plates, mating flanges with gasket, bolts & nuts etc.

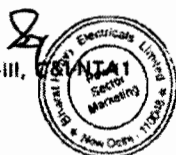



Table 9.28

Specification for Speed Transmitter

S.N	Feature	Minimum Requirement
1	Type	Microprocessor based Programmable
2	Enclosure Protection	IP-67
3	Accuracy	+/- 1 RPM
4	Power Supply	24 V DC
5	Range	Programmable
6	Resolution	0.1 RPM
7	Output	4-20 mA
8	Input signal	Pulse Input from Proximity Probe
9	Display	LCD display

Table 9.29

Specification for Flow/No Flow detector switch

S.N	Feature	Minimum Requirement
1	Operating Principle	Microwave
2	Detection Range	Adjustable
3	Power Supply	230 V AC, 50 Hz
4	Housing	SS 316
5	Protection Class	IP 67
6	Output	Potential free contact output
7	Contact Rating	5A, 240 V AC; 0.5A, 220 VDC
8	Time delay for contact Changeover	Adjustable
9	Accessories	All required mounting accessories

9.28 Solenoid Valves

Table 9.30

Specification for Solenoid Valves

S.N	Feature	Minimum Requirement
1	Operating Principle	Electromagnetic (noiseless), Pilot operated
2	Coil Voltage Rating	24 V DC (in general)/220 V DC/230 V AC/ 110 V AC as required
3	Ways	3 ways in general others as required
4	Port size	¼ " NPT all ports
5	Body	SS Bar stock/Brass



S.N	Feature	Minimum Requirement
6	Trim	AISI 316 SS
7	Manual Operation	In built
8	Duty	Suitable for continuous Energisation
9	Sealing	Airtight & leak proof
10	Coil Enclosure	SS 316/Moulded type
11	Insulation class	Class H
12	Coil Casing	IP-67
13	Mounting	Suitable for mounting On pipe or in panel
14	Cable connection	½" NPT Cable gland
15	Accessories	Mounting Bracket, nuts, bolts etc.
16	Other Features	LED Indication

9.29 Dew Point Meter

Table 9.31

Specification for Dew Point Meter

S.N	Feature	Minimum Requirement
1	Type	Sensor- Hyper Thin Film high capacitance Al2O3, Transmitter- Microprocessor based 2-wire loop powered
2	Accuracy	± 5.5°F (± 3°C)
3	Repeatability	± 0.9°F (± 0.5°C)
4	Storage temperature	-40°F to + 176°F (-40°C to + 80°C)
5	Local Indication	To be provided
6	Input Resolution	0.1°C dew point
7	Power Supply	24 VDC
8	Output	4 - 20mA
9	Enclosure material	Die - cast Aluminium
10	Enclosure protection	Weatherproof IP 65
11	Electrical connections	½ " NPT
12	Process connection	As per requirement
13	Accessories	All required mounting accessories.

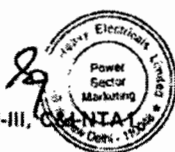



10. PROCESS CONNECTION PIPING

The Contractor shall provide, install and test all required material for completeness of impulse piping system, sample piping system and air piping system as per the requirements of this clause on as required basis for the connection of instruments and control equipment to the process and make the system complete. However, the Contractor shall furnish during detailed engineering all relevant drawings, material and technical specifications of various items service wise for Owner/Consultants approval.

Control and instrument piping & connections shall generally be designed in accordance with the following criteria and these criteria shall be closely co-ordinated with Mechanical Piping Contractor / Erector to fulfill the Mechanical Design Criteria also. This is a guideline for Piping design & selection. OEM standard proven practice in these regard are also acceptable if it is complying with applicable international standard.

1. Pressure connections and piping up to the root valves for all pressure indicators, pressure switches, pressure transmitters, etc., shall be as indicated for miscellaneous piping.
2. Temperature indicators, temperature controllers, temperature switches, temperature detectors, and test well connections shall be as follows:
 - Main steam -- 40 mm NPT.
 - Extraction steam -- 40 mm NPT.
 - Boiler feed water -- 32 mm NPT.
 - Reheat steam -- 40 mm NPT.
 - Duct temperatures -- 25 mm NPT.
 - All others -- 19 mm NPT.
3. Draft pressure connections on steam generator walls and ducts shall be 50 mm pipe couplings.
4. Flow transmitter connections and piping up to the root valves shall be 25 mm for all piping except orifice flanges, where 15 mm piping and valves shall be used.
5. Level switch connections and piping up to root valves shall be 25mm.
6. Level controllers and level transmitters of the displacement type shall have connections and piping up to root valves of 50 mm.
7. Level controllers and level transmitters of the differential pressure type shall have connections and piping up to root valves of 25 mm.
8. Instrument columns at tanks and pressure vessels shall generally be 65 mm minimum.

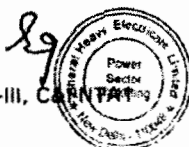



10.1 Design Pressure and Temperature

Instrument primary piping design pressure and temperature shall be selected consistent with the requirements discussed in Mechanical Design Criteria of this specification, for the process pipe to which the instrument primary piping is connected. The following general criteria shall also apply:

Instrument primary piping for steam and other systems shall be designed for 1-½ times the maximum sustained process pressure and temperature (plus 20°C).

10.2 Sizes of Instrument Primary Piping

Instrument primary piping shall not be smaller than the connection at the process pipe root valve and/or the following (metric sizes are nominal):-

1. 20 mm for pressure measurement piping with a design pressure equal to or less than 42.0 bar and a design temperature equal to or less than 400°C.
2. 25 mm for pressure measurement piping with a design pressure greater than 42.0 bars or a design temperature greater than 400°C.
3. Flow and level measurement by differential pressure shall also use primary piping conforming to the above requirements; however, flange tap connections may be of 13 mm size.
4. Float actuated level switch devices shall be supported on connecting piping not smaller than 25 mm.
5. Level controllers and transmitters of the displacement float type shall be supported on connecting piping not smaller than 50 mm.
6. Instrument columns for float actuated level switches and displacement float devices shall be piping of not less than 65 mm.
7. Primary piping internal diameter shall not be less than 8 mm between the process connection and instrument blow down valve.

10.3 Materials for Instrument Primary Piping

Material for instrument primary piping connecting to the root valve shall preferably be the same as that used in the process system to which it is connected. Higher strength materials may be substituted in the interest of standardization; however, welding procedures at the point of joining the instrument primary piping to the process piping must be appropriate to the combination of materials involved. Copper may be used only for compressed air services that use copper process piping.

10.4 Insulation of Instrument Primary Piping

Instrument primary piping connecting to high temperature systems, which might become hot enough to injure personnel during blow down of the



instrument line, shall be insulated where such hazard exists. Insulation materials, exterior finish, and metal lagging shall conform to the standards adopted for the process piping.

All materials supplied shall be suitable for intended service, process, operating conditions and type of instruments used and shall fully conform to the requirements of this specification. The material offered by the Contractor shall be from reputed, proven manufacturer.

10.5 Process Connection Size

Size of tapping point, Stub No. and size of Root valves for different type of measurements.

These shall be as follows:

**Table 10.1
Process Connection Stub & Root valve**

S. N.	Quantity of root valves (Nos.)	Size of stub and root valves	Service condition
A. Pressure and Differential pressure measurement			
1	2	25NB	> = 62 bar or 425degree C
2	1	15NB	< 62 bar and 425 degree C
B. Level Gauge and Switch			
1	2	25 NB	> = 62 bar or 425 degree C
2	1	25NB	< 62 bar and 425 degree C
C. Level Transmitter (Displacement Type)			
1	2	40NB	> = 62 bar or 425degree C
2	1	40NB	< 62 bar and 425 degree C
D. Stand pipe for Level measuring instrument			
1	2	80 NB	> = 62 bar or 425degree C
2	1	80 NB	< 62 bar and 425 degree C
E. Flow measurement			
1	2	25NB	> = 62 bar or 425degree C
F. Level measurement			
1	1	25NB	< 62 bar and 425 degree C





S.N	Property	Requirement
8	Test	Flare, Hardness, Ball & Bubble test
9	Standard Length	5 metre

Table 10.6

Specification for Seamless SS Tube Fittings

S.N	Property	Requirement
1	Reference	ASTM A-182
2	Material Grade	SS 316 forged
3	Type	Double ferrule double compression
4	Ferrule	SS 316
5	Size	To suit SS tubing & NPT end connection
6	Type of fittings	Male/Female connectors, elbow, Equal & Unequal Tee, Cross, Straight connector, bulk head unions, etc. as required to suit the installation.

Table 10.7

Specification for Instrument Valve Manifolds

S.N	Property	Requirement
1	Type	Two valve manifold/Three Valve Manifold Five valve manifold
2	Mounting	Remote 2" pipe mounting
3	Construction	Single Block (Bar Stock)
4	Material	Forged body & bonnet AISI 316 SS
5	Ports	½" NPT
6	Rating	420 Kg/ cm ² at ambient
7	Packing	PTFE Wafer
8	Seat & Stem	AISI 316 SS
9	Plug	AISI 316 SS free to turn on stem/ 17-4 PH
10	Handle	AISI 316 SS
11	Connection	Straight
12	Accessories	Plug for all ports Mounting Bracket, nut, bolts etc.

Table 10.8

Specification for Condensate Pot

S.N	Property	Requirement
1	Reference	ASTM A 182 F22/ ASTM A105
2	Material	Alloy Steel/Carbon Steel as per application
3	Construction	Drilled Bar stock
4	End Connection	3 nos. ½" SW



S.N	Test Requirement	Standard
2	Core Concentricity	IEC 793-1-A3
3	Macro Bending	EIA/TIA-455-62A (IEC 793-1-C11)
4	Micro Bending	IEC-793-1-C3
C	Proof Test	IEC-793-1-B1
D	Strippability	IEC-793-1-B6
E	Visual Examination	EIA/TIA-455-13 (IEC 793-1-B5)

11.4 Instrumentation Cable Interconnection & Termination Philosophy

The cable interconnection philosophy to be adopted shall be such that expensive grouping of signals by large scale use of field mounted Group Junction Boxes (JBs) at strategic locations. (where large concentrations of signals are available, e.g. valves limit and torque switches, switchgear) is done and consequently cable with higher number of pairs are extensively used. The details of termination to be followed are mentioned in the following Table:

Table 11.5

Instrumentation Cable Interconnection & Termination Philosophy

S.N	Application		Type of Termination		Type of Cables
	From (A)	To (B)	End A	End B	
1.	Limit, Torque switches of valves / dampers / drives (integral junction box)	Marshalling cubicle / Marshalling cum Termination Cubicle / Local group JB	Plug-in connector	Posts mount cage clamp type	G
2.	Transmitters, E/P converters, process actuated switches mounted in LIE / LIR	Integral junction box of LIE / LIR	Plug-in connector	Cage clamp (rail mount)	F, G
3.	RTD heads	Local junction Box	Plug-in connector	Cage clamp (Rail mount) type	F
4.	Thermocouples	Junction Box	Plug in connector	Cage clamp (Rail mount) type	A, B, C*
5.	Other Field Mounted Instrument	Local JB / Group JB	Plug in connector	Screwed, Cage clamp (Rail mount) type	F (For analog signals) G (For Binary Signals)
6.	Junction Box (For	Marshalling Cubicle /	Cage clamp (Rail mount)	Screwed, Cage clamp (Rail	A, C*. These



56



2x500 MW, NNTPP, Neyveli
CONTRACT SPECIFICATION
STEAM GENERATOR & AUX. PACKAGE - NTA1



S.N	Application		Type of Termination		Type of Cables
	From (A)	To (B)	End A	End B	
	Thermocouples for interlock and protection	Marshalling cum Termination Cabinet	type	mount) type	signals shall preferably through 6 pair cable
7.	Local junction box, Instrument Junction box of LIE / LIR / Group JB / MCC / SWGR	Group JB	Cage clamp (Rail mount) type	Cage clamp (Rail mount) type	F, G
8.	Local junction box, Instrument Junction box of LIE / LIR / Group JB / MCC / SWGR	Marshalling Cubical / Marshalling cum termination Cabinet	Cage clamp (Rail mount) type	Posts mount cage clamp type	F, G
9.	Marshalling Cubical / Termination Cabinet	Electronic system cabinet	Cage clamp post mounted type	Plug-in connector / Other System as per manufacturer's Standard	Internal Wiring

Notes:

1. Normally 10% spare cores shall be provided when the numbers of pairs of cables are more than four pairs.
2. For analog signals, individual pair shielding & overall shielding & for binary signals only overall shielding of instrumentation cables shall be provided.
3. * For high temperature applications only.
4. Instrument Cabling for instruments / equipment of specialized / proprietary Control System shall be as per manufacturer's standard.

11.4.1 Terminal Blocks

1. All terminal blocks shall be rail mounted/post mounted, cage clamp type with high quality non-flammable insulating material of melamine suitable for working temperature of 105 deg. C. The terminal blocks in field mounted junction boxes, temperature transmitters, instrument enclosures/racks, etc. shall be suitable for cage clamp connections. The terminal blocks in Control Equipment Room logic / termination / marshalling cubicles shall be suitable for the post mounted cage clamp connection at the field input end. The terminal blocks for

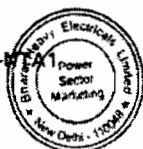



5. DESIGN CRITERIA

This section covers the general design criteria to be adopted in designing the Control & Instrumentation system for the SG Package.

5.1 General Requirements

5.1.1 Ambient Conditions

Instruments, devices and equipment for location in outdoor / indoor / air-conditioned areas shall be designed to suit the environmental conditions indicated below and shall be suitable for continuous operation in the operating environment of a Lignite fired Power plant and also during periods of air conditioning failure without any loss of function, or departure from the specification requirements covered under this specification.

Table 5.1
Protection Class Requirement

Ambient Temperature (outside temperature)	Pressure	Relative Humidity	Atmosphere	Required Protection class of panels /cabinets /desks to be provided by Contractor
Outdoor Location				
55 °C max	Atmosphere	100%Max	Air (dirty)	IP 65
4 °C min	Atmosphere	5% Min	Air (dirty)	IP 65
Indoor Location				
55 °C max	Atmosphere	95% Max	Air	IP 54^^
4 °C min.	Atmosphere	5% Min	Air	IP 54^^
Air-conditioned Area				
24 +/- 2 °C normal	Atmosphere	95% Max	Air	IP 42
50 °C Max. ^	Atmosphere	5% Min	Air	IP 42
^ During Air Conditioning failure				
^^ For non-ventilated enclosures. For Ventilated enclosures, protection class shall be IP 42.				
1. For hazardous areas the protection class shall be in accordance with the requirements of the relevant NEC code for the location.				
2. For PCs, OWS, EWS, Servers, Printers and other peripherals, maximum temperature limit shall be 35 °C. For LVS the same shall be 25 °C & for UPS the same shall be 40 °C				

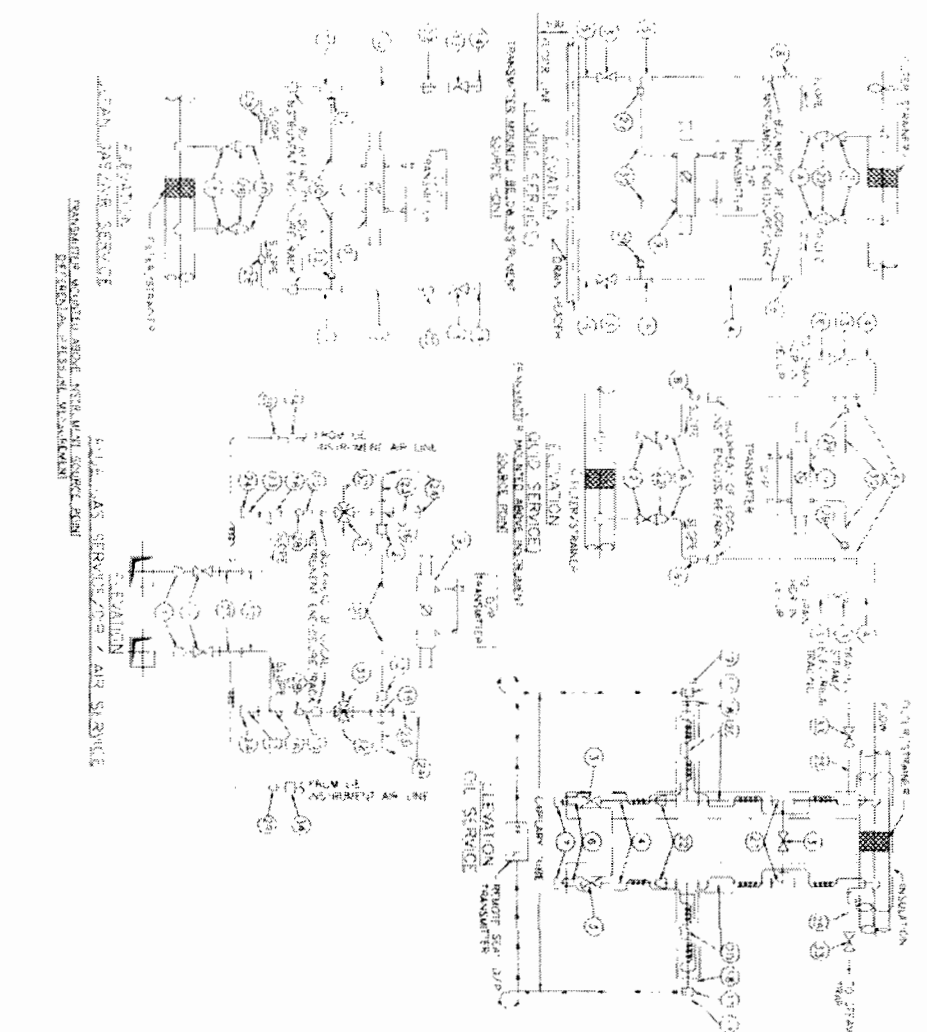

MECHANICAL SYSTEMS
 MECHANICAL SYSTEMS
 MECHANICAL SYSTEMS

NO	DESCRIPTION
1	1/2" SW. GALV. SHEET
2	1/2" SW. GALV. SHEET
3	1/2" SW. GALV. SHEET
4	1/2" SW. GALV. SHEET
5	1/2" SW. GALV. SHEET
6	1/2" SW. GALV. SHEET
7	1/2" SW. GALV. SHEET
8	1/2" SW. GALV. SHEET
9	1/2" SW. GALV. SHEET
10	1/2" SW. GALV. SHEET
11	1/2" SW. GALV. SHEET
12	1/2" SW. GALV. SHEET
13	1/2" SW. GALV. SHEET
14	1/2" SW. GALV. SHEET
15	1/2" SW. GALV. SHEET
16	1/2" SW. GALV. SHEET
17	1/2" SW. GALV. SHEET
18	1/2" SW. GALV. SHEET
19	1/2" SW. GALV. SHEET
20	1/2" SW. GALV. SHEET
21	1/2" SW. GALV. SHEET
22	1/2" SW. GALV. SHEET
23	1/2" SW. GALV. SHEET
24	1/2" SW. GALV. SHEET
25	1/2" SW. GALV. SHEET
26	1/2" SW. GALV. SHEET
27	1/2" SW. GALV. SHEET
28	1/2" SW. GALV. SHEET
29	1/2" SW. GALV. SHEET
30	1/2" SW. GALV. SHEET
31	1/2" SW. GALV. SHEET
32	1/2" SW. GALV. SHEET
33	1/2" SW. GALV. SHEET
34	1/2" SW. GALV. SHEET

FOR CONTRACT PURPOSE ONLY

053

MEYBEL LIGHT CORPORATION LTD MEYBEL TANJUNGPURA

LANEYER ENGINEERING CONSULTING ENGINEERS

NO	REVISION	DATE
1	ISSUED FOR TENDER	11-11-2011
2	FOR CONTRACT PURPOSE ONLY	11-11-2011

PRESSURE MEASUREMENT

[SYSTEM PRESSURE CONNECTION DETAIL 0000]

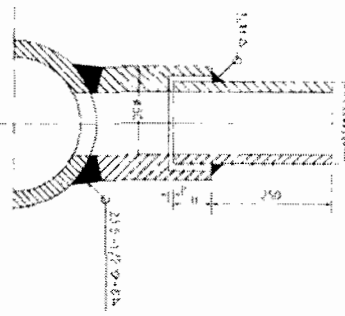

[SYSTEM AIR PNEUMATIC DETAIL 0000]

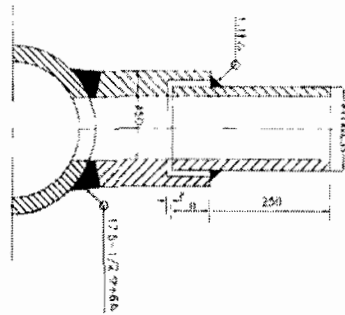

[SYSTEM PRESSURE CONNECTION DETAIL 0000]

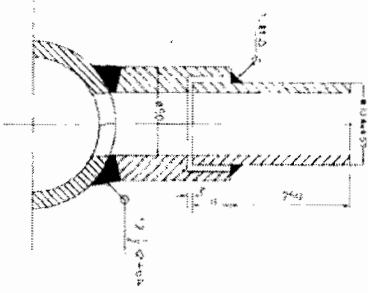

[SYSTEM AIR PNEUMATIC DETAIL 0000]

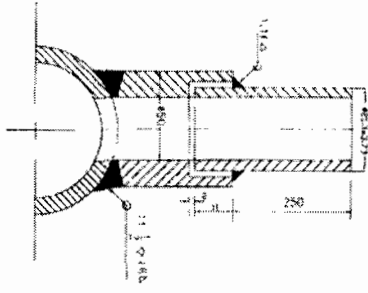

- NOTES:
1. MATERIAL OF THE BOSS AND NUTS OF THE SAME AS THE PIPE AND WELDS.
 2. THE LENGTH OF THE WELDS SHOULD BE 250mm.
 3. THE OTHER END OF THE WELDS SHALL BE SEPARATED WITH 1" CLEARANCE.
 4. THE WELDS SHALL BE MADE TO BE EXACTLY THE SAME AS THE WELDS OF THE PIPE.
 5. THE WELDS SHALL BE MADE TO BE EXACTLY THE SAME AS THE WELDS OF THE PIPE.
 6. THE WELDS SHALL BE MADE TO BE EXACTLY THE SAME AS THE WELDS OF THE PIPE.
 7. THE WELDS SHALL BE MADE TO BE EXACTLY THE SAME AS THE WELDS OF THE PIPE.
 8. THE WELDS SHALL BE MADE TO BE EXACTLY THE SAME AS THE WELDS OF THE PIPE.
 9. THE WELDS SHALL BE MADE TO BE EXACTLY THE SAME AS THE WELDS OF THE PIPE.
 10. THE WELDS SHALL BE MADE TO BE EXACTLY THE SAME AS THE WELDS OF THE PIPE.



057

FOR CONTRACT PURPOSE ONLY

NO.	REV.	DATE	DESCRIPTION
1			
2			
3			
4			
5			

MEYVELL LIGHTING CORPORATION LTD, MEYVELL, TAMIL NADU

LAABHTE
INTERNATIONAL
CONSULTING ENGINEERS, CHENNAI, INDIA

27 ABU NAYYAN STREET
FOURTH FLOOR
MEYVELL, TAMIL NADU

INSTRUMENT SOURCE CONNECTION
DETAILS - PRESSURE MEASUREMENT

PROJECT NO: 14-05-11
DATE: 14-05-11

PROJECT NO: 14-05-11
DATE: 14-05-11
DRAWING NO: 14-05-11-01

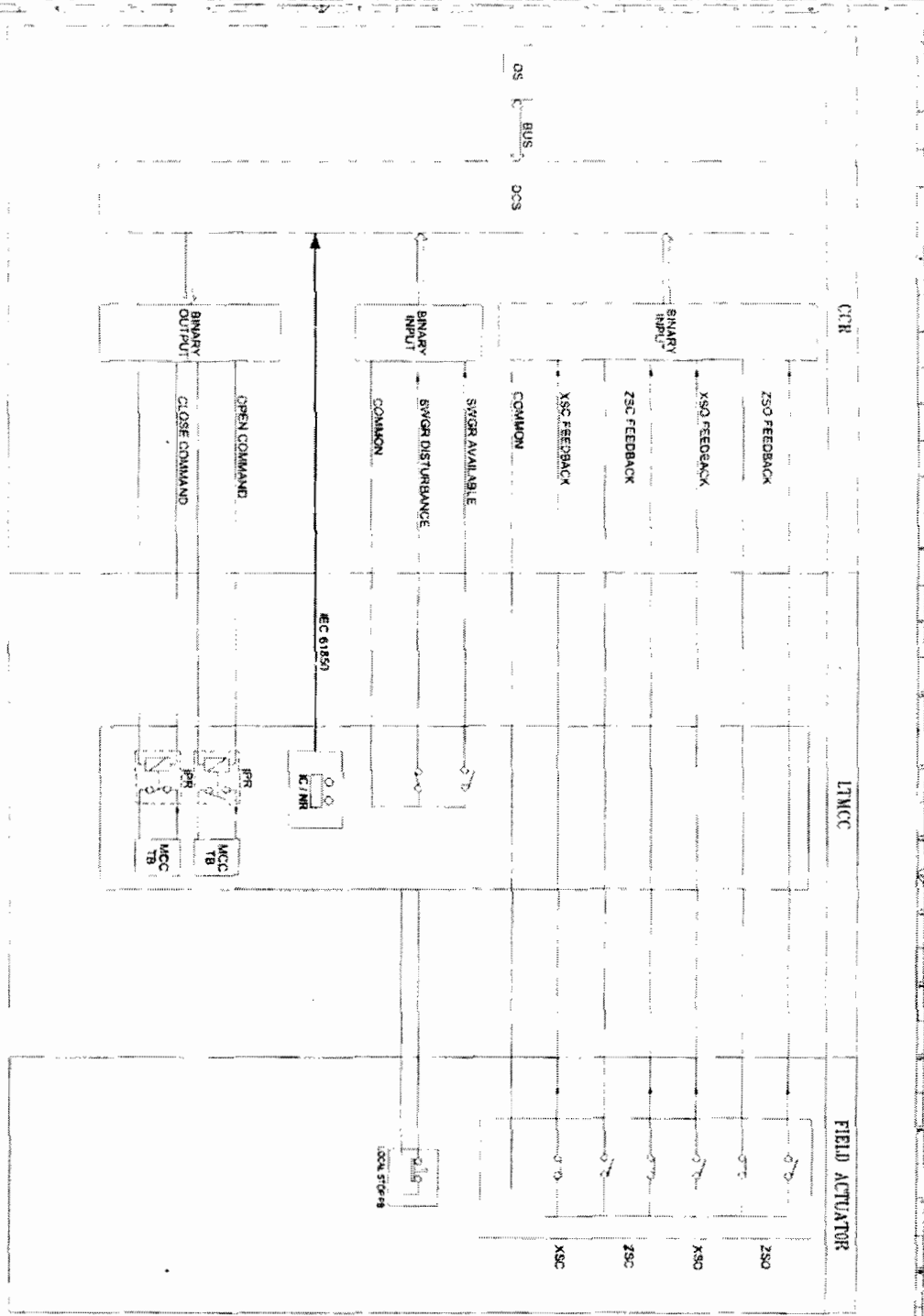

NOTE:
 1 FOR LIMIT SWITCH BOTH NO & NC CONTACT SHOULD BE WIRED
 2 TO DCS

- ABBREVIATIONS
- CCR - CENTRAL CONTROL ROOM
 - DCS - DISTRIBUTED CONTROL SYSTEM
 - MCC - MOTOR CONTROL CENTRE
 - SWGR - SWITCH GEAR
 - CR - OPERATOR STATION
 - IPR - INTERBAND RELAY
 - ZSO - LIMIT SWITCH OPEN
 - XSO - TORQUE SWITCH OPEN
 - ZSC - LIMIT SWITCH CLOSE
 - XSC - TORQUE SWITCH CLOSE
 - FB - PUSH BUTTON
 - IC - TERMINAL BLOCK
 - NC - INTERLOCK CONTROL RELAY
 - NR - NUMERICAL RELAY

FOR CONTRACT PURPOSE ONLY

104



NEVELL/LOMBE CORPORATION LTD, NEVELL TANK, MADURAI

2 X 500 HAN NEVELL S.A. ILL. 1164.
 POWER PRODUCT

LAMBER VIN INTERNATIONAL
 CONSULTING ENGINEERS, SURABAYA, INDONESIA

PRINT CONTROL PANEL DRAWING
 INSTRUMENTATION DIVISION
 NOVEMBER 1995

DATE: 18.07.08 15164-0017/72

NO. 13447
 05 1007

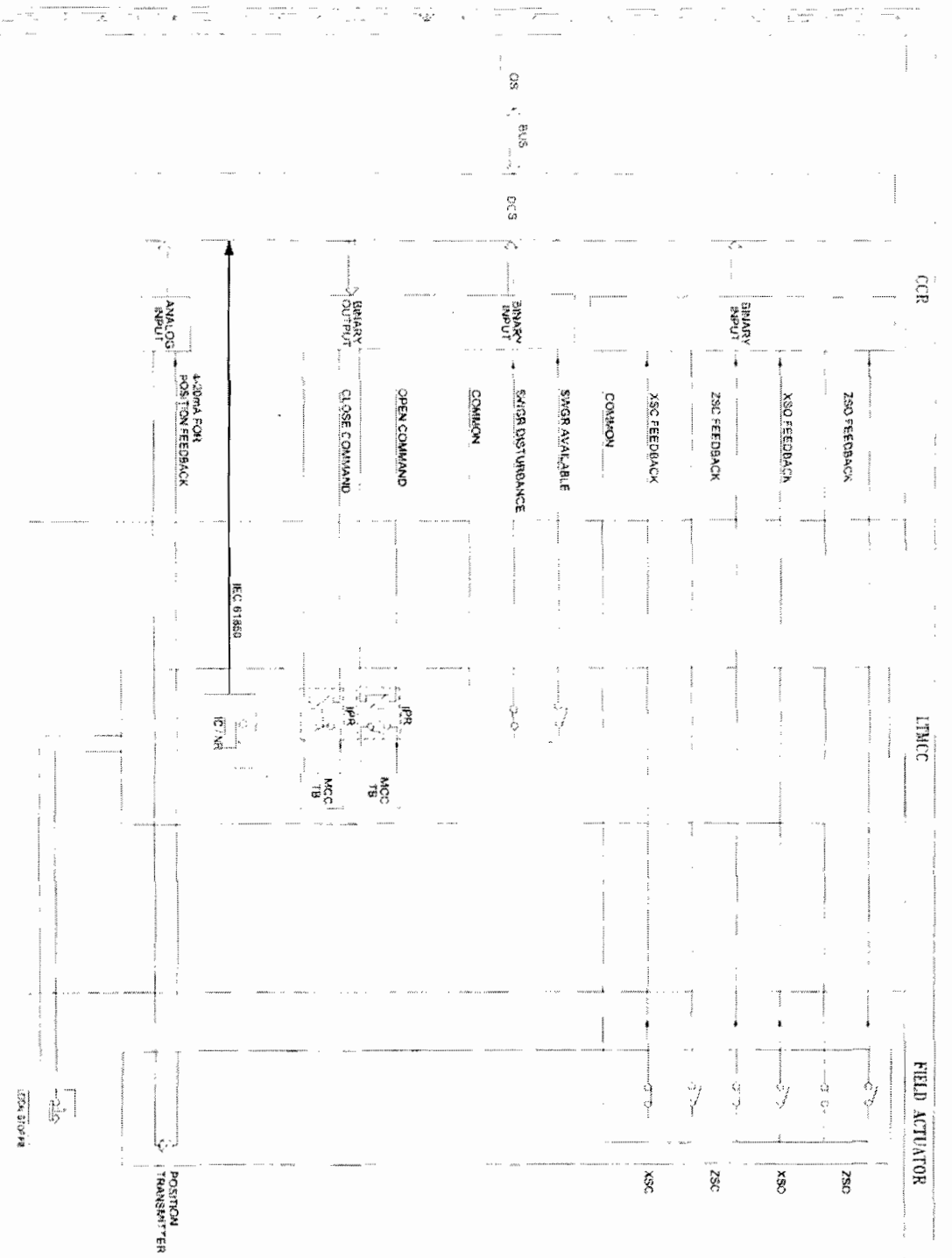

NOTE:
1 FOR LIMIT SWITCH BOTH NO & NC CONTACT SHOULD BE WIRED UP TO DCS.

ABBREVIATIONS

- CCR - CENTRAL CONTROL ROOM
- DCS - DISTRIBUTED CONTROL SYSTEM
- MCC - MOTOR CONTROL CENTRE
- SWGR - SWITCH-GEAR
- OP - OPERATOR STATION
- IPR - INTERLOCKING RELAY
- ZSO - LIMIT SWITCH-OPEN
- XSO - TORQUE SWITCH-OPEN
- ZSC - LIMIT SWITCH-CLOSE
- XSC - TORQUE SWITCH-CLOSE
- PS - PUSH-BUTTON
- TB - TERMINAL BOX
- IC - INTERLOCKED CONTROLLER
- NR - NUMERICAL RELAY

FOR CONTRACT PURPOSE ONLY

105

ai LAURENTECH INTERNATIONAL

LAURENTECH INTERNATIONAL LTD, NEWELL, TAMMINDY, COVENTRY, CV3 5EF, ENGLAND

3 X NON-REVERSIBLE COMPACTOR WITH 175-228

POWER PACKAGE

DESIGNED BY: LAURENTECH INTERNATIONAL LTD

CHECKED BY: LAURENTECH INTERNATIONAL LTD

DATE: 11/11/28

SCALE: 1:1

NO. 7-144

CD 17-28

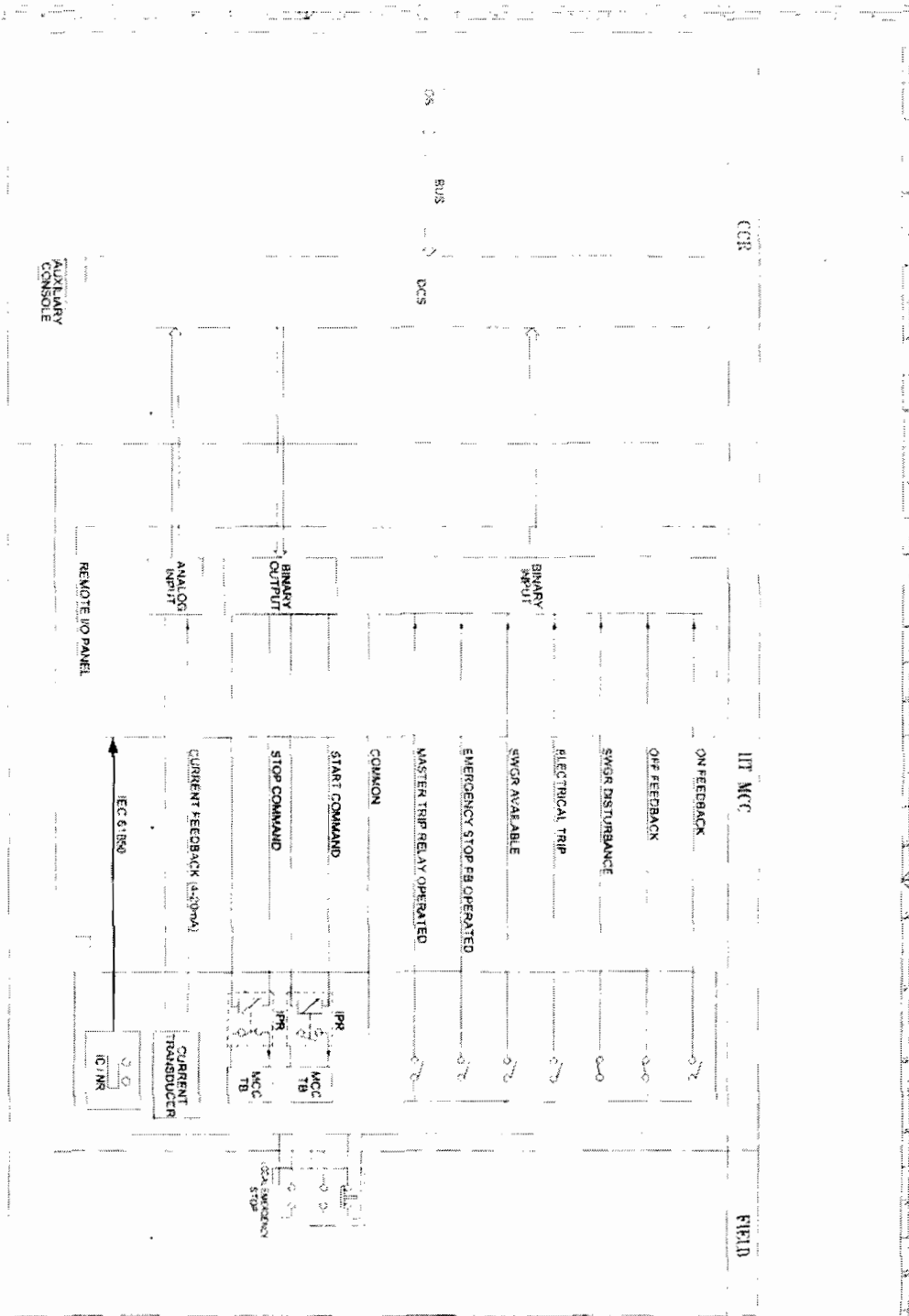

- ABBREVIATIONS**
- CCR - CENTRAL CONTROL ROOM
 - DCS - DISTRIBUTED CONTROL SYSTEM
 - MCC - MOTOR CONTROL CENTRE
 - SWGR - SWITCH GEAR
 - CS - OPERATOR STATION
 - IPR - INTERLOCKING RELAY
 - HO - INPUT/OUTPUT
 - TG - TERMINAL BOX
 - IC - INTELLIGENT CONTROLLER
 - NR - NUMERICAL RELAY

FOR CONTRACT PURPOSE ONLY



NEVELL ENGINEERING CORPORATION LTD. NEVELL TOWER

INTERVIEWER
 LAKSHMI INTERVIEWING AGENCY LTD
 CONSULTING ENGINEERS CORPORATION INDIA

PROJECT
 7 X 80 MW NEVELL NEW THERMAL
 POWER PROJECT
 GRID CONTROL AND DRIVE
 ENGINEERING DRAWING

DATE
 08/06/2010

SCALE
 1:100

NO.
 107

This scheme not required, plz check.

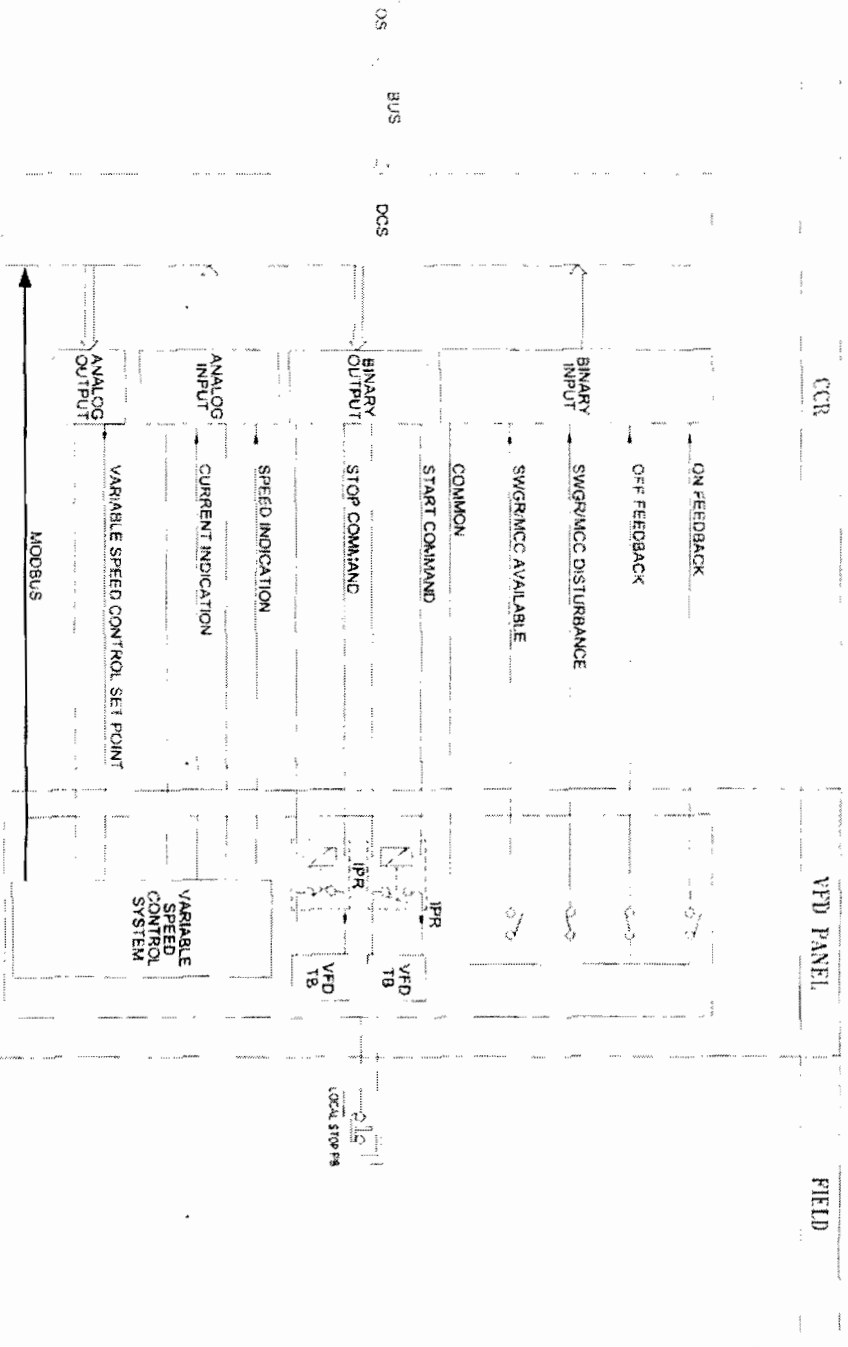

- ABBREVIATIONS
- CCR - CENTRAL CONTROL ROOM
 - DCS - DISTRIBUTED CONTROL SYSTEM
 - MCPC - MOTOR CONTROL CENTRE
 - OS - OPERATOR STATION
 - IPR - INTERPOSING RELAY
 - PB - PUSH BUTTON
 - SWGRMCC - SWITCH-GEAR
 - TB - TERMINAL BOX
 - VFD - VARIABLE FREQUENCY DRIVE

FOR CONTRACT PURPOSE ONLY



110

AMBER INTERATIONAL
 CHARTER INTERNATIONAL QUALITY LTD
 CONSULTING ENGINEERS COMPANY, INDIA
 2 x 800 VVA NEW VED NEW P-BEHALA
 POWER PROJECT

NEW DELHI CORPORATE OFFICE: NEW DELHI - 110001

PROJECT NO: 21001
 SHEET NO: 110
 DATE: 15-05-2017



Contractor quality assurance personnel for these shop and site tests shall be identified in advance and shall be acceptable to the Owner. The approval of the Owner/Consultant or passing of such inspection of tests shall not, however, prejudice the right of the Owner/consultant to reject the equipment if it does not comply with the specifications when erected or fails to give complete satisfaction in service.

2. The Contractor shall furnish details of shop and site tests proposed to be conducted by him at various stages to meet the specification requirements for each type of instrument/system along with his proposal. Contractor shall also furnish details of his proposed shop and site quality assurance organization for this contract.
3. Contractor shall prepare a detailed shop and site 'Quality Assurance Program' to meet the requirements of these specifications for Owner's/consultant's approval. This document shall also contain the formats for reports and maintenance of test records specification of test equipment to be used for site tests.
4. All equipment and systems furnished under this specification shall be subjected to shop & site tests in accordance with the Quality Assurance Program approved by the Owner/consultant and shall be adequate to ensure full compliance with these specification, all applicable codes & standards and detailed engineering drawings and documents approved by the Owner/consultant.
5. The Contractor shall provide all required test equipment and simulation devices for performing all shop and site tests. All tests equipment shall be of reputed make, required accuracy class and shall be recently calibrated. The record of calibration of test equipment shall be made available to the Owner/consultant on demand.

14.2.1 Test & Inspection for Instruments

After Manufacturing, all instruments shall be tested and calibrated at Factory. Contractor shall be responsible in obtaining test certificates related to calibration of all the Instruments and submit for Owner/Consultants approval. Contractor shall allow dispatch of these instruments only after passing applicable Factory Acceptance test and approved by Owner/consultant. The details of the tests to be carried out for the different instruments / field equipments/ Systems shall be as indicated in the Table-14.1 and any other tests as required by the Standards and Codes.

**Table 14.1
Test for Instruments**

S.N	Instruments/Equipments	Test to be conducted
1	Pressure indicators	<ul style="list-style-type: none"> • Calibration test • Hydro test (1.5 times max. Pr.)
2	Pressure switches	<ul style="list-style-type: none"> • Calibration test • Hydro test • Contact rating test





S.N	Instruments/Equipments	Test to be conducted
		<ul style="list-style-type: none"> • Accuracy test • Repeatability Test • Hysteresis test • Differential test
3	Pressure Transmitters	<ul style="list-style-type: none"> • Calibration test • Hydro test • Leak test • Over range test • Accuracy test • Repeatability test.
4	Differential Pressure Indicators	<ul style="list-style-type: none"> • Calibration test • Hydro test • Leak test • Over range test • Accuracy test • Repeatability test.
5	Differential Pressure Switches	<ul style="list-style-type: none"> • Calibration test • Hydro test • Leak test • Over range test • Accuracy test • Repeatability test
6	Differential Pressure Transmitters	<ul style="list-style-type: none"> • Calibration test • Hydro test • Leak test • Over range test • Accuracy test • Repeatability test.
7	Thermometers	<ul style="list-style-type: none"> • Calibration test • Material test • Accuracy test • Bore concentricity • Hydrostatic test for TW (1.5 times max. pr.).
8	Temperature switch	<ul style="list-style-type: none"> • Calibration test • Material test • Accuracy test • Bore concentricity • Hydrostatic test for TW (1.5 times max.pr.) • Contact rating test
9	Resistance temperature detector assembly	<ul style="list-style-type: none"> • Calibration • Material test • Accuracy test • Bore concentricity test • Insulation test (< 500 M ohms at 500 V, DC) as per ISA • Hydro test for TW. • Accuracy test
10	Thermocouple assembly	<ul style="list-style-type: none"> • Calibration • Material test • Insulation test (< 500 at 500 V, DC) as per ISA • Hydro static test (1.5 times max. pr.)

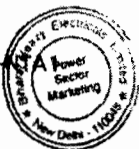



S.N	Instruments/Equipments	Test to be conducted
		<ul style="list-style-type: none"> Bore concentricity Accuracy test
11	Temperature transmitters	<ul style="list-style-type: none"> Calibration test Accuracy test Ambient temperature error test
12	Thermowells	<ul style="list-style-type: none"> Material test Bore concentricity : $\pm 1.5\%$ of wall thick Hydrostatic test for TW (1.5 times max.pr)
13	Interposing relay	<ul style="list-style-type: none"> Functional test Temperature rise test High voltage test Limits of operation test Insulation test Contact rating test
14	Level gauges	<ul style="list-style-type: none"> Hydrostatic test Material test Seat leakage test Ball check test
15	Level switches	<ul style="list-style-type: none"> Material test Contact rating test Hydro test Calibration test
16	Level Switch (Probe)	<ul style="list-style-type: none"> Material test Contact rating test Hydro test Calibration test
17	Flow switch	<ul style="list-style-type: none"> Material test Hydro test (1.5 time max. pr) Functional test
18	Flow glasses	<ul style="list-style-type: none"> Material test Hydro test (1.5 time max. pr) Functional test
19	Variable area flow metes	<ul style="list-style-type: none"> Calibration test Material test Hydrostatic test (1.5 time max.pr)
20	Flow element	<ul style="list-style-type: none"> 100% Radiography test Hydro test / Calibration test IBR certificate
21	Control valves	<ul style="list-style-type: none"> IBR certificate Form III C Hydrostatic test : IBR/MSS-SP-61/ANSI B 16.34 Seat leakage test : As per ANSI B 16-104 CV test : As per ISA procedure Magnetic particle test : As per ANSI B 16.34 Special class (applicable for pr. > 70 bar & tem < 4000C Liquid penetration test : As per ANSI B 16.34 Special class (applicable for pr > 70 bar & temp < 4000C Calibration Hysteresis test
22	Position Transmitters	<ul style="list-style-type: none"> Calibration

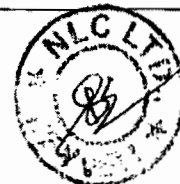
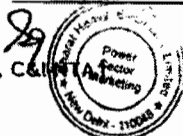



S.N	Instruments/Equipments	Test to be conducted
		<ul style="list-style-type: none"> • Hysteresis • Accuracy test
23	I/P Converters	<ul style="list-style-type: none"> • Calibration test • Accuracy Test
24	Solenoid Valves	<ul style="list-style-type: none"> • Hydro test • Seat leakage test • CV test • Coil insulation test
25	Air Filter Regulators	<ul style="list-style-type: none"> • Calibration test • Accuracy test
26	Junction Boxes	<ul style="list-style-type: none"> • Test for degree of protection • Material test
27	Transmitter Racks/ Enclosures/Local Panels/Marshalling Cabinets/System Cabinet	<ul style="list-style-type: none"> • Hydro test • Air leak test for tubing, Piping & fittings Verification of degree of protection • Test for enclosure type • Type tests & routine tests as per relevant Indian standards. • Electrical tests as detailed under "Wiring, Terminations & Accessories"
28	Wiring Termination and Accessories	
a	Routine test	<ul style="list-style-type: none"> • Conductor resistance test (*) • High voltage test (*) • Impulse dielectric test • Insulation test • Humidity test • Temperature rise tests on power circuits • Short time current tests on power circuits.
b	Type test	<ul style="list-style-type: none"> • Annealing test (*) • Test for insulation and sheath (*) • Flame retardance test - (a) Oxygen index, (b) Flammability • Test for acid gas generation • Test for water absorption (*) • Wet dielectric test.
		Note (*) - As per IS-1554
29	Test for terminal blocks	<ul style="list-style-type: none"> • Test for moulding for flame resistant • Non-hygroscopic and Decarbonised • Insulation test between terminals • Insulation between terminal block and frame

14.2.2 Test & Inspection for SG Integral Control system

Tests for SG integral control system shall include:-

1. Factory Acceptance Test (FAT):





2x500 MW, NNTPP, Neyveli
CONTRACT SPECIFICATION
STEAM GENERATOR & AUX. PACKAGE - NTA1



- There has been no change in the components from the offered equipment & tested equipment.
- The test has been carried out as per the latest standards along with amendments as on the date of contract signing.

In case the approved equipment is different from the one on which the type test had been conducted earlier on any of the above grounds, then the tests have to be repeated and the cost of such tests shall be borne by the Contractor within the quoted price and no extra cost shall be payable by the Owner on this account

4. As mentioned against certain items, the test certificates for some of the items shall be reviewed and approved by the Contractor or his authorized representative and the balance have to be approved by the Owner/consultant.
5. The schedule of conduction of type tests/ submission of reports shall be submitted and finalized during detail engineering.
6. For the type tests to be conducted, Contractor shall submit detailed test procedure for approval by Owner/consultant. This shall clearly specify test setup, instruments to be used, procedure, acceptance norms (wherever applicable), recording of different parameters, interval of recording precautions to be taken etc. for the tests to be carried out.
7. All applicable requirements of latest revised edition of I.S.A. Recommended practice MC-55.1 - 1982/ANSI MC 8.1-1975 regarding hardware testing of Digital process computers shall be fully met.

Table 14.2

Type Test Requirement

S. N	Item	Test Requirement	Standard	Test To Be Specifically Conducted	Approval Req. on Test Certificate	Remarks
1	Transducers	As per standard	IEC-688, IS12784	No	Yes	
2	Thermocouple	Degree of protection test	IS-1247	No	No	
3	RTD	As per standard	IEC-751	No	No	
4	Electronic transmitter	As per standard	BS-6447 / IEC-770	No	Yes	
5	E/P converter	As per standard	Mfr. Standard	No	No	
6	Pressure gauge	Degree of Protection test Temp interference	IS-2147 IS-3624	No No	No No	





S. N	Item	Test Requirement	Standard	Test To Be Specifically Conducted	Approval Req. on Test Certificate	Remarks
		test				
7	Temperature gauge	Degree of protection test	IS-2147	No	No	
8	Pressure & DP switch	Degree of Protection test As per standard	IS-2147 BS 6134	No No	No No	
9	Level switch	Degree of protection test	IS-2147	No	No	
10	Conductivity level switch	Degree of protection test	IS-2147	No	No	
11	Control valves	CV Test	ISA 75.02	Yes	No	
12	Flow Nozzles & Orifice plate	Calibration	ASME PTC BS1042	Yes	No	
13	SG control System a) I/O modules b) Other modules c) CLCS Systems	SIL-3(for Boiler Protection System) CMRR & NMRR verification CMRR & NMRR Verification Model test	As per standard Mfr standard Mfr standard Approved procedure	Yes Yes Yes Yes	Yes Yes Yes Yes	
14	LIE / LIR / Junction Box	Degree of protection test	IS-2147	No	No	
15	Flue gas O2	Degree of protection test	IS-2147	No	Yes	





2x500 MW. NNTPP, Neyveli
CONTRACT SPECIFICATION
STEAM GENERATOR & AUX. PACKAGE - NTA1



S. N	Item	Test Requirement	Standard	Test To Be Specifically Conducted	Approval Req. on Test Certificate	Remarks
	Analys er					
16	Flue gas CO Analyser	Degree of protection test	IS-2147	No	Yes	





STANDARD QUALITY PLAN FOR PRESS AND DIFF PRESS SWITCHES

QUALITY PLAN NO.: PE-QP-999-145-1031

VOLUME IIB

SECTION D

REV. NO. 01 DATE: 16.05.2007

SHEET 1 OF 3

PEM :: C&I

Sl. No.	Component / operation	Characteristics Checked	* Category	Type/Method of Check	Extent of Check	Reference documents	Acceptance Norms	Format of Records	Agency \$			Remarks
									P	W	V	
1.0	Raw Material/Component Sensing Element, Casing, Contact, Process Connection	1. Chem. Composition	MA	Chemical Analysis	1 sample from each lot	BHEL Spec. / Approved data sheet	Relevant material standard	Test Report	3/2	--	2,1	Relevant compliance certificate to be verified.
		2. Make, Marking, Damage and Cracks	MA	Visual	100%	BHEL spec. / manufacturer standard	BHEL spec. / manufacturer standard	Log Book	2	--	--	
		3. Leakage (Element Conn.)	MA	Pressure Test	100%	Manufacturer standard	No Leak	Log Book	2	--	--	
2.0	Final Inspection	1. No. and type of contacts	MA	Visual	100%	BHEL Spec. / Approved data sheet	BHEL Spec. / Approved data sheet	Log Book	3/2	--	2,1	
		2. Continuity	CR	Electrical	100%	Manufacturer standard	To have continuity	Log Book	3/2	--	2,1	
2.1	Assembly	1. Marking: Range, Model, Tag No. Sl.No.	MA	Visual	100%	BHEL Spec. / Approved data sheet	BHEL Spec. / Approved data sheet	Inspection Report	2	1	--	10% to be witnessed by BHEL
		2. Correct assembly, workmanship and finish	MA	Visual	100%	Manufacturer standard	Manufacturer standard	Log Book	2	1	--	- do -

LEGEND: * CR - Critical characteristics
 MA - Major characteristics
 MI - Minor characteristics

\$ P - Agency Performing the Test.
 W - Agency Witnessing the Test.
 V - Agency Verifying the Test.

1 - BHEL
 2 - Vendor
 3 - Sub-vendor

Sl. No.		Component / operation	Characteristics Checked	* Category	Type/Method of Check	Extent of Check	Reference documents	Acceptance Norms	Format of Records	Agency \$			Remarks
										P	W	V	
STANDARD QUALITY PLAN FOR PRESS AND DIFF PRESS SWITCHES													
QUALITY PLAN NO.: PE-QP-999-145-1031 VOLUME IIB SECTION D REV. NO. 01 DATE: 16.05.2007 SHEET 2 OF 3													
2.2	Routine Test	3. Connection	MA	Visual & Measurement	100%	BHEL Spec. / Approved data sheet	BHEL Spec. / Approved data sheet	Inspection Report	2	1	---	10% to be witnessed by BHEL	
		4. Scale Marking	MA	Visual	100%	BHEL Spec. / Approved data sheet	BHEL Spec. / Approved data sheet	Inspection Report	2	1	---	- do -	
		5. Cleanliness	MA	Visual	100%	Manufacturer standard	Free from scratches dirt etc.	Log Book	2	1	---	- do -	
		6. Overall Dimension	MA	Measurement	100%	BHEL Spec. / Approved data sheet	BHEL Spec. / Approved data sheet	Inspection Report	2	1	---	- do -	
		1. Overload	CR	Measurement	100%	BHEL Spec. / Approved data sheet	BHEL Spec. / Approved data sheet	Test Report	2	1	1	- do -	
		2. Repeatability	CR	Measurement	100%	BHEL Spec. / Approved data sheet	BHEL Spec. / Approved data sheet	Test Report	2	1	1	- do -	
		3. Set point adjustment	CR	Measurement	100%	BHEL Spec. / Approved data sheet	BHEL Spec. / Approved data sheet	Test Report	2	1	1	- do -	
		4. Differential	CR	Measurement	100%	BHEL Spec. / Approved data sheet	BHEL Spec. / Approved data sheet	Test Report	2	1	1	- do -	

LEGEND: * CR - Critical characteristics
 MA - Major characteristics
 MI - Minor characteristics
 \$ P - Agency Performing the Test.
 W - Agency Witnessing the Test.
 V - Agency Verifying the Test.
 1 - BHEL
 2 - Vendor
 3 - Sub-vendor



STANDARD QUALITY PLAN FOR PRESS AND DIFF PRESS SWITCHES

QUALITY PLAN NO.: **PE-QP-999-145-1031**
 VOLUME **IIB**
 SECTION **D**
 REV. NO. **01** DATE: **16.05.2007**
 SHEET **3** OF **3**

Sl. No.	Component / operation	Characteristics Checked	* Category	Type/Method of Check	Extent of Check	Reference documents	Acceptance Norms	Format of Records			Remarks
								P	W	V	
2.3	Type Test	5. Contact Rating	CR	Measurement	100%	BHEL Spec. / Approved data sheet	BHEL Spec. / Approved data sheet	2	---	1	Manufacturer compliance certificate to be verified. 10% to be witnessed by BHEL - do -
		6. Insulation Resistance & HV	CR	Electrical	100%	Relevant standard	Relevant standard	2	1	1	
		7. Calibration Test	CR	Measurement	100%	BHEL Spec. / Approved data sheet	BHEL Spec. / Approved data sheet	2	1	1	
		8. Accuracy Test	CR	Measurement	100%	BHEL Spec. / Approved data sheet	BHEL Spec. / Approved data sheet	2	1	1	
3.0	Packing	1. Weatherproofness	CR	Measurement	1 sample / design	BHEL Spec. / Approved data sheet	BHEL Spec. / Approved data sheet	3/2	---	1	Vendor to furnish test report for verification
		Soundness of packing	MA	Visual	100%	BHEL Spec.	BHEL Spec.	3/2	2	---	

LEGEND: * CR - Critical characteristics
 MA - Major characteristics
 MI - Minor characteristics

* P - Agency Performing the Test.
 W - Agency Witnessing the Test.
 V - Agency Verifying the Test.

1 - BHEL
 2 - Vendor
 3 - Sub-vendor

FORM NO. PEM-6995-0

	CHECK LIST FOR PRESSURE / DIFFERENTIAL PRESSURE TRANSMITTER (Mechanical Auxilliary Packages)	SPECIFICATION NO.:	
		VOLUME	
		SECTION	
		REV. NO.	DATE:
		SHEET OF	
Data Sheet No.: PE-CL-999-145-1026-0			

SL NO	TESTS/CHECKS	QUANTM OF CHECK	REFERENCE DOC. ACCEPTANCE NORMS	AGENCY			REMARKS
				M	C	B	
1.0	CHECKS FOR VISUAL, MODEL TAG NO.	SEE NOTE-1 BELOW	APPROVED TECHNICAL REQUIREMENT/ DATA SHEET	P	W	V	MFR TO CARRY OUT ROUTINE TEST ON 100%. WHEN MATERIAL CORELATION ARE NOT AVAILABLE MFR'S COMPLIANCE TO BE PROVIDED
2.0	PROCESS CONNECTION	-do-		P	W	V	
3.0	ACCURACY	-do-		P	W	V	
4.0	REPEATEABILITY	-do-		P	W	V	
5.0	HYSTERISIS	-do-		P	W	V	
6.0	EFFECT OF TEMP VARIATION ON ACCURACY	-do-		P	W	V	
7.0	SPAN /ZERO ADJUSTMENT	ONE/TYPE		P	W	V	
8.0	EFFECT OF SUPPLY VOLTAGE VARIATION	ONE/TYPE		P	W	V	
9.0	HIGH PRESSURE TEST	SEE NOTE-1 BELOW		P	W	V	
10.0	BURN IN TEST	ONE/TYPE		P	W	V	
11.0	DEGREE OF PROTECTION	ONE/TYPE		P	W	V	

LEGEND:
M: MANUFACTURER/ SUB CONTRACTOR, C: CONTRACTOR/ NOMINATED INSP AGENCY, B: BHEL. P: PERFORM, W: WITNESS, V: VERIFICATION.

- NOTE:**
1. QUANTUM OF CHECK SHALL BE AS BELOW
100 % - BY MANUFACTURER
RANDOM FOR EACH TYPE - BY BHEL & CUSTOMER
 2. MANUFACTURER TO MAINTAIN CALIBRATED INSTRUMENT HAVING BETTER ACCURACY THAN THE ITEM UNDER TEST. INSPECTING ENGINEER SHALL CHECK THE SAME.
 3. IN CASE OF IMPORTED ITEMS CONTRACTORS SHALL REVIEW TC's AND NOT INSPECT.

CONTRACTOR TO PROVIDE COMPLIANCE CERTIFICATE FOR TESTS/CHECKS VERIFIED BY CONTRACTOR AND SUBMIT THE SAME ALONGWITH TEST CERTIFICATES TO BE VERIFIED BY BHEL.

	CHECK LIST FOR PRESSURE / DIFFERENTIAL PRESSURE GAUGE (MECHANICAL AUXILIARY PACKAGES)	SPECIFICATION NO.: PE-TS-394-145-I054	
		VOLUME	
		SECTION	
		REV. NO. 00	DATE: 27.09.2013
		SHEET 13	OF 19

SL NO	TESTS/CHECKS	QUANTM OF CHECK	REFERENCE DOC. ACCEPTANCE NORMS	AGENCY			REMARKS
				P	W	V	
1.0	CHECK FOR		APPROVED TECHNICAL REQUIREMENT/ DATA SHEET				MFR TO CARRY OUT ROUTINE TEST ON 100%. WHEN MATL CORELATION ARE NOT AVAILABLE MFR'S COMPLIANCE TO BE PROVIDED
	1.1 DIAL SIZE	100%		M	C	C	
	1.2 MODEL NO/TAG NO	100%		M	C	C	
	1.3 RANGE/SCALE	100%		M	C	C	
	1.4 END CONNECTION	100%		M	C	C	
	1.5 SWITCH CONTACT RATING & NOS	100%		M	C	C	
2.0	CALIBRATION						
	2.1 ACCURACY	100%		M	C	B	
	2.2 REPEATABILITY (FOR SWITCH)	100%		M	C	B	
	2.3 SET POINT ADJUSTMENT FOR SWITCH	100%		M	C	C	
3.0	OVER PRESSURE & LEAK TEST	100%		M	C	C	
4.0	OPERATION OF PR. RELEIF DEVICE	ONE PER TYPE		M	C	C	
5.0	REVIEW OF T.C. FOR MATERIAL OF--						
	5.1 SENSOR	FOR LOT		-	-	B	
	5.2 MOVEMENT			-	-	B	
	5.3 PROCESS CONNECTION		-	-	B		
	5.4 HOUSING		-	-	B		
6.0	REVIEW OF T.C. FOR DEGREE OF PROTECTION	TYPE TEST	-	-	B		
7.0	REVIEW OF T.C. FOR CONTACT RATING OF SWITCH	ONE PER TYPE	-	-	B		
8.0	ACCESSORIES AS APPLICABLE	100%	M	C	C		

LEGEND:

M: MANUFACTURER/ SUB CONTRACTOR, C: CONTRACTOR/ NOMINATED INSP AGENCY, B: BHEL. P: PERFORM, W: WITNESS, V: VERIFICATION.

NOTE:

CONTRACTOR TO PROVIDE COMPLIANCE CERTIFICATE FOR TESTS/CHECKS VERIFIED BY CONTRACTOR AND SUBMIT THE SAME ALONGWITH TEST CERTIFICATES TO BE VERIFIED BY BHEL.



STANDARD QUALITY PLAN FOR TEMPERATURE GAUGE AND THERMOWELL

QUALITY PLAN NO.: PE-QP-999-145-1027

VOLUME IIB

SECTION D

REV. NO. 01 DATE: 16-05-2007

SHEET 1 OF 4

Sl. No.	Component / operation	Characteristics Checked	* Category	Type/Method of Check	Extent of Check	Reference documents	Acceptance Norms	Format of Records			Remarks	
								P	W	V		
1.0	Raw Material / Component											
1.1	Capillary Bulb and Thermowell	1. Chemical composition 2. Marking. 3. Dimensions	CR MA MA	Chemical analysis Visual Measurement	one sample/lot 100% 100%	BHEL spec. / approved data sheet BHEL spec. / Mfr. Standard BHEL spec. / approved doc	Relevant raw material std. BHEL spec. / Mfr. Standard BHEL spec. / approved doc	Test report Log Book Log Book	3/2 2 2	--- --- ---	2,1 --- ---	Relevant compliance certificate to be verified by BHEL
1.2	Casing and Bezel	1. Material 2. Defects 3. Dimension 4. Threading	MA MA MA MA	Chemical analysis Visual Measurement Thread matching	Sample 100% Sample 100%	BHEL spec. Mfr. Standard BHEL spec. / approved doc. ---do---	BHEL spec. Mfr. Standard BHEL spec. Mfr. Standard	Test report Log Book Log Book Log Book	3/2 2 2 2	--- --- --- ---	2,1 --- --- ---	Relevant compliance certificate to be verified by BHEL
1.3	Dial	1. Size, range, scale length, least-count, spacing and graduation. 2. Colour 3. Resistance to dry heat and hot water	MA MA MA	Measurement and Visual Visual Oven & Bath	Sample 100% Sample	BHEL spec. BHEL spec. Mfr. Standard	BHEL spec. BHEL spec. Mfr. Standard	Log Book Log Book Test report	2 2 3/2	--- --- ---	--- --- ---	

LEGEND: * CR - Critical characteristics
 MA - Major characteristics
 MI - Minor characteristics

‡ P - Agency Performing the Test.
 W - Agency Witnessing the Test.
 V - Agency Verifying the Test.

1 - BHEL
 2 - Vendor
 3 - Sub-vendor

42

QUALITY PLAN NO.: PE-QP-999-145-1027

VOLUME IIB
SECTION D
REV. NO. 01 DATE: 16-05-2007
SHEET 2 OF 4

**STANDARD QUALITY PLAN
FOR
TEMPERATURE GAUGE AND THERMOWELL**



Sl. No.	Component / operation	Characteristics Checked	* Category	Type/Method of Check	Extent of Check	Reference documents	Acceptance Norms	Format of Records			Agency \$			Remarks
								P	W	V	P	W	V	
1.4	Complete sensing element	1. Correct assembly and workmanship.	MA	Visual	100%	Mfr. Standard drawing	Mfr. Standard drawing	Log Book	2	---	---	---	---	
		2. Dimensions	MA	Measurement	100%	Mfr. Standard drawing	Mfr. Standard drawing	Log Book	2	---	---	---	---	
		3. Welding & other defects	MA	Visual	100%	Mfr. Standard	Mfr. Standard	Log Book	2	---	---	---	---	
1.5	Thermowell ⊕	1. Dimensions of wall thickness, concentricity of bore OD & Length.	MA	Measurement	100%	BHEL spec. / approved data sheet / Drg.	BHEL spec. / approved data sheet / Drg.	Log Book	2	1	1	1	1	BHEL to witness 10 % random samples.
		2. Leak Test	CR	Hyd. test at 1.5 times of design pressure.	100%	BHEL spec. / approved data sheet / Drg.	BHEL spec. / approved data sheet / Drg.	Inspection report	3/2	2,1	1	1	1	⊕ IBR cert. wherever specified to be verified.
		3. Threading	MA	Thread matching	100%	BHEL spec. / approved data sheet / Drg	BHEL spec. / approved data sheet / Drg	Inspection report	2	2,1	1	1	1	BHEL to witness 10% samples.
2.0	Final Inspection													
2.1	Assembly	1. Correct assembly, workmanship and finish	MA	Visual	100%	BHEL spec. / approved data sheet	BHEL spec. / approved data sheet	Inspection report	2	1	---	---	---	

LEGEND: * CR - Critical characteristics
 MA - Major characteristics
 MI - Minor characteristics

\$ P - Agency Performing the Test.
 W - Agency Witnessing the Test.
 V - Agency Verifying the Test.

1 - BHEL
 2 - Vendor
 3 - Sub-vendor



STANDARD QUALITY PLAN FOR TEMPERATURE GAUGE AND THERMOWELL

QUALITY PLAN NO.: PE-QP-999-145-1027

VOLUME IIB

SECTION D

REV. NO. 01 DATE: 16-05-2007

SHEET 3 OF 4

Sl. No.	Component / operation	Characteristics Checked	* Category	Type/Method of Check	Extent of Check	Reference documents	Acceptance Norms	Format of Records	Agency \$			Remarks
									P	W	V	
		2. Mounting and connection	MA	Visual ad measurement	100%	-----do-----	-----do-----	Inspection report	2	1	---	
		3. Dial Scale	MA	Visual	100%	-----do-----	-----do-----	Log Book	2	1	---	
		1. Cleanliness	MA	Visual	100%	-----do-----	Free from scratches, dirt etc.	Log Book	2	---	2	
		5. Marking (S.No., Tag No.)	MA	Visual	100%	BHEL spec. / approved data sheet	BHEL spec. / approved data sheet	Log Book	2	1	---	
2.2	Routine Test	1. Accuracy	MA	Measurement	100%	BHEL spec. / Approved data Sheet.	BHEL spec. / Approved data Sheet.	Test Report	2	1	1	BHEL to witness 10% random Samples.
		2. Overload	CR	Measurement	10%	125% of FSD for range upto 400 Deg. C. 110% of FSD for range between 400 to 500 Deg. C. 100% of FSD for range above 500 Deg. C.	No Damage	Test Report	2	1	---	

LEGEND: * CR - Critical characteristics
MA - Major characteristics
MI - Minor characteristics

\$ P - Agency Performing the Test.
W - Agency Witnessing the Test.
V - Agency Verifying the Test.

1 - BHEL
2 - Vendor
3 - Sub-vendor

QUALITY PLAN NO.: PE-QP-999-145-1027
 VOLUME IIB
 SECTION D
 REV. NO. 01 DATE: 16-05-2007
 SHEET 4 OF 4

**STANDARD QUALITY PLAN
 FOR
 TEMPERATURE GAUGE AND THERMOWELL**



Sl. No.	Component / operation	Characteristics Checked	* Category	Type/Method of Check	Extent of Check	Reference documents	Acceptance Norms	Format of Records	Agency †			Remarks
									P	W	V	
		3. Response Time	MA	Measurement	10%	ASME PTC19.3	ASME PTC19.3	Test Report	2	1	1	BHEL to witness 10% random samples.
2.3	Type Test	1. Ambient temperature compensation 0-60 Deg. C	MA	Measurement	Sample	Bulb at constant temp. & case temp varied 0-60 Deg. C	No variation in measurement	Test Certificate	2	---	1	Existing test certificate (Not more than 5 year old) shall be furnished.
		2. Weather proofness	CR	Measurement	Sample	BHEL spec. / Approved data sheet.	BHEL spec. / Approved data sheet.	Test Certificate	3/2	---	1	---do---
3.0	Packing	Soundness of packing	MA	Visual	100%	BHEL Spec.	BHEL Spec.	Log Book	3/2	2	---	Refer Note-1

Note: 1. In the absence of BHEL specification for painting, vendor to obtain BHEL's approval on their painting specification / procedure.

LEGEND: * CR - Critical characteristics
 MA - Major characteristics
 MI - Minor characteristics

† P - Agency Performing the Test.
 W - Agency Witnessing the Test.
 V - Agency Verifying the Test.

1 - BHEL
 2 - Vendor
 3 - Sub-vendor

**STANDARD QUALITY PLAN
 FOR
 SIGHT FLOW INDICATOR**



PEM :: C&I

Sl. No.	Component / operation	Characteristics Checked	* Category	Type/Method of Check	Extent of Check	Reference documents	Acceptance Norms	Form of Records	Agency \$			Remarks
									P	W	V	
1.0	Material / Components											
1.1	Body, Cover, Interns, Flanges, Gaskets	1. Physical, Chemical Properties 2. Workmanship, finish and dimensions	MA	Physical, Chemical Test	One Sample from each lot	Approved drg. / data sheet / BHEL Spec.	Approved drg. / data sheet / BHEL Spec.	Test Certificate	3/2	---	2,1#	# Compliance certificate to be verified.
1.2	Window Glass	Strength, Transparency, dimensions	MA	Visual, Measurement	100%	Manufacturing standards / drgs.	Manufacturing standards / drgs.	Inspection Report / Log Book	3/2	---	2,1#	
2.0	Assembly	1. Marking -- Tag No., Model, Range 2. Workmanship 3. Direction of flow stamping 4. Dimensions and end connections	MA	Toughness & Thermal shock, Visual, Measurement	one sample from each lot	Approved drg. / data sheet / BHEL Spec.	Approved drg. / data sheet / BHEL Spec.	Test Certificate/ Inspection Report	3	---	2,1#	
3.0	Routine Test	1. Operation, Calibration⊕ 2. Hydro Test	CR	Measurement	100%	- do -	- do -	Inspection Report	2	1	---	⊕ For flapper type
									2	1**	1	**10% quantity with minimum of 1 piece / type & size

LEGEND: * CR - Critical characteristics
 MA - Major characteristics
 MI - Minor characteristics

\$ P - Agency Performing the Test.
 W - Agency Witnessing the Test.
 V - Agency Verifying the Test.

1 - BHEL
 2 - Vendor
 3 - Sub-vendor

QUALITY PLAN NO.: PE-QP-999-145-1029
 VOLUME IIB
 SECTION D
 REV. NO. 00 DATE: 08.11.2000
 SHEET 2 OF 2

**STANDARD QUALITY PLAN
 FOR
 SIGHT FLOW INDICATOR**



Sl. No.	Component / operation	Characteristics Checked	* Category	Type/Method of Check	Extent of Check	Reference documents	Acceptance Norms	Format of Records	Agency *			Remarks
									P	W	V	
4.0	Painting	Shade & Finish	MA	Visual	100%	Approved drg. / data sheet / BHEL Spec.	Approved drg. / data sheet / BHEL Spec.	Inspection Report	2	1**	1	
5.0	Packing	Soundness	MA	Visual	100%	- do -	- do -	- do -	2	---	---	

LEGEND: * CR - Critical characteristics
 MA - Major characteristics
 MI - Minor characteristics

1 - BHEL
 2 - Vendor
 3 - Sub-vendor

§ P - Agency Performing the Test.
 W - Agency Witnessing the Test.
 V - Agency Verifying the Test.



**TECHNICAL SPECIFICATION FOR
COMPRESSED AIR SYSTEM
2 X 500 MW NNTPS, NEYVELI**

SPEC NO. PE-TS-400-555-A001

VOLUME-IIB

SECTION C.5

REV.NO. 0

**VOLUME - II B
SECTION C.5**

PERFORMANCE AND DEMONSTRATION GUARANTEE



microns will be provided. Total DFT of paint system will not be less than 200 microns.

- e) For all the steel surfaces inside the building (indoor installation), a coat of red oxide primer of minimum thickness of 50 microns followed up with undercoat of synthetic enamel paint of minimum thickness of 50 microns will be applied. The top coat will consist of two coats each of minimum thickness of 50 microns of synthetic enamel paint and thus total thickness will be minimum 200 microns.
- f) Also refer the Section-XI for painting system.

8.6 Inspection & Testing

1. The Contractor will carry out the following specific tests and inspections to ensure that the equipment furnished will conform to the requirements of this section and in accordance with relevant codes and standards.
2. Material identification of compression chambers, rotor, rotor staff, suction and delivery valves constituting the compressors and all parts of intercoolers, aftercoolers, moisture separators, air receivers, strainers, filters, all interconnecting air and water piping with valves and all other parts and accessories that could not spelt out in this clause.
3. Hydrostatic testing of compressor, intercoolers, aftercoolers, moisture separators, air receivers, strainers, filters, all interconnecting air and water piping with valves and all other applicable pressure parts that could not be spelt out in this clause will be carried out. Hydrostatic testing will be carried out at 150% of the design pressure for at least one (1) hour, unless contradicted by the relevant test code.
4. Specific tests to be carried out for each compressor
5. Non-destructive testing of rotors, rotor shaft and all other applicable parts.
6. Type test/Routine tests for all the air compressors as per ISO-1217. All performance tests for compressors will be carried out with actual motor being furnished. Routine tests will include the following tests and measurements:
 - a) Capacity (Free Air delivery)
 - b) Speed
 - c) Specific power consumption
 - d) Volumetric and overall efficiency of machine
 - e) Test of loading and unloading mechanism
 - f) Any other test deemed necessary for the system
7. In addition to the above tests, the following tests will be conducted at shop and site.
 - At shop
 - a) Capacity and discharge pressure of each air compressor.

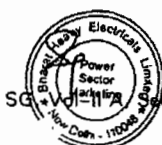

VIII, Air Comp. - NTA1

162





- b) Power consumption of each air compressor at its rated duty point with its own motor.
- At site
- a) Parallel operations of air compressors.
 - b) Dew point of air at the outlet of air drying plants of instrument air compressors.
 - c) Pressure drop across the air drying plants of air compressors.
8. Dynamic balancing of all rotating components and assembly of each air compressor including all drive motors in the compressed air system.
 9. Tests for capacity, pressure drop and efficiency of each Intake Air Filter with silencer will be as Manufacturer's standard. These tests will be conducted along with performance testing of each compressor.
 10. Testing of all drive motors and control panels in the compressed air system.
 11. Dew Point tests to be carried out on each Air Drying Plant.
 12. Any other test deemed necessary for the system.

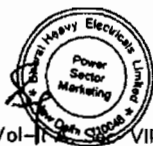



Performance testing shall be done on any one lignite mill (as per Owner's choice) per boiler toward establishing its capacity specified at the rated fineness, applying corrections for the variation in lignite characteristics i.e. HGI and moisture.

Bidder shall guarantee capacity output of any one lignite mill (as per Owner's choice) per boiler at rated fineness and shall demonstrate the same with following conditions:

a)	Lignite fineness	a) 40% pass through 0.09 mm mesh screen b) 80% pass through 0.3 mm mesh screen
b)	Mill Loading	Not to exceed 85 % of maximum load
c)	Lignite Quality	Design Lignite

Should the HGI, total moisture content and PF fineness of Lignite vary from that given in Lignite characteristics during demonstration test, corrections shall be applied to the measured capacity of mill based on the correction curves. These correction curves shall be furnished during detailed engineering and shall be subject to Owner's acceptance.

- g) The following performance criteria for the compressed air system shall be guaranteed and demonstrated by the Bidder.

Capacity of compressor in Nm³/min at rated discharge pressure of 8.5 kg/cm² (g).

- Quality of instrument air (dew point) coming out of the air dryer.
- Discharge air pressure at outlet of each compressor, kg/cm² (g)
- Discharge air temperature at outlet of each compressor, deg. C.

In general all the performance test of the plant and equipments shall be carried out as per IS: 5456 or applicable ASME - Performance Test Code.

Document Number	Rev No.	Description	Page No.	Date of Issue
LII-GEOE11019-G-00155-001	00	SG, Vol-II A, Sec-III, SG and Aux. - NTA1	96	24-Sep-12

	NNTPP, NEYVELI (2 X 500 MW)	SPECIFICATION No: PE-TS-400-555-A001	
		CUSTOMER	NLC
		VOLUME - IIB	SECTION - D
		REV	00

VOLUME – IIB
SECTION - D

STANDARD DATA SHEET FORMAT



ANNEXURE - A : SCREW TYPE AIR COMPRESSOR & AUXILIARIES

A.	PERFORMANCE DATA	
	Free Air Delivery	
	Discharge Pressure	
	Noise level near compressors	
	Vibration limit (measured at top and bottom of main bearing)	
B.	CONSTRUCTION FEATURES	
	Location	
	No. of compressors (for 2 units)	
	Type	
	Service	
	Duty	
	Type of Drive	
	Design ambient for drive	
	Number of starts per hour	
	Type of transmission	
	Antivibration arrangement required	
	Maximum temperature for any step during the cycle	
	Type of control	
	Type of Annunciation	
	Flange standard	
C.	MATERIALS OF CONSTRUCTION	
	Compressor chamber	
	Rotors	
	Bearing	
	Timing Gear	
	Base Plate	
	Inlet throttle valve & housing	
	Shaft seals	
	Safety valves	

Document Number	Rev No.	Description	Page No.	Date of Issue
LII-GEOE11019-G-00155-001	00	SG, Vol-II A, Sec- VIII, Air Comp. - NTA1	162	24-Sep-12



	Water separator	
	Blow off valve	
	Unloading Cylinder header	
	Tube of oil cooler	
	Outer casing of coolers	
	Gear Box	
	Gears	
D.	SUPPLY OF ACCESSORIES & SERVICES	
	Intake air filters with silencers	
	Intercoolers	
	Aftercoolers with moisture separators	
	All instruments as specified, as shown in tender drawing and as required for safe and trouble-free operation of the system	
	Coupling guards	
	Air receivers	
	Base plates	
	Foundation bolts, nuts, sleeves, inserts etc.	
	All interconnecting air and cooling water piping, complete with valves, fittings as shown in relevant tender drawings and as required for reliable and smooth operation of the system	
	Eye bolts, lifting tackle, tools, etc.	
	Control panels complete with all accessories	
	Instrument gauge panels complete with all accessories	
E.	AUXILIARY COOLING WATER DATA	
	Quality	
	Design inlet temperature	
	Design pressure	
	Normal inlet pressure	

Document Number	Rev No.	Description	Page No.	Date of Issue
LII-GEOE11019-G-00155-001	00	SG, Vol-II A, Sec- VIII, Air Comp. - NTA1	163	24-Sep-12



	pH value	
	Maximum pressure drop allowable between inlet and outlet points	
F.	TESTING AND INSPECTION	
	Material Testing and identification	
	Dye Penetration test	
	Type of performance test to be conducted	
	Field performance test	
	MPI and UT tests	
	All other specific tests as specified in this section	
G.	DRIVE MOTOR	
	Drive motor for compressor shall comply with ELECTRICAL section of the Specification.	
H.	COMPRESSOR ACCESSORIES	
	a) Intake Air Filter	
	Numbers required	
	Location	
	Type	
	Silencer	
	Air flow rate	
	Particle removing efficiency	
	1. Maximum allowable pressure drop at stated air flow rate in new condition of filter (viscosity of air at normal ambient temperature)	
	Test requirement	
	b) Air Receiver	
	Numbers required	
	Installation	
	Type	
	Design pressure	

Document Number	Rev No.	Description	Page No.	Date of Issue
LII-GEOE11019-G-00155-001	00	SG, Vol-II A, Sec- VIII, Air Comp. - NTA1	164	24-Sep-12



**2x500 MW, NNTPP, Neyveli
TENDER SPECIFICATION
STEAM GENERATOR & AUX. PACKAGE - NTA1**



	Hydraulic test Pressure	
	Design code	
	Capacity of each air receiver	
	Material of construction of shell	
	Material of construction of dished ends	
	Material of construction of flanges	
	Supply of Accessories & Services	
	Flanges with nuts, bolts and gaskets	
	Pressure gauge with snubber	
	Pressure switch	
	Temperature indicator	
	Relief valve	
	Trap station	
	Level gauge	
	Vent valve/plug	
	Supporting stand with necessary foundation bolts, nuts, sleeves, etc	
	Eye bolts, lifting tackle etc.	
	Painting	
	i) External	
	ii) Internal	
	Inspection and Testing	
	Material testing and identification	
	Bend test as per BS-5169	
	2. Spot radiography of circumferential and longitudinal butt welds	
	Field performance test	
	D.P. test where radiography cannot be done	
	Hydraulic Test	

Document Number	Rev No.	Description	Page No.	Date of Issue
LII-GEOE11019-G-00155-001	00	SG, Vol-II A, Sec- VIII, Air Comp. - NTA1	165	24-Sep-12



	Other specific tests as specified in Clause No. 7.00.00 of this specification	
	c) Intercooler, Aftercooler, Moisture Separator, Piping, Valves etc.	
	i) Aftercooler	
	Installation	
	Type	
	Relief Valve	
	Moisture Separator	
	Trap Station	
	Temperature Indicator	
	Temperature Switch	
	Level Gauge	
	ii) Intercooler	
	Installation	
	Type	
	Relief Valve	
	Trap Station	
	Pressure Gauge	
	Temperature Indicator	
	Temperature Switch	
	iii) Supply of Accessories and Services	
	Supporting stands with bolts, nuts and gaskets	
	Eye bolts, lifting tackle etc with tools and tackle	
	Flanged connections for supply and return of cooling water	
	iv) Material of Construction	
	Tube	
	Shell	
	Tube Sheet	
	Baffles	

Document Number	Rev No.	Description	Page No.	Date of Issue
LII-GEOE11019-G-00155-001	00	SG, Vol-II A, Sec- VIII, Air Comp. - NTA1	166	24-Sep-12



	Flanges	
v)	Cooling Water Data	
vi)	Piping, Valves and Fittings for Compressed Air System	
	Pipes for cooling water line	
	Pipes for compressed air line & interconnecting air line	
	Fittings	
	Fittings for cooling water line	
	Fittings for compressed air piping & interconnecting air piping	
	Valves for air line	
	Valves for cooling water line	
vii)	Testing and inspection	

Document Number	Rev No.	Description	Page No.	Date of Issue
LII-GEOE11019-G-00155-001	00	SG, Vol-II A, Sec- VIII, Air Comp. - NTA1	167	24-Sep-12



**TECHNICAL SPECIFICATION FOR
COMPRESSED AIR SYSTEM
2 X 500 MW NNTPS, NEYVELI**

SPEC NO. PE-TS-400-555-A001	
VOLUME-III	
REV.NO.	0

VOLUME - III

	TECHNICAL SPECIFICATION FOR COMPRESSED AIR SYSTEM 2 X 500 MW NNTPS, NEYVELI	SPEC NO. - PE-TS-400-555-A001	
		VOLUME-III	
		ANNEXURE - I	
		REV.	0

ANNEXURE - I
COMPLIANCE CUM CONFIRMATION CERTIFICATE



TITLE:
**TECHNICAL SPECIFICATION
2X500 MW NNTPS, NEYVELI**
**COMPLIANCE CUM CONFIRMATION
CERTIFICATE**

SPEC. NO.: PE-TS-400-555-A001

VOLUME: III

ANNEXURE - I

REV. NO. 0 DATE

COMPLIANCE CUM CONFIRMATION CERTIFICATE

The bidder shall confirm compliance with following by signing/ stamping this compliance certificate (every sheet) and furnish same with the offer.

- a) The scope of supply, technical details, construction features, design parameters etc. shall be as per technical specification & there are no exclusions other than those mentioned under "exclusion" and those resolved as per 'Schedule of Deviations', if applicable, with regard to same.
- b) There are no other deviations w.r.t. specifications other than those furnished in the 'Schedule of Deviations'. Any other deviation, stated or implied, taken elsewhere in the offer stands withdrawn unless specifically brought out in the 'Schedule of Deviations'.
- c) Bidder shall submit QP in the event of order based on the guidelines given in the specification & QP enclosed therein. QP will be subject to BHEL/ CUSTOMER approval & customer hold points for inspection/ testing shall be marked in the QP at the contract stage. Inspection/ testing shall be witnessed as per same apart from review of various test certificates/ Inspection records etc. This shall be within the contracted price with no extra implications to BHEL after award of the contract.
- d) All drawings/ data-sheets/ calculations etc. submitted along with the offer shall be considered for reference only, same shall be subject to BHEL/ CUSTOMER approval in the event of order.
- e) The offered materials shall be either equivalent or superior to those specified in the specification & shall meet the specified/ intended duty requirements. In case the material specified in the specifications is not compatible for intended duty requirements then same shall be resolved by the bidder with BHEL during the pre-bid discussions, otherwise BHEL/ Customer's decision shall be binding on the bidder whenever the deficiency is pointed out.

For components where materials are not specified, same shall be suitable for intended duty, all materials shall be subject to approval in the event of order.
- f) The commissioning spares shall be supplied on 'As Required Basis' & prices for same included in the base price itself.
- g) All sub vendors shall be subject to BHEL/ CUSTOMER approval in the event of order.
- h) Guarantee for plant/equipment shall be as per relevant clause of GCC /SCC /Other Commercial Terms & Conditions.
- i) In the event of order, all the material required for completing the job at site shall be supplied by the bidder within the ordered price even if the same are additional to approved billing break up, approved drawing or approved Bill of quantities. This clause will apply in case during site commissioning additional requirements emerges due to customer and/ or consultant's comments. No extra claims shall be put on this account.
- j) Schedule of drawings submissions, comment incorporations & approval shall be as stipulated in the specifications. The successful bidder shall depute his design personnel to BHEL's/ Customer's/ Consultant's office for across the table resolution of issues and to get documents approved in the stipulated time.

B2

	TITLE:	SPEC. NO.: PE-TS-400-555-A001
	TECHNICAL SPECIFICATION 2X500 MW NNTPS, NEYVELI	VOLUME: III
		ANNEXURE - I
	COMPLIANCE CUM CONFIRMATION CERTIFICATE	REV. NO. 0

k) As built drawings shall be submitted as and when required during the project execution.

l) The bidder has not tempered with this compliance cum confirmation certificate and if at any stage any tempering in the signed copy of this document is noticed then same shall be treated as breach of contract and suitable actions shall be taken against the bidder.



**TECHNICAL SPECIFICATION FOR
COMPRESSED AIR SYSTEM
2 X 500 MW NNTPS, NEYVELI**

SPEC NO. PE-TS-400-555-A001

VOLUME-III

ANNEXURE - II

REV.NO. 0

**ANNEXURE - II
SUB-VENDOR LIST**

CAS SUB-VENDOR LIST



SL No	Item	Proposed Subvendor	Place of Manufacturer
1	OIL FREE SCREW COMPRESSOR COMPLETE SKID MOUNTED WITH MOTOR, CONTROL PANEL AND ACCESSORIES	KIRSOSKAR PNEUMATIC CO. LTD. PUNE	
		ATLAS COPCO INDIA LTD. PUNE	
		INGERSOLL RAND	
		ELGI Air End from Hitachi Japan, Assembly along with Indigenous components and Testing at ELGI Works - Coimbatore	Coimbatore
2	HOC / REACTIVATED BLOWER TYPE ADP	DELAIR	GURGAON
		SUMMITS	COIMBATORE
		MELLCON	NEW DELHI
		ATLAS COPCO Testing at Atlas Copco Works - Pune	Belgium (Pune)
3	MS/GI Pipes –ERW IS 1239 / IS 3589 (Quantity < 200 meters Assorted sizes)	PSL	
		Jindal (upto 350NB)	Ghaziabad
		Surya Roshni (upto 400NB)	Bahadurgarh
		TISCO	Jamshedpur
		Indian Seamless SAW	
		Rama Steel tubes	
		Ankit Roofing (GRP)	
		Maharashtra seamless (200 to 500 NB) IS 3589	Raigad
4	Forged/Formed fittings	EBY	Taloja
		Siddarth & Gautam	Faridabad
		Pipefit	Baroda
		MS Fittings	Kolkata
		Tube Products	Baroda
		Bharat Forge	Pune
		NL Hazra	Kolkata
5	Ball Valve	Precision Engg	Nasik
		Microfinish Valves Ltd	Hubli
		BDK engg Industries	Hubli
		Flow chem. Industries	Ahemdabad
		Audco	Chennai
		Akay India	Hubli
6	CS/FS Gate/Globe/Check valves Upto 600 NB 150 Class, 50 NB 800 Class	Fouress	Mumbai/ Aurangabad
		BDK	Hubli
		Audco	Chennai
		Leader	Jullundhar
		KSB	Coimbatore
		KBL	Kondhapuri
7	Butterfly Valve (Upto 500 NB)	KBL	Kondhapuri

CAS SUB-VENDOR LIST_Bulk tender.xls

SL No	Item	Proposed Subvendor	Place of Manufacturer
	PN 16)	Fouress	Bangalore
		Audco	Chennai
		BDK	Hubli
		Tyco	Halol
		Inter Valve	Pune
8	Air Receiver	Integrated Engineers	Mumbai
		Diamond Fabricators	Pune
		Parkaire	Delhi
		Temasme Vesselex	Noida
		United Engineering Works	Nasik
9	Safety Relief Valve	LEADER	JALANDHAR
		SPIRAX MARSHALL	PUNE
		FISCHER SANMAR	CHENNAI
10	Pr./Vacuum/Dp Gauges	Auxitrol	U.K
		Switzer (for DP gauge)	Chennai
		Budenburg	U.K
		A.N.Instruments	Kolkata
		Bells Control	Kolkata
		Manometer India	Mumbai
		H Guru	Muzzafarpur / Risra
		General Inst.	Mumbai/Goa
		Gluck India	Mumbai
		11	Pr./Vacuum/DP.switch
Barton Inst.system	USA		
Gauges Bourdon	Mumbai		
Switzer	Chennai		
12	Temperature Gauge	Budenburg	U.K
		A.N.Instruments	Kolkata
		Bells Control	Kolkata
		H Guru	Muzzafarpur / Risra
		General Inst.	Mumbai/Goa
13	Temperature Transmitter	(ABB)	Faridabad / Germany
		Yokogawa	Japan
		Emerson (Rosemount)	USA
14	Pr./DP Transmitter	(ABB) -2600T series	Faridabad/Italy
		Honeywell	USA/India
		Fuji	Japan
		Emerson (Rosemount)	USA
		Emerson (Rosemount)	Daman
		Yamatake	
		Endress & Hauser	
		Yokogawa	Japan
15	HT Motor for Air compressor	CGL	Mandideep
		Marathon Electric	Kolkata
		BHEL	Bhopal
		SIEMENS	Germany
		Hyosung	Korea
		Hyundai	Korea
16	Flow Switch	Switzer	Chennai
		Levecon	Kolkata
		DK Instruments	Kolkata

CAS SUB-VENDOR LIST_Bulk tender.xls

SL No	Item	Proposed Subvendor	Place of Manufacturer
		Delta	UK
		ITT Barton	USA
17	Temp Sensor	Pyro Electric	Mumbai
		Detriv	Mumbai
18	Flow Indicator	Sigma	Mumbai
		Eureca	Pune
19	Auto Drain Trap	Main Contractor approved sources	
20	Dew point meter	GE Sensing	Ireland
		Michell Instruments	UK
		Shaw	UK
21	Flow Meter / Rota Meter	Trac	Hyderabad
		Eureca	Pune
22	Level Indicator/ Gauge	Sigma	Mumbai
		Levcon	Kolkata
		Pune Techtrol	Pune
		SBEM	Pune
23	Solenoid Valve	HERION	GERMANY/ ITALY
		ROTEX AUTOMATION LTD.	V V NAGAR/ BARODA
		ASCO	CHENNAI
		JEFFERSON	ARGENTINA
		AVCON	MUMBAI
24	Cable trays (max 300 meters)	SHRENK AND COMPANY	
		PREMIER POWER PRODUCTS	
		RELIANCE CABLE TRAY	
		PATNI CABLE TRAY	
		SADHNA CABLE TRAYS	
		SHRUTI INDUSTRIES	
		STEELITE ENGINEERS LTD	
		SAMISTHY	
		PROFAB	
		INDIANA ENGINEERING LTD	MUMBAI
25	Cable Glands	SUNIL & COMPANY	KOLKATA
		ARUP ENGG	KOLKATA
		COMMET	MUMBAI
		QUALITY PRECISION	KOLKATA
26	Cable Lugs	DOWELLS	MUMBAI
		CHETNA ENGG	NASIK
		3D	VALSAD
27	Control cable	FINOLEX CABLES, PUNE	
		POLY CAB INDUSTRIES, BARODA	
		RPG CABLES	
		TORRENT CABLES	
		NICCO CABLES	
		UNIVERSAL CABLES	
		KEI	

CAS SUB-VENDOR LIST_Bulk tender.xls

SL No	Item	Proposed Subvendor	Place of Manufacturer
		DELTON	
		CCI	
		ISHWAR METAL INDUSTRIES	
		ISHWAR CABLES PVT LTD	
		DAKSHA (only for Control cables)	
		ROMESH CABLES	
		ROLLEX	
		ALPHA COMMUNICATION	
		GEMSCAB	
		TIRUPATI (only for Control cables)	
28	Instrument cable	ASSOCIATED CABLES (P) LTD.	
		POLYCAB WIRES PVT LTD.	
		UNIVERSAL CABLES	
		GEMS CAB.	
		DELTON CABLES LTD.	
		CORDS CABLES INDS. PVT. LTD	
		SKYTONE ELECTRICALS (INDIA) LTD.	
		NICCO CORP.LTD	
29	Junction Box	Main Contractor Approved Sources	

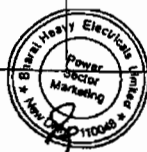

10.2 List of Sub Vendors - Mechanical

SL.NO	EQUIPMENT/ INSTRUMENT	CATEGORY-I	CATEGORY-II
<i>Class I Items</i>			
1	Air compressors	1. ATLAS COPCO (INDIA) LTD. 2. ELGI EQUIPMENTS LTD 3. CHICAGO PNEUMATIC SALES 4. INGERSOLL- RAND (INDIA) LTD. 5. KIRLOSKAR PNEUMATIC CO. LTD.	1. BHARAT PUMPS & COMPRESSORS LTD. 2. DRESSER RAND INDIA PVT LTD 3. KOBELCO
2	Aux. PRDS for control valves (Pressure & Temperature)	1. CONTROL COMPONENTS INC. USA. 2. INSTRUMENTATION LTD. INDIA 3. ARCA REGLER GMBH. GERMANY 4. FORBES MARSHALL, INDIA 5. YARWAY CORPORATION, INDIA 6. HOLTER REGELARMATUREN GMBH & CO., KG 7. COPES VULCAN LTD., UK 8. CCI VALVE TECHNOLOGY, INDIA	1. SPX FLOW TECHNOLOGY, UK. 2. BTG KALLE INVENTING AB. SWEDEN. 3. SPX FLOW TECHNOLOGY(INDIA)PVT LTD 4. LESLIE CONTROLS INC. USA. 5. BOMAF A ARMATUREN GMBH. GERMANY. 6. FS CURTIS, INDIA 7. CIRCOR FLOW TECHNOLOGIES, INDIA 8. CHEMTROLS INDUSTRIES
3	Boiler circulating water pump	1. HAYWARD TYLER LTD 2. TORISHIMA PUMP MFG CO.LTD 3. KSB AKTIENGESELLSCHAFT	1. SHENYANG BLOWER WORKS GROUP 2. V-FLO PUMPS & SYSTEMS
4	Beater wheel Mill components		
a)	Beater Wheel	1.ALSTOM	1. TYAZHMASH, RUSSIA 2. BABCOCK BORSIG STEINMÜLLER GMBH, GERMANY 3. VITKOVICE GEARWORKS 4. ALSTOM PROJECTS INDIA PVT LTD., 5. TOTEMA ENGINEERING JSC
b)	Lube oil system	1. ALSTOM 2. SOUTHERN LUBRICATIONS PVT LTD, BANGALORE 3. CENLUB INDUSTRIES LTD, FARIDABAD 4. LINCOLN HELIOS (INDIA) LTD, BANGALORE	1. PSI ENGINEERING SYSTEM, CHENNAI. 2. TYAZHMASH, RUSSIA 3. BABCOCK BORSIG STEINMÜLLER GMBH, GERMANY 4. VITKOVICE GEARWORKS 5. ALSTOM PROJECTS INDIA PVT LTD., 6. TOTEMA ENGINEERING JSC
5	Seal air fans	1. BHEL 2. C.DOCTOR, INDIA	1. INDUSTRIAL FANS, INDIA 2. FLAKT WOOD, INDIA 3. ANDREW YULE 4. BATLIBOI INDUSTRIES, INDIA 5. NADI INDUSTRIAL FANS 6. FLUID AIRE TECHNOLOGIST



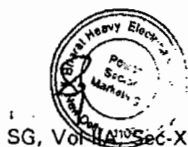

SL.NO	EQUIPMENT/ INSTRUMENT	CATEGORY-I	CATEGORY-II
		<ol style="list-style-type: none"> 4. MINWOOL ROCK FIBRES LTD,INDIA 5. GOENKA ROCKWOOL (INDIA) PVT.LTD. INDIA 6. THERMO-CARE ROCKWOOL (I) PVT.LTD INDIA 7. LLOYDS INSULATION (INDIA) LTD., 8. BASKAR REFRACTORIES & S W PIPES (P) LTD., 9. DALMIA REFRACTORIES 	<ol style="list-style-type: none"> 4. JAMSHEDPUR MINERAL WOOL MFG.CO., JAMSHEDPUR 5. HYDERABAD INDUSTRIES LTD., INDIA
12.	Butterfly valves	<ol style="list-style-type: none"> 1. INTER VALVE (INDIA) LTD. INDIA. 2. TYCO VALVES & CONTROLS INDIA P.LTD, INDIA 3. LARSEN & TOUBRO LTD (CTRL & AUTOMN), INDIA 4. INSTRUMENTATION LTD, INDIA. 5. FOURS ENGINEERING (I) LTD. INDIA. 6. KSB PUMPS LTD. 7. BHEL 8. B.D.K.ENGINEERING INDUSTRIES LTD. 9. LEADER VALVES 10. KIRLOSKAR BROTHERS LTD., 11. ADVANCE VALVES PVT LTD., 12. FLUIDLINE VALVES CO. PVT. LIMITED , MUMBAI 13. L&T AUDCO 14. CRESCENT VALVES MFG. CO. (P) LTD. 15. A.V. VALVES LTD. 16. VENUS PUMPS & ENGG. WORKS 17. MICON VALVES INDIA PVT. LTD. 18. NITON IND. LTD. 19. PETROL VALVES S.R.L., ITALY 20. STEELSTRONG VALVES (INDIA) PVT. LTD., MUMBAI 21. BABCOCK BORSIG ESPANA, SA 22. SURYA VALVES AND INST. MFG. CO., CHENNAI 23. INTERVALVE INDIA LTD. 24. SANT VALVES PVT LTD., 25. H SARKER & CO., 26. G.M.DALUI & SONS 27. INSTRUMENTATION LTD 	<ol style="list-style-type: none"> 1. WEIR BDK VALVES-A UNIT OF WEIR. INDIA 2. WEIR VALVES AND CONTROLS M.E. 3. FEDERAL HARDWARE ENGG. CO PTE LTD., SINGAPORE 4. VALTECH INDUSTRIES., MUMBAI 5. NSSL LTD 6. OSWAL INDUSTRIES LTD. 7. STAFFORD CONTROLS LTD. PUNE 8. R & D MULTIPLES (METAL CAST) PVT. LTD. 9. CRANE PROCESS, INDIA 10. ALFA LAVAL, INDIA 11. MICROFINISH VALVES, INDIA 12. DEMBLA VALVES, INDIA 13. EAGLE PONNAWALLIA, INDIA 14. GLOBE 15. VAAS INDUSTRIES 16. TULIP VALVES 17. V TORK CONTROLS 18. HAWA ENGINEERS LTD 19. AQUA VALVES 20. BDK PROCESS CONTROLS PVT.LTD.





SL.NO	EQUIPMENT/ INSTRUMENT	CATEGORY-I	CATEGORY-II
13.	Air release valves	1. KSB PUMPS LTD. 2. BHEL 3. B.D.K.ENGINEERING INDUSTRIES LTD. 4. FOURESS ENGG. (I) LTD. 5. LEADER VALVES 6. KIRLOSKAR BROTHERS LTD., 7. ADVANCE VALVES PVT LTD., 8. FLUIDLINE VALVES CO. PVT. LIMITED , MUMBAI 9. L&T AUDCO 10. CRESCENT VALVES MFG. CO. (P) LTD. 11. A.V. VALVES LTD. 12. VENUS PUMPS & ENGG. WORKS 13. MICON VALVES INDIA PVT. LTD. 14. NITON IND. LTD. 15. PETROL VALVES S.R.L., ITALY 16. STEELSTRONG VALVES (INDIA) PVT. LTD., MUMBAI 17. BABCOCK BORSIG ESPANA, SA 18. SURYA VALVES AND INST. MFG. CO., CHENNAI 19. TYCO VALVES AND CONTROLS INDIA PVT. LTD., HALOL 20. INTERVALVE INDIA LTD. 21. SANT VALVES PVT LTD., 22. H SARKER & CO., 23. G.M.DALUI & SONS 24. INSTRUMENTATION LTD.	1. WEIR VALVES AND CONTROLS M.E. 2. FEDERAL HARDWARE ENGG. CO PTE LTD., SINGAPORE 3. VALTECH INDUSTRIES., MUMBAI 4. NSSL LTD 5. OSWAL INDUSTRIES LTD. 6. STAFFORD CONTROLS LTD. PUNE 7. R & D MULTIPLES (METAL CAST) PVT. LTD. 8. CRANE PROCESS, INDIA 9. ALFA LAVAL, INDIA 10. MICROFINISH VALVES, INDIA 11. DEMBLA VALVES, INDIA 12. EAGLE PONNAWALLIA, INDIA 13. GLOBE 14. VAAS INDUSTRIES 15. TULIP VALVES 16. V TORK CONTROLS 17. HAWA ENGINEERS LTD 18. AQUA VALVES
14.	Ball valves	1. AKAY INDUSTRIES PVT.LTD 2. KSB PUMPS LTD. 3. LEADER VALVES LTD. 4. MICROFINISH VALVES PVT LTD. 5. DEMBLA VALVES LTD. 6. BHEL 7. B.D.K.ENGINEERING INDUSTRIES LTD. 8. FOURESS ENGG. (II) LTD. 9. KIRLOSKAR BROTHERS LTD., 10. ADVANCE VALVES PVT LTD., 11. FLUIDLINE VALVES CO. PVT. LIMITED , MUMBAI 12. L&T AUDCO 13. CRESCENT VALVES MFG. CO. (P) LTD. 14. A.V. VALVES LTD. 15. VENUS PUMPS & ENGG.	1. A.V. VALVES LTD 2. BELGAUM AQUA VALVES PVT. LTD. 3. ASIAN INDUSTRIAL VALVES & INSTRUMENTS. 4. ATAM VALVES PVT. LTD. 5. BOTELI VALVE GROUP CO. LTD. 6. FLUIDLINE VALVES COMPANY PVT.LTD. 7. M/S GM ENGINEERING 8. SAKHI ENGINEERS PVT.LTD. 9. VALTECH INDUSTRIES 10. VAAS AUTOMATION PVT. LTD. 11. WEIR BDK VALVES- A UNIT OF WEIR 12. MICON ENGINEERS (HUBLI)





SL.NO	EQUIPMENT/ INSTRUMENT	CATEGORY-I	CATEGORY-II
		WORKS 16. MICON VALVES INDIA PVT. LTD. 17. NITON IND. LTD. 18. PETROL VALVES S.R.L., ITALY 19. STEELSTRONG VALVES (INDIA) PVT. LTD., MUMBAI 20. BABCOCK BORSIG ESPANA, SA 21. SURYA VALVES AND INST. MFG. CO., CHENNAI 22. TYCO VALVES AND CONTROLS INDIA PVT. LTD., HALOL 23. INTERVALVE INDIA LTD. 24. SANT VALVES PVT LTD., 25. H SARKER & CO., 26. G.M.DALUI & SONS 27. INSTRUMENTATION LTD.	PVT.LTD.,,India 13. UNIFLOW,,India 14. VOLTECH MANUFACTURING COMPANY LTD.,,India 15. ZED VALVES CO.PVT.LTD.,,India
15.	Flash tanks	1. ANSALDO CALDAIE 2. TECHNO FAB, INDIA 3. UNITECH MACHINES, INDIA 4. THERMO PAD, INDIA	1. BEND JOINTS PVT LIMITED,India 2. MAS STEEL FABRICATORS,India 3. S&G ENGINEERS PRIVATE LIMITED,India 4. SAKTHI HI-TECH CONTSTRN. (P) LTD,India 5. SEAM INDUSTRIES LIMITED,India 6. SOUTHERN HEAVY ENGINEERING PVT. LTD,India 7. TRIMECH ENGINEERING PVT. LTD, India 8. UNITECH MACHINES LIMITED,India 9. Vijay Tanks and Vessels, india
16.	G.M. gate/globe/ NRV	1. KSB PUMPS LTD. 2. BHEL 3. B.D.K.ENGINEERING INDUSTRIES LTD. 4. FOURESS ENGG. (I) LTD. 5. LEADER VALVES 6. FLUIDLINE VALVES CO. PVT. LIMITED, MUMBAI 7. L&T AUDCO 8. CRESCENT VALVES MFG. CO. (P) LTD. 9. A.V. VALVES LTD. 10. VENUS PUMPS & ENGG. WORKS 11. MICON VALVES INDIA PVT.	1. WEIR VALVES AND CONTROLS M.E. 2. FEDERAL HARDWARE ENGG. CO PTE LTD., SINGAPORE 3. VALTECH INDUSTRIES., MUMBAI 4. NSSL LTD. 5. OSWAL INDUSTRIES LTD. 6. ADVANCE VALVES PVT. LTD. 7. STAFFORD CONTROLS LTD. PUNE 8. R & D MULTIPLES (METAL CAST) PVT. LTD. 9. GLOBE

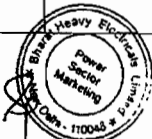



SL.NO	EQUIPMENT/ INSTRUMENT	CATEGORY-I	CATEGORY-II
		LTD. 12. NITON IND. LTD. 13. PETROL VALVES S.R.L., ITALY 14. STEELSTRONG VALVES (INDIA) PVT. LTD., MUMBAI 15. BABCOCK BORSIG ESPANA, SA 16. SURYA VALVES AND INST. MFG. CO., CHENNAI 17. KIRLOSKAR BROTHERS LTD. 18. SANT VALVES PVT. LTD 19. TYCO VALVES AND CONTROLS INDIA PVT. LTD., HALOL 20. INTERVALVE INDIA LTD 21. G.M.DALUI & SONS 22. H.SARKER & CO. 23. INSTRUMENTATION LTD	10. HAWA ENGINEERS LTD
17.	Gate valve (steel)	1. FLUID CONTROLS PRIVATE LTD. MUMBAI 2. POWER PIPING CO. CHENNAI 3. KSB PUMPS LTD. 4. BHEL 5. B.D.K.ENGINEERING INDUSTRIES LTD. 6. FOURESS ENGG. (I) LTD. 7. LEADER VALVES 8. FLUIDLINE VALVES CO. PVT. LIMITED , MUMBAI 9. L&T AUDCO 10. CRESCENT VALVES MFG. CO. (P) LTD. 11. A.V. VALVES LTD. 12. VENUS PUMPS & ENGG. WORKS 13. MICON VALVES INDIA PVT. LTD. 14. NITON IND. LTD. 15. PETROL VALVES S.R.L., ITALY 16. STEELSTRONG VALVES (INDIA) PVT. LTD., MUMBAI 17. BABCOCK BORSIG ESPANA, SA 18. SURYA VALVES AND INST. MFG. CO., CHENNAI 19. KIRLOSKAR BROTHERS LTD. 20. SANT VALVES PVT. LTD 21. TYCO VALVES AND CONTROLS INDIA PVT. LTD., HALOL 22. INTERVALVE INDIA LTD	1. ARYA CRAFTS & ENGINEERING PVT.LTD. VADODARA DT. 2. COMFIT & VALVES PVT LTD. DIST. MEHSANA 3. FLOWEZY HYDRAULICS PRIVATE LTD. MUMBAI FLOWTECH, KOLKATA 4. FLOWTECH KOLKATA 5. H.P.VALVES & FITTINGS CHENNAI 6. HONEST ENGINEERING WORKS MUMBAI 7. METPRESS ENGINEERING WORKS KOLKATTA 8. MULTIMETAL INDUSTRIES BARODA 9. PRECISION ENGINEERING INDUSTRIES MUMBAI 10. VALTEX INDIA MUMBAI 11. WEIR VALVES AND CONTROLS M.E. 12. FEDERAL HARDWARE ENGG. CO PTE LTD., SINGAPORE 13. VALTECH INDUSTRIES., MUMBAI 14. NSSL LTD. 15. OSWAL INDUSTRIES LTD. 16. ADVANCE VALVES PVT. LTD. 17. STAFFORD CONTROLS LTD. PUNE





SL.NO	EQUIPMENT/ INSTRUMENT	CATEGORY-I	CATEGORY-II
		23. G.M.DALUI & SONS 24. H.SARKER & CO. 25. INSTRUMENTATION LTD	18. R&D MULTIPLES (METAL CAST) PVT. LTD. 19. GLOBE 20. HAWA ENGINEERS LTD
18.	Globe valve (steel)	1. FLUID CONTROLS PRIVATE LTD.MUMBAI 2. POWER PIPING CO. CHENNAI 3. KSB PUMPS LTD. 4. BHEL 5. B.D.K.ENGINEERING INDUSTRIES LTD. 6. FOURESS ENGG. (II) LTD. 7. LEADER VALVES 8. FLUIDLINE VALVES CO. PVT. LIMITED , MUMBAI 9. L&T AUDCO 10. CRESCENT VALVES MFG. CO. (P) LTD. 11. A.V. VALVES LTD. 12. VENUS PUMPS & ENGG. WORKS 13. MICON VALVES INDIA PVT. LTD. 14. NITON IND. LTD. 15. PETROL VALVES S.R.L., ITALY 16. STEELSTRONG VALVES (INDIA) PVT.LTD., MUMBAI 17. BABCOCK BORSIG ESPANA, SA 18. SURYA VALVES AND INST. MFG. CO., CHENNAI 19. KIRLOSKAR BROTHERS LTD. 20. SANT VALVES PVT. LTD 21. TYCO VALVES AND CONTROLS INDIA PVT. LTD., HALOL 22. INTERVALVE INDIA LTD 23. G.M.DALUI & SONS 24. H.SARKER & CO. 25. INSTRUMENTATION LTD	1. ARYA CRAFTS & ENGINEERING PVT.LTD. VADODARA DT. 2. COMFIT & VALVES PVT LTD. DIST. MEHSANA 3. FLOWEZY HYDRAULICS PRIVATE LTD. MUMBAI 4. FLOWTECH KOLKATA 5. H.P.VALVES & FITTINGS CHENNAI 6. HONEST ENGINEERING WORKS MUMBAI 7. METPRESS ENGINEERING WORKS KOLKATTA 8. MULTIMETAL INDUSTRIES BARODA 9. PRECISION ENGINEERING INDUSTRIES MUMBAI 10. VALTEX INDIA MUMBAI 11. WEIR VALVES AND CONTROLS M.E. 12. FEDERAL HARDWARE ENGG. CO PTE LTD., SINGAPORE 13. VALTECH INDUSTRIES., MUMBAI 14. NSSL LTD. 15. OSWAL INDUSTRIES LTD. 16. ADVANCE VALVES PVT. LTD. 17. STAFFORD CONTROLS LTD. PUNE 18. R&D MULTIPLES (METAL CAST) PVT. LTD. 19. GLOBE HAWA ENGINEERS LTD
19.	Low pressure piping	1. UNITECH MACHINES LIMITED,India	1. BEND JOINTS PVT LIMITED,India 2. DEE DEVELOPMENT ENGINEERS LTD.,,India 3. FLASH FORGE PVT LTD.,,India 4. IMECO LIMITED,,India 5. LARSEN & TOUBRO LTD, India 6. POWER PIPING CO.,,India 7. S&G ENGINEERS PRIVATE





SL.NO	EQUIPMENT/ INSTRUMENT	CATEGORY-I	CATEGORY-II
			LIMITED, India 8. SAKTHI HI-TECH CONTSTRN. (P) LTD, India 9. SEAM INDUSTRIES LIMITED, India 10. TRIOMECH ENGINEERING PVT.LTD, India
20	Misc. Tanks	1. TECHNO FAB, INDIA 2. THERMO PAD, INDIA 3. VIJAY TANKS AND VESSELS, INDIA 4. UNITECH MACHINES, INDIA	1. BEND JOINTS PVT LIMITED,INDIA 2. MAS STEEL FABRICATORS,INDIA 3. S&G ENGINEERS PRIVATE LIMITED,INDIA 4. SAKTHI HI-TECH CONTSTRN. (P) LTD,INDIA 5. SEAM INDUSTRIES LIMITED,INDIA 6. SOUTHERN HEAVY ENGINEERING PVT. LTD,INDIA
21.	Non return (steel) valves	1. LEADER 2. BDK 3. KSB 4. FOURESS	
22	Submersible pumps	1. M/S. KILOSKAR BROTHERS LIMITED, MUMBAI (KBL) 2. WPIL 3. SULZER 4. FLOWMORE 5. M/S. MATHER & PLATT LIMITED, PUNE.	
23.	Sump pumps	1. KBL 2. KSB 3. SU MOTORS 4. KISHORE PUMPS	
24.	Dual plate check valves	1. AV VALVES 2. LEADER 3. BDK 4. KSB 5. FOURESS LTD BANGALORE	





SL. NO	EQUIPMENT/ SYSTEM	CATEGORY-I	CATEGORY-II
		17) RAVIN CABLES LTD 18) RELIANCE ENGINEERS LTD., 19) RPG CABLES 20) TORRENT CABLES LTD. 21) UNIVERSAL CABLES LTD	19) THERMO ELECTRIC INTERNATIONAL 20) THERMOCABLES LIMITED, HYDERABAD 21) UNIFLEX CABLES LIMITED, VALSAD
28.	L.T. CONTROL CABLES	1) BRIMSON CABLES PVT.LTD., DELHI 2) CABLE CORPORATION OF INDIA LTD. 3) CMI LTD 4) CORDS CABLE INDUSTRIES LTD. 5) CRYSTAL CABLE 6) DELTON CABLES LIMITED, NEW DELHI 7) FORT GLOSTER INDUSTRIES LTD. 8) GEMSCAB INDUSTRIES LTD. 9) GOYOLENE FIBERS (INDIA) PVT. LTD. 10) HAVELLS INDIA LTD. 11) HINDUSTHAN VIDYUT PRODUCTS LTD. 12) INCAB 13) INDUSTRIAL CABLES (INDIA) LTD 14) KEI INDUSTRIES LTD. 15) KRISHNA ELECTRICAL INDUSTRIES LTD. 16) NICCO COPORATATION LTD 17) PARAMOUNT CABLES 18) POLYCAB 19) RADIANT CABLES PRIVATE LIMITED 20) RAVIN CABLES LIMITED 21) RELIANCE ENGINEERS LTD. 22) RPG CABLES LTD. 23) SUYOG CABLE 24) TORRENT CABLES LTD. 25) UNIVERSAL CABLE	1) ADVANCE CABLE TECHNOLOGIES (P) LTD. 2) ASSOCIATED CABLES PVT LTD, MUMBAI 3) BICC CABLES LIMITED, UK 4) DIAMOND POWER INFRASTRUCTURE LTD 5) ELKAY TELELINKS LIMITED, FARIDABAD 6) GOVIND CABLE INDUSTRIES, KOLKATA 7) KEC INTERNATIONAL LIMITED 8) LEONI KERPEN GMBH, GERMANY 9) MANSFIELD CABLE COMPANY LTD., NOIDA 10) RPG RAYCHEM 11) SARK CABLES PVT.LTD., PALAKKAD 12) SCOT INNOVATION WIRES AND CABLES PVT. LTD. 13) SERVEL UDYOG (P) LTD., FARIDABAD 14) SPECIAL CABLES PVT. LTD. 15) SUYOG ELECTRICALS LTD 16) THERMO CABLES LTD. 17) THERMO ELECTRIC INTERNATIONAL 18) THERMOCABLES LIMITED, HYDERABAD 19) UNIFLEX CABLES LIMITED, VALSAD





2x500 MW NNTPP, Neyveli
 CONTRACT SPECIFICATION
 STEAM GENERATOR & AUX. PACKAGE - NTA1



SL. NO	EQUIPMENT/ SYSTEM	CATEGORY-I	CATEGORY-II
29.	CABLE TERMINATION & JOINTING KITS	1) CABLE CORPORATION OF INDIA 2) RPG 3) YAMUNA POWER & INFRA STRUCTURE LTD. 4) RAYCHEM RPG PRIVATE LTD 5) 3M ELECTRO AND COMMUNICATION INDIA P LTD	1) KEI 2) SUNIL & COMPANY PVT. LTD. 3) HARI CONSOLIDATED PVT LTD NEW DELHI
30.	CABLE LUGS	1) 3M ELETRO AND COMMUNICATION 2) COMET 3) DOWELLS 4) ELECTROMAG INDUSTRIES 5) JAINSON	1) CHETNA ENGINEERING CO. NASHIK 2) DIVYAJOTHY LUGS PVT LTD BANGALORE 3) ELECTROTECH 4) HEX 5) KRISHNA COMMERCIAL CORPORTION, CHENNAI 6) LOTUS 7) RAYCHEM 8) RPG 9) UNIVERSAL MACHINES
31.	ELECTRICAL ACTUATORS	1) ANTRIEB 2) AUMA (INDIA) 3) LIMITORQUE INDIA 4) ROTORK CONTROLS LIMITED UK. 5) ROTORK CONTROLS LTD. (INDIA)	1) ANTRIELS TECNICK 2) INSTRUMENTATION LTD. KERELA 3) KELTRON CONTROLS AROOR 4) R.G.S.ELECTRO-PNEUMATICS LTD.UK 5) ROTEX MANUFACTURERS & MUMBAI 6) WEIR BDK VALVES-A UNIT OF WEIR HUBLI
32.	KWHR METERS	1) AUTOMATIC ELECTRIC 2) ENERCON 3) L&T 4) RISHABH 5) SECURE	1) ANTRIELS TECNICK 2) BHEL (EDN) 3) CONZERV 4) IMP 5) M.B CONTROLS 6) MECO 7) METERS & INSTRUMENTS 8) SIMCO 9) TTL 10) UNIVERSAL
33.	TRANSDUCER	1) ABB 2) AE 3) ELSTER METERING 4) MECO 5) PYROTECH 6) RISHAB	1) ADEPT, PUNE





SL. NO	EQUIPMENT/SYSTEM	CATEGORY-I	CATEGORY-II
		PERFORATIONS (INDIA) PVT. LTD 5) JAMNA METAL COMPANY 6) PATNY SYSTEMS (P) LTD 7) PRAMMEN INDUSTRIES 8) PREMIER POWER PRODUCTS (CALCUTTA) PVT LTD 9) RATAN ENGG CO. PVT. LTD 10) STEELMITE ENGINEERING, PONDICHERY	4) BALIGA LIGHTING EQUIPMENTS PVT. CHENNAI 5) CAUVERY ENGG/PUDUKOTTAI 6) GLOBE ELECTRIC INDUSTRIES 7) INDIA ELECTRICALS SYNDICATE, KOLKATA 8) INDUSTRIAL CORPORATION 9) KANADE ANAND UDYOG PVT. LTD., MUMBAI 10) M META PRINTINDUSTRIES/CHENNAI 11) PARMER METALS/RAJKOT 12) POWER LOGIC 13) PREMIER POWER PRODUCTS 14) RABI ENGG WORKS 15) RABI ENGINEERING WORKS PVT. LTD. 16) RUKMANI ELECTRICAL & COMPONENTS PVT LTD 17) STEELITE ENGG. LTD. MUMBAI 18) UNITECH FABRICATORS and ENGINEERS PVT LTD 19) VATCO 20) VINFAB ENGINEERS, THANE
2.	CABLE GLANDS	1) BRACO 2) CABLE CORPORATION OF INDIA 3) CENTRAL HARDWARE 4) CHW 5) COMET 6) COSMOS 7) DOWELLS 8) ELECTROMAC INDUSTRIES 9) ELECTROMAT 10) FLAME PROOF CONTROL GEARS 11) GLAND-MECH INDUSTRIES KOLKATA. 12) HEX 13) JIMSON 14) MAHAVEER ENGG 15) SUNIL & CO.	1) ALLIED TRADERS 2) ARUP ENGG. & FOUNDRY WORKS 3) BALIGA LIGHTING EQPT. 4) ELEXPRO ELECTRICALS 5) INCAB 6) PROMPT ENGG WORKS MUMBAI 7) SARATHI TRADING CO. TRICHY 8) SCG EX D TECH PVT. LTD. CHENNAI 9) STANDARD METAL INDUSTRIES
3.	LOCAL PUSH BUTTON STATION	1) BCH 2) BHEL-EPD 3) L&T 4) RAM E&I	1) BRACO 2) GE POWER CONTROL 3) HAVELLS

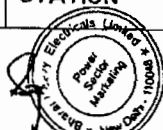



2x500 MW NNTPP, Neyveli
 CONTRACT SPECIFICATION
 STEAM GENERATOR & AUX. PACKAGE - NTA1



SL. NO.	ITEM DESCRIPTION	CATEGORY-I	CATEGORY-II
3.	PRINTERS	EPSON CANNON HP XEROX TVS (for dot-matrix only)	WIPRO TVS ABB SIEMENS LEXMARK IBM
4.	NETWORK SWITCH	D-LINK	SIEMENS JUPITER EXTREME
5.	PRESSURE TRANSMITTER	ABB E + H EMERSON PROCESS MANAGEMENT HONEYWELL YOKOGAWA SIEMENS FUJI EMERSON PROCESS ENDRESS + HAUSER	SMAR CHEMTROLS INDUSTRIES LTD, MUMBAI
6.	DP TRANSMITTER	ABB E + H EMERSON PROCESS MANAGEMENT HONEYWELL YOKOGAWA SIEMENS FUJI EMERSON PROCESS ENDRESS + HAUSER	CHEMTROLS INDUSTRIES LTD,
7.	TEMPERATURE TRANSMITTER	ABB E + H EMERSON PROCESS MANAGEMENT HONEYWELL YOKOGAWA SIEMENS EMERSON PROCESS ENDRESS + HAUSER	MCIH MOORE,USA





SL. NO.	ITEM DESCRIPTION	CATEGORY-I	CATEGORY-II
8.	THERMOCOUPLES	DETRIEV INSTRUMENTATION GENERAL INSTRUMENTS CONSORTIUM INDUSTRIAL INSTRUMENTS, KOLKATA PYROELECTRIC INSTRUMENTS GOA PVT. LTD TEMP SEN INSTRUMENTS (I) PVT. LTD. ALTOP TEMPESENS INSTRUMENTS (I) PVT. LTD. DETRIVE, MUMBAI PYRO ELEC INSTRUMENTS GOA P LTD TEMPESENS INSTRUMENTS (I) PVT LTD, UDAIPUR ALTOP INDUSTRIES LTD. INDIA	PYROELECTRONICS ABB SIEMENS TECHNO INSTRUMENTS KALOL EXOTHERM INSTRUMENTS MUMBAI
9.	RTD	DETRIEV INSTRUMENTATION GENERAL INSTRUMENTS CONSORTIUM INDUSTRIAL INSTRUMENTS, KOLKATA PYROELECTRIC INSTRUMENTS GOA PVT. LTD TEMP SEN INSTRUMENTS (I) PVT. LTD ALTOP DETRIV, MUMBAI PYRO ELEC INSTRUMENTS GOA P LTD TEMPESENS INSTRUMENTS (I) PVT LTD, UDAIPUR ALTOP INDUSTRIES LTD. INDIA	PYROELECTRONICS ABB SIEMENS INDUSTRIAL INSTRUMENTS, KOLKATA TECHNO INSTRUMENTS KALOL JINDAL ELECTRONICS PRIVATE LIMITED, - PROCESS CONTROLS (INDIA R.J.INDUSTRIAL CORPORATION GHANACON PRODUCTS, EXOTHERM INSTRUMENTS MUMBAI GOA INSTRUMENT INDUSTRIES PVT LTD., India
10.	METAL TEMPERATURE THERMOCOUPLES	DETRIEV INSTRUMENTATION GENERAL INSTRUMENTS CONSORTIUM INDUSTRIAL INSTRUMENTS, KOLKATA PYROELECTRIC INSTRUMENTS GOA PVT. LTD TEMP SEN INSTRUMENTS (I) PVT. LTD SIEMENS ALTOP ALTOP INDUSTRIES LTD. INDIA PYRO ELECTRIC CABLES AND GOA	PYROELECTRONICS ABB EXOTHERM INSTRUMENTS MUMBAI TECHNO INSTRUMENTS AHEMDABAD ROSSEL





2x500 MW NNTPP, Neyveli
 CONTRACT SPECIFICATION
 STEAM GENERATOR & AUX. PACKAGE - NTA1



SL. NO.	ITEM DESCRIPTION	CATEGORY-I	CATEGORY-II
11.	DISPLACER TYPE LEVEL TRANSMITTER	CHEMTROLS ENGG PVT LTD V-AUTOMATION DRESSER VALVES ECKARDT GERMANY DRESSER MASONIELAN, FRANCE. / DRESSER VALVES INDIA LTD, COIMBATORE CHEMTROLS, MUMBAI (ECKARDT, GERMANY) ECKARDT, GERMANY	LEVCON INSTRUMENTS PVT LTD PUNE TECHTROL PVT LTD SBEM ABB SIEMENS DK INSTRUMENTS MIL CONTROLS LIMITED, KERALA
12.	ULTRASONIC LEVEL TRANSMITTER	E&H EMERSON VEGA, GERMANY SIEMENS, CANADA ABB KROHNE EMERSON PROCESS ENDRESS+HAUSER, GERMANY/INDIA SIEMENS MILTRONICS, CANADA	TOSHBRO, INDIA
13.	RADAR TYPE LEVEL TRANSMITTER	EMERSON E&H SIEMENS, CANADA EMERSON PROCESS ENDRESS+HAUSER, GERMANY / INDIA HONEYWELL, USA / PUNE KROHNE, FRANCE K-TEK, USA MAGNETROL, BELGIUM VEGA, GERMANY	TOSHBRO, INDIA MAGNETROL LEVCON ABB
14.	RF TYPE LEVEL SWITCH	E&H LEVCON LEVCON INSTRUMENTS P LTD, KOLKATA	EMERSON, INDIA SIEMENS, CANADA TOSHBRO, INDIA MAGNETROL EPT CHEMTROL CHEMTROLS SAMIL, MUMBAI DK INSTRUMENTS, KOLKATA S.B.ELECTRO-MECHANICALS PVT LTD, PUNE SIGMA INSTRUMENTS COMPANY, MUMBAI
15.	CORIOLIS FLOW METER	ENDRESS+HAUSER, INDIA EMERSON PROCESS MANAGEMENT, INDIA YOKOGAWA	HEINRICHS MESSTECHNIK GMBH, GERMANY FORBES MARSHAL SIEMENS ABB





SL. NO.	ITEM DESCRIPTION	CATEGORY-I	CATEGORY-II
			INTERNATIONAL NETHERLANDS UNIFLEX CABLES LIMITED VALSAD
22.	INSTRUMENT SIGNAL CABLE	CORDS CABLES.,RAJASTHAN TCL KEI POLYCAB THERMO CABLES DELTON CORDS CABLES, RAJASTHAN DELTON CABLES, FARIDABAD INCAB, PUNE KEI INDUSTRIES LTD, CHENNAI PARAMOUNT CABLES, ALWAR POLYCAB, DAMAN THERMO CABLES, HYDERABAD	TC COMMUNICATION ADVANCE CABLES TECHNOLOGIES, BANGALORE GOYOLENE FIBRES ,MUMBAI KERPEN CABLES,GERMANY - TC COMMUNICATION. DELHI GUPTA POWER INFRASTRUCTURE, BHUBANESHWAR SUYOG ELECTRICALS, BARODA MANSFIELD CABLE , NOIDA ASSOCIATED CABLES PVT LTD MUMBAI BICC CABLES LIMITED.UK BRIMSON CABLES PVT.LTD.DELHI ELKAY TELELINKS LIMITED FARIDABAD GEMSCAB INDUSTRIES LTD.ALWAR GOVIND CABLE INDUSTRIES KOLKATA KEC INTERNATIONAL LIMITED CHENNAI LEONI KERPEN GMBH CHENNAI RADIANT- RSCC SPECIALTY CABLES PVT. HYDERABAD SARK CABLES PVT.LTD. PALAKKAD SERVEL UDYOG (P) LTD. FARIDABAD SCOT INNOVATION WIRES & CABLES NEW DELHI THERMO ELECTRIC INTERNATIONAAL NETHERLANDS UNIFLEX CABLES LIMITED VALSAD
23.	FIBER OPTIC CABLE	BIRLA ERICSON OPTICAL LIMITED VINDHYA TELELINKS	STERLITE TECHNOLOGIES LTD UM CABLES LTD INDIA BOSNET
24.	FURNACE FLAME VIEWING SYSTEM	DURAG DIAMOND POWER SWEDEN AB	TECHFAB HI TECH LUCENT MARCONI MIRION TECHNOLOGIES (IST) LTD.UK TLT ENGG.INDIA PVT.LTD.





2x500 MW NNTPP, Neyveli
CONTRACT SPECIFICATION
STEAM GENERATOR & AUX. PACKAGE - NTA1



SL. NO.	ITEM DESCRIPTION	CATEGORY-I	CATEGORY-II
			KOLKATA TOSHNIWAL INDUSTRIES PVT.LTD.RAJASTHAN
25.	ELECTRONIC DRUM LEVEL INDICATOR	NARVIK-YARWAY B.V YARWAY CORPORATION	EMERSON FOSSIL
26.	FLAME SCANNER/ FLAME MONITORING SYSTEM	DURAG,GERMANY FIRE EYE,UK COEN BHARATH	ABB HONEYWELL INDIA CRESCENT CUMBUSTON SYSTEM FORNEY
27.	ACOUSTIC PYROMETER	SEI-GERMANY	BONNEN BERG & DRESCHER ENERTECHNIX US
B.	Class- II Equipments		
1.	JUNCTION BOX	BALIGA LIGHT INSTRUMENTS LTD, INDIA FCG FLAME PROOF CONTROLS, INDIA BALIGA LIGHTING, CHENNAI DEVI POLYMERS, CHENNAI. PYROTECH, UDAIPUR SAJAS ELECTRICALS, India	FLAME PROOF EQUIPMENT, INDIA ROBOTIC INSTRUMENT KS INSTRUMENTS KHODAY CONTROL SYSTEM FICOM ENGG. PVT. LTD, BANGALORE K.S. INSTRUMENTS, BANGALORE. MANISHA ENTERPRISES, PUNE SUCHITRA INDUSTRIES, BANGALORE. CHEMIN CONTROLS, PONIDCHERRY ELECTRO MECHANICAL (INDIA),KOLKATA BALAJI ELECTRO CONTROLS PVT.LTD. BANGALORE PRAMMEN, PUDDOKOTTAI VENKAT ELECTRONICS TRICHY VRL AUTOMATION ENGINEERING & PROJEC BANGALORE
2.	LIE/LIR	CHEMIN CONTROLS PYROTECH CHEMIN CONTROLS, PONIDCHERRY FORBES MARSHAL, PUNE INSTRUMENTATION LIMITED, KOTA PRAMMEN INDUSTRIES PYROTECH, UDAIPUR PYROTECH ELECTRONICS P.LTD	PRESIDENT ROBOT INSTRUMENTS INDIA CONTROLS & SWITCHGEARS ECIL ILK SAJAS ELECTRICALS SYSPRO AUTOMATION PROCON, CHENNAI





SL. NO.	ITEM DESCRIPTION	CATEGORY-I	CATEGORY-II
9.	SPEED TRANSMITTER / SWITCH	P&F HONEYWELL INDIA	
10.	PRESSURE GAUGE/DRAFT GAUGE	GENERAL INSTRUMENTS CONSORTIUM IND. AN INSTRUMENTS PVT. LTD., INDIA WIKA INSTRUMENTS, INDIA WAREE H GURU A N INSTRUMENTS PVT LTD, KOLKOTTA, ASHCROFT INDIA (earlier PRECISION INDUSTRIES, AHMADABAD) FORBES MARSHALL LTD, HYDERABAD GENERAL INSTRUMENTS CONSORTIUM, GOA/MUMBAI GOA THERMOSTATIC INSTRUMENTS, GOA H.GURU INSTRUMENTS MANOMETER, MUMBAI WAAREE INDUSTRIES, MUMBAI WIKA, INDIA BUDENBERG GAUGE CO LTD.UK MANOMETER (INDIA) PVT.LTD., India WIKA INSTRUMENTS INDIA PVT.LTD, India	TRAFAG INDIA, INDIA ITT BOURDON PYROELECTRONICS GLUCK, MUMBAI ODIN, AHMADABAD / CHENNAI WALCHAND INDUSTRIES LTD., DHARWAD BAUMER TECHNOLOGIES INDIA PVT.LTD VAPI WIKA ALEXANDER WIEGAND GMBH & CO., Germany
11.	DP GAUGE	GENERAL INSTRUMENTS CONSORTIUM AN INSTRUMENTS PVT. LTD., INDIA WIKA INSTRUMENTS, INDIA WAREE H GURU A.N.INSTRUMENTS PVT. LIMITED KOLKATA H GURU INSTRUMENTS (SI) P.LTD. BANGALORE GENERAL INSTRUMENTS CONSORTIUM MUMBAI SWITZER INSTRUMENT LTD. CHENNAI WIKA INSTRUMENTS INDIA PVT.LTD PUNE	TRAFAG INDIA, INDIA ITT BOURDON





SL. NO.	ITEM DESCRIPTION	CATEGORY-I	CATEGORY-II
12.	TEMPERATURE GAUGE	TRAFAG INDIA, INDIA GENERAL INSTRUMENTS CONSORTIUM IND. PYROELECTRIC INSTRUMENTS GOA PVT. LTD AN INSTRUMENTS PVT. LTD., INDIA WIKA INSTRUMENTS, INDIA WAREE H GURU A N INSTRUMENTS PVT LTD, KOLKOTTA, ASHCROFT INDIA FORBES MARSHALL, HYDERABAD GENERAL INSTRUMENTS CONSORTIUM, GOA/MUMBAI GOA THERMOSTATIC INSTRUMENTS, GOA H.GURU INSTRUMENS WAREE,DADRA WIKA, INDIA SWITZER INSTRUMENT LTD. CHENNAI PYRO ELECTRIC INSTRUMENTS GOA P LTD	BAUMER TECHNOLOGIES INDIA PVT.LTD, VAPI BUDENBERG GAUGE CO LTD.,UK GOA INSTRUMENT INDUSTRIES PVT LTD
13.	PRESSURE SWITCH	SWITZER INDIA PVT LTD GIC WIKA TRAFAG INDIA, INDIA INDFOSS ASHCROFT INDIA GIC MUMBAI INDFOS INDUSTRIES LTD, GAZIABAD SOR INC, USA SWITZER INSTRUMENT CO, CHENNAI TRAFAG-INDIA, RANIPET WAREE, VAPI SOR EUROPE LIMITED ENGLAND DAG PROCESS INSTRUMENTS GENERAL INSTRUMENTS CONSORTIUM SWITZER INSTRUMENT LTD VASU TECH LIMITED	WAREE UNITED ELECTRIC REGULATEURS GEORGIN FRANCE ALLEN BRADLEY BAUMER TECHNOLOGIES INDIA PVT.LTD, DELTA CONTROLS LIMITED, UK KDG INSTRUMENTS LTD., UK WIKA ALEXANDER WIEGAND GMBH & CO., Germany
14.	DP SWITCH	SWITZER INDIA PVT LTD TRAFAG INDIA, INDIA GENERAL INSTRUMENTS CONSORTIUM MUMBAI	GIC PYRO ELECTRIC UNITED ELECTRIC REGULATEURS GEORGIN FRANCE





SL. NO.	ITEM DESCRIPTION	CATEGORY-I	CATEGORY-II
		SOR EUROPE LIMITED ENGLAND SWITZER INSTRUMENT LTD.,CHENNAI INDFOS INDUSTRIES LTD., CHENNAI SOR INC , USA	BAUMER TECHNOLOGIES INDIA PVT.LTD
15.	CONDUCTIVITY TYPE LEVEL SWITCH	LEVCON INSTRUMENTS PVT LTD PUNE TECHTROL PVT LTD CHEMTROLS ENGG PVT LTD LEVELSTATE SOLARTON LEVELSTATE, UK / HI-TECH, KOLKATA SOLARTON / MOBREY, UK / RAMAN INSTRUMENTS, MUMBAI YARWAY CORPORATION,USA	SIEMENS,CANADA/TOSHBRO,IND IA MOBREY LTD.,UK HI-TECH SYSTEM&SERVICES LTD, India
16.	CAPACITANCE TYPE LEVEL SWITCH	LEVCON INSTRUMENTS PVT LTD CHEMTROLS ENGG PVT LTD DK INSRTUMENTS, KOLKATA LEVCON INSTRUMENTS P LTD, KOLKATA S.B.ELECTRO-MECHANICALS PVT LTD, PUNE V.AUTOMAT&INSTRUMENTS PVT LTD,INDIA	PUNE TECHTROL PVT LTD SIEMENS
17.	FLOAT / DISPLACER TYPE LEVEL SWITCH	LEVCON INSTRUMENTS PVT LTD CHEMTROLS ENGG PVT LTD SBEM CHEMTROLS SAMIL, MUMBAI DK INSRTUMENTS, KOLKATA LEVCON INSTRUMENTS P LTD, KOLKATA S.B.ELECTRO-MECHANICALS PVT LTD, PUNE CHEMTROLS SAMIL (INDIA) P.LTD D.K.INSTRUMENTS PVT. LTD	PUNE TECHTROL PVT LTD SIGMA INSTRUMENTS COMPANY, MUMBAI ASIAN INDUSTRIAL VALVES AND INSTRUM GENERAL INSTRUMENTS CONSORTIUM TRANSDUCER & CONTROLS PVT LTD V.AUTOMAT & INSTRUMENTS P.LTD
18.	SMART POSITIONERS	SIEMENS ABB DRESSER INSTRUMENTATION LTD. KERELA	METSO AUTOMATION FISHER SAMSON ILP CCI KELTRON CONTROLS AROOR R.G.S.ELECTRO-PNEUMATICS LTD UK





SL. NO.	ITEM DESCRIPTION	CATEGORY-I	CATEGORY-II
19.	AIR FILTER REGULATOR	SHAVO NORGREN (I) PVT LTD., INDIA PLACKA JRU INSTRUMENTS, CHENNAI SHAVO NORGREN VELJAN HYDRAIR JRU INSTRUMENTS (formerly PLACKA), CHENNAI	FISHER,INDIA
20.	LIMIT SWITCH	HONEYWELL INDIA JAI BALAJI, CHENNAI BHARATIYA CUTLER AND HAMMER, FARIDABAD	OMRON,INDIA
21.	SOLENOID VALVES	ASCO ROTEX AUTOMATION INDIA AVCON CONTROLS, MUMBAI NORGREN,INDIA ASCO NUMATICS (INDIA) PRIVATE LTD. CHENNAI IMI NORGREN HERION PVT.LTD NOIDA ROTEX AUTOMATION LIMITED VADODRA U.V.INTERNATIONAL CHENNAI	VELJAN HYDRAIR, HYDERABAD JEFFERSON,UK ESCO COMP AIR SYSTEMS (REGD) MUMBAI NUCON INDUSTRIES PVT.LTD. HYDERABAD VKE VALVES INDUSTRIES P.LTD. MUMBAI
22.	FLOW SWITCH	SWITZER GENERAL INSTRUMENTS CONSORTIUM, GOA/MUMBAI KROHNE MARSHALL PUNE SWITZER INSTRUMENT CO, CHENNAI	

10.5 List of Sub-Vendors - Civil & Structural Supply Portion
a. Building Materials

SL. NO.	ITEM DESCRIPTION	CATEGORY-I	CATEGORY-II
1.	FLUSH DOORS	Kutty flush doors & Furniture Co. Pvt. Ltd Shakti Met-Dor Ltd Greenply Industries Ltd., National Plywood Industries Pvt. Ltd. Kitply	Diamond Flush Doors Vidarbha Veneer Industries Wood Crafts- Pondicherry Western India Plywood Godavari Plywood Art Plywood P J Timbers & Ply (Niki Door).
2.	PLYWOOD PRODUCTS PARTICLE BOARDS	Novapan Particle Boards Kitply	IPM Bhutan Boards





**TECHNICAL SPECIFICATION FOR
COMPRESSED AIR SYSTEM
2 X 500 MW, NNTPS, NEYVELI**

SPEC NO. PE-TS-400-555-A001

VOLUME-III

ANNEXURE - III

REV.NO. 0

**ANNEXURE - III
AUXILIARY POWER CONSUMPTION**

2 X 500MW NNTPS, NEYVELI						
Auxiliary Power Consumption For Air Compressor System Shall be as per Following :						
S.No. (1)	Description of Equipments (2)	Nos. of Equipments (3)		Total Auxiliary Power Consumption for Each Equipment at Motor Input Terminals & control Panel (4)	Duty Factor (5)	Total (KW) (6) = (3A)*(4)*(5)
		Working (3A)	Standby (3B)			
1	Serve Air Compressor (Oil free Screw type) 36 NM3/min at 9.0 Kg/cm2 (g) pressure	1	1		1	
2	Instrument Air Compressor (Oil free Screw type) 36 NM3/min at 9.0 Kg/cm2 (g)	2	1		1	
3	Air Drying Plant Unit (Conventional Twin Tower type/ Rotary drun type as applicable)	2	1		1	
					TOTAL	1100

Note :

1	Estimated Power Consumption Figure for the compressed air system (For Working Drives Only) considered is 1100 KW (For station)
2	Bidders Auxiliary power consumption at motor input terminals (Not Shaft Power) including power for control panel as furnished above shall be demonstrated by the successful bidder during performance testing of compressors & dryers at works/site.
.	
.	



**TECHNICAL SPECIFICATION FOR
COMPRESSED AIR SYSTEM**
2 X 500 MW, NNTPS, NEYVELI

SPEC NO. PE-TS-400-555-A001

VOLUME-III

ANNEXURE - IV

REV.NO. 0

ANNEXURE - IV
ELECTRICAL LOAD LIST

ELECTRICAL FEEDER LIST		CUSTOMER: NLC					JOB No.: 400		Doc No. PE-TS-400-555-E001 Rev 00	
		JOB: 2 x 500 MW NNTPS, NEYVELI					SI.No.: 555		DATE: 28-08-14	
		SYSTEM: COMPRESSED AIR SYSTEM					CONTI/NTT		LOAD CODE	
S No	TITLE	LOCATION	UNIT No	NAME PLATE KW	NO OF WORKING	NO OF STANDBY	VOLTAGE CODE	REMARKS		
1	IA COMPRESSOR	Comp House		355	2	1	B			U
2	IA COMPRESSOR PANEL	Comp House		5	2	1	D			S
3	SA COMPRESSOR	Comp House		355	1	1	B			U
4	SA COMPRESSOR PANEL	Comp House		5	1	1	D			U
5	Air Drying Plant for IA System	Comp House		6	2	1	D			S
6	Auto Drain Traps for Air Recievers	Comp House		0.25	7	0	E			S
7	Motorized gate valve	Comp House		1	6	0	D			B
										no. shall be as per the PID requirement

VOLTAGE CODE: (AC), A=11KV, B=6.6KV, C=3.3KV, D=415V, E=240V (1 Ph), F= 110 (DC) G=220V, H= 110V, K=+24V, L=-24V

LOAD CODE: U= Unidirectional Starter, B= Bidirectional Starter S= Supply Feeder

Note:

- 1 Bidder to confirm that the system provided by them would be catered by the above loads considered by BHEL. In case there is any variation, the same should be clearly stated in the technical offer. No changes would be admissible during detailed engineering stage.
- 2 Bidder to note that for the system being supplied by them, only the above loads will be provided. In case any other load is required the same would be derived / multiplied by bidder on their own from these feeders only.



**NNTPP, NEYVELI
(2 X 500 MW)**

SPECIFICATION No: PE-TS-400-555-A001

CUSTOMER NLC

VOLUME - III ANNEXURE - V

REV 00

ANNEXURE - V
MASTER DWG. LIST FOR CAS
&
REFERENCE DRAWINGS

	NNTPP, NEYVELI (2 X 500 MW) MASTER DRAWING LIST	SPECIFICATION No: PE-TS-400-555-A001	
		CUSTOMER	NLC
		VOLUME - III	ANNEXURE - V
		REV	00

1	GA Drawings for Instrument and Service Air Compressors	PE-V0-400-555-A301	4 weeks from the date of LOI
2	GA Drawing for Air Drying Plant	PE-V0-400-555-A302	4 weeks from the date of LOI
3	GA drawing for Air receiver	PE-V0-400-555-A303	4 weeks from the date of LOI
4	GA drawing for Motor	PE-V0-400-555-A304	4 weeks from the date of LOI
5	Compressor House Layout	PE-V0-400-555-A401	4 weeks from the date of LOI
6	P&ID for Compressed air system inside COMPRESSOR HOUSE	PE-V0-400-555-A501	4 weeks from the date of LOI
7	P & ID for Instrument and Service air Compressors	PE-V0-400-555-A502	4 weeks from the date of LOI
8	P & ID for Air Dryer	PE-V0-400-555-A503	4 weeks from the date of LOI
9	Operation & Control Philosophy of compressed Air System	PE-V0-400-555-A701	6 weeks from the date of LOI
10	Electrical & Internal Wiring Diagram for Compressor Panel	PE-V0-400-555-A901	4 weeks from the date of LOI
11	Control Cable Schedule & interconnection diagram	PE-V0-400-555-A902	8 weeks from the date of LOI
12	TDS for instrument air and service air compressors	PE-V0-400-555-A201	4 weeks from the date of LOI
13	TDS for air drying plant	PE-V0-400-555-A202	4 weeks from the date of LOI
14	TDS & Characteristic Curves of Motor for Air Compressor	PE-V0-400-555-A203	4 weeks from the date of LOI
15	TDS for Valves	PE-V0-400-555-A204	6 weeks from the date of LOI
16	TDS for Instruments	PE-V0-400-555-A205	6 weeks from the date of LOI
17	Sizing calculation of air receiver	PE-V0-400-555-A206	4 weeks from the date of LOI
18	Quality Plan of Air Compressor	PE-V0-400-555-A101	4 weeks from the date of LOI
19	Quality Plan for Air Drying plant	PE-V0-400-555-A102	4 weeks from the date of LOI
20	Quality Plan for Motor	PE-V0-400-555-A103	4 weeks from the date of LOI
21	Quality Plan for Air Receiver	PE-V0-400-555-A104	4 weeks from the date of LOI
22	Quality Plan for Valves	PE-V0-400-555-A105	6 weeks from the date of LOI
23	Quality Plan for Instruments	PE-V0-400-555-A106	6 weeks from the date of LOI
24	Electrical feeder list	PE-V0-400-555-E001	4 weeks from the date of LOI
25	CONTROL SCHEME/LOGIC DIAGRAM (TO BE IMPLEMENTED IN DCS)	PE-V0-400-555-I001	6 weeks from the date of LOI
26	Demonstration test for Compressed air system	PE-V0-400-555-A702	8 weeks from the date of LOI
27	O & M Manual for Compressed air system.	PE-V0-400-555-A801	10 weeks from the date of LOI

NOTES:

1. ANY OTHER DOCUMENT DECIDED DURING DETAILED ENGINEERING SHALL BE PROVIDED BY BIDDER WITHOUT ANY COMMERCIAL/TECHNICAL IMPLICATION.

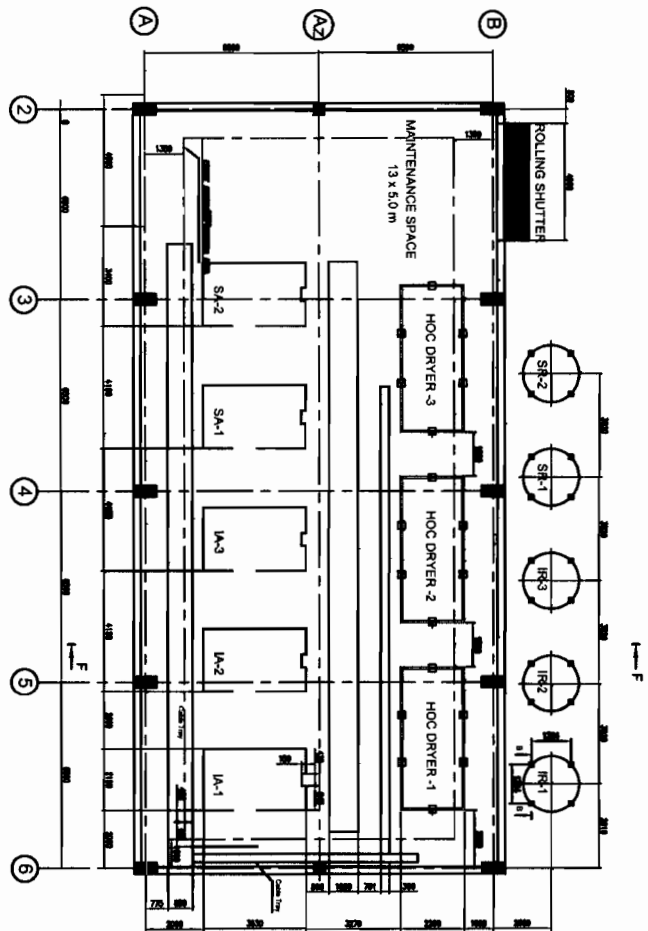

PLAN

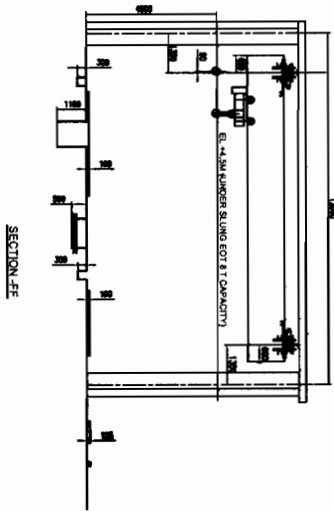

NOTES:
 01) REFER TO COMPAN THE COMPRESSOR HOUSE SPACE IS SUFFICIENT TO HOUSE THE EQUIPMENTS.
 02) THE DIMENSIONS INDICATED FOR COMP HOUSE ARE FOR THE EQUIPMENTS SPECIFIC.
 03) REFER TO THE ORIGINAL DIMENSIONS OF THE BLIND BY PWD'S REPORT TO COMPAN THE SPACE.

LABORATORY INSTRUMENTATION	
NO.	DESCRIPTION
01	TEMPERATURE
02	PRESSURE
03	FLOW
04	LEVEL
05	PH
06	CONDUCTIVITY
07	DENSITY
08	REFRACTIVE INDEX
09	DISPERSION
10	BIREFRINGENCE
11	OPTICAL ACTIVITY
12	MAGNETIC SUSCEPTIBILITY
13	PERMEABILITY
14	INDUCTIVE CAPACITANCE
15	DIELECTRIC CONSTANT
16	LOSS TANGENT
17	IMPEDANCE
18	REFLECTANCE
19	TRANSMITTANCE
20	SCATTERING
21	DIFFRACTION
22	INTERFERENCE
23	COHERENCE
24	POLARIZATION
25	BIREFRINGENCE
26	OPTICAL ACTIVITY
27	MAGNETIC SUSCEPTIBILITY
28	PERMEABILITY
29	INDUCTIVE CAPACITANCE
30	DIELECTRIC CONSTANT
31	LOSS TANGENT
32	IMPEDANCE
33	REFLECTANCE
34	TRANSMITTANCE
35	SCATTERING
36	DIFFRACTION
37	INTERFERENCE
38	COHERENCE
39	POLARIZATION
40	BIREFRINGENCE
41	OPTICAL ACTIVITY
42	MAGNETIC SUSCEPTIBILITY
43	PERMEABILITY
44	INDUCTIVE CAPACITANCE
45	DIELECTRIC CONSTANT
46	LOSS TANGENT
47	IMPEDANCE
48	REFLECTANCE
49	TRANSMITTANCE
50	SCATTERING
51	DIFFRACTION
52	INTERFERENCE
53	COHERENCE
54	POLARIZATION
55	BIREFRINGENCE
56	OPTICAL ACTIVITY
57	MAGNETIC SUSCEPTIBILITY
58	PERMEABILITY
59	INDUCTIVE CAPACITANCE
60	DIELECTRIC CONSTANT
61	LOSS TANGENT
62	IMPEDANCE
63	REFLECTANCE
64	TRANSMITTANCE
65	SCATTERING
66	DIFFRACTION
67	INTERFERENCE
68	COHERENCE
69	POLARIZATION
70	BIREFRINGENCE
71	OPTICAL ACTIVITY
72	MAGNETIC SUSCEPTIBILITY
73	PERMEABILITY
74	INDUCTIVE CAPACITANCE
75	DIELECTRIC CONSTANT
76	LOSS TANGENT
77	IMPEDANCE
78	REFLECTANCE
79	TRANSMITTANCE
80	SCATTERING
81	DIFFRACTION
82	INTERFERENCE
83	COHERENCE
84	POLARIZATION
85	BIREFRINGENCE
86	OPTICAL ACTIVITY
87	MAGNETIC SUSCEPTIBILITY
88	PERMEABILITY
89	INDUCTIVE CAPACITANCE
90	DIELECTRIC CONSTANT
91	LOSS TANGENT
92	IMPEDANCE
93	REFLECTANCE
94	TRANSMITTANCE
95	SCATTERING
96	DIFFRACTION
97	INTERFERENCE
98	COHERENCE
99	POLARIZATION
100	BIREFRINGENCE

15



**TECHNICAL SPECIFICATION FOR
COMPRESSED AIR SYSTEM
2 X 500 MW, NNTPS, NEYVELI**

SPEC NO. PE-TS-400-555-A001	
VOLUME-III	
ANNEXURE - VI	
REV.NO.	0

ANNEXURE - VI
**LIST OF SPECIAL MAINTENANCE TOOLS &
TACKLES**



**TECHNICAL SPECIFICATION FOR
COMPRESSED AIR SYSTEM
2 X 500 MW NNTPS, NEYVELI**

SPEC NO. PE-TS-400-555-A001

VOLUME-III

ANNEXURE - VII

REV.NO. 0

ANNEXURE - VII

LIST OF COMMISSIONING SPARES



**TECHNICAL SPECIFICATION FOR
COMPRESSED AIR SYSTEM
2 X 500 MW NNTPS, NEYVELI**

SPEC NO. PE-TS-400-555-A001

VOLUME-III

ANNEXURE - VIII

REV.NO. 0

ANNEXURE - VIII
LIST OF MANDATORY SPARES



LAHMEYER
INTERNATIONAL
INDIA

2x500 MW, NNTPP, Neyveli
CONTRACT SPECIFICATION
STEAM GENERATOR & AUX. PACKAGE - NTA1



Sl. No.	Clause No.	Item Description	Quantity as per Tender	BHEL Remarks	Quantity ordered for 2units by NLC	Supplying Unit	Final Status
472	xiii)	HP dosing pump assembly	1 no.			Deleted from Tender Specifications Vide NLC's Lr Dated 14.08.13	Not ordered
473	1.2.27	Scanner (Cooling air fans)				ALSTOM	
474	i)	Filter screens for cooling air fans	1 no		1 no	ALSTOM	Ordered
475	ii)	Fan impeller	1 no		1 no	ALSTOM	Ordered
476	iii)	Motor-AG	1 no		1 no	ALSTOM	Ordered
477	iv)	Seal	2 nos. of each type		2 nos. of each type	ALSTOM	Ordered
478	v)	Bearings	1 no. of each type		1 no. of each type	ALSTOM	Ordered
479	1.2.28	Power cycle piping				VALVES	
480	i)	Spare gasket for all the gate valves of sizes 15mm NB to 500mm NB	5% of each type & size per unit		5% of each type & size per unit	VALVES	Ordered
481	ii)	Spare set of gland packings of all the gate valves for all sizes	5% of each type & size per unit		5% of each type & size per unit	VALVES	Ordered
482	iii)	Spare gasket for all the globe valves for sizes 15mm NB to 500 mm NB	5% of each type & size per unit		5% of each type & size per unit	VALVES	Ordered
483	iv)	Spare set of gland packings of all the globe valves for all sizes	5% of each type & size per unit		5% of each type & size per unit	VALVES	Ordered
484	v)	Spare gaskets for NRV for all the valves	5% of each type & size per unit		5% of each type & size per unit	VALVES	Ordered

SG Vol-VI, Sec-1, Mandatory Spares, Tools & Tackles - Mechanical. - NTA1

Page 40

042





Sl. No.	Clause No.	Item Description	Quantity as per Tender	BHEL Remarks	Quantity ordered for 2units by NLC	Supplying Unit	Final Status
485	vi)	Spare set of gaskets for safety relief valves for all sizes	5% of each type & size per unit		5% of each type & size per unit	VALVES	Ordered
486	vii)	Complete gate valves assembly upto the size of 50NB	1 no. of each type	Not anticipated	1 no. of each type	VALVES	Not applicable
487	viii)	Complete angle valves upto the size of 50 NB	1 no. of each type	Not-anticipated	1 no. of each type	VALVES	Not applicable
488	ix)	Complete globe valves upto the size of 50 NB	1 no. of each type		1 no. of each type	VALVES	Ordered
489	x)	Complete NRV's upto the size of 50 NB	1 no. of each type		1 no. of each type	VALVES	Ordered
490	xi)	Complete needle valves upto the size of 50 NB	1 no. of each type		1 no. of each type	VALVES	Ordered
491	xii)	Spring hangers	5% of each type & stiffness of quality		5% of each type & stiffness of quality	PC	Ordered
492	xiii)	Gasket for each flanged connection on HP steam and feed line, jacking oil lines	2 nos.		2 nos.	TRY	Ordered
493	xiv)	Steam traps and Y-strainers for each size, type and rating	10% of total population		10% of total population	PC	Ordered
494	xv)	SH spray valve (control)	1no.		1no.	TRY	Ordered
495	xvi)	RH spray valve (control)	1no.		1no.	TRY	Ordered





LAHMEYER
INTERNATIONAL
INDIA

2x500 MW, NNTPP, Neyveli
CONTRACT SPECIFICATION
STEAM GENERATOR & AUX. PACKAGE - NTA1



Sl. No.	Clause No.	Item Description	Quantity as per Tender	BHEL Remarks	Quantity ordered for 2units by MLC	Supplying Unit	Final Status
496	xvii)	Other valves	1 no.		1 no.	VALVES + PC	Ordered
497		* Each type, size & class 100mm below	1 no.		1 no.	VALVES + PC	Ordered
498		* Each type, size & class 100mm above	10% or 2nos. whichever is lesser		10% or 2nos. whichever is lesser	VALVES + PC	Ordered
499	xviii)	Critical piping				PC	
500		For MS, HRH, CRH, BFD, HP-LP Bypass, Aux PRDS systems, spray water and all miscellaneous piping including drains (of boiler scope as follows:				PC	Ordered
501	(a)	* Pipes of dimension 100 Nb and above with IBR certification in form IIIA	6 meters		6 meters	PC	Ordered
502	(b)	* Pipes of dimension below 100 Nb with IBR certification in form IIIB	6 meters		6 meters	PC	Ordered
503	e	* Gaskets for the system including all types of metal gaskets, grafoil	10%		10%	TRY	Ordered
504	1.2.29	Auxiliary Boiler				TRY	
505	i)	Water-wall tubes	5% of population of all sizes and types		2.5% of population of all sizes and types	TRY	Ordered
506	ii)	Super-heater tubes	10% of population		5% of population	TRY	Ordered
507	iii)	Economiser	10% of population	Not applicable	10% of population	TRY	Not applicable
508	iv)	BFP - Pump bearing	1 set		1 set	PC	Ordered
509	v)	BFP - Motor bearing	1 set		1 set	PC	Ordered





LAHMEYER
INTERNATIONAL
INDIA

2x500 MW, NNTPP, Neyveli
CONTRACT SPECIFICATION
STEAM GENERATOR & AUX. PACKAGE - NTA1



Sl. No.	Clause No.	Item Description	Quantity as per Tender	BHEL Remarks	Quantity ordered for 2units by NLC	Supplying Unit	Final Status
510	vi)	FD fan- fan-bearing	1 set		1 set	RPT	Ordered
511	vii)	FD fan- motor bearing	1 set		1 set	RPT	Ordered
512	viii)	Actuator motors	1 no. of each type		1 no. of each type	TRY + RPT	Ordered
513	ix)	Valves	10% of population		5% of population	TRY + VALVES + PC	Ordered
514	x)	Power and control fuse	10% of installed capacity		10% of installed capacity	TRY	Ordered
515	xi)	Oil gun with diffuser	1 set		1 set	TRY	Ordered
516	xii)	Oil hose-pipe	2 sets		2 sets	TRY	Ordered
517	xiii)	Oil gun tips	1 set		1 set	TRY	Ordered
518	xiv)	HEA igniter	1 set		1 set	TRY	Ordered
519	xv)	HP dosing pump bearing	1 set		1 set	PC	Ordered
520	xvi)	Control valve - (feed water)-spere-steam, disc, body seat ring	1 no. each		1 no. each	PC	Ordered
521	xvii)	Control valve - (steam) spere-steam, disc, body seat ring	1 no. each		1 no. each	TRY + PC	Ordered
522	xviii)	Oil system solenoid valve	10% of population		10% of population	TRY	Ordered
523	1.2.30	Compressed air system				PEM	Ordered
524		Screw compressor (instrument air & service air)				PEM	Ordered
525	a)	HP stage				PEM	Ordered
526	i	* High pressure element	1 set of each type/rating		1 set of each type/rating	PEM	Ordered
527	ii	* Bearing for male and female rotors (drive unit)	1 set of each type/rating		1 set of each type/rating	PEM	Ordered



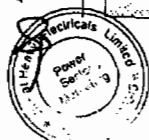

Sl. No.	Clause No.	Item Description	Quantity as per Tender	BHEL Remarks	Quantity ordered for 2units by NLC	Supplying Unit	Final Status
528	iii	* Bearing for male and female rotors (non drive unit)	1 set of each type/rating		1 set of each type/rating	PEM	Ordered
529		* Timing gears	1 set of each type/rating		1 set of each type/rating	PEM	Ordered
530	iv)	* Graphic ring shaft for compressor chamber seals and white metal labyrinth seal	1 set of each type/rating		1 set of each type/rating	PEM	Ordered
531	v	* Suction valve	1 set of each type/rating		1 set of each type/rating	PEM	Ordered
532	vi	* Discharge valve	1 set of each type/rating		1 set of each type/rating	PEM	Ordered
533	vii	* Packing set	1 set of each type/rating		1 set of each type/rating	PEM	Ordered
534	viii	* Axial thrust bearing	1 set of each type/rating		1 set of each type/rating	PEM	Ordered
535	ix)	* Labyrinth oil seal or radial seal or double acting seal for drive shaft	1 set of each type/rating		1 set of each type/rating	PEM	Ordered
536	b)	LP stage				PEM	Ordered
537	i.	* Low pressure element	1 set of each type/rating		1 set of each type/rating	PEM	Ordered
538	ii	* Bearing for male and female rotors (drive end)	1 set of each type/rating		1 set of each type/rating	PEM	Ordered
539	iii	* Bearing for male and female rotors (non drive end)	1 set of each type/rating		1 set of each type/rating	PEM	Ordered
540	iv	* Timing gears	1 set of each type/rating		1 set of each type/rating	PEM	Ordered





LAHMEYER INTERNATIONAL INDIA

**2x500 MW, NNTPP, Neyveli
CONTRACT SPECIFICATION
STEAM GENERATOR & AUX. PACKAGE - NTA1**



Sl. No.	Clause No.	Item Description	Quantity as per Tender type/rating	BHEL Remarks	Quantity ordered for 2units by NLC	Supplying Unit	Final Status
541	v	* Graphic ring shaft for compressor chamber or white metal labyrinth seals	1 set of each type/rating		1 set of each type/rating	PEM	Ordered
542	vi	* Labyrinth oil seal or radial seal or double acting seal for drive shaft	1 set of each type/rating		1 set of each type/rating	PEM	Ordered
543	vii	* Suction valve	1 set of each type/rating		1 set of each type/rating	PEM	Ordered
544	viii	* Discharge valve	1 set of each type/rating		1 set of each type/rating	PEM	Ordered
545	ix)	* Axial thrust bearing	1 set of each type/rating		1 set of each type/rating	PEM	Ordered
546	x	* Packing set	1 set of each type/rating		1 set of each type/rating	PEM	Ordered
547	c)	Motor bearings	1 set of each type		1 set of each type	PEM	Ordered
548	d)	LP stage gear & pinion	1 set of each type		1 set of each type	PEM	Ordered
549	e)	HP stage gear & pinion	1 set of each type		1 set of each type	PEM	Ordered
550	f)	fAir intake filter element with gaskets	2 sets of each type		2 sets of each type	PEM	Ordered
551	g)	Oil filter element with gasket & seals	2 sets of each type		2 sets of each type	PEM	Ordered
552	h)	Safety valve springs and gaskets for LP stage	1 set of each type		1 set of each type	PEM	Ordered
553	i)	Safety valve springs and gaskets for HP stage	1 set of each type		1 set of each type	PEM	Ordered



047

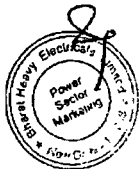

**LAHMEYER
INTERNATIONAL
INDIA**

**2x500 MW, NNTPP, Neyveli
CONTRACT SPECIFICATION
STEAM GENERATOR & AUX. PACKAGE - NTA1**



Sl. No.	Clause No.	Item Description	Quantity as per Tender.	BHEL Remarks	Quantity ordered for 2units by NLC	Supplying Unit	Final Status
554	j)	Valves with actuators (within the compressor house and air drying plant	1 set of each type/rating		1 set of each type/rating	PEM	Ordered
555	k)	Gasket & seals for inter cooler	2 sets		2 sets	PEM	Ordered
556	l)	Gasket & seals for after cooler	2 sets		2 sets	PEM	Ordered
557	m)	Oil Pump/Motor				PEM	Ordered
558	i	* Oil pump and motor complete assembly	1 set		1 set	PEM	Ordered
559	ii	* Pump impeller/ rotor with shaft	1 set		1 set	PEM	Ordered
560	iii	* Set of bearings	2 sets		2 sets	PEM	Ordered
561	iv	* Sets of seals	2 sets		2 sets	PEM	Ordered
562	n)	Drains/Moisture trap	1set of each type/size		1 set of each type/size	PEM	Ordered
563	o)	Gasket and seals for oil cooler	1set of each type/size		1 set of each type/size	PEM	Ordered
564	p)	Air drying plant (ADP) for instrument air system				PEM	Ordered
565	i	* Prefilter element (ceramic candle or as applicable)	1 set		1 set	PEM	Ordered
566	ii	* After filter element (ceramic candle or as applicable)	1 set		1 set	PEM	Ordered
567	iii	* Heater element, if applicable	1 set		1 set	PEM	Ordered





Sl. No.	Clause No.	Item Description	Quantity as per Tender	BHEL Remarks	Quantity ordered for Zunits by NLC	Supplying Unit	Final Status
568	iv	* Heater coil for temperature stabilization (as applicable)	1 set		1 set	PEM	Ordered
569	v	* Bearings	1 set of each type/size		1 set of each type/size	PEM	Ordered
570	q)	Screw compressor motor complete	1 no.		1 no.	PEM	Ordered
571	1.2.31	Elevators	Lot price for 1.2.31.j to 1.2.31.xxxv for applicable items.	(Lot Price for 1.2.31.(i) to 1.2.31.(xxxv)) The list of mandatory spares has been indicated by purchaser and it may so happen that certain equipments or spares may not become applicable due to evolution of design, improvements, obsolescence etc. Furt		TRY + PEM	Not-Ordered
572	ii)	Machine and brake packing unit	1 in each type			TRY + PEM	Not-Ordered
573	iii)	Brake lining with Rivets	1 in each type			TRY + PEM	Not-Ordered
574	iii)	Door-bushings	1 in each type			TRY + PEM	Not-Ordered
575	iv)	Brake-oil	1 in each type			TRY + PEM	Not-Ordered



Mandatory spares of SG & Aux Package (NT A1) of NNTPP ordered now.					
SI No.	Clause No.	ITEM Description	Quantity as per Tender	Ordered Quantity (As per contract)	Balance quantity ordered now (to meet the qty as per Tender)
805	2.3.18	Timers	2 nos. of each type per board	Not Ordered	2 nos. of each type per board
806	2.3.19	Misc. items			
807		i) Push button with contact element	5 nos. of each type		5 nos. of each type
808		ii) Selector switch	5 nos. of each type		5 nos. of each type
809		iii) Voltmeter selector switch	5 nos. of each type	Not Ordered	5 nos. of each type
810		iv) Ammeter selector switch	5 nos. of each type	Not Ordered	5 nos. of each type
811		v) Local remote selector switch	3 nos. of each type	Not Ordered	3 nos. of each type
812		vi) Indicating lamp of LED (LVGP type)	10 nos.	Not Ordered	10 nos.
813		viii) Terminal blocks	10 sets	Not Ordered	10 sets
814		ix) Breaker Test/Service limit switch	5 sets for each type	Not Ordered	5 sets for each type
815		x) Power and control circuit fuses	10 Nos. of each type	Not Ordered	10 Nos. of each type
816		xi) Control Transformer	1 No. each rating	Not Ordered	1 No. each rating
868	2.8	MOTORS (To be repeated for each type & rating)			Ordered now
869	2.8.1	Bearing (driving end)	1 No. of each type		1 No. of each type
870	2.8.2	Bearing (Non-driving end)	1 No. of each type		1 No. of each type
871	2.8.3	End shield (DE and NDE)	1 set of each type		1 set of each type
872	2.8.4	Cooling fan of motors	1 No. of each type		1 No. of each type
873	2.8.5	Fan cover	1 No. of each type		1 No. of each type
874	2.8.6	Lubrication oil pump motor	1 No. of each type and rating		1 No. of each type and rating
875	2.8.7	Bearing puller	1 Nos. of each type		1 Nos. of each type
876	2.8.8	Grease gun	2 Nos.		2 Nos.

Mandatory spares of SG & Aux Package (NT A1) of NNTPP ordered now.					
SI No.	Clause No.	ITEM Description	Quantity as per Tender	Ordered Quantity (As per contract)	Balance quantity ordered now (to meet the qty as per Tender)
877	2.8.9	Special spanners/tools	1 Set		1 Set
884	2.10	ACDB/PDB/LDB/SLDB/AUX. PDB/ DISTRIBUTION PANELS (to be repeated for each type & rating)		Not ordered	Ordered now
885	2.10.1	Busbar support insulators	3 Nos. of each type	Not ordered	3 Nos. of each type
886	2.10.2	MCCB/SFU	2 Nos. of each rating	Not ordered	2 Nos. of each rating
887	2.10.3	MCB	2 Nos. of each rating	Not ordered	2 Nos. of each rating
888	2.10.4	Control switch	2 Nos. of each type	Not ordered	2 Nos. of each type
889	2.11	ILLUMINATION		Not ordered	Ordered now
890	2.11.1	Lamps	10 Nos. of each type	Not Ordered	10 Nos. of each type
891	2.11.2	Fittings	2 Sets of each type	Not Ordered	2 Sets of each type
892	2.11.3	Control gear box complete	5 Sets of each type	Not Ordered	5 Sets of each type
893	2.11.4	Timer/photo cell (wherever applicable)	2 Nos.	Not Ordered	2 Nos.
894	3	SECTION-III MANDATORY SPARES- CONTROL & INSTRUMENTATION			
904	h	Printer Paper	1000 sheets of each type	Not ordered	1000 sheets of each type
995	3.6	Instrumentation cables & Accessories			
996	a	Cables (including compensating cable)	5% of total installed Length (in running meter) of each type, pair & size (if total installed length < 500 mtrs.), 1 no. of 500 mtr. Drum (if total installed length > 500 mtrs.)		5% of total installed Length (in running meter) of each type, pair & size (if total installed length < 500 mtrs.), 1 no. of 500 mtr. Drum (if total installed length > 500 mtrs.)

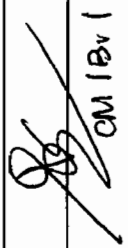
 CM 18v / PSE



**2x500 MW, NNTPP, Neyveli
CONTRACT SPECIFICATION
STEAM GENERATOR & AUX. PACKAGE- NTA1**



Sl No.	Clause No.	Item Description	Quantity as per Tender	BHEL Remarks	Quantity ordered for 2units by NLC	Supplying Unit	Final Status
1007	d	Interface Units/ Communication module	1 no. of each type & Model	quoted	1 no. of each type & Model	TRY + AL STOM	Ordered
1008	e	Interconnecting Cables	1 no. of each type	quoted	1 no. of each type	TRY + AL STOM	Ordered
1009	f	Batteries for RAM battery back-up	1 set of each type	quoted	1 set of each type	TRY + AL STOM	Ordered
1010	3.9	Compressed Air System		Lot price for As applicable items which is included in sl no. 1.2.30		PEM	
1011	a	Complete control unit with display/operating unit	1 no. of each type & Model		1 no. of each type & Model	PEM	Ordered
1012	b	Interface/communication hardware for interfacing with other control systems	1 no. of each type & Model		1 no. of each type & Model	PEM	Ordered





LAHMEYER
INTERNATIONAL
INDIA

2x500 MW, NNTPP, Neyveli
CONTRACT SPECIFICATION
STEAM GENERATOR & AUX. PACKAGE- NTA1



	Local instruments including gauge, switch, transmitter etc.	1 no. of each type, range & model	1 no. of each type, range & model	PEM	Ordered
1013	c				

Note:

- ~~1. The nos. indicated in the M/s BHEL Remarks column is considered as tentative only. The actual quantity will be arrived during detailed engineering.~~
- ~~2. If for any spare item, BHEL units other than the BHEL units indicated against "supplying unit" column are found applicable for that system/equipment during detailed engineering, the item will be supplied by the other applicable units also.~~



093

2





**TECHNICAL SPECIFICATION FOR
COMPRESSED AIR SYSTEM
2 X 500 MW, NNTPS, NEYVELI**

SPEC NO. PE-TS-400-555-A001

VOLUME - III

ANNEXURE - IX

REV.NO. 0

**ANNEXURE - IX
PRE-BID CLARIFICATION FORMAT**



**TECHNICAL SPECIFICATION FOR
COMPRESSED AIR SYSTEM
2 X 660 MW RRVUNL SURATGARH STPP STAGE-V**

SPEC NO. PE-TS-392-555-A001

VOLUME-III

ANNEXURE - X

REV.NO. 0

ANNEXURE - X

SCHEDULE OF DEVIATIONS

(All deviations from the Technical Specification shall be filled in by the BIDDER clause by clause in this schedule)



**TECHNICAL SPECIFICATION FOR
COMPRESSED AIR SYSTEM
2 X 500 MW, NNTPS, NEYVELI**

SPEC NO. PE-TS-400-555-A001

VOLUME-III

ANNEXURE - X

REV.NO. 0

**VOLUME-III
LIST OF DOCUMENTS TO BE SUBMITTED ALONG WITH TENDER**

	TITLE:	SPEC. NO.: PE-TS-400-555-A001
	TECHNICAL SPECIFICATION	VOLUME: III
	2X500 MW, NNTPS, NEYVELI	ANNEXURE - X
	COMPRESSED AIR SYSTEM	REV. NO. 0
		SHEET 1 OF 1

CHECK LIST TO BE SUBMITTED BY BIDDER ALONG WITH THE BID

SI No.	Item Description	Yes/No
1	Schedules submitted dully filled up with bidder's signature and stamp. 1) Technical Deviation Schedule (Annexure - X) 2) List of Special Maintenance Tool & Tackles (Annexure - VI) 3) List of commissioning spares (Annexure - VII) 4) Auxiliary Power Consumption For Compressed Air System (Annexure - III) 5) Compliance and Confirmation certificate (Annexure - I)	
2	Resolution to pre-bid clarification s, if any, duly stamped and signed by the bidder enclosed with the bid	
3	A copy of this sheet " Electrical E quipment Specificat ion for COMPRESSED AI R SYST EM and sheet "Electrical Scope between BHEL and Vendor" with bidder's signature and company stamp.	
4	Un-priced bid- clearly indicating 'QUOTED' and 'NOT-QUOTED' against each item.	
5	'Compressor House Layout (Docu ment no.PE-DG- 400-555-A001) Annexure - V of technical specification' duly stamped and signed by bidder enclosed with the bid.	
6	Electrical load List (Ann exure - IV) of technical sp ecification duly stamped and signed by bidder enclosed with the bid	
7	Supporting Document s meeting PQR req uirements(if Applicable)	
8	Offered model of compressor matching FAD calculat ion along with t he catalogu e of the off ered model to just ify selection.	
9	<ul style="list-style-type: none"> • Earthin g requirement 	

Please note that all the schedules shall be submitted even though they may not be applicable. Under such circumstances it shall be clearly mentioned across such schedules that these are not applicable.(e.g . incase of there are no technical d eviation, it shall be mentioned in the deviation sched ule that ' T HERE ARE NO DEVI ATIONES TO THE TECHNICAL SPECIFICATION').

Name: _____

Signature: _____

Designation: _____

Compan y: _____

Date: _____

	NNTPP, NEYVELI (2 X 500 MW)	SPECIFICATION No: PE-TS-400-555-A001	
		CUSTOMER	NLC
		VOLUME - III	ANNEXURE - XI
		REV	00

ANNEXURE - XI

PRICE FORMAT

PRICE CST

Design, engineering, manufacturing, supply, erection, commissioning etc of Compressed Air System for 2x500MW NNTPP, NEYVELI.

TENDER DOCUMENT NO - PE-TS-400-555-A001

SCH-1 - TOTAL PRICE

SL NO	DESCRIPTION	QUANTITY	TOTAL PRICE (Rs)
1.0	Total lumpsum firm prices for design, manufacturing, inspection and testing at manufacturer's work, proper packing, delivery to site, and erection and commissioning, final painting & carrying out performance tests at site for COMPRESSED AIR SYSTEM as mentioned in the different sections of this specification for 2 X 500 MW NEW NEYVELI TPP.	1 LOT	

PRICE CST									
Design, engineering, manufacturing, supply, erection, commissioning etc of Compressed Air System for 2x500MW NNTPP, NEYVELI.									
TENDER DOCUMENT NO - PE-TS-400-555-A001									
SCH-2 - TOTAL PRICE BREAK-UP									
SL NO	DESCRIPTION	QUANTITY	TOTAL PRICE (Rs)				TOTAL		
			BASIC	CST	VAT	ENTRY TAX			
BREAK-UP OF TOTAL PRICE AT SL NO 1.0 OF SCH-1.									
1.1	Total lumpsum pice for supply part, comprising of design & engineering, manufacture, inspection & testing at manufacturer's works, painting at manufacturer's works, duly packed for transportation, delivery to site etc for complete Compressed Air System Package including supply of erection materials, mandatory spares, consumables as required to complete the compressed air plants/equipments installation, maintenance tools & tackles for total scope defined in Specification No. PE-TS-400-555-A001 and terms & conditions of tender taking into account all clarifications, confirmations and agreements till the date of submission of offer for Compressed Air System for 2 X 500 MW NEW NEYVELI TPP.	1							
FINAL PRICE -SUPPLY PART									
1.2	Total lumpsum pice for service part, comprising of receipt, unloading, storage & handling at site, erection, Testing, commissioning, carrying out PG/ acceptance tests at site, final painting, handing over etc for complete Compressed Air System Package in line with drawings/documents/test procedures approved by BHEL/customer, complete with all accessories for total scope defined in technical specification Specification No. PE-TS-400-555-A001 and terms & conditions of tender taking into account all clarifications, confirmations and agreements till the date of submission of offer for Compressed Air System for 2 X 500 MW NEW NEYVELI TPP.	1							
FINAL PRICE -SERVICE PART									
TOTAL									

PRICE CST									
Design, engineering, manufacturing, supply, erection, commissioning etc of Compressed Air System for 2x500MW NNTPP, NEYVELL.									
TENDER DOCUMENT NO - PE-TS-400-555-A001									
SCH-3 - SUPPLY PRICE BREAK UP									
SL NO	DESCRIPTION	QUANTITY	BASIC	CST	TOTAL PRICE (Rs)			FREIGHT	TOTAL
					VAT	ENTRY TAX	TOTAL		
BREAK-UP OF SUPPLY PRICE AT SL NO 1.1 OF SCH-2									
1.1.1	Instrument Air Compressor (oil free Screw) Each of 36 NM ³ /Minute capacity at 9.0 kg/cm ² (g) consisting Electric motor to drive the compressor with accessories, Suction filter and silencer, Inter Cooler, After Cooler with moisture separators, automatic drain traps, instruments, Control panel etc.	3	Nos						
1.1.2	Air Dryer (HOC Type) Air Drying Plant of 36 NM ³ /min and to match instrument air compressor with all instruments and controls as specified.	3	Nos						
1.1.3	Service Air Compressor (oil free Screw) Each of 36 NM ³ /Minute capacity at 9.0 kg/cm ² (g) consisting Electric motor to drive the compressor with accessories, Suction filter and silencer, Inter Cooler, After Cooler with moisture separators, automatic drain traps, instruments, Control panel etc.	2	Nos						
1.1.4	Air receiver at Compressor house & Unit of 10 M³ capacity with each having Pressure switches, Relief valve, Drain connection with automatic trap stations and other accessories as specified.	7	Nos						
1.1.5	Inter connecting cooling water, compressed air, piping & Drain piping up to the nearest drain point as specified including fittings and valves, etc. for complete compressed air system.	1	Lot						
1.1.6	Field instruments as specified	1	Lot						
1.1.7	Cable, cable lugs, glands, etc for Compressed Air System equipment as required.	1	Lot						
1.1.8	Any other item / equipment required as per technical specification for successful & safe operation of Compressed air system.	1	Lot						
1.1.9	Total lump sum prices for Maintenance Tool & Tackles & commissioning spares (bidder to furnish item wise prices separately	1	Lot						
1.1.10	Total lump sum prices for mandatory spares as specified for compressed air System. (Bidder to furnish unit prices for each item in the Mandatory spares list separately along with the price bid).	1	Lot						
TOTAL									
FINAL SUPPLY PRICE FOR EVALUATION									

PRICE CST			
Design, engineering, manufacturing, supply, erection, commissioning etc of Compressed Air System for 2x500MW NNTPP, NEYVELI.			
TENDER DOCUMENT NO - PE-TS-400-555-A001			
SCH-4 - SERVICE PRICE BREAK UP			
SL NO	DESCRIPTION	QUANTITY	TOTAL PRICE (Rs)
BREAK-UP OF SUPPLY PRICE AT SL NO 1.1 OF SCH-2			
1.1.1	Instrument Air Compressor (oil free Screw) Each of 36 NM ³ /Minute capacity at 9.0 kg/cm ² (g) consisting Electric motor to drive the compressor with accessories, Suction filter and silencer, Inter Cooler, After Cooler with moisture separators, automatic drain traps, instruments, Control panel etc.	3 Nos	
1.1.2	Air Dryer (HOC Type) Air Drying Plant of 36 NM ³ /min and to match instrument air compressor with all instruments and controls as specified.	3 Nos	
1.1.3	Service Air Compressor (oil free Screw) Each of 36 NM ³ /Minute capacity at 9.0 kg/cm ² (g) consisting Electric motor to drive the compressor with accessories, Suction filter and silencer, Inter Cooler, After Cooler with moisture separators, automatic drain traps, instruments, Control panel etc.	2 Nos	
1.1.4	Compressor house & Unit air receiver of 10 M ³ capacity with each having Pressure switches, Relief valve, Drain connection with automatic trap stations and other accessories as specified.	7 Nos	
1.1.5	Inter connecting cooling water, compressed air piping & Drain piping up to the nearest drain point as specified including fittings and valves, etc. for complete compressed air system.	1 Lot	
1.1.6	Field instruments as specified	1 Lot	
1.1.7	Any other item / equipment required as per technical specification for successful & safe operation of Compressed air system.	1 Lot	
1.1.8	Cable, Cable lugs, glands, etc for Compressed Air System equipment as required.	1 Lot	
TOTAL			

PRICE CST		
Design, engineering, manufacturing, supply, erection, commissioning etc of Compressed Air System for 2x500MW NNTPP, NEYVELI.		
TENDER DOCUMENT NO - PE-TS-400-555-A001		
SCH-5 - IMPORT COMPONENTS		
SL NO	DESCRIPTION	AMOUNT
1.0	Total import content CIF values [in terms of Currency (Euro/ US \$) and correspondingly in INR as on date) included in total price/ supply price in SCH-1/ SCH-2/ SCH-3. (Bidder shall furnish item-wise list of imported items envisaged below)	

