



ISO 9001:2000  
& 14001:2004  
NAVARATNA  
COMPANY

भारत भारी विद्युत निगम (भारत भारी विद्युत निगम)  
**MATERIAL MANAGEMENT (PURCHASE)**  
भारत भारी विद्युत निगम (भारत भारी विद्युत निगम), भारत भारी विद्युत निगम (भारत भारी विद्युत निगम)  
**CENTRAL FOUNDRY FORGE PLANT, BHEL HARDWAR**  
भारत भारी विद्युत निगम (भारत भारी विद्युत निगम)  
**RANIPUR, HARIDWAR (INDIA) – 249403**  
Phone No. +91-1334-285326/284548, FAX No. 225892  
e-mail : [akaithal@bhelhwr.co.in](mailto:akaithal@bhelhwr.co.in) & [satul@bhelhwr.co.in](mailto:satul@bhelhwr.co.in)

M/S

**Sub:** Tender Enquiry No: FF/PPX/4416/P/920/8/76111V/1 DT 23/02/2008 Due on 10<sup>th</sup> Apr 2008.

Dear Sir,

We are pleased to invite offer as per enclosed specifications, drawings with terms and conditions in sealed covers for the under mentioned items.

| SI No | Tender No             | Description of Material   | Qty No | Date & Time of Opening  |
|-------|-----------------------|---|--------|---|
| 01    | 4416/P/920/8/76111V/1 | 1.FF9138091020<br>DRG:BRG-01,REV 00<br>BEARING SHELL<br>SPEC:HW-19361 | 32     | 10 <sup>th</sup> APRIL 2008<br>2:00 PM<br><br>TECHNO<br>COMMERCIAL<br>BID |

**KINDLY READ TERMS AND CONDITIONS. OFFER NOT IN ACCORDANCE WITH THE INSTRUCTIONS IS LIABLE TO BE DISQUALIFIED AND OR IGNORED.**

PLEASE VISIT [www.bhel.com](http://www.bhel.com) or [www.bhelhwr.co.in](http://www.bhelhwr.co.in) for more details and tender documents.

Thanking You,

Yours Faithfully,

For & On behalf of CFFP BHEL Hardwar

AJAY KAITHAL  
ENGINEER (PURCHASE)

**LIST OF DOCUMENTS:**

1. Annexure-A (General Terms and Conditions of Tender Enquiry).
2. Annexure-B (Commercial Terms )
3. Annexure-C (Check List)
4. Technical specifications and drawings
5. Performance Bank Guarantee Format and Consortium of Banks

**Note:** 1. Corrigendum if any shall not be published, kindly refer web for any changes.  
2. **Clause 5 “Note” of specification HW 19361 is not applicable.**



## GENERAL TERMS AND CONDITIONS OF TENDER ENQUIRY ANNEXURE-A

1. Submit the tender in two parts i.e.

**Part-I Techno-Commercial Bid**

**Part-II Price Bid**

Techno-Commercial (part one) & Price Bid (part two) should be put in separate sealed envelopes. Both envelopes should be super scribed with **Tender Number, Date of Opening & Technical / Commercial Bid and Price Bid** respectively along with name of firm.

Both the envelopes i.e. containing Techno-Commercial Bid and Price Bid should again be kept in one envelope super scribed again with Tender No. and Date of Opening and the name of firm submitting the tender and sent by Registered A/D post to **SDGM(MM),Purchase Department ,CFFP ,BHEL Hardwar,Ranipur ,Hardwar 249403.Uttarakhand ,India**

Part-I Envelopes super scribed with **Techno-Commercial Bid** must contain all information especially:-

(a) Specification of the material offered should be strictly as per CFFP/BHEL specifications of Enquired material in tender documents. **Deviations if any must be indicated clearly in the offer.**

(b) All commercial terms i.e. packing, forwarding, Custom Duty ,Additional Duty ,ST/STT/VAT/CST, Excise duty/CVD , Bank Charges, payment terms & Insurance etc as applicable should be clearly mentioned **except Price** .Also mention present rate of applicable taxes & duties even if inclusive in rates.

(c) Confirm to submit all required commercial documents (tax invoice, CENVATable duplicate copy of invoice, packing list, transit sale agreement etc.)& technical documents (TC/GC/QP etc.)

(d) Registration Numbers of SSI, Central Excise, Sales tax, Income tax, DGS & D, ECC etc.

(e) **Un-priced copy of Price Bid.**

Part-II Envelopes super **scribed with Price Bid** should contain **priced copy of Price Bid**. The price should be mentioned both **in figures and words**.

2. Authorized Signatory should authenticate all tender documents.

**3. Techno-commercial bid (Part-I)** will be opened on the due date at 2.00 PM. In the presence of participating vendors or authorized representatives, who may wish to be present? Representative deputed to witness tender opening must produce an authority letter from the signatory of offer. After evaluation of technical bids & finalization of technical, commercial terms & condition, price bid of only successful vendors will be opened. Priced bid opening date will be intimated separately.

4. The material offered must conform to the required BHEL specifications and drawings as well as instructions and details made available.

### **5. Eligibility:**

a) The Vendor must submit the annual reports giving the audited profit or loss account and balance sheet for last three financial years with year ending 31.03.07.

b) The Vendor have to submit the details of recent orders of similar material ( not earlier than 31.03.05) executed mentioning the Name and address of Customers with technical details preferably in India .

The Vendors who are registered with any unit of BHEL, India, in related category are exempted of above two. They should however give details of their registration.



**6. Original Test Certificate & other related Documents** from the Manufacturers or Government or Recognized Houses shall have to be produced as applicable without any extra cost. This may please be clearly confirmed in the quotation without which the offer may not be considered.

**7. Validity** of offers should be minimum of **90 working days** from the date of Tender (Techno-Commercial Bid) opening.

**8. Delivery** in the promised period is the essence of contract. Confirm to supply according to delivery schedule mentioned (Refer Annexure B)

**9. Payment Term** preferably should be within 30 days after receipt and acceptance of material else 1% incase of Indigenous Supply and 2% in case of foreign supply including High Seas Sales and CIF , as applicable will be loaded on Total Value without CENVAT in Landed Cost Calculation (refer Annexure B as well ). Vendors of Indian origin will not be paid through Letter of Credit .No advance amount will be paid .The indigenous supplier shall be paid through E-Mode .The format and requisites are attached.

**10.Loading** : 1)0.5% per week of delivery period extra after desired period metioned in Annexure B shall be loaded on total value without any CENVAT/MODVAT for comparison .The offer may be rejected if delivery period exceeds 20 weeks after desired period

**11.** CFFP/BHEL Hardwar reserves the right to accept or reject any or all tenders without assigning any reason there of.

**12.** Tenders not submitted in the prescribed manner are likely to be ignored/ rejected.

**13. Agent /Agency Commission:** Payment of any kind at any stage will not be made to Agent on account of agent commission or otherwise by CFFP BHEL Hardwar.

**14.** CFFP, BHEL, HARIDWAR may opt for **E-auction/Reverse auction** for obtaining best prices for part or full Tendered Quantity.

**15.** Please do intimate the personal contact details like Mobile Number, Email–Id, etc of authorized executive for correspondence.

**16. Penalty:** Orders placed against this Enquiry will be subject to normal clauses for imposing Penalty, Liquidated Damages, Risk purchases, and cancellation, arbitration as per terms and conditions of Purchase Orders in case of delay in effecting supply and or other defaults.

**17. Inspection:** CFFP BHEL Hardwar inspection after receipt shall be final and binding. BHEL may inspect at Vendor's work also. BHEL may nominate any testing house for inspection .The report shall be final and binding to both concerned .In case store is found defective during warranty period, the same will be returned for repair (if not possible in India by Vendor) and or replacement .For this Vendor has to bear all the charges such as Freight, i.e. to and fro, insurance etc .Bank Guarantee for the equal amount to the cost of the item is to be furnished by Vendor. In case the repair is done at CFFP/BHEL the amount on actual shall have to be reimbursed by the Vendor and or adjusted on actual from their Bill.

**18. Security Deposit and Performance Bank Guarantee** is must .The percentage of both proposed (Annexure B) if decreased the % of decrement than that proposed shall be loaded on Landed Cost Calculation .The minimum % acceptable shall be decided by CFFP/BHEL beyond which offer may be rejected .

**19.Disputes** : In event of any dispute arising out of Contractual obligation ,the order being finalized at Hardwar ,India will be subject to Indian Laws and falls under jurisdiction of the Court

of Law at New Delhi ,India .The overseas supplier hereafter referred to as “Vendor” shall therefore ,abide by the verdict of Court of Law at Hardwar ,India as may occur .

-OR-

All disputes arising out of or in connection with the present contract, if any, shall be finally settled under the rules of arbitration of International Chamber of commerce by one or more arbitrator appointed in accordance with the said Rules in India.

|  | <b>COMMERCIAL TERMS OF CFFP BHEL HARDWAR (ANNEXURE B)</b><br><b>(To be filled by Foreign (outside India) Vendor)</b>  |                    |                                |
|---|---|--------------------|--------------------------------|
| Sr No   | CFFP Terms and Conditions   | Agreed /Not agreed | If not agreed write your Terms |
| 1   | Payment Terms:100% payment by irrevocable Letter of Credit in full or parts .However 90% of order value shall be paid up to dispatch and balance 10% after Guarantee/warranty period.   |                    |                                |
| 2   | Security Deposit of 100% or amount for which Letter of Credit is to be opened must be submitted with Order Acceptance or within 30 days from Clearance to dispatch given by CFFP personnel which ever is applicable .The 90% security deposit must be valid up to receipt of material at CFFP BHEL Hardwar and balance 10% up to Guarantee/Warranty period. |                    |                                |
| 3   | Mode of Supply (FOB): Mention Port of Loading .All charges up to Port shall be borne by Vendor including Forwarder's fee whose name will be informed with Order.  |                    |                                |
| 4   | LD Clause : In case of delayed supplies ,Liquidated damage @ 0.5% per week of delay with a maximum of 10% of Order value will be levied   |                    |                                |
| 5   | Warranty : 24 months after receipt of material at CFFP or 12 months after commissioning at Power Plant which ever is later  |                    |                                |
| 6   | Performance related Warranty: Performance related Bank Guarantee of 10% of Order Value has to be submitted for Guarantee/warranty period before release of 90% of Order value payment   |                    |                                |
| 7   | Delivery Schedule: 8 No within 30 days,8 within 45 days and 16 Nos within 60 days of Order Date.  |                    |                                |
| 8   | Validity of Quotation :90 days of opening of Tender   |                    |                                |
| 9   | Transit insurance if applicable will be borne by Vendor   |                    |                                |
| 10  | After sales Support: Available through India based Agency   |                    |                                |
| 11  | Bank Charges in opening of L/c will be in respective account for irrevocable L/c  |                    |                                |

|    |   |  |  |
|----|---|--|--|
|    | .For any further requirement or amendment of L/c the charges thereof shall be borne by Vendor.  |  |  |
| 12 | Loading:0.5% per week of delivery period extra than that mentioned above shall be loaded on total value without any CENVAT/MODVAT for comparison .The offer may be rejected if delivery period exceeds 20 weeks after desired period. |  |  |

Signature & Seal of Vendor

**COMMERCIAL TERMS OF CFFP BHEL HARDWAR (ANNEXURE B)****(To be filled by Indigenous (Within India)Vendor )**

| Sr No | CFFP Terms and Conditions   | Agreed /Not Agreed | If not agreed write your Terms |
|-------|---|--------------------|--------------------------------|
| 1     | Payment Terms: 90% payment after receipt and acceptance of material within 30 days balance 10% after Guarantee/warranty period.   |                    |                                |
| 2     | Security Deposit: 100% of total Order Value must be submitted with Order Acceptance or within 30 days from Clearance to dispatch given by CFFP personnel which ever is applicable. The 90% security deposit must be valid up to receipt of material at CFFP BHEL Hardwar and balance 10% up to Guarantee/Warranty period. |                    |                                |
| 3     | Mode of Supply (FOR) : Material is to be supplied at CFFP BHEL Hardwar Stores   |                    |                                |
| 4     | LD Clause : In case of delayed supplies ,Liquidated damage @ 0.5% per week of delay with a maximum of 10% of Order value will be levied   |                    |                                |
| 5     | Warranty : 24 months after receipt of material at CFFP or 12 months after commissioning at Power Plant which ever is later  |                    |                                |
| 6     | Performance related Warranty: Performance related Bank Guarantee of 10% of Order Value has to be submitted for warranty period before release of payment of 90% of order value.   |                    |                                |
| 7     | Delivery Schedule: 8 No within 60 days,8 within 75 days and 16 Nos within 90 days of Order Date.  |                    |                                |
| 8     | Validity of Quotation :180 days of opening of Tender  |                    |                                |
| 9     | Transit insurance if applicable will be borne by Vendor   |                    |                                |
| 10    | After sales Support: Available  |                    |                                |
| 11    | Bank Charges if involved shall be borne by supplier.  |                    |                                |
| 12    | Loading:0.5% per week of delivery period extra than that mentioned above shall be loaded on total value without any CENVAT/MODVAT for comparison .The offer may be rejected if delivery period exceeds 20 weeks after desired period.   |                    |                                |

Signature &amp; Seal of Vendor



**CHECK LIST**  
**ANNEXURE C**  
**(To be filled by Vendor)**

| <b>Sr No</b> | <b>List of Questions</b>  | <b>Indicate Yes/No Below</b> |
|--------------|---|------------------------------|
| 1            | Have checked & understood all technical details as per specifications, literature and documents before quoting.   | Yes/No                       |
| 2            | Have all the pages signed by authorized and stamped with company's seal   | Yes/No                       |
| 3            | Have all taxes and duties mentioned with value applicable as on date along with MODVATable duties and/or taxes if any with actual value(%) to be claimed  | Yes/No                       |
| 4            | Have all commercial points filled as per Annexure A and filled Annexure A is attached.  | Yes/No                       |
| 5            | Have Techno Commercial bid Price Blanked out  | Yes/No                       |
| 6            | Have Eligibility Criteria (Clause 5 Annexure-I) understood and requisites as applicable attached.   | Yes/No                       |
| 7            | Have Price Bid replica of Techno Commercial Bid without additional documents priced   | Yes/No                       |
| 8            | Have three separate envelopes super scribing Tender Reference with due Date along with your company name at bottoms each for Techno-Commercial Bid, Price Bid and Envelope Containing both, prepared. | Yes/No                       |
| 9            | Have personalized contact details like Email Id ,Mobile No and Fax No are mentioned for correspondence  | Yes/No                       |

**LIST OF CONSORTIUM BANKS:**

- |   |   |
|---|---|
| 1. State Bank of India<br>CAG Branch,<br>10-th Floor, Vijaya Building,<br>Barakhamba Road,<br>New-Delhi-110001              | 10. HDFC Bank Ltd<br>5 <sup>th</sup> Floor, HT House,<br>K G Marg,<br>New-Delhi-110001          |
| 2. Canara Bank<br>74, Janpath,<br>New-Delhi-110001  | 11. CITI Bank N A<br>Jeevan Vihar Building,<br>Sansad Marg,<br>New-Delhi-110001                 |
| 3. Punjab National Bank<br>74, Janpath,<br>New-Delhi-110001   | 12. Standard Chartered Bank<br>H2 Block, Connaught place,<br>New-Delhi-110001                   |
| 4. Bank of Baroda<br>Corporate Banking Branch,<br>11 <sup>th</sup> Floor, BOB Building,<br>Sansad Marg,<br>New-Delhi-110001 | 13. ICIC Bank Ltd.<br>ICIC Tower,<br>Bisham Pitamah Marg,<br>Pragati Vihar,<br>New Delhi 110003 |
| 5. Deutsche Bank<br>Tolstoy Marg,<br>New-Delhi-110001   | 14. IDBI Bank Ltd.<br>19, K G Marg,<br>Surya Kiran Building,<br>New-Delhi-110001                |
| 6. State Bank of Hyderabad<br>Surya Kiran Building,<br>K. G. Marg,<br>New-Delhi-110001                                      | 15. HSBC Ltd.<br>ECE House,<br>28 KG Marg,<br>New-Delhi-110001                                  |
| 7. State Bank of Mysore<br>Antriksh Bhawan,<br>K. G. Marg,<br>New-Delhi-110001  |   |
| 8. State Bank of Mysore<br>Industrial Finance Branch,<br>Ramanashree Arcade,<br>MG Road,<br>Bangalore-560001                |   |

9. State Bank of Travancore  
Travancore House,  
IF Branch, K G Marg,  
New-Delhi-110001

**PROFORMA FOR SECURITY DEPOSIT  
(TO BE STAMPED IN ACCORDANCE WITH STAMP ACT)**

This deed of guarantee made this .....day of .....Two Thousand.....by (bank) hereinafter called ‘the Guarantor’) which expression shall unless repugnant to the context or meaning thereof be deemed to include its successors and assigns)IN FAVOUR OF M/s Bharat Heavy Electricals Limited (A Government of India Undertaking ) a Company incorporated under the Companies Act, 1956 having its registered office at “BHEL House” Siri Fort, New Delhi 110 049 , through its Unit/Division at Hardwar (Central Foundry Forge Plant) hereinafter called “the Company” (which expression shall unless repugnant to the context of meaning thereof be deemed to include its successors and assigns).

WHEREAS M/s..... (hereinafter referred to as the vendor) have entered into a contract bearing no.....Dated.....(Hereinafter referred to as “the Contract”) for the supply of .....With the Company.

AND WHEREAS the Contract interalia provides that the vendor shall furnish Security Money to the Company in the form a Bank Guarantee for a sum of Rs.....(Rs.....only) as Security for due and faithful execution of deliveries within specified period in the contract.

AND WHEREAS THE VENDOR has approached the Guarantor and in consideration of the arrangement arrived at between the Vendor and Guarantor; the Guarantor has agreed to give the guarantee as hereinafter mentioned in favour of the Company.

**NOW THIS DEED WITNESS AS FOLLOWS:-**

- (1) The Guarantor do hereby guarantee to the Company the due and faithful performance, observance or discharge of the Contract by the Vendor and further unconditionally and irrevocable undertake to pay the Company without demur and merely on demand to the extent of ..... Any claim made by the Company on them for any loss, damage, costs charges and expenses caused to or suffered by the company by reason of the vendor making any default in the performance, observance or discharge of the terms , conditions stipulations or undertakings or any one of them gas contained in the Contract.
- (2) The decision of the Company whether any default has occurred or has been committed by the Vendor in the execution of the supplies, observance or discharge of any of the terms, conditions stipulations or undertakings or any one of them as contained in the Contract and or as to the extent of loss, damage, costs ,charges and expenses caused to or suffered by the Company by reason of the vendor making any default in the performance, observance or discharge of any of the terms, conditions, stipulations or undertakings or any one of them shall be conclusive and binding on the Guarantor irrespective of the fact whether the vendor admits or denies the default or questions the correctness of any demand made by the company in any Court, Tribunal or Arbitration Proceedings or before any other authority.
- (3) The Company shall have fullest liberty without affecting in any way the liability of the Guarantor under this guarantee, from time to time to enforce or forbear from enforcing any of the terms and conditions governing the contract or securities available to the Company and the Guarantor shall not be released from its liability under these presents by any exercise by the Company of the liberty with reference to the matters aforesaid or by reason of time being given to the vendor or any other forbearance, act or commission of the part of the company or

any indulgence by the company to the vendor or of any other matter or thing whatsoever which under the law relating to sureties, would but for this provision have the effect of so releasing the Guarantor from its liability under this Guarantee.

- (4) The Guarantor further agree that the Guarantee herein contained shall remain in full force and effect during the period that would be taken to the performance of the Contract and that it shall continue to be enforceable till all the dues of the Company under or by virtue of the said Contract have been fully paid and its claims satisfied or discharged and till the Company certifies that the terms and conditions of the Contract have been fully and properly carried out by the Vendor and accordingly discharges this Guarantee, subject, however, that this Guarantee is only valid for written demands by the Company on or before.....(specify date).

The Guarantor undertake not to revoke this Guarantee during the period it is in force except wit the previous consent of the Company in writing and agree that any liquidation or winding up or insolvency or dissolution or any change in the constitution of the Vendor α the Guarantor shall not discharge the Guarantor's liability hereunder:

It shall not be necessary for the Company to proceed against the Vendor before proceeding against he Guarantor and the Guarantee herein contained shall be enforceable against them notwithstanding any security which the Company may have obtained or obtain from the Vendor shall at the time where proceedings are taken against he Guarantor hereunder by outstanding or unrealized.

The Guarantor hereby declares that it has power to execute this guarantee under it is Memorandum and Articles of association and the executants has full powers to do so on its behalf under the Power of Attorney dated.....granted to him by the proper authorities of the Guarantor..

IN WITNESS whereof the ..... (Bank) have caused this deed to be signed hereunder or their behalf on the date first above mentioned.

**Signed for and on behalf of the (Bank)**

Name:

Designation:

Address:

Fax No. (With country code):

E-mail address:

**NOTE: IN CASE A BANK IN INDIA IS GIVING THIS BANK GUARANTEE; IT WILL BE EXECUTED ON A STAMP PAPER OF RS. 62.50 BUT IF IT WILL BE FROM AN OVERSEAS BANK, IT WILL HAVE TO BE EXECUTED AS PER LAWS OF THAT COUNTRY.**





संस्थान क्रय विनिर्देश (डीप - हरिद्वार)

HW 19361

पृष्ठ का  
Page 1 of 4

**PLANT PURCHASE SPECIFICATION**  
(HEEP - HARIDWAR)

**STEEL FORGINGS FOR BEARING LINERS / SHELLS**  
(Gr : C 22+N)

Based on TLV 9056 01 10/1999

SUPERSEDES INVENTORY NO

COPYRIGHT AND CONFIDENTIAL

स्वत्वधिकार एवं गोपनीय

संकेत एवं तिथि

संकेत नं. व तिथि

The information on this document is the property of Bharat Heavy Electricals Limited. It must not be used directly or indirectly in any way detrimental to the interest of the company.

इस दस्तावेज में दी गई सूचना भारत भारी इलेक्ट्रिकल्स की संपत्ति है। इसका प्रयोग केवल भारत भारी इलेक्ट्रिकल्स के लिए ही किया जाना चाहिए, जो कि कंपनी के हित में उपयोग के लिए है।

- 1.0 GENERAL:  
This specification governs the quality requirements of low hydrogen content Steel Forgings (Gr: C 22+N ; material no. 1.0402) in heat treated condition.
- 2.0 APPLICATION:  
Suitable for bearing liners / shells to be used for babbitting purpose.
- 3.0 CONDITION OF DELIVERY:  
Normalized.  
Unless otherwise specified in BHEL order / drawing, rough machining of the forgings shall be carried out.
- 4.0 DIMENSION AND TOLERANCES:  
Forging shall be supplied to the dimensions and tolerances as per the ordering drawing.
- 5.0 MANUFACTURING:  
Forgings shall be manufactured from steel produced by the electric furnace. Hydrogen content in the steel shall not exceed 3 ppm. It is recommended to use vacuum treated steel . If this is not feasible, then dehydrogenation annealing is to be carried out at 650°C for 30 hours. The prescribed hold time of 30 hours may be achieved during successive heat treatment (e.g. 5 X 6 hours), provided a cumulative hold time of 30 hours at 650°C is obtained.  
  
Sufficient discard shall be made from each ingot to ensure freedom from pipe, segregation and other defects. The ingot shall be thoroughly forged under suitable press / hammer to ensure homogeneity throughout the complete section.  
  
**Note:** Raw material like Ingots/Blooms/Billets required for forgings shall be procured from BHEL approved sources along with test certificate."
- 6.0 HEAT TREATMENT:  
The forging shall be normalized as per EN 10083-2 to get the mechanical properties specified as per CI 11.0.  
Normalizing temperature shall be between 880-920°C.

| संकेत एवं तिथि  | नाम           | दिनांक एवं हस्ताक्षर | नाम              | दिनांक एवं हस्ताक्षर       |
|---|---------------|----------------------|------------------|----------------------------|
| REV   | AGREED DEPTT  | DATE & SIGNATURE     | NAME             | SIGNATURE & DATE           |
| TSX   | AK CHATURVEDI | 20.03.07             |                  |                            |
| IPSc  | S.K. SONKAR   | 20.03.07             | अनुवादक          | TRANSLATED BY              |
| STE   | A.K. GOSWAMI  | 21.2.06              | परीक्षणकर्ता     | WORKED BY                  |
| QAX   | N.K. MANDAL   | 21.2.06              | जांचकर्ता        | CHECKED BY                 |
|   |               |                      | सर्वनिर्वाहकर्ता | SUPERVISED BY              |
|   |               |                      | V.B. ARORA       | 21/2/06                    |
| स्वीकृति : संस्थान मानक समिति<br>APPROVED : PLANT STANDARDS COMMITTEE |               |                      |                  |                            |
| REV 02  |               |                      | संकेत            | जारी : मानक विभाग          |
| 20.03.07  |               |                      | PREPARED: MTE    | ISSUED: STANDARDS DIVISION |
|   |               |                      |                  | दिनांक : 26-8-86           |



संस्थान क्रय विनिर्देश (हीप - हरिद्वार)

HW 19361

PLANT PURCHASE SPECIFICATION  
(HEEP - HARIDWAR)

पृष्ठ का  
Page 2 of 4

सुपरसेड इन्वेंटरी नं०  
SUPERSEDES INVENTORY NO

COPYRIGHT AND CONFIDENTIAL  
The information on this document is the property of Haridwar Heep Electrical Limited it must not be used directly or indirectly, in any way, detrimental to the interest of the company.

स्वत्वधिकार एवं गोपनीय  
इस दस्तावेज में उल्लिखित सभी विवरणों का अधिकार हरिद्वार हीप इलेक्ट्रिकल लिमिटेड का है। इस दस्तावेज को बिना लिखित अनुमति के किसी भी प्रकार से प्रसारित नहीं किया जा सकता है।

एंगेज के दिनांक  
SIGN & DATE  
11/19/07

सुपरसेड इन्वेंटरी नं०  
INVENTORY NO  
P-2981

7.0 FINISH:

As mentioned in the drawing.

8.0 FREEDOM FROM DEFECTS

The forgings shall be free from defects such as cracks, flakes, seams, segregation, non-metallic inclusions and other defects which may affect the utility of the forgings.

9.0 CHEMICAL COMPOSITION

Heat analysis in weight % shall be as follows:

|          |             |        |         |                |             |
|----------|-------------|--------|---------|----------------|-------------|
| C        | 0.17 - 0.24 | Si     | ≤ 0.40  | Mn             | 0.40 - 0.70 |
| P        | ≤ 0.045     | S      | ≤ 0.045 | Cr             | ≤ 0.40      |
| Mo       | ≤ 0.10      | Ni     | ≤ 0.40  | H <sub>2</sub> | ≤ 3 ppm     |
| Cr+Mo+Ni |             | ≤ 0.63 |         |                |             |

Slight deviation in chemical composition are permissible after agreement by the purchaser, provided service properties are not affected. However, the maximum carbon content shall not be exceeded.

10.0 TEST SAMPLES:

A hardness test shall be performed on all forgings.

The mechanical properties (1 tensile specimen) are to be determined at one forging per melt and heat treatment batch. In the case of rings, the specimens are to be taken out of a tangential ring.

In case of bars, the specimens are to be taken in longitudinal direction according to EN 10083-1. For bars with diameter (d) or side lengths (a,b) > 100 mm, the specimens shall be taken at a distance d/3 or a/3 and b/3 from the respective surfaces. In this case, transverse specimens are also allowed. Additional tests are to be specially agreed upon.

When different dimensions are produced within the same heat and heat treatment batch, the heaviest one shall be used for the determination of the mechanical properties. The tangential test ring or the sample for determination of the mechanical properties may not be cut from the forging before the heat treatment.

11.0 MECHANICAL PROPERTIES

Mechanical test, shall always be carried on the heaviest section forgings of the same melt and heat treatment batch.

11.1 Tensile:

When tested as per IS:1608, the test pieces after being heat treated as per Cl:6.0 shall show the following properties.

|                             |   |                              |
|-----------------------------|---|------------------------------|
| Yield strength              | : | 240 N/mm <sup>2</sup> , min. |
| Tensile strength            | : | 420 - 530 N/mm <sup>2</sup>  |
| Elongation (l = 5d), % min. | : | 27                           |

REV 02

|                           |            |  |          |
|---------------------------|------------|--|----------|
| निर्माणकर्ता<br>WORKED BY | ASHISH     |  | 20.03.07 |
| जांचकर्ता<br>CHECKED BY   | J.P. Meena |  | 20.03.07 |



PLANT PURCHASE SPECIFICATION

(HEEP - HARIDWAR)

सुपरिन्टेंडेंट  
INVENTORY

सुपरिन्टेंडेंट को  
प्रदान किया गया है

स्वत्वाधिकार एवं गोपनीय

सुपरिन्टेंडेंट को प्रदान किया गया है। इस दस्तावेज़ को स्वतंत्र रूप से प्रसारित करने से बचना चाहिए।

हस्ताक्षर एवं तिथि  
SIGN & DATE

20/1/06

सुपरिन्टेंडेंट को  
INVENTORY NO.

P-2981

11.2 HARDNESS - BRINELL (For information only): min. 120 HB30

12.0 NONDESTRUCTIVE TESTING:

12.1 Following NDE shall be performed in delivery condition:

- Visual inspection
- 100% UT- inspection according to EN 10228-3.

Depending on the forging geometry, following inspection types are applicable:

- for long type components type 1 (table 3)
- for discs and plate- like components: type 2 (table 3)
- for ring or bushing- like components: type 3b and 3c (table 3)

12.2 Criteria for registration and decision

Regarding the UT- inspection quality class 3 (table 5) according to EN10228-3 shall be applied.

The decision limit for loss of back wall echo is  $\leq 4$  dB and for the real reflector length 10 mm.

13.0 RECTIFICATION OF DEFECTS:

Rectification of defects in forgings shall not be carried out by the supplier without the prior written permission of BHEL.

14.0 TEST CERTIFICATES:

Unless otherwise stated in the order, three copies of test certificates shall be supplied as per 3.1 of EN10204.

In addition, the supplier shall ensure to enclose one copy of the test certificate alongwith their despatch documents to facilitate quick clearance of the material.

The following details shall be furnished in the test certificate:

HW19361 : Steel forgings – C 22+N  
 BHEL order  
 Heat No. , and melting type.  
 Dimensional inspection  
 Details of heat treatment cycle followed.  
 Results of chemical analysis  
 Results of mechanical tests, including hardness test. All individual values shall be reported.  
 Results of ultrasonic tests  
 Confirmation of the visual inspection  
 Results of additional tests called for in the drawing/order.  
 Mill test certificate

REV 02

|                           |         |        |         |
|---------------------------|---------|--------|---------|
| निर्माणकर्ता<br>WORKED BY | ASHISH  | Alayaz | 20/2/06 |
| जांचकर्ता<br>CHECKED BY   | P. NATH | प. नथ  | 20/2/06 |



**PLANT PURCHASE SPECIFICATION**  
(HEEP - HARIDWAR)

सुपरिन्टेंडेंट  
SUPERVISOR  
INVENTORY

संस्था की संपत्ति है।  
The information on this document is the property of Bharat Heavy Electrical Limited. It must not be used directly or indirectly in any way detrimental to the interest of the company.

स्वत्वधिकार एवं गोपनीय  
इस दस्तावेज में दी गई सूचना भारत भारी इलेक्ट्रिकल्स लिमिटेड की संपत्ति है। इसका प्रयोग केवल अनुमत क्षेत्र में ही किया जा सकता है। अन्यथा इसकी प्रतिलिपि बनाना या इसकी प्रतिलिपि को किसी भी माध्यम से प्रसारित करना गैर कानूनी है।

ड्राइंग का दिनांक  
SIGN & DATE  
20/2/06

संस्था की संपत्ति है।  
INVENTORY NO.  
P-2981

**15.0 DEVIATIONS**

Any deviation from this delivery specification has to be reported to BHEL immediately using Performa PU-25 supplied with the order. Any deviation is generally accepted only if this has been approved by BHEL in a written form.

**16.0 CLEARANCE FOR DELIVERY**

The clearance for dispatch is based on the total results of all tests performed considering the service stresses of the component. BHEL has the right to accept deviations of the specified values, if it is shown by individual judgment that the service properties are not reduced.

The clearance does not release the manufacturer from the responsibility for hidden defects that are detected at later stage of manufacturing.

**17.0 PACKING AND MARKING:**

Forgings shall be suitably packed to prevent corrosion and damage during transit.

Machined surfaces shall be properly protected with anti-corrosive compounds.

Each package or forging (when supplied separately) shall be legibly marked with the following information:

- HW19361
- BHEL Order No.
- Drawing no.
- Batch No.
- Weight.
- Supplier's name.

**18.0 REFERRED STANDARDS (Latest Publications including Amendments):**

- 1. IS : 1608
- 2. EN 10228-3.
- 3. EN10204
- 4. EN10083-1
- 5. EN10083-2

REV 02

|                           |          |                 |         |
|---------------------------|----------|-----------------|---------|
| निर्माणकर्ता<br>WORKED BY | ASHISH   | <i>Ashish</i>   | 20/2/06 |
| जांचकर्ता<br>CHECKED BY   | P. N. N. | <i>P. N. N.</i> | 20/2/06 |

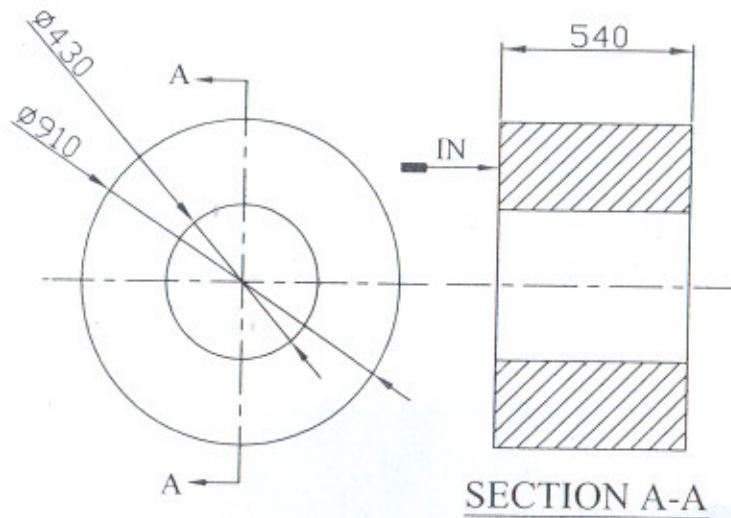

**NOTE:**

1. FORGING SHALL BE SUPPLIED EXACTLY IN CONFORMITY WITH THE PURCHASE SPECIFICATION HW19361
2. FORGING SHALL BE SUBJECTED TO DEHYDROGENATION ANNEALING TREATMENT AT 650° FOR 24 HOURS IF VACUUM DEGASSED STEEL IS NOT USED.
3. FORGING SHALL BE ULTRASONICALLY TESTED AS PER HW19361
4. IDENTIFICATION MARKING SHALL BE DONE AT THE PLACE MARKED IN
5. TOLERANCE ON O.D +3,-0  
ON I.D +0,-3  
ON THICKNESS +5,-0
6. SUPPLIER SHALL LOCATE THE POSITION OF TEST SAMPLE FOR MECHANICAL TESTING.

| REV. | DATE | ALTERED BY | REV. | DATE | ALTERED BY | REV. | DATE | ALTERED BY |
|------|------|------------|------|------|------------|------|------|------------|
|      |      |            |      |      |            |      |      |            |
|      |      | CHECKED BY |      |      | CHECKED BY |      |      | CHECKED BY |



C.F.F.P.  
FORGE SHOP

|       |     |              |         |
|-------|-----|--------------|---------|
| DRN.  | AKK | <i>Edman</i> | 23/1/08 |
| CHD.  | AKS | <i>AKS</i>   | 23/1/08 |
| APPD. | SRV | <i>SRV</i>   | 30-1-08 |

ITEM

**BEARING  
SHELL**

COND.

AS DELIVERED

MATERIAL : HW -19361

SCALE : N.T.S. WT. : 2140 Kg

|          |          |                    |
|----------|----------|--------------------|
| CUSTOMER | NAME     | CFFP HARDWAR       |
|          | DRG. NO. | 3-139-01-00006 R07 |

CFFP DRG. NO.

D - BRG-01

REV. NO.

00