

ENQ.NO.664087E		INDEX FOR ATTACHED DOCUMENTS	DATE: 10.01.2015
S.N	Section	Description	File name ref
1	Section I	Notice Inviting Tender	Section-I.pdf
2	Section II	Work Related Special Conditions	Section-II.pdf
3	Section III	Labour Related Statutory General Conditions	Section-III.pdf
4	Section IV	General Terms and Conditions of the Tender	Section-IV.pdf
5	Section-V	Safety Conditons	Section-V.pdf
6	Annexure-A	Check List for Cover-I	Annexure-A.pdf
7	Annexure-B	Techno Commercial Offer Format	Annexure-B.pdf
8	Annexure-C	Price Bid Format	Annexure-C.pdf
9	Annexure-D	Scope of Work	Annexure-D.pdf
10	Annexure-E	Suspension of Business Dealings with Vendors	Annexure-E.pdf
11	Annexure-G	Certification FOR MSME	Annexure-G.pdf
12	Annexure-J	Authorization letter for attending tender opening	Annexure-J.pdf
13	Annexure-K	Vendor Registration Forms	Annexure-K.pdf



An ISO
Company

BHARAT HEAVY ELECTRICALS LIMITED

(A Government of India Undertaking)

பாரதமிகுமின் நிறுவனம்

BOILER AUXILIARIES PLANT, Indira Gandhi Industrial Complex,
RANIPET- 632 406 (Tamil Nadu)

Ph: 04172-284030,
284158,284323, 241170
Email: rvr@bhelrpt.co.in
mkmoorthy@bhelrpt.co.in

SECTION – I

NOTICE INVITING TENDER (NIT)

(This is only a request for an offer and not a Contract)

Sealed Tenders are hereby invited from experienced Sub-Contractors to finalise the Rates for entering into Annual Rate Contract for the year 2015-16 for Manufacturing of Steel Boxes for Packing within BHEL Factory premises in accordance with the Technical Specification/BHEL Engineering Drawings/Quality Documents out of materials/components to be supplied by BHEL/Ranipet as free issue.

Enquiry No. & Date	664087E & Date 10-Jan-2015
Due Date & Time for Submission Of Offer	12-02-2015 Prior to 14.00 Hrs.
Date & Time for Tender Opening (Other than Price Bid)	12-02-2015 at 14.30 Hrs.
Place Of Submission Of Offer	At Tender Box located in Outsourcing department, Third Floor, Administrative Building, BAP/BHEL/Ranipet-632406.
Place Of Tender Opening	OS Department at Third Floor/BAP/BHEL/Ranipet

This tender specifies a set of prequalification criteria defining the eligibility for the vendors to quote against this tender. The Bidders are advised to go through all the enclosed Tender documents terms & conditions detailed under **Sections I to V, Annexures- A to E** carefully before submitting their Offer.

All the **Annexures- A to E** should be filled, wherever applicable by the bidders without fail for evaluation of their offer and **all necessary supporting documents** as required are to be attached.

The bid shall be submitted in TWO parts namely (1) Techno Commercial Bid and (2) Price Bid.

Kindly refer to the **Section-IV** – General Terms and Conditions of the tender for detailed procedure for submission of offers and details of exemption from submission of EMD for vendors registered with MSME

Kindly refer to Section-II and Annexure-D for detailed scope. Sealed Tenders are hereby invited from experienced Sub-Contractors for the above scope.

Note: Number of Sources required is Four only

Contact details / address for any clarification and for Offer submission.

Manager-(Contracts-LDPP)
Outsourcing Department, Boiler Auxiliaries Plant
Bharat Heavy Electricals Limited, ,Ranipet-632406
Phone : 04172-284030, 284158, 241170, 284323
E-Mail : mkmoorthy@bhelrpt.co.in, rvr@bhelrpt.co.in

Manager(Contracts-LDPP)/OS



Enquiry Number: 664087E

Dt.10.01.2015

SECTION II

WORK RELATED SPECIAL CONDITIONS

1. The works are to be carried out and/or to be completed within the stipulated period and if necessary the contractor shall take necessary steps to augment the work force.
2. BHEL will allocate suitable open yard space inside BHEL premises for carrying out of the scope of work covered in this Tender. Sufficient levelled open area will be provided by BHEL. Further leveling, consolidation if required, will have to be carried out by the Contractor.
3. For manufacturing of Steel Boxes inside BHEL's Factory Premises with BHEL material and as per BHEL drawing, apart from providing of Open Yard-Space, Power supply and Consumables Restricting to Compressed Air, Welding Electrode and Paints are to be supplied by BHEL. Oxygen and Acetylene required for welding, arrangement of internal transport for movement of materials within factory premises and any other consumables required are with Vendor's scope.
4. The contractor shall be solely responsible for the safe custody for the materials from the time the documents are handed over to him till the materials are delivered at the places specified and will indemnify the BHEL against loss, damage, breakage, shortage and pilferage of any materials while in their custody. BHEL norms shall be followed for all BHEL free issue items. Transport insurance, if any, has to be paid by the contractor as may be directed by BHEL.
5. The period of the contract may be reduced, renewed or extended at the discretion of BHEL.
6. In case of any neglect or refusal on the part of the contractor to provide and non-readiness, insufficient readiness, insufficient labour for the aforesaid work or if in the opinion of Officer-in-charge, the services provided by the contractor are not satisfactory, the Officer-in-charge shall be at liberty to make such arrangement as he may deem fit at the cost and expense of the contractor. The contractor shall be advised of the amount so incurred and he shall be bound to remit the sum within three days from the date of receipt of such advice. Failure to do so will entitle the Officer-in-charge to deduct the sum from the Security Deposit or from any money due to the contractor. Also BHEL reserves the right cancel the such contract and initiate alternate action at the Cost & Risk such tenderer.
7. The contractor shall either supervise the work or provide a supervisor to supervise the work of their staff. The supervisor employed by the contractor shall ensure proper out-turn of work and the discipline by the labour to be put on the job and in general see that the works are carried out in a safe and proper manner. The supervisor shall have technical qualification and experience to carry out the jobs.
8. The contractor shall withdraw their labour only after obtaining the prior approval of the Officer-in-charge and they shall arrange to re-employ the labour within a day from the date of intimation to them.
9. BHEL will not be responsible for the idle labour of the contractor for whatever reasons.



10. Should any error or ambiguity be discovered in the specification or information, the contractor shall forthwith bring the same to the notice of BHEL before commencement of work. The BHEL's interpretation in such cases shall be final and binding on the contractor.

11. In case the labour strength has to be increased to complete the work within the stipulated period, no extra claim for payment under any circumstances will be entertained.

12. BHEL reserves the right to decide the suitability of the workers and other personnel who may be employed by the contractor. All movements of Men & Material are to be done through BHEL-East Gate/Shipping Gate only

13. In case of damage or loss to any equipment's or components or any property of BHEL caused due to the negligence and carelessness of the contractor's men, the responsibility shall rest with the contractor. The actual cost of the damage or loss together with the overhead will be recovered from the contractor's bill. The decision of BHEL regarding the cost as well as the extent of cost of damage shall be final and conclusive. Necessary insurance coverage for all the risks to be taken by contractor.

13. The contractor if required has to work in late hours with sufficient manpower to complete the task within the specified schedule date, BHEL will provide the necessary permission only. All the other things are to be taken care by the contractor.



Enquiry Number: 664087E

Dt.10.01.2015

SECTION - III

LABOUR RELATED STATUTORY GENERAL CONDITIONS

1. The Contractor shall comply with the 'Minimum Wages Act 1948 – Fixation of Minimum Rates of Wages for the employment in General Engineering and Fabrication Industry and provisions of payment of Wages Act 1936 or any modification or any other law relating there to and the rules made there under from time to time.
2. The contractor has to pay not less than the minimum wages to all workers as stipulated by the Government of Tamil Nadu from time to time applicable for Engineering and Fabrication Industries. These workers shall be paid Dearness Allowance (DA) also along with the wages as specified by the Government of Tamil Nadu. If any change in the minimum wages is effected in the subsequent order of Government of Tamil Nadu during the period of contract, the contractor is bound to pay the revised wages as specified in the Government Order.
3. Apart from the existing minimum wages the contractor shall pay to the labour an additional payment of Rs.3200/month for USW, Rs.3700/month for SSW and Rs.4100/month for SW. The statutory payments like PF, ESI, Etc is also applicable for this additional payment in addition to the minimum wages as specified by the state government. Contractor quoted rate shall be inclusive of this all the above payments including statutory payments thereon. Present wage applicable is tabulated hereunder.

Wage Element	USW	SSW	SW
Monthly Basic Pay	3600	3840	4050
Monthly DA	4175	4175	4175
BHEL Adhoc	3200	3700	4100
Total Wages	10975	11715	12325

USW- PERSONS DOING WORK WHICH DO NOT REQUIRE ANY TRAINING

SSW- ALL TRADE CERTIFICATE HOLDERS INCLUDING ITI

SW- PERSONS WITH TRADE CERTIFICATES INCLUDING ITI WITH EXPERIENCE OF 3 YEARS AND ABOVE

4. The wages shall be disbursed on or before 10th day of the succeeding month. If 10th falls on a holiday, payment should be made on 7th day or previous working day. Advance intimation regarding payment date, time and venue shall be given to the official-in-charge. In case the contractor failed to pay the wages to the workers on or before 10th day of the next month, BHEL has the right to pay the contract workers and deduct the same from the amount payable to the contractor. The Official-in-charge shall certify at the end of the entries in the Register of wages.
5. There should not be any distinction in the payment of wages made between Men and Women workers engaged in work of similar nature performed by them.
6. As per Contract Labour (R&A) 1970 and the Factories Act 1948 & Rules 1950, the contractor shall maintain Time Cards in Form 25-B and issue the same to every contract labourer employed by him.
7. Weekly Off and Leave with Wages: No contract labourer shall be allowed to work continuously for more than 6 days in a week



8. Apart from this, contractor should provide to every labourer employed by him one day of leave with full wages for every 20 days of actual work engaged by him. The contractor shall also maintain up to date Register of Leave with wages in Form – 15 as prescribed under Rule 87 & 88 of Factories Act 1948.
9. The contractor should possess necessary licenses, PF A/c No., and should take Insurance for his workers and produce them before commencement of work. If P.F. A/c No. is not already allotted, until such allotment is obtained, a sum of equal to 20% of the bill value will be retained. The sum so retained will be released on production of proof of remittance to the PF Authorities. The contractor shall ensure PF remittances for all his labourers working during the month. Any short fall in PF remittances shall be recovered from the contractor's bills.
10. As per employees PF and miscellaneous Provisions Act 1952, the employees' contribution payable at present is 12% of wages which shall be recovered by the contractor from the wages of his workmen and the contractor should pay equal contribution in addition to any administrative charges in this behalf that may be decided from time to time. Remittance shall be made on time (i.e. on or before 15th of the following month).
11. All the contract workers shall be enrolled in ESI (Employees' State Insurance). The effective date will be first day of the latest commencement of running contract concerned. The date shall be entered in the "Date of Appointment" column of the ESI Declaration Form. Our ESI Code No. is 51-4766/Ranipet.
12. The workers who are already members of ESI need not be enrolled again.
13. The filled ESI declaration forms shall be submitted to the Executive/HR Department. In the Declaration Form full address of the contractor shall be mentioned. Whenever a fresh and unregistered worker is engaged during the operation of contract, declaration form in respect of the workman which should be submitted to Human Resources Department within two days of such engagement.
14. ESI contributions (1.75% employees contribution + 4.75% employer contribution of the total monthly wages) before 20th day of every following month. (ESI Code No.51-4766/R). Prescribed challans are available at ESI local office, Ranipet(near SIPCOT). Contractors who have got their own code number can remit the contributions on that number.
15. Along with the Challan copy, the details of remittance shall be submitted to the Executive (HR-CLX,REX) in the ESI compliance form.
16. The contractor should deduct Provident Fund and ESI amount as per the provisions and amount so deducted along with the matching contribution of the contractor shall be remitted to the authorities concerned within the stipulated time. The statement of deduction along with the challans evidencing remittance shall be submitted to Officer-in-charge. If the evidences are not shown, further bills of the contractor will not be paid. BHEL have the right to withhold the payment of his bills. Submission of statutory returns such as Half Yearly returns of ESI(Form6), PF return (Form12A). Form 5 and Form 10, Form 3A & Form 6A should be sent to the concerned officers in time.
17. In case of any increase in wage rates on account of revision of minimum wages by Government of Tamil Nadu and any revision of contribution in Provident Fund, ESI and Bonus percentages due to statutory amendments, the contractor is bound to pay the revised amount. In case the revision of minimum wages is made by Government of Tamil Nadu with retrospective dates, the contract is bound to pay such arrears arising out of such revision of minimum wages retrospectively, failing which BHEL as the principal employer will retain the amount from the contractor and pay to contract labourers working under him.
18. The workers' particulars such as Name, Age, Father's Name, address etc., and their daily attendance have to be maintained by the contractor. The details of Provident Fund and ESI compliance have to be maintained by the contractor in the prescribed format / register.



19. As per the Contract (Regulation & Abolition) Act 1970 and Allied Rules, the contractor employing 20 or more labourers is required to obtain licence from the Inspector of Labour, Vellore. This licence shall be amended and / or renewed whenever there is an increase in the workmen employed by him or in the event of contract being extended or renewed. The contractor shall inform the Licence Number so obtained to the Human Resources Department.

20. The Contractor shall maintain the following Registers and Records and make them available for inspection at any time. (The list is only for example, but not exhaustive).

A	Form XII	Register of contractors
B	Form XIII	Register of workmen employed by contractor (Rule 75)
C	Form XIV	Employment card issued by contractor (Rule 76)
D	Form XVI	Muster Roll (Rule 78 (1) (a) (i))
E	Form XVII	Register of wages (Rule 78 (1) (a) (i))
F	Form XVIII	Register of wages – cum Muster Roll (in case of weekly payment)
G	Form XIX	Wage Slip (Rule 78) (b)
H	Form XX	Register of deduction for damages of loss (Rule 78) (1) (a) (ii)
A	Form XXI	Register of files (Rule 78 (1) (a) (ii)
B	Form XXII	Register of advances (Rule 78) (1) (a) (ii)
C	Form XXIII	Register of overtime (Rule 78) (1) (a) (iii)
D	Form XXIV	Return to be sent by the contractor to licencing officer (Rule 82) (1)

21. In case a contract labourer meets with an accident while on duty, the contractor shall immediately intimate the information to Safety Department, Contracting Agency and Human Resources Department and submit the Accident Report duly filled in all respect and sent a copy to ESI local office. ESI dispensary and Inspector of Factories(for major accidents) with in 24 hours of accident through Safety and Human Resources Departments. All assistance for the injured workman such as to taking him to ESI Dispensary; for treatment must be rendered by the contractor.

22. Compliance of the above provisions does not absolve the obligation of contractor arising out of other statutory obligations.

23. Employment of child labour is strictly prohibited.

24. Payment of Bonus: In respect of work done by the labour, the contractor has to pay to his labourers as laid down by the Payment of Bonus Act – 1965.

25. The contractor shall fully comply with the following enactments:

- a) Contract Labour (R & A) Act, 1970 and rules formed there under in TamilNadu state.
- b) Wage Rates not less than that notified by State Labour Department from time to time.
- c) Payment of Wages Act.
- d) ESI Act, 1948
- e) EPF Act, 1952
- f) Workmen's Compensation Act, 1923.
- g) BHEL instructions as issued from time to time in regard to working hours, holidays, or any other statutory provision.



Enquiry Number: 664087E

Dt.10.01.2015

SECTION IV

GENERAL TERMS & CONDITIONS OF THE TENDER

Before preparing the offer, vendors are requested to go through the following details carefully

A] Eligibility Criteria for Vendors

Firms located within Tamilnadu who are having experience in Steel Fabrication, working inside factory premises of Government/PSU organization for a minimum period of 2 years are eligible to quote for this tender.

i) New Firm (So far not Registered with BHEL, Ranipet as Outsourcing Vendor)

New vendors are eligible to quote, subject to meeting eligibility criteria (w.r.t. the Facilities, man-power, Financial stability, experience in completing similar/same job earlier) by supporting with relevant documents.

Experience: wherever experience is called for, the documentary proof for having experience, duly attested by notary public shall be enclosed with the tender. Vendor should submit the 2 recent Job-Work-Order copies executed by them within three years of tender due date along with performance certificate / end user certificate as a proof. All credentials will be verified by BHEL.

Filled-in Vendor Registration form as in Annexure-K is mandatory for all new firms. For accessing the tender documents in online through internet, the new vendors will be directed to enter to a web-site for new vendor registration. After filling up of the data in the web-site, Vendor will be provided with the BHEL-reference-Code Number, which shall be mentioned in the offer wherever Vendor Code is called for.

BHEL registered Vendors (Other BHEL units) : Vendors registered with any unit of BHEL for the similar jobs , shall give details of their registration along with the category registered for. Such Vendors also treated as new vendors for evaluation purpose.

ii) Existing Firm (Registered with BHEL, Ranipet as Outsourcing Vendor having Vendor Code)

Firms already registered with Outsourcing (OS) BHEL/BAP/Ranipet for this job and existing vendors who are executing the contract in the past years shall be directly qualified.

Firms already registered with Outsourcing for general fabrication also can quote subject to meeting the eligibility criteria specified above and they will be treated as new vendors for evaluation purpose.

B] Vendors Not Eligible to Quote

Vendors declared / notified as defaulters / poor performers on quality / delivery grounds are not eligible to quote . The vendors with whom the material shortages were found during stock verification and not settled at the time of tender opening will not be considered. Offers if any received such vendors shall not be considered.

Vendors under HOLD by BHEL and vendor delisted/banned are not eligible for whole tender.

C] Validity of Offer

Price validity shall be One Year from the date of finalisation of Annual Rate Contract; however the validity date of the offer is 180 days from the date of tender opening for ordering. (Note: If Supplier does not honour his own offer or any of its conditions within the validity period, penal action deemed fit as per **Suspension of Business Dealings with vendors.**



D] Submission of Offer

Before tendering, the tenderers are advised to inspect the site of work and its environments and be well acquainted with actual working and other prevalent conditions, position of materials. Instructions to tenderers, drawings, specifications and other documents also form part of the agreement to be entered into.

Note: Vendor has to quote for all items. Offers for partial items/quantity are not acceptable and will be summarily rejected.

TENDERS

The Bids shall be submitted in Two Parts namely (i) Techno Commercial Bid and (ii) Price bid cover. All these Two covers should be sealed individually and to be put in a single envelope.

Sealed tenders super-scribed with Tender Number with date, Due Date, Steel Box ARC 2015-16 & Supplier's Name, Vendor Code/Reference Code shall be addressed to

**Manager / Contracts,
Outsourcing Department,
Bharat Heavy Electricals Limited,
Ranipet – 632 406, Tamilnadu,**

so as to reach him on or before the date and time specified in the tender.

The bidders are requested to submit the bids with double stapled on the left middle of the papers, and tied with file tag. Bidders are also advised strictly not to submit the bids with spiral binding & hard book binding, as it will hamper the evaluation of the offers.

The details of contents of the offer covers are as under:-

Cover I: Techno Commercial Offer:

Sealed Cover super-scribed "Cover I – Techno Commercial Offer" with Steel Box ARC 2015-16, Tender Number & Date, Vendor's Name & Vendor Code / Reference Code containing:

- a) **Check list for Cover-I given as Annexure-A**
- b) **Techno Commercial Offer given as Annexure-B**
- c) **Scope of Work confirmation given as Annexure-D**
- d) **MSME / SSI documents** if any

Note:

- (i) Cover I received without the Documents as specified above will lead to rejection of the offer.
- (ii) The Cover II of such offerors shall not be opened and they would not be eligible to participate in the tender further.

e) Documents to be enclosed for Partnership Firm – Copies Attested by the Notary Public

- i) Latest Form- A, issued after 01.04.2014.
- ii) Partnership Deed Copy (AT WILL).

f) Documents to be enclosed for Limited Firm (Private Firm) – Copies Attested by the Notary Public

- i) Latest resolution by Board of Directors.
- ii) Memorandum of Article of Association.
- iii) Company's Affidavit for existence



iv) Latest Annual Report.

v) Directors Share details

g) **Vendor Registration Form** given as **Annexure-K** along with all necessary documents **(For New Firm)**

h) **Experience** - Documentary proof for having experience, duly attested by notary public **(For New firm)**

Note:

(i) All new firms submitting the offer shall be subjected to assessment of vendor registration forms **(Annexure-K)** along with supporting documents for considering their offer. Price bids of firms failing to meet the Technical Qualification / Eligibility Criteria of the quoted vendors shall not be considered for further processing in the tender.

(ii) Offers shall be submitted along with PAN No., CST & TIN No. / Tariff No. etc, failing which BHEL will not be liable for payment. Our TIN No. 33243560005, CST No. 239383/11.06.91, BHEL ECC No. AAACB4146PXM008.

(iii) Money values shall not be indicated anywhere in the Technical Bid.

(iv) All Annexure to the Techno-Commercial bid should be serially numbered.

(v) Tenders not submitted in the prescribed formats given in the Annexures and *incomplete offers* are liable for rejection.

vi) Documents shall be annexed in the order specified above.

Cover-II : Price Bid

Sealed Cover super-scribed "Cover II – Price Bid" with Steel Box ARC-2015-16, Tender Number & Date, Vendor's Name & Vendor Code / Reference Code containing:

Price Bid - Price duly filled-in the Price Bid format provided in the tender document as **Annexure-C** for each item in conformance with the commercial terms as per Cover-I.

The Prices shall be indicated in both figures and words. Unit rate only to be mentioned in the price bid.

Any Rates indicated other than in Price Bid cover II shall not be considered.

Note:

i) Rates quoted shall be Firm throughout the contract period including total extended period if any. No price escalation/variations shall be entertained during the ARC period on any account. The rates are operative for placement of orders for **ONE YEAR** on Rate Contract basis to be entered into between BHEL and the Contractor.

ii) While quoting their rates, the Bidders are advised to take into account the likely expenditure, escalations, statutory requirements & levies, labour laws, safety requirements, taxes ,etc during the operation of Rate Contract for one year from the date of award of Contract.

iii) Rates quoted shall include all royalties, terminal taxes, octroi, central and provincial excise duty, sales tax and other taxes and duties leviable under the state and central government rules, except Service Tax. Bharat Heavy Electricals Limited (BHEL) will not entertain any claim whatsoever in this respect.

iv) **The tenderer shall not include Service Tax in their quoted rates.** Service Tax as applicable to this contract will be reimbursed by BHEL. The successful tenderer shall register themselves with the service tax authority and pay separately the Service Tax as applicable to this contract during execution of the work and



get it reimbursed at actual by BHEL by submitting necessary documentary proof, in Original, as required by BHEL.

v) The quoted rates shall include expenditures towards complying statutory payments like Provident fund, ESI payments, bonus etc for the labours & staff deployed in the work.

vi) The quoted rates shall also include expenditure towards consumables like Oxygen and Acetylene required for welding, arrangement of internal transport for movement of materials within factory premises and any other consumables required for day to day operation, which are all wrest with Vendor's scope. (Providing of Open Yard-Space, Power supply and Consumables Restricting to Compressed Air, Welding Electrode and Paints are to be supplied by BHEL)

vii) Tenderer shall bear all cost incidentals to preparation, submission and negotiations of the tender.

viii) If BHEL withdraws the Tender before or after the receipt of offers, whether the offer is accepted or not, tenderer shall not be entitled to claim any costs, charges, expenses incidental or incurred by him through or in connection with the submission of the offer.

ix) In case, there is a discrepancy in the term quoted in techno-commercial bid and price bid, the term as per the techno-commercial bid (Cover I) shall hold good and the commercial term quoted in the Price Bid (Cover II) shall not be considered.

x) In their own interest, all Tenderers are advised to double check their prices before submitting the offer.

xi) The quotation should be valid at least for a period of 180 days from the tender opening date.

xii) Offers should be submitted One Set in original only.

xiii) The offers should invariably contain Signature (ink-signed) & Office Stamp of the Supplier. Any corrections / erasures in the offers should be initialled and stamped.

xiv) Bidders should submit the prices in Indian Rupees only.

xv) Unit rates should be quoted in figures as well as in words with reference to each item and for all the items shown in the attached schedule.

E] Persons Authorized for Signing the Offers:

The Tender documents shall be signed by the Authorized Signatory Only.

Proprietary Firm: In case of Single Ownership / Proprietorship establishment, the Tender shall be signed by the Owner / Proprietor Only.

Partnership Firm: In case the Bidder is a Partnership Firm under Partnership Act, the Tender shall be signed by all the Partners of the firm or by the Managing Partner who have Signature and Seal of the Firm authorized to do so **OR** by a person holding the Power of Attorney on behalf of the Partnership Firm. Power of Attorney attested by a Public Notary shall accompany the Techno-Commercial-Bid. Power of Attorney shall be submitted as per format given as **Annexure J** only.

Private Firm: Authorized signatory shall be the person holding "power of attorney" on behalf of the firm/company/Bidder-concerned and authorized/empowered by MD or Board of Directors or owner of the firm, to act on behalf of the firm for quoting this Tender and all proceedings connected with, till finalization



and execution of the Contract. Power of Attorney attested by a Public Notary shall accompany the Techno-Commercial-Bid.

The Bharat Heavy Electricals Limited will not bound by any Power of Attorney granted by the tenderer or changes in the composition of the firm made subsequent to the execution of the contract. They may, however, recognize such power of attorney and changes after obtaining proper legal advice, the cost of which will be chargeable to the contractor concerned.

F] Opening of Offers

a) Tenders shall be received up to 14.00 Hours on the said due date and be opened on the same day at 14.30 Hours. Tenders received after 14.00 Hours would not be opened. The times indicated are Indian Standard Time (IST).

b) It is bidder's responsibility to ensure that the Tenders are submitted before the specified date and time. BHEL shall not be responsible for any postal delay.

c) If a Supplier submits only one envelope / cover containing all the bids or combined bids e.g. Techno Commercial Bid & price bid together, the bid is liable for rejection. The decision to accept such bids shall be the sole discretion of BHEL, which may be done by BHEL after segregating the bids so received.

d) First Cover I containing EMD / MSME documents and Techno Commercial bid shall be opened, only if EMD as mentioned above OR the valid MSME certificate and Techno Commercial bid is available, the bids will be evaluated to proceed further.

e) Price bids – Cover II of Technically qualified bidders alone shall be opened on a later date. The date / time of Price Bid opening will be communicated to the technically qualified Bidders separately.

f) Witnessing the Tender opening

i) Such of those Tenderers who wish so, may participate in the Tender Opening by deputing their representatives. The representatives would be allowed to participate in the Tender opening only on submission of a signed and stamped authorization letter issued by the Supplier. Representatives without the Authorization Letter would not be allowed to participate in the Tender Opening.

ii) Representatives who turn up after the Tender opening time / start of the Tender opening would not be allowed to participate. After tender opening the details would not be given to such suppliers who choose to be absent at the Tender opening.

iii) Authorizations received by fax / e-mail would not be acceptable.

iv) Details of the vendors participated alone would be read out during Technical Bid opening and details of Price alone would be read out during Price Bid opening by the Tender Opening Officer.

Note

(i) Bids including all enclosures and supporting documents shall be provided in ENGLISH language only.

(ii) Offers sent by e-mail / fax or any other mode other than the two cover system specified above shall be avoided. On an exceptional case offers may be e-mailed to tenderoutsourcing@bhelrpt.co.in .

(iii) At its option, BHEL may consider extending the due date/s for the tender openings. Sufficient notice would be given by BHEL for such extensions.



G] Evaluation of Techno Commercial Offers

- a) The eligibility of the firms will be verified based on the pre-qualification criteria of the tender and compliance / confirmation to the tender requirements. Only those firms complying with the pre-qualification criteria shall be considered for participation in the tender. Once the vendor is found to be technically suitable meeting all the technical and commercial requirements of BHEL, price bid of those qualified vendors only will be considered for further processing.
- b) Offers of vendors not technically qualified will be rejected and the same will be communicated to those vendors with reasons.
- c) No deviation or change from the Tender conditions will be allowed and BHEL reserves the right to reject such offers.

H] Evaluation of Price Bid

- i) The rates quoted shall be evaluated item wise on the basis of "Total cost to BHEL".
- ii) If the rates of Two vendors are equal resulting in same ranking, among the equal ranked vendors, the sub-ranking will be done to differentiate (a) to decide the L1-vendor eligible for negotiation and (b) to decide H1-vendor for elimination of higher ranked vendors.

The sub-ranking will be done in-the-order by providing lower ranking for vendors

- (1) Not having listed as defaulter,
 - (2) Become Sole-L1 for more number of items,
 - (3) Less count of Pending IPs for more than 30 days,
 - (4) Nearer to BHEL by location
 - (5) Draw of lots as a final measure (in presence of such vendors, who may like to be present).
- iii) Tenderer contacted in this tender does not automatically qualify for consideration just because they are found to be the lowest in Tender. BHEL reserves the right to reject any offers without assigning any reasons. BHEL also reserves the right to negotiate or counter offer the rates to any of the parties at their discretion.
- iv) If the L1 rate against any item is found not acceptable to BHEL, then the L1 firms may be called for negotiation before finalizing the rate.
- v) BHEL has the right to refloat or short-close the Tender if L1 price is not the lowest acceptable price, or for other reasons.
- vi) H1 vendor on overall ranking (Total Value) will be eliminated for all items from the tender irrespective of status of individual item. Negotiation will be made with L1 vendor only for individual item.**
- vii) The rates shall be quoted only in the Price Bid format given in the tender document, both in words and figures. Wherever there is a difference between the words and figures, the following guidelines will be followed.
- a) If there is a difference between unit price and the total price (which is obtained by multiplying the unit price by the quantity), the unit price shall prevail and the total price corrected accordingly, unless in the opinion of BHEL there is an obvious misplacement of decimal point in the unit price, in which case the total price as quoted shall govern and the unit price corrected accordingly.



- b) If there is an error in a total corresponding to the addition or subtraction of subtotals, the subtotals shall prevail and the total shall be corrected.
- c) If there is a discrepancy between word and figures, the amount in words shall prevail, unless the amount expressed in words is related to an arithmetic error, in which case the amount in figures shall prevail subject to (a) and (b) above.
- d) If there is such discrepancy in an offer, the same will be conveyed to the bidder with target date up to which the bidder has to send his acceptance on the above lines and if the bidder does not agree to the decision of BHEL, the bid is liable to be ignored.
- viii) All bidders shall submit their offers by filling-in the format of the BHEL tender documents. Offers received in any other format are liable to be rejected. Offers are asked in BHEL's format for purpose of standardisation - to help in the offer evaluation.
- ix) Offer with any pre-conditions (like conditional discounts) for price are liable for rejection.
- x) BHEL reserves the right to reject without assigning any reasons other than already specified for such offers having deviations to BHEL Specifications, Standard Terms & Conditions at its discretion. The decision of BHEL in this regard shall be final.
- xi) In case of any discrepancy between the description of the Items or quantities, specifications, drawings and for other tender documents, the decision of BHEL in writing is final, binding and conclusive for the purpose of this contract.
- xii) BHEL reserves the right to reject an offer due to unsatisfactory past performance during tender finalisation / execution of a contract at any of BHEL projects / units.
- xiii) BHEL reserves the right to conduct negotiations on the "Price" and "Other Commercial Terms and Conditions" with the lowest ranked offeror and
- xiv) If so required by BHEL, Supplier may have to share their cost data / costing sheet with BHEL.
- xvi) BHEL reserves the right to restrict the number of parties for award of contract.

I] Abnormally Low Offers

If the prices offered by L1 Bidders are found to be unrealistic, unworkable with respect to BHEL's estimate or prevailing market rates, BHEL will ask for justification also demand the break up cost element for such rates from the vendors with appropriate documentary evidence and if not submitted it will be construed that the vendor has offered the rates with an intention to sabotage BHEL Tender process/ tamper Tendering procedure, affecting the ARC process. In such cases, BHEL will have the discretion to reject the offer in line with BHEL procedures. Hence the bidders are advised to exercise abundant care in submitting a correct genuine offer.

J] Counter offer

- i) Once the L1 rates for the items finalized by BHEL, then the L1 rate shall be counter offered to the other technically qualified vendors for all the items for their acceptance.
- ii) ***The total number of sources required is Four, hence counter offering will be limited up to reach of four vendors only. For ordering purpose L1, L2, L3 and L4 vendor arrived based on overall ranking (Total Value) only will be considered. Ordering on L2 to L4 vendors will be done on countering offering of rate proposed for ordering on L1 vendor. Counter offer will be extended to vendors up to get four vendors acceptance. Offers of those vendors who accept finalized rates for all six items***



alone will be considered for ARC and Loading of jobs will be considered as per the split ratio but subject to their Delivery Performance.

- iii) Acceptance for partial items is not acceptable. If any vendor is not accepting BHEL's counter offer for the tendered items fully, they will be eliminated from the tender and no contract will be made with them.
- iv) Based on the acceptance of vendors, rate contract will be entered with vendors for the accepted rates.
- v) Counter offering will not be extended to top higher ranked (H1.etc.) eliminated vendors.
- vi) If none of the vendors are accepting for the counter offer given by BHEL, then BHEL will place orders on the L1 ranked vendor for the tentative quantity mentioned against each item subject to the capacity available with the vendor.

K] Placement of Orders and Loading

- a) Tentative quantity likely to be ordered against each item will be in the ratio of 35:30:20:15 for L1:L2:L3:L4 vendors. However after initial order, further loading will be made based on their performance irrespective of the ratio specified above. Tender quantity may increase/decrease during the rate contract period. BHEL does not guarantee any minimum load for any vendor.
- b) The contract is to be signed in Rs.100/- stamp paper. Hence after getting a confirmation on signing of contract, vendor shall get a stamp-paper for a value of Rs. 100/- and submit to BHEL for contract preparation.
- c) After finalization of tender, if the Contractor is awarded the Contract, Proprietor, Partners and Directors (as applicable) should physically present themselves and sign the contract in the presence of Head of OS Department with in the dates specified.
- d) Orders would be placed as Addenda's on the Annual Rate Contract signed by the vendors.
- e) Loading priority will be given among the L1,L2,L3 vendors who have signed the Annual Rate Contract, in the order of original ranking (i.e. from L1 ranked vendor) subject to the capacity availability, Quality and delivery performance.
- f) If none of the vendors are accepting for the counter offer given by BHEL, then BHEL will place orders on the L1 ranked vendor for the tentative quantity mentioned against each item subject to the capacity availability with the vendor.
- g) The total available load from time to time will be distributed to those Contractors with preference to L1, L2 and L3, with whom Contract is entered into and to that Contract, the addenda shall be placed in a phased manner subject to the availability of potential for BHEL and also depending upon vendor performance such as collection of Raw materials in time, manufacture according to BHEL plans/requirements, meeting quality requirements, prompt returning & accountal of balance materials and also the minimum required facilities available at the Contractor's works to meet the job requirements and submission of other reports as called for, then and there.
- h) Purchase orders will be issued after entering into Rate contract with the Contractors. Discrepancy in the PO's if any, has to be settled immediately then and there within 10 days from the date of release of PO.
- i) The contractor's responsibility for this contract shall commence from the date of issue of order acceptance for this tender. The scheduled period of contract will be for one year and the contractor will have to plan this work accordingly.



L] Bank Guarantee

1. Contractor whose tender is accepted, shall sign the contract, makes necessary **Bank Guarantee** Rs.50,000 It is also to be noted that the BG for the value indicated shall be made available with BHEL at the time of entering into ARC, failing which Firm will not be considered., and BHEL reserves the right to cancel the contract and initiate alternate action at the Cost & Risk of such tenderer.

2. **Bank Guarantee Norms** : Bank Guarantee may be furnished in any one of the following forms:

20.1 The Contractor shall execute a Bank Guarantee for value of Rs 50000/- from any one of the Scheduled or Nationalized banks on behalf the Contractor for the safe custody of the materials supplied by the BHEL, Ranipet as free issue and for the satisfactory performance of the Contracts. The guarantee shall be executed on a non-judicial stamp paper or value Rs. 100/- as per our standard Bank Guarantee clauses and shall be kept valid for the full contract period & Claim period of additional THREE MONTHS over the contract period and extensible till final settlement of supply and payment and BG to be submitted directly by Bankers to BHEL. The Bank Guarantee should cover the recoveries to be made by BHEL towards Safe custody of Material Supplied , Scrap / Faulty workmanship, etc. also for which proper material accountal is not made within the stipulated time and shall cover all Contracts past, present and future placed / to be placed by the BHEL, Ranipet.

20.2) Necessary Bank Guarantee(BG) / Fixed Deposit Receipt(FDR) should be furnished. The BG shall be kept valid through out the contract period PLUS 3 Months as claim period and must be renewed in-time. It is also to be noted that the BG for the value indicated for each Firm shall be made available with BHEL at the time of entering into ARC, failing which Firm will not be considered.

20.3) The release of Contract by BHEL, Ranipet shall be on the strength of Bank Guarantee for the safe custody of raw materials issued by BHEL, Ranipet as free issue in line with CL. 21.1. BHEL reserves the right to increase the value of BG/FDR depending on the material availability with the contractors from time to time.

M] Risk Purchase

Alternatively, the BHEL at his option will be entitled the contract and to manufacture elsewhere at the risk and cost of the seller either the whole of the goods or any part which the supplier has failed to deliver or dispatch within the time stipulated as aforesaid or if the same were not available, the best and the nearest available substitute therefor. The supplier shall be liable for any loss which the BHEL may sustain by reason of such risk purchases in addition to penalty at the rate mentioned in LD clause.

In case those vendors do not execute the orders, BHEL may get the job done through other sources at the Risk and cost of those vendors and the extra expenditure involved shall be recovered from these vendors from any amount due to them.

N] Liquidated Damages:

BHEL will levy penalty as Liquidated Damages (LD), for delay in delivery. The damages shall be at the rate of ½% per week or part thereof subject to a maximum of 10%. Delivery for purpose of L.D, will be reckoned as the date of clearance of the items for dispatch by BHEL. Supplier should quote a definite delivery period and any delay in delivery will attract penalty.

The delivery period includes time involved in material collection, cutting plan approval, collection of further materials if any and handing over of the finished goods to BHEL-Shipping. Finished goods items shall be door delivered at Shipping/Stores inside the factory, BHEL, Ranipet.



O] Termination of Inquiry / Orders:

- a) BHEL reserves the right to cancel any inquiry before opening of the tender, without assigning any reason.
- b) BHEL reserves the right to cancel any tender and refloat a fresh tender, at any time after opening of the tender, in case it finds the response to its tender as not meeting its requirement. This shall be at the sole discretion of BHEL.
- c) In the event of non-performance of the contract by the Supplier, BHEL reserves the right to cancel the order with issue of a written notice. BHEL would provide a curing period of 30 days, for the Supplier to rectify the situation. If the Supplier fails to rectify the reason/s that led to the issue of cancellation notice by BHEL, then the cancellation order would be issued automatically by BHEL, without further recourse to the Seller. BHEL will not pay any cancellation charges or any other charges / damages to the Supplier, arising out such cancellation.
- d) In the event of the non-performance of the contract, by the Supplier, the rights of BHEL include, in addition to cancelling the order, to take alternate action at the cost and risk of the supplier. The additional expenditure to be incurred by BHEL in such alternate action would be to the account of the supplier.
- e) BHEL reserves the right to cancel the order for delay in supply beyond penalty period without any monetary or legal obligations and at the risk and cost of the Supplier. and
- f) BHEL will levy penalty as Liquidated Damages (LD), for delay in delivery. The damages shall be at the rate of ½% per week or part thereof subject to a maximum of 10%. Delivery for purpose of L.D, will be reckoned as the date of clearance of the equipment for dispatch by BHEL.

P] Force Majeure

- i) If at any time during the currency of this contract, the performance in whole or in part, by either party of any obligations under this contract shall be prevented or delayed by reason, of any war, hostilities, acts of the public enemy, civil commotion, sabotage, fires, explosions, epidemics, quarantine, restrictions or acts of GOD (hereinafter referred to as events), then provided notice of happening of any such events is given by either party to other within ten days from the date of occurrence thereof, neither party shall reason of such events be entitled to terminate this contract nor shall either party have any such non performance and delay is resumed as soon as practicable after such events has come to an end or ceased to exist. If the performance in whole or part of any obligation under this contract is prevented or delayed by reason or any such event claims for extension of time shall be granted for period considered reasonable by the purchaser subject to prompt notification by the seller to the purchaser of the particulars of the events and supply to the purchaser if required of any supporting evidence. Any waiver of time in respect of partial installment shall not be deemed to be a waiver of time in respect of remaining deliveries.
- ii) If as a result of difficulty in procurement of raw materials or due to force majeure reasons or any other reasons what-so-ever the contractor is unable to keep the delivery schedule of the contractee, extension of time may be granted by the contractee at their discretion as may be necessary to the extent considered necessary should there be delay in supply beyond the extended date of delivery, it shall be open to the contractee to terminate the contract in part or full and make other arrangements for executing fabrication elsewhere at the cost and risk of the contractor.

Q] Others

- a) The Firms are advised to study and understand the scope of work and the entire process of Contract execution involved before quoting. Any technical clarifications required can be sought in person or by e-mail one week before the due date of Tender opening.



- b) In case of any contradiction in the terms and conditions given here and elsewhere in the other documents of the tender or any omissions in the Tender documents or for any clarifications in the tender conditions, it shall be the responsibility of the tenderer to get it clarified from BHEL. The officer authorized to provide such clarifications is the Manager / Contracts, Outsourcing Department, Phone: 04172 – 284030, e-mail mkmoorthy@bhelrpt.co.in, rvr@bhelrpt.co.in, ssvasan@bhelrpt.co.in
- c) Alterations to the conditions of the Tender can be done only by the authorized officer, at any time before the date and time of tender opening. Such changes, if any, would be communicated in writing and / or hosted in the web-page.
- d) BHEL will conclude that the offer has been submitted by the firm fully understanding all the requirements both explicit and implied and other conditions and accepting the same. After tender opening, the bidders are not allowed to change / alter any of the conditions either partly or fully. Offers of any such firms doing so, will be rejected.
- e) Conditional and late Tenders, Tenders which are incomplete or otherwise considered defective with respect to Tender conditions and Tenders not in accordance with the Tender conditions herein contained and the Tenders not in original shall be rejected out rightly, at any point of time during the Tender processing.
- f) Should the tenderer or the contractor have a relation or relations in the case of a firm or company of contractors, one or more of its shareholders or relations or relations of the share holders employed in BHEL or any ex-employee who has retired / resigned within a period of two years as on date of quotations or at any subsequent date after the award of the contract, the authority inviting the Tender shall be informed of the fact at the time of submission of the tender and there after as applicable and obtain the clearance of BHEL for such engagement failing which, BHEL may in its own discretion reject the tender or rescind the contract.
- g) If a Bidder is found to have given false information / documents as a part of their offer, such offers shall be rejected / the contract shall be terminated and the firm shall be banned from getting business from all BHEL units.
- h) If any Supplier attempts to bribe, or pay commission, gift or any advantage or bring in undue influence either by himself or on his behalf any one including a stranger to the tender, in addition to instituting legal proceedings as per the extant laws prevailing, will disqualify the supplier from this tender and all future tenders of BHEL. Decision of the Purchaser would be final in this matter.
- i) The laws governing this transaction shall be the laws in India.
- j) The tenderer shall acquaint himself with the conditions/limitations and official regulations under which or conforming to which the jobs are to be performed and shall examine carefully at the information as may be furnished to them in writing from time to time.
- k) The tenderer shall acquaint himself with applicable Acts.
- l) As a policy BHEL is not registering any power of attorney issued by Contractors/Contractors in favour of their bank for the collection of Invoice amounts on behalf of Contractors/Contractors and merely because BHEL had acted upon any such request by the party or their bankers does not constitute any legal right or binding on BHEL for any acts of omissions and commissions or failure to act upon it or for any payment made directly to the party. If any banker includes BHEL also as a party to any such dispute between the banker and the party, all legal and incidental expenses thereof will be recovered from the concerned parties only.
- m) In the event of an order, Supplier shall agree to settlement of disputes or differences, if any, by way of arbitration, in accordance with the “Rule of Arbitration” of the Indian Council of Arbitration.



n) The offer/s of such of those bidders who do not accept for levy of liquidated damages (LD) for delay in delivery and who do not accept for submission of the BG for the value and period specified herein above is likely to be summarily rejected. No correspondence would be entertained by BHEL in this regard, on this subject. BHEL specifically draws the need of this mandatory requirement to the notice of all Bidders. The Price Bid of such of those offerors failing to meet this requirement would not be considered for the Price-Bid Opening.

o) The language in the tender downloaded by the Bidders shall at no point of time be changed, altered or modified in any manner by the Tenderer. If such changes are made by any tenderer, it shall be considered as tampering with BHEL's specifications and the offer shall be summarily rejected, whenever it is noticed by BHEL. Such Bidders would be disqualified from the Bidding Process and their offers would be forfeited / Bank Guarantees invoked. They would not be allowed to participate in future tenders of BHEL.

p) If a tenderer expires after submission of his tender, BHEL may be at the discretion cancel such tender. If a partner of a firm expires after submission of the tender or after the acceptance of the tender, Bharat Heavy Electricals Limited may cancel such tender at the discretion unless the firm retains the character.

q) All tender conditions shall be deemed to form an integral part of contract for the work to be entered into.

r) Payment will be made through e-payment only. Contractor has to submit the EFT form after signing the contract for making payment.

R] General :

1.0 Definitions : Throughout these conditions and in the specifications the terms :

(a) **"The Contractee"** means the Bharat Heavy Electricals Limited, acting through the Additional General Manager, Outsourcing Department ,Boiler Auxiliaries Plant, Ranipet – 632 406 unless the context otherwise provides.

(b) **"The Contractor"** means the person, firm or company with whom the order for machining / fabrication is placed and shall be deemed to include the Contractor's successor (approved by the Contractee), representatives, heirs, executors and administrators, as the case may be, unless excluded by the terms of the Contract.

(c) **"The Drawings"** means the drawings exhibited or provided for the guidance of the Contractor.

2.0 Execution :

The whole contract is to be executed in the most approved substantial and workman like manner to the entire satisfaction of the contractee, or the inspecting officer, who shall have power to reject any of the fabrication of which he may disapprove; and his decision thereon and on any question as to the true intent and meaning of the specifications of drawings or of the work necessary for the proper completion of the contract, shall be final and conclusive. The contractee may require alterations if any to be made during the progress of machining /fabrication, and should these alterations be such that either partly to the contract considers an alteration in the changes justified such alteration shall not be carried out until amended cost of machining /fabrication charges have been submitted by contractor and accepted to fabricate without obtaining the consent of the contractee in writing to an amended cost of machining /fabrication charges, the contractor shall be deemed to have agreed to execute fabrication at such charges as may be considered reasonable by the contractee.

3.0 Interpretation :

Any dispute or difference of opinion in respect of the interpretation, effect or application of this particular condition of the contract or of the amount recoverable here under from the contractor shall be decided by the contractee and the decision shall be final and conclusive.



4.0 Book Examination Clause :

(a) The contractor shall, whenever required, produce or cause to be produced for examination by any officer of the contractee authorized in that behalf any cost or other account book or account voucher, receipt letter, memorandum, paper or writing or any copy of extract from any such document and also furnish information and returns verified in such a manner as may be required in any way relating to the execution of this contract or relevant for verifying, ascertaining, the cost of execution of this contract (the decision of such officer of the contractee on this question or relevancy of any document, information or return being final and binding on the parties). The obligation imposed by this clause is without prejudice to the obligation of the contract/Job-Work-Order or under any statutory rules or orders binding the contractor.

(b) The contractor shall, if the authorized officer of the contractee so requires (whether before or after the prices have been finally fixed), afford facilities to the officer of the contractee concerned to visit the contractor's works for the purpose of examining the process of manufacture and estimate of ascertaining the cost of production of the articles. If any portion of the work be carried out by a Contractor or any subsidiary or an allied firm or company, the authorized officer of the contractee shall have power to secure the books of such Contractor or any subsidiary or an allied firm or company shall be open to this inspection.

5.0 Set – Off Clauses :

Payment shall be subject to the deduction of any amount, for which the contractor is liable under this contract, or any contract in respect of which Bharat Heavy Electricals Limited, Ranipet 632 406, Tamilnadu is the Contractor.

6.0 Laws Governing the Contract :

(a) The contract shall be governed by the laws of Government of India in force.

(b) Irrespective of the place of execution of the contract, place of delivery, place of payment under the contract, the contract shall be deemed to have been made at Ranipet.

7.0 The Global Compact :

Global compact is a signature initiative of United Nations Security General and four United Nation Agencies

- Office of the High Commissioner for Human rights
- International Labour Organization
- United Nations Environment Programme
- United Nations Development programme

This is a board based initiative and engages:

- Individual Companies
- Business Associations
- International Labour
- Human Rights, Environment and development Organisations
- Academic & Public Policy Instructions and United Nations

The Contractee (BHEL) is a member of this Global Compact. As a participating Company, We have the obligation to

- ** Support and respect Human rights with in our spheres of influence.
- ** Make sure we are not complicit in Human right abuses.
- ** Make sure we are not employing forced or compulsory labour.



- ** Refrain from employing child labour
- ** Eliminate discrimination in our hiring and firing policies
- ** Support a precautionary approach to Health, Safety of employees and society and environmental challenges.
- ** Undertake initiatives to promote greater environmental responsibility
- ** Encourage development and diffusion of environmentally friendly technologies.

Contractor shall also ensure to fall in line with the above principles.

8.0 Occupational Health and Safety Management System (OHSAS 18001) and Environmental Management System (EMS 14001)

BHEL/BAP/RANIPET got accreditation Occupational Health and Safety Management System (OHSAS 18001) and Environmental Management System (EMS 14001). As per this, OS Contractors are requested to meet the requirements of EHS (Environmental Health & Safety) guidelines (mentioned below), while engaging and using Vehicles for incoming/outgoing transportation.

- To have valid Driving licence and RC book for the Transports
- To load the vehicle/bullock cart within the Safe Working Load (S.W.L.) The S.W.L. is to be displayed/painted on the vehicle/bullock cart.
- To load the material in such a way that it should not project outside the dimensions of the Vehicle/bullock cart.
- To stack the material in a manner that the material should not slide/fall during transportation.
- During manual lifting with an Adult, the weight should not exceed 50 kg.
- To attempt to adopt OHSAS 18001 / ISO 14001 requirements in their manufacturing process at Contractor's work place.
- To comply with applicable provisions of the Central Motor Vehicles Rules 1989 (Rule:136 and if any). List of important Phone Nos: (given by OS) should be available with the driver while transporting BHEL materials.
- To train drivers to handle emergency situation during transportation.
- To follow the Various Acts/Rules and Regulations (particularity Factories Act 1948 and Tamil Nadu Factory Rules 1950) applicable to them.
- To maintain valid PUC (Pollution Under Control) certificates and produce while vehicle is in this company premises.

Contractors are requested to meet the requirements of OHSAS 18001 / ISO 14001 as given below:

- ** To adopt OHSAS 18001 / ISO 14001 requirements in their manufacturing process at Contractor's work place.
- ** To comply with applicable provisions of the Central Motor Vehicles Rules 1989 (Rule: 136 and if any).
- ** To follow the applicable Acts/Rules and Regulations (like Factories Act 1948 and Tamil Nadu Factory Rules – 1950) applicable to them.
- ** In addition to this, they should follow the day to day communication of OS on this regard.



Enquiry Number: 664087E

Dt.10.01.2015

SECTION - V

SAFETY CONDITIONS

1. Safety & Security of all Men, material & Equipments at the yard/manufacturing site are the responsibility of the contractor.
2. Wherever any area declared dangerous, the contractor shall not allow his workers to work until a written clearance is obtained from appropriate authorities.
3. Whenever people work at height more than six feet, necessary platform and safety belts shall be provided for workers by the contractors to avoid fall from the height
4. No material of any kind shall be dropped or allowed to be dropped from any height.
5. Defective ladders shall not be used at all.
6. Inflammable materials shall not be stored near places where the sparks are likely to occur.
7. The necessary safety shoe and safety equipments such as gloves, safety goggles, helmet, safety belts etc must be issued to the workmen and strictly to be used while carrying-out the work.
8. If the contractor's workmen are found to violate the safety precautions punitive action will be taken by withholding a sum of Rs.500/- to Rs.1,000/- from the contractor bill for each violation.
9. The working area shall be kept clean by avoiding accumulation of metal scraps, debris and other unwanted material and free from all obstructions. Raw material are to be properly stacked at the yard
10. All temporary electrical connections shall be property earthed, insulated and periodically checked.
11. The contractor should arrange **WORKMEN COMPENSATION / INSURANCE POLICY** covered for all his workmen. A copy of the policy has to be submitted before commencement of work.
12. All safety precautions are to be taken by the contractor at their cost.
13. These safety measures shall be deemed to form an integral part of the Work order / Agreement.

ALL DIMENSIONS ARE IN MILLIMETRES

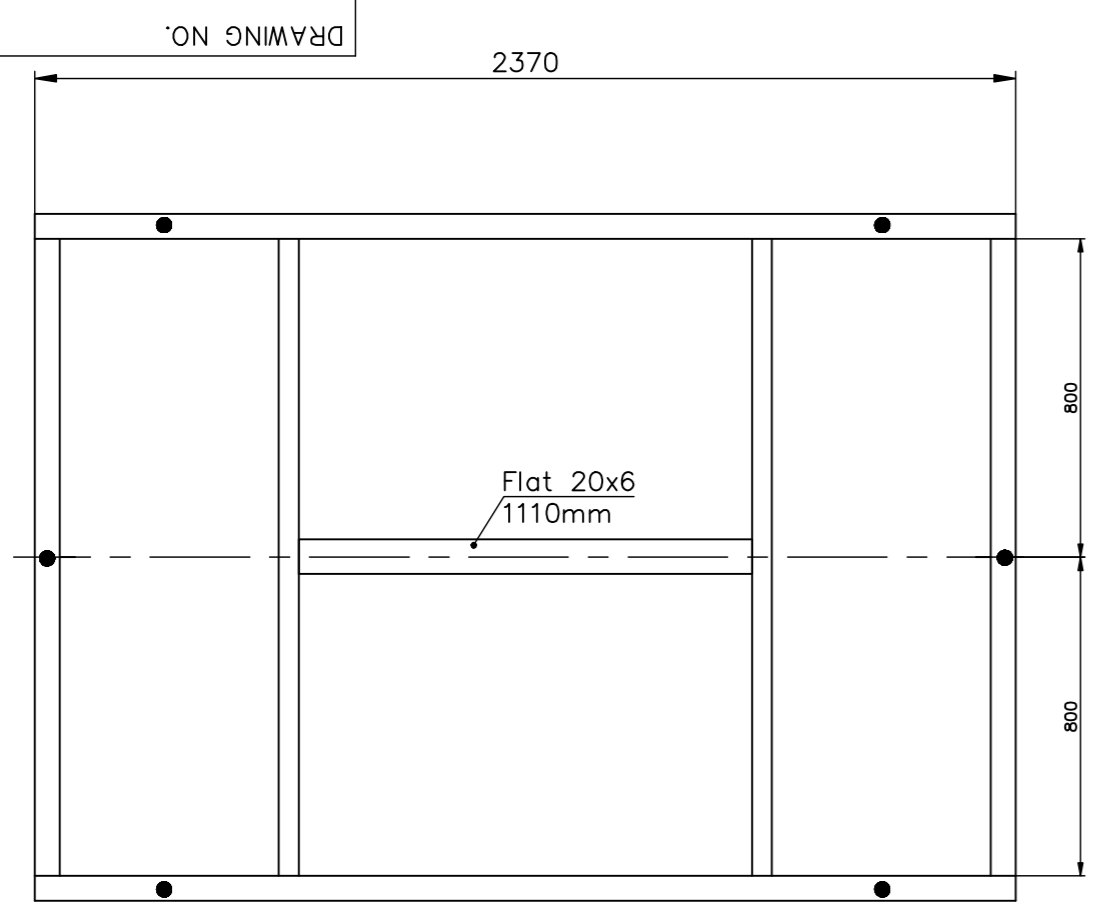

TOP VIEW

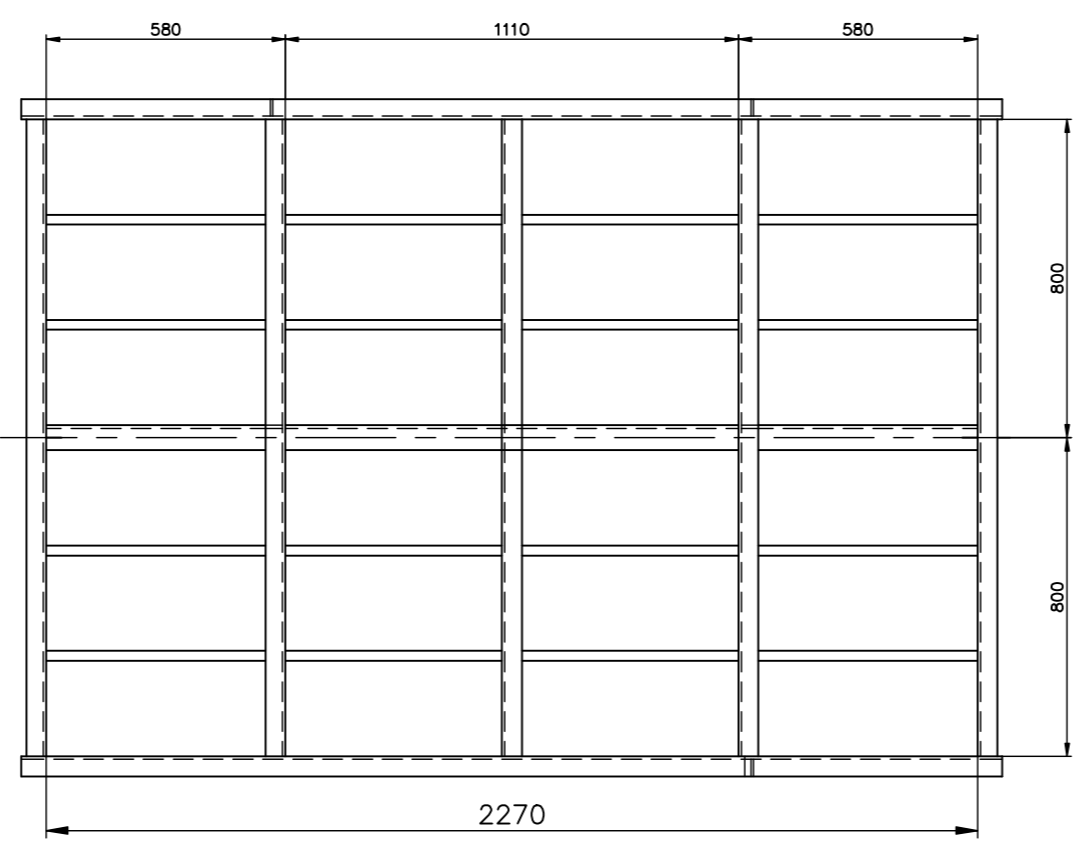

BOTTOM VIEW

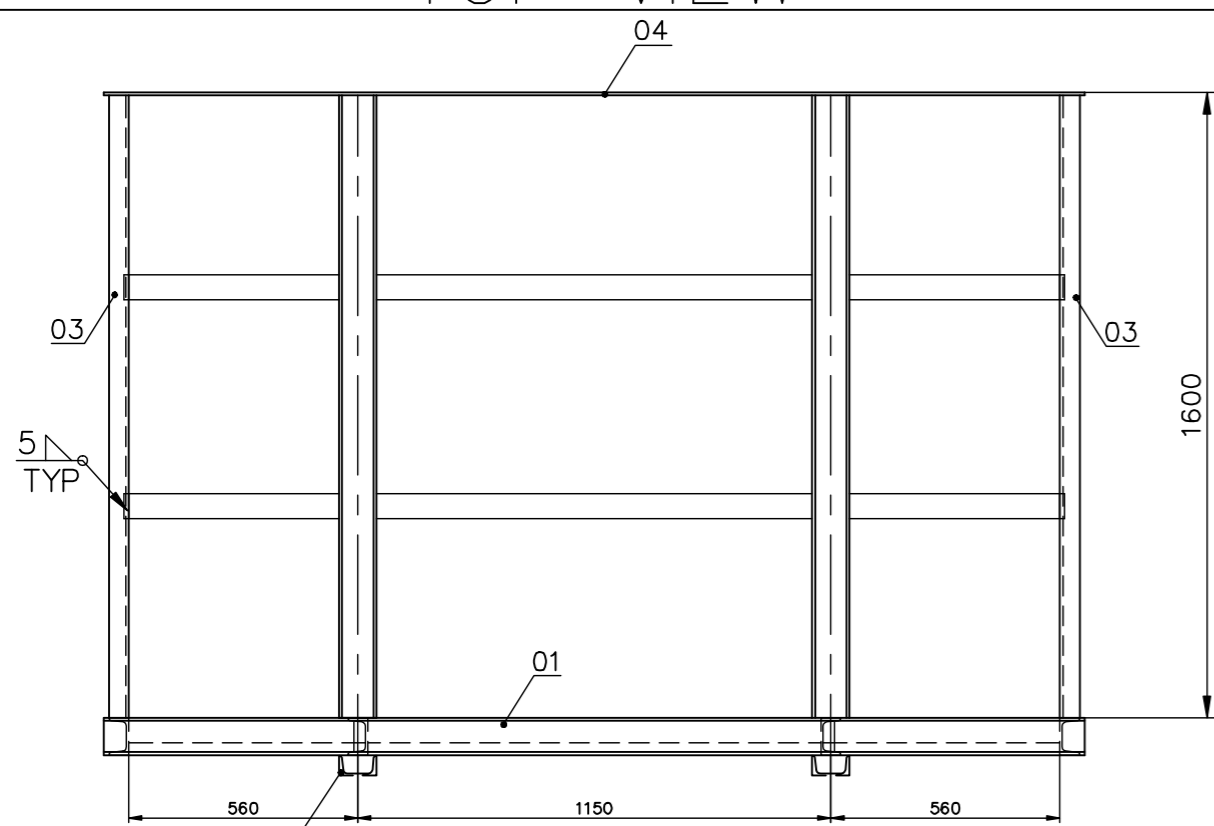

FRONT VIEW

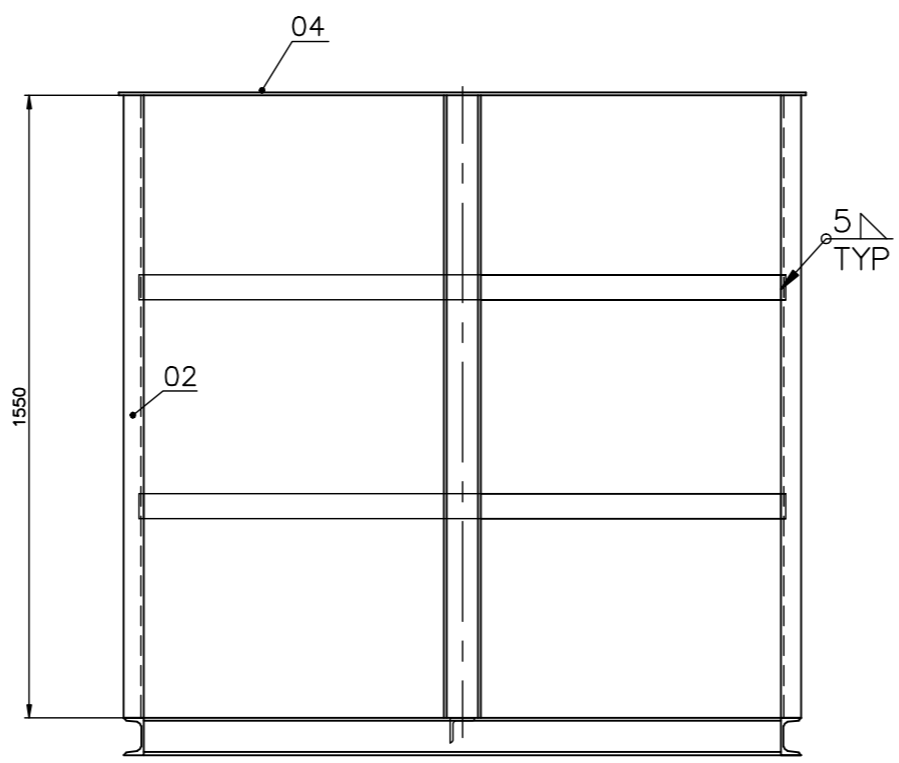

NOTES:

- 01. ALL BOX OPENING SHALL BE CLOSED USING ITEM-04.
- 02. TOP FRAME SHALL BE TACK WELD AT VENDOR WORKS TO ENABLE SHIPPING TO OPEN AND USE.
- 03. ONE COAT OF RED OXIDE PAINT IS TO BE APPLIED, TO AVOID RUSTING.
- 04. WELD 2d WHEREVER NOT SHOWN.
- 05. ITEMS USED ISMC75 SHALL BE SUBSTITUED WITH MATERIALS ON HIGHER SIDE ONLY.
- 06. LOAD CARRYING CAPACITY: 4500Kgs.

VARIANT NO	ITEM NO	DESCRIPTION	STD	DRAWING NO.	ITEM NO	MATL. CODE	A	UNIT	UNIT WT.	CS	ZONE
					VAR NO	MATL. SPEC	C	DI	QUANTITY		
	07	HEX NUT M10 PL- 6x35x40				4130400010 IS: 1363		NO	0.003 10		
	06	Screw & Nut M10X25 TUBE D60.8x4.5-200				4125510025 IS: 1363		NO	0.038 10		
	05	SH 0.63mm/ CE RANDOM SHEET				15-911-7150100 IS: 513 DD		SM	105.264 2.397 4.946 16.32		
	04	TOP FRAME		3-79-000-01449				NO	47.270 27.280		
	03	SIDE FRAME		3-79-000-01448				NO	32.154 14.081		
	02	FRONT FRAME		3-79-000-01447				NO	31.703 26.128		
	01	BOTTOM FRAME		3-79-000-01446				NO	114.032 109.279		

REV	DATE	ALTERED	REV	DATE	ALTERED	REV	DATE	ALTERED	REV	DATE	ALTERED	REV	DATE	ALTERED
05	02.08.13	CHECKED C.Ganesh	04	31.12.12	CHECKED C.Ganesh	03	07.03.11	CHECKED C.Ganesh	02	18.02.11	CHECKED	01	20.05.09	CHECKED
ZONE	DRAWING CORRECTED BASED ON OS FEEDBACK		ZONE	ITEM-05 SH.THICK 2mm CHANGED AS 0.63mm. ITEM 01 TO 04 WT. ALTERED. TOTAL WEIGHT CORRECTED.		ZONE	Fasteners removed. Lifting hook arrangement modified based on comml feedback.		ZONE	BOM -ITEM No.05 QTY ALTERED.		ZONE	ITEM No.06&07 ADDED IN BOM. TOTAL Wt. ALTERED.	

CAUTION: The information on this document is the property of BHARAT HEAVY ELECTRICALS LTD. It must not be used directly or indirectly in any way detrimental to the interest of the company.

TYPE OF PRODUCT
OR NAME OF
CUSTOMER/PROJECT

LOAD CARRYING CAPACITY=4500Kgs.

DEPT	AQCS	GRADE OF UNTOLO.DIM	SCALE	WEIGHT (KG)	DRN	NAME	SIGN	DATE	NO.OF VAR.
862	PR: QA: 500	N.T.S	N.T.S	541.677 303.211 631.048	CHD	C.GANESH	C.GANESH	14.01.2009	-
TITLE				CARD CODE	REF. TO ASSY/OLD DRG.		ITEM NO.	NO. OF ITEMS	
TYPE-I STEEL BOX PACKING ASSEMBLY				U 01	1-SH-BAP-025		-	05	
				DRAWING NO.	REV				
				2-79-000-01740	05				

NOTES:

- 01. ALL BOX OPENING SHALL BE CLOSED USING ITEM-04 / 0.63 SHEETS.
- 02. SHEET 0.63 SHALL ALSO CAN BE FIXED USING SELF DRILL GUN AND SELF TAPPING SCREWS. TOOL REQUIRED IS SELF DRILL GUN & SCREWS ONLY.
- 03. TOP FRAME SHALL BE TACK WELD AT VENDOR WORKS TO ENABLE SHIPPING TO OPEN AND USE.
- 04. ONE COAT OF RED OXIDE PAINT IS TO BE APPLIED, TO AVOID RUSTING.
- 05. WELD 2 Δ WHEREVER NOT SHOWN.
- 06. ITEMS USED A45x45x5, ISMC75 AND SH 2.5 SHALL BE SUBSTITUED WITH MATERIALS ON HIGHER SIDE ONLY.
- 07. LOAD CARRYING CAPACITY: 2000Kgs.

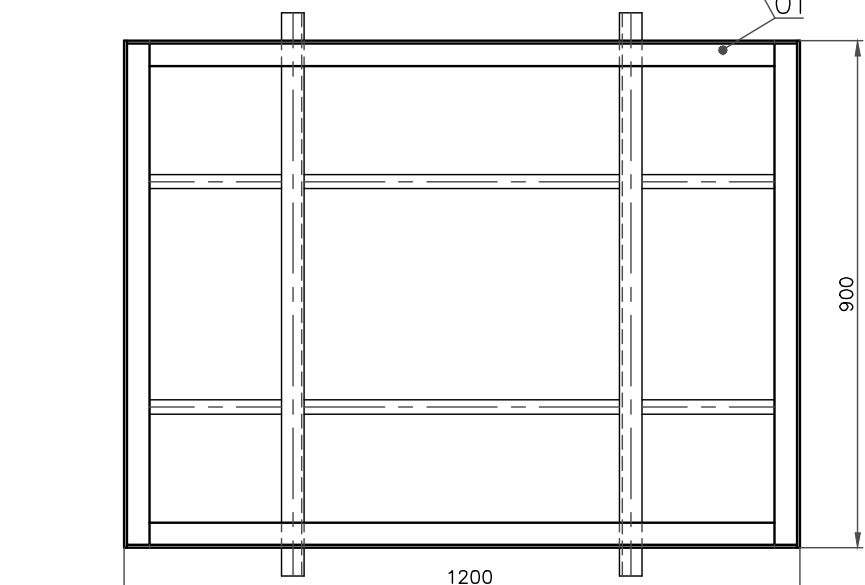
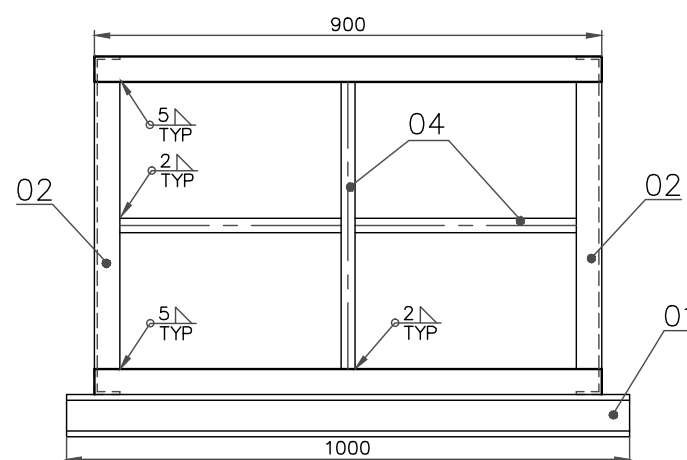
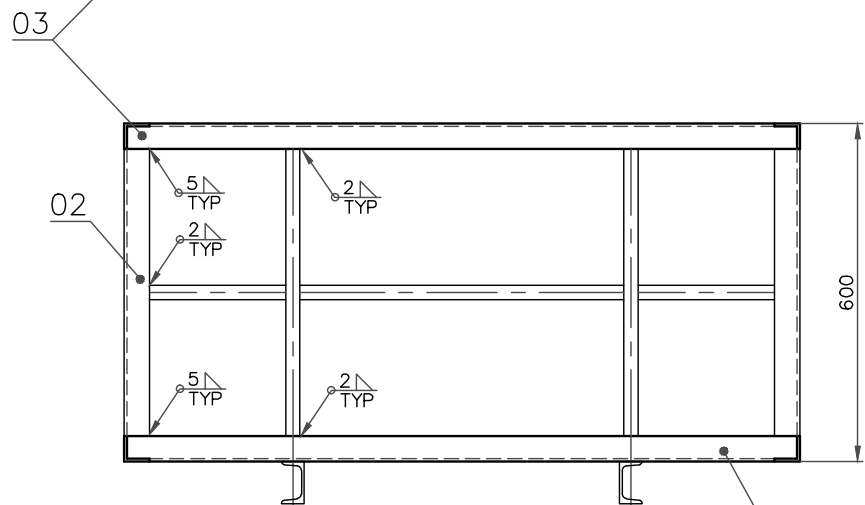
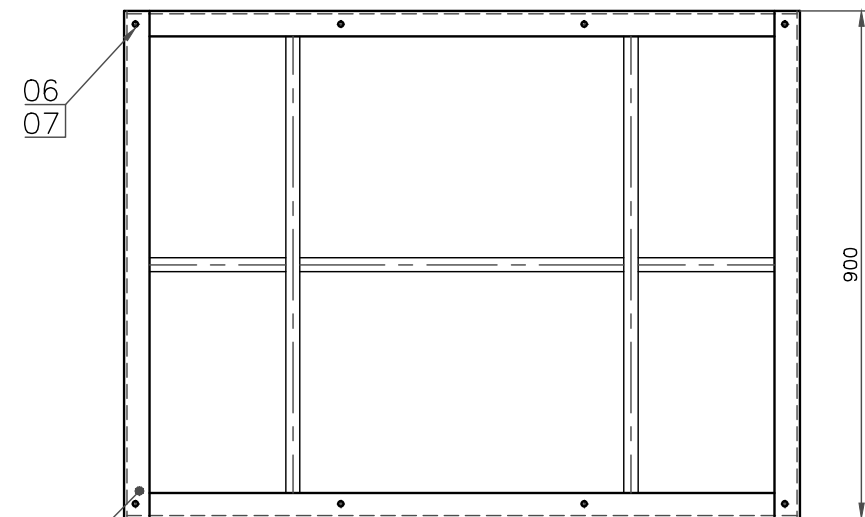

ITEM NO	DESCRIPTION	STD	DRAWING NO.	ITEM NO	MATL. CODE	A	UNIT	UNIT WT.	CS	ZONE
VAR NO	NO			VAR NO	MATL. SPEC	C	DI	QUANTITY		
07	HEX. NUT M10			413040010			NO	0.003		
				IS:1363				8		
06	SCRU.&NUT M10X25			4125510025				0.038		
				IS:1363				8		
05	SH 0.63			15-811-715		SQ		4.945		
				IS:513 DD				4.68		
04	FLAT 20X6			15-008-207		MR		0.942		
				IS:2062				2.65		
03	TOP FRAME		3-79-000-01439				NO	20.695 15.596		04
								1		
02	FRONT FRAME		3-79-000-01438				NO	5.427 4.469		05
								2		
01	BOTTOM FRAME		3-79-000-01437				NO	30.500 29.571		
								1		

REV	DATE	ALTERED	ZONE	REV	DATE	ALTERED	ZONE
04	15.02.14	CHECKED		03	05.09.12	CHECKED	
			ITEM No.03 Top Frame wt altered				ITEM No.07 DELETED IN BOM. TOTAL Wt. ALTERED.
05	22.02.14	CHECKED		02	25.03.11	CHECKED	
			Wt corrected for SI 01 & 02				ITEM No.04 DESCRIPTION & TOTAL Wt. ALTERED.
				01	20.05.09	CHECKED	
							ITEM No.06&07 ADDED IN BOM. TOTAL Wt. ALTERED.

TYPE OF PRODUCT
OR NAME OF
CUSTOMER/PROJECT

LOAD CARRYING CAPACITY 2000Kgs.

BHARAT HEAVY ELECTRICALS LTD.
UNIT: BOILER AUXILIARIES PLANT.
RANIPET - 632 406.

DRN: A.PARASU
CHD: C.GANESH
APPD: C.GANESH

DEPT: AQCS
GRADE OF UNTOLE DIM: PR: QA: 500

SCALE: N.T.S

WEIGHT (KG): 87.993
85.146

REF. TO ASSY/OLD DRG.: 3-SH-BAP-052

ITEM NO. NO. OF ITEMS: - 05

TITLE: TYPE-II STEEL BOX PACKING ASSEMBLY

CARD CODE: U 01

DRAWING NO.: 2-79-000-01714

REV: 05

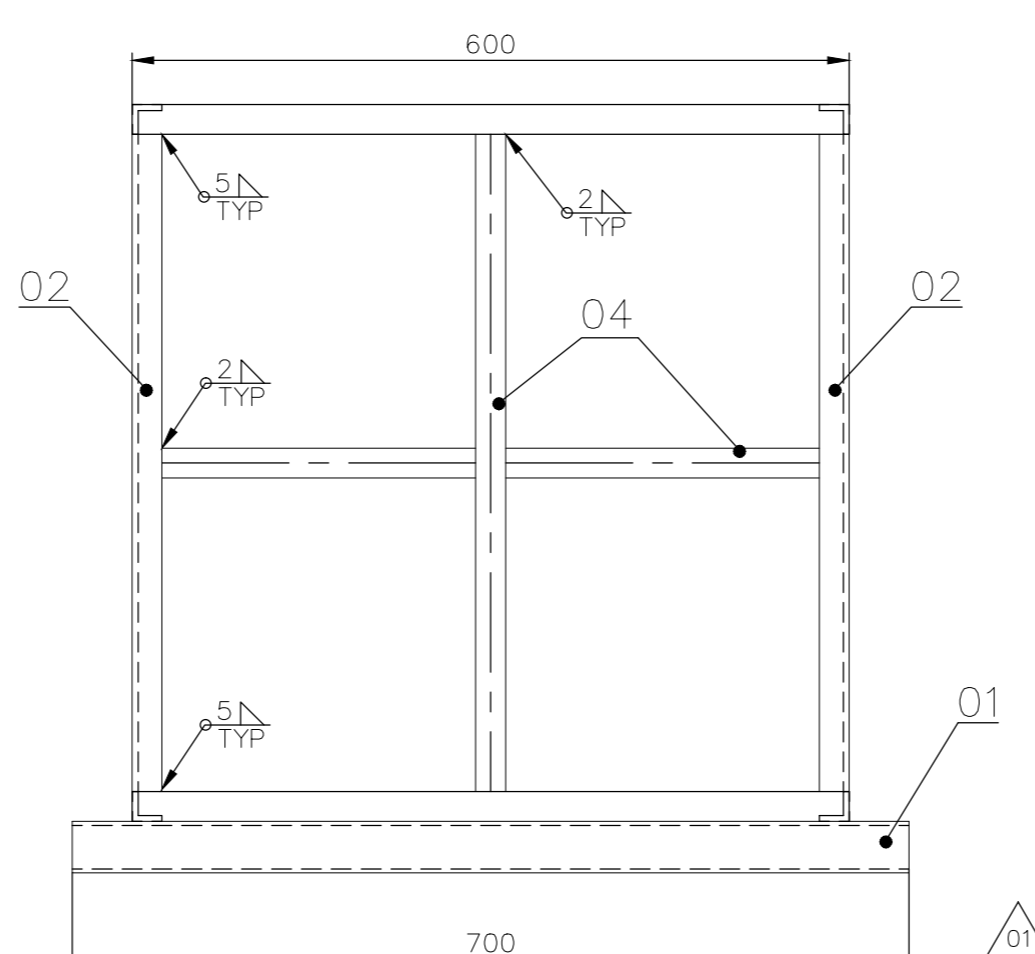
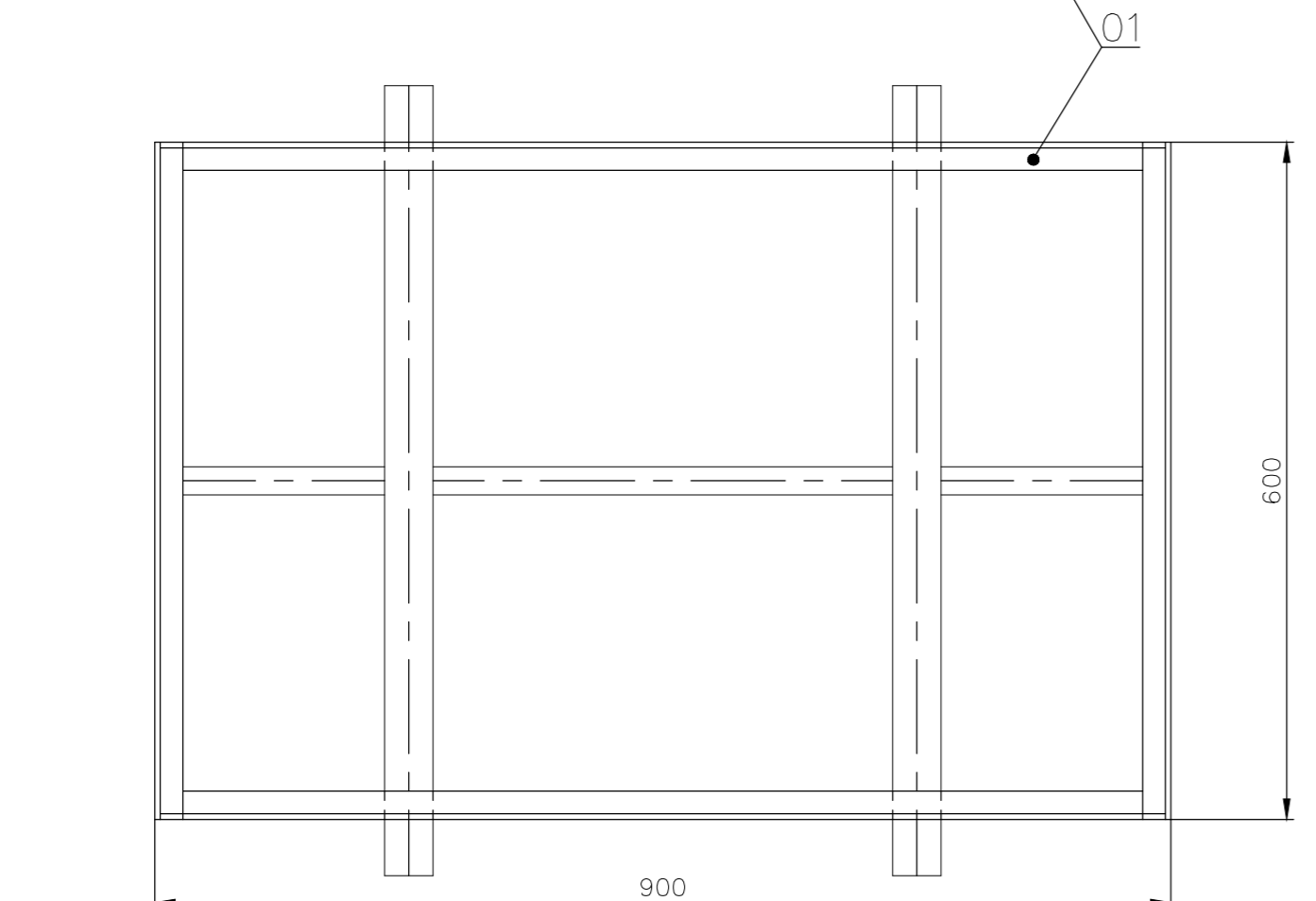
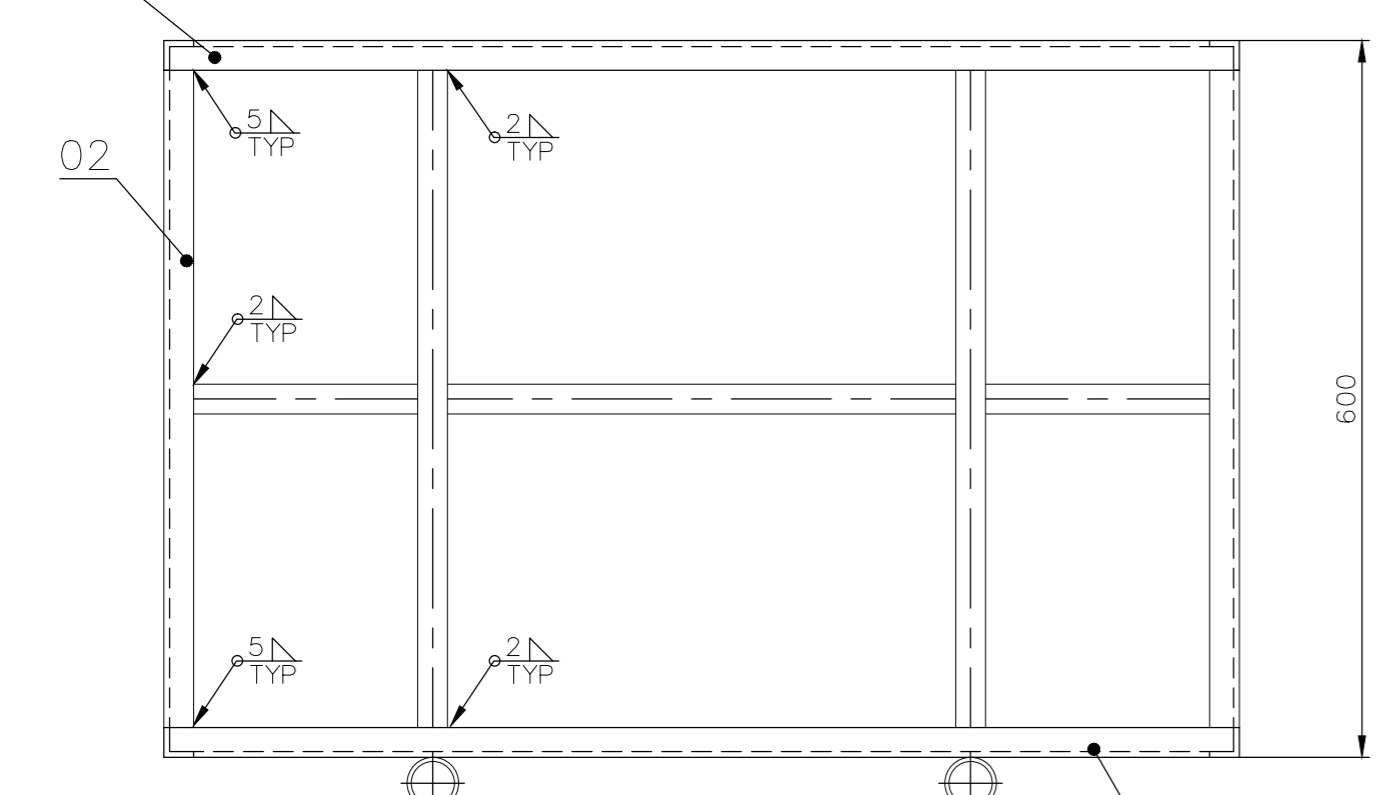
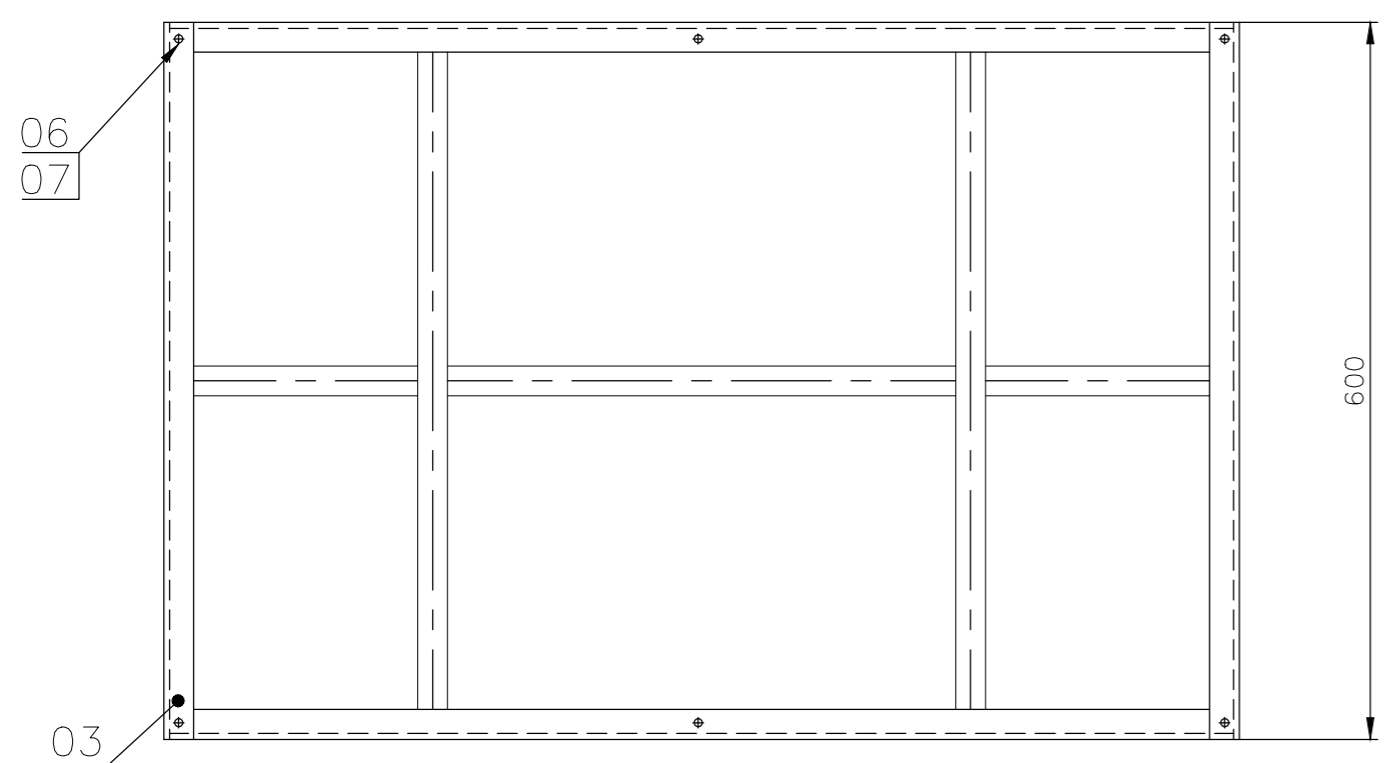

NOTES:

01. ALL BOX OPENING SHALL BE CLOSED USING ITEM-04 / 0.63 SHEETS.
02. SHEET 0.63 SHALL ALSO CAN BE FIXED USING SELF DRILL GUN AND SELF TAPPING SCREWS. TOOL REQUIRED IS SELF DRILL GUN & SCREWS ONLY.
03. TOP FRAME SHALL BE TACK WELD AT VENDOR WORKS TO ENABLE SHIPPING TO OPEN AND USE.
04. ONE COAT OF RED OXIDE PAINT IS TO BE APPLIED, TO AVOID RUSTING.
05. WELD 2 Δ WHEREVER NOT SHOWN.
06. ITEMS USED A25x25x2.5 COMMERCIAL QUALITY CAN BE USED. FOR MATERIAL SUBSTITUTION USE MATERIALS ON HIGHER SIDE ONLY.
07. ITEM USED TUBE DIA 42.9X3.25 CAN BE SUBSTITUTED ON HIGHER SIDE ONLY.
08. LOAD CARRYING CAPACITY:1000Kgs.

REV	DATE	ALTERED	BY	ZONE
06	23.06.14	CHECKED	A. Parasu	
weight corrected for item no 1&3				
05	17.12.13	CHECKED	A. Parasu	
REVISED BASED ON FEEDBACK FROM OS				
04	17.12.13	CHECKED	A. Parasu	
ITEM No.01,02&03 Wt. CORRECTED,				
03	05.09.12	CHECKED	A. Parasu	
ITEM No.07 DELETED IN BOM. TOTAL Wt. ALTERED.				
02	25.03.11	CHECKED	A. Parasu	
ITEM No.04 DESCRIPTION ALT.. TOTAL Wt. ALTERED.				
01	20.05.09	CHECKED	A. Parasu	
ITEM No.06&07 ADDED IN BOM. TOTAL Wt. ALTERED.				

ITEM NO	DESCRIPTION	STD	DRAWING NO.	ITEM NO	MATL. CODE	A	UNIT	UNIT WT.	Q	ZONE
VAR NO	NO			VAR NO	MATL. SPEC	C	DI	QUANTITY		
07	HEX. NUT M10			4130400010			NO	0.003		
				IS:1363				6		
06	SCRU.&NUT M10X25			4125510025				0.038		
				IS:1363				6		
05	SH 0.63			15-811-715			SQ	4.945		
				IS:513 DD				2.88		
04	FLAT 20X6			15-008-207			MR	0.942		
				IS:2062				2.20		
03	TOP FRAME	3-79-000-01436					NO	7.878	3.879	
								1		
02	FRONT FRAME	3-79-000-01435					NO	3.000	2.013	
								2		
01	BOTTOM FRAME	3-79-000-01434					NO	14.097	7.813	
								1		

TYPE OF PRODUCT
OR NAME OF
CUSTOMER/PROJECT

LOAD CARRYING CAPACITY 1000Kgs.

CAUTION: The information on this document is the property of BHARAT HEAVY ELECTRICALS LTD. It must not be used directly or indirectly in any way detrimental to the interest of the company.

DEPT	AQCS	GRADE OF UNTOL.DIM	SCALE	WEIGHT (KG)	REF. TO ASSY/OLD DRG.	ITEM NO.	NO.OF ITEMS
862	PR:QA:500	N.T.S	44.517	3-SH-BAP-053	-	06	

TITLE: TYPE-III STEEL BOX PACKING ASSEMBLY

CARD CODE: U 01

DRAWING NO.: 2-79-000-01713

REV: 06

NO. OF VAR.: -

DRN: A.PARASU

CHD: C.GANESH

APPD: C.GANESH

DATE: 27.12.2008

UNIT: BOILER AUXILIARIES PLANT. RANIPET - 632 406.

NOTES:

- 01. ALL BOX OPENING SHALL BE CLOSED USING ITEM-04 / 0.63 SHEETS.
- 02. SHEET 0.63 SHALL ALSO CAN BE FIXED USING SELF DRILL GUN AND SELF TAPPING SCREWS. TOOL REQUIRED IS SELF DRILL GUN & SCREWS ONLY.
- 03. TOP FRAME SHALL BE TACK WELD AT VENDOR WORKS TO ENABLE SHIPPING TO OPEN AND USE.
- 04. ONE COAT OF RED OXIDE PAINT IS TO BE APPLIED, TO AVOID RUSTING.
- 05. WELD 2 Δ WHEREVER NOT SHOWN.
- 06. ITEMS USED A45x45x5, ISMC75 AND SH 2.5 SHALL BE SUBSTITUED WITH MATERIALS ON HIGHER SIDE ONLY.
- 07. LOAD CARRYING CAPACITY: 2500Kgs.

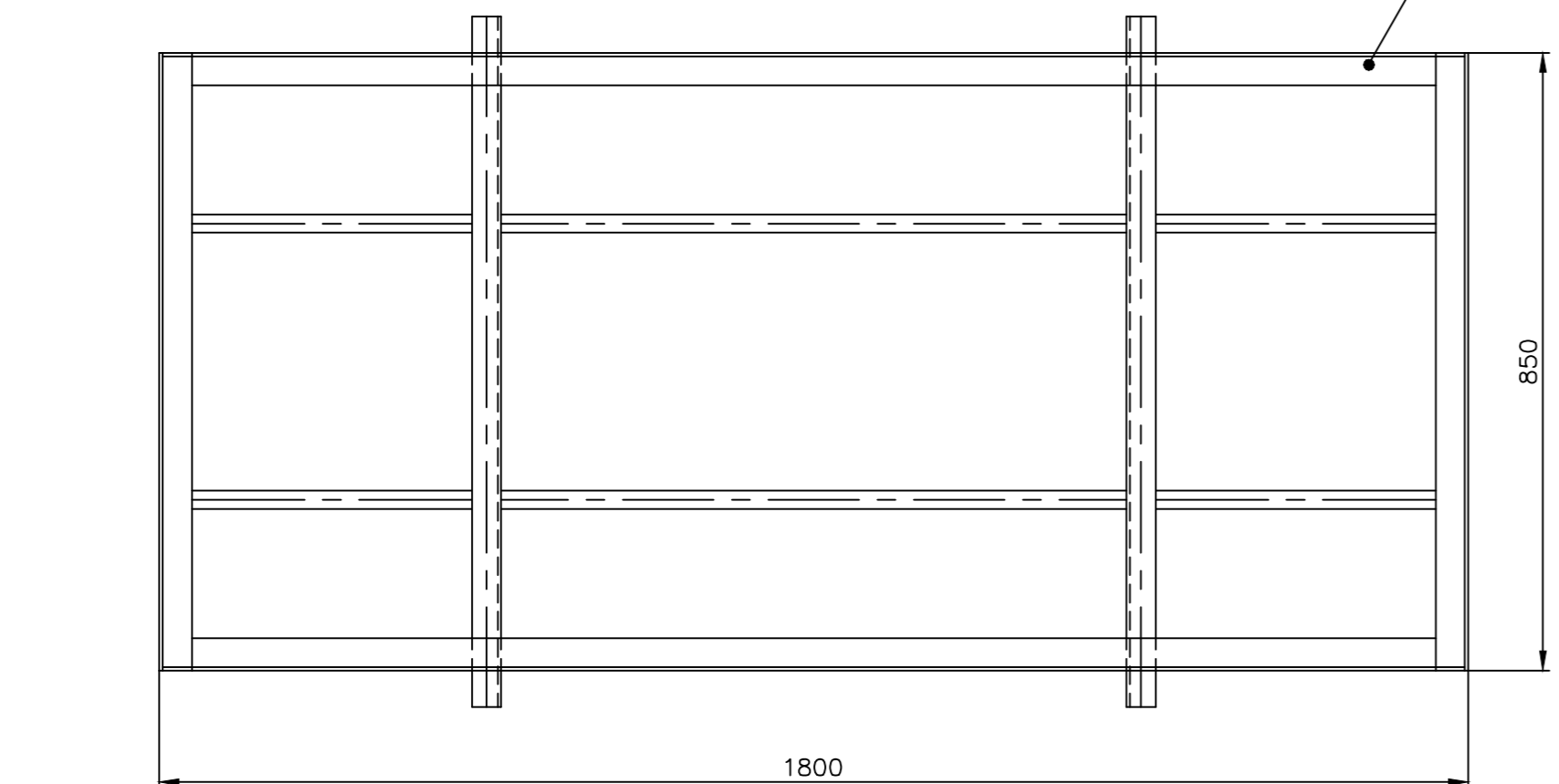
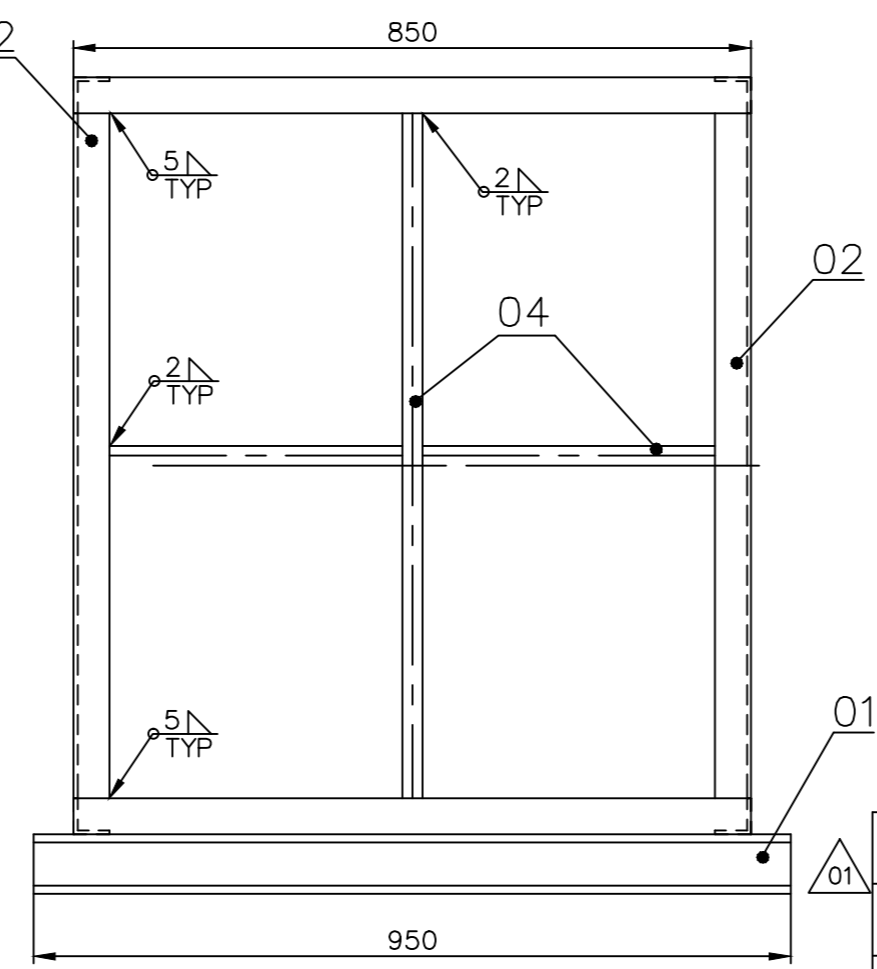
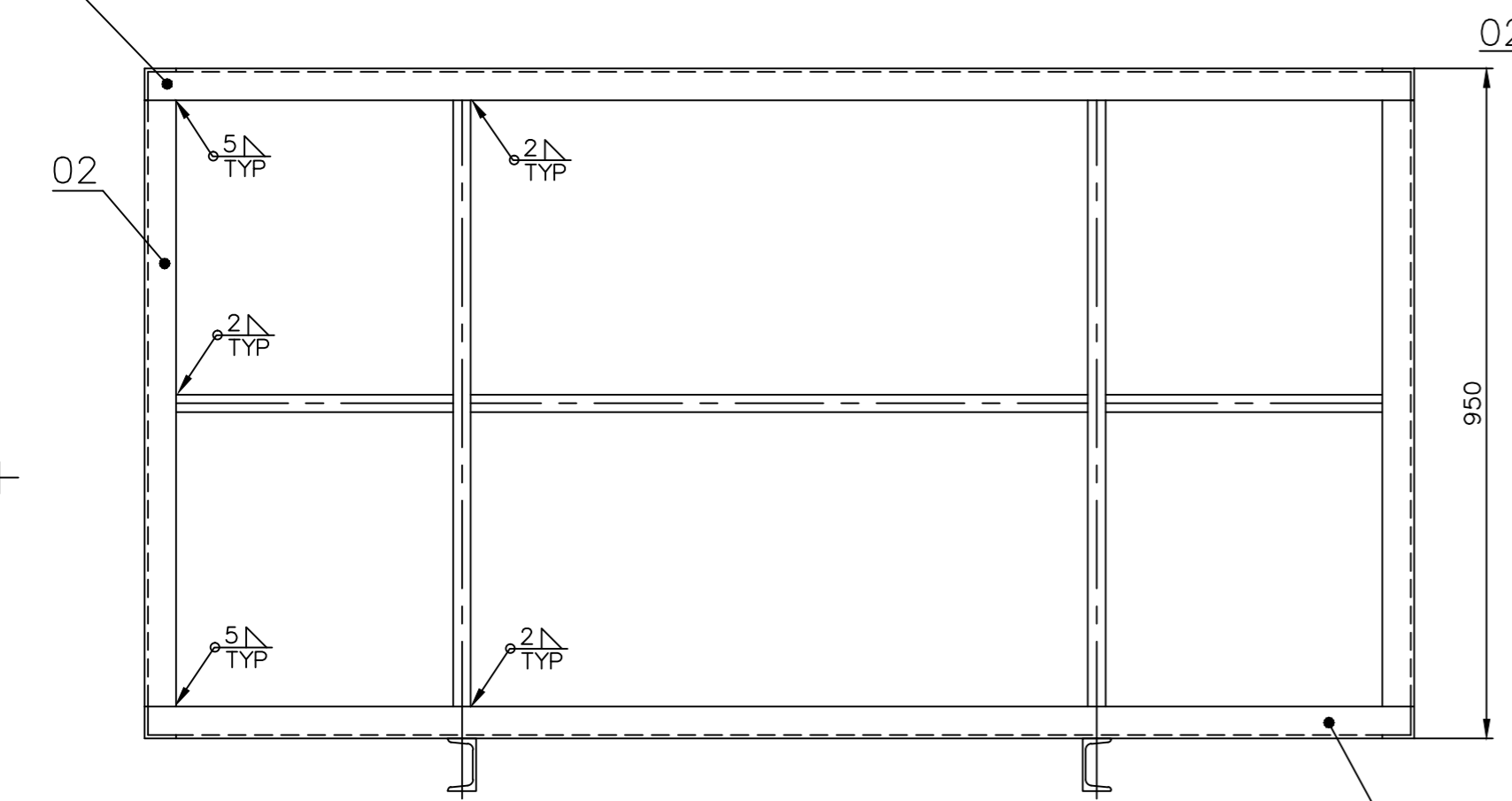
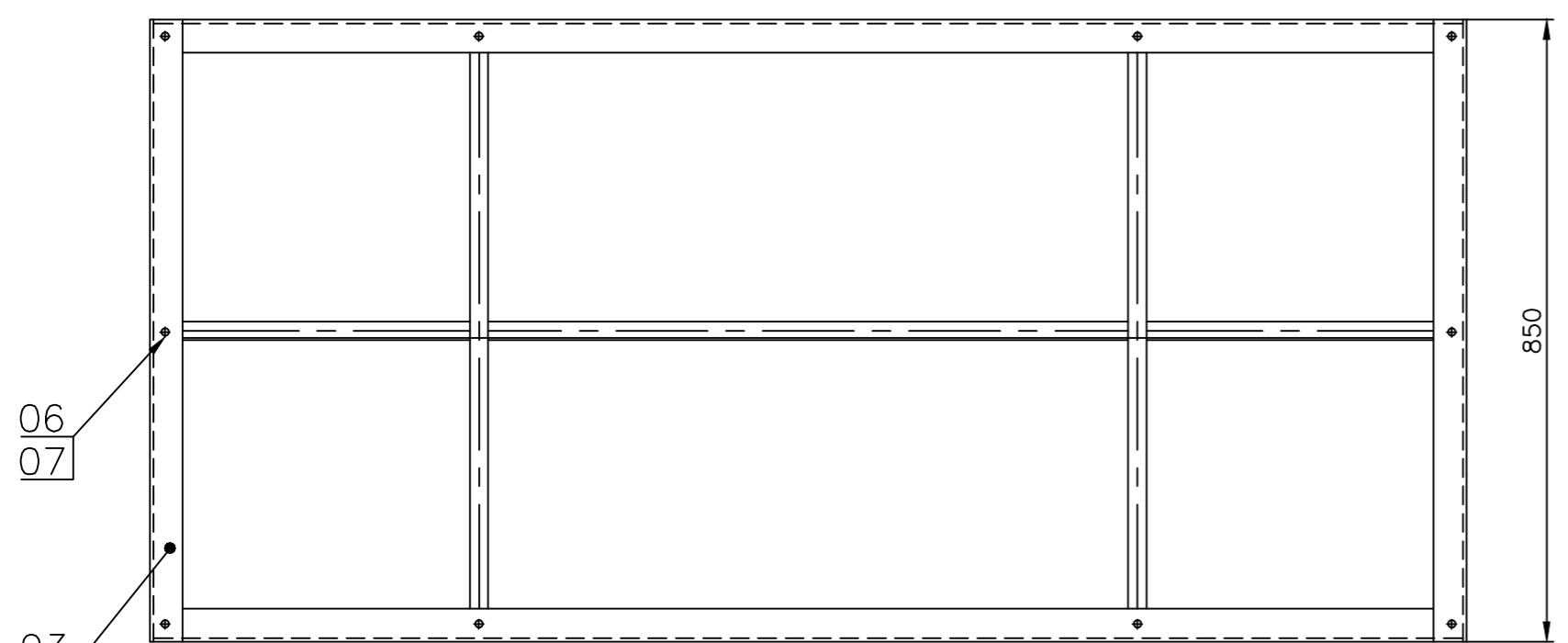

VARIANT NO	ITEM NO	DESCRIPTION	STD	DRAWING NO.	ITEM NO VAR NO	MATL. CODE	A UNIT	UNIT WT.	CS	ZONE
						MATL. SPEC	DI	QUANTITY		
	07	HEX. NUT M10				4130400010 IS:1363	NO	0.003 10		
	06	SCRU.&NUT M10X25				4125510025 IS:1363		0.038 10		
	05	SH 0.63				15-811-715 IS: 513 DD	SQ	4.945 8.095		
	04	FLAT 20X6				15-008-207 IS: 2062	MR	0.942 3.20		
	03	TOP FRAME		3-79-000-01442			NO	19.581 1		
	02	FRONT FRAME		3-79-000-01441			NO	7.507 2		
	01	BOTTOM FRAME		3-79-000-01440			NO	33.187 1		

REV	DATE	ALTERED	ZONE	REV	DATE	ALTERED	ZONE
03	05.09.12	CHECKED C.Ganesh		01	20.05.09	CHECKED	
ITEM No 07 deleted. TOTAL Wt. ALTERED.				ITEM No.06&07 ADDED IN BOM. TOTAL Wt. ALTERED.			
02	25.03.11	CHECKED C.Ganesh		01	20.05.09	CHECKED	
ITEM No. 04 DESCRIPTIO & TOTAL Wt. ALTERED.				ITEM No.06&07 ADDED IN BOM. TOTAL Wt. ALTERED.			

TYPE OF PRODUCT
OR NAME OF
CUSTOMER/PROJECT

LOAD CARRYING CAPACITY 2500Kgs.

BHARAT HEAVY ELECTRICALS LTD.,
UNIT: BOILER AUXILIARIES PLANT.
RANIPET - 632 406.

DEPT	AQCS	GRADE OF UNTOL.DIM	SCALE	WEIGHT (KG)	REF. TO ASSY/OLD DRG.	ITEM NO.	NO.OF ITEMS
862	PR: QA: 500	N.T.S	117.281	2-SH-BAP-026	-	05	

CAUTION: The information on this document is the property of BHARAT HEAVY ELECTRICALS LTD. It must not be used directly or indirectly in any way detrimental to the interest of the company.

TYPE - IIB STEEL BOX PACKING ASSEMBLY

CARD CODE: U 01

DRAWING NO. 2-79-000-01715

REV 03

DRAWING NO.

ALL DIMENSIONS ARE IN MILLIMETRES

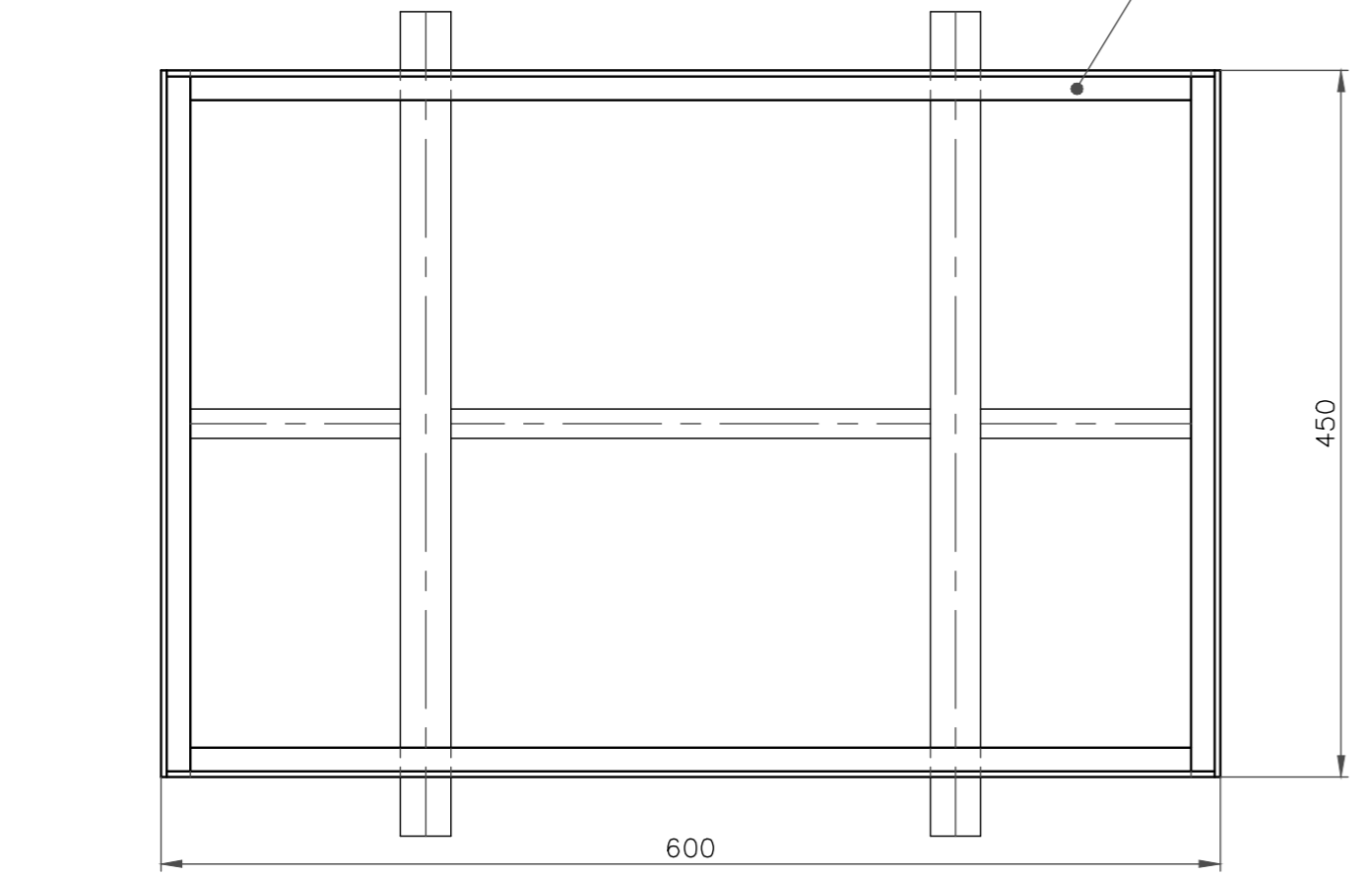
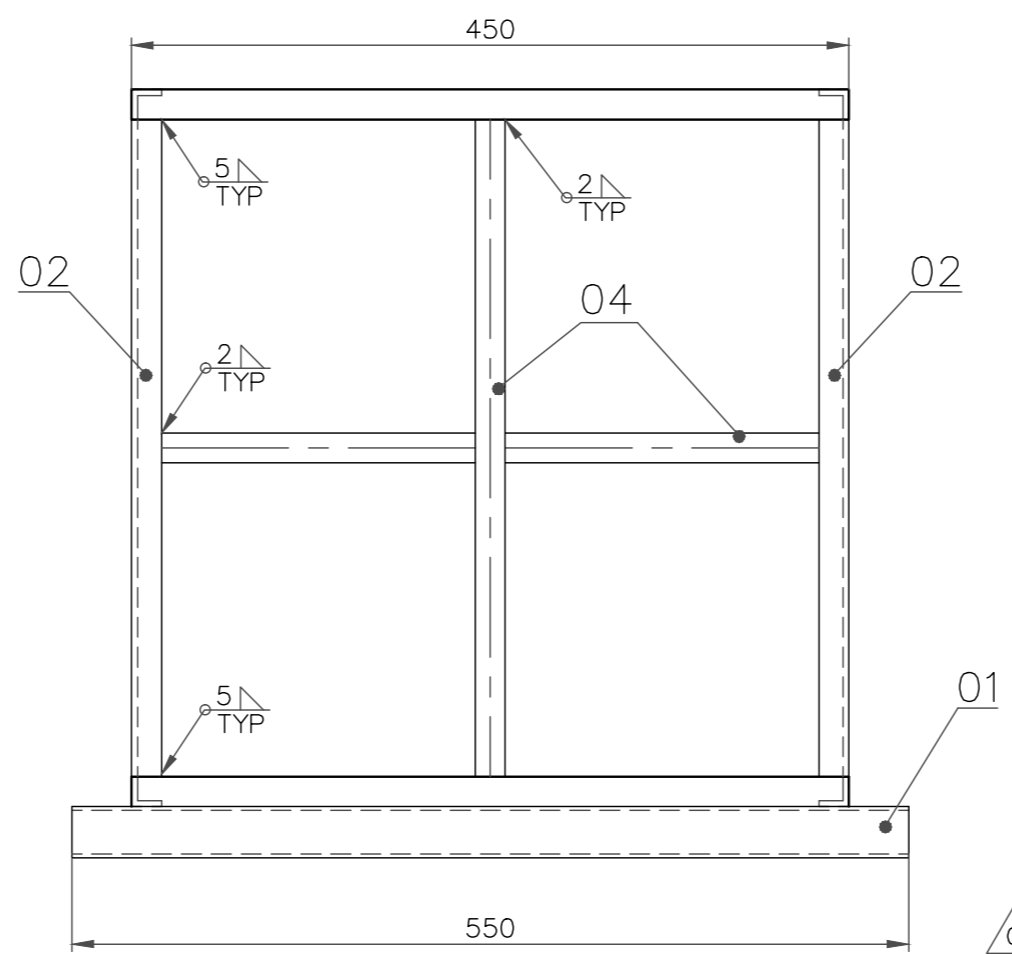
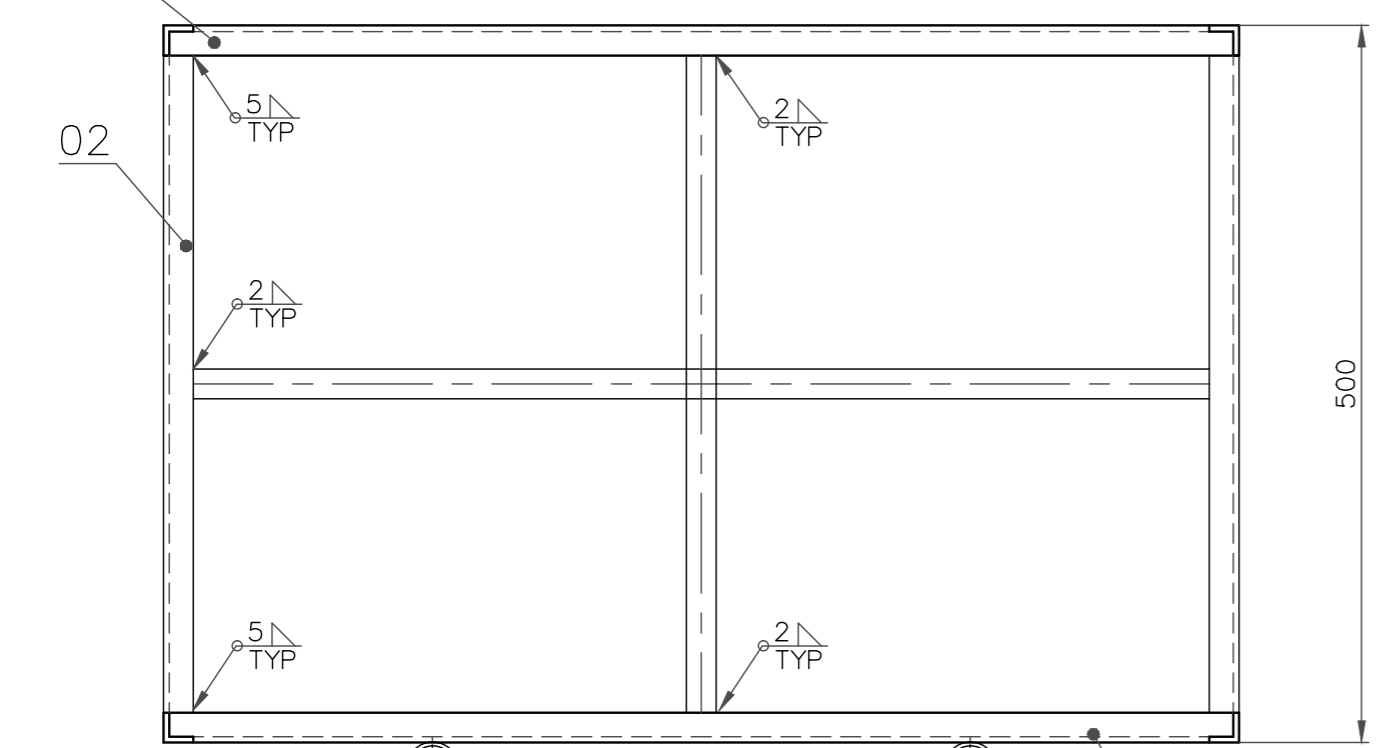
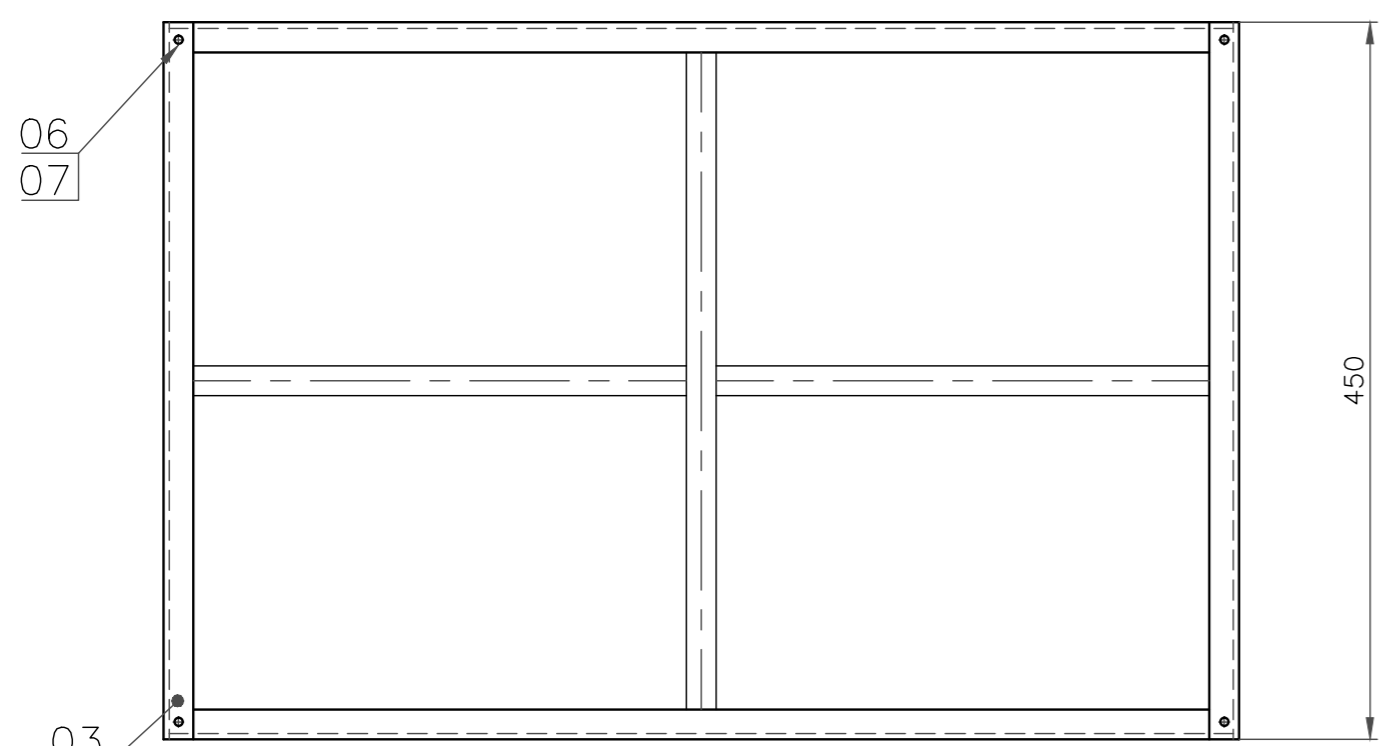

NOTES:

01. ALL BOX OPENING SHALL BE CLOSED USING ITEM-04 / 0.63 SHEETS.
02. SHEET 0.63 SHALL ALSO CAN BE FIXED USING SELF DRILL GUN AND SELF TAPPING SCREWS. TOOL REQUIRED IS SELF DRILL GUN & SCREWS ONLY.
03. TOP FRAME SHALL BE TACK WELD AT VENDOR WORKS TO ENABLE SHIPPING TO OPEN AND USE.
04. ONE COAT OF RED OXIDE PAINT IS TO BE APPLIED, TO AVOID RUSTING.
05. WELD 2 Δ WHEREVER NOT SHOWN.
06. ITEMS USED A25x25x2.5 COMMERCIAL QUALITY CAN BE USED. FOR MATERIAL SUBSTITUTION USE MATERIALS ON HIGHER SIDE ONLY.
07. ITEM USED TUBE DIA 42.9X3.25 CAN BE SUBSTITUTED ON HIGHER SIDE ONLY.
08. LOAD CARRYING CAPACITY: 500Kgs.

REV 04	DATE 17.12.13	ALTERED CHECKED	ALtered <i>A. Parasu</i>
ZONE	REVISED BASED ON FEEDBACK FROM OS		
REV 02	DATE 25.03.11	ALTERED CHECKED	ALtered <i>A. Parasu</i>
ZONE	ITEM No.04 DESCRIPTION & TOTAL Wt. ALTERED.		
REV 03	DATE 05.09.12	ALTERED CHECKED	ALtered <i>A. Parasu</i>
ZONE	ITEM No.07 DELETED IN BOM. TOTAL Wt. ALTERED.		
REV 01	DATE 20.05.09	ALTERED CHECKED	ALtered <i>A. Parasu</i>
ZONE	ITEM No.06&07 ADDED IN BOM. TOTAL Wt. ALTERED.		

VARIANT NO	ITEM NO	DESCRIPTION	STD	DRAWING NO.	ITEM NO VAR NO	MATL. CODE	A UNIT	UNIT WT.	CS	ZONE
	07	HEX. NUT-M10				4130400010 IS:1363	NO	0.003 4		
	06	SCRU.&NUT M10X25				4125510025 IS:1363		0.038 4		
	05	SH 0.63				15-811-715 IS: 513 DD	SQ	4.945 1.60		
	04	FLAT 20X6				15-008-207 IS: 2062	MR	0.942 1.65		
	03	TOP FRAME		3-79-000-01452			NO	3.186 2.519		
	02	FRONT FRAME		3-79-000-01451			NO	1.913 1.365		
	01	BOTTOM FRAME		3-79-000-01450			NO	10.635 5.729		

TYPE OF PRODUCT
OR NAME OF CUSTOMER/PROJECT: LOAD CARRYING CAPACITY 500Kgs.

CAUTION: The information on this document is the property of BHARAT HEAVY ELECTRICALS LTD. It must not be used directly or indirectly in any way detrimental to the interest of the company.

DEPT	AQCS	GRADE OF UNTOL.DIM	SCALE	WEIGHT (KG)	REF. TO ASSY/OLD DRG.	ITEM NO.	NO. OF ITEMS
862	PR: QA: 500	N.T.S	27.265	3-SH-BAP-053	-	05	

BHARAT HEAVY ELECTRICALS LTD.,
UNIT: BOILER AUXILIARIES PLANT.
RANIPET - 632 406.

DRN: A.PARASU
CHD: C.GANESH
APPD: C.GANESH

DATE: 14.01.2009

TITLE: **TYPE-IV STEEL BOX PACKING ASSEMBLY**

CARD CODE: U 01

DRAWING NO.: **2-79-000-01741**

REV: **05**

DRAWING NO.

ALL DIMENSIONS ARE IN MILLIMETRES

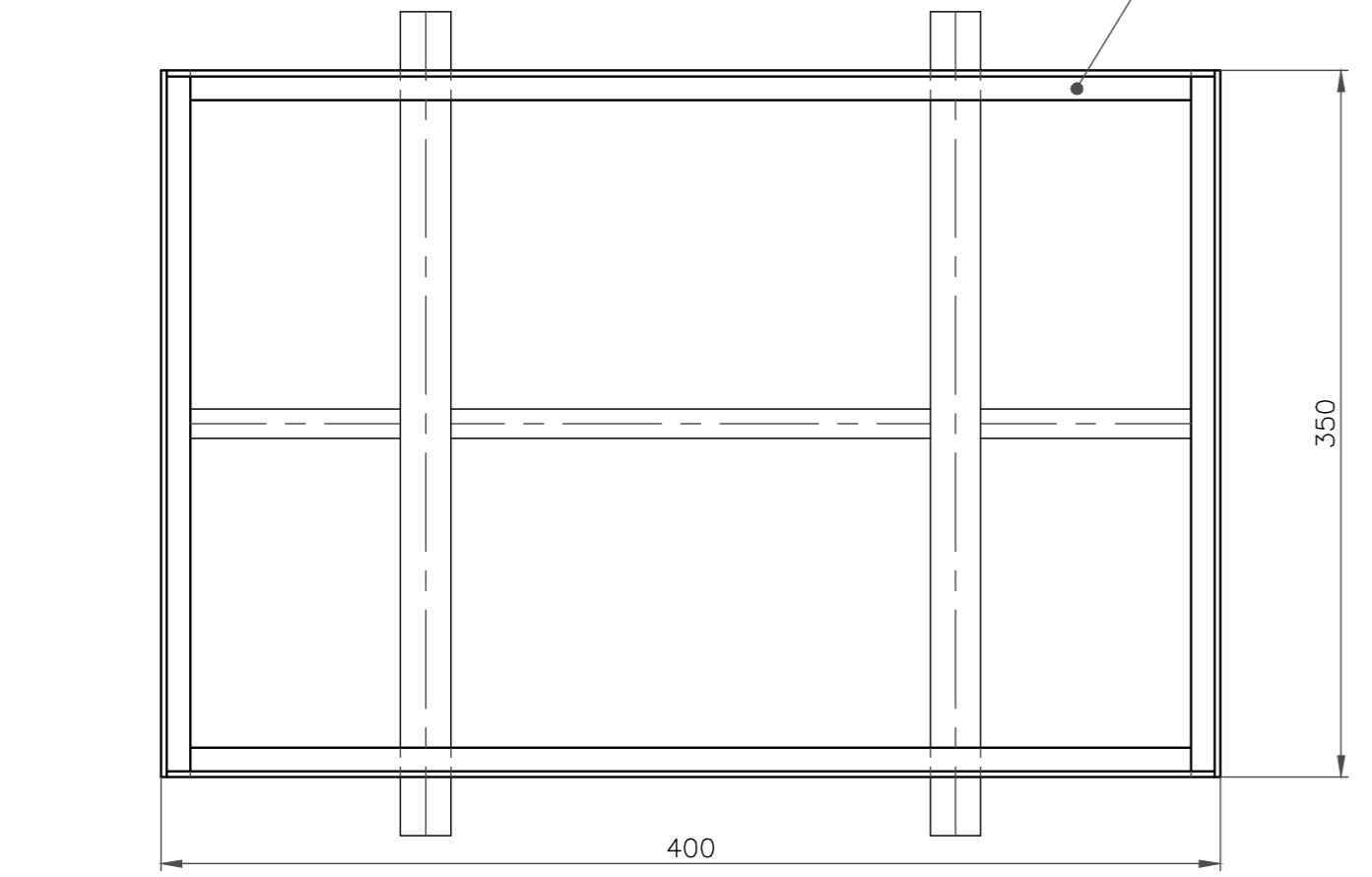
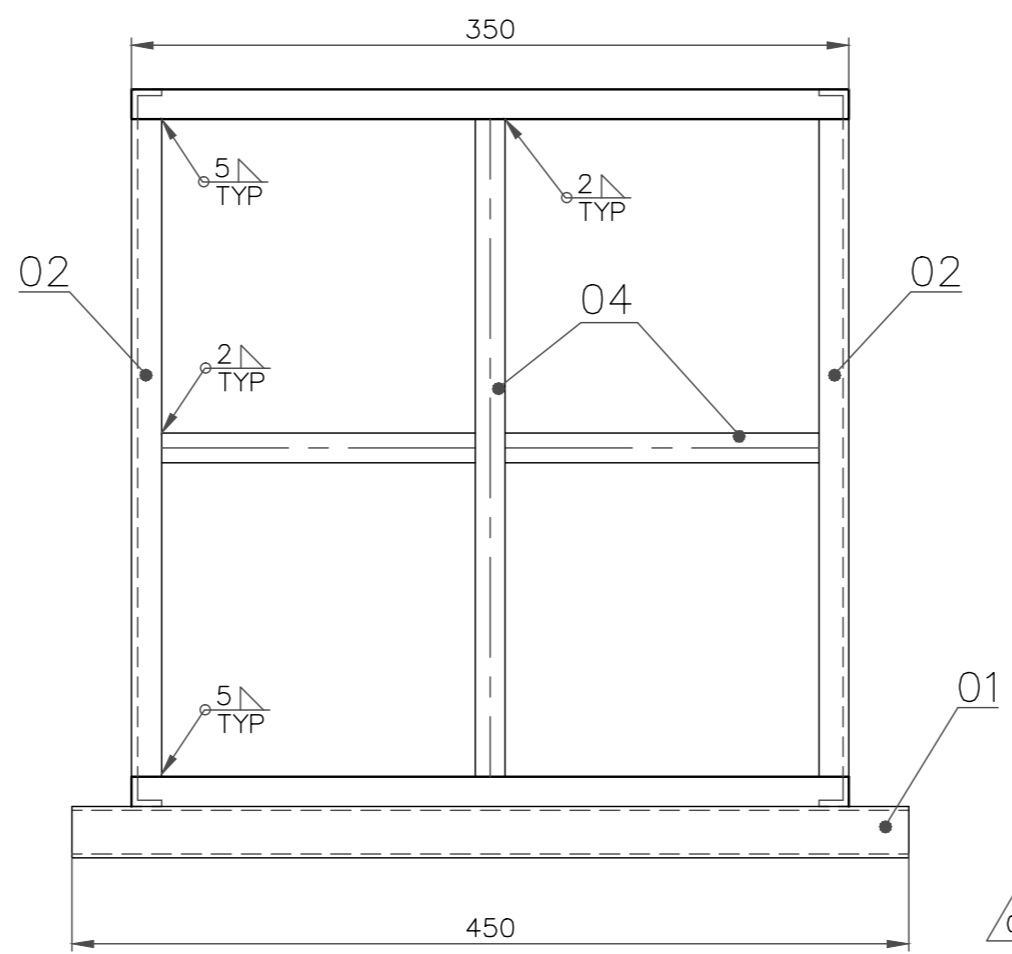
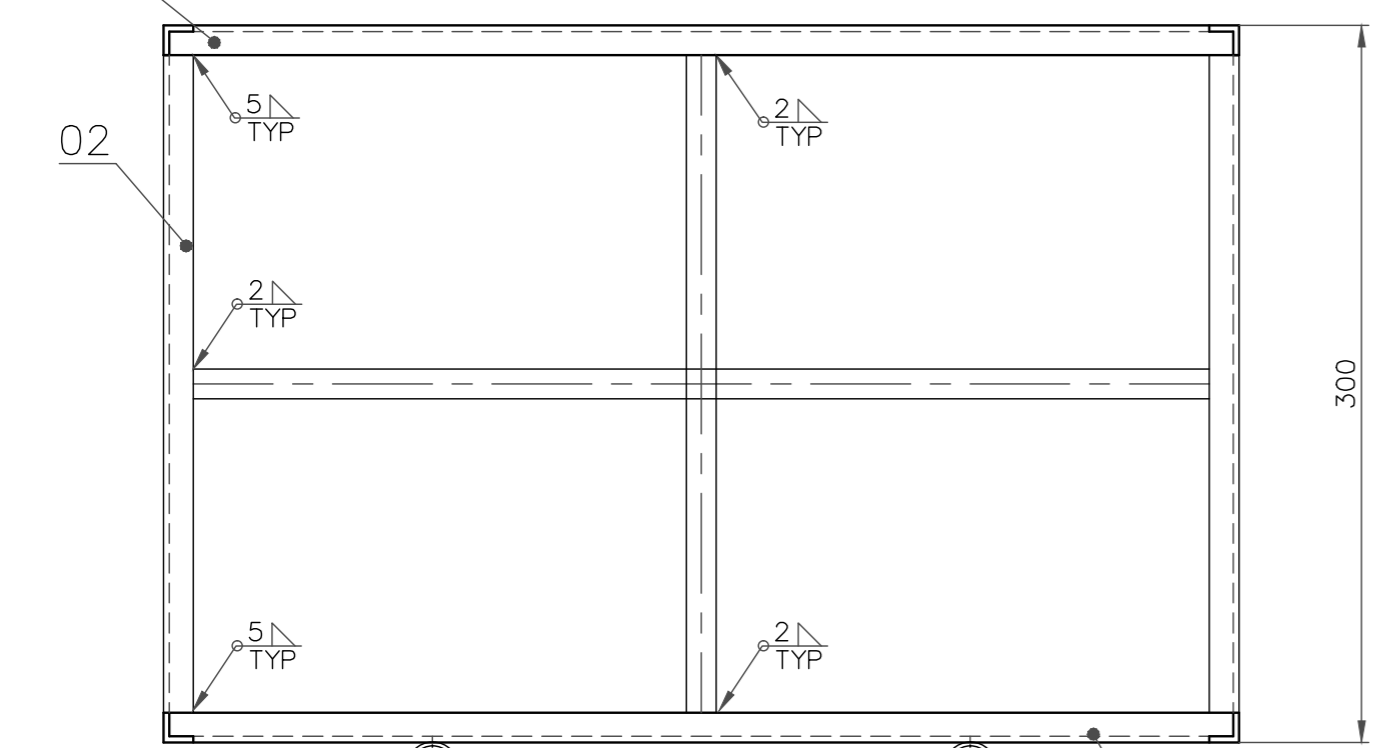
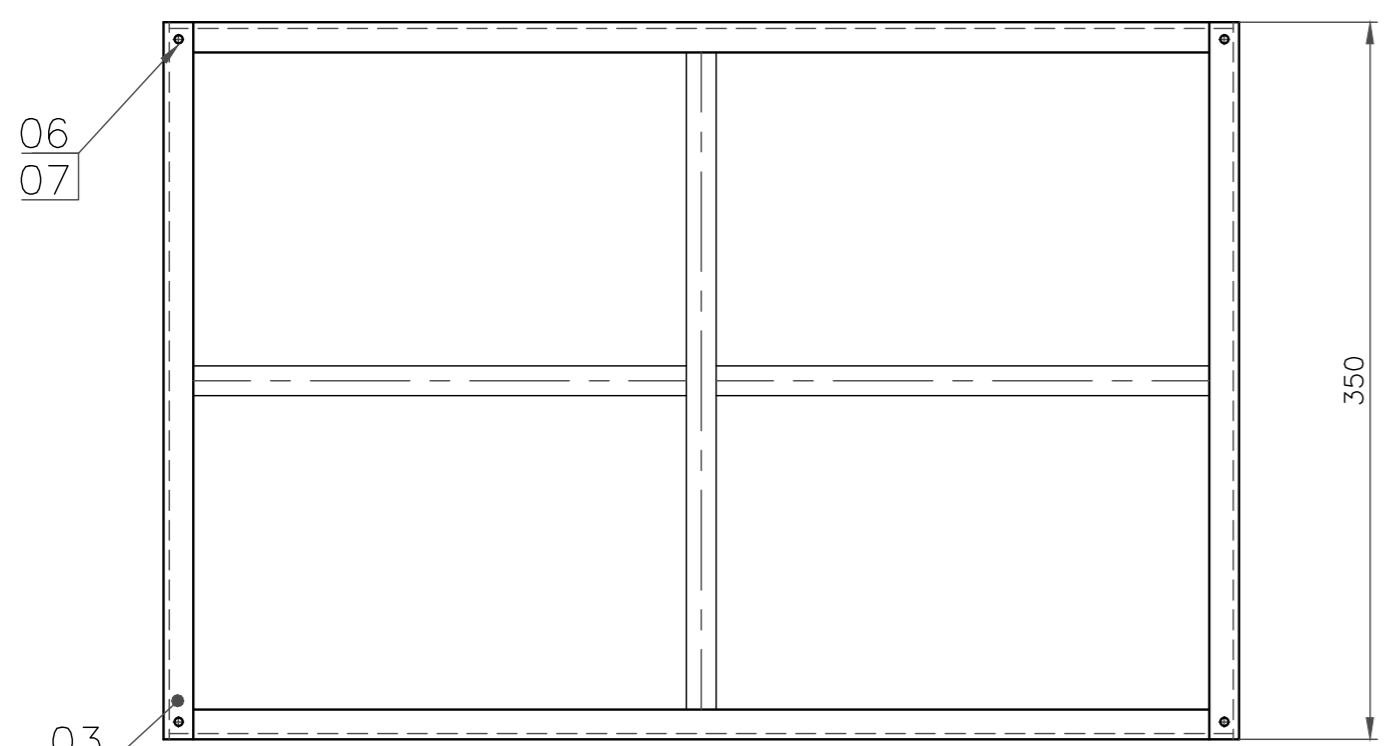

NOTES:

- 01. ALL BOX OPENING SHALL BE CLOSED USING ITEM-04 / 0.63 SHEETS.
- 02. SHEET 0.63 SHALL ALSO CAN BE FIXED USING SELF DRILL GUN AND SELF TAPPING SCREWS. TOOL REQUIRED IS SELF DRILL GUN & SCREWS ONLY.
- 03. TOP FRAME SHALL BE TACK WELD AT VENDOR WORKS TO ENABLE SHIPPING TO OPEN AND USE.
- 04. ONE COAT OF RED OXIDE PAINT IS TO BE APPLIED, TO AVOID RUSTING.
- 05. WELD 2L WHEREVER NOT SHOWN.
- 06. ITEMS USED A25x25x2.5 COMMERCIAL QUALITY CAN BE USED. FOR MATERIAL SUBSTITUTION USE MATERIALS ON HIGHER SIDE ONLY.
- 07. ITEM USED TUBE DIA 42.9X3.25 CAN BE SUBSTITUTED ON HIGHER SIDE ONLY.
- 08. LOAD CARRYING CAPACITY:200Kgs.

VARIANT NO	ITEM NO	DESCRIPTION	STD	DRAWING NO.	ITEM NO VAR NO	MATL. CODE MATL. SPEC	A C	UNIT DI	UNIT WT. QUANTITY	CS	ZONE
	07	HEX. NUT M10				4130400010 IS:1363		NO	0.003 4		
	06	SCRU.&NUT M10X25				4125510025 IS:1363			0.038 4		
	05	SH 0.63				15-811-715 IS:513 DD		SQ	4.945 0.73		
	04	FLAT 20X6				15-008-207 IS:2062		MR	0.942 1.15		
	03	TOP FRAME		3-79-000-01455				NO	3.600 1		
	02	FRONT FRAME		3-79-000-01454				NO	1.096 2		
	01	BOTTOM FRAME		3-79-000-01453				NO	8.406 1		

REV	DATE	ALTERED	BY	ZONE	REV	DATE	ALTERED	BY	ZONE
04	22.05.14	CHECKED	Nadhiya C.Ganesh		03	05.09.12	CHECKED	S. Parasu	
				ITEM No.01 to 03 WT corrected. TOTAL Wt. ALTERED.					ITEM No.07 DELETED IN BOM. TOTAL Wt. ALTERED.
02	25.03.11	CHECKED	S. Parasu		01	20.05.09	CHECKED	S. Parasu	
				ITEM No.04 DESCRIPTION & TOTAL Wt. ALTERED.					ITEM No.06&07 ADDED IN BOM. TOTAL Wt. ALTERED.

TYPE OF PRODUCT
OR NAME OF
CUSTOMER/PROJECT

LOAD CARRYING CAPACITY 200Kgs.

BHARAT HEAVY ELECTRICALS LTD.,
UNIT: BOILER AUXILIARIES PLANT.
RANIPET - 632 406.

DRN	A.PARASU	SIGN	S. Parasu	DATE	14.01.2009	NO.OF VAR.	-
CHD	C.GANESH						
APPD	C.GANESH						

DEPT	AQCS	GRADE OF UNTOL.DIM	SCALE	WEIGHT (KG).	REF. TO ASSY/OLD DRG.	ITEM NO.	NO.OF ITEMS
CODE	862	PR:QA:500	N.T.S	19,043 16.176	3-SH-BAP-030	-	05

TITLE: **TYPE-V STEEL BOX PACKING ASSEMBLY**

CARD CODE: U 01

DRAWING NO.: **2-79-000-01742**

REV: **04**

CAUTION: The information on this document is the property of BHARAT HEAVY ELECTRICALS LTD. It must not be used directly or indirectly in any way detrimental to the interest of the company.