



BHARAT HEAVY ELECTRICALS LIMITED

INDUSTRIAL VALVES PLANT, GOINDWAL SAHIB, PUNJAB

Tender Enquiry No. 1415-164 Dated 19.01.2015 due on 10.02.2015

ITEM: Fabrication Items

GENERAL TERMS AND CONDITIONS

Due Date: 10.02.2015

Pre-Qualification Term

Bidders should primarily be engaged in manufacturing and supply of Fabrication items. BHEL may carry out evaluation of bidder's capability. BHEL reserves the right to accept / reject any offer based on evaluation of bidder's capability. For verification of data presented for pre-qualification bid, BHEL may decide to visit the bidder(s) works. Any fact found deviating from bids during evaluation shall make the bidder liable to be disqualified. Vendor has to present any customer PO of Fabrication items as proof. PO date should be 01.04.2013 or afterwards.

Registered supplier with BHEL IVP Goindwal is exempted from above pre-qualification.

1. INVITING TENDERS

Tenders in two part bids are invited from for supply of 'Fabrication items' as per BHEL drawings/TDC/Specification (items in Annexures Unprice bid) on 'Annual rate contract basis'.

Sealed tenders in two parts; Part-I: Techno-commercial bid and Part-II: Price bid are hereby invited as per applicable specifications and Drawings provided by BHEL. The relevant documents are attached with the Enquiry.

The two bids should be submitted in **separate sealed inner envelopes** duly mentioning the detail as follows:

Bid	Superscribing on envelope	*** Should contain ***
Part I in First sealed envelope	Part-I (Pre-qualification) bid against tender enquiry no:1415-164 dated 19.01.2015	Pre-qualification document/Exemption proof
Part II in Second sealed envelope	Part-II (Techno-Commercial) bid against tender enquiry no:1415-164 dated 19.01.2015	a. Acceptance of all terms and conditions of tender enquiry. (Preferred is submitting signed copy of terms and conditions; if nothing is mentioned for any term, it shall be summarily concluded that the same is acceptable and no representation whatsoever shall be entertained later on). b. Un-priced bid as per format attached. All details, i.e. whether quoted for item, duties and taxes etc. should be filled.
Part III in third sealed envelope	Part-III (Price) bid against tender enquiry No: 1415-164 dated 19.01.2015	Price bid in the format attached. Preferably the price bid envelop should contain ONLY the price bid. Further, if even the same conditions are mentioned in the Part-III, but after scrutiny of Part-I and Part II, the bidder has agreed to BHEL terms, the same shall be binding and any such condition found in Part-III shall not be discussed. In case of discrepancy between prices in figures and words, prices in word will be considered as final. Anything other than prices mentioned in the price bid or prices in any other units shall be considered invalid. Rates should be quoted per unit only.

Both the sealed envelopes should be put in outer sealed envelope superscribing all details i.e. Enquiry Number, Date, Supplier's Name and Address and Item.

पिन १४



BHARAT HEAVY ELECTRICALS LIMITED

INDUSTRIAL VALVES PLANT, GOINDWAL SAHIB, PUNJAB

Tender Enquiry No. 1415-164 Dated 19.01.2015 due on 10.02.2015

ITEM: Fabrication Items

Time of submission by 1500 Hrs on Due Date. Time of Pre-qualification and Techno-Commercial bid (Part I and Part II) opening is 1530 Hrs on due date. Based on evaluation of Pre-qualification and techno-commercial offers, Price bids of bidders who qualify from Pre-qualification and techno-commercial evaluation shall be opened.

Sealed Tenders can be dropped in the tender box labeled as 'Tender box for MM contracts'. This tender box is located at the entrance of Admin block BHEL Goindwal. Fax (01859-222061) / E-Mail (tendermm@bhelivp.in) offers received in time shall be considered only when such offers are complete in all respects.

CST, VAT & Excise duty + any cess on ED at the rates applicable shall be payable extra against ED Gate Pass valid for CENVAT benefit. Rates should clearly mention basic price of the item for per box and FOR Goindwal basis. Unloading of material at Main Stores of BHEL shall be arranged by BHEL. Order of enquiry item sl. No. shall be maintained in the quotation. The rates quoted shall be firm and fixed. No price variation is proposed and allowed for full year.

Bidders, who are not currently on registered list of BHEL IVP Goindwal Sahib, may submit duly filled format for "Vendor Registration form". This duly filled form can be submitted separately/immediately without waiting for the tender opening. The form can be downloaded from our website www.bhel.com or can be requested at manmeet@bhelivp.in or amit@bhelivp.in.

BHEL reserves the right to reject offer of any bidder based on past performances/previous participation in rate contracts for supply of Fabrication Items with our unit.

Part-I: Pre-qualification

- a) Pre-qualification document or exemption proof..

Part-II: Techno-Commercial bid should contain

a) Acceptance of Techno-Commercial terms and conditions should be attached next. This can be attached either by signing each page of terms and conditions & Drawings or a confirmation statement. Any deviation proposed by bidder shall be considered by BHEL at its own discretion; and if finally considered, shall carry loading factor at the discretion of BHEL.

b) Unprice/Techno-commercial bid, filling all other details except prices. Present rate of VAT/CST & Excise duty + any cess on ED shall be mentioned in the table as %. All duties shall be paid extra. However, the comparison among bidders shall be done on the basis of quoted rates converted to "Total landed cost to BHEL". Duties shall be payable extra against ED Gate Pass valid for CENVAT benefit.

Sealed quotations shall reach by 1500 Hrs on due date. Part-I shall be opened on due date at 1530 Hrs. Based on evaluation of pre-qualification and/or techno-commercial offers, Price bids of bidders who qualify from pre-bid qualification and techno-commercial evaluation shall be opened. Date of opening of Price bid shall be informed to all successful bidders.

Part III: Price Bids should contain:

- a) Basic Price per unit in Rs for quoted items.

Price quoted shall be firm and not subject to any escalation during the PO execution.

Price should be quoted on FOR Destination Goindwal Sahib basis. If not mentioned, it shall be concluded that the offer is on FOR Destination Goindwal Sahib basis.

IF THE OFFER IS NOT ACCOMPANIED WITH ACCEPTANCE OF TERMS AND CONDITIONS, IT SHALL BE CONCLUDED THAT ALL THE TERMS AND CONDITIONS ARE ACCEPTABLE AND NO CLAIM WHATSOEVER SHALL BE ENTERTAINED LATER ON.

Handwritten signature/initials



BHARAT HEAVY ELECTRICALS LIMITED

INDUSTRIAL VALVES PLANT, GOINDWAL SAHIB, PUNJAB
Tender Enquiry No. 1415-164 Dated 19.01.2015 due on 10.02.2015
ITEM: Fabrication Items

2. VALIDITY OF OFFERS:

The offers shall be kept open for acceptance for **90 days** from the date of opening of the tender. In case of extension of tender opening date, the validity shall be suitably revised.

VALIDITY OF CONTRACT:

The rate contract will be in operation for one year **upto 31.03.2016** and may vary one month from this rate contract period. However, BHEL reserves the right to terminate the contract earlier also if the performance of the VENDOR is not satisfactory. The rate contract can be again for one more year on mutual agreement. BHEL reserves the right to short close rate contract earlier. All POs will be released in this contract period. Purchase orders will be released in this rate contract period only. **Items indicated in annexure are tentative which may increase or decrease during the contract time. Supplier has to supply material as per PO. During rate contract period BHEL may not release PO for all items indicated in annexure. Supplier may supply +/- 10% of ordered quantity with the prior approval of BHEL.**

3. SCOPE OF SUPPLY

End Covers should be supplied coated with Red Oxide Primer (IS2074). Primer paint of Red Oxide Zinc phosphate Primer (Alkyd Base) to IS 12744 has to be applied on Guard assy and Bottom Cover. The minimum thickness required after painting is 30 microns per coat.

Material shall be made of specified material as per the applicable latest Material Standard requirements/Drawing/Technical Delivery conditions attached and other requirement as given in the Purchase Order. National & International material Standards shall have to be arranged by vendors themselves. Every dispatch of material shall accompany with material code and vendor code. An advance copy of dispatch details shall be furnished to Purchase/BHEL/IVP. The materials are to be dispatched with proper packing and binding.

4. REPLACEMENT OF REJECTION:

If the material is rejected due to defective workmanship during inspection or at the time of actual use, within the guarantee period, the rejected material shall be replaced by the supplier. Corresponding quantity shall be treated as unsupplied against respective purchase order till replacement is received at BHEL. If the material is found defective and rejected during use for which payment has already been released the rejected quantity shall be supplied free of cost by the vendor within a month of intimation of the rejection by BHEL.

5. DELIVERY SCHEDULE:

Supplies shall be affected and completed as per schedule mentioned in the POs. **Time to time BHEL shall release PO on supplier for supply of fabrication items with delivery period of 45 days. If quantity of items in PO shall exceed to 2000 Nos then PO delivery date shall be 60 days.** If supplier fails to supply items within PO delivery date, BHEL reserves the right to cancel the PO and this shall be procured from other suppliers. Further, BHEL may release delivery schedule from time to time based upon our requirement. Vendor shall be required to complete the order as per the BHEL schedule requested.

6. ACCESS TO MANUFACTURING PREMISES:

While Purchase Orders placed on the vendor are under execution, authorized representatives of BHEL shall be allowed free access to the manufacturing facilities for the purpose of inspection or monitoring the progress of purchase orders. This access will also be extended to representatives of BHEL's customers accompanying the authorized representative/s of BHEL (which shall be intimated in advance), if our contractual requirements with our customers call for the same.

Handwritten signature/initials



BHARAT HEAVY ELECTRICALS LIMITED

INDUSTRIAL VALVES PLANT, GOINDWAL SAHIB, PUNJAB

Tender Enquiry No. 1415-164 Dated 19.01.2015 due on 10.02.2015

ITEM: Fabrication Items

7. TERMS OF PAYMENT:

- a. Due payment against supplies received shall be due after 30 days of receipt and acceptance of material and shall be paid within next 15 days period. In case of any deviation from standard payment term mentioned, BHEL at it's discretion may load on the item price at "Base rate of SBI (as applicable on the date of bid opening; Techno-commercial bid opening) + 6% shall be considered for loading for the period of relaxation sought by bidders.
- b. Documents to be submitted
 - i. Commercial invoice (in duplicate)
 - ii. Excise invoice (in duplicate) valid for claiming CENVAT credit
 - iii. Original VAT invoice valid for claiming input tax credit, if applicable
 - iv. Material Test Certificates (MTC) and
 - v. Compliance Certificate.
- c. Above documents should include your Registration numbers such as ECC no, PAN no, CST no, TIN/ VAT nos. etc.
- d. It is mandatory to mention proper material codes in the invoices and separate invoices to be raised for different POs.
- e. *BHEL releases payment through EFT mode ONLY. Necessary details may please be submitted by filling required format before release of payment.*

8. INSPECTION:

1. All required tests shall be carried out by vendor at no extra cost. Relevant TCs shall accompany the consignment. BHEL may decide to inspect itself/arrange third party at vendors' works itself as and when necessary with prior intimation to the vendor. No additional charges shall be claimed for such inspections.
2. Vendor will give inspection call sufficiently in advance considering the delivery period stipulated in the purchase order.
3. Material Test Certificates (MTC), Inspection reports and Compliance/Guarantee Certificate are to be provided along with the supplies.
4. Latest applicable revisions of standards/procedures to be referred.
5. Any inspection carried out before supply by vendor/incoming stage at BHEL, not withstanding, if any defect/non-conformity is noted during processing, the same shall be attended/replaced by vendor at no extra cost.

9. PREFERENCES FOR MSE's:

Preferences as mentioned in "Public Procurement Policy for Micro and Small Enterprises (MSEs) Order, 2012" shall be given to Micro and Small enterprises.

Main points which are mentioned in the above order are as follows:

- 20% Procurement of the tender value shall be made from MSE (Micro, Small Enterprises) firms.
- 4% from the above mentioned 20% procurement quantity shall be procured from MSE's owned by SC /ST's, Failure to participate by any MSE owned by SC/ST's this 4% quantity shall be procured from other MSEs.
- EMD shall be exempted for MSE's. All these benefits are subject to production of all statutory documents
- In tender, participating Micro and Small Enterprises quoting price within price band of L1+15 per cent shall also be allowed to supply a portion of requirement by bringing down their price to L1 price in a situation where L1 price is from someone other than a Micro and Small Enterprise and such Micro and Small Enterprise shall be allowed to supply up to 20 per cent of total tendered value. In case of more than one such Micro and Small Enterprise, the supply shall be shared proportionately (to tendered quantity).

11/11/15



BHARAT HEAVY ELECTRICALS LIMITED

INDUSTRIAL VALVES PLANT, GOINDWAL SAHIB, PUNJAB
Tender Enquiry No. 1415-164 Dated 19.01.2015 due on 10.02.2015
ITEM: Fabrication Items

“MSE suppliers can avail the intended benefits only if they submit along with the offer, attested copies of either EM II certificate having deemed validity (five years from the date of issue of acknowledgement in EM II) or valid NSIC certificate or EM II certificate along with attested copy of a CA certificate (Format enclosed at Annexure -1 where deemed validity of EM II certificate of five years has expired) applicable for the relevant financial year (latest audited). Date to be reckoned for determining the deemed validity will be the date of bid opening (Part 1 in case of two part bid). Non submission of such documents will lead to consideration of their bid at par with other bidders. No benefit shall be applicable for this enquiry if any deficiency in the above required documents are not submitted before price bid opening. If the tender is to be submitted through e-procurement portal, then the above required documents are to be uploaded on the portal. Documents should be notarized or attested by a Gazetted officer.”

10. LOADING

1. Tender quantity shall be divided in the proportion 60:20:20 (60% for L1, 20% for L2 and 20% for MSE's) in case the L1 vendor is not a MSE subject to following conditions:

I. L2 acceptance of L1 rates.

II. In tender, participating Micro and Small Enterprises quoting price within price band of L1+15 per cent shall also be offered 20% quantity of tender quantity at L1 price in a situation where L1 price is from someone other than a Micro and Small Enterprise. In case of more than one such Micro and Small Enterprise, the supply shall be shared equally. If there are more than one MSE in the price band of L1+ 15% to whom the offer has been sent and some of them reject the offer then the remaining quantity shall be distributed equally to the MSEs accepting L1 prices.

III. 20% from the 20% quantity (i.e. 4% of the tender quantity) offered to the MSE's shall be reserved for MSE's owned by SC/STs. In event of failure of such Micro and Small Enterprises to participate in tender process or meet tender requirements and L1 price, 4 per cent quantity for Micro and Small Enterprises owned by SC/ST entrepreneurs shall be met from other Micro and Small Enterprises.

IV. In case any MSE vendor does not accept the counter offer, the above mentioned 20% quantity shall be offered to L2.

V. If there is no MSE in the Price band of L1+15% then the 20% quantity shall be offered to L2 vendor.

VI. If other suppliers (other than L1) are not under MSE then 60% qty will be offered to L1 and 40% qty will be offered to L2 supplier.

VII. In case if the L2 vendor is MSE then quantity shall be provided as 60 % for L1, 36% for L2 and 4% tender quantity shall be offered to the MSEs owned by SC/ST's in the price band of L1+15%. In event of failure of such Micro and Small Enterprises to participate in tender process or meet tender requirements and L1 price, 4 per cent sub-target for procurement earmarked for Micro and Small Enterprises owned by SC/ST entrepreneurs shall be met from L2 vendor.

2. In case if the L1 vendor is MSE then quantity shall be provided as 60 % for L1, 36% for L2 and 4% tender quantity shall be offered to the MSEs owned by SC/ST's in the price band of L1+15%. In event of failure of such Micro and Small Enterprises to participate in tender process or meet tender requirements and L1 price, 4 per cent sub-target for procurement earmarked for Micro and Small Enterprises owned by SC/ST entrepreneurs shall be met from L2 vendor.

3. In case the L1 vendor is a MSE owned by a SC/ST then the 60% qty will be offered to L1 and 40% qty will be offered to L2 supplier.

All above offered qty are subject to acceptance of L1 rates.

In case of non- acceptance of counter offer by any vendor after above applicable provisions the whole quantity would be offered to L1 vendor.

This ratio can be altered in case of any failure on part of L1 regarding delivery commitment/quantity/quality of material.

All above mentioned preferences shall be given to MSEs and SC/STs only on the submission of documentary evidence.

14/1/15



BHARAT HEAVY ELECTRICALS LIMITED

INDUSTRIAL VALVES PLANT, GOINDWAL SAHIB, PUNJAB

Tender Enquiry No. 1415-164 Dated 19.01.2015 due on 10.02.2015

ITEM: Fabrication Items

On all new vendors not registered with our unit, initially a development PO will be released of value less than Rs 1.00 Lac with a delivery period of 60 days. On successful completion of this development order only, further order will be released.

11. PENALTY FOR LATE DELIVERY:

'Time is the essence of the contract'. As such, delivery of goods specified in the Purchase Orders released under the scope of this contract shall be made within the time limit prescribed therein. Penalty for late delivery will be applicable @ 0.5% per week or part thereof subject to a maximum of 10.0%.

If any vendor does not accept LD ½% of the supply for each week of delay subject to a maximum of 5%, their offer is likely to be rejected by BHEL and the price bid shall not be opened. Bidders accepting for 10% LD shall not be loaded on account of LD. However bidders who offer any other % LD [between 5% to 10%] shall be loaded @ % deviation from 10% and their accepted % e.g. If a bidder accepts for a max of 7% LD only, their offer would be loaded @ 3% (10 - 7 = 3).

BHEL reserves the right to receive or not receive the material after the due date of PO.

12. GUARANTEE:

Vendor shall give a guarantee of 18 months from the date of dispatch or 12 months from date of receipt, against manufacturing defects, whichever is earlier. In case of non-acceptance of this term bid will be rejected.

13. RISK PURCHASE:

BHEL shall be entitled to terminate the contract with any vendor and to purchase elsewhere at the risk and cost of the vendor, either the whole or part thereof which the supplier has failed to deliver within the time stipulated as aforesaid. Vendor shall be liable for the losses, which BHEL may sustain by way of such risk purchase in addition to aforesaid penalty for delayed delivery. Purchases made from any other vendor at its quoted rates shall be made and the difference of rates of defaulter vendor and new vendor shall be deducted from running bills of the vendor who has failed to deliver.

14. SUB-CONTRACT:

The purchase order or any part thereof shall not be sub-contracted, assigned or otherwise transferred without previously obtaining the BHEL's consent in writing.

15. FORCE MAJEURE:

If at any time during the continuance of the contract, the performance in which or in any part by either party of any obligations under the contract are prevented or delayed by reason of any war, hostilities, acts of public enemy, civil commotion, sabotage, fires, explosions, epidemics, quarantine restrictions, or acts of God (hereinafter referred to "an events" then provided the notice of happening of any such event is given by either party to the other within 21 days of the occurrence thereof, neither party shall by reason of such event be entitled to terminate the contract nor shall either party have any claim for damages against the other in respect of such non-performance and delay in performance and delivery under the contract shall be resumed as soon as practicable after such event has come to an end or ceased to exist. If the performance in whole or part of any obligation under the contract is prevented or delayed by reason of any such event, claims of extension of time shall be granted for periods considered reasonable by BHEL subject to prior notification by the vendor to BHEL of the particulars of the event and supply to BHEL, if required, of any supporting evidence. Any waiver of time in respect of partial installment shall not be deemed a waiver of time in respect of remaining deliveries.

16. DISPUTES:

4/11/15



BHARAT HEAVY ELECTRICALS LIMITED

INDUSTRIAL VALVES PLANT, GOINDWAL SAHIB, PUNJAB
Tender Enquiry No. 1415-164 Dated 19.01.2015 due on 10.02.2015
ITEM: Fabrication Items

In the event of any dispute and/or difference arising between the Vendor and BHEL as to interpretation and/or execution of the contract and/or the respective rights and liabilities of the parties, such disputes and/or differences shall be referred to the sole arbitrator nominated by BHEL. The provisions of the Indian Arbitration Act and the rules there under shall apply to such arbitration. The award passed by the arbitrator shall be final and conclusively binding on all the parties.

17. JURISDICTION:

The court of the place from where the purchase order is issued during the contractual period shall alone have jurisdiction to decide any dispute arising out of or in connection with the purchase order.

18. MSME & MSE Certification:

If the bidder is registered as any of Micro/Small/Medium enterprise as defined in Micro Small and Medium Enterprises Development Act, 2006; a copy of registration certificate to be attached. MSE's shall be given preferences as described in "Public Procurement Policy for Micro and Small Enterprises (MSEs) Order, 2012" subject to the submission of proper documentary evidence (i.e. District Industries Centers or Khadi and Village Industries Commission or Khadi and Village Industries Board or Coir Board or National Small Industries Corporation or Directorate of Handicrafts and Handloom or any other body specified by Ministry of Micro, Small and Medium Enterprises) with quotation. "Public Procurement Policy for Micro and Small Enterprises (MSEs) Order, 2012" document can be downloaded from link <http://dmsme.gov.in/FinalPressorder.pdf> and can also be collected from the office of DGM/MM IVP Goindwal.

19. CLARIFICATIONS

The correspondence exchanged against the tender from both tenderer and BHEL through email are considered as valid document legally though it is not signed. It is treated as valid confirmations made on behalf of the respective company and very much comes under the legal ambit of the business transaction and hence it is binding on both the parties to the business. Any transaction pertaining to the tender from both the parties of business done round the clock irrespective of the office or business hours of the companies, are valid legally and binding on both the parties. This applies to the extent only in such cases where deadline time for transaction is not specifically declared by either or both the parties to the business.

20. LOI (Letter of Intent)

BHEL may issue LOI prior to the PO for any reason whatsoever. The LOI in such cases is to be treated as PO for all practical purposes and all the Terms & Conditions of the tender shall be applicable from the date of issue of LOI.

21. GENERAL:

- a) BHEL will not be bound by any power of attorney granted by the vendors or by changes in the composition of the firm made subsequent to the execution of the contract. They may, however, recognize such power of attorney and changes after obtaining proper legal advice, the cost of which will be chargeable to the vendor concerned.
- b) BHEL reserves the right to extend the due date of opening, which shall be informed. Validity of offer shall be deemed to be revised accordingly.
- c) BHEL reserves the right to accept or reject any part or whole of the tender of a bidder by assigning a valid reason thereof. BHEL reserves the right to cancel the tender without assigning any reason thereof and without any obligation before any commitment.

11/1/15



BHARAT HEAVY ELECTRICALS LIMITED

INDUSTRIAL VALVES PLANT, GOINDWAL SAHIB, PUNJAB

Tender Enquiry No. 1415-164 Dated 19.01.2015 due on 10.02.2015

ITEM: Fabrication Items

- d) If possible, please submit soft copy of price quotation [copied on a blank CD of standard make] put in the sealed offer.
- e) Acceptance of all terms and conditions, in the form of signed copy of T&C or confirmation separately written, shall be submitted along with quotation. If nothing is mentioned; it shall be concluded that terms and conditions are acceptable.
- f) Advance tax is applicable as on date on these items at Punjab border. Supplier has to deposit this advance tax by himself which will be reimbursed on submission of documentary proofs (Copy of entry tax receipt/online transfer details duly verified).

22. BANNED FIRMS:

The offers of the bidders who are on the banned list as also the offer of the bidders, who engage the services of the banned firms, shall be rejected. The list of banned firms is available on BHEL website www.bhel.com.

23. REVERSE AUCTION

"BHEL reserves the right to go for Reverse Auction (RA) instead of opening the sealed envelope price bid, submitted by the bidder. This will be decided after techno-commercial evaluation. All bidders to give their acceptance for participation in RA. Non-acceptance to participate in RA may result in non-consideration of their bids, in case BHEL decides to go for RA.

In case BHEL decides to go for Reverse Auction, only those bidders who have given their acceptance to participate in RA will be allowed to participate in the Reverse Auction. Those bidders who have given their acceptance to participate in Reverse Auction will have to necessarily submit "online sealed bid" in the Reverse Auction. Non-submission of „online sealed bid" by the bidder will be considered as tampering of the tender process and will invite action by BHEL as per extant guidelines in vogue."

Terms & Conditions of Reverse Auction

Against this enquiry for the subject item/ system with detailed scope of supply as per enquiry specifications, BHEL may resort to "REVERSE AUCTION PROCEDURE" i.e., ON LINE BIDDING (THROUGH A SERVICE PROVIDER). The philosophy followed for reverse auction shall be English Reverse (No ties).

1. For the proposed reverse auction, technically and commercially acceptable bidders only shall be eligible to participate.
2. Those bidders who have given their acceptance for Reverse Auction (quoted against this tender enquiry) will have to necessarily submit "online sealed bid" in the Reverse Auction. Non-submission of „online sealed bid" by the bidder for any of the eligible items for which techno-commercially qualified, will be considered as tampering of the tender process and will invite action by BHEL as per extant guidelines in vogue.
3. BHEL will engage the services of a service provider who will provide all necessary training and assistance before commencement of on line bidding on internet.
4. In case of reverse auction, BHEL will inform the bidders the details of Service Provider to enable them to contact & get trained.
5. Business rules like event date, time, bid decrement, extension etc. also will be communicated through service provider for compliance.
6. Bidders have to fax the Compliance form (annexure IV) before start of Reverse auction. Without this, the bidder will not be eligible to participate in the event.
7. In line with the NIT terms, BHEL will provide the calculation sheet (e.g., EXCEL sheet) which will help to arrive at "Total Cost to BHEL" like Packing & forwarding charges, Taxes and Duties, Freight charges, Insurance, Service Tax for Services and loading factors (for non-compliance to BHEL standard Commercial terms & conditions) for each of the bidder to enable them to fill-in the price and keep it ready for keying in during the Auction.
8. Reverse auction will be conducted on scheduled date & time.

Handwritten signature



BHARAT HEAVY ELECTRICALS LIMITED
INDUSTRIAL VALVES PLANT, GOINDWAL SAHIB, PUNJAB
Tender Enquiry No. 1415-164 Dated 19.01.2015 due on 10.02.2015
ITEM: Fabrication Items

9. At the end of Reverse Auction event, the lowest bidder value will be known on auction portal.
10. The lowest bidder has to fax/e-mail the duly signed and filled-in prescribed format for price breakup including that of line items, if required, (Annexure VII) as provided on case-to-case basis to Service provider within two working days of Auction without fail.
11. In case BHEL decides not to go for Reverse Auction procedure for this tender enquiry, the Price bids and price impacts, if any, already submitted and available with BHEL shall be opened as per BHEL's standard practice.
12. Bidders shall be required to read the "Terms and Conditions" section of the auctions site of Service provider, using the Login IDs and passwords given to them by the service provider before reverse auction event. Bidders should acquaint themselves of the "Business Rules of Reverse Auction", which will be communicated before the Reverse Auction.
13. If the Bidder or any of his representatives are found to be involved in Price manipulation/ cartel formation of any kind, directly or indirectly by communicating with other bidders, action *as per extant BHEL guidelines*, shall be initiated by BHEL and the results of the RA scrapped/ aborted.
14. The Bidder shall not divulge either his Bids or any other exclusive details of BHEL to any other party.
15. In case BHEL decides to go for reverse auction, the H1 bidder (whose quote is highest in online sealed bid) may not be allowed to participate in further RA process.

24. WORDS AND FIGURES

- a. If, in the price structure quoted for the required goods/ services/ works, there is discrepancy between the unit price and the total price (which is obtained by multiplying the unit price by the quantity), the unit price shall prevail and the total price corrected accordingly, unless in the opinion of the purchaser there is an obvious misplacement of the decimal point in the unit price, in which case the total price as quoted shall govern and the unit price corrected accordingly.
- b. If there is an error in a total corresponding to the addition or subtraction of subtotals, the subtotals shall prevail and the total shall be corrected; and
- c. If there is a discrepancy between words and figures, the amount in words shall prevail, unless the amount expressed in words is related to an arithmetic error, in which case the amount in figures shall prevail subject of (a) and (b) above.
- d. If there is such discrepancy in an offer, the same shall be conveyed to the bidder with target date upto which the bidder has to send his acceptance on the above lines and if the bidder does not agree to the decision of the purchaser, the bid is liable to be ignore

CHECKLIST AND SEQUENCE OF DOCUMENTS TO BE SUBMITTED IN TWO PARTS BIDS

S. No.	Document	Status [pl. check the following for ready ref]
1.	Pre-qualification Bid sealed in separate Second envelope superscribing tender enquiry detail, due date of opening, sender address	Sealed envelope marked as Part-I "Pre-qualification Bid" Yes Envelop sealed
2.	Techo-commercial/Unprice Bid sealed in separate Second envelope superscribing tender enquiry detail, due date of opening, sender address	Sealed envelope marked as Part-II "Techo-commercial Bid" Yes Envelop sealed
3.	Price Bid sealed in separate Second envelope superscribing tender enquiry detail, due date of opening, sender address	Sealed envelope marked as Part-III "Price Bid" Yes Envelop sealed
4.	All three sealed envelopes put in an outer envelope mentioning all details like Enquiry no., description, due date	Yes

Certificate by Chartered Accountant on letter head

This is to Cert'fy that M/S,
(hereinafter referred to as 'company') having its registered office at
..... is registered under MSMED Act 2006, (Entrepreneur
Memorandum No (Part-11) dtd:.....,
Category:..... (Micro/Small)). (Copy enclosed).

Further verified from the Books of Accounts that the investment of the company as per the
latest audited financial year as per MSMED Act 2006 is as follows:

1. **For Manufacturing Enterprises:** Investment in plant and machinery (i.e. original cost
excluding land and building and the items specified by the Ministry of Small Scale Industries vide its
notification No.S.O.1722(E) dated October 5, 2006 :
Rs.....Lacs
2. **For Service Enterprises:** Investment in equipment (original cost excluding land and building and
furniture, fittings and other items not directly related to the service rendered or as may be notified under the MSMED
Act, 2006:
Rs.....Lacs

(Strike off whichever is not applicable)

The above investment of Rs.....Lacs is within permissible limit of
Rs.....Lacs forMicro / Small (Strike off which is not applicable)
Category under MSMED Act 2006.

Or

The company has been graduated from its original category {Micro/ Small} (Strike off which is not
applicable) and the date of graduation of such enterprise from its original category is
(dd/mm/yyyy) which is within the period of 3 years from the date of graduation of such
enterprise from its original category as notified vide S.O. No. 3322(E) dated 01.11.2013 published
in the gazette notification dated 04.11.2013 by Ministry of MSME.

Date:

(Signature)

Name-

Membership number-

Seal of Chartered Accountant

68000-102-02-2
DRAWING NO. ON 00039

ALL DIMENSIONS ARE IN MILLIMETRES. FOR TOLERANCES OF UNTOLERANCED DIMENSIONS DURING MANUFACTURE REFER RELEVANT QCP / QP

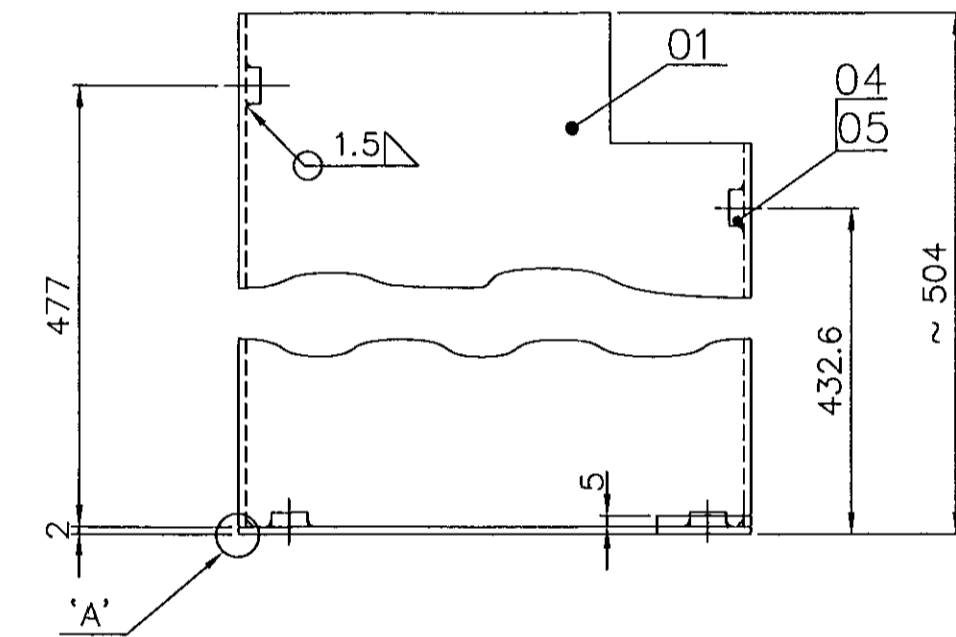
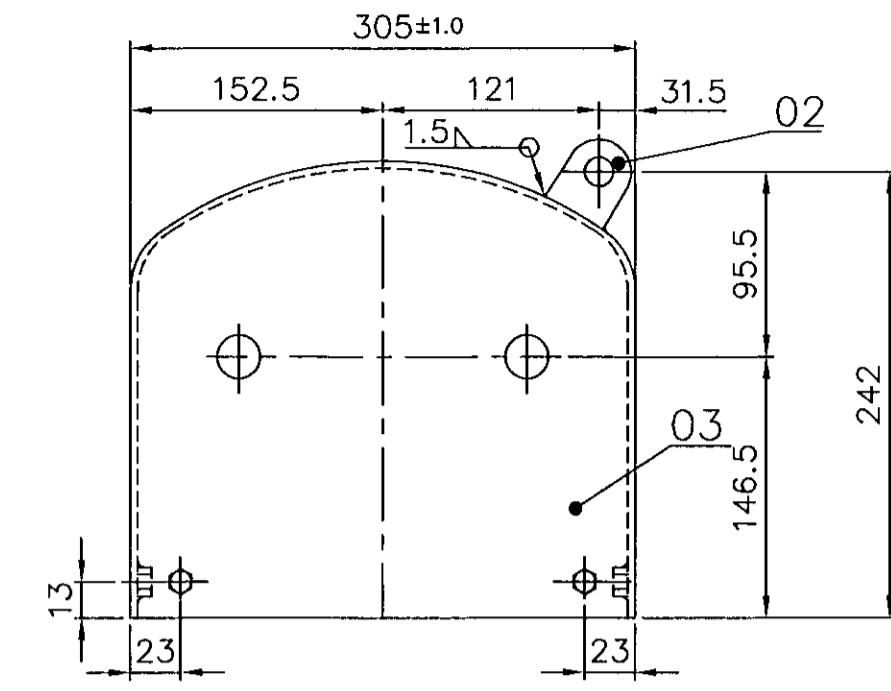
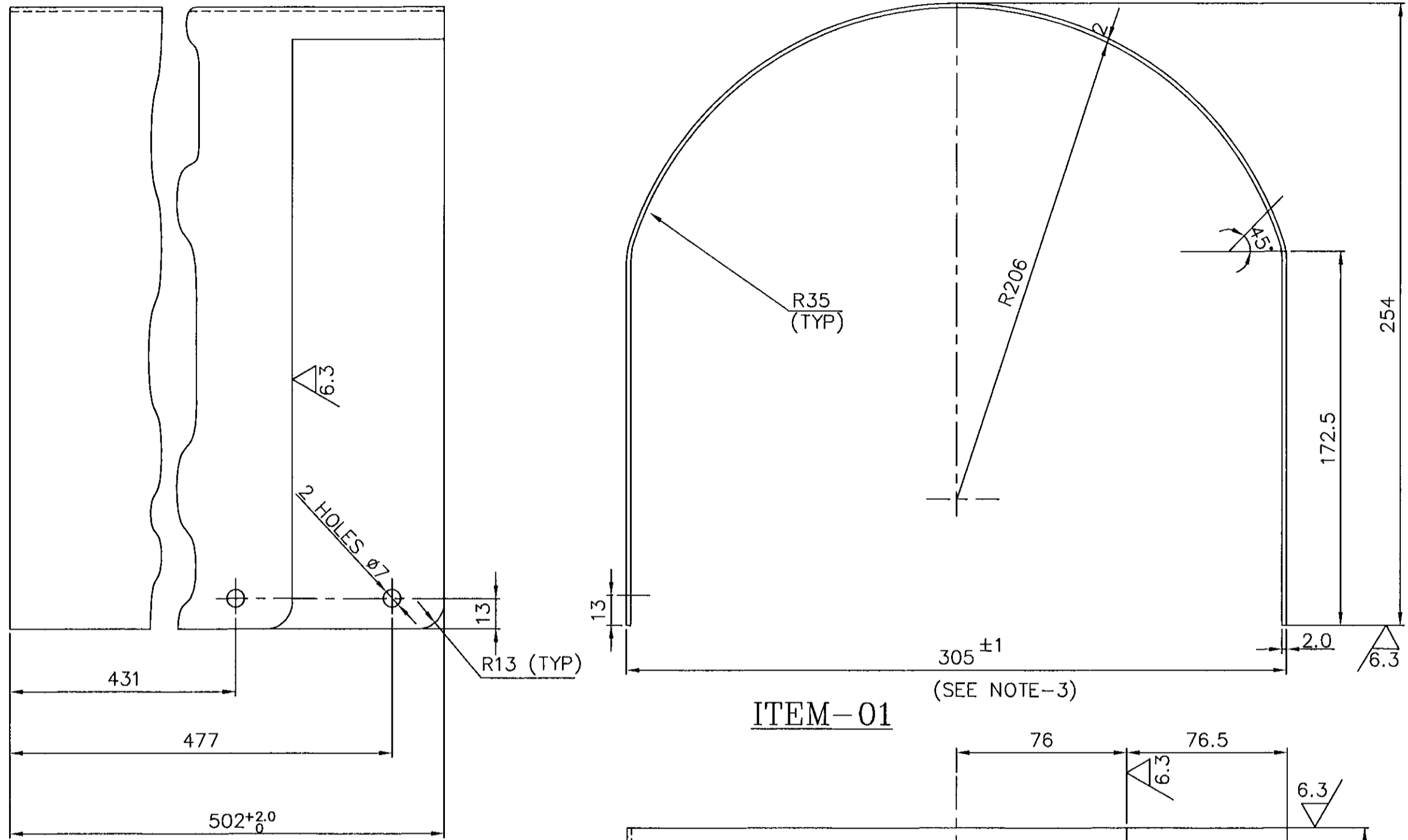

- NOTE: -**
1. SHARP CORNERS ARE TO BE ROUNDED OFF.
 2. SURFACES SHOULD BE FREE FROM BENDS AND THEY SHOULD BE PERFECTLY STRAIGHT & SMOOTH.
 3. THIS DIMENSION IS CRITICAL. INSPECTOR SHOULD CHECK THIS DIMENSION ON ALL PIECES.
 4. FOR QUALITY REQUIREMENTS REFER LATEST APPLICABLE QUALITY PROCEDURES.

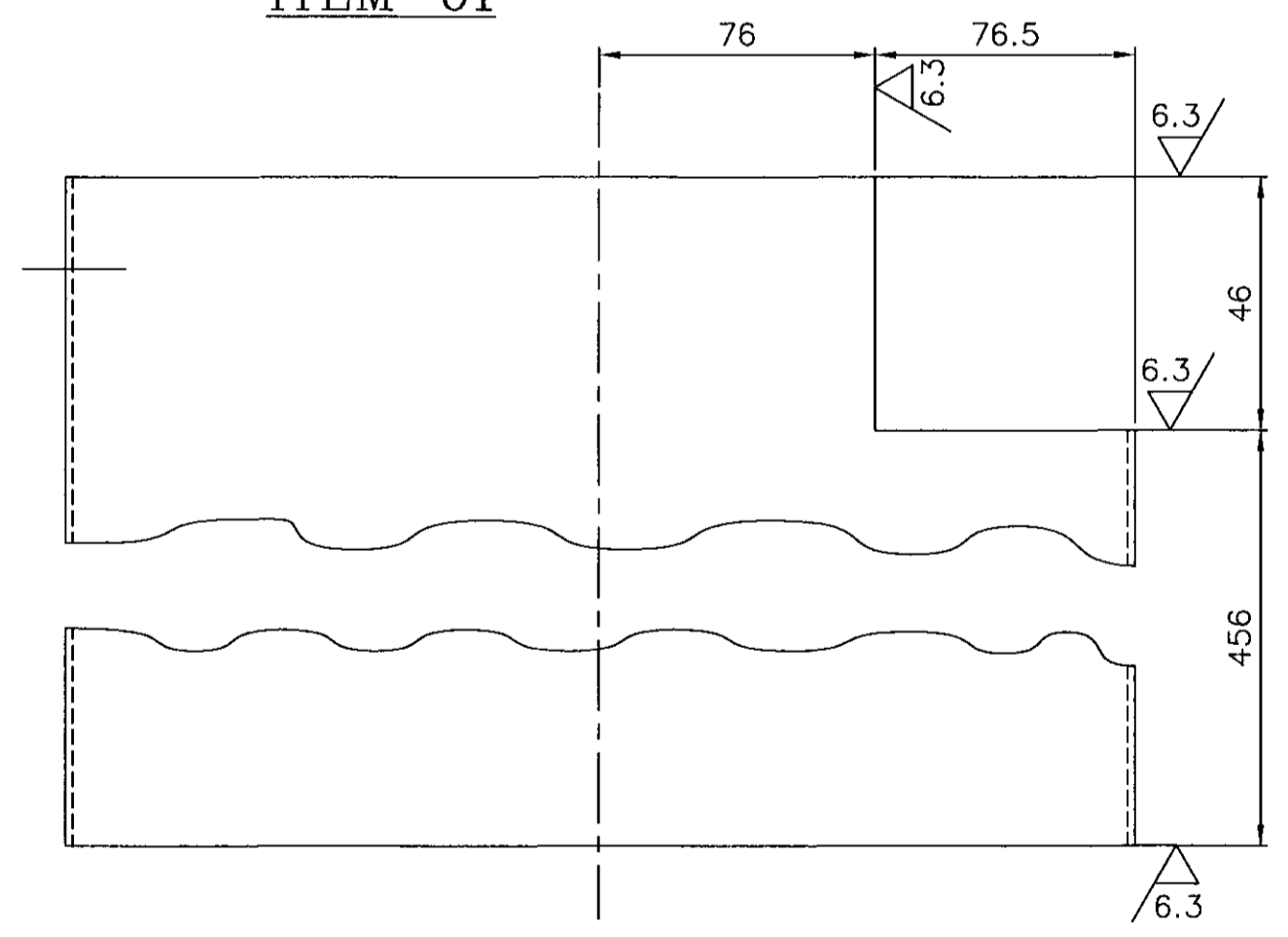
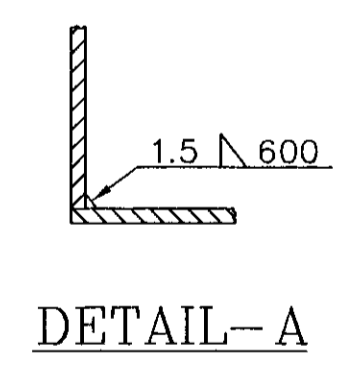
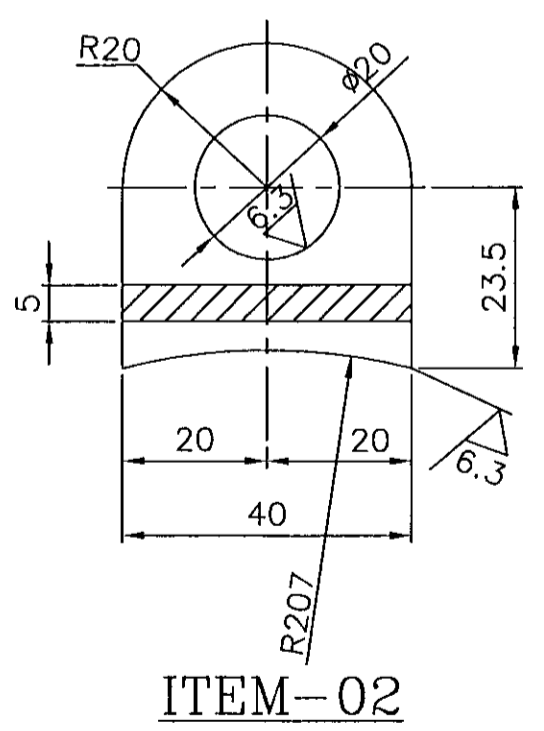

PART CODE : 842020115800

No OF	DESCRIPTION	MATL CODE	MATL SPECN	HEAT TREATMENT	SCRAP SORT	NET WT (kg)	GROSS WT (kg)	DRAWING No	ITEM No															
	TYPE OF PRODUCT OR NAME OF CUSTOMER/PROJECT																							
	<table border="1"> <tr> <td>DRN</td> <td>V. Arumugham</td> <td>SIGN</td> <td>DATE</td> <td>NO. OF VAR.</td> </tr> <tr> <td>CHD</td> <td>K. Pritharan</td> <td></td> <td></td> <td></td> </tr> <tr> <td>APPD</td> <td>S. Natarajan</td> <td></td> <td></td> <td></td> </tr> </table>									DRN	V. Arumugham	SIGN	DATE	NO. OF VAR.	CHD	K. Pritharan				APPD	S. Natarajan			
DRN	V. Arumugham	SIGN	DATE	NO. OF VAR.																				
CHD	K. Pritharan																							
APPD	S. Natarajan																							
DEPT	SB	SCALE	WEIGHT (KG).	REFERENCE INFORMATIONS																				
365-120		NTS	6.288	L-130908																				
CODE	330			DRAWING NO.																				
TITLE			CARD CODE	REV																				
GUARD			U 01	2-20-201-00039 14																				

REV	DATE	ALTERED
14	11.06.01	CHD & APPD
ZONE DRG.UPDATED AND REDRAWN.		
DCN: SB: 1298		

CAUTION: The information on this document is the property of BHARAT HEAVY ELECTRICALS LTD. It must not be used directly or indirectly in any way detrimental to the interest of the company.

DRAWING NO. 2-20-201-00257

ALL DIMENSIONS ARE IN MILLIMETRES. FOR TOLERANCES OF UNTOLERANCED DIMENSIONS DURING MANUFACTURE REFER RELEVANT QCP / $\sqrt{12.5}$ (S)

$\sqrt{12.5}$ (S)

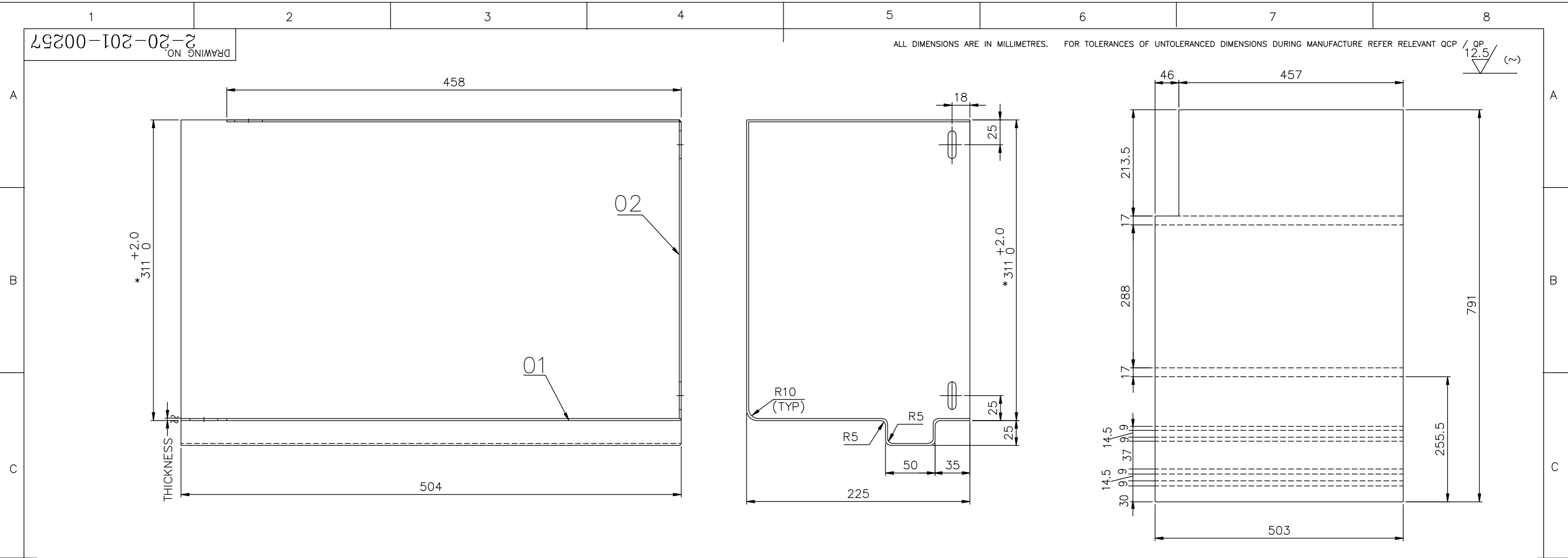

DEVELOPMENT OF ITEM 01

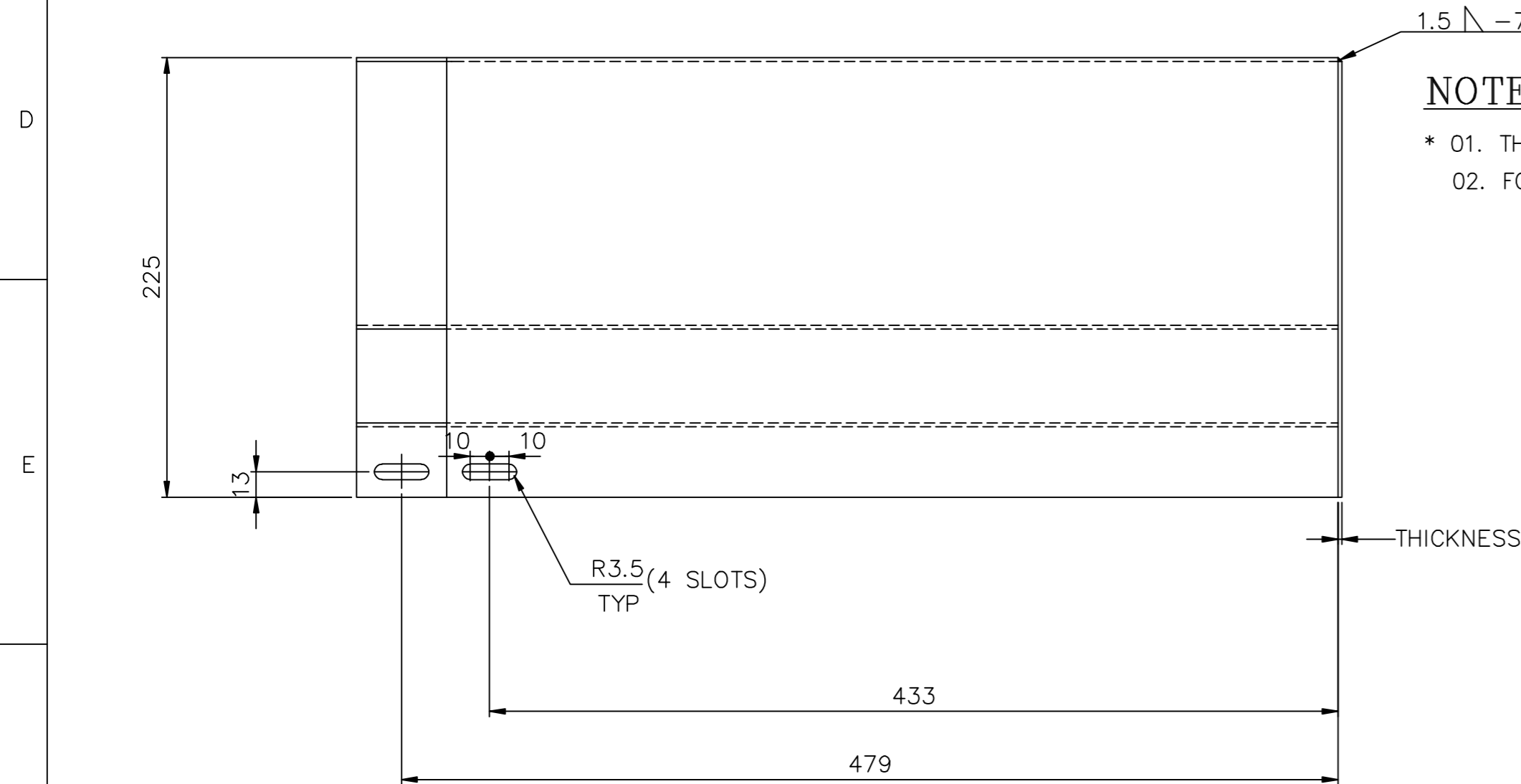

1.5 $\sqrt{760}$

NOTES: -

- * 01. THIS DIMENSION IS CRITICAL INSPECTOR TO CHECK ON ALL PIECES.
- 02. FOR QUALITY REQUIREMENTS REFER LATEST APPLICABLE QUALITY PROCEDURES.

PART CODE : 842020136700

NO OFF	DESCRIPTION	MATL CODE	MATL SPECN	HEAT TREATMENT	SCRAP SORT	NET WT (kg)	GROSS WT (kg)	DRAWING NO	ITEM NO.
	SHEET 2.0 MM / SHEET 1.6 MM	150111040000 / 150110760000	IS 513-D					4-20-201-01413	01
	SHEET 2.0 MM / SHEET 1.6 MM	150111040000 / 150110760000	IS 513-D					4-20-201-01413	02

No OFF	DESCRIPTION	MATL CODE	MATL SPECN	HEAT TREATMENT	SCRAP SORT	NET WT (kg)	GROSS WT (kg)	DRAWING No	ITEM No
--------	-------------	-----------	------------	----------------	------------	-------------	---------------	------------	---------

CAUTION: The information on this document is the property of BHARAT HEAVY ELECTRICALS LTD. It must not be used directly or indirectly in any way detrimental to the interest of the company.

TYPE OF PRODUCT OR NAME OF CUSTOMER/PROJECT										
BHARAT HEAVY ELECTRICALS LTD., UNIT: HIGH PRESSURE BOILER PLANT. TIRUCHIRAPALLI - 620014.						DRN	V. Anumugham.	SIGN	DATE	NO. OF VAR.
						CHD	K. Sriharan.			
						APPD	S. Natarajan.			
DEPT	SB	SCALE	WEIGHT (KG).	REFERENCE INFORMATION			NO. OF ITEMS			
365-125		NTS	5.873							
CODE	330	TITLE		CARD CODE	DRAWING NO.	REV				
		BOTTOM COVER		U 01	2-20-201-00257	07				

REV	DATE	ALTERED	J.S
07	12.03.11	CHD & APPD	K.S
ZONE SHEET 1.6 MM INTRODUCED.			
DCN : SB : 801133 / 5012916			

2-V-0000-14336
DRAWING NO.

ALL DIMENSIONS ARE IN MILLIMETRES. FOR TOLERANCES OF UNTOLERANCED DIMENSIONS DURING MANUFACTURE REFER RELEVANT QCP / QP

SL.No.	DRAWING No.	MATL. CODE	∅D $\begin{smallmatrix} +2 \\ 0 \end{smallmatrix}$	L $\begin{smallmatrix} +4 \\ 0 \end{smallmatrix}$	NET WT (Kg)	APPLICABLE VALVE SIZES
01	2-V-N298-14336/1	96 465 276 0000	122	22	0.33	2-C150-GV
02	2-V-F602-14336/1	96 465 277 0000	135	27	0.42	3-C600-GV
03	2-V-2885-14336/1	96 465 278 0000	142	23	0.43	3-C300-RV
04	2-V-N289-14336/1	96 465 279 0000	148	20	0.43	3-C150-FV,3-C150-GV
05	2-V-N255-14336/1	96 465 280 0000	158	20	0.48	3-C300-GV
06	2-V-F603-14336/1	96 465 281 0000	166	33	0.63	4-C600-GV
07	2-V-5171-14336/1	96 465 282 0000	168	23	0.56	3-C300-FV
08	2-V-N294-14336/1	96 465 283 0000	176	35	0.71	4-C150-GV
09	2-V-2886-14336/1	96 465 284 0000	180	33	0.71	4-C300-RV
10	2-V-5177-14336/1	96 465 285 0000	188	18	0.62	4-C150-FV
11	2-V-N251-14336/1	96 465 286 0000	206	30	0.85	4-C300-GV
12	2-V-F604-14336/1	96 465 287 0000	227	43	1.14	6-C600-GV
13	2-V-N248-14336/1	96 465 288 0000	230	30	1.04	6-C150-GV,6-C300-GV
14	2-V-5176-14336/1	96 465 289 0000	232	25	0.98	6-C150-FV
15	2-V-2887-14336/1	96 465 290 0000	236	24	0.99	6-C300-RV
16	2-V-5173-14336/1	96 465 291 0000	242	39	1.22	6-C300-FV
17	2-V-N271-14336/1	96 465 292 0000	282	39	1.55	8-C150-GV
18	2-V-N244-14336/1	96 465 293 0000	288	33	1.52	8-C300-FV,8-C300-GV,8-C600-GV
19	2-V-5170-14336/1	96 465 294 0000	292	30	1.44	8-C150-FV
20	2-V-2888-14336/1	96 465 295 0000	297	33	1.60	8-C300-RV
21	2-V-N267-14336/1	96 465 296 0000	336	40	2.09	10-C150-GV
22	2-V-F609-14336/1	96 465 297 0000	344	35	2.09	10-C600-GV
23	2-V-N235-14336/1	96 465 298 0000	357	43	2.37	10-C300-FV,10-C300-GV
24	2-V-Z018-14336/1	96 465 299 0000	386	63	3.08	12-C300-FV
25	2-V-N903-14336/1	96 465 300 0000	416	45	3.10	12-C300-GV
26	2-V-N631-14336/1	96 465 301 0000	432	58	3.59	12-C300-GV
27	2-V-N593-14336/1	96 465 302 0000	460	50	3.79	14-C300-GV
28	2-V-N594-14336/1	96 465 303 0000	492	47	4.18	16-C300-GV,16-C300-FV
29	2-V-N575-14336/1	96 465 304 0000	540	80	5.79	18-C150-GV
30	2-V-N822-14336/1	96 465 305 0000	593	58	6.10	20-C150-FV,20-C150-GV
31	2-V-N595-14336/1	96 465 306 0000	648	60	7.10	20-C300-GV
32	2-V-N805-14336/1	96 465 307 0000	698	58	8.08	24-C150-GV

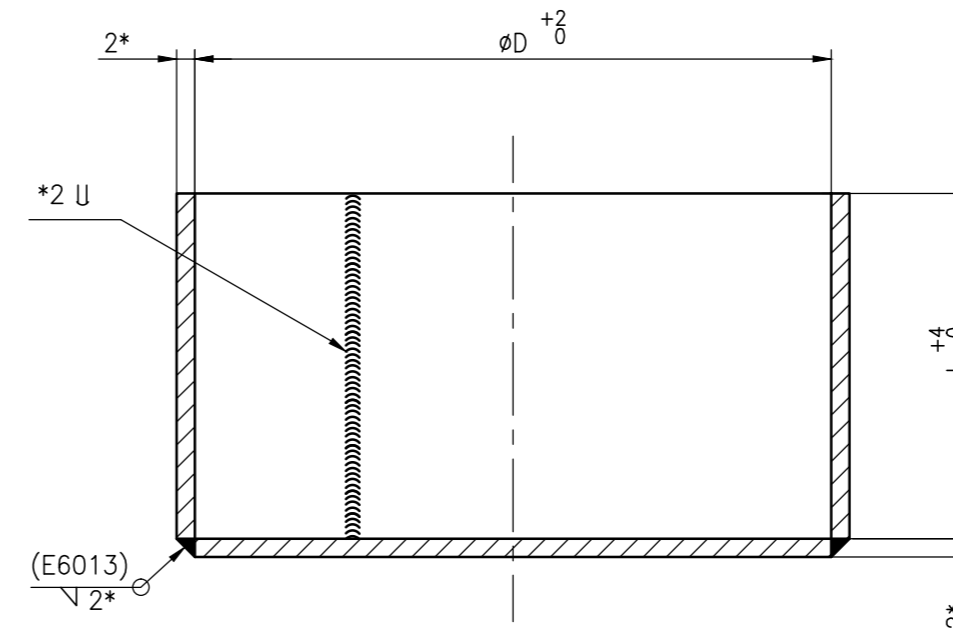

NOTE:

- 1.MATERIAL SPECIFICATION: IS 1079 Gr.St 34 (BMC10).
- 2.*SHEET THICKNESS 1.6 ALSO ACCEPTABLE.

REV 01	DATE 16.03.13	ALTERED CHD & APPD	P.NALLATHAMBI S.S.K. & M.R.K
NOTE No.2 ADDED.			
DCP: 801481			

CAUTION: The information on this document is the property of BHARAT HEAVY ELECTRICALS LTD. It must not be used directly or indirectly in any way detrimental to the interest of the company.

No OFF	DESCRIPTION	MATL CODE	MATL SPECN	HEAT TREATMENT	SCRAP SORT	NET WT (kg)	GROSS WT (kg)	DRAWING No	ITEM No
-	-	-	-	-	-	-	-	-	-
TYPE OF PRODUCT OR NAME OF CUSTOMER/PROJECT									
BHARAT HEAVY ELECTRICALS LTD., UNIT: HIGH PRESSURE BOILER PLANT. TIRUCHIRAPALLI -620014.				DRN	R.RAJKUMAR	SIGN	DATE 08.06.99	NO.OF VAR.	
				CHD	R.L.NARAYANAN		08.06.99		
				APPD	M.RAJAKUMAR		08.06.99		
DEPT VL	SCALE NTS	WEIGHT (KG).	REFERENCE INFORMATION	NO. OF ITEMS					
CODE 320		REF. TABLE	CAD REF: C214336						
TITLE							CARD CODE	DRAWING NO.	REV
METALLIC END COVER (FABRICATED)							U 01	2-V-0000-14336	01

2-V-0000-15483/19
DRAWING NO.

ALL DIMENSIONS ARE IN MILLIMETRES. FOR TOLERANCES OF UNTOLERANCED DIMENSIONS DURING MANUFACTURE REFER RELEVANT QCP / QP

SL.No.	DRAWING No.	MATL. CODE	ØD ⁺² / ₀	L ⁺⁴ / ₀	NET WT (Kg)	APPLICABLE VALVE SIZES
A 01	2-V-G041-15483/2	964530010000	92.5	30	0.24	65/1500 GL,RE
02	2-V-W049-15483/2	964530020000	98.5	30	0.27	65/1500 WG
03	2-V-W001-15483/2	964530030000	102.5	30	0.28	65/2500 WG,GL,RE,65/1500 NR
04	2-V-G004-15483/2	964530040000	106.5	40	0.35	65/3500 GL,80/1500 GL,RE
05	2-V-L161-15483/2	964530050000	112.5	40	0.38	80/1500 NR,65/2500 NR
B 06	2-V-G145-15483/2	964530060000	117.5	40	0.40	80/2500/ GL,80/1500 WG
07	2-V-W345-15483/2	964530070000	122.5	50	0.49	65/3500 RE,80/2500 WG
08	2-V-L025-15483/2	964530080000	127.5	40	0.45	80/3500 RE,80/2500 NR
09	2-V-G001-15483/2	964530090000	137.5	50	0.57	100/1500 RE,GL,WG,100/2500 RE,GL
10	2-V-L053-15483/2	964530100000	142.5	40	0.53	100/1500 NR
11	2-V-W369-15483/2	964530110000	147.5	40	0.56	80/3500 WG
12	2-V-W002-15483/2	964530120000	152.5	50	0.66	100/2500 WG,NR
13	2-V-W353-15483/2	964530130000	158	75	0.69	125/2500 WG
14	2-V-W441-15483/2	964530140000	163	50	0.73	125/1500 WG,RE
15	2-V-W065-15483/2	964530150000	188	75	1.13	150/2500 WG,NR
16	2-V-W057-15483/2	964530160000	193	75	1.17	150/1500 WG,NR
17	2-V-G002-15483/2	964530170000	205	75	1.28	150/2500 RE,GL
C 18	2-V-W113-15483/2	964530180000	238	75	1.58	200/1500 WG,NR
19	2-V-L002-15483/2	964530190000	243	100	1.93	200/2500 NR
20	2-V-W003-15483/2	964530200000	248	100	1.98	200/2500 WG
21	2-V-L177-15483/2	964530210000	287.5	100	2.43	250/2500 NR,WG,250/1500 WG
22	2-V-L129-15483/2	964530220000	293	100	2.50	250/1500 NR
D 23	2-V-W061-15483/2	964530230000	340	100	3.10	300/1500 WG,NR
24	2-V-W005-15483/2	964530240000	354.5	100	3.29	300/2500 WG,NR
25	2-V-W117-15483/2	964530250000	383	100	3.69	350/1500 WG
26	2-V-L121-15483/2	964530260000	393	100	3.84	350/1500 NR
27	2-V-W465-15483/2	964530270000	403	100	3.99	350/2000 WG
28	2-V-L029-15483/2	964530280000	418.5	100	4.22	300/2000 ELB,350/2500 NR
29	2-V-W006-15483/2	964530290000	423	150	5.33	350/2500 WG
30	2-V-L081-15483/2	964530300000	443	150	5.70	350/2500 SCH
31	2-V-L113-15483/2	964530310000	448	100	4.68	300/2000 ELB,350/2750 WG
E 32	2-V-W069-15483/2	964530320000	473	150	6.25	400/2500 WG
33	2-V-G137-15483/2	964530330000	482	150	6.43	400/2500 RE,18"/150C GV
34	2-V-W457-15483/2	964530340000	503	100	5.60	450/1500 WG
35	2-V-W073-15483/2	964530350000	533	175	8.10	450/2500 WG

SL.No.	DRAWING No.	MATL. CODE	ØD ⁺² / ₀	L ⁺⁴ / ₀	NET WT (Kg)	APPLICABLE VALVE SIZES
36	2-V-W515-15483/2	964530360000	558	175	8.65	450/2000 WG
37	2-V-W417-15483/2	964530370000	613	150	9.17	600/1500 WG
38	2-V-W077-15483/1	964531150000	563	175	8.77	500/2750 WG
39	2-V-W505-15483	964531160000	197	75	1.21	150/2750 WG
40	2-V-L033-15483/2	964531740000	519	200	8.33	450/2500 SCH
41	2-V-L169-15483/1	964531750000	463	150	6.09	400/2500 SCH
42	2-V-W393-15483/1	964531760000	458	100	4.86	400/1500 WG
43	2-V-L089-15483/1	964531770000	168	80	1.02	125/1500 & 125/2500 SCH
44	2-V-W752-15483/1	964533550000	593	175	9.20	500/2850 SPL WG
45	2-V-W021-15483/1	964533590000	325	100	2.94	300/2500 WG (FOR P91)
46	2-V-K616-15483/3	964650090000	638	100	9.2	24"/150C GV
47	2-V-N589-15483/3	964650110000	372	100	3.4	14"/150C GV
48	2-V-N370-15483/3	964650100000	532	100	6.4	20"/150C GV
49	2-V-N594-15483/3	964650120000	440	100	4.4	16"/300C GV
50	2-V-3204-15483/1	964651370000	790	70	10.5	700MM/1500 RHID
51	2-V-P366-15483/1	964652090000	311	40	1.8	10"/C300-RV
52	2-V-WA81-15483/2	964660030000	685	200	12.6	550/3000 SPL GV
53	2-V-NG24-15483/1	964653650000	486	100	5.3	18/300-GV
54	2-V-3319-15483/1	964654100000	869	70	12.3	800/1500-RHID
55	2-V-P560-15483/1	964654140000	356	40	2.3	300/300-RV
56	2-V-3314-15483/1	964661000000	970	125	17.6	800/600-RHID
57	2-V-U482-15483/1	964661010000	882	110	14.6	700/1500-RHID
58	2-V-F999-15483	964655050000	1023	80	16.95	38"/600C GV, 38"/300C SCV

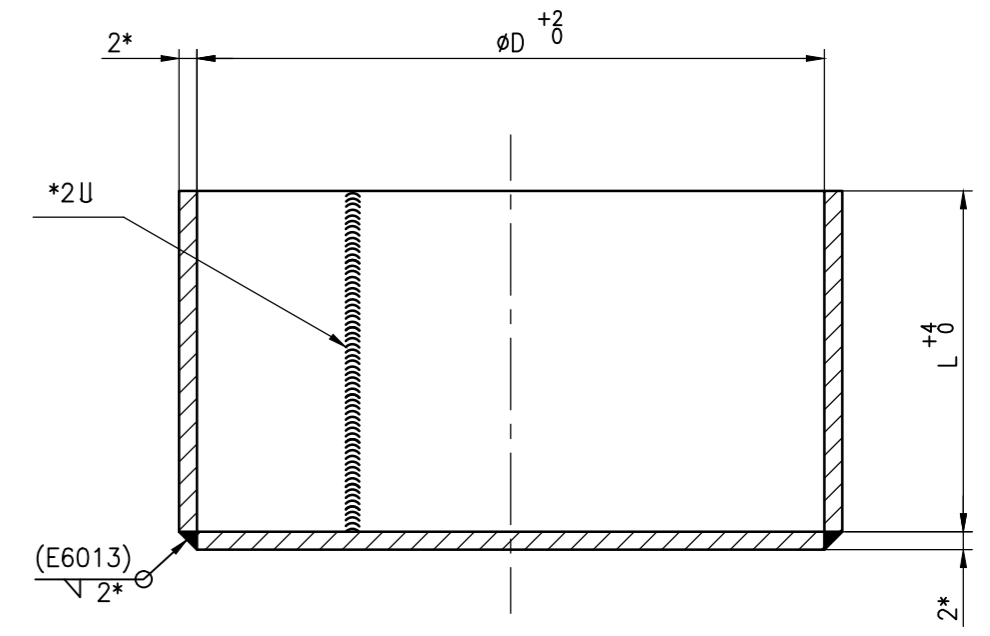

NOTE:
 1. MATERIAL SPECIFICATION: IS 1079 Gr."O" CERTIFY.
 2. *SHEET THICKNESS 1.6 ALSO ACCEPTABLE.

No OFF	DESCRIPTION	MATL CODE	MATL SPECN	HEAT TREATMENT	SCRAP SORT	NET WT (kg)	GROSS WT (kg)	DRAWING No	ITEM No
-	-	-	-	-	-	-	-	-	-

TYPE OF PRODUCT OR NAME OF CUSTOMER/PROJECT		BHARAT HEAVY ELECTRICALS LTD., UNIT: HIGH PRESSURE BOILER PLANT. TIRUCHIRAPALLI -620014.		DRN R.RAJKUMAR	SIGN	DATE 08.06.99	NO.OF VAR.	
DEPT VL	SCALE NTS	WEIGHT (KG). REF. TABLE	REFERENCE INFORMATIONS					NO. OF ITEMS
CODE 320	TITLE METALLIC END COVERS (FABRICATED)	CARD CODE U 01	DRAWING NO. 2-V-0000-15483	REV 19				

REV 19	DATE 16.07.13	ALTERED CHD & APPD	VB SSK & KRS	REV 18	DATE 16.03.13	ALTERED CHD & APPD	P.NALLATHAMBI S.S.K. & M.R.K	REV 17	DATE 04.04.12	ALTERED CHD & APPD	VB SSK & KRS
SL. Nos.58 INCLUDED				NOTE No.2 ADDED. DCP: 801481				SL. Nos.56 & 57 INCLUDED			

1	2	3	4	5	6	7	8
---	---	---	---	---	---	---	---

Size A2

CAUTION: The information on this document is the property of BHARAT HEAVY ELECTRICALS LTD. It must not be used directly or indirectly in any way detrimental to the interest of the company.

22267-0000-V-3
DRAWING NO.

SL. NO	DRAWING NO	MATL CODE	$\phi D \begin{smallmatrix} +2 \\ 0 \end{smallmatrix}$	$L \begin{smallmatrix} +4 \\ 0 \end{smallmatrix}$	WEIGHT	SIZE
01	3-V-L915-22267/00	964605530000	236	83	1.65	8"/300C
02	3-V-L929-22267/00	964605540000	343	83	2.5	12"/150C
03	3-V-L943-22267/00	964605550000	432	83	4.07	16"/150C
04	3-V-L957-22267/00	964605560000	646	83	7.78	24"/150C
05	3-V-L820-22267/00	964605570000	533	100	6.13	18"/600C
06	3-V-L825-22267/00	964605580000	187	53	0.92	6"/300C
07	3-V-L841-22267/00	964605590000	297	53	1.82	10"/300C
08	3-V-L857-22267/00	964605600000	352	53	2.44	12"/300C
09	3-V-L873-22267/00	964605610000	192	53	0.96	6"/600C
10	3-V-L889-22267/00	964605620000	397	53	2.98	14"/600C
11	3-V-L893-22267/00	964606420000	358	53	2.6	14"/150C(REDCER)
12	3-V-L805-22267/00	964606430000	459	100	5.9	18"/150REDUCER
13	3-V-L890-22267/00	964606520000	561	70	5.825	22"/18"REDUCER
14	3-V-L891-22267/00	964606530000	408	25	2.555	16"/18"REDUCER
15	3-V-L725-22267/00	964606540000	573	50	5.467	20"/300C
16	3-V-L751-22267/00	964606550000	713	70	8.737	28"/26"REDUCER
17	3-V-L752-22267/00	964606560000	702	75	8.681	24"/600C
18	3-V-L984-22267/00	964606570000	385	40	2.591	16"/300C
19	3-V-L783-22267/00	964606580000	430	85	4.09	16"/600C
20	3-V-L793-22267/00	964606980000	934	100	15.3	32"/600C
21	3-V-L789-22267/00	964606990000	854	100	13.1	32"/150C
22	3-V-L507-22267/00	964607450000	319	60	2.3	10"/600C
23	3-V-L508-22267/00	964607460000	221	30	1.0	8"X10"REDUCER
24	3-V-L794-22267/00	964607930000	944	150	19.5	32"/600C
25	3-V-L985-22267/00	964608140000	390	40	2.68	16"/300C
26	3-V-LA41-22267/00	964620310000	950	150	19	32"/900C

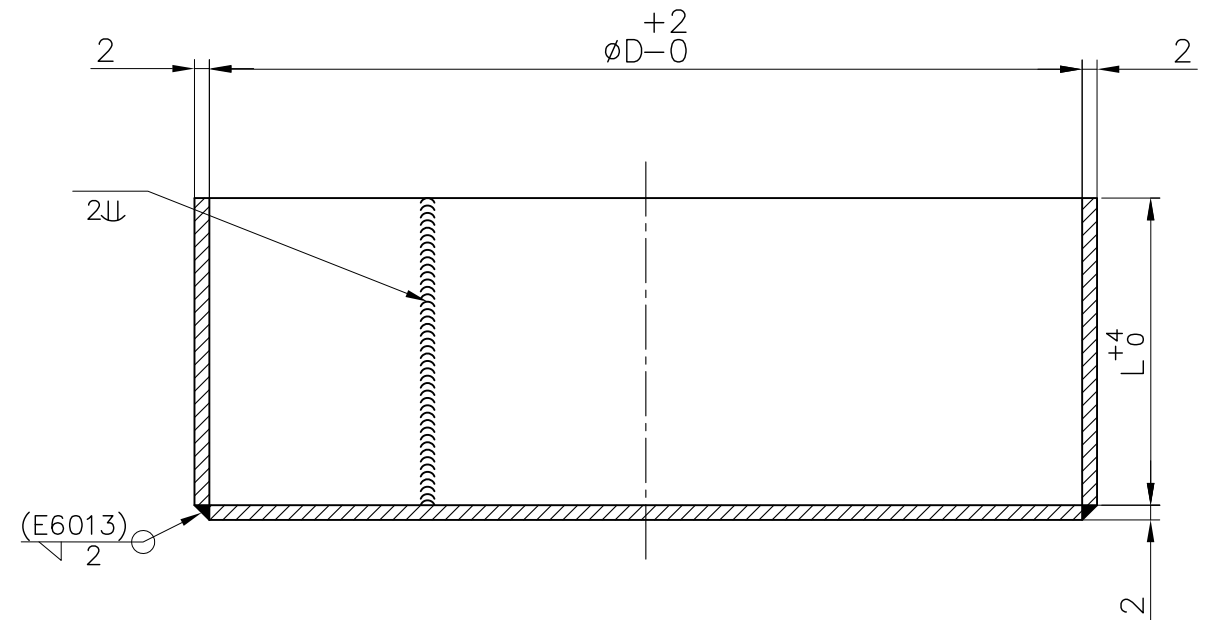

NOTE:

MATERIAL SPECIFICATION IS 1079 GR.ST 34.

NO OFF	DESCRIPTION	MATL CODE	MATL SPECN	HEAT TREATMENT	SCRAP SORT	NET WT (kg)	GROSS WT (kg)	DRAWING No	ITEM No
--------	-------------	-----------	------------	----------------	------------	-------------	---------------	------------	---------

TYPE OF PRODUCT OR NAME OF CUSTOMER/PROJECT

BHARAT HEAVY ELECTRICALS LTD., UNIT: HIGH PRESSURE BOILER PLANT. TIRUCHIRAPALLI -620014. 365-121	DRN	NAME	SIGN	DATE	NO. OF VAR.
	CHD				
	APPD				

DEPT VL	SCALE NTS	WEIGHT (KG) ---	REFERENCE INFORMATIONS	NO. OF ITEMS
---------	-----------	-----------------	------------------------	--------------

TITLE METALLIC END COVERS (FABRICATED)	CARD CODE U 01	DRAWING NO. 3-V-0000-22267	REV 08
--	----------------	----------------------------	--------

REV 08	DATE 01.02.13	ALTERED CHD & APPD	JALAL MRK
--------	---------------	--------------------	-----------

S.No. 25 ADDED.

CAUTION: The information on this document is the property of BHARAT HEAVY ELECTRICALS LTD. It must not be used directly or indirectly in any way detrimental to the interest of the company.

DRAWING NO. 3-V-0000-22633

SL.NO.	DRAWING NUMBER	MATERIAL CODE	$\phi D \begin{smallmatrix} +2 \\ 0 \end{smallmatrix}$	$L \begin{smallmatrix} +4 \\ 0 \end{smallmatrix}$	WEIGHT	SIZE
01	3-V-L752-22633/00	964608200000	712	130	17.68	24"/600CL
02	3-V-L753-22633/00	964620070000	762	80	10.3	24"/600CL
03	3-V-L472-22633/00	964620210000	982	100	18.0	32"/600CL
04	3-V-L475-22633/00	964620220000	584	100	4.5	18"/600CL

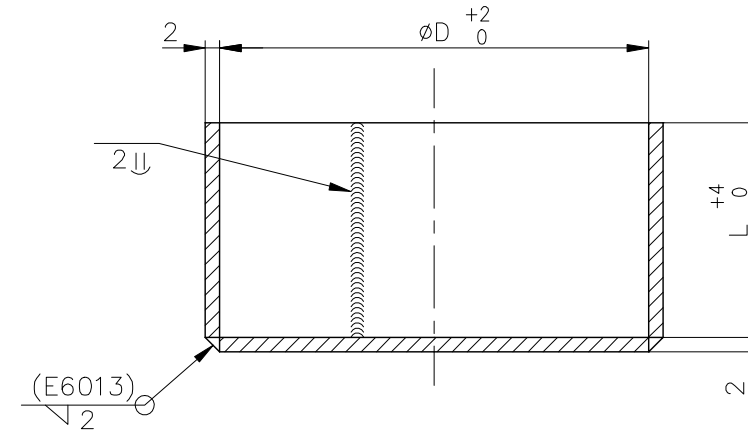

NOTES:

1. MATERIAL SPECIFICATION – IS 1079 GR.ST34
2. APPLICABLE LATEST QUALITY PROCEDURE SHALL BE FOLLOWED IN ALL RESPECTS.

NO OFF	DESCRIPTION	MATL CODE	MATL SPECN	HEAT TREATMENT	SCRAP SORT	NET WT (kg)	GROSS WT (kg)	DRAWING No	ITEM No
--------	-------------	-----------	------------	----------------	------------	-------------	---------------	------------	---------

TYPE OF PRODUCT
OR NAME OF
CUSTOMER/PROJECT

	BHARAT HEAVY ELECTRICALS LTD.,		DRN	M P S	SIGN	M P S	DATE	01.05.98	NO.OF VAR.
	UNIT: HIGH PRESSURE BOILER PLANT.		CHD	P R K	P R K	01.05.98			
	TIRUCHIRAPALLI-620014.		APPD	S C S	S C S	01.05.98			

DEPT	VL	SCALE	WEIGHT (KG).	REFERENCE INFORMATION	NO. OF ITEMS
CODE	320	NTS.	—		

TITLE	CARD CODE	DRAWING NO.	REV
METALLIC END COVERS (FABRICATED)	U 01	3-V-0000-22633	03

REV	DATE	ALTERED	Jalaludeen.K.
03	25.10.2010	CHD & APPD	PRK

SERIAL NUMBER 03 AND 04 ADDED.

CAUTION: The information on this document is the property of BHARAT HEAVY ELECTRICALS LTD. It must not be used directly or indirectly in any way detrimental to the interest of the company.

3-V-0000-23461/8
DRAWING NO.

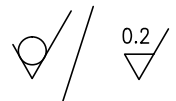

SL. NO.	DRAWING NO.	COMPONENT CODE	ϕD^0	L^0	WT (kg)	VALVE SIZE
01	3-V-N590-23461/1	964536440000	426	100	4.4	16"-150C
02	3-V-N593-23461/1	964536450000	387	90	3.6	14"-300C
03	3-V-N595-23461/1	964536460000	542	125	7.0	20"-300C
04	3-V-V137-23461/1	964535420000	359	100	4.0	300/1500C
05	3-V-V329-23461/1	964535430000	304	100	2.7	250/2500C
06	3-V-V465-23461/1	964535440000	545	200	5.4	500/3500C
07	3-V-C520-23461/1	964536900000	84	30	0.3	65/1500C
08	3-V-C524-23461/1	964536910000	184	75	1.1	150/1500C
09	3-V-C526-23461/1	964536920000	234	75	1.6	200/1500C
10	3-V-N826-23461/2	964650010000	850	90	12.4	32"/150C
11	3-V-W587-23461/1	964535770000	256	100	2.05	200/2750C
12	3-V-W551-23461/1	964535890000	408	50	3.06	500/2750C
13	3-V-V377-23461/1	964535910000	466	150	6.13	350/2500 & 400/2500
14	3-V-3318-23461/1	964653630000	827	80	11.6	700/1500

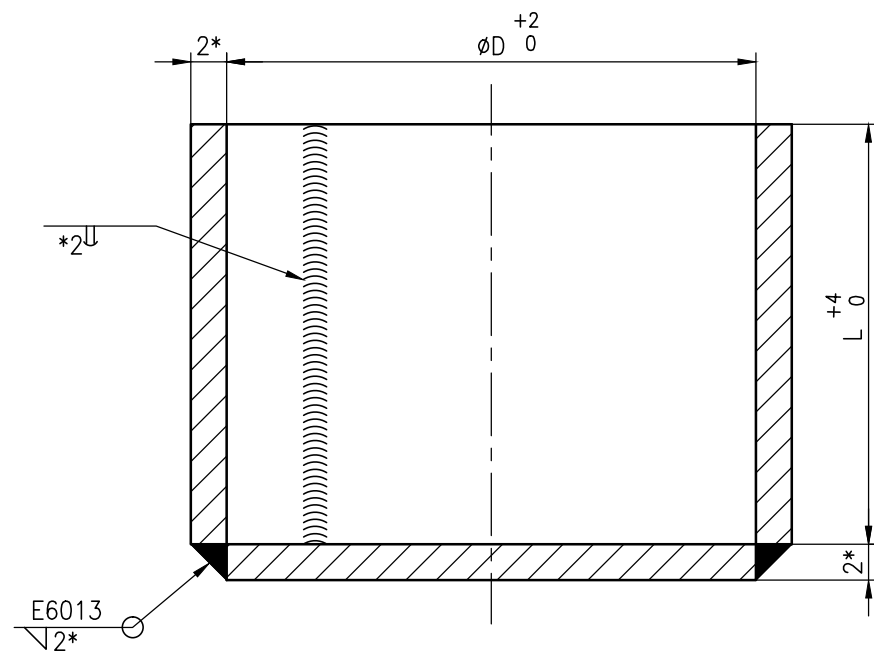

NOTE:-

- 1.MATERIAL SPECIFICATION :- IS1079 Gr St 34 (BMC 10)
2. *SHEET THICKNESS 1.6 ALSO ACCEPTABLE.

SL No	DRAWING No	COMP CODE	MATL SPECN	HEATTREATMENT	SCRAP SORT	NET WT (kg)	GROSS WT (kg)
-	-	-	-	-	-	-	-

REV	DATE	ALTERED	P.NALLATHAMBI	REV	DATE	ALTERED	:GANESH
8	16.03.13	CHD & APPD	S.S.K. & M.R.K	7	24.02.10	CHD & APPD	:MRK
NOTE No.2 ADDED.				SL. No.14 INCLUDED.			
DCP: 801481							

CAUTION: The information on this document is the property of BHARAT HEAVY ELECTRICALS LTD. It must not be used directly or indirectly in any way detrimental to the interest of the company.

TYPE OF PRODUCT OR NAME OF CUSTOMER/PROJECT								
 365-121	BHARAT HEAVY ELECTRICALS LTD.,			DRN	V.BAIRAVAN	SIGN	DATE	NO.OF VAR.
	UNIT: HIGH PRESSURE BOILER PLANT.			CHD	K.RAJASEKARAN		24.12.04	
	TIRUCHIRAPALLI-620014.			APPD	M.RAJAKUMAR		24.12.04	
DEPT	VL	SCALE	WEIGHT (KG).	REFERENCE INFORMATION				NO. OF ITEMS
CODE	320	N T S	REF.TABLE	CAD REF:C323461				
TITLE				CARD CODE	DRAWING NO.			REV
METALLIC END COVERS (FABRICATED)				U 01	3-V-0000-23461			8

Techno-Commercial/Unprice Bid Annexure to Enquiry No.1415-164 Dated 19.01.2015, Due date 10.02.2015

Enq Si. No.	Code	Description of material	Drg No	Quoted (Yes/No)	Qty (Nos)	Unit Basic Price, Rs. per No.
1	964652760000	METAL. END COVER-W001	2V000014336	Yes/No	1000	Please see price bid
2	964652770000	METAL. END COVER-W001-3-600	2V000014336	Yes/No	300	Please see price bid
3	964652780000	METAL. END COVER-W001-3-300RV	2V000014336	Yes/No	1000	Please see price bid
4	964652790000	METAL. END COVER-W001-3-150GV/FV	2V000014336	Yes/No	2000	Please see price bid
5	964652800000	METAL. END COVER-W001-3-300GV	2V000014336	Yes/No	1000	Please see price bid
6	964652810000	METAL. END COVER-W001-4-600GV	2V000014336	Yes/No	50	Please see price bid
7	964652820000	METAL. END COVER-W001-3-300FV	2V000014336	Yes/No	400	Please see price bid
8	964652830000	METAL. END COVER-W001-4-150GV	2V000014336	Yes/No	800	Please see price bid
9	964652840000	METAL. END COVER-W001-4-300RV	2V000014336	Yes/No	400	Please see price bid
10	964652850000	METAL. END COVER-W001-4-150FV	2V000014336	Yes/No	200	Please see price bid
11	964652860000	METAL. END COVER-W001-4-150GV	2V000014336	Yes/No	600	Please see price bid
12	964652870000	METAL. END COVER-W001-6-600GV	2V000014336	Yes/No	400	Please see price bid
13	964652880000	METAL. END COVER-W001-6-150/300GV	2V000014336	Yes/No	800	Please see price bid
14	964652890000	METAL. END COVER-W001-6-150FV	2V000014336	Yes/No	300	Please see price bid
15	964652900000	METAL. END COVER-W001-6-300RV	2V000014336	Yes/No	1000	Please see price bid
16	964652910000	METAL. END COVER-W001-6-300FV	2V000014336	Yes/No	500	Please see price bid
17	964652920000	METAL. END COVER-W001-8-150GV	2V000014336	Yes/No	900	Please see price bid
18	964652930000	METAL. END COVER-W001-8-300GV/FV,8-60	2V000014336	Yes/No	700	Please see price bid
19	964652940000	METAL. END COVER-W001-8-150FV	2V000014336	Yes/No	400	Please see price bid
20	964652950000	METAL. END COVER-W001-8-300RV	2V000014336	Yes/No	150	Please see price bid
21	964652960000	METAL. END COVER-W001-10-150GV	2V000014336	Yes/No	100	Please see price bid
22	964652970000	METAL. END COVER-W001-10-600GV	2V000014336	Yes/No	100	Please see price bid
23	964652980000	METAL. END COVER-W001-10-300FV/GV	2V000014336	Yes/No	400	Please see price bid
24	964652990000	METAL. END COVER-W001-12-300FV	2V000014336	Yes/No	700	Please see price bid
25	964653000000	METAL. END COVER-W001-12-300GV	2V000014336	Yes/No	600	Please see price bid
26	964653010000	METAL. END COVER-W001-12-300GV	2V000014336	Yes/No	300	Please see price bid
27	964653020000	METAL. END COVER-W001-14-300GV	2V000014336	Yes/No	50	Please see price bid
28	964653030000	METAL. END COVER-W001-16-300GV/FV	2V000014336	Yes/No	200	Please see price bid
29	964653040000	METAL. END COVER-W001-18-150GV	2V000014336	Yes/No	200	Please see price bid
30	964653050000	METAL. END COVER-W001-20-150GV/FV	2V000014336	Yes/No	300	Please see price bid
31	964653060000	METAL. END COVER-W001-20-300GV	2V000014336	Yes/No	400	Please see price bid
32	964653070000	METAL. END COVER-W001-24-150GV	2V000014336	Yes/No	200	Please see price bid
33	964530010000	METAL. END COVER-G041	2V000015483	Yes/No	200	Please see price bid
34	964530020000	METAL. END COVER-W049	2V000015483	Yes/No	30	Please see price bid

Techno-Commercial/Unprice Bid Annexure to Enquiry No.1415-164 Dated 19.01.2015, Due date 10.02.2015

Enq Sl. No.	Code	Description of material	Drg No	Quoted (Yes/No)	Qty (Nos)	Unit Basic Price, Rs. per No.
35	964530030000	METAL. END COVER-W001	2V000015483	Yes/No	400	Please see price bid
36	964530040000	METAL. END COVER-G004	2V000015483	Yes/No	50	Please see price bid
37	964530050000	METAL. END COVER-L161	2V000015483	Yes/No	30	Please see price bid
38	964530060000	METAL. END COVER-G145	2V000015483	Yes/No	100	Please see price bid
39	964530070000	METAL. END COVER-W345	2V000015483	Yes/No	30	Please see price bid
40	964530080000	METAL. END COVER-L025	2V000015483	Yes/No	100	Please see price bid
41	964530090000	METAL. END COVER-G001	2V000015483	Yes/No	100	Please see price bid
42	964530100000	METAL. END COVER-L053	2V000015483	Yes/No	200	Please see price bid
43	964530110000	METAL. END COVER-W369	2V000015483	Yes/No	50	Please see price bid
44	964530120000	METAL. END COVER-W002	2V000015483	Yes/No	30	Please see price bid
45	964530130000	METAL. END COVER-W353	2V000015483	Yes/No	30	Please see price bid
46	964530140000	METAL. END COVER-W441	2V000015483	Yes/No	100	Please see price bid
47	964530150000	METAL. END COVER-W065	2V000015483	Yes/No	30	Please see price bid
48	964530160000	METAL. END COVER -W057-D193	2V000015483	Yes/No	30	Please see price bid
49	964530170000	METAL. END COVER-G002	2V000015483	Yes/No	50	Please see price bid
50	964530180000	METAL. END COVER-W113	2V000015483	Yes/No	30	Please see price bid
51	964530190000	METAL. END COVER-L002	2V000015483	Yes/No	30	Please see price bid
52	964530200000	METAL. END COVER-W003	2V000015483	Yes/No	50	Please see price bid
53	964530210000	METAL. END COVER-L177	2V000015483	Yes/No	30	Please see price bid
54	964530220000	METAL. END COVER-L129	2V000015483	Yes/No	30	Please see price bid
55	964530230000	METAL. END COVER-W061	2V000015483	Yes/No	30	Please see price bid
56	964530240000	METAL. END COVER-W005	2V000015483	Yes/No	30	Please see price bid
57	964530250000	METAL. END COVER-W117	2V000015483	Yes/No	50	Please see price bid
58	964530260000	METAL. END COVER-L121	2V000015483	Yes/No	30	Please see price bid
59	964530270000	METAL. END COVER-W465	2V000015483	Yes/No	30	Please see price bid
60	964530280000	METAL. END COVER-L029	2V000015483	Yes/No	30	Please see price bid
61	964530290000	METAL. END COVER-W006	2V000015483	Yes/No	30	Please see price bid
62	964530300000	METAL. END COVER-L081	2V000015483	Yes/No	30	Please see price bid
63	964530310000	METAL. END COVER-L113	2V000015483	Yes/No	30	Please see price bid
64	964530320000	METAL. END COVER-W069	2V000015483	Yes/No	30	Please see price bid
65	964530330000	METAL. END COVER-G137	2V000015483	Yes/No	100	Please see price bid
66	964530340000	METAL. END COVER-W457	2V000015483	Yes/No	100	Please see price bid
67	964530350000	METAL. END COVER-W073	2V000015483	Yes/No	30	Please see price bid
68	964530360000	METAL. END COVER-W515	2V000015483	Yes/No	30	Please see price bid
69	964530370000	METAL. END COVER-W417	2V000015483	Yes/No	30	Please see price bid
70	964531150000	METAL. END COVER-W077	2V000015483	Yes/No	30	Please see price bid
71	964531160000	METAL. END COVER-W505	2V000015483	Yes/No	30	Please see price bid
72	964531740000	METAL. END COVER-L033	2V000015483	Yes/No	30	Please see price bid
73	964531750000	METAL. END COVER-L169	2V000015483	Yes/No	30	Please see price bid
74	964531760000	METAL. END COVER-W393	2V000015483	Yes/No	300	Please see price bid
75	964531770000	METAL. END COVER-L089	2V000015483	Yes/No	30	Please see price bid

Techno-Commercial/Unprice Bid Annexure to Enquiry No.1415-164 Dated 19.01.2015, Due date 10.02.2015

Enq Sl. No.	Code	Description of material	Drg No	Quoted (Yes/No)	Qty (Nos)	Unit Basic Price, Rs. per No.
76	964533550000	METAL. END COVER-W752	2V000015483	Yes/No	50	Please see price bid
77	964533590000	METAL. END COVER-W021	2V000015483	Yes/No	1200	Please see price bid
78	964650090000	METTALIC ENDCOVER-K616	2V000015483	Yes/No	100	Please see price bid
79	964650110000	METAL.END COVER-N589	2V000015483	Yes/No	600	Please see price bid
80	964650100000	METAL.END COVER-N370	2V000015483	Yes/No	150	Please see price bid
81	964650120000	METAL.END COVER-N594	2V000015483	Yes/No	250	Please see price bid
82	964651370000	METAL. END COVER-3204	2V000015483	Yes/No	200	Please see price bid
83	964652090000	METAL. END COVER-P366	2V000015483	Yes/No	300	Please see price bid
84	964660030000	METALLIC END COVER	2V000015483	Yes/No	30	Please see price bid
85	964653650000	METAL. END COVER-NG24	2V000015483	Yes/No	1500	Please see price bid
86	964654100000	METAL. END COVER-3319	2V000015483	Yes/No	30	Please see price bid
87	964654140000	METAL. END COVER-P560	2V000015483	Yes/No	50	Please see price bid
88	964661000000	METAL. END COVER	2V000015483	Yes/No	30	Please see price bid
89	964661010000	METAL. END COVER	2V000015483	Yes/No	30	Please see price bid
90	964655050000	METAL. END COVER-F999	2V000015483	Yes/No	30	Please see price bid
91	964605530000	METAL END COVER 8/300-L915	3V000022267	Yes/No	30	Please see price bid
92	964605540000	METAL END COVER 12/150-L929	3V000022267	Yes/No	30	Please see price bid
93	964605550000	METAL END COVER 16/150-L943	3V000022267	Yes/No	30	Please see price bid
94	964605560000	METAL END COVER 24/150-L957	3V000022267	Yes/No	50	Please see price bid
95	964605570000	METAL END COVER 18/600-L820	3V000022267	Yes/No	50	Please see price bid
96	964605580000	METAL END COVER 6/300-L825	3V000022267	Yes/No	30	Please see price bid
97	964605590000	METAL END COVER 10/300-L841	3V000022267	Yes/No	30	Please see price bid
98	964605600000	METAL END COVER 12/300-L857	3V000022267	Yes/No	30	Please see price bid
99	964605610000	METAL END COVER 6/600-L873	3V000022267	Yes/No	30	Please see price bid
100	964605620000	METAL END COVER 14/600-L889	3V000022267	Yes/No	30	Please see price bid
101	964606420000	METAL END COVER 14/150-L893	3V000022267	Yes/No	30	Please see price bid
102	964606430000	METAL END COVER 18/150-L805	3V000022267	Yes/No	30	Please see price bid
103	964606520000	METAL END COVER 22/18-L890	3V000022267	Yes/No	30	Please see price bid
104	964606530000	METAL END COVER 16/18-L891	3V000022267	Yes/No	100	Please see price bid
105	964606540000	METAL END COVER 20/300-L725	3V000022267	Yes/No	30	Please see price bid
106	964606550000	METAL END COVER 28/26-L751	3V000022267	Yes/No	30	Please see price bid
107	964606560000	METAL END COVER 24/600-L752	3V000022267	Yes/No	30	Please see price bid
108	964606570000	METAL END COVER 16/300-L984	3V000022267	Yes/No	100	Please see price bid
109	964606580000	METAL END COVER 16/600-L783	3V000022267	Yes/No	30	Please see price bid
110	964606980000	METAL END COVER 32/600-L793	3V000022267	Yes/No	30	Please see price bid
111	964606990000	METAL END COVER 32/150-L789	3V000022267	Yes/No	30	Please see price bid
112	964607450000	METAL END COVER 10/600-L507	3V000022267	Yes/No	30	Please see price bid
113	964607460000	METAL END COVER 8X10x8 RED-L508	3V000022267	Yes/No	30	Please see price bid
114	964607930000	METALLIC END COVER 32"CRH-L794	3V000022267	Yes/No	30	Please see price bid
115	964608140000	METAL END COVER 16/300-L985	3V000022267	Yes/No	30	Please see price bid
116	964620310000	METALLIC END COVER 32"CRH-LA41	3V000022267	Yes/No	30	Please see price bid

Techno-Commercial/Unprice Bid Annexure to Enquiry No.1415-164 Dated 19.01.2015, Due date 10.02.2015						
Enq Sl. No.	Code	Description of material	Drg No	Quoted (Yes/No)	Qty (Nos)	Unit Basic Price, Rs. per No.
117	964536440000	METTALIC ENDCOVER-N590	3V000023461	Yes/No	50	Please see price bid
118	964536450000	METTALIC ENDCOVER-N593	3V000023461	Yes/No	100	Please see price bid
119	964536460000	METTALIC ENDCOVER-N595	3V000023461	Yes/No	100	Please see price bid
120	964535420000	METALIC END COVER-V137	3V000023461	Yes/No	30	Please see price bid
121	964535430000	METALIC END COVER-V329	3V000023461	Yes/No	30	Please see price bid
122	964535440000	METALIC END COVER-V465	3V000023461	Yes/No	30	Please see price bid
123	964536900000	METALIC END COVER-C520	3V000023461	Yes/No	30	Please see price bid
124	964536910000	METALIC END COVER-C524	3V000023461	Yes/No	30	Please see price bid
125	964536920000	METALIC END COVER-C526	3V000023461	Yes/No	30	Please see price bid
126	964650010000	METTALIC ENDCOVER-N826	3V000023461	Yes/No	300	Please see price bid
127	964535770000	METALIC END COVER	3V000023461	Yes/No	30	Please see price bid
128	964535890000	METALIC END COVER	3V000023461	Yes/No	30	Please see price bid
129	964535910000	METALIC END COVER	3V000023461	Yes/No	30	Please see price bid
130	964653630000	METAL. END COVER-3318	3V000023461	Yes/No	30	Please see price bid
131	964608200000	METAL END COVER 24/600-L752	3V000022633	Yes/No	30	Please see price bid
132	964620070000	METAL END COVER 24/600 -L753	3V000022633	Yes/No	30	Please see price bid
133	964620220000	METAL END COVER -L475 -ID584	3V000022633	Yes/No	30	Please see price bid
134	G96120080000	METTALIC END COVER-2-C300-RV-BW	Sketch	Yes/No	200	Please see price bid
135	842020136700	BOTTOM COVER ASS-20025700	22020100257/07	Yes/No	2000	Please see price bid
136	842020115800	GUARD ASSY-20003900	22020100039/14	Yes/No	2000	Please see price bid
Excise Duty rate (mention in % if applicable, mention as NIL if not applicable)						
Cess on ED rate (mention in % if applicable)						
CST (%) / VAT (%)						
Validity of offers (As per BHEL terms 90 days validity is required)						
The above prices are Firm, without any price escalation; are Rs. per piece; and are on FOR Goindwal Sahib basis.						
We accept all terms and conditions of the Enquiry No.1415-164 Dated 19.01.2015, Due date 10.02.2015						
Authorised signatory with seal						

Price Bid Annexure to Enquiry No.1415-164 Dated 19.01.2015, Due date 10.02.2015

Enq Sl. No.	Code	Description of material	Drg No	Quoted(Yes/No)	Qty (Nos)	Unit Basic Price, Rs. per No. (In figures)	Unit Basic Price, Rs. per No. (In Words)
1	964652760000	METAL. END COVER-W001	2V000014336	Yes/No	1000		
2	964652770000	METAL. END COVER-W001-3-600	2V000014336	Yes/No	300		
3	964652780000	METAL. END COVER-W001-3-300RV	2V000014336	Yes/No	1000		
4	964652790000	METAL. END COVER-W001-3-150GV/FV	2V000014336	Yes/No	2000		
5	964652800000	METAL. END COVER-W001-3-300GV	2V000014336	Yes/No	1000		
6	964652810000	METAL. END COVER-W001-4-600GV	2V000014336	Yes/No	50		
7	964652820000	METAL. END COVER-W001-3-300FV	2V000014336	Yes/No	400		
8	964652830000	METAL. END COVER-W001-4-150GV	2V000014336	Yes/No	800		
9	964652840000	METAL. END COVER-W001-4-300RV	2V000014336	Yes/No	400		
10	964652850000	METAL. END COVER-W001-4-150FV	2V000014336	Yes/No	200		
11	964652860000	METAL. END COVER-W001-4-150GV	2V000014336	Yes/No	600		
12	964652870000	METAL. END COVER-W001-6-600GV	2V000014336	Yes/No	400		
13	964652880000	METAL. END COVER-W001-6-150/300GV	2V000014336	Yes/No	800		
14	964652890000	METAL. END COVER-W001-6-150FV	2V000014336	Yes/No	300		
15	964652900000	METAL. END COVER-W001-6-300RV	2V000014336	Yes/No	1000		
16	964652910000	METAL. END COVER-W001-6-300FV	2V000014336	Yes/No	500		
17	964652920000	METAL. END COVER-W001-8-150GV	2V000014336	Yes/No	900		
18	964652930000	METAL. END COVER-W001-8-300GV/FV,8-60	2V000014336	Yes/No	700		
19	964652940000	METAL. END COVER-W001-8-150FV	2V000014336	Yes/No	400		
20	964652950000	METAL. END COVER-W001-8-300RV	2V000014336	Yes/No	150		
21	964652960000	METAL. END COVER-W001-10-150GV	2V000014336	Yes/No	100		
22	964652970000	METAL. END COVER-W001-10-600GV	2V000014336	Yes/No	100		
23	964652980000	METAL. END COVER-W001-10-300FV/GV	2V000014336	Yes/No	400		
24	964652990000	METAL. END COVER-W001-12-300FV	2V000014336	Yes/No	700		
25	964653000000	METAL. END COVER-W001-12-300GV	2V000014336	Yes/No	600		
26	964653010000	METAL. END COVER-W001-12-300GV	2V000014336	Yes/No	300		
27	964653020000	METAL. END COVER-W001-14-300GV	2V000014336	Yes/No	50		
28	964653030000	METAL. END COVER-W001-16-300GV/FV	2V000014336	Yes/No	200		
29	964653040000	METAL. END COVER-W001-18-150GV	2V000014336	Yes/No	200		
30	964653050000	METAL. END COVER-W001-20-150GV/FV	2V000014336	Yes/No	300		
31	964653060000	METAL. END COVER-W001-20-300GV	2V000014336	Yes/No	400		
32	964653070000	METAL. END COVER-W001-24-150GV	2V000014336	Yes/No	200		
33	964530010000	METAL. END COVER-G041	2V000015483	Yes/No	200		
34	964530020000	METAL. END COVER-W049	2V000015483	Yes/No	30		

Price Bid Annexure to Enquiry No.1415-164 Dated 19.01.2015, Due date 10.02.2015

Enq Sl. No.	Code	Description of material	Drg No	Quoted(Yes/No)	Qty (Nos)	Unit Basic Price, Rs. per No. (In figures)	Unit Basic Price, Rs. per No. (In Words)
35	964530030000	METAL. END COVER-W001	2V000015483	Yes/No	400		
36	964530040000	METAL. END COVER-G004	2V000015483	Yes/No	50		
37	964530050000	METAL. END COVER-L161	2V000015483	Yes/No	30		
38	964530060000	METAL. END COVER-G145	2V000015483	Yes/No	100		
39	964530070000	METAL. END COVER-W345	2V000015483	Yes/No	30		
40	964530080000	METAL. END COVER-L025	2V000015483	Yes/No	100		
41	964530090000	METAL. END COVER-G001	2V000015483	Yes/No	100		
42	964530100000	METAL. END COVER-L053	2V000015483	Yes/No	200		
43	964530110000	METAL. END COVER-W369	2V000015483	Yes/No	50		
44	964530120000	METAL. END COVER-W002	2V000015483	Yes/No	30		
45	964530130000	METAL. END COVER-W353	2V000015483	Yes/No	30		
46	964530140000	METAL. END COVER-W441	2V000015483	Yes/No	100		
47	964530150000	METAL. END COVER-W065	2V000015483	Yes/No	30		
48	964530160000	METAL. END COVER -W057-D193	2V000015483	Yes/No	30		
49	964530170000	METAL. END COVER-G002	2V000015483	Yes/No	50		
50	964530180000	METAL. END COVER-W113	2V000015483	Yes/No	30		
51	964530190000	METAL. END COVER-L002	2V000015483	Yes/No	30		
52	964530200000	METAL. END COVER-W003	2V000015483	Yes/No	50		
53	964530210000	METAL END COVER-L177	2V000015483	Yes/No	30		
54	964530220000	METAL. END COVER-L129	2V000015483	Yes/No	30		
55	964530230000	METAL. END COVER-W061	2V000015483	Yes/No	30		
56	964530240000	METAL. END COVER-W005	2V000015483	Yes/No	30		
57	964530250000	METAL. END COVER-W117	2V000015483	Yes/No	50		
58	964530260000	METAL. END COVER-L121	2V000015483	Yes/No	30		
59	964530270000	METAL. END COVER-W465	2V000015483	Yes/No	30		
60	964530280000	METAL. END COVER-L029	2V000015483	Yes/No	30		
61	964530290000	METAL. END COVER-W006	2V000015483	Yes/No	30		
62	964530300000	METAL. END COVER-L081	2V000015483	Yes/No	30		
63	964530310000	METAL. END COVER-L113	2V000015483	Yes/No	30		
64	964530320000	METAL. END COVER-W069	2V000015483	Yes/No	30		
65	964530330000	METAL. END COVER-G137	2V000015483	Yes/No	100		
66	964530340000	METAL. END COVER-W457	2V000015483	Yes/No	100		
67	964530350000	METAL. END COVER-W073	2V000015483	Yes/No	30		
68	964530360000	METAL. END COVER-W515	2V000015483	Yes/No	30		

Price Bid Annexure to Enquiry No.1415-164 Dated 19.01.2015, Due date 10.02.2015

Enq Sl. No.	Code	Description of material	Drg No	Quoted(Yes/No)	Qty (Nos)	Unit Basic Price, Rs. per No. (In figures)	Unit Basic Price, Rs. per No. (In Words)
69	964530370000	METAL. END COVER-W417	2V000015483	Yes/No	30		
70	964531150000	METAL. END COVER-W077	2V000015483	Yes/No	30		
71	964531160000	METAL. END COVER-W505	2V000015483	Yes/No	30		
72	964531740000	METAL.END COVER-L033	2V000015483	Yes/No	30		
73	964531750000	METAL.END COVER-L169	2V000015483	Yes/No	30		
74	964531760000	METAL.END COVER-W393	2V000015483	Yes/No	300		
75	964531770000	METAL.END COVER-L089	2V000015483	Yes/No	30		
76	964533550000	METAL. END COVER-W752	2V000015483	Yes/No	50		
77	964533590000	METAL. END COVER-W021	2V000015483	Yes/No	1200		
78	964650090000	METTALIC ENDCOVER-K616	2V000015483	Yes/No	100		
79	964650110000	METAL.END COVER-N589	2V000015483	Yes/No	600		
80	964650100000	METAL.END COVER-N370	2V000015483	Yes/No	150		
81	964650120000	METAL.END COVER-N594	2V000015483	Yes/No	250		
82	964651370000	METAL. END COVER-3204	2V000015483	Yes/No	200		
83	964652090000	METAL. END COVER-P366	2V000015483	Yes/No	300		
84	964660030000	METALLIC END COVER	2V000015483	Yes/No	30		
85	964653650000	METAL. END COVER-NG24	2V000015483	Yes/No	1500		
86	964654100000	METAL. END COVER-3319	2V000015483	Yes/No	30		
87	964654140000	METAL. END COVER-P560	2V000015483	Yes/No	50		
88	964661000000	METAL. END COVER	2V000015483	Yes/No	30		
89	964661010000	METAL. END COVER	2V000015483	Yes/No	30		
90	964655050000	METAL. END COVER-F999	2V000015483	Yes/No	30		
91	964605530000	METAL END COVER 8/300-L915	3V000022267	Yes/No	30		
92	964605540000	METAL END COVER 12/150-L929	3V000022267	Yes/No	30		
93	964605550000	METAL END COVER 16/150-L943	3V000022267	Yes/No	30		
94	964605560000	METAL END COVER 24/150-L957	3V000022267	Yes/No	50		
95	964605570000	METAL END COVER 18/600-L820	3V000022267	Yes/No	50		
96	964605580000	METAL END COVER 6/300-L825	3V000022267	Yes/No	30		
97	964605590000	METAL END COVER 10/300-L841	3V000022267	Yes/No	30		
98	964605600000	METAL END COVER 12/300-L857	3V000022267	Yes/No	30		
99	964605610000	METAL END COVER 6/600-L873	3V000022267	Yes/No	30		
100	964605620000	METAL END COVER 14/600-L889	3V000022267	Yes/No	30		
101	964606420000	METAL END COVER 14/150-L893	3V000022267	Yes/No	30		
102	964606430000	METAL END COVER 18/150-L805	3V000022267	Yes/No	30		

Price Bid Annexure to Enquiry No.1415-164 Dated 19.01.2015, Due date 10.02.2015

Enq Sl. No.	Code	Description of material	Drg No	Quoted(Yes/No)	Qty (Nos)	Unit Basic Price, Rs. per No. (In figures)	Unit Basic Price, Rs. per No. (In Words)
103	964606520000	METAL END COVER 22/18-L890	3V000022267	Yes/No	30		
104	964606530000	METAL END COVER 16/18-L891	3V000022267	Yes/No	100		
105	964606540000	METAL END COVER 20/300-L725	3V000022267	Yes/No	30		
106	964606550000	METAL END COVER 28/26-L751	3V000022267	Yes/No	30		
107	964606560000	METAL END COVER 24/600-L752	3V000022267	Yes/No	30		
108	964606570000	METAL END COVER 16/300-L984	3V000022267	Yes/No	100		
109	964606580000	METAL END COVER 16/600-L783	3V000022267	Yes/No	30		
110	964606980000	METAL END COVER 32/600-L793	3V000022267	Yes/No	30		
111	964606990000	METAL END COVER 32/150-L789	3V000022267	Yes/No	30		
112	964607450000	METAL END COVER 10/600-L507	3V000022267	Yes/No	30		
113	964607460000	METAL END COVER 8X10x8 RED-L508	3V000022267	Yes/No	30		
114	964607930000	METALLIC END COVER 32"CRH-L794	3V000022267	Yes/No	30		
115	964608140000	METAL END COVER 16/300-L985	3V000022267	Yes/No	30		
116	964620310000	METALLIC END COVER 32"CRH-LA41	3V000022267	Yes/No	30		
117	964536440000	METTALIC ENDCOVER-N590	3V000023461	Yes/No	50		
118	964536450000	METTALIC ENDCOVER-N593	3V000023461	Yes/No	100		
119	964536460000	METTALIC ENDCOVER-N595	3V000023461	Yes/No	100		
120	964535420000	METALIC END COVER-V137	3V000023461	Yes/No	30		
121	964535430000	METALIC END COVER-V329	3V000023461	Yes/No	30		
122	964535440000	METALIC END COVER-V465	3V000023461	Yes/No	30		
123	964536900000	METALIC END COVER-C520	3V000023461	Yes/No	30		
124	964536910000	METALIC END COVER-C524	3V000023461	Yes/No	30		
125	964536920000	METALIC END COVER-C526	3V000023461	Yes/No	30		
126	964650010000	METTALIC ENDCOVER-N826	3V000023461	Yes/No	300		
127	964535770000	METALIC END COVER	3V000023461	Yes/No	30		
128	964535890000	METALIC END COVER	3V000023461	Yes/No	30		
129	964535910000	METALIC END COVER	3V000023461	Yes/No	30		
130	964653630000	METAL. END COVER-3318	3V000023461	Yes/No	30		
131	964608200000	METAL END COVER 24/600-L752	3V000022633	Yes/No	30		
132	964620070000	METALEND COVER 24/600 -L753	3V000022633	Yes/No	30		
133	964620220000	METAL END COVER -L475 -ID584	3V000022633	Yes/No	30		
134	G96120080000	METTALIC END COVER-2-C300-RV-BW	Sketch	Yes/No	200		
135	842020136700	BOTTOM COVER ASS-20025700	22020100257/07	Yes/No	2000		
136	842020115800	GUARD ASSY-20003900	22020100039/14	Yes/No	2000		

Price Bid Annexure to Enquiry No.1415-164 Dated 19.01.2015, Due date 10.02.2015

Enq Sl. No.	Code	Description of material	Drg No	Quoted(Yes/No)	Qty (Nos)	Unit Basic Price, Rs. per No. (In figures)	Unit Basic Price, Rs. per No. (In Words)
-------------------	------	-------------------------	--------	----------------	-----------	---	---

Authorised signatory with seal