



BHARAT HEAVY ELECTRICALS LIMITED

HEEP HARIDWAR INDIA-PIN 249403

FAX NO: 0091 1334 226462

PHONE NO: 0091 1334 284593

Tender No.: L/6433/2015/1326D/1

Sub: BHEL-HEEP/OPEN-TENDER (TL)/2015

Dear Sir,

The Heavy Electricals Equipment Plant (HEEP) located in Haridwar, India is one of the major manufacturing plants of Bharat Heavy Electricals Ltd. The core business of HEEP includes design and manufacture of large steam and gas turbines, turbo generators and so on.

Sealed tenders with the Tender No. and opening date clearly super scribed on the cover are invited from the manufacturers (registered as well as unregistered) for the supply of the following items:-

S. No.	Tender No.	Description of Item	Qty	Delivery Schedule	Opening Date
1	L/6433/2015/1326D/1	TLMW62778790 SUPPLY AND SUCCESSFUL ESTABLISHMENT OF TOOLING PACKAGE CONSISTING OF SPECIAL HOLDER & GROOVING TOOLS FOR ROUGH AND FINISH MACHINING OF DEEP GROOVE IN IP INNER CASING OF STEAM TURBINE ON CNC VERTICAL BORER AS PER ANNEXURE-1	1 SET	30.10.2015	23.09.2015

All items in the set shall be procured from same source due to compatibility reason.

Payment shall be made as per point no. 11.0 & 12.0 of the annexure – 1 as per tender document.

The tender documents can be down loaded from our web site www.bhel.com or www.bhelhwr.co.in or www.tenders.gov.in submitted with requisite EMD and tender fee.

The date for opening of tender shall be 23.09.2015. Tenders will be received in tender box kept at Main ADM building, HEEP – BHEL Ranipur , Haridwar – 249403, Uttarakhand (INDIA) up to 1.45 P.M. on 23.09.2015 and opened on the same day at 2.00 P.M. in the Tender Room. **Please note that tender received after due time & date (1.45PM on 23.09.2015) will not be REPEAT will not be opened.** BHEL will not be responsible for any type of delay due to postal / courier etc. and it shall be the responsibility of vendor to submit offer in time in tender box.

Intending vendors must remit the **tender fee of Rs. 2,000/- (Rupees Two Thousand)** along with the requisite **EMD Rs. 60,000/- (Rupees Sixty Thousand)** against each tender in the form of bank draft while submitting the tender documents [PLEASE SUBMIT SEPARATE DRAFTS FOR EMD AND TENDER FEE]. **Drafts shall be drawn in favour of “BHEL, HARIDWAR” and envelopes superscribed with bold letters “EMD & TENDER FEE”.**

As per notification reference no. NSIC/HO/GP/15(4)/ 2013-14 dated 07.07.2013 Micro & Small Enterprises (MSEs) is not required to submit Tender fees & EMD. A certificate issued from competent authority shall be submitted in support of Micro & Small Enterprises (MSEs). BHEL will not be responsible for any type of postal delay / incomplete information from vendor.

BHEL-HEEP registered vendors in PMD TL013 are exempted from submission of EMD in case of open tender of related PMD items. However, Tender Fee has to be submitted.

Specifications, Drawing & instructions of the above items are available on our above website with links provided for all Specifications, Drawings & Annexure (At the end of this document).

Amendments/Corrigendum, if any, will be hosted on our web site only. Other terms and conditions will be as per tender documents.

Please submit your offer for the above requirement subject to our terms and conditions.

The tender document must comprise of four envelopes :

- ❖ Envelope I : Tender fee & EMD or NSIC Certificate for exemption of tender fee & EMD.
- ❖ Envelope II : Supplier Registration Form (Annex. III for Foreign vendors and Annex. II for Indian vendors), Non Disclosure Agreement & Prequalifying conditions (Annexure –A).
- ❖ Envelope III : Techno-Commercial Bid.
- ❖ Envelope IV : Price Bid

BIDS shall be opened at 2.00 PM on the due date in the presence of authorized representative of the bidders who may like to be present. The authorized representative should bring authority letter from their parent company (Manufacturer) for attending the bid opening.

KINDLY READ “INSTRUCTIONS TO BIDDERS.” QUOTATION NOT IN ACCORDANCE WITH THE INSTRUCTIONS ARE LIABLE TO BE DISQUALIFIED AND IGNORED.

INSTRUCTIONS TO BIDDERS FOR OPEN TENDER

DEFINITION

Registered Vendors - Are those who are registered with BHEL, Haridwar for Megawatt rating/ Size/ Weight of tendered items in respective material grade or machining of such items.

Un-registered Vendors - Are those who are not registered with BHEL, Haridwar for Megawatt rating/ Size/ Weight of tendered items in respective material grade or machining of such items.

ESSENTIAL INSTRUCTIONS

* Un-registered vendors may be approved by BHEL, if found suitable, on the basis of data furnished by them in Supplier Registration Form (SRF) for Foreign Vendors or Indigenous Vendors (as applicable).

* BHEL team may visit the vendor (s) works for verification of capability and capacity claimed in tender documents/offer (s).

* The tenders shall be submitted in three parts in separate sub-envelopes clearly super scribing type of bid, tender no., due date and the name of vendor with full contact details.

❖ **Part I** – Tender fee & EMD or NSIC certificate for exemption of tender fee & EMD, Supplier Registration Form (Annexure – 2 or 3), Non Disclosure Agreement & Prequalifying conditions.

❖ **Part II** – Techno- Commercial Bid.

❖ **Part III** – Price Bid.

All the sub-envelopes to be put in a single covering envelope indicating tender no., due date and the name of vendor with full contact details. Offer should be complete in all respect (i.e. Part-I, Part-II & Part-III).

* Please quote your rates with both the options (a) C&F Landing port & (b) FOB dispatching port. In case of FOB dispatching port, BHEL will add sea freight, insurance and administrative charges for comparison purpose. The offers of vendors not quoting FOB prices in their offers submitted through tender room shall not be considered and will stand rejected outrightly (except high sea sales case).

* Please quote your rates in your currency or Indian Rupees.

* Indian Agents commission if payable shall be converted to Indian Rupees at TT buying rates of exchange ruling on tender opening date which shall not be subjected to any further exchange rate variation.

* The vendor must indicate the name of port of loading in their offer.

* While submitting your bids please clearly indicate:

(a) Expected Weight of goods (lots wise) .

(b) The size of packed goods.

(c) Whether the goods can be despatched in containers ?

* As per the Indian Law, all consignments being imported into India by air/sea require a phytosanitary certificate from the country of origin-if articles have been packed with packaging materials. This is mandatory.

- Packaging material means any kind of material of plant origin used for packing which include hay, straw wood shavings, wood chips, saw dust, wood waste, wooden pallets, dunnage mats, wooden packages, coir pith, peat or sphagnum moss etc.

- Please confirm in your offer/despatch documents that the required phytosanitary certificate will be submitted.

* The Trans-shipment condition in BHEL purchase orders / Letter of Credit will be governed by Uniform Customs and Practices for Documentary Credits, UCP 500 of International Standard Bank Procedures issued by the International Chamber of Commerce (ICC). Please refer to our web site www.bhelhwr.co.in under the heading " TRANS-SHIPMENT".

* Specifically confirm your agreement to air freight the material at your cost in case the delivery is delayed beyond 4 weeks. It is in addition to the penalty for delayed delivery as per the printed clause overleaf.

* The offer should be accompanied with relevant copies of catalogues, drawings or specification. If these documents are not furnished the offer is liable to be rejected.

* For evaluation, exchange rates (TT selling rates of SBI) as on scheduled date of tender opening (part 1 bid in case of 2 part bid) shall be considered.

* BHEL will deal directly with the manufacturers and no correspondence with the agents will be entertained. The agents will not be permitted to visit/ interact with BHEL on behalf of their principals. Subsequently also no correspondence of any type will be made with any agent. All individuals/ companies representing/ Advisor/retainer ship basis or claimed to be part time employee for many OEMs/claiming to be channel/business partner for BHEL work/stockist not registered specifically etc are Agents.

- * The bidders (original registered suppliers) will have to submit the ink signed offer/bid in original directly to BHEL. In case the bid is submitted by FAX/email, the bidders shall simultaneously ensure submission of ink signed original bid to BHEL also in the manner prescribed in this tender.
- * However, the suppliers or their authorised representatives may be allowed to attend tender opening if duly authorised by their principals, through a specific letter for a particular enquiry, for price bid opening on that particular day. General authorization letter is not acceptable.
- * The hard copy of this enquiry is being sent through post.
- * As per directives of CENTRAL VIGILANCE COMMISSION, GOVERNMENT OF INDIA, One Agent can not represent two or more suppliers or quote on their behalf in a particular tender. If so found at any stage, BHEL-Hardwar is likely to cancel Enquiries/P.O.s to such suppliers. Further such Indian Agents are likely to be de-listed (Black listed for business from BHEL).
- * Vendor should quote price and delivery details as per commercial terms & conditions enclosed.
- * BHEL may load maximum penalty under Late Delivery Clause, to the extent the same is not agreed by the vendor, for the purpose of comparative statement. Where deliveries quoted by Vendors are not suiting, BHEL may also ignore the offer of the vendor.
- * Delivery schedule is as per our requirement. However vendor to quote best possible lead time from the date of placement of purchase order. Delivery is not sacrosanct. Offers of those vendors may not be considered if it is not found suitable to BHEL requirement.
- * RISK PURCHASE: In case of delays in supplies / defective supplies or non- fulfillment of any other terms and conditions given in Purchase Order the purchaser may cancel the Purchase Order in full or part thereof, and may also make the purchase of such material from elsewhere / alternative source at the risk and cost of the supplier. Vendors do not agree to the above RISK PURCHASE CLAUSE and in eventuality of RISK PURCHASE, may be banned for business with BHEL.
- * Loading on prices-In case of deviation in payment terms from standard terms & conditions, the loading pattern for comparison of price bids is mentioned below:
 - 1.25% per month for the amount exceeding 90% of the contract value. The period of loading shall be 1 month for indigenous items and 2 months for imported items. The loading will be done for each case more than Rs. 1 lac & is for comparison purpose only to determine L1 status.
- * Any document if identified as "AWAITED" against any of the items above, has to be submitted by the vendor in 4 sets alongwith their offer, for one-time approval by BHEL. Each document must be identified with a unique document no and its revision no.
- * All bank guarantees for Security Deposit as well as Performance Bank Guarantee should be from one of the BHEL consortium banks and the bank guarantee should be in the proforma as prescribed by BHEL. The proforma of bank guarantee and the list of consortium banks is displayed at BHEL website www.bhelhwr.co.in . However, in case the bank guarantee is not from BHEL consortium banks, then the vendor has to get the bank guarantee confirmed from one of the BHEL consortium banks and the bank charges are to be borne by the bidder. If any vendor does not accept this condition, their offer is likely to be ignored.
- *BHEL reserves rights to place order for tendered quantity on more than one vendor.
- * In case you are not quoting, please send your regret letter positively for our reference.
- * Intimate your email address or changes, if any, by email to asanyal@bhelhwr.co.in giving your Vendor Code.
- * The vendor shall have to pay 5% incidental charges while taking back supplied material if it is found rejected on receipt. The rejected material shall be sent back only after receipt of replacement.
- * The above terms and conditions supercede the same or similar terms and conditions, if appearing elsewhere in the enquiry or PO.
- * Following information is available on Busiess-to-Business Portal on website www.bhelhwr.co.in .: 1 Tender Submission, 2 Comparative Statement of Rates, 3 Status of tender enquiries, 4 Negotiations, 5 Status of purchase orders, 6 Pink Memos, 7 Rejection 8 Payment Status and 9 Vendor Registration. The user ID & password can be obtained from website itself.
- * Please resolve your rejections and unexecuted overdue purchahse orders immedaitely which are posted at website.
- * Please confirm that prices quoted are not more than the prices quoted any other BHEL unit.
- * Where ever national/international(N/IN) standards are referred, the latest N/IN standard & are to be followed. Mention year & date of standard revision that shall be followed for the supply.
- * Kindly quote your prices in figures and words both. Incase of any discrepancy in value, the prices quoted in words shall be considered for evaluation and establishing L1 status
- * TENDERS RECEIVED AFTER THE SPECIFIED TIME OF THEIR 'SUBMISSION' WILL BE TREATED AS LATE TENDERS AND SHALL NOT BE CONSIDERD UNDER ANY CIRUMSTANCES

* The offers of the bidders who are on the banned list as also the offers of the bidders, who engage the services of the banned firms, shall be rejected. The list of banned firms is available on web site www.bhel.com
* EMD given by all unsuccessful Tenderers shall be refunded on acceptance of award / LOI/PO by successful Tenderer. The EMD of successful bidder shall be returned after submission of Contract Execution Bank Guarantee (CEBG).

* MSE Suppliers can avail the intended benefits only if they submit along with the offer, attested copies of either EM II certificate having deemed validity (five years from the date of issue of acknowledgement in EM II) or valid NSIC certificate or EM II certificate along with attested copy of a CA certificate (Format enclosed at annexure-1 where deemed validity of EM II certificate of five years has expired) applicable for the relevant financial year (latest audited). Date to be reckoned for determining the deemed validity will be the date of bid opening (Part 1 in case of two part bid). Non submission of such documents will lead to consideration of their bid at par with other bidders. No benefit shall be applicable for this enquiry if any deficiency in the above required documents is found or the requisite documents are not submitted before price bid opening. If the tender is to be submitted through e-procurement portal, then the above required documents are to be uploaded on the portal. Documents should be notarized or attested by a Gazette officer.

* Any new supplier will be eligible for registration with BHEL as MSE supplier provided at least any one of the following documents are submitted along with application for registration :-

a. Valid NSIC Certificate or

b. Entrepreneurs Memorandum part II (EM II) certificate (valid based on deemed validity of 5 years) or

c. EM II certificate along with attested copy of CA Certificate (as per prescribed format at annexure 1) applicable for the relevant financial year (latest audited), where the deemed validity of EM II is over. However, credentials of all MSE supplier will be verified before advancing the intended benefits.

* MSE vendors claiming SC/ST status will have to submit SC/ST certificate of the Proprietor from competent authority. Attested (notarized or attested by Gazetted officer) copy to be submitted along with the offer.

* In case techno-commercial accepted vendors include MSE source and their prices (based on landed cost to BHEL) are within the price band of 15% w.r.t. L-1 vendor, then BHEL can offer 20% of quantity of respective item (rounded off to nearest number) to MSE vendors at L-1 price and in case, more than one MSE vendor is in 15 % band and the same is accepted by more than one MSE vendors then 20% quantities of respective items will be considered for ordering on proportionate basis amongst MSE vendors.

* While distributing the 20% quantity amongst MSE vendors the decimal points in quantity shall be ignored for all the vendors except the L-1 amongst MSE vendors. Balance quantity after allocating the quantity to other MSE vendors ignoring the quantities in decimal , shall be given to L-1 (amongst MSE) vendor. However if there are more than one MSE vendor at the same price level than preference for additional quantities due to ignoring off the decimal (as mentioned above) shall be given to the vendor offering favorable terms to BHEL and if the conditions offered are also same then preference will be given to the vendor having high SPR rating.

* In case there are more than one MSE vendors (with different landed cost to BHEL) within 15% price band of lowest bidder and quantity to be offered is 1 no. only, then preference shall be given to the MSE vendor with lowest landed cost .

* In case there are more than one MSE vendors (with same landed cost to BHEL) within 15% price band of lowest bidder and quantity to be offered is 1 no. only, then preference shall be given first, based on the favorable terms in the bid and in case terms are also same, the vendor with high SPR rating shall be given preference.

* If L1 vendor is MSE vendor, entire quantity will be given to such MSE vendor only.

* **Splitting to MSE vendor in this case is not applicable.**

* **Foreign and Indigenous bidders against open tender will necessarily have to obtain class – III DSCs.**

Procedure for application is available on www.bhel.com.

* After placement of P.O against the tender, vendor should submit their invoices against goods and services immediately after supply of goods & services but not later than 30 days from the invoice date. In case of delay, consequential losses like loss of input credit and non-availability of concessional forms etc, shall be to the vendor account.

* **SETTLEMENT OF DISPUTES**

Indigenous Vendors: In all cases of dispute the matter shall be referred for arbitration to any arbitrator to be appointed by the Executive Director or any officer who is the administrative head of Bharat Heavy Electricals Ltd., at Haridwar. The venue of arbitration shall invariably be Ranipur, Haridwar. The award of the arbitrator shall be final and binding on both the parties. The arbitrator shall have the power to extend, from time to time, the time for making his award with the consent of the parties.

Foreign Vendors: In the event of any dispute or difference arising between the parties to this contract

regarding execution of same or their respective rights and liabilities there under, the same shall except as otherwise expressly provided therein, be referred to the arbitration of the two arbitrators, one to be appointed by each party; or in the case of the said arbitrators not agreeing then an umpire to be appointed by the two arbitrators in writing before entering on that reference and provisions of the Indian Arbitration Act ,1940 or any statutory notification, or re-enactment therefore and rules framed there under from time to time shall apply to such arbitration . If the two arbitrators do not agree on the appointment of umpire, the nomination of the umpire shall be done by the International Chamber of Commerce, Paris(France).The decision of arbitrators, or in case of their not agreeing, that of the said umpire shall be binding both on seller and purchaser. The venue of the arbitration invariably be New Delhi.

* JURISDICTION - All question, dispute or differences arising under, out of or in connection with the purchase order shall be subject to the exclusive jurisdiction of Haridwar courts.

* OVER RIDING CLAUSE - All stipulations made in any correspondence other than those exchanged in regards to "Instruction" in our tender documents / enquiry for submission of your offer, if at all shall be void to the extent they are repugnant to the conditions contained herein above and in the purchase order.

* FINALITY OF MANAGEMENT DECISION - At all places in the preceding clauses BHEL Management's decision shall be final.

Supply and successful establishment of Tooling package consisting of Special Holder and Grooving Tools for rough and finish machining of deep groove in IP Inner Casing of Steam Turbine on CNC Vertical Borer as per details given below :

Pre-Qualifying Conditions for Qualification of Participating Vendor :

- a) Only those vendors to quote who are Original tool manufacturer or authorized dealer/distributor of Original tool manufacturer. Authorization certificate from Original tool manufacturer to be furnished by the vendor with the offer.
- b) Vendor should have supplied grooving tool with Capto-C8(PSC-80) / KM-80 / HSK-80/100 or equivalent modular type quick change tooling system with coated carbide grooving inserts of width 8mm or more. In support of it, copies of relevant pages of product catalogue of Original tool manufacture or document verifying the supply is required to be submitted.

The following information is to be submitted by the participating vendor about the companies where referred tool have been supplied. This is required from all the vendors for qualification of their offer.

- 1) Name and address of the customer / company where referred tool have been supplied.
- 2) Name, designation, phone no. & email address of the contact person of the customer/company.
- 3) Month & Year of tool supply
- 4) Basic details of supplied tools like width of grooving insert, type of modular quick change tooling system, grooving depth.
- 5) The participating vendor should confirm satisfactory performance of tool supplied to referred customer/company.

BHEL reserves the right to verify the information provided by vendor. In case the information provided by vendor is found to be false/ incorrect, the offer shall be rejected.



Supply and successful establishment of Tooling package consisting of Special Holder and Grooving Tools for rough and finish machining of deep groove in IP Inner Casing of Steam Turbine on CNC Vertical Borer as per details given below :

- 1.0 Special Holder having provision for holding tools with Capto C8 (Polygonal Seat Cone – PSC80) / TS80 (KM80) / HSK 100 coupling (or higher size of these couplings) and matching grooving tools with dampening/ built in anti-vibration arrangement, are required for rough & finish machining of deep groove of width 20mm or 25mm and grooving depth of 200mm in IP Inner Casing on a CNC Vertical Borer. The special holder shall be clamped in square pocket (40*40mm) of conventional holder mounted on Ram of the machine. The schematic drawing of a Deep Groove in IP Inner Casing is shown below in Figure-1:

Figure-1 (Drawing of IP Inner Casing - Deep Groove)

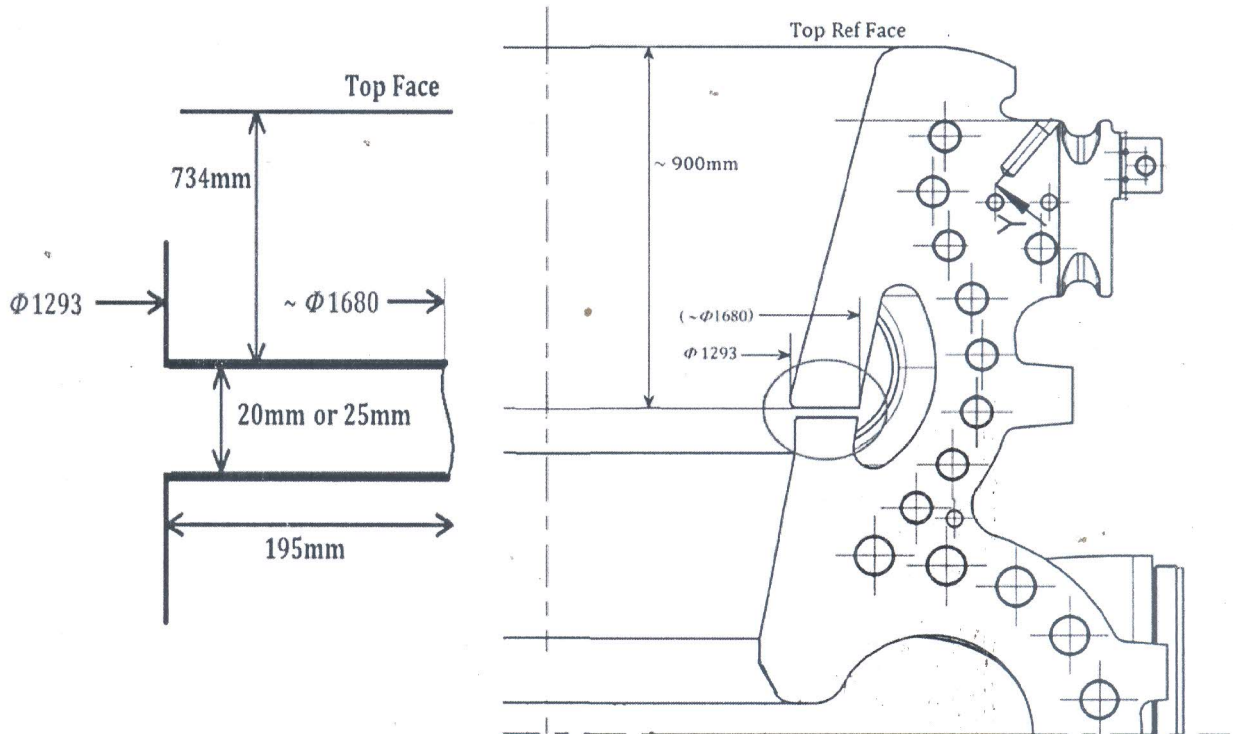

- 2.0 The Special holder having provision for holding tools with Capto C8 (Polygonal Seat Cone – PSC80) / TS80(KM80) / HSK100 coupling (or higher size of these couplings) and Grooving Tools shall be similar to schematic diagram shown below in figure 2.0, 2.1 & 2.2.

Figure-2.0 (Special Holder)

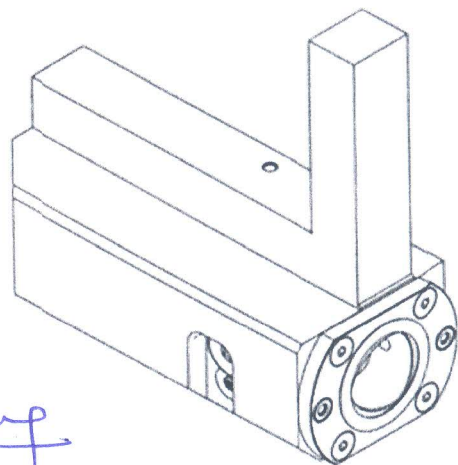

Taper

c15

2.1 : Schematic Details of Special Holder { Capto C8 (Polygonal Seat Cone - PSC80 / TS80 (KM80) / HSK100 } – **Figure 2.1**.
40*40mm shank (upper part) should be integral with lower part of special Holder (part having coupling). No welding or clamping with screw of upper part with lower part is allowed.

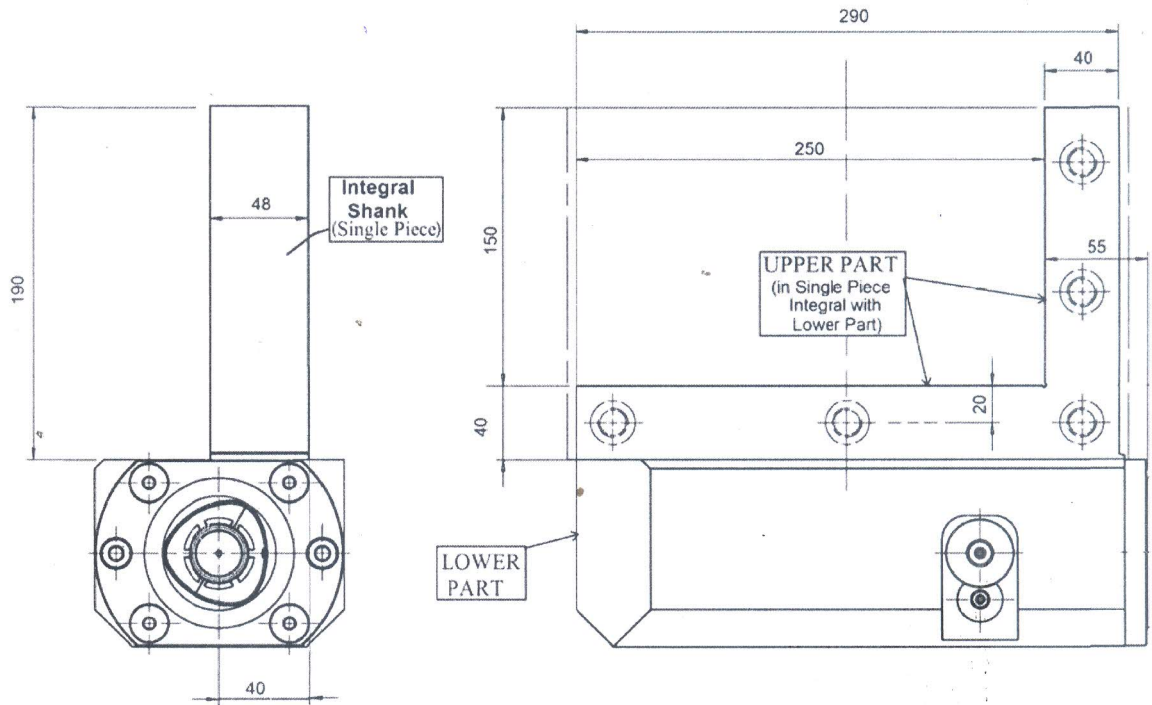

2.2 : Rough and Finish Grooving Tool (single integral piece) having **dampening/ built in anti-vibration arrangement**, matching with Holder/adaptor at 2.1 with working Grooving depth 'L' = 150mm and 200mm – **Figure 2.2**. No conversion or intermediary piece between Tool and special holder is allowed.

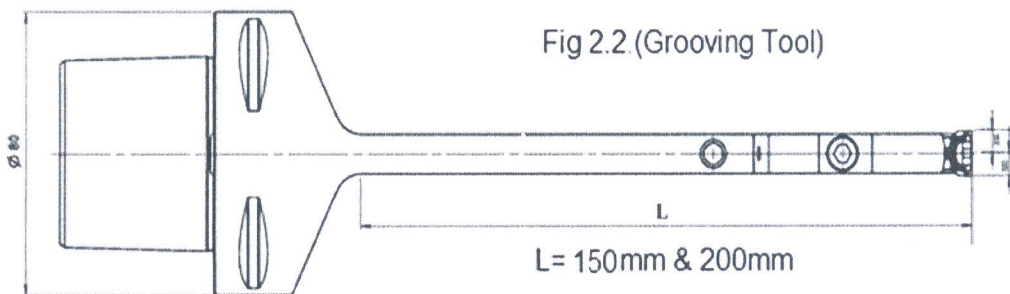
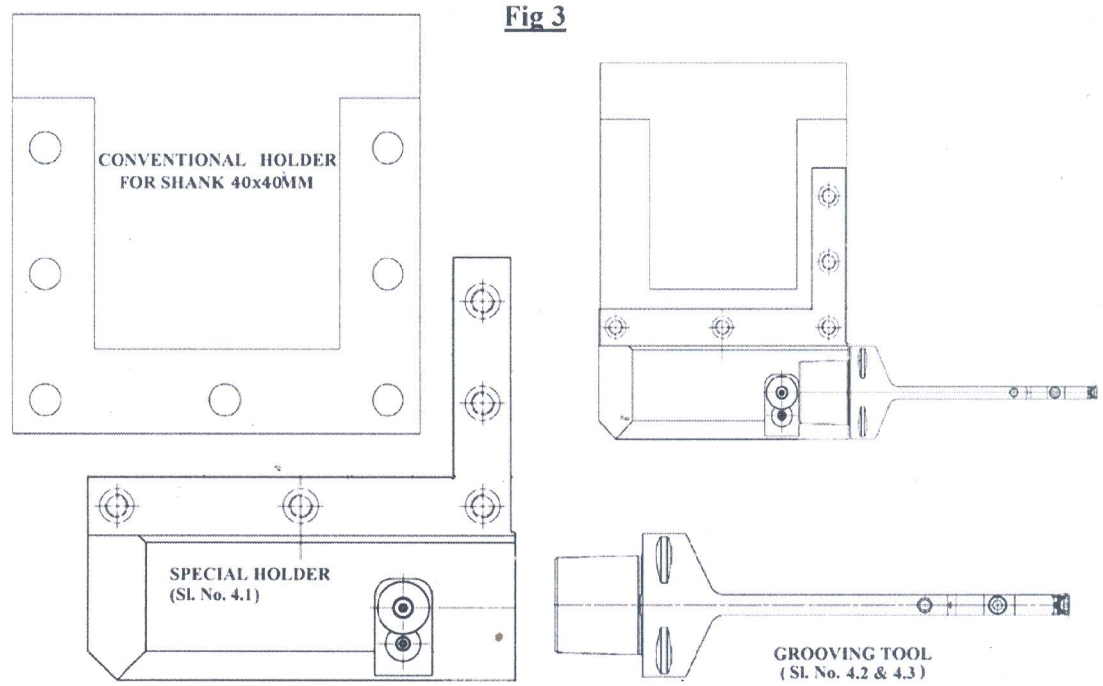

Fig 2.2 (Grooving Tool)

Deep

3.0 Clamping of Special holder in square pocket of conventional holder mounted on Ram is shown in Fig 3.



4.0 The tooling package supply shall be in two lots i.e. Lot-1 and Lot-2 having following items:

S.No.	Item Name	Quantity (in numbers)	
		Lot-1	Lot-2
4.1	Special Holder– Sl. No. 2.1	1	3
4.2	Grooving tool with grooving depth 'L'= 150mm – (Ref. Sl. No. 2.2)	1	3
4.3	Grooving tool with grooving depth 'L'= 200mm – (Ref. Sl. No. 2.2)	1	3
4.4	Total Inserts (equal distribution among each type of inserts - (Ref Sl. No. 5.0)	50	200
4.5	Spares (shims, screws, cartridges, key etc.)	4 (of each type)	6 (of each type)
4.6	Torque Wrench for Special Holder	1	2

5.0 Same or different type of inserts can be offered for both type of grooving tools at Sl.No. 4.2 & 4.3 above. Total specified quantity (against 4.4) shall be equally distributed among each type of offered inserts.

6.0 Width of grooving inserts should be between 10mm to 15mm. Insert design shall be as per recommendation & design of vendor. The insert geometry & grade should be suitable for smooth chip flow and at high cutting parameters & chip breaking.

[Handwritten Signature]

- 7.0 All items i.e. Special Holder, tool holders, inserts, consumables/spares etc. of all types shall be purchased from a same vendor for compatibility considerations. L1 shall be decided on price of total package i.e. 4.1, 4.2, 4.3, 4.4, 4.5 & 4.6 of Sl. No. 4 above considering total quantity of both the Lots (Lot-1 & Lot-2).
- 8.0 The offer should be complete having list & quantity of each item offered with item wise price, technical details, drawings of special items & catalogue pages of standard items etc. for clear understanding of the offer. In case, vendor requires any clarification, they may discuss with BHEL prior to submission of their offer to avoid any gaps at later stage.
- 9.0 The detail of Material properties of component (**I.P. Inner Casing**) is as follows :
Steel Casting with Identification **Gx12CrMoVNbN 9-1**
- **Chemical Composition** (in weight %) :
C (0.11-0.14), Si (0.2-0.5), Mn (0.4-0.8), P (≤ 0.02), S (≤ 0.01), Cr (8.0-9.5), Mo (0.9-1.05), V (0.18-0.25), Ni (≤ 0.4), Al (≤ 0.02), N (0.04-0.06).
 - **Mechanical Properties:** 0.2%PS ≥ 500 N/mm², UTS : 630-750 N/mm², El (l=5d) : $\geq 16\%$, Ra : ≥ 40 %, Impact : ≥ 35 J.
Hardening temp shall be between 1040 & 1070 deg C & tempering temp between 730 & 750 deg C.

10.0 Machining Condition and Acceptance criteria of Tooling Package by BHEL :

- 10.1 Acceptance by BHEL for supplied tools in LOT-1 (as per Sl. No. 4.3) shall be on successful machining by vendor at BHEL, Haridwar on a suitable component provided by BHEL on existing CNC Vertical Borer. Programing help with, if needed, shall be provided by BHEL. The machining shall be carried out at BHEL, Haridwar at mutually agreed schedule as per availability of component & machine and shall be considered successful as per criteria mentioned below at point no. 10.2, 10.3 (a, b, & c) & 10.4
- 10.2 Successful rough & finish machining of deep groove of width 20mm or 25mm (complete grooving depth of 200mm) on IP Inner Casing with material properties as per point no. 9 using supplies of Lot-1 and meeting drawing accuracy requirements.
- 10.3 Machining condition and Cutting Parameters:
- a) Rough Grooving up to initial depth of 140mm (maximum) will be done first with tool at Sl. No. 4.2 (Grooving tool with grooving depth 'L'=150mm). Tool and its insert should be capable of taking grooving cut with Feed F=0.07mm/rev or more and Cutting Speed Vc=40m/min or more for first plunge (with both points of tool engaged for cutting) and F=0.1mm/rev or more and Vc=50m/min or more for remaining cuts (with only one point of tool engaged for cutting). Full depth (upto 140mm) should be machined in 5 or less grooving cuts along depth with maximum 2 nos. of inserts.
 - b) Rough Grooving of remaining depth (from L=140mm to L~200mm) will be done with second tool at Sl. No. 4.3 (Grooving tool with grooving depth 'L'=200mm). Tool and its insert should be capable of taking grooving cut with Feed F=0.05mm/rev or more and Cutting Speed Vc=35m/min or more for first plunge

[Handwritten Signature]

012

(with both points of tool engaged for cutting) and $F=0.08\text{mm/rev}$ or more and $V_c=40\text{m/min}$ or more for remaining cuts (with only one point of tool engaged for cutting). Remaining Full depth (from 140mm upto 200mm) should be machined in 4 or less grooving cuts along depth with maximum 2 nos. of inserts.

c) Finishing of Groove i.e. finishing of groove width 20mm or 25mm will be done with tool at Sl. No. 4.3 (Grooving tool with grooving depth 'L'=200mm) with achievement of surface finish Ra 3.2 microns on side surfaces with single insert.

10.4 Deep groove shall be machined using supplied holder, tools, inserts etc. in Lot-1(as per Sl. No. 3.0). In case of any replacement/addition of any item, if so required by vendor for successful establishment of required machining, the same shall be done by vendor without any financial implications to BHEL.

11.0 The Payment for Lot-1 supplies shall be done after acceptance of the supplied tools in Lot-1 as mentioned above at point 10.0.

12.0 Supply of Lot-2 shall be subject to successful establishment of Lot-1 supplies and it's acceptance by BHEL as per point no. 10.0. Further, LOT-2 supply shall consist of items, which has been successfully established in LOT-1 considering Sl. No. 10.4.

13.0 Other conditions :

13.1 During implementation, if the tools offered by L1 vendor could not be established in one go then they may be given one additional chance to improve upon and establish the machining as per requirement through change of adaptor/tool/insert grade/process. In case of failure even in additional chance, all items supplied in LOT-1 shall be declared as rejected. There shall not be any LOT-2 supply for the tooling package.

13.2 In case of damage to any item other than consumables during successful establishment of required machining due to wrong machining strategy, wrong tool selection or cutting parameters, supply of improper tool or it's adaptor, improper fitting of tools in adaptors etc., the same shall be replaced by the vendor without any financial implications to BHEL.

13.3 The vendor will have to keep extra consumables of each type ready with them for supplying at short notice, if required, for complete machining as per tender scope to avoid any holdup for project completion.

13.4 Machining shall be carried out on one of the following CNC Vertical Borers having major specifications as below:

M/c #1

Make : Pietro Carnaghi, Italy
Table Dia: 6.5M
Table RPM: 0.2-50rpm
Power of main drive: 150kw
Max. permissible cutting force: 100KN
Cross-section of Ram: 500x500mm

M/c #2

Make : Wadrich Coburg, Germany
Table Dia: 7.5M
Table RPM: 0.1-50rpm
Power of main drive: 200kw
Max. permissible cutting force: 100KN
Cross-section of Ram: 450x450mm

Coolant (both M/c #1 & #2) : External Flood Coolant available using water mixed emulsion

- 13.5** Similar tooling system using special holder (clamping unit Capto C8, drawing no. 346_830111C967_D having internal coolant facility) and grooving tools with anti-vibration dampening arrangement, supplied by M/s Sandvik, is being used successfully on CNC Vertical Borer machine (1-032) in NTS at BHEL, Hardwar (M/c #2 specified at Sl. No.13.4). In case, M/s Sandvik participates and gets technically qualified and accepted wrt specified tender conditions with tools, similar as in use (Sandvik drg. No. 346_360211_N869 & 346_360212_N41 having internal coolant facility) with same grooving insert (sandvik code N123RI-1500-0008 GM 4225, W=15mm and N123R1-1270 0008 GM 4225, W=12.7mm), M/s Sandvik shall be exempted from trial machining (as specified at Sl. No. 10.0 of acceptance criteria).

._*._*._



	ANNEXURE 4	Document No.	AA:MM:SR:01
	GUIDELINES TO FOREIGN SUPPLIERS FOR FILLING UP SUPPLIER REGISTRATION FORM	Revision No.	01
		Page No.	I of II

1. Prospective Suppliers may also visit our web site www.bhel.com (link Supplier Registration -> New Supplier Required) to know more about the requirement of new suppliers for various items in our units.
2. Registration Form no. SRF(F)01 may be obtained from BHEL website www.bhel.com.
3. Application for registration, with a covering letter detailing where your products can find application (if possible) in BHEL unit(s), should be sent to:

Supplier Development Cell
Unit Name:
 Bharat Heavy Electricals Ltd.
City:
 India

4. In case registration is being sought in multiple units of BHEL, please send the separate application to each unit.
5. Any clarification with respect to procedure for registration may be obtained from the Supplier Development Cell of respective BHEL unit.
6. All columns are to be filled up properly in the space provided for. Wherever it is not applicable, mention it as "Not Applicable". The form is to be signed by the authorised signatory and submitted in original.
7. Please attach separate sheet if the space provided is insufficient. For any other information also, separate sheet may be attached.
8. Any information / clarification required by BHEL during processing of registration must be given expeditiously.
9. Please ensure that all required enclosures are attached with the filled up Supplier Registration Form and all enclosures are numbered & list of enclosures is given as required.
10. As multiple copies of the application forms are required for processing at our end, please do not spiral bound the application forms or its enclosures and instead send them in two hole clip flat file.
11. Please fill up the check- list given on next page and send along with the Supplier Registration Forms to BHEL.
12. Please note that if you are registered and participate in Tender process and qualify to get order from BHEL, your performance based on Quality of your product, delivery performance and service rendered will be evaluated inline with Chapter VI.
13. If you are attaching a document in a language other than English, a self attested English translated document may please be also attached.

	ANNEXURE 4	Document No.	AA:MM:SR:01
	CHECK-LIST FOR FOREIGN SUPPLIERS REGISTRATION FORM	Revision No.	01
		Page No.	II of II

S.N.	Check-Point	Yes/No
1.0	Information against all points in the Supplier Registration Form has been given.	
2.0	Authorisation letter has been enclosed (in case of Indian representative)	
3.0	Banker's certificate has been enclosed	
4.0	Are you an ISO: 9001 accredited supplier?	
4.1	If yes, have you enclosed copy of ISO 9001 accreditation certificate & "Table of Contents" of your Quality Manual?	
4.2	If no, have you enclosed written down procedure / manual of Quality Management System?	
5.0	Have you enclosed experience list/ performance certificate (as per sl. 3.0 of the form SRF(F) 01)	
6.0	List of enclosures has been furnished (as per Sl 5.0 of the form SRF(F) 01)	
7.0	All the parts of the form & enclosures have been signed by Authorised Signatory.	
8.0	D&B Report/ Creditreform report etc. has been attached.	

Date :

Signature & seal

(Authorised Signatory)

Note : This check list is to be attached with the filled up Supplier Registration Form.

BHARAT HEAVY ELECTRICALS LIMITED, INDIA

ANNEXURE 4

FORM NO. SRF(F)01 : (FOREIGN SUPPLIER)

Page 2 of 2

- 1.8 YEAR OF COMMENCEMENT OF BUSINESS :
- 1.9 PRODUCTION CAPACITY PER ANNUM (details of major manufacturing/ testing facilities to be given) :
- 1.10 PARTICULARS OF PRODUCTS INCLUDING SPECIFICATION AND RANGE OFFERED FOR REGISTRATION : (ATTACH BROCHURES AND CATALOGUES)
- 1.11 NAME (S) OF BANKERS :
- 1.12 BANKER'S CERTIFICATE AS TO CREDITWORTHINESS OF THE CLIENT (Enclose Certificate) :
- 1.13 PORT OF LOADING :
- 1.14 NEAREST AIRPORT :
- 1.15 Report from D&B/ Creditreform etc. (As per Cl. 7.1 of Chapter V) (**MANDATORY**):

2.0 FINANCIAL INFORMATION : (FOR LAST 3 YEARS)

PARAMETER	YEAR -1	YEAR -2	YEAR -3
ANNUAL TURN OVER			
PROFIT AFTER TAX			

(COPY OF AUDITED ANNUAL ACCOUNTS FOR LAST 3 YEARS TO BE ENCLOSED)

3.0 QUALITY MANAGEMENT SYSTEM :

- 3.1 IS THE COMPANY ISO:9001 CERTIFIED : YES / NO
- 3.1.1 IF YES, ENCLOSE COPY OF CERTIFICATE & TABLE OF CONTENTS OF QUALITY MANUAL.
- 3.1.2 IF NO, ENCLOSE QUALITY MANAGEMENT SYSTEM OR WRITTEN DOWN PROCEDURE

4.0 EXPERIENCE LIST/ PERFORMANCE CERTIFICATE FOR OFFERED / SIMILAR ITEMS :

(ATTACH LIST OF PRESENT CUSTOMERS WITH NAME & ADDRESS FOR OFFERED / SIMILAR TYPE & SIZE OF ITEM / EQUIPMENT FOR WHICH REGISTRATION HAS BEEN SOUGHT AND WITH WHOM YOU HAVE CONTINUOUS BUSINESS SINCE LAST THREE YEARS)

5.0 ANY OTHER INFORMATION :

6.0 LIST OF ENCLOSURES :

(BROCHURES, CATALOGUES, TECHNICAL LITERATURE ETC.)

Signature & Seal

AUTHORISED SIGNATORY

E – Mail

NAME :

TELEPHONE : (Landline):

DESIGNATION :

Mobile :

DATE :

	ANNEXURE - 5	Document No.	AA:MM:SR:01
	GUIDELINES TO INDIAN SUPPLIERS FOR FILLING-UP SUPPLIER REGISTRATION FORM	Revision No.	01
		Page No.	I of II

1. Prospective Suppliers may also visit our web site www.bhel.com (link Supplier Registration -> New Supplier Required) to know more about the requirement of new suppliers for various items in our units.
2. Registration Form may be obtained from BHEL website www.bhel.com.
3. Application for registration, with a covering letter detailing where your products can find application (if possible) in BHEL unit(s), should be sent to:

Supplier Development Cell
Unit Name:
 Bharat Heavy Electricals Ltd.
City:
 India

4. In case registration is being sought in multiple units of BHEL, please send the separate application to each unit.
5. Any clarification with respect to procedure for registration may be obtained from the Supplier Development Cell of respective BHEL unit.
6. The Supplier Registration Form has four parts:

Part A	Organisational Information	Form no. SRF(I)01 – page 1 to 10
Part B	Quality System	Form no. SRF(I)01 - page 11 to 12
Part C	Technical Competence	Form no. SRF(I)01 page 13 (if sent by BHEL)
Part D	Score Sheet (to be filled by BHEL)	Form no. SRF(I)01 page 14 to 17

The set of formats to be filled by different category of suppliers is as follows:

Sl.No	Supplier Category	Formats
1.	Indian Suppliers (manufacturers)	- Organisational Information - Quality System - Technical Competence
2.	Indian Stockist/ Trader/ Distributor/ Dealer/ Authorised Agent/ Channel partner/ Indian Sales office or Subsidiary of registered foreign principal	- Organisational Information SRF(I)01- Part A (page 1 to 10 except Sl. No. 5.1, 5.2, 6.6, 6.7, 7 & 8)

7. All columns are to be filled up properly in the space provided for. Wherever it is not applicable, please mention “Not Applicable”. The form is to be signed by the authorised signatory.
8. A separate sheet may be attached if the space provided is insufficient or additional information is to be given. Please put proper identification tag on the separately attached sheet.
9. Please ensure that all required enclosures are attached with the filled up Supplier Registration Form and all enclosures are numbered & list of enclosures is given as required.
10. As multiple copies of the application forms are required for processing at our end, please do not spiral bound the application forms or its enclosures and instead send them in two hole clip flat file.
11. Incomplete forms will be rejected.
12. Any information / clarification required by BHEL during evaluation must be given expeditiously.
13. Please note that if you are registered and participate in Tender process and qualify to get order from BHEL, your performance based on Quality of your product, delivery performance and service rendered will be evaluated inline with Chapter VI.
14. Please fill up the check- list given on next page and send along with the Supplier Registration Forms to BHEL.
15. If you are attaching a document in a language other than Hindi/ English, a self attested Hindi/ English translated document may please be also attached.

	ANNEXURE - 5	Document No.	AA:MM:SR:01
	Check List for Indian Supplier Registration Form	Revision No.	01
		Page No.	II of II

Sl.No.	Check-Point	Yes/No
1.	Information against all points under "Organizational Information" (Part-A) has been given.	
2.	All enclosures and supporting documents have been enclosed.	
3.	Summary list of enclosures has been furnished as per S.N.10 of Organisational Information form no. SRF (I) 01 & S.N 12 of Quality system form no. SRF (I) 01.	
4.	Are you an ISO 9001 accredited supplier?	
5.	If yes, have you enclosed "Table of Contents" of your Quality Manual and copy of ISO 9001 accreditation certificate?	
6.	Have you filled up Quality System format given in Part B?	
7.	Technical requirements, specifications, drawings, standards have been received from BHEL before filling up Technical Competence, Part C.	
8.	All the parts of the form & enclosures have been signed by Authorised Signatory.	
9.	Have you attached EFT details? (In original, Certified by the bank)	
10.	If you are seeking registration for a MSME company (as per MSME Act of Government of India), have you attached requisite certificate as per Act?	

Date :

Signature & seal

(Authorised Signatory)

Note: This check list is to be attached with the filled up Supplier Registration Form.

**BHARAT HEAVY ELECTRICALS LIMITED
SUPPLIER REGISTRATION FORM**

FORM NO. SRF(I) 01 (INDIAN SUPPLIER)

ANNEXURE - 5

Page 1 of 17

INFORMATION WITH * MARKS IS SCOREABLE.

PART- A : ORGANISATIONAL SOUNDNESS

ALL COLUMNS SHOULD BE PROPERLY FILLED IN THE SPACE PROVIDED FOR, WHEREVER IT IS NOT APPLICABLE, PLEASE WRITE "NOT APPLICABLE". INCOMPLETE OR INCORRECT FORMS MAY NOT BE CONSIDERED. PLEASE ATTACH SEPARATE SHEET, IF SPACE AVAILABLE IS INADEQUATE.

ALL THE PAGES OF THE FORM ARE TO BE SIGNED ALONGWITH SEAL BY THE AUTHORISED SIGNATORY

ORGANISATIONAL INFORMATION			
NAME AND CORRESPONDENCE ADDRESS OF THE SUPPLIER SEEKING REGISTRATION :-			
1.0 PRODUCTS / SYSTEMS / SERVICES FOR WHICH REGISTRATION IS APPLIED FOR :			
SL. NO.	DESCRIPTION	SIZE & RANGE	MFG. STD/ IS / DIN /BS ETC.
SUPPLIER'S AUTHORISED SIGNATORY		BHEL CERTIFIED ASSESSOR	

**BHARAT HEAVY ELECTRICALS LIMITED
SUPPLIER REGISTRATION FORM**

FORM NO. SRF(I) 01 (INDIAN SUPPLIER)

ANNEXURE - 5

Page 2 of 17

ORGANISATIONAL INFORMATION

2.0 GENERAL INFORMATION :

2.1 NAMES OF THE WORKS/DIVISION (Products manufactured at each works to be mentioned :

ADDRESS : E - Mail :

TELEPHONE : Landline

Mobile

FAX :

2.2 NAME OF CHIEF EXECUTIVE /
PROPRIETOR / PARTNER & ADDRESS :

2.3 DETAILS OF AUTHORISED SIGNATORY FOR SEEKING CLARIFICATION :

NAME :

DESIGNATION : E - Mail

:

TELEPHONE : Landline

Mobile

FAX :

SUPPLIER'S AUTHORISED SIGNATORY

BHEL CERTIFIED ASSESSOR

**BHARAT HEAVY ELECTRICALS LIMITED
SUPPLIER REGISTRATION FORM**

FORM NO. SRF(I) 01 (INDIAN SUPPLIER)

ANNEXURE - 5

Page 3 of 17

ORGANISATIONAL INFORMATION

3.0 OWNERSHIP INFORMATION : DOCUMENTS TO BE FURNISHED

3.1 GOVT. OF INDIA UNDERTAKING:

OR

STATE GOVT. UNDERTAKING :

OR

LIMITED COMPANY, :

MEMORANDUM AND
ARTICLES OF ASSOCIATION

OR

PRIVATE COMPANY :

MEMORANDUM AND
ARTICLES OF ASSOCIATION

OR

CO-OPERATIVE SOCIETY, :

SOCIETY RULES AND
BYE LAWS

OR

PARTNERSHIP FIRM, :

PARTNERSHIP DEED

OR

PROPRIETORSHIP, :

PROFESSION TAX REGN.
AND MUNICIPAL REGN.

ANY OTHER (SPECIFY) :

3.2 NATURE OF BUSINESS :

(MANUFACTURING UNIT/
ENGG CONSULTANT/ EPC CONTRACTOR)

(AGENTS/ DISTRIBUTORS/STOCKISTS/DEALERS/
TRADERS/ INDIAN SUBSIDIARY/ CHANNEL PARTNER – attach authorization
certificate of principal)

3.3 YEAR OF ESTABLISHMENT :

* 3.4 YEAR OF COMMENCEMENT OF BUSINESS :

SUPPLIER'S AUTHORISED SIGNATORY

BHEL CERTIFIED ASSESSOR

**BHARAT HEAVY ELECTRICALS LIMITED
SUPPLIER REGISTRATION FORM**

FORM NO. SRF(I) 01 (INDIAN SUPPLIER)

ANNEXURE - 5

Page 4 of 17

ORGANISATIONAL INFORMATION

4.0 REGISTRATION PARTICULARS

(FURNISH DETAILS AND ENCLOSE COPY OF CERTIFICATE FOR THE FOLLOWING)

- 4.1 PERMANENT ACCOUNT NO :
4.2 CENTRAL SALES TAX REGN NUMBER :
4.3 STATE SALES TAX / TIN NUMBER :
4.4 EXCISE DUTY REGN NUMBER :
4.5 EXCISE CONTROL CODE NUMBER :
4.6 SERVICE TAX REGN NUMBER :
4.7 CATEGORY AS PER MSMED ACT : MICRO/ SMALL/ MEDIUM
REGN NO. :
VALID UPTO :
(Attach Certificate)

5.0 TOTAL ORGANISATIONAL STRENGTH : (ATTACH ORGANISATION CHART)

- | | GRADUATE | DIPLOMA | SKILLED | NON-SKILLED |
|--|----------|---------|---------|-------------|
| ENGINEERING : | | | | |
| MANUFACTURING : | | | | |
| QUALITY : | | | | |
| COMMERCIAL /
SERVICE AFTER SALES : | | | | |
| OTHERS : | | | | |
| TOTAL : | | | | |
| * 5.1 POWER BACKUP :
(GIVE DETAILS) | YES/ NO | | | |
| * 5.2 DOES THE COMPANY SELL ITS PRODUCT DIRECTLY : | YES/ NO | | | |

SUPPLIER'S AUTHORISED SIGNATORY

BHEL CERTIFIED ASSESSOR

**BHARAT HEAVY ELECTRICALS LIMITED
SUPPLIER REGISTRATION FORM**

FORM NO. SRF(I) 01 (INDIAN SUPPLIER)

ANNEXURE - 5

Page 5 of 17

ORGANISATIONAL INFORMATION

6.0 OTHER PARTICULARS :

(FURNISH DETAILS AND ENCLOSE DOCUMENTARY EVIDENCE/ COPY OF CERTIFICATE FOR THE FOLLOWING)

* 6.1 IF THE COMPANY IS ALREADY REGISTERED WITH ANY OF BHEL UNITS, GIVE :

6.1.1. BHEL UNIT'S NAME :

6.1.2. SUPPLIER REGN. CODE NO. :

6.1.3. ITEMS FOR WHICH REGISTERED & THEIR SPECIFICATION
(ENCLOSE PROOF OF SUCCESSFUL EXECUTION OF
ONE OR MORE PURCHASE ORDERS):

* 6.2 IS THE COMPANY APPROVED BY
ASME / NTPC / NPC / EIL / DGS&D / RAILWAYS /
IBR / LLOYDS ETC FOR INTENDED
MATERIAL CATEGORY? : YES / NO
(ENCLOSE DOCUMENTARY EVIDENCE)

* 6.3 IS THE COMPANY ISO 9001 APPROVED? : YES / NO
(ENCLOSE CERTIFICATE & TOC OF QUALITY SYSTEM) :

* 6.4 IS THE COMPANY AN ISO 14000 APPROVED? : YES / NO
(ENCLOSE CERTIFICATE) :

* 6.5 IS THE COMPANY OHSAS - 18000 APPROVED?: YES / NO
(ENCLOSE CERTIFICATE)

* 6.6 TECHNICAL COLLABORATOR :
(FOREIGN OR INDIGENOUS)
(ENCLOSE DOCUMENTARY EVIDENCE)

* 6.7 R&D SET UP

6.8 DIRECTORS / PARTNERS, IF RELATED TO ANY
BHEL EMPLOYEE.

NAME :

STAFE NO. :

DESIGNATION :

Unit & DEPARTMENT :

RELATIONSHIP :

SUPPLIER'S AUTHORISED SIGNATORY

BHEL CERTIFIED ASSESSOR

**BHARAT HEAVY ELECTRICALS LIMITED
SUPPLIER REGISTRATION FORM**

FORM NO. SRF(I) 01 (INDIAN SUPPLIER)

ANNEXURE - 5

Page 6 of 17

ORGANISATIONAL INFORMATION

6.9 IF ANY EX-BHEL PERSONNEL IS EMPLOYED BY THE COMPANY, MENTION HIS / HER DETAILS OF LAST POSTING.

NAME :
STAFF NO. :
DESIGNATION :
UNIT & DEPARTMENT :
DATE OF LEAVING SERVICE :

6.10 COMPANY'S WEEKLY HOLIDAYS :

WORKS OFFICE

6.11 EXPERIENCE LIST:

(ATTACH LIST OF PRESENT CUSTOMERS WITH NAME & ADDRESS FOR OFFERED / SIMILAR TYPE & SIZE OF ITEM / EQUIPMENT FOR WHICH REGISTRATION HAS BEEN SOUGHT AND WITH WHOM YOU HAVE CONTINUOUS BUSINESS SINCE LAST THREE YEARS . ALSO ATTACH PERFORMANCE CERTIFICATES ISSUED BY ANY TWO CLIENTS FOR SUCCESSFUL EXECUTION OF THE CONTRACTS FOR LAST TWO YEARS- FOR PEM)

*6.12 DETAILS OF PENDING LEGAL ISSUES ON CONTRACTUAL ASPECTS WITH CUSTOMER , IF ANY

6.13 The following information of Bank Account of the Company, duly endorsed by the Bank (required for Electronic Fund Transfer –EFT/RTGS) is to be submitted

1. Name of the Company
2. Name of Bank
3. Name of Bank Branch
4. City/Place
5. Account Number
6. Account type
7. IFSC code of the Bank Branch
8. MICR Code of the Bank Branch
9. Details of other Bankers (for reference purpose only)

NOTE :

(i) Suppliers who have already submitted the above information are requested to submit a copy of the same.

SUPPLIER'S AUTHORISED SIGNATORY

BHEL CERTIFIED ASSESSOR

**BHARAT HEAVY ELECTRICALS LIMITED
SUPPLIER REGISTRATION FORM**

FORM NO. SRF(I) 01 (INDIAN SUPPLIER)

ANNEXURE - 5

Page 7 of 17

ORGANISATIONAL INFORMATION

7.0 MANUFACTURING FACILITIES:

***7.1 LIST OF MANUFACTURING FACILITIES/EQUIPMENTS (INCLUDING MATERIAL HANDLING FACILITY)**

SL. NO	DESCRIPTION OF MACHINE/EQUIPMENT	QUANTITY	MAKE & YEAR OF INSTALLATION	REMARKS

IN CASE OF SPACE LIMITATION, PLEASE ENCLOSE ANNEXURE / CATALOGUE WITH TAG

*** 7.2 IF IN-HOUSE MFG FACILITIES NOT AVAILABLE, INFORM SOURCE OF MFG. DETAILS ALONGWITH THEIR FACILITIES & EXPERIENCE**

SL. NO	PROCESS OUTSOURCED	NAME OF THE COMPANY	DESCRIPTION OF MACHINE / EQUIPMENT	REMARKS

IN CASE OF SPACE LIMITATION ENCLOSE ANNEXURE / CATALOGUE WITH TAG

*** 7.3 RATIO OF OUTSOURCED COST TO TOTAL PRODUCTION VALUE:**

SUPPLIER'S AUTHORISED SIGNATORY

BHEL CERTIFIED ASSESSOR

**BHARAT HEAVY ELECTRICALS LIMITED
SUPPLIER REGISTRATION FORM**

FORM NO. SRF(I) 01 (INDIAN SUPPLIER)

ANNEXURE - 5

Page 8 of 17

ORGANISATIONAL INFORMATION

8.0 INSPECTION & TESTING FACILITIES:

*** 8.1 LIST OF INSPECTION & TESTING FACILITIES / EQUIPMENT**

SL. NO	DESCRIPTION OF FACILITY/ EQUIPMENT & CAPACITY	NOS.	MAKE & YEAR OF MANUFACTURING	LAST DATE OF CALIBERATION

IN CASE OF SPACE LIMITATION ENCLOSE ANNEXURE / CATALOGUE WITH TAG

*** 8.2 IF IN-HOUSE TESTING FACILITIES NOT AVAILABLE, INDICATE SOURCE OF TESTING ALONGWITH THEIR FACILITIES & EXPERIENCE**

SL. NO	TEST	SOURCE OF TESTING	DESCRIPTION OF FACILITY/ EQUIPMENT & CAPACITY	APPROVAL OF EQUIPMENT/ PROCESS/PERSONNEL QUALIFICATION

IN CASE OF SPACE LIMITATION ENCLOSE ANNEXURE / CATALOGUE WITH TAG

Note:

In case of outsourcing of major testing such as NDT, Electrical & Mechanical Testing, no marks will be awarded. However, material composition testing by chemical method from recognized laboratory shall not attract negative marking

SUPPLIER'S AUTHORISED SIGNATORY

BHEL CERTIFIED ASSESSOR

**BHARAT HEAVY ELECTRICALS LIMITED
SUPPLIER REGISTRATION FORM**

FORM NO. SRF(I) 01 (INDIAN SUPPLIER)

ANNEXURE - 5

Page 9 of 17

ORGANISATIONAL INFORMATION					
FINANCIAL INFORMATION FOR THE PREVIOUS FOUR YEARS					
9.0	Parameter	Year 1	Year 2	Year 3	Year 4
		(Years in ascending order, Money value in Rs. Lakhs)			
* 9.1	NET WORTH (Share Capital +Reserves)				
	Growth over previous year (%)	-----			
9.2	LONG TERM DEBT / LOAN				
* 9.3	DEBT EQUITY RATIO <u>Long term Debt (9.2)</u> <u>Net worth (9.1)</u>				
9.4	INVESTMENT IN: Land & Building				
	Plant & Machinery				
	Other Fixed Assets				
9.5*	NET CURRENT ASSETS				
	1 a) Cash on hand				
	b) Account receivable				
	c) Inventories				
	Total				
	CURRENT LIABILITY				
	2 a) Sundry creditors				
	b) Interest accrued but not due				
	c) Other liabilities				
	Total				
* 3	* QUICK RATIO <u>CA - INVENT. {9.5(1)-9.5(1)c}</u> <u>Current liability {9.5 (2)}</u>				
* 9.6	SALES				
	Growth over previous year (%)	-----			
* 9.7	PROFIT BEFORE TAX				
	Growth over previous year (%)	-----			
* 9.8	Whether the supplier has been referred to BIFR / NCLT / any other Govt agency (If YES , enclose details)				YES / NO
* 9.9	Whether the supplier is a potential sick company.(If YES , enclose details)				YES / NO
NOTE: 1. Copies of annual accounts (Balance Sheet) for the last four years (or from date of incorporation which ever is less) along with audit report are to be submitted. The above details shall be highlighted in the Balance Sheet. 2. Status of Tax assessments done under various laws (Income Tax, VAT/Sales Tax, Excise & Service Tax, Custom) and details of disputes pending, if any, with these authorities to be submitted.					
SUPPLIER'S AUTHORISED SIGNATORY			BHEL CERTIFIED ASSESSOR		

**BHARAT HEAVY ELECTRICALS LIMITED
SUPPLIER REGISTRATION FORM**

FORM NO. SRF(I) 01 (INDIAN SUPPLIER)

ANNEXURE - 5

Page 10 of 17

ORGANISATIONAL INFORMATION

10. LIST OF ENCLOSURES (Tags to be put on enclosures) :

- (i) MEMORANDUM AND ARTICLES OF ASSOCIATION / SOCIETY RULES AND BYE LAWS / PARTNERSHIP DEED/ PROFESSION TAX REGN & MUNICIPAL REGN. : YES / NO
- (ii) Copy of certificate of following:-
 - x PERMANENT ACCOUNT NO : YES / NO
 - x CENTRAL SALES TAX REGN NUMBER : YES / NO
 - x STATE SALES TAX / TIN NUMBER : YES / NO
 - x EXCISE DUTY REGN NUMBER : YES / NO
 - x EXCISE CONTROL CODE NUMBER : YES / NO
 - x SERVICE TAX REGN NUMBER : YES / NO
 - x REGN NUMBER OF CATEGORY AS PER MSMED ACT : YES / NO
- (iii) ORGANISATION CHART : YES / NO
- (iv) If registered with any other BHEL Unit,
 - x LETTER OF REGISTRATION WITH BHEL UNIT : YES / NO
 - x PROOF OF SUCCESSFUL EXECUTION OF ONE OR MORE PURCHASE ORDERS : YES / NO
- (v) Letter of approval from ASME / NTPC / NPC / EIL / DGS&D / RAILWAYS /IBR / LLOYDS ETC : YES / NO
- (vi) Accreditation certificate for
 - x ISO: 9001 : YES / NO
 - x TOC of Quality System Manual : YES / NO
 - x ISO : 14000 : YES / NO
 - x OHSAS , ISO 18000 : YES / NO
- (vii) Letter regarding technical collaboration : YES / NO
- (viii) Experience List / Performance certificate : YES / NO
- (ix) Balance Sheet for the last four years along with audit Report : YES / NO
- (x) Principal's authorization in case of dealers/ agents : YES / NO
- (xi) EFT Bank's certificate : YES / NO

I /WE GIVE THE UNDERTAKING THAT BHEL DRAWINGS & SPECIFICATIONs SHALL NOT BE USED IN ANY WAY DETRIMENTAL TO THE INTEREST OF BHEL AND/ OR FOR SUPPLY OF ANY MATERIAL, PRODUCT OR SERVICES DIRECTLY OR INDIRECTLY TO ANY OTHER CUSTOMER.

Maximum Marks = 50
Negative Marks = -13
Minimum Qualifying marks = 30

**BHARAT HEAVY ELECTRICALS LIMITED
SUPPLIER REGISTRATION FORM**

FORM NO. SRF(I) 01 (INDIAN SUPPLIER)

ANNEXURE - 5

Page 11 of 17

FORM NO. SRF(I) 01

Part B (QUALITY SYSTEM):

Sl. No	PARAMETERS	SYSTEM IN EFFECT (Tick if exists & provide evidences if ticked in written procedure)		RECORDS (Tick if available & submit evidences)	REMARKS
		Written Procedure	Practice		
1*	Incoming Material Control System				Furnish a copy of system and organization.
2*	In process control				Furnish at least one work instruction & record of process control parameter
3*	Manufacturing / Testing Procedure Qualification				Procedure Qualification specification may be submitted
4*	Personnel qualification for 3 above.				Record of Personnel qualification (PQR) to be submitted
5*	Calibration system				Submit list of instrument & their calibration status
6*	System of Identification & Traceability of materials, tools, jigs, fixtures & processed components, etc.				Copy of procedure to be submitted
7*	System of Storage, Preservation , Painting & packing				Copy of procedure to be submitted
8*	System of NCR disposition & corrective preventive action				Two copies of NCR & CAPA
9*	Customer complaints handling system				Submit list of customer complaints & status for the last three years
10*	Safety measures				Submit copy of safety system & Record of accidents for last three years
11	Any other quality initiative				

SUPPLIER'S AUTHORISED SIGNATORY

BHEL CERTIFIED ASSESSOR

**BHARAT HEAVY ELECTRICALS LIMITED
SUPPLIER REGISTRATION FORM**

FORM NO. SRF(I) 01 (INDIAN SUPPLIER)

ANNEXURE - 5

Page 12 of 17

FORM NO. SRF(I) 01

Part B (QUALITY SYSTEM):

12. LIST OF ENCLOSURES

- (i) Copy of system of control incoming materials and organization chart
- (ii) Copy of at least one process control work instruction
- (iii) Record of process control parameter
- (iv) Copy of at least one Procedure Qualification specification
- (v) Record of Personnel qualification (PQR)
- (vi) List of instrument & their calibration status
- (vii) Copy of procedure for Identification & Traceability of materials, tools, jigs, fixtures & processed components, etc.
- (viii) Copy of procedure for Storage/ preservation/ painting & packing
- (ix) Copies of two NCRs and their CAPA.
- (x) List of customer complaints & status for the last three years
- (xi) Copy of safety system
- (xii) Record of accidents for last three years

Maximum Marks = 25

Minimum Qualifying marks = 15

SUPPLIER'S AUTHORISED SIGNATORY

BHEL CERTIFIED ASSESSOR

**BHARAT HEAVY ELECTRICALS LIMITED
SUPPLIER REGISTRATION FORM**

FORM NO. SRF(I) 01 (INDIAN SUPPLIER)

ANNEXURE - 5

Page 13 of 17

FORM NO. SRF(I)01

Part C : TECHNICAL COMPETENCE

Technical competence shall be evaluated in two parts viz. common competence and product/material category specific competence.

(i) COMMON TECHNICAL COMPETENCE (Max Marks: 10)

TECHNICAL COMPETENCE (where design specification is given by BHEL)	MARKING RANGE	SUPPLIER RESPONSE (ALONG WITH SUPPORTING DOCUMENTS)#	MARKS BY BHEL
1. Supplier understands the product specification.	(0-3)		
2. Supplier understands the inspection requirements.	(0-2)		
3. Supplier has process capability to achieve the product specification/dimensional requirement.	(0-3)		
4. Supplier has experienced manpower to carry out the job.	(0-2)		
TOTAL MARKS OUT OF POSSIBLE (10) = ---			

OR

TECHNICAL COMPETENCE (where performance specification is given by BHEL)	MARKING RANGE	PROCEDURE		SYSTEM IN EFFECT		RECORDS	
		SUPPLIER RESPONSE (ALONG WITH SUPPORTING DOCUMENTS)#	MARKS BY BHEL	SUPPLIER RESPONSE (ALONG WITH SUPPORTING DOCUMENTS)#	MARKS BY BHEL	SUPPLIER RESPONSE (ALONG WITH SUPPORTING DOCUMENTS)#	MARKS BY BHEL
1. Design capability	(0-3)						
2. Adequacy of quality assurance plan	(0-2)						
3. Process capability for components	(0-3)						
4. Adequate of testing	(0-2)						
TOTAL MARKS OUT OF POSSIBLE (10)							
Average of Total (Total/3) = -----							

(ii) PROUCT/ MATERIAL CATEGORY SPECIFIC TECHNICAL COMPETENCE

(Max Marks: 15)

Unit MISCC to structure the parameters to be considered for the technical competence depending on material category. The score of individual parameter selected is to be decided by MISCC. MISCC shall identify the requirement of enclosures to be furnished by supplier

Product:

Sl. No	Material category	Tech Parameter	Supplier's response	Remarks

To be filled up only on receipt of technical requirements/ specification, drawings, standards from BHEL and to be sent to BHEL for further scrutiny. Enclose documentary evidence where ever required.

LIST OF ENCLOSURES:

Maximum Marks = 25

Minimum Qualifying marks = 15

No marks is to be given by the supplier. Only supplier response along with supporting documents,

SUPPLIER'S AUTHORISED SIGNATORY	BHEL CERTIFIED ASSESSOR
---------------------------------	-------------------------

BHARAT HEAVY ELECTRICALS LIMITED SUPPLIER REGISTRATION FORM

FORM NO. SRF(I) 01 (INDIAN SUPPLIER)

ANNEXURE - 5

Page 14 of 17

Part D : SCORE SHEET

1. ORGANISATIONAL SOUNDNESS (for Manufacturers):

S.N.	PARAMETER	CRITERIA	Maxm. Marks	Marks Awarded
1.	Whether all relevant information like ownership, PAN no., sales tax no., excise duty no., etc. submitted	Yes: 2 No: 0	2	
2.	3.4 YEAR OF COMMENCEMENT OF BUSINESS	More than 5 years : 2 1-5 years : 1 Less than 1 year : 0	2	
3.	5.1 POWER BACKUP	Yes : 1 No : 0	1	
4.	5.2 DOES THE COMPANY SELL ITS PRODUCT DIRECTLY	Yes : 1 No : 0	1	
5.	6.1 REGISTERED WITH ANY OF BHEL UNITS	Yes (same item) : 2 Yes (another item) : 1 No : 0	2	
6.	6.2 APPROVAL BY ASME/ NTPC/ NPC/ EIL/ DGS&D/ RAILWAYS/ IBR/ LLOYDS ETC	Yes : 2 No : 0	2	
7.	6.3 ISO 9001 ACCREDITATION	Yes : 3 No : 0	3	
8.	6.4 ISO 14000 ACCREDITATION	Yes : 1 No : 0	1	
9.	6.5 OHSAS - 18000 ACCREDITATION	Yes : 1 No : 0	1	
10.	6.6 TECHNICAL COLLABORATOR : (FOREIGN OR INDIGENOUS)	Yes : 1 No : 0	1	
11.	6.7 R & D SET UP	Yes : 1 No : 0	1	
12.	6.12 PENDING LEGAL ISSUES ON TECHNO – COMMERCIAL ASPECTS WITH CUSTOMER	Yes : -5 No : 0	0	
13.	7.1 & 7.2 MANUFACTURING FACILITIES INCLUDING OUTSOURCING	Adequate : 3 Substantial : 2 Inadequate : 0	3	
14.	7.3 RATIO OF OUTSOURCED COST TO TOTAL PRODUCTION VALUE	Less than 10% : 2 10 to 30 % : 1 More than 30% : 0	2	
15.	8.1 INSPECTION & TESTING FACILITIES	Adequate : 2 Substantial : 1 Inadequate : 0	2	
16.	8.2 OUTSOURCING OF MAJOR TESTING FACILITY (Refer Note)	Yes : 0 No : 1	1	
	TOTAL		25	

1. ORGANISATIONAL SOUNDNESS (for Indian Stockist/ Trader/ Distributor/ Dealer/ Authorised Agent/ Channel partner/ Indian Sales office or Subsidiary of registered foreign principal):

S.N.	PARAMETER	CRITERIA	Maxm. Marks	Marks Awarded
1.	Whether all relevant information like ownership, PAN no., sales tax no., etc. submitted (clause 6.0 of chapter V to be referred in this regard)	Yes: 7 No: 0	7	
2.	3.4 YEAR OF COMMENCEMENT OF BUSINESS	More than 3 years : 2 1-3 years : 1 Less than 1 year : 0	2	
3.	6.1 REGISTERED WITH ANY OF BHEL UNITS	Yes (same item) : 2 Yes (another item) : 1 No : 0	2	
4.	6.2 APPROVAL BY ASME/ NTPC/ NPC/ EIL/ DGS&D/ RAILWAYS/ IBR/ LLOYDS ETC	Yes : 2 No : 0	2	
5.	6.3 ISO 9001 ACCREDITATION	Yes : 2 No : 0	2	
6.	6.12 PENDING LEGAL ISSUES ON TECHNO – COMMERCIAL ASPECTS WITH CUSTOMER	Yes : -5 No : 0	0	

BHEL CERTIFIED ASSESSOR

**BHARAT HEAVY ELECTRICALS LIMITED
SUPPLIER REGISTRATION FORM**

FORM NO. SRF(I) 01 (INDIAN SUPPLIER)

ANNEXURE - 5

Page 15 of 17

Part D: SCORE SHEET

2. FINANCIAL INFORMATION (for Manufacturers):

S.N.	PARAMETER	CRITERIA	Maximum Marks	Marks Awarded
1.	9.1 Growth of Net Worth over previous year (%) Average of three years to be worked out	More than 20 % : 5 10 – 20 % : 4 5 – 10 % : 3 > 0 & < 5 % : 2 0 or below : 0	5	
2.	9.3 DEBT EQUITY RATIO <u>Long term Debt (9.2)</u> Net worth (9.1)	1 : 1 : 5 1.1 upto 1.5 : 1 : 4 1.6 upto 2.0 : 1 : 3 2.0 & above : 1 : 2	5	
3.	9.5 QUICK RATIO <u>CA - INVENTORIES {9.5(1)-9.5(1)c}</u> Current liability {9.5 (2)}	1 : 1 : 5 1 : 1 upto 1.5 : 4 1 : 1.5 upto 1.75 : 3 1 : 1.75 upto 2.5 : 2 1 : > 2.5 : 0	5	
4.	9.6 Growth in Sales over previous year (%) Average of three years to be worked out	More than 35% : 5 20 -35 % : 4 10 – 20 % : 3 5 – 10 % : 2 > 0 & < 5 % : 1 0 or negative : 0	5	
5.	9.7 PROFIT BEFORE TAX Growth over previous year (%)	More than 20 % : 5 10 – 20 % : 4 5 – 10 % : 3 > 0 & < 5 % : 2 0 or below : 0	5	
6.	9.8 Whether the supplier has been referred to BIFR / NCLT/ any other similar Govt agency	Yes: -5 No : 0	0	
7.	9.9 Whether the supplier is a potentially sick company	Yes: -3 No : 0	0	
TOTAL			25	

Note: If the supplier is new in business and does not have past data, then the evaluation will be done on the basis of information provided by him and will be decided by MISCC.

2. FINANCIAL INFORMATION (for Indian Stockist/ Trader/ Distributor/ Dealer/ Authorised Agent/ Channel partner/ Indian Sales office or Subsidiary of registered foreign principal):

S.N.	PARAMETER	CRITERIA	Maximum Marks	Marks Awarded
1.	9.6 Growth in Sales over previous year (%) Average of three years to be worked out	More than 35% : 5 20 -35 % : 4 5 - 20 % : 3 >0 - 5 % : 2 0 or negative : 0	5	
2.	9.7 PROFIT BEFORE TAX Growth over previous year (%)	More than 20 % : 5 5 – 20 % : 4 >0 – 5 % : 3 0 or below : 0	5	

BHEL CERTIFIED ASSESSOR

**BHARAT HEAVY ELECTRICALS LIMITED
SUPPLIER REGISTRATION FORM**

FORM NO. SRF(I) 01 (INDIAN SUPPLIER)

ANNEXURE - 5

Page 16 of 17

Part D : SCORE SHEET

3. QUALITY SYSTEM :

S.N.	PARAMETER	CRITERIA	Maxm. Marks	Marks Awarded
1.	Incoming Material control System	System availability : Yes: 1 No : 0	1	
		Availability of Organisation chart Yes: 1 No : 0	1	
2.	Process control	Work instruction available: Yes: 1 No : 0	1	
		Record of process Control : Available : 2 Partial record : 1 Not available: 0	2	
3.	Manufacturing / Testing Procedure Qualification	Procedure Qualification Specification : Adequate : 3 In adequate: 1 Not available : 0	3	
4.	Personnel qualification	Record of PQR: Adequate : 3 In adequate: 1 Not available : 0	3	
5.	Calibration system	Adequate : 3 In adequate: 1 Not available : 0	3	
6.	System of Identification & Traceability of materials, tools, jigs, fixtures & processed components, etc.	Procedure available : Adequate : 2 In adequate: 1 Not available : 0	2	
7.	System of Storage/ preservation/ painting & packing	Procedure available : Adequate : 2 In adequate: 1 Not available : 0	2	
8.	System of NCR disposition & corrective preventive action	Two copies of NCR & CAPA Available :2 Not available : 0	2	
9.	Customer complaints handling system	System available : Yes: 1 No : 0	1	
		Complaints registered & resolved : 2 Complaints registered & partially resolved : 1 Complaints not registered or not resolved : 0	2	
10.	Safety measures	System available : Yes: 1 No : 0	1	
		Record available : Yes: 1 No : 0	1	
TOTAL			25	

BHEL CERTIFIED ASSESSOR

**BHARAT HEAVY ELECTRICALS LIMITED
SUPPLIER REGISTRATION FORM**

FORM NO. SRF(I) 01 (INDIAN SUPPLIER)

ANNEXURE - 5

Page 17 of 17

Part D : SCORE SHEET

4. TECHNICAL COMPETENCE

Column no. 1 to 4 to be filled by MISCC before sending to supplier. Column no. 5 to be filled by BHEL certified Assessor after evaluation of supplier response.

Sl. No (1)	Parameter (2)	Scoring criteria (3)	Maximum Marks (4)	Marks obtained (5)
	TOTAL		25	

SUMMARY:

Sl. No	Criteria	Maxm Marks	Qualifying marks *	Marks obtained	Recommendation for registration
1.	Organisational Soundness	50	30		Recommended : Permanent code /Development code/ Trial code Not recommended
	Financial Information				
2.	Quality System	25	15		
3.	Technical Competence	25	15		
	TOTAL	100	60		

***Minimum Qualifying Score in Each category shall be 60%.**

REGISTRATION CRITERIA:

Sl. No	Score	Recommendation
1.	More than 90	Supplier is to be registered and given Permanent code, Normally no visit is called for.
2.	>75 <=90	Supplier may be visited if recommended by MISCC or to be registered and given permanent code.
3.	>=60 <=75	Supplier may carry out suggested improvements if advised by MISCC Supplier's visit is mandatory. Trial/ Development code may be given.
4.	Less than 60	Not to be registered

Note: Indian Stockist/ Trader/ Distributor/ Dealer/ Authorised Agent/ Channel partner/ Indian Sales office or Subsidiary of registered foreign principal are to be awarded marks on pro-rata basis and registered accordingly.

Signatures: MISCC and Suppler Evaluation Team (in case of visit)

1)

2)

3)

4)

5)

6)

BHEL CERTIFIED ASSESSOR

ANNEXURE - 6

NON-DISCLOSURE AND PROPRIETARY INFORMATION AGREEMENT

BETWEEN

_____ (Name of the Vendor), having its registered offices in
_____ (Address of Vendor), registered under the no.
of the Companies' register of _____ (Name of Place and Country),
capital stock of _____ (Value), with a place of business in
_____ (Name of Place and Country) (hereinafter referred to as
" _____ (Name of Vendor)");

AND

Bharat Heavy Electricals Ltd a company incorporated under the Indian Companies Act 1956 having its registered offices at BHEL House, Siri Fort, New Delhi -110 049 and having one of its works at Heavy Electrical Equipment Plant, Ranipur, Haridwar-249403 (Uttarakhand), India registered under the No. 4281 of 1964-65 of the companies register of Delhi, capital stock of Rs 4895.2 million with a place of registered office in New Delhi (hereinafter referred to as "BHEL") hereinafter also referred to individually as "the Party" or collectively as "the Parties".

BACKGROUND

This Agreement sets forth the rights and obligations of the Parties with respect to the use, handling, protection and safeguarding of Proprietary Information that is disclosed by and between the Parties.

WHEREAS

A) the Parties wish to pursue exploratory discussions concerning a possible collaboration between them in relation to the Program defined in Exhibit 1;

B) during the ensuing discussions and negotiations it may occur that either Party discloses to the other technical, financial or business information of a proprietary or confidential nature, which the Parties intend to protect against, making it available, by any means to any third person, and other unauthorized use and/or further disclosure by the recipient, in accordance with the terms and conditions set forth herein;

NOW, THEREFORE, the Parties have agreed as follows:

1. The term “Proprietary Information” shall mean any information or data of whatsoever kind of a confidential or proprietary nature, including but not limited to, commercial information, know how and technical information in the form of designs, drawings, concepts, requirements, specifications, software, interfaces, components, processes, or the like, that have been or will be disclosed by either Party to the other pursuant to this Agreement, either in writing, orally or other form, which is designated as “Proprietary” or “Confidential” by the disclosing Party by means of formal declaration or an appropriate stamp, legend or any other written or orally notice .

2. Proprietary Information may be conveyed, without limitation, through any written or printed documents, samples, models, electronic form on disk, tape, other storage media or any other means of disclosing such Proprietary Information that either Party may elect to use during the life of this Agreement, but if an originating Party originally discloses information orally or visually, the receiving Party will protect such information as Proprietary Information to the extent that the originating Party :
 - identifies the Information as Proprietary at the time of original disclosure,
 - summarizes the Proprietary Information in writing .

Information stored in electronic form on disk, tape, other storage media will be adequately marked if a proprietary legend displays when the information originally runs on a computer system and when the information is printed from its data file.

Proprietary Information also includes any information which can be obtained by examination, testing or analysis of any hardware or material substance or any component part of such hardware or material substance provided by the Disclosing Party even though the requirements in Clause 1 for marking and designation have not been fulfilled.

3. Each Party, to the extent of its rights to do so, shall disclose to the other only the Proprietary Information which the disclosing Party deems appropriate to fulfil the objectives of this Agreement. The Parties hereby represent that the disclosure of Proprietary Information by and between themselves shall be made in compliance with, and subject to the laws and regulations of the Disclosing Party's country.

4. The receiving Party hereby agrees and covenants that, from the effective date of this Agreement until the expiry date as per article 11 and the following period as per article 12, the Proprietary Information that either Party receives from the other shall:
 - a) be protected and kept in strict confidence by the receiving Party which must use the same degree of care it uses to protect its own confidential information and in no case less than a reasonable care;

 - b) be only disclosed to and used by those persons within the receiving Party's organization or that of its parent or controlled companies who have a need to know and solely for the purposes specified in this Agreement, and be treated by such persons or entities with the same degree of care and subject to the same restrictions;

 - c) to procure that each third party to whom Proprietary Information is disclosed under this Agreement is made aware of the provisions of this Agreement prior to such disclosure to it and that each such third party is

bound by obligations of confidentiality which are no less onerous than those contained in this Agreement;

- d) neither be disclosed nor caused to be disclosed or made available, either directly or indirectly, to any third Party or persons other than those mentioned in subparagraph b) above or other persons upon which both of the contractual Parties shall agree in an amendment to this Agreement;
- e) not to copy, reproduce or reduce to writing any part of such Proprietary Information except as may be reasonably necessary for the purpose referred to in the Recitals of this Agreement

PROVIDED THAT the Receiving Party shall be entitled to make any disclosure required by court order or government or regulatory requirement of the Disclosing Party's Proprietary Information subject to notifying the Disclosing Party as soon as possible of such requirement

- 5. Any Proprietary Information and copies thereof disclosed by either Party to the other shall remain the property of the disclosing Party and shall be immediately returned or destroyed by the receiving Party upon request.
- 6. The receiving Party shall have no obligations or restrictions with respect to any Proprietary Information for which the receiving Party can prove that:
 - a) is in or which comes into the public domain otherwise than as a result of a breach of this Agreement by any person to whom a disclosure of Proprietary Information is made as permitted under this Agreement or of any other duty of confidentiality relating to the Proprietary Information of which the Receiving Party has knowledge; or
 - b) it has been in its possession without restriction at the time of the disclosure, as evidenced by written documentation in its files; or
 - c) it has been lawfully received from a third Party without breach of this Agreement; or

- d) it has been or is published without violation of this Agreement; or
 - e) it has been independently developed in good faith by employees of the receiving Party who did not have access to the Proprietary Information; or
 - f) it has not been properly declared, designated or confirmed as Proprietary or Confidential; or
 - g) the protection period has expired according to articles 11 and 12 of this Agreement.
7. With respect to any exchange of Proprietary Information which may occur as a result of this Agreement, it is expressly understood and agreed that the persons listed in Exhibit 2 shall, on behalf of the respective Parties, be the exclusive individuals authorized to receive from and transmit to the other Party Proprietary Information under this Agreement. Each Party may replace at any time its respective authorized individuals identified in such Exhibit 2, within its own organization. Any such new designation by a Party shall be made by written notice to the other at the address indicated in such Exhibit 2.
8. Any Proprietary Information which is identified as “Classified Information”, or whose export is subject to an export license, shall be identified as such by the disclosing Party at the time of disclosure and the disclosure, protection, use and handling thereof, shall remain subject to the security procedures and restrictions imposed by the disclosing Party's Government.
9. The disclosure of Proprietary Information under this Agreement by either Party to the other shall not be construed as granting to the receiving Party any right, whether express or implied by licence or otherwise, on the matters, inventions or discoveries to which such information pertains, or as granting any trademark, patents, copyrights, trade secret right or other form of intellectual property right.

10. Nothing in this Agreement may be construed as an obligation of either Party to disclose any Proprietary Information to the other, or to enter into any subsequent contractual relationship with such other Party.
11. This Agreement covers the exchange of Proprietary Information which may be made by either Party to the other until ten years from signing of the agreement or any extension thereto which may be agreed upon by the Parties in writing. Proprietary information relevant to the Program detailed in Exhibit 1, already made available to the other contractual Party before the effective date, shall also be protected under this Agreement.

It is understood by the parties that, prior to disclosure, the Disclosing Party shall have obtained any government authorisation needed for the export of the Proprietary Information

12. The expiry of the period contemplated in Article 11 of this Agreement shall not relieve the receiving Party from complying with the obligations imposed by Article 4 here above with respect to the use and protection of the Proprietary Information, received prior the date of such expiry, for a period of ten (10) years after such expiry.
13. The Parties are independent contractors. Each will bear all costs and expenses in connection with this Agreement. This Agreement is intended to facilitate only the exchange of Proprietary Information and is not intended to be, and shall not be construed to create a teaming agreement, joint venture, association, partnership, or other business organisation or agency arrangement and no Party shall have the authority to bind the other without the other Party's separate prior written agreement .
14. This Agreement shall be governed by and shall be interpreted in accordance with the substantive federal laws of Switzerland excluding it's choice of law rules.

Irrespective of the foregoing each Party shall remain bound by the provisions of its own national laws and regulations with respect to the transfer or use of Classified Information or information whose export is subject to an export license.

15. All disputes among the Parties, in connection with or arising out of the existence, validity, construction, performance and termination of this Agreement (or any terms thereof), which the Parties are unable to resolve among themselves, shall be finally settled by an Arbitration. The Arbitration shall be held in Geneva (CH) in English language, in accordance with the rules of the ICC – International Chamber of Commerce by three arbitrators appointed in accordance with said rules.
16. The foregoing constitutes the entire Agreement among the Parties with respect to the subject matter hereof and supersedes and cancels all prior representations, negotiations, commitments, undertakings, communications, either oral or written, acceptances, understandings and agreements among the Parties with respect to or in connection with any of the matters to which such Agreement applies or refers.
17. Notices to _____ (**Name of Vendor**) shall be made at the following address:

(Complete Address of Vendor)

Attention: Mr. _____ (**Name of the Authorised Person of Vendor**)

Notices to BHEL shall be made at the following address:

BHARAT HEAVY ELECTRICALS LIMITED,

HEAVY ELECTRICAL EQUIPMENT PLANT,

Ranipur, Haridwar-249403 (Uttarakhand), India

Attention: Shri B.M.Bansal, General Manager- Materials Management

18. The effective date of this Agreement shall be the date of the last signature appearing herein.

IN WITNESS WHEREOF, each of the Parties has caused this Agreement, to be executed by its duly authorized officer.

Date :

Signed for and on behalf of

Signed for and on behalf of

(Name of Vendor)

BHEL

By:

By:

Title:

Title:

Signature:

Signature:

EXHIBIT 1

to the

NON-DISCLOSURE AGREEMENT

between

_____ **(Name of Vendor)**

and

BHARAT HEAVY ELECTRICALS LIMITED

dated:

The Non Disclosure Agreement covers the exchange of Proprietary Information which may occur during the discussions and negotiations in view of a possible cooperation between the Parties in the following programs:

-Description of Material or Services for which the order is placed

_____ **(Name of Vendor)** list of products that require an exchange of Proprietary Information which may be occur during the discussions and negotiations in view of a possible cooperation for the above programs :

Certificate by Chartered Accountant on letter head

This is to Certify that M/S
(hereinafter referred to as 'company') having its registered office at
..... is registered under MSMED Act 2006, (Entrepreneur
Memorandum No (Part-II) dtd:.....
Category: (Micro/Small). (Copy enclosed).

Further verified from the Books of Accounts that the investment of the company as on
date..... as per MSMED Act 2006 is as follows:

1. **For Manufacturing Enterprises:** Investment in plant and machinery (i.e. original cost
excluding land and building and the items specified by the Ministry of Small Scale Industries vide its
notification No.S.O.1722(E) dated October 5, 2006 :
Rs.....Lacs
2. **For Service Enterprises:** Investment in equipment (original cost excluding land and building and
furniture, fittings and other items not directly related to the service rendered or as may be notified under the MSMED
Act, 2006:
Rs.....Lacs

The above investment of Rs.....Lacs is within permissible limit of
Rs.....Lacs forMicro / Small (Strike off which is not applicable)
Category under MSMED Act 2006.

Date:

(Signature)

Name -

Membership number -

Seal of Chartered Accountant

