

FOR TOLERANCES OF UNTOLERANCED DIMENSIONS DURING MANUFACTURE REFER RELEVANT QCP/QP

REV	DATE	ALTERED
		CHD & APPD

25/ ( 12.5/ 1.6/ )

CAUTION: The information on this document is the property of BHARAT HEAVY ELECTRICALS LTD. It must not be used directly or indirectly in any way detrimental to the interest of the company.

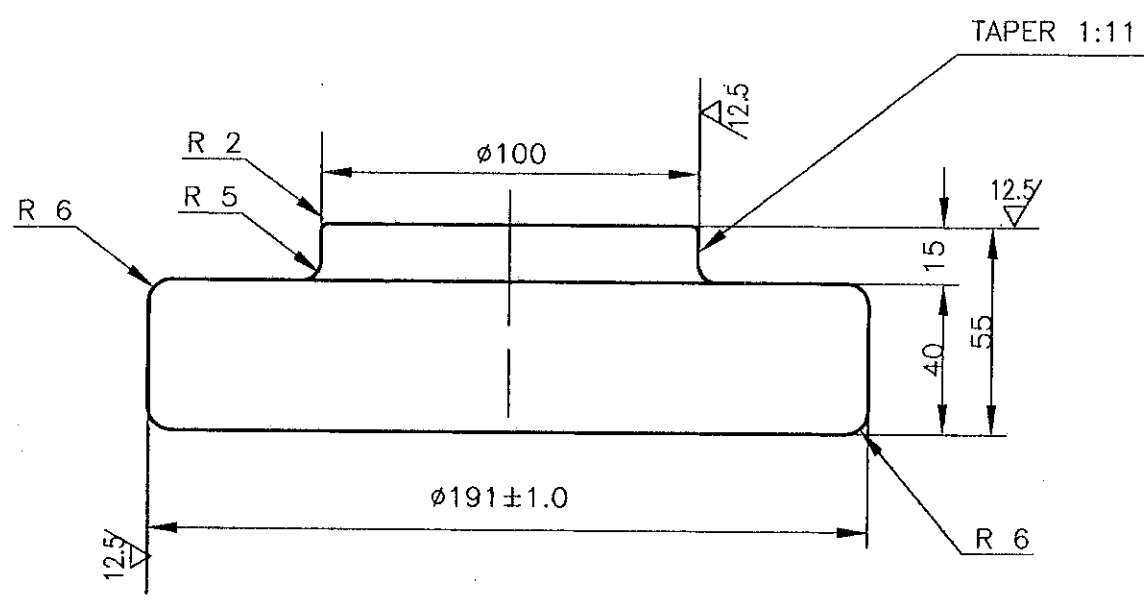

**NOTES:**

01. FOR QUALITY REQUIREMENTS REFER LATEST APPLICABLE QUALITY PROCEDURE.

FORGING	92012196	SA 105 ATTEST	NORMALISED	-	9.820	-	-	01	
NO OFF	DESCRIPTION	MATL CODE	MATL SPECN	HEAT TREATMENT	SCRAP SORT	NET WT (kg)	GROSS WT (kg)	DRAWING No	ITEM No
BHARAT HEAVY ELECTRICALS LTD., UNIT: HIGH PRESSURE BOILER PLANT, TIRUCHIRAPALLI 620014.				DRN	V.ARUMUGAM	SIGN		DATE	NO.OF VAR
				CHD	K.SRIDHARAN	Bidarani		10-08-2k	
				APPD	S.NATARAJAN	Sripa		10.08.2k	
DEPT VL		SCALE	WEIGHT (KG).	REFERENCE INFORMATIONS				NO. OF ITEMS	
CODE	330	N.T.S	9.820						
TITLE				CARD CODE	DRAWING NO.			REV	
FLANGE (RAW FORGING)				U 01	4-20-001-02723			00	

REV	DATE	ALTERED
		CHD & APPD

25 / ( 12.5 / 1.6 )

CAUTION: The information on this document is the property of BHARAT HEAVY ELECTRICALS LTD. It must not be used directly or indirectly in any way detrimental to the interest of the company.

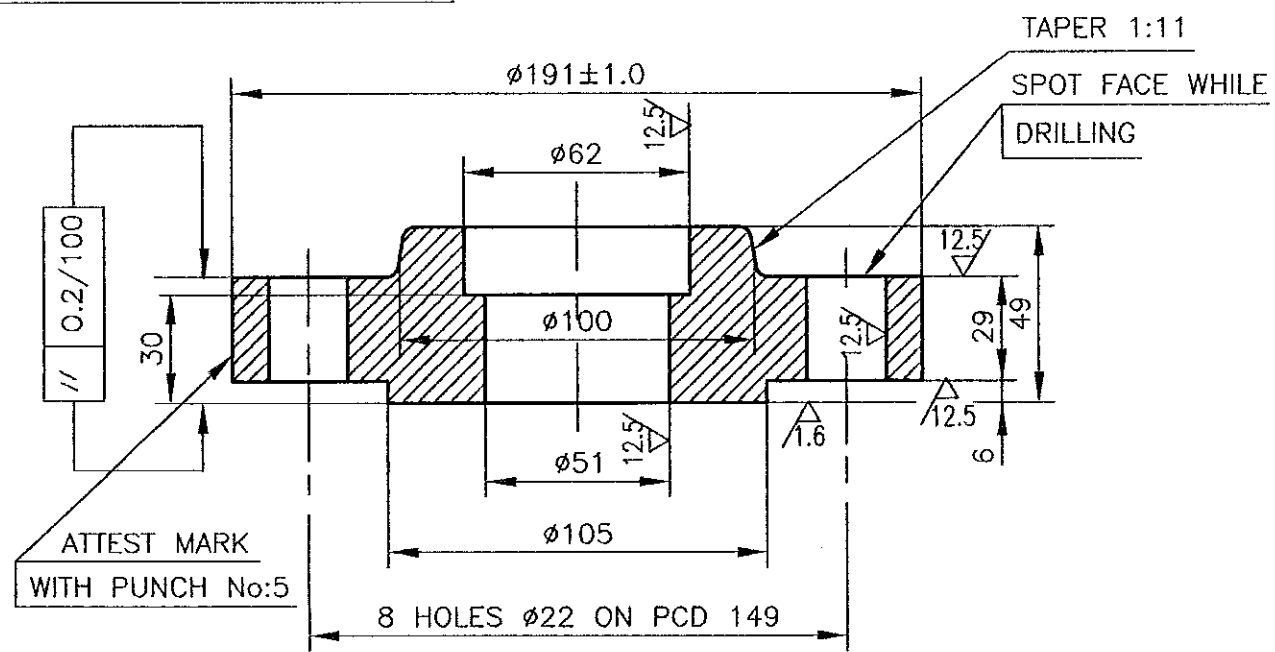

**NOTES:**

- SHARP CORNERS TO BE ROUNDED OFF.
- FOR QUALITY REQUIREMENTS REFER LATEST APPLICABLE QUALITY PROCEDURE.
- TO STAMP:  
MANUFACTURES MARK:  
INSPECTION  
ANSI B16.5  
SIZE 2.5",600#
- MAX WORKING PRESSURE : 54 KG/CM<sup>2</sup>
- MAX WORKING TEMP.500°C
- DIMENSIONS & MATERIALS AS PER ANSI B16.5 Nb2 1/2" -600 CLASS

COMPONENT CODE: 842000130000

-	FORGING ROUND	-	A182F22 CL3 ATTEST	N & T	-	6.1	-	-	01
NO OFF	DESCRIPTION	MATL CODE	MATL SPECN	HEAT TREATMENT	SCRAP SORT	NET WT (kg)	GROSS WT (kg)	DRAWING No	ITEM No
BHARAT HEAVY ELECTRICALS LTD., UNIT: HIGH PRESSURE BOILER PLANT. TIRUCHIRAPALLI 620014.					DRN	NAME	SIGN	DATE	NO.OF VAR
					CHD	K.SRIDHARAN	<i>K.Sridharan</i>	21/12/2K	
					APPD	S.NATARAJAN	<i>S.Natarajan</i>	21/12/2K	
DEPT VL		SCALE	WEIGHT (KG).	REFERENCE INFORMATION				NO. OF ITEMS	
CODE	330	N.T.S	6.1						
TITLE					CARD CODE	DRAWING NO.			REV
COMPANION FLANGE					U 01	4-20-001-02769			00

**Certificate by Chartered Accountant on letter head**

This is to Certify that M/S .....  
(hereinafter referred to as 'company') having its registered office at .....  
is registered under MSMED Act 2006, (Entrepreneur  
Memorandum No (Part-II) ..... dtd:.....,  
Category: ..... (Micro/Small)). (Copy enclosed).

Further verified from the Books of Accounts that the investment of the company as per the latest audited financial year ..... as per MSMED Act 2006 is as follows:

1. **For Manufacturing Enterprises:** Investment in plant and machinery (i.e. original cost excluding land and building and the items specified by the Ministry of Small Scale Industries vide its notification No.S.O.1722(E) dated October 5, 2006 :  
Rs.....Lacs
2. **For Service Enterprises:** Investment in equipment (original cost excluding land and building and furniture, fittings and other items not directly related to the service rendered or as may be notified under the MSMED Act, 2006:  
Rs.....Lacs

**(Strike off whichever is not applicable)**

The above investment of Rs.....Lacs is within permissible limit of Rs.....Lacs for .....Micro / Small (Strike off which is not applicable) Category under MSMED Act 2006.

Or

The company has been graduated from its original category (Micro/ Small) (Strike off which is not applicable) and the date of graduation of such enterprise from its original category is ..... (dd/mm/yyyy) which is within the period of 3 years from the date of graduation of such enterprise from its original category as notified vide S.O. No. 3322(E) dated 01.11.2013 published in the gazette notification dated 04.11.2013 by Ministry of MSME.

Date:



(Signature)

Name -

Membership number -

Seal of Chartered Accountant

**Annexure-I to Enquiry No.1617-019 Dated 06.05.2016, Due date 27.05.2016**

**Un-Price Bid Format**

Enq Sl. No.	Material Code	Description of material	Material Grade	Drawing No.	TDC No.	Enquiry Qty (Nos.)	Quoted	Unit Basic Price, Rs. per Pc
1	G96110130000	COMPANION FLANGE AS-40276900	S182 F22 C13	42000102769/00	TDC:0:404/15	1250	Yes/No	"Pl. see price bid"
2	#####	FLANGE FORGING	SA 105	42000102723/00	TDC:0:404/15	200	Yes/No	"Pl. see price bid"
Excise Duty rate (mention in % if applicable, mention as <b>NIL</b> if not applicable)							Applicable/Not applicable	
							Extra/Inclusive	
						% if applicable	Pl. clearly mention in % if	
CST (%) / VAT (%)						Extra/Inclusive		
						%		
Validity of offers (As per BHEL terms 90 days validity is required)							Pl. clearly mention	
The above prices are <b>Firm, without any price escalation; are Rs. per pc Basis; and are on FOR Goindwal Sahib basis.</b>								
We accept all terms and conditions of the Tender Enquiry No. 1617-019 Dated 06.05.2016								
Authorised signatory with seal								

**Annexure-II to Enquiry No.1617-019 Dated 06.05.2016, Due date 27.05.2016**

**Price Bid Format**

<b>Enq Sl. No.</b>	<b>Material Code</b>	<b>Description of material</b>	<b>Material Grade</b>	<b>Drawing No.</b>	<b>TDC No.</b>	<b>Enquiry Qty (Nos.)</b>	<b>Unit Basic Price, Rs. per Pc</b>
1	G96110130000	COMPANION FLANGE AS-40276900	S182 F22 Cl3	42000102769/00	TDC:0:404/15	1250	"To be filled by vendor"
2	920121960000	FLANGE FORGING	SA 105	42000102723/00	TDC:0:404/15	200	"To be filled by vendor"

Nothing except prices will be entertained in part-II of tender.

Authorised signatory with seal



**General Contract Conditions (GCC)**  
of  
**MM Tenders**

**Documents submitted with the offer shall be signed and stamped in each page by authorized representative of the bidder.**

**G1. INSTRUCTION TO BIDDER**

Quotations shall be submitted before due date and time. Late offers are liable to be rejected, so please ensure to submit bid well within due date and time. Techno-commercial part will be opened on due date.

**Based on evaluation of techno-commercial offers, Price bids of bidders who qualify from techno-commercial evaluation shall be opened. BHEL may decide to open the Price bid same day at 1700 hrs. If not opened on the same day, all qualifying bidders shall be notified for date of opening of Price bids by email/fax/post/courier.**

Sealed Tenders can be dropped in the tender box labeled as 'Tender box for MM contracts'. This tender box is located at the entrance of Admin block BHEL Goindwal. Fax (01859-222061) / E-Mail (tendermm@bhelivp.in) offers received in time shall be considered only when such offers are complete in all respects.

In case of bulky tender please handover quotation to Sh Harpreet Rai/ DGM/Head-MM or Sh Tajinder Singh/AGM/HR,Civil,MM.

**G2. INSTRUCTION TO BIDDER (In case of E-Procurement)**

The bidder shall submit his response through bid submission to the tender on e-Procurement platform at <https://bheleps.buyjunction.in>

- The bidder would be required to register on the e-procurement market place <https://bheleps.buyjunction.in> and submit their bids online. **Sealed cover bids / e-Mails / FAX / Manual offer will NOT be accepted.**
- The bidder has to keep track of any changes by viewing the addendum / Corrigendum's issued by the Purchaser on time-to- time basis in the E-Procurement platform. The Company calling for tenders shall not be responsible for any claims/problems arising out of this.
- The user should complete all the processes and steps required for bid submission. The successful bid submission can be ascertained once acknowledgement is given by the system through bid submission number after completing all the processes and steps. BHEL and mjunction Services Ltd. will not be responsible for incomplete bid submission by users. Users may also note that the incomplete bids will not be saved by the system and are not available for the Purchaser for processing.

Before uploading scanned documents, the bidders should sign on all the statements, documents, certificates uploaded by him, owning responsibility for their correctness / authenticity. If nothing is mentioned it is assumed that all terms and conditions are acceptable. If supplier is mentioning his rates in units not asked by BHEL, BHEL has the right to reject/accept quotation.

Quotations shall be submitted before due date and time. Techno-commercial part will be opened on due date. BHEL may decide to open price bids of bidders who qualify from techno-commercial evaluation, on the same day at 1700 hrs. If not opened on the same day, all qualifying bidders shall be notified for date of opening of Price bids.

**G3. PRICE BASIS**

- a. CST, VAT & Excise duty + any cess on ED at the rates applicable shall be payable extra against ED Gate Pass valid for CENVAT benefit.
- b. Order of enquiry item sl. No. shall be maintained in the quotation.
- c. The rates quoted shall be firm and fixed. No price variation is proposed and allowed.
- d. Rates quoted should be F.O.R Goindwal basis. If bidder has quoted Ex Works, loading shall be done as per BHEL discretion for tender evaluation.

**Variation in excise duty, sale tax/ vat or any other statutory levies during contractual delivery period shall be to BHEL's account**

*For Kunal*



**General Contract Conditions (GCC)**  
of  
**MM Tenders**

**G4. VALIDITY OF OFFERS:**

The offers shall be kept open for acceptance 'for number of days mentioned in special terms and conditions' from the date of opening of the tender. In case of extension of tender opening date, the validity shall be suitably revised.

**G5. SCOPE OF SUPPLY**

Material shall be supplied as per the applicable latest Technical Delivery Conditions (TDC)/ Material Standard requirements/BPS/Drawing and other requirement as given in the Tender Enquiry. National & International material Standards shall have to be arranged by vendors themselves.

**G6. REPLACEMENT OF REJECTION:**

If the material is rejected due to defective workmanship during inspection or at the time of actual use, within the guarantee period (i.e. as per clause 13), the rejected material shall be replaced by the supplier. Corresponding quantity shall be treated as unsupplied against respective purchase order till replacement is received at BHEL. If the material is found defective and rejected during use for which payment has already been released the rejected quantity shall be supplied free of cost by the vendor within a month of intimation of the rejection by BHEL.

Lifting of rejected material is under Supplier's scope. BHEL will inform related invoice, qty etc to supplier. Supplier is expected to give the plan to lift and advance intimation when visiting to lift the material. Material should be lifted within one month from date of intimation. After one month BHEL will not be responsible for rejected material. BHEL may decide to send the rejected material on To Pay basis to supplier. Any leniency/ unresponsiveness/delay on part of supplier may lead to appropriate action by BHEL. Any request to postpone in written may be considered but replacement should not be linked with lifting of material.

**G7. SUPPLIED MATERIAL ADJUSTMENT:**

Item/s pending in previous PO has to be billed in previous PO only. Otherwise BHEL will be free to adjust the supplies in previous PO. Any implication of Excise, VAT etc will be on supplier's account. For this it is desirable to reconcile the pending PO statement every month/frequently. BHEL will give pending PO statement every month. This can also be viewed at Portal (<http://vis.bheltry.co.in/mm/index.jsp>).

**G8. DELIVERY SCHEDULE:**

Supplies shall be affected and completed as per schedule mentioned in special terms and conditions. **Further, BHEL may release delivery schedule from time to time based upon our requirement with mutual understanding.** Vendor shall be required to complete the order as per the BHEL schedule requested.

**G9. ACCESS TO MANUFACTURING PREMISES:**

While Purchase Orders placed on the vendor are under execution, authorized representatives of BHEL shall be allowed free access to the manufacturing facilities for the purpose of inspection or monitoring the progress of purchase orders. This access will also be extended to representatives of BHEL's customers accompanying the authorized representative/s of BHEL (which shall be intimated in advance), if our contractual requirements with our customers call for the same.

**G10. TERMS OF PAYMENT:**

- a. Due payment against supplies received shall be due after 30 days of receipt and acceptance of material and shall be paid within next 15 days period. In case of any deviation from standard payment term mentioned, BHEL at it's discretion may load on the item price at "Base rate of SBI (as applicable on the date of bid opening; Techno-commercial bid opening) + 6% shall be considered for loading for the period of relaxation sought by bidders.
- b. Documents to be submitted (if applicable)
  - i. Commercial invoice (in duplicate)

*Byrl Kumar*



**General Contract Conditions (GCC)**  
of  
**MM Tenders**

- ii. Excise invoice (in duplicate) valid for claiming CENVAT credit
  - iii. Original VAT invoice valid for claiming input tax credit,
  - iv. Transporter copy along with material/consignment.
  - v. Material Test Certificates (MTC) and
  - vi. Compliance Certificate.
- c. Above documents should include your Registration numbers such as ECC no, PAN no, CST no, TIN/ VAT nos. etc.
- d. If excise claim document is not received within time for claiming excise benefit as per restriction in availment of CENVAT Credit within 12 months of date of Invoice (Amendments in Union Budget 2015), the implication of this will be paid by supplier.
- e. It is mandatory to mention proper material codes in the invoices and separate invoices to be raised for different POs.
- f. ***BHEL releases payment through EFT mode ONLY. Necessary details may please be submitted by filling required format before release of payment.***

**G11. INSPECTION:**

- a. All required tests as called in referred material standard/BHEL/TDC/drawing etc shall be carried out by vendor at no extra cost. **BHEL may decide to inspect itself/arrange third party at vendors' works itself as and when necessary with prior intimation to the vendor.** No additional charges shall be claimed for such inspections.
- b. Third party inspection charges will be borne by BHEL. Moreover all required infrastructure (testing, tools etc) have to be arranged by supplier.
- c. **Vendor will give inspection call sufficiently in advance considering the delivery period stipulated in the purchase order.**
- d. Material Test Certificates (MTC), Inspection reports and Compliance/Guarantee Certificate are to be provided along with the supplies.
- e. Latest applicable revisions of standards/procedures to be referred. International/National standards are to be arranged by vendor.
- f. Any inspection carried out before supply by vendor/incoming stage at BHEL not withstanding, if any defect/non-conformity is noted during processing, the same shall be attended/replaced by vendor at no extra cost.
- g. Necessary tooling including thread gauges etc have to be arranged by vendor. Only in exceptional cases, based on BHEL discretions item/nature, BHEL may consider request to provide gauges if available with BHEL. But in no case this shall be linked with delivery of material.

**G12. PREFERENCES FOR MSE's:**

Preferences as mentioned in "Public Procurement Policy for Micro and Small Enterprises (MSEs) Order, 2012" shall be given to Micro and Small enterprises.

Main points which are mentioned in the above order are as follows:

- 20% Procurement of the tender value shall be made from MSE (Micro, Small Enterprises) firms.
- 4% from the above mentioned 20% procurement quantity shall be procured from MSE's owned by SC /ST's. Failure to participate by any MSE owned by SC/ST's this 4% quantity shall be procured from other MSEs.
- EMD shall be exempted for MSE's. All these benefits are subject to production of all statutory documents
- In tender, participating Micro and Small Enterprises quoting price within price band of L1+15 per cent shall also be allowed to supply a portion of requirement by bringing down their price to L1 price in a situation where L1 price is from someone other than a Micro and Small Enterprise and such Micro and Small Enterprise shall be allowed to supply up to 20 per cent of total tendered value. In case of more



**General Contract Conditions (GCC)**  
of  
**MM Tenders**

than one such Micro and Small Enterprise, the supply shall be shared proportionately (to tendered quantity).

“MSE suppliers can avail the intended benefits only if they submit along with the offer, attested copies of either EM II certificate having deemed validity (five years from the date of issue of acknowledgement in EM II) or valid NSIC certificate or EM II certificate along with attested copy of a CA certificate (Format enclosed at Annexure -1 where deemed validity of EM II certificate of five years has expired) applicable for the relevant financial year (latest audited). Date to be reckoned for determining the deemed validity will be the date of bid opening (Part 1 in case of two part bid). Non submission of such documents will lead to consideration of their bid at par with other bidders. No benefit shall be applicable for this enquiry if any deficiency in the above required documents is not submitted before price bid opening. If the tender is to be submitted through e-procurement portal, then the above required documents are to be uploaded on the portal. Documents should be notarized or attested by a Gazetted officer.”

**G13. GUARANTEE/WARRANTEE:**

Vendor shall give a guarantee of 18 months from the date of dispatch or 12 months from date of receipt, against manufacturing defects, whichever is earlier. In case of non-acceptance of this term bid will be rejected.

**G14. PENALTY FOR LATE DELIVERY:**

‘Time is the essence of the contract’. As such, delivery of goods specified in the Purchase Orders released under the scope of this contract shall be made within the time limit prescribed therein. Penalty for late delivery will be applicable @ 0.5% per week or part thereof subject to a maximum of 10.0 %.

If any vendor does not accept LD ½% of the supply for each week of delay subject to a maximum of 5%, their offer is likely to be rejected by BHEL and the price bid shall not be opened. Bidders accepting for 10% LD shall not be loaded on account of LD. However bidders who offer any other % LD [between 5% to 10%] shall be loaded @ % deviation from 10% and their accepted %.e.g. If a bidder accepts for a max of 7% LD only, their offer would be loaded @ 3% (10 - 7 = 3).

BHEL reserves the right to receive or not receive the material after the due date of PO.

**G15. RISK PURCHASE:**

BHEL shall be entitled to terminate the contract/pending POs at any stage and to purchase elsewhere at the risk and cost of the vendor, either the whole of the goods or any part thereof which the supplier has failed to deliver or dispatch within the time stipulated as aforesaid. Vendor shall be liable for the losses, which BHEL may sustain by way of such risk purchase.

**G16. SUB-CONTRACT:**

The purchase order or any part thereof shall not be sub-contracted, assigned or otherwise transferred without previously obtaining the BHEL's consent in writing.

**G17. FORCE MAJEURE:**

If at any time during the continuance of the contract, the performance in which or in any part by either party of any obligations under the contract are prevented or delayed by reason of any war, hostilities, acts of public enemy, civil commotion, sabotage, fires, explosions, epidemics, quarantine restrictions, or acts of God (hereinafter referred to “an events” then provided the notice of happening of any such event is given by either party to the other within 21 days of the occurrence thereof, neither party shall by reason of such

*for Kunal*



**General Contract Conditions (GCC)**  
of  
**MM Tenders**

event be entitled to terminate the contract nor shall either party have any claim for damages against the other in respect of such non-performance and delay in performance and delivery under the contract shall be resumed as soon as practicable after such event has come to an end or ceased to exist. If the performance in whole or part of any obligation under the contract is prevented or delayed by reason of any such event, claims of extension of time shall be granted for periods considered reasonable by BHEL subject to prior notification by the vendor to BHEL of the particulars of the event and supply to BHEL, if required, of any supporting evidence. Any waiver of time in respect of partial installment shall not be deemed a waiver of time in respect of remaining deliveries.

**G18. DISPUTES:**

In the event of any dispute and/or difference arising between the Vendor and BHEL as to interpretation and/or execution of the contract and/or the respective rights and liabilities of the parties, such disputes and/or differences shall be referred to the sole arbitrator nominated by BHEL. The provisions of the Indian Arbitration Act and the rules there under shall apply to such arbitration. The award passed by the arbitrator shall be final and conclusively binding on all the parties.

**G19. JURISDICTION:**

The court of the place from where the purchase order is issued during the contractual period shall alone have jurisdiction to decide any dispute arising out of or in connection with the purchase order.

**G20. CLARIFICATIONS**

The correspondence exchanged against the tender from both tenderer and BHEL through email/e-procurement are considered as valid document legally though it is not signed. It is treated as valid confirmations made on behalf of the respective company and very much comes under the legal ambit of the business transaction and hence it is binding on both the parties to the business. Any transaction pertaining to the tender from both the parties of business done round the clock irrespective of the office or business hours of the companies, are valid legally and binding on both the parties. This applies to the extent only in such cases where deadline time for transaction is not specifically declared by either or both the parties to the business.

**G21. LOI(Letter of Intent)**

BHEL may issue LOI prior to the PO for any reason whatsoever. The LOI in such cases is to be treated as PO for all practical purposes and all the Terms & Conditions of the tender shall be applicable from the date of issue of LOI.

**G22. WORDS AND FIGURES**

- a. If, in the price structure quoted for the required goods/ services/ works, there is discrepancy between the unit price and the total price (which is obtained by multiplying the unit price by the quantity}, the unit price shall prevail and the total price corrected accordingly, unless in the opinion of the purchaser there is an obvious misplacement of the decimal point in the unit price, in which case the total price as quoted shall govern and the unit price corrected accordingly.
- b. If there is an error in a total corresponding to the addition or subtraction of subtotals, the subtotals shall prevail and the total shall be corrected; and
- c. If there is a discrepancy between words and figures, the amount in words shall prevail, unless the amount expressed in words is related to an arithmetic error, in which case the amount in figures shall prevail subject of (a) and (b) above.
- d. If there is such discrepancy in an offer, the same shall be conveyed to the bidder with target date upto which the bidder has to send his acceptance on the above lines and if the bidder does not agree to the decision of the purchaser, the bid is liable to be ignored.

*For General*



**General Contract Conditions (GCC)**  
of  
**MM Tenders**

**G23. GENERAL:**

- a) BHEL will not be bound by any power of attorney granted by the vendors or by changes in the composition of the firm made subsequent to the execution of the contract. They may, however, recognize such power of attorney and changes after obtaining proper legal advice, the cost of which will be chargeable to the vendor concerned.
- b) BHEL reserves the right to extend the due date of opening, which shall be informed. Validity of offer shall be deemed to be revised accordingly.
- c) BHEL reserves the right to accept or reject any part or whole of the tender of a bidder by assigning a valid reason thereof. BHEL reserves the right to cancel the tender without assigning any reason thereof and without any obligation before any commitment.
- d) If possible, please submit soft copy of price quotation [copied on a blank CD of standard make] put in the sealed offer.
- e) Acceptance of all terms and conditions, in the form of signed copy of T&C or confirmation separately written, shall be submitted along with quotation. If nothing is mentioned, it shall be concluded that terms and conditions are acceptable.
- f) BHEL may increase/decrease item/s based on BHEL requirement before price bid opening. Suitable price implication may be asked from suppliers.
- g) BHEL may drop item/items from tender at any stage of tender before placing PO. BHEL may also delete PO with consent with supplier within delivery date of PO.
- h) After releasing PO, it is assumed that supplier has accepted PO if we do not receive acknowledgement from supplier within 5 days of date of PO.
- i) Any term is special tender terms and conditions will supersede the GCC.
- j) If advance tax is applicable at Punjab border. Supplier has to deposit this advance tax by himself which will be reimbursed on submission of documentary proofs (Copy of entry tax receipt/online transfer details duly verified).
- k) BHEL reserves the right to negotiate with L1 bidder/s.

**G24. BANNED FIRMS:**

The offers of the bidders who are on the banned list as also the offer of the bidders, who engage in the services of the banned firms, shall be rejected. The list of banned firms is available on BHEL website [www.bhel.com](http://www.bhel.com).

**G25. DISCLAIMER CLAUSE: (Only for E procurement)**

Neither the Organization (Bharat Heavy Electricals Ltd.) nor the service provider (mjunction Services Ltd.) is responsible for any failure of submission of bids due to failure of internet or other connectivity problems or reasons thereof.

**G26. FRAUD PREVENTION POLICY:**

The Bidder along with its associate/collaborators/sub-contractors/sub-vendors/consultants/service providers shall strictly adhere to BHEL Fraud Prevention Policy displayed on BHEL website <http://www.bhel.com> and shall immediately bring to the notice of BHEL management about any fraud or suspected fraud as soon as it comes to their notice.

**G27. REVERSE AUCTION:**

"BHEL reserves the right to go for Reverse Auction (RA) instead of opening the sealed envelope price bid, submitted by the bidder. This will be decided after techno-commercial evaluation. All bidders to give their acceptance for participation in RA. Non-acceptance to participate in RA may result in non-consideration of their bids, in case BHEL decides to go for RA.

In case BHEL decides to go for Reverse Auction, only those bidders who have given their acceptance to participate in RA will be allowed to participate in the Reverse Auction. Those bidders who have given their acceptance to participate in Reverse Auction will have to necessarily submit "online sealed bid" in



**General Contract Conditions (GCC)**  
of  
**MM Tenders**

the Reverse Auction. Non- submission of „online sealed bid“ by the bidder will be considered as tampering of the tender process and will invite action by BHEL as per extant guidelines in vogue.”

**Terms & Conditions of Reverse Auction**

Against this enquiry for the subject item/ system with detailed scope of supply as per enquiry specifications, BHEL may resort to “REVERSE AUCTION PROCEDURE” i.e., ON LINE BIDDING (THROUGH A SERVICE PROVIDER). The philosophy followed for reverse auction shall be English Reverse (No ties).

- a. For the proposed reverse auction, technically and commercially acceptable bidders only shall be eligible to participate.
- b. Those bidders who have given their acceptance for Reverse Auction (quoted against this tender enquiry) will have to necessarily submit “online sealed bid” in the Reverse Auction. Non-submission of „online sealed bid“ by the bidder for any of the eligible items for which techno- commercially qualified, will be considered as tampering of the tender process and will invite action by BHEL as per extant guidelines in vogue.
- c. BHEL will engage the services of a service provider who will provide all necessary training and assistance before commencement of on line bidding on internet.
- d. In case of reverse auction, BHEL will inform the bidders the details of Service Provider to enable them to contact & get trained.
- e. Business rules like event date, time, bid decrement, extension etc. also will be communicated through service provider for compliance.
- f. Bidders have to fax the Compliance form (annexure IV) before start of Reverse auction. Without this, the bidder will not be eligible to participate in the event.
- g. In line with the NIT terms, BHEL will provide the calculation sheet (e.g., EXCEL sheet) which will help to arrive at “Total Cost to BHEL” like Packing & forwarding charges, Taxes and Duties, Freight charges, Insurance, Service Tax for Services and loading factors (for non- compliance to BHEL standard Commercial terms & conditions) for each of the bidder to enable them to fill-in the price and keep it ready for keying in during the Auction.
- h. Reverse auction will be conducted on scheduled date & time.
- i. At the end of Reverse Auction event, the lowest bidder value will be known on auction portal.
- j. The lowest bidder has to fax/e-mail the duly signed and filled-in prescribed format for price breakup including that of line items, if required, (Annexure VII) as provided on case-to-case basis to Service provider within two working days of Auction without fail.
- k. In case BHEL decides not to go for Reverse Auction procedure for this tender enquiry, the Price bids and price impacts, if any, already submitted and available with BHEL shall be opened as per BHEL’s standard practice.
- l. Bidders shall be required to read the “Terms and Conditions” section of the auctions site of Service provider, using the Login IDs and passwords given to them by the service provider before reverse auction event. Bidders should acquaint themselves of the “Business Rules of Reverse Auction”, which will be communicated before the Reverse Auction.
- m. If the Bidder or any of his representatives are found to be involved in Price manipulation/ cartel formation of any kind, directly or indirectly by communicating with other bidders, action *as per extant BHEL guidelines*, shall be initiated by BHEL and the results of the RA scrapped/ aborted.
- n. The Bidder shall not divulge either his Bids or any other exclusive details of BHEL to any other party.
- o. In case BHEL decides to go for reverse auction, the H1 bidder (whose quote is highest in online sealed bid) may not be allowed to participate in further RA process.**

An abridged version of ‘Common Guidelines for conducting Reverse Auction’, has now been uploaded at ‘Supplier Registration’ page & ‘Tender Notifications’ page on BHEL website ([www.bhel.com](http://www.bhel.com)). Supplier can visit this page for more details on RA process.

*Handwritten signature*



BHEL GOINDWAL

**SPECIAL TERMS AND CONDITIONS FOR**  
**(Tender Enquiry No. 1617-019 Dated 06.05.2016 Due date 27.05.2016)**  
**ITEM: Machined Forging of Companion Flange**

<b>Tender Enquiry No</b>	<b>1617-019</b>
<b>Enquiry date</b>	<b>06.05.2016</b>
<b>Last time and date of tender submission</b>	<b>14:00 Hrs 27.05.2016</b>
<b>Tender opening time and date</b>	<b>15:30 Hrs 27.05.2016</b>
<b>Quotation Parts</b>	<b><i>Two-part</i></b>
<b>Item Description</b>	<b><i>Machined Forging of Companion Flange</i></b>
<b>Delivery schedule (In days)</b>	<b><i>Within 03 months</i></b>
<b>Validity of offer (In days)</b>	<b><i>90</i></b>
<b>Documents required along with supply of material</b>	<b><i>Applicable</i></b>
<b>Test Certificate</b>	<b><i>Required</i></b>

## **PREQUALIFICATION TERMS**

### **P1. Technical**

1. Bidders should primarily be engaged in manufacturing and supply of material grade as required by BHEL in Companion Flange forging. Vendor has to provide any customer's PO copy for these material grades. PO date should be 01.01.2014 or onward and cumulative value of POs should minimum 20.00 Lacs.
2. Suppliers not engaged in manufacturing of forgings will not be considered. Vendor has to give any one proof that he is manufacturer e.g copy of ECC (Excise control Code) Number/MSME certificate/VAT Registration number (If applicable), List of forging facilities etc.
3. Machining Facility (for proof machining) can be in-house or outsourced. In case of in-house machining facility – details to be provided. In case of outsourcing of Machining facilities BHEL intends to satisfy itself that party has suitable arrangement for machining. A document for the tie-up/MOU/Purchase order on machining house(s) has to be provided with the details of machining facility available with the attached machining house.
4. The forgings are IBR items. Therefore vendor should be having either well known forge certificate or should do witness forging. The vendor should submit certificate of well-known forge or undertaking that he will do witness forging.

BHEL reserves the right to accept/reject any offer based on evaluation of bidder's capability. For verification of data presented for pre-qualification bid, BHEL may decide to visit the bidder(s) works.

### **P2. Earnest Money Deposit (EMD)**

The bidder shall be required to deposit earnest money of Rs. 10,000/- (Rupees ten thousand only) in Cash / Demand Draft/Pay Order only payable at Punjab National Bank/State Bank of India/HDFC Bank/Union Bank of India/Allahabad Bank/Punjab & Sind Bank at Goindwal Sahib, Distt. Tarn Taran or through Demand Draft of any other bank Payable at Amritsar.

*Ravi Kumar*



**SPECIAL TERMS AND CONDITIONS FOR**  
**(Tender Enquiry No. 1617-019 Dated 06.05.2016 Due date 27.05.2016)**  
**ITEM: Machined Forging of Companion Flange**

An envelope containing EMD shall be attached clearly marked "EMD" and reference to Enquiry no. Part I bids of those bidders only shall be considered who have attached EMD envelope.

Following shall be exempted from submitting EMD:-

1. PSUs of Central Government/State Governments (proper evidence had to be submitted).
2. Micro and Small Enterprises (documents required as per as per tender terms G.12 of General Contract Conditions).

EMD given by all unsuccessful bidders shall be refunded normally within 15 days of placing PO/Contract to successful bidder. EMD by the Bidder will be forfeited as per Tender Documents if, the successful bidder/vendor refuses to accept or acknowledge the Order after award of the same on him and/or withdraws his bid and /or unilaterally changes the offer and/or any of its terms & conditions within the validity period. EMD shall not carry any interest.

The EMD of successful bidder shall be returned after completion of purchase order.

## SPECIAL TERMS

### **S1. QUOTATION SUBMISSION**

Sealed tenders in two part bids are invited from manufacturers for supply forging as per details given in un-priced bid format (Annexure-I). Part-I contains Pre-qualification & Techno-commercial bid and Part-II contains Price bid. Clause No.G1 of GCC of MM Tender is to be followed for submitting the quotation.

Bid	Details	Required
Part-I	PART-I: "Pre-qualification cum Techno-Commercial Bid" Tender Enquiry no. 1617-019 Dated 06.05.2016 Due date of opening: <u>27.05.2016</u>	<ol style="list-style-type: none"><li>1. Acceptance of all terms and conditions.</li><li>2. EMD/Proof of exemption</li><li>3. Proof of manufacturer</li><li>4. PO copies</li><li>5. Machining facility details</li><li>6. IBR well known forge certificate/undertaking for witness forging</li></ol>
Part-II	PART-II: "Price Bid" Tender Enquiry no. 1617-019 Dated 06.05.2016	Price bid

It is to be noted that all procurement through open tender will be done through e-procurement only in near future. Therefore all foreign and indigenous vendors participating through open tenders have to buy class-III DSC immediately issued by the certifying authorities in India.

*Handwritten signature*



BHEL GOINDWAL

**SPECIAL TERMS AND CONDITIONS FOR  
(Tender Enquiry No. 1617-019 Dated 06.05.2016 Due date 27.05.2016)  
ITEM: Machined Forging of Companion Flange**

**S2. LOADING CRITERIA CUM COUNTER OFFER**

BHEL reserves the right to negotiate with L1 vendor or re-float the tender in case the quoted prices are not acceptable.

**For Item No.1 - COMPANION FLANGE AS-40276900:**

BHEL will give counter-offer to vendors other than L1, in order to have broader vendors base for ensuring timely delivery for the item. Following directions shall be followed when allotting the tender quantities for Item No.1.

1. Tender quantity shall be divided in the proportion 60:20:20 (60% for L1, 20% for L2 and 20% for MSE's) in case the L1 vendor is not a MSE subject to following conditions:

I. L2 acceptance of L1 rates.

II. In tender, participating Micro and Small Enterprises quoting price within price band of L1+15 per cent shall also be offered 20% quantity of tender quantity at L1 price in a situation where L1 price is from someone other than a Micro and Small Enterprise. In case of more than one such Micro and Small Enterprise, the supply shall be shared equally. If there are more than one MSE in the price band of L1+ 15% to whom the offer has been sent and some of them reject the offer then the remaining quantity shall be distributed equally to the MSEs accepting L1 prices.

III. 20% from the 20% quantity (i.e. 4% of the tender quantity) offered to the MSE's shall be reserved for MSE's owned by SC/STs. In event of failure of such Micro and Small Enterprises to participate in tender process or meet tender requirements and L1 price, 4 per cent quantity for Micro and Small Enterprises owned by SC/ST entrepreneurs shall be met from other Micro and Small Enterprises.

IV. In case any MSE vendor does not accept the counter offer, the above mentioned 20% quantity shall be offered to L2.

V. If there is no MSE in the Price band of L1+15% then the 20% quantity shall be offered to L2 vendor.

VI. If other suppliers (other than L1) are not under MSE then 60% qty shall be given to L1 and 40% qty shall be offered to L2 supplier.

2. In case if the L1 vendor is MSE then quantity shall be provided as 60 % for L1, 36% for L2 and 4% tender quantity shall be offered to the MSEs owned by SC/ST's in the price band of L1+15%. In event of failure of such Micro and Small Enterprises to participate in tender process or meet tender requirements and L1 price, 4 per cent sub-target for procurement earmarked for Micro and Small Enterprises owned by SC/ST entrepreneurs shall be met from L2 vendor.

3. In case the L1 vendor is a MSE owned by a SC/ST then the 60% qty shall be given to L1 and 40% qty shall be offered to L2 supplier.

All above offered qty are subject to acceptance of L1 rates.

In case of non- acceptance of counter offer by any vendor after above applicable provisions the whole quantity shall be given to L1 vendor.

This ratio can be altered in case of any failure on part of L1 regarding delivery commitment/quantity/quality of material.

**For Item No.2 – FLANGE FORGING:**

BHEL will not give counter-offer to vendors for this tender except MSE benefits mention in clause no.G12 of GCC of MM Tenders.

Note: All above mentioned preferences shall be given to MSEs and SC/STs only on the submission of documentary evidence.

**BHEL will not give counter offer to highest bidder in any case.**

If there are more than one L1 bidders, quantity shall be equally divided, except MSE portion.

*For the matter*



**SPECIAL TERMS AND CONDITIONS FOR  
(Tender Enquiry No. 1617-019 Dated 06.05.2016 Due date 27.05.2016)  
ITEM: Machined Forging of Companion Flange**

**S3. ADVANCE TAX**

Advance tax is applicable as on date on these castings at Punjab border. Supplier has to deposit this advance tax by himself which will be reimbursed on submission of documentary proofs (Copy of entry tax receipt/online transfer details duly verified). Present rate of advance tax is 3.50%.

**S4. FRAUD PREVENTION POLICY:**

The Bidder along with its associate/collaborators/sub-contractors/sub-vendors/consultants/service providers shall strictly adhere to BHEL Fraud Prevention Policy displayed on BHEL website <http://www.bhel.com> and shall immediately bring to the notice of BHEL management about any fraud or suspected fraud as soon as it comes to their notice.

**S5.** An abridged version of 'Common Guidelines for conducting Reverse Auction', has now been uploaded at 'Supplier Registration' page & 'Tender Notifications' page on BHEL website ([www.bhel.com](http://www.bhel.com)). Supplier can visit this page for more details on RA process.

*Best final*



**Product: Carbon, Alloy & Stainless Steel Forgings (Boilers And Valves)**

#### Revision Record:

- Rev 09: New materials F23, F91 & F92 requirements added in Cl.1.0, Cl.2.0, and Cl.4.0 to Cl.6.0. CE marking certification clarity included in Cl.10.
- Rev 10: Cl 1:F6a Class 2 added, Code case corrected. Cl 2: Steel makers names removed and requirement for creep testing added as per IBR Reg 4, Cl 4: Tempering temperature and soaking time modified for SA 182 F91, F92 & F23. Cl 4 & 10: Photomicrograph requirement added for F91 & F92 forgings, Cl 2, 6 & 10: modified for SS, Cl 5: Bend test Clarified, Cl 6: Wet MPI added.
- Rev 11: Cl 2 Pt 3, 4, 5 modified. Cl 6 – Wet MPI for CS, AS added, Cl 10.1 – IBR Forms indicated
- Rev 12: Cl 1, 2, 4, 6 and 7 – requirements for grades SA 182 F1, SA 336 F1, F12, F22 Cl 3 and F91 added (for Neyveli Project). Creep test criteria in-line with BHEL R&D included. Cl 2 Pt 8 modified. Cl 6 Pt 1 – SA388 changed to ASTM A 388 based on ASME Sec II Ed 2013.
- Rev 13: Dt: 17/11/2014: Cl 2 Cl 4 Cl 10 Cl 12 modified.
- Rev 14: Dt: 06/10/2015: Cl.4.3, 5.2, 5.8, 10.1.b.9 added; Cl 1.0, 2.1, 2.2, 2.3, 4.1, 4.2, 5.3, 6.2, 9.0, 10 modified.
- Rev 15: Dt: 23/12/2015: Cl 1, 2, 3, 5, 6, 7, 10, 11 & 12 modified.

## 1. MATERIAL

Specification: ASME (Latest as on the date of Enquiry/Purchase Order, whichever is earlier): (ASTM also applicable for non-pressure parts/Valves)

Carbon Steel (CS)	:	SA 105, SA 350 LF 2
Alloy Steel (AS)	:	SA 182 F12 Class 2, F22 Class 3, SA 182 F23 (Code case: 2199), SA 182 F91 & SA182 F92 (Code Case: 2179), SA 182 F1, SA 336 F1, SA 336 F12, SA 336 F22 Cl 3, SA 336 F91
Stainless Steel (SS)	:	SA 182 F6a Class 2, F6a Class 3, SA 182 Gr. F 304, 304L, 316, 316L, 316H, 321, 321H, 347 & 347H; AISI 410 for TOA Gland and bushings.
Additional Requirement	:	As listed below (supplementary to Specification)
Size and Qty	:	As per Purchase order & Drawing.

**For API-6D 24<sup>th</sup> Edition 2014 materials for sour service:** Materials for pressure-containing and pressure-controlling parts shall meet the requirements of NACE MR0175 Ed 2009.

## 2. CHEMICAL COMPOSITION & PROCESS

- 1) Melting: fully killed.

Product analysis per heat: CS: C ≤ 0.25% , AS: SA182 F23: Si: 0.25-0.50% & Cu: 0.25max  
SA182 F92: Si: 0.10-0.50%, Ni: 0.30 max & Cu: 0.25% max

**Additional requirements for API-6D materials (in Product analysis):**

CS: Carbon: 0.23% max.

Sulfur: 0.020% max, Phosphorus: 0.025% max

Carbon Equivalent (CE): 0.43% max.

Carbon Equivalent formula:  $\%C + (\%Mn/6) + (\%Cr + \%Mo + \%V)/5 + (\%Ni + \%Cu)/15$ .

SS: The carbon content of austenitic stainless steel welding ends shall not exceed 0.03 % by mass, except for stabilized material in which case a carbon content of up to 0.08 % by mass is permissible.

- 2) Raw material Steel for IBR forging items to be inspected at Mill & test certificate countersigned by IBR approved inspecting authority, if the mill is not approved under IBR as well known steel maker.
- 3) Forging: Hot working to ensure uniformity of structure & strength with reduction ratio in area 4:1 min from ingot to final forging, close to final size & shape. Flow lines to be parallel to axis of openings. Forged Items ordered to this TDC shall be forged to the nearest shape before machining to final dimensions as per respective drawing.
- 4) Blooms / Billets used for forgings (Side Length, Dia ≥ 50mm) shall be UT tested. For Acceptance Norm refer Cl.6.0. For finished bars this can be done at Final stage.
- 5) SS: All raw materials used in steel making including incoming scrap shall be checked by supplier to ensure freedom from radioactivity.
- 6) *Tolerance for chemistry shall be as per the above applicable material specifications/ standards.*

## 3. DIMENSIONS AND TOLERANCES

Tolerances as per Drawing. Untoleranced dimensions for valve components as per VL:STDC:023 Rev: 00.

## 4. HEAT TREATMENT (HT)

- 1) Heat treatment shall be as per applicable drawing. Unless otherwise specified, the following heat treatment shall be following:
- CS: SA 105: Normalised, SA 350 LF 2: Normalised at 880-900 °C & Tempered at 620-640 °C  
AS: Normalised and Tempered.  
For SA 182 F91, F92 & F23, SA336 F91 Normalising temperature : 1050-1080°C & Tempering temperature : 750-780°C.  
SS: As per material specification.  
AISI 410: Supply in Quenched & Tempered condition as below.



**Product: Carbon, Alloy & Stainless Steel Forgings (Boilers And Valves)**

Quenching at 955-1010°C in air or water or oil or Polymer. Soaking 30 mts/inch maximum thk. Tempering at 663°C.min. Soaking :60 mts/inch maximum thickness and air cool.

- 2) Photomicrograph test for F91 & F92 forgings - one per heat treatment lot per size and shall be reported in test certificate. **Acceptance** – The material shall be free from any micro fissures. Microstructure shall show lathe tempered martensite and also to be examined for grain growth. Photomicrograph with 400x (Min) magnification along with Photomicrograph report to be provided. The actual magnification and result of actual microstructure shall be certified/indicated.
- 3) **HT Equipment qualification for API-6D materials:** As per Annex F of API 6D 24<sup>th</sup> Edition. Materials shall be heat treated in calibrated furnaces (HT Equipment) and furnaces shall be recalibrated at a frequency not longer than 12 months from the last calibration.

**5. MECHANICAL TESTS**

- 1) Extent of test: for each size/heat/HT batch from sample product or identical test coupon.
- 2) Tensile test: The test specimens shall be removed from a test coupon (TC) after the final heat-treatment cycle. Perform tensile tests at room temperature in accordance with the procedures specified in ASTM A370-2014. Perform a minimum of one tensile test. All yield strengths shall be determined using 0.2 % offset method. The results of the tensile test(s) shall satisfy the applicable material specification requirements.

If the results of the tensile test(s) do not satisfy the applicable requirements, two additional tests on two additional test specimens (removed from the same TC with no additional heat treatment) may be performed in an effort to qualify the material. The results of each of these tests shall satisfy the applicable requirements.

- 3) Additional requirements for SA182 F23, F91 & F92:  
 F91: Yield: (0.2% offset): Min 450 MPa; Tensile: Min 630 MPa, Max 850 MPa; Hardness(HBW): Min 195, Max 248  
 F92: Tensile: Min 630 MPa, Max 850 MPa; Hardness(HBW): Min 191, Max 250  
 F23: Tensile: Min 510 MPa, Max 730 MPa; Hardness(HBW): Min 150, Max 220
- 4) AISI 410: Hardness 197-235 HBW. No other mechanical test required.

Additional requirements of tests: (Other than AISI 410 Only)

- 5) **Bend test: Acceptance as per IBR**  
 CS: Sample 19mm.Thick(t) x 25.4mm width to be bent 180 deg. around mandrel of radius 6.35 mm.  
 AS, SS: Sample 19mm.Thick(t) x 25.4mm width to be bent 180 deg. Around mandrel of radius =1.5 x t
- 6) **Impact test for QCNR Valves & CRHNR Valves:** CS, AS and SS: 1 / HT batch. As per ASTM A 370-2014, 2mm Charpy-U notch, at Room temperature. Acceptance: Avg of 3specimens: 36J, Single Min: 24J
- 7) **CE-marking items** Charpy- V impact test at 20 deg.C as per ASTM A 370-2014, Acceptance : Avg : 40 joules, Min. single value: 27 joules.
- 8) **Impact testing for API 6D items:** Carbon, alloy and stainless steel (except austenitic grades) for pressure-containing parts in valves with a specified design temperature below -29°C shall be impact-tested. A minimum of one impact test, comprised of a set of three specimens, shall be performed on a representative test bar of each heat of the material in the final heat-treated condition. If a test fails, then a retest of three additional specimens removed from the same TC, with no additional heat treatment, may be made, each of which shall exhibit an impact value equal to or exceeding the required average value.

**Carbon and Alloy steels:** Charpy- V impact test as per ASTM A 370-2014, Test Temperature: As per specification; Acceptance criteria: As per below table:

**Minimum V-notch Impact Requirements (Full-size Specimen)**

Minimum Tensile Strength (MPa)	Average of Three Specimens (Joules)	Single Specimen (Joules)
≤ 586	20	16
> 586 to 689	27	21
> 689	34	26

**6. NON DESTRUCTIVE TEST**

- 1) Extent of test: for each product. Stage of test : After heat treatment.
- 2) **UT:** As per ASTM A388-2014 - All finished forgings of dia/wall thickness ≥50mm; All Body & yoke of special class valves & all forgings of SA 182 F91, F92 & F23, SA 336 F91. **Acceptance:** ASME Sec.VIII Div. 2 Cl.3.3.4.
- 3) **MPI for CS & AS:** 100% : As per ASTM A275-2015. Dry MPI/ Wet MPI : CS, AS (other than SA182 F91, F92, F23, SA 336 F91) : all sizes Wet MPI : SA 182 F91, F92, F23; SA 336 F91: all sizes. **Acceptance:** ASME B16.34-2013 Appendix II .Linear Indications like cracks, folds & other injurious defects are unacceptable.
- 4) **LPI for SS:** 100%: ASTM E165-2012, No linear indications acceptable.
- 5) SS: Finished forgings shall be checked for radioactive contamination and reported. Survey meter shall be used to measure at 5 cm near the surface. Acceptance limits: Shall be less than 0.1 milli Rontgen (MR) per hr or 1 micro Sievert per hr.



**Product: Carbon, Alloy & Stainless Steel Forgings (Boilers And Valves)**

**7. WORKMANSHIP AND FINISH**

Forged items to spec SA336 shall be machined in the inside surface as it is meant for steam application. Items to be proof machined as per drawing or shot blasted for CS/AS, Pickled & passivated as per ASTM A 380-2013 for SS, & be free from scales & defects like laps, seams, folds, cracks, etc. Machined items (except SS) to be coated with a layer of transparent rust preventive before despatch.

**8. REPAIR**

Repairs by fusion welding are prohibited. Surface defects can be removed by mechanical means and defective areas smoothly dressed up with the adjacent surface. Minimum thickness after repair to meet drawing / Specification.

**9. MARKING AND PACKING**

Details of stamping on each item with low stress stamps: Heat number, Specification & grade, Code case number (for Gr 92 & 23), Maker's emblem/code & Inspection Authority's seal. Forgings to be properly packed and despatched to avoid damage during transit.

**10. INSPECTION AND CERTIFICATION**

**10.1 For IBR Items:**

a) Products shall be inspected at works and the applicable IBR Form must be countersigned by the Inspecting Authority as indicated below in case the shop is not recognised as a "Well known Forger/Steel maker" under IBR:

**Imported Items:** Inspecting Authority approved by IBR for the Country of origin.

**Indigenously Supplied items:** Director of Boilers/Chief Inspector of Boilers/*Inspecting Authority approved by IBR*, for the respective state.

b) Certification in IBR Form III-G for IBR items from "IBR-Well Known Forger" or "Inspecting Authority", as applicable, to be submitted. IBR Form III-G and Test certificate in English language with following details, shall accompany the product (including proof machined):

1. Purchase Order No.(BHEL), TDC No & its revision no, Test certificate no & date.
2. Specification, Grade with applicable year of code, Code case number (for Gr 92 & 23), Heat Number, Drawing No.,Quantity & Size
3. Supplier of the steel used in making the finished product (well known and others in IBR Form IV).
4. Melting & forging process, Chemistry with incidental elements-Heat wise, Product analysis, Carbon Equivalent (CE).
5. Heat treatment details of the material and test bars. For F91, F92 supplies – Photomicrograph at 400x resolution.
6. Mechanical test results- Tensile (UTS, YTS, % elongation, % reduction in area), Impact & Hardness and NDE test results with reference & acceptance standard.
7. Repair details if any, Certified copy of TC for starting material.
8. **For SS:** Measured Radioactivity levels shall be reported in the Mill Test Certificate. (Not to be recorded in IBR Form).
9. For API items, works certificate with details like QSL, Pressure-Temperature rating, size shall be issued.Records of furnace calibration and surveys shall be maintained for a period not less than five years.

**10.2 For CE-marking items** the TCs with details specified above shall be submitted as per BS EN 10204-2004.

1. For pressure parts test certificates of type 3.1 or 3.2 is acceptable.  
 Type 3.1 – Suppliers shall have ISO 9001-2008 certification certified by Notified Body recognized by European community and test certificate certified by suppliers authorized inspection representative.  
 Type 3.2 – Components inspected and test certificates certified by Notified Body recognized by European community.
2. For non-pressure parts test certificates of type 2.2 is acceptable.  
 Type 2.2 – suppliers test certificates signed by suppliers authorized inspection representative with test results as required by TDC.

**11. AUDIT CHECKS AT BHEL**

BHEL reserves the right to carry out audit checks for chemistry, HT condition, mechanical test and NDT on representative test bars or job. Supplies found defective during check or subsequent processing at BHEL, *will be rejected.*

**12. END USE**

Valve bodies, bonnets, discs, socket ends, body guides etc., Pressure part fittings in boilers & low, high temperature service like discs, socket weld tees, ells, weld neck flanges & stubs (except drum nozzles) meeting IBR, ASME Section I-2015, ASME B 16.34-2013 and API-6D 24<sup>th</sup> Edition. **Non pressure part items in boilers and valves:** For these, requirements on starting material,bend test and inspection by IBR are not required.

Venkanna Rupani	G. Panneer Selvam	S. Selvarajan	K. Rajasekaran	A. Ayyachamy	U. Revisankaran
Sr.Engineer/QA	DGM/QA	SDGM/QA	SM/Valves/Engg	SDGM/Valves/ Purchase	AGM/QA&BE
<b>Prepared By</b>	<b>Reviewed By</b>			<b>Approved By</b>	