



BHEL GOINDWAL

**TERMS AND CONDITIONS FOR**  
**(Tender Enquiry No. 1516-003 Dated 16.04.2015 Due date 08.05.2015)**  
**ITEM: Name Plates**

**DUE DATE OF OPENING: 08.05.2015**

**1. INVITING TENDERS**

Tenders in two part bids are invited from manufacturers for supply of Name Plates.

Sealed tenders in two parts; Part-I: Techno-commercial bid and Part-II: Price bid are hereby invited for supply of '**Name Plates**' as per tender enquiry. The relevant documents are attached with the Enquiry.

The two bids should be submitted in **separate sealed inner envelopes** duly mentioning the detail as follows:

Bid	Bid description	Superscribing on envelope	*** Should contain ***
Part I in First sealed envelope	Techno-Commercial Offer	Part-I (Techno-Commercial) bid against tender enquiry no:1516-003 dated 16.04.2015 due for opening on 08.05.2015	1. Acceptance of all terms and conditions of tender enquiry. (Preferred is submitting signed copy of terms and conditions; if nothing is mentioned for any term, it shall be summarily concluded that the same is acceptable and no representation whatsoever shall be entertained later on). 2. <b>Un-priced bid as per format attached. All details, i.e. whether quoted for item, duties and taxes etc. should be filled.</b>
Part II in Second sealed envelope	Price Bid	Part-II (Price) bid against tender enquiry No: 1516-003 dated 16.04.2015	<b>Price bid in the format attached. Anything other than prices mentioned in the price bid shall be considered invalid</b>

Both the sealed envelopes should be put in outer sealed envelope superscribing all details i.e. Enquiry Number, Date, Supplier's Name and Address and Item.

**Time of submission by 1500 Hrs on Due Date. Time of Techno-Commercial bid (Part I) opening is 1530 Hrs on due date. Based on evaluation of techno-commercial offers, Price bids of bidders who qualify from techno-commercial evaluation shall be opened. BHEL may decide to open the Price bid same day at 1630 hrs. If not opened on the same day, all qualifying bidders shall be notified for date of opening of Price bids.**

Sealed Tenders can be dropped in the tender box labeled as 'Tender box for MM contracts'. This tender box is located at the entrance of Admin block BHEL Goindwal.

CST, VAT & Excise duty + any cess on ED at the rates applicable shall be payable extra against ED Gate Pass valid for CENVAT benefit. Rates should clearly mention basic price of the item. Unloading of material at Main Stores of BHEL shall be arranged by BHEL. Tender may be handed over to Sh Harpreet Rai/ Head MM or Sh Pranshu in case of bulky tenders.

**Fax (01859-222061) / E-Mail (tendermm@bhelivp.in) offers received in time shall be considered only when such offers are complete in all respects.**

Order of enquiry item sl. No. shall be maintained in the quotation. The rates quoted shall be firm and fixed. No price variation is proposed and allowed.

**2. VALIDITY OF OFFERS:**

The offers shall be kept open for acceptance for **60 days** from the date of opening of the tender. In case of extension of tender opening date, the validity shall be suitably revised.

**3. SCOPE OF SUPPLY**

Material shall be supplied as per the applicable latest Technical Delivery Conditions (TDC)/ Material Standard requirements/BPS/Drawing and other requirement as given in the Purchase Order. **Wherever**



BHEL GOINDWAL

TERMS AND CONDITIONS FOR  
(Tender Enquiry No. 1516-003 Dated 16.04.2015 Due date 08.05.2015)  
ITEM: Name Plates

Trichy/Tiruchy/Tiruchirappali is written in BPS/Drawing, it may change as Goindwal and this will be informed at the time of PO Placement. National & International material Standards shall have to be arranged by vendors themselves. Comparison and procurement shall be done for Individual item, i.e. Name Plate where one bidder is found to L1 then for individual quantity PO will be released and bidder have to execute the order whatsoever be the quantity and PO value. For Supply of Name Plates +/-10% quantity may vary.

4. REPLACEMENT OF REJECTION:

If the material is rejected due to defective workmanship during inspection or at the time of actual use, the rejected material shall be replaced by the supplier. Corresponding quantity shall be treated as unsupplied against respective purchase order till replacement is received at BHEL. If the material is found defective and rejected during use for which payment has already been released the rejected quantity shall be supplied free of cost by the vendor within a month of intimation of the rejection by BHEL.

5. DELIVERY SCHEDULE:

Supplies shall be affected and completed as per schedule mentioned in the POs. We require delivery to be completed within 3 months. Further, BHEL may release delivery schedule from time to time based upon our requirement. Vendor shall be required to complete the order as per the BHEL schedule requested. All test certificates are required before /with the material at BHEL Goindwal; Otherwise BHEL may or may not receive the material. Test certificates may be send on email as mentioned on Purchase orders in scanned form. In no case material will be accepted at BHEL without test certificates.

6. ACCESS TO MANUFACTURING PREMISES:

While Purchase Orders placed on the vendor are under execution, authorized representatives of BHEL shall be allowed free access to the manufacturing facilities for the purpose of inspection or monitoring the progress of purchase orders. This access will also be extended to representatives of BHEL's customers accompanying the authorized representative/s of BHEL (which shall be intimated in advance), if our contractual requirements with our customers call for the same.

7. TERMS OF PAYMENT:

- a. Due payment against supplies received shall be due after 30 days of receipt and acceptance of material and shall be paid within next 15 days period. In case of deviation, loading shall be done at SBI baserate + 6% at time of opening of Part I.
- b. Documents to be submitted
  - i. Commercial invoice (in duplicate)
  - ii. Excise invoice (in duplicate) valid for claiming CENVAT credit
  - iii. Original VAT invoice valid for claiming input tax credit, if applicable
  - iv. Material Test Certificates (MTC) and
  - v. Compliance Certificate.
- c. Above documents should include your Registration numbers such as ECC no, PAN no, CST no, TIN/VAT nos. etc.
- d. It is mandatory to mention proper material codes in the invoices and separate invoices to be raised for different POs.
- e. BHEL releases payment through EFT mode ONLY. Necessary details may please be submitted by filling required format before release of payment.

8. INSPECTION:

- I. All required tests shall be carried out by vendor at no extra cost. Relevant TCs shall accompany the consignment. BHEL may decide to inspect itself/arrange third party at vendors' works itself as



BHEL GOINDWAL

TERMS AND CONDITIONS FOR  
(Tender Enquiry No. 1516-003 Dated 16.04.2015 Due date 01.05.2015)  
ITEM: Name Plates

and when necessary with prior intimation to the vendor. No additional charges shall be claimed for such inspections.

2. Latest applicable revisions of standards/procedures to be referred.
3. **Load test certificates required along with supplies.**
4. Any inspection carried out before supply by vendor/incoming stage at BHEL not withstanding, if any defect/non-conformity is noted during processing, the same shall be attended/replaced by vendor at no extra cost.

9. **COUNTER OFFERS**

BHEL reserves the right to negotiate with L1 or re-float the tender in case the quoted prices are not acceptable. BHEL will not give counter-offer except MSE clause.

10. **PENALTY FOR LATE DELIVERY:**

'Time is the essence of the contract'. As such, delivery of goods specified in the Purchase Orders released under the scope of this contract shall be made within the time limit prescribed therein. Penalty for late delivery will be applicable @ 0.5% per week or part thereof subject to a maximum of 10.0 %.

If any vendor does not accept LD ½% of the supply for each week of delay subject to a maximum of 5%, their offer is likely to be rejected by BHEL and the price bid shall not be opened. Bidders accepting for 10% LD shall not be loaded on account of LD. However bidders who offer any other % LD [between 5% to 10%] shall be loaded @ % deviation from 10% and their accepted %e.g. If a bidder accepts for a max of 7% LD only, their offer would be loaded @ 3% (10 - 7 = 3).

BHEL reserves the right to receive or not receive the material after the due date of PO

11. **RISK PURCHASE:**

BHEL shall be entitled to terminate the contract/pending POs at any stage and to purchase elsewhere at the risk and cost of the vendor, either the whole of the goods or any part thereof which the supplier has failed to deliver or dispatch within the time stipulated as aforesaid. Vendor shall be liable for the losses, which BHEL may sustain by way of such risk purchase in addition to aforesaid penalty for delayed delivery.

12. **SUB-CONTRACT:**

The purchase order or any part thereof shall not be sub-contracted, assigned or otherwise transferred without previously obtaining the BHEL's consent in writing.

13. **FORCE MAJEURE:**

If at any time during the continuance of the contract, the performance in which or in any part by either party of any obligations under the contract are prevented or delayed by reason of any war, hostilities, acts of public enemy, civil commotion, sabotage, fires, explosions, epidemics, quarantine restrictions, or acts of God (hereinafter referred to "an events" then provided the notice of happening of any such event is given by either party to the other within 21 days of the occurrence thereof, neither party shall by reason of such event be entitled to terminate the contract nor shall either party have any claim for damages against the other in respect of such non-performance and delay in performance and delivery under the contract shall be resumed as soon as practicable after such event has come to an end or ceased to exist. If the performance in whole or part of any obligation under the contract is prevented or delayed by reason of any such event, claims of extension of time shall be granted for periods considered reasonable by BHEL subject to prior notification by the vendor to BHEL of the particulars of the event and supply to BHEL, if required, of any supporting evidence. Any waiver of time in respect of partial installment shall not be deemed a waiver of time in respect of remaining deliveries.

**14. DISPUTES:**

In the event of any dispute and/or difference arising between the Vendor and BHEL as to interpretation and/or execution of the contract and/or the respective rights and liabilities of the parties, such disputes and/or differences shall be referred to the sole arbitrator nominated by BHEL. The provisions of the Indian Arbitration Act and the rules there under shall apply to such arbitration. The award passed by the arbitrator shall be final and conclusively binding on all the parties.

**15. JURISDICTION:**

The court of the place from where the purchase order is issued during the contractual period shall alone have jurisdiction to decide any dispute arising out of or in connection with the purchase order.

**16. MSME & MSE Certification:**

If the bidder is registered as any of Micro/Small/Medium enterprise as defined in Micro Small and Medium Enterprises Development Act, 2006; a copy of registration certificate to be attached. MSE's shall be given preferences as described in "Public Procurement Policy for Micro and Small Enterprises (MSEs) Order, 2012" subject to the submission of proper documentary evidence (i.e. District Industries Centers or Khadi and Village Industries Commission or Khadi and Village Industries Board or Coir Board or National Small Industries Corporation or Directorate of Handicrafts and Handloom or any other body specified by Ministry of Micro, Small and Medium Enterprises) with quotation. "Public Procurement Policy for Micro and Small Enterprises (MSEs) Order, 2012" document can be downloaded from link <http://dcmsme.gov.in/FinalPressorder.pdf> and can also be collected from the office of Manager/MM IVP Goindwal. Below Clause 22 need to be followed for this required documents for MSE benefits.

**17. CLARIFICATIONS**

The correspondence exchanged against the tender from both tenderer and BHEL through email are considered as valid document legally though it is not signed. It is treated as valid confirmations made on behalf of the respective company and very much comes under the legal ambit of the business transaction and hence it is binding on both the parties to the business. Any transaction pertaining to the tender from both the parties of business done round the clock irrespective of the office or business hours of the companies, are valid legally and binding on both the parties. This applies to the extent only in such cases where deadline time for transaction is not specifically declared by either or both the parties to the business.

**18. LOI (Letter of Intent)**

BHEL may issue LOI prior to the PO for any reason whatsoever. The LOI in such cases is to be treated as PO for all practical purposes and all the Terms & Conditions of the tender shall be applicable from the date of issue of LOI.

**19. GENERAL:**

- a) BHEL will not be bound by any power of attorney granted by the vendors or by changes in the composition of the firm made subsequent to the execution of the contract. They may, however, recognize such power of attorney and changes after obtaining proper legal advice, the cost of which will be chargeable to the vendor concerned.
- b) BHEL reserves the right to extend the due date of opening, which shall be informed. Validity of offer shall be deemed to be revised accordingly.





BHEL GOINDWAL

TERMS AND CONDITIONS FOR  
(Tender Enquiry No. 1516-003 Dated 16.04.2015 Due date 08.05.2015)  
ITEM: Name Plates

- c) BHEL reserves the right to accept or reject any part or whole of the tender of a bidder by assigning a valid reason thereof. BHEL reserves the right to cancel the tender without assigning any reason thereof and without any obligation before any commitment.
- d) If possible, please submit soft copy of price quotation [copied on a blank CD of standard make] put in the sealed offer.
- e) Acceptance of all terms and conditions, in the form of signed copy of T&C or confirmation separately written, shall be submitted along with quotation. If nothing is mentioned, it shall be concluded that terms and conditions are acceptable.

**20. BANNED FIRMS:**

The offers of the bidders who are on the banned list as also the offer of the bidders, who engage the services of the banned firms, shall be rejected. The list of banned firms is available on BHEL website [www.bhel.com](http://www.bhel.com).

**21. SUPPLIER REGISTRATION:**

**Bidders, who are not currently on registered list of BHEL IVP Goindwal Sahib, may submit duly filled format for "Vendor Registration form".** The form can be downloaded from our website [www.bhel.com](http://www.bhel.com) or can be requested at [hrai@bhelivp.in](mailto:hrai@bhelivp.in) or [amit@bhelivp.in](mailto:amit@bhelivp.in). Registered vendors with BHEL IVP GWL have to mention their vendor code. Registered vendors with any other unit of BHEL are also required to mention the vendor code given by respective BHEL unit along with photocopy of latest POs from BHEL unit. Techno-commercially qualified bidders may be asked for submission of supplier registration form for getting registered with BHEL, IVP, Goindwal.

**22. PREFERENCES FOR MSE'S:**

Preferences as mentioned in "Public Procurement Policy for Micro and Small Enterprises (MSEs) Order, 2012" shall be given to Micro and Small enterprises.

Main points which are mentioned in the above order are as follows:

- 20% Procurement of the tender value shall be made from MSE (Micro, Small Enterprises) firms.
- 4% from the above mentioned 20% procurement quantity shall be procured from MSE's owned by SC /ST's. Failure to participate by any MSE owned by SC/ST's this 4% quantity shall be procured from other MSEs.
- EMD shall be exempted for MSE's. All these benefits are subject to production of all statutory documents
- In tender, participating Micro and Small Enterprises quoting price within price band of L1+15 per cent shall also be allowed to supply a portion of requirement by bringing down their price to L1 price in a situation where L1 price is from someone other than a Micro and Small Enterprise and such Micro and Small Enterprise shall be allowed to supply up to 20 per cent of total tendered value. In case of more than one such Micro and Small Enterprise, the supply shall be shared proportionately (to tendered quantity).
- **Below are the documents which need to be submitted for proving the MSE nature:**

**"MSE suppliers can avail the intended benefits only if they submit along with the offer, attested copies of either EM II certificate having deemed validity (five years from the date of issue of acknowledgement in EM II) or valid NSIC certificate or EM II certificate along with attested copy of a CA certificate (Format enclosed at Annexure -1 where deemed validity of EM II certificate of five years has expired) applicable for the relevant financial year (latest audited). Date to be reckoned for determining the deemed validity will be the date of bid opening (Part 1 in case of two part bid). Non submission of such documents will lead to consideration of their bid at par with other bidders. No benefit shall be applicable for this enquiry if any deficiencies in the above**



**TERMS AND CONDITIONS FOR**  
**(Tender Enquiry No. 1516-003 Dated 16.04.2015 Due date 08.05.2015)**  
**ITEM: Name Plates**

required documents are not submitted before price bid opening. If the tender is to be submitted through a procurement portal, then the above required documents are to be uploaded on the portal. Documents should be notarized or attested by a Gazetted officer.”

**23. WORDS AND FIGURES**

- a. If, in the price structure quoted for the required goods/ services/ works, there is discrepancy between the unit price and the total price (which is obtained by multiplying the unit price by the quantity), the unit price shall prevail and the total price corrected accordingly, unless in the opinion of the purchaser there is an obvious misplacement of the decimal point in the unit price, in which case the total price as quoted shall govern and the unit price corrected accordingly.
- b. If there is an error in a total corresponding to the addition or subtraction of subtotals, the subtotals shall prevail and the total shall be corrected; and
- c. If there is a discrepancy between words and figures, the amount in words shall prevail, unless the amount expressed in words is related to an arithmetic error, in which case the amount in figures shall prevail subject of (a) and (b) above.
- d. If there is such discrepancy in an offer, the same shall be conveyed to the bidder with target date upto which the bidder has to send his acceptance on the above lines and if the bidder does not agree to the decision of the purchaser, the bid is liable to be ignored.

**24. GUARANTEE**

Vendor shall give a guarantee against manufacturing defects of 18 months from the date of dispatch or 12 months from use, whichever is earlier. In case of non-acceptance of this term bid will be rejected.

**CHECKLIST AND SEQUENCE OF DOCUMENTS TO BE SUBMITTED IN TWO PARTS BIDS**

S. No.	Document	Status
1	Envelope should contain (1) Techno-Commercial bid preferably with signed copy of terms & conditions (2) Unpriced bid format (Annexure-II) with applicable taxes (item prices not to be mentioned) (3) Authorized dealer certificate if any (4) Compliance to specified makes	Sealed envelope marked as Part-I “Techno-Commercial Bids” Yes, Sealed
2.	Price Bid (Preferably in Annexure-III) sealed in separate envelope superscribing tender enquiry detail, due date of opening, sender address	Sealed envelope marked as Part-II “Price Bid” Yes, sealed
3.	All two sealed envelopes put in an outer envelope mentioning all details like Enquiry no., description, due date	Yes



BHEL GOINDWAL

## TERMS AND CONDITIONS FOR

(Tender Enquiry No. 1516-003 Dated 16.04.2015 Due date 08.05.2015)

ITEM: Name Plates

### Annexure - I

#### **Certificate by Chartered Accountant on letter head**

This is to Certify that M/S .....  
(hereinafter referred to as 'company') having its registered office at .....  
is registered under MSMED Act 2006, (Entrepreneur  
Memorandum No (Part-11) ..... dtd:.....  
Category:..... (Micro/Small)). (Copy enclosed).

Further verified from the Books of Accounts that the investment of the company as per the latest audited financial year ..... as per MSMED Act 2006 is as follows:

1. **For Manufacturing Enterprises:** Investment in plant and machinery (i.e. original cost excluding land and building and the items specified by the Ministry of Small Scale Industries vide its notification No.S.O.1722(E) dated October 5, 2006 :

Rs.....Lacs

2. **For Service Enterprises:** Investment in equipment (original cost excluding land and building and furniture, fittings and other items not directly related to the service rendered or as may be notified under the MSMED Act, 2006:

Rs.....Lacs

(Strike off whichever is not applicable)

The above investment of Rs.....Lacs is within permissible limit of Rs.....Lacs for .....Micro / Small (Strike off which is not applicable) Category under MSMED Act 2006.

Or

The company has been graduated from its original category {Micro/ Small} (Strike off which is not applicable) and the date of graduation of such enterprise from its original category is ..... (dd/mm/yyyy) which is within the period of 3 years from the date of graduation of such enterprise from its original category as notified vide S.O.No. 3322(E) dated 01.11.2013 published in the gazette notification dated 04.11.2013 by Ministry of MSME.

Date:

(Signature)

Name-

Membership number-

Seal of Chartered Accountant

**BHARAT HEAVY ELECTRICALS LTD**  
**IVP, GOINDWAL SAHIB**  
**UNPRICE BID ANNEXURE**

**Annexure-II to Enquiry No. 1516-003 dated 16.04.2015 Due Date of submitting quotations 08.05.2015**

**Item Name Plates**

S.No	Material Code	Description of material	Technical document no.	tender qty	Unit	Quoted Yes/No
1	964532980000	CIR NAME PL.(ST.STEEL)-W345	3VW34520825/02 (Drg No.)	10	NO	
2	220745530000	CIR NAME PL16-BPS 017538	BPS 17538	100	NO	
3	220745620000	CIR NAME PL52-BPS 017538	BPS 17538	350	NO	
4	220745640000	CIR NAME PL60-BPS 017538	BPS 17538	450	NO	
5	220746490000	NAME PL-1373	4V137304047/01 (Drg No.)	1500	NO	
6	964660630000	NAME PLATE	4VG00419240/00 (Drg No.)	700	NO	
7	220741660000	NAME PLATE 20X80-BPS:017522	BPS 17522	100	NO	
8	964562250000	NAME PLATE-5329	4V532906703/02 (Drg No.)	10	NO	
9	964529860000	NAME PLATE-5730	4V573006501/03 (Drg No.)	10	NO	
10	220741280000	NM DIRECTION PLATE 20X75	BPS 17510	1500	NO	
11	220736490000	RATG.PL.WB180X108 BPS 017204	BPS 17204	1500	NO	

Excise Duty rate (mention in % if applicable, mention as **NIL** if not applicable) *Pl. clearly mention*

Cess on ED rate (mention in % if applicable) Extra@ *Pl. clearly mention*

CST (%) [Extra@](#) *Pl. clearly mention*

VAT (%) Extra@ *Pl. clearly mention*

Validity of offers (**As per BHEL terms 60 days validity is required**) *Pl. clearly mention*

Delivery terms (FOR Goindwal Sahib) *Pl. clearly mention*

MSE Firm (YES/NO) *Pl. clearly mention*

Please note that nothing will be considered other than prices in the price bid.

*Authorised signatory with seal*

**BHARAT HEAVY ELECTRICALS LTD****IVP, GOINDWAL SAHIB****PRICE BID ANNEXURE****Annexure-III to Enquiry No. 1516-003 dated 16.04.2015 Due Date of submitting quotations 08.05.2015****Item Name Plates**

S.No	Material Code	Description of material	Technical document no.	tender qty	Unit	Unit price, Rs	
						In Figures	In Numbers
1	964532980000	CIR NAME PL.(ST.STEEL)-W345	3VW34520825/02 (Drg No.)	10	NO		
2	220745530000	CIR NAME PL16-BPS 017538	BPS 17538	100	NO		
3	220745620000	CIR NAME PL52-BPS 017538	BPS 17538	350	NO		
4	220745640000	CIR NAME PL60-BPS 017538	BPS 17538	450	NO		
5	220746490000	NAME PL-1373	4V137304047/01 (Drg No.)	1500	NO		
6	964660630000	NAME PLATE	4VG00419240/00 (Drg No.)	700	NO		
7	220741660000	NAME PLATE 20X80-BPS:017522	BPS 17522	100	NO		
8	964562250000	NAME PLATE-5329	4V532906703/02 (Drg No.)	10	NO		
9	964529860000	NAME PLATE-5730	4V573006501/03 (Drg No.)	10	NO		
10	220741280000	NM DIRECTION PLATE 20X75	BPS 17510	1500	NO		
11	220736490000	RATG.PL.WB180X108 BPS 017204	BPS 17204	1500	NO		

Taxes and other conditions will be as mentioned in Unprice Bids.

*Authorised signatory with seal*

ALL DIMENSIONS ARE IN MILLIMETRES. FOR TOLERANCES OF UNTOLERANCED DIMENSIONS DURING MANUFACTURE REFER RELEVANT QCP / QP.

3-V-000-20825/2  
DRAWING NO.

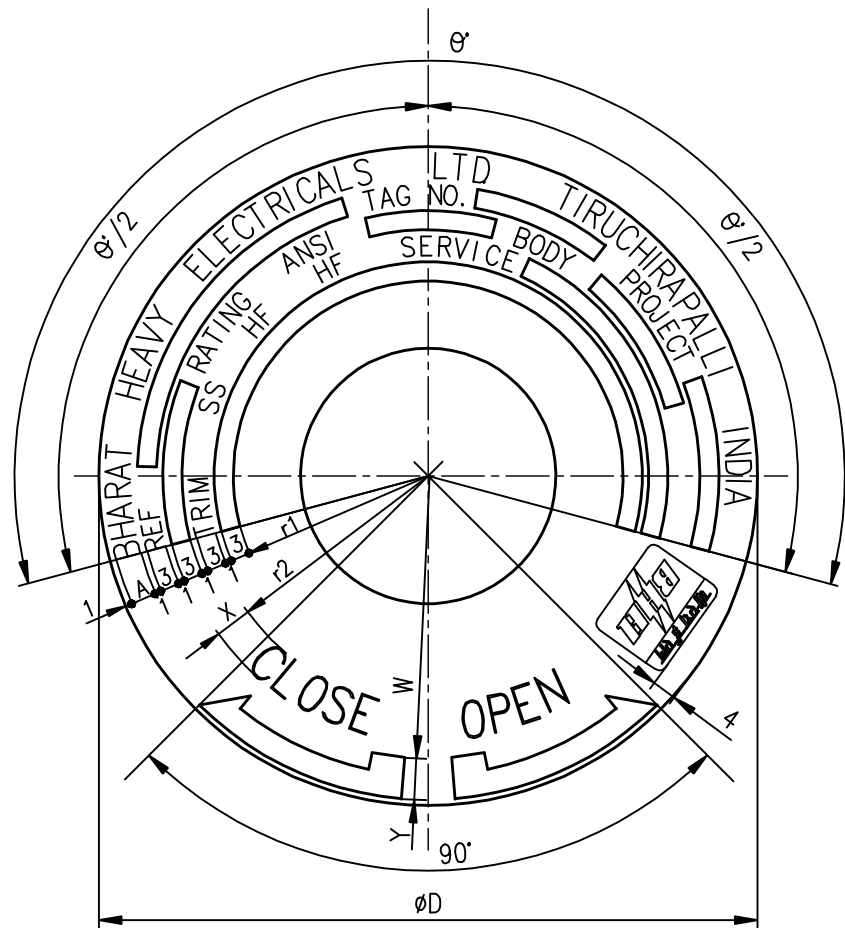

SL. NO.	DRAWING NO.	COMP. CODE	DIMENSIONS								MONOGRAM STD.	
			$\phi D$	$\phi d$	r1	r2	$\theta^\circ$	A	W	X		Y
01	3-V-G004-20825/1	964532990000	80	23	20	27	200	3	34	6	5	15-AA 040 11 20
02	3-V-G001-20825/1	964533000000	80	27	20	27	200	3	34	6	5	15-AA 040 11 20
03	3-V-W005-20825/1	964533010000	125	52	41.5	42.5	165	4	53.5	10	7	15-AA 040 11 20
04	3-V-W002-20825/1	964532970000	160	62.5	59	60	128	4	71	10	7	25-AA 040 11 20
05	3-V-W006-20825/1	964533020000	160	72.5	59	60	128	4	71	10	7	25-AA 040 11 20
06	3-V-W113-20825/1	964533030000	160	82.5	59	60	128	4	71	10	7	25-AA 040 11 20
07	3-V-W003-20825/1	964533040000	200	86	79	80	102	4	91	10	7	40-AA 040 11 20
08	3-V-W117-20825/1	964533050000	200	96	79	80	102	4	91	10	7	40-AA 040 11 20
09	3-V-W004-20825/1	964533060000	200	102.5	79	80	102	4	91	10	7	40-AA 040 11 20
10	3-V-W345-20825/2	964532980000	120	50	39	40	172	4	51	10	7	15-AA 040 11 20
11	3-V-R009-20825/2	964533070000	125	58	41.5	42.5	165	4	53.5	10	7	15-AA 040 11 20
12	3-V-W065-20825/2	964533080000	145	70	51.5	52.5	143	4	63.5	10	7	25-AA 040 11 20
13	3-V-R033-20825/2	964533090000	170	90	64	65	122	4	76	10	7	25-AA 040 11 20

**NOTES:**

- MATERIAL: 18-8 Cr. Ni STAINLESS STEEL.
- THE NAME PLATE SHALL HAVE RAISED BRIGHT POLISHED LETTERS, EMBLEM ETC., ON ETCHED BLACK ENAMELLED BACKGROUND.
- THE ENAMEL SHALL BE CRACK RESISTING SO THAT WHEN BENT THE ENAMEL DOES NOT CRACK.
- MONOGRAM SHALL BE BASED ON CORPORATE STANDARD No. AA 040 11 20 REV.1
- FINAL THICKNESS OF THE NAME PLATE AFTER ETCHING, ENAMELLING & POLISHING SHALL NOT BE LESS THAN 0.5mm. SUPPLIERS SHALL TAKE SUITABLE RAW MATERIAL THICKNESS TO MEET THE SPECIFIED FINAL THICKNESS.
- THIN LINES SHOWN ARE FOR SPACING PURPOSE ONLY AND SHOULD NOT BE PRINTED.

REDRAWN WITH REV.1 ON 12.04.08

REV	DATE	ALTERED	GANESH	REV	DATE	ALTERED	VB
2	08.08.11	CHD & APPD	GANESH&KRS	1	12.04.08	CHD & APPD	KRS&MRK
		MONOGRAM STANDARD HAS BEEN CHANGED FOR SL No.-10,11,12 & 13 DCP: 801209				DRAWING CONVERTED INTO SOFT COPY DCP No.800813	

CAUTION: The information on this document is the property of BHARAT HEAVY ELECTRICALS LTD. It must not be used directly or indirectly in any way detrimental to the interest of the company.

NO OFF	DESCRIPTION	MATL CODE	MATL SPECN	HEAT TREATMENT	SCRAP SORT	NET WT (kg)	GROSS WT (kg)	DRAWING No	ITEM No
	TYPE OF PRODUCT OR NAME OF CUSTOMER/PROJECT <b>TA</b>								
	<b>BHARAT HEAVY ELECTRICALS LTD.,</b> UNIT: HIGH PRESSURE BOILER PLANT. TIRUCHIRAPALLI-620014.				DRN	V.SIVALINGAM	SIGN	DATE	NO.OF VAR.
	365-121				CHD	K.RAJASEKARAN		12.04.08	
					APPD	M.RAJAKUMAR		12.04.08	
DEPT	VL	SCALE		WEIGHT (KG).		REFERENCE INFORMATION			NO. OF ITEMS
CODE	320	N.T.S							
TITLE						CARD CODE	DRAWING NO.		REV
<b>CIRCULAR NAME PLATE</b>						U 01	<b>3-V-0000-20825</b>		<b>2</b>



# PLANT STANDARD

HPBP TIRUCHIRAPPALLI

BPS 017538

64

Rev. No. 01

PAGE 1 OF 3

## CIRCULAR NAME PLATE FOR VALVES

### 0.0 SCOPE

This standard covers the requirements of Circular name plate for valves.

### 1.0 SPECIFICATION AND REFERENCE STANDARDS

Dimensions and preferred sizes	Fig.1 and table 1 of this standard
Tolerance	Medium to IS: 2102
Material	Aluminium sheet of thickness 1 mm
Lettering style	According to corporate standard AA 042 1403
Finish	See clause 2.1 of this standard
Technical delivery conditions	Acc. to clause 3.0 to 3.3.2 of this standard

### 2.0 FINISH

2.1 Name plates shall be hard anodized according to IS:6057 incorporating matter, letters and border in blue colour with white background.

### 3.0 TECHNICAL REQUIREMENTS

#### 3.1 GENERAL

3.1.1 The surface shall be free of cracks, blisters and damages. Sharp edges shall be rounded off.

3.1.2 Samples of the name plates shall be obtained and tested in the laboratory for durability of the material, anodizing and weather proofness before bulk supply is effected.

3.2 MARKING. Back side of each name plate shall be marked with material code given by BHEL and with manufacturer's identification.

Revisions

Brought upto date

Approved

STANDARDS SECTION  
CONTRACT ENGINEERING AND CO-ORDINATION  
HPBP, TIRUCHIRAPPALLI

Rev. No. 01

Amd. No.

Reaffirmed

Prepared

Issued

Dt of 1st Issue

Dt. 18.01.97

Dt.

Year

STANDARDS

STANDARDS

MAR 1986



# PLANT STANDARD

HPBP TIRUCHIRAPPALLI

BPS 017538

65

Rev. No. 01

PAGE 2 OF 3

## 3.3 PACKING.

3.3.1 Before packing, each name plate shall be applied with transparent synthetic adhesive film.

3.3.2 Each name plate shall be suitably packed in polythene cover (500 microns thickness minimum) in order to avoid any damage to the surface during transit/storage etc.

## 4.0 DESIGNATION

A circular name plate for valve of size 24 to this standard shall be designated as :

### 4.1 On drawings

a) Description column : NPL CIR VALVE 24

b) Drawing number column : BPS 017538 0024

c) Material spec. column : Aluminium

d) Material code column : 22 074 555

### 4.2 Ordering description

For placing indents, issuing enquiries and on purchase orders, ordering description given below shall be followed.

Circular name plate for valves, size 24 to BPS 017538

## 5.0 ADDITIONAL INFORMATION

5.1 Copies of the following standards shall be enclosed along with purchase order.

a) BPS 017 538

b) AA 042 1403

5.2 The figure shown is for illustration only and supplier has to submit drawings to actual size for approval before effecting bulk supplies,



# PLANT STANDARD

HPBP TIRUCHIRAPPALLI

BPS 017538

66

Rev. No. 01

PAGE 3 OF 3

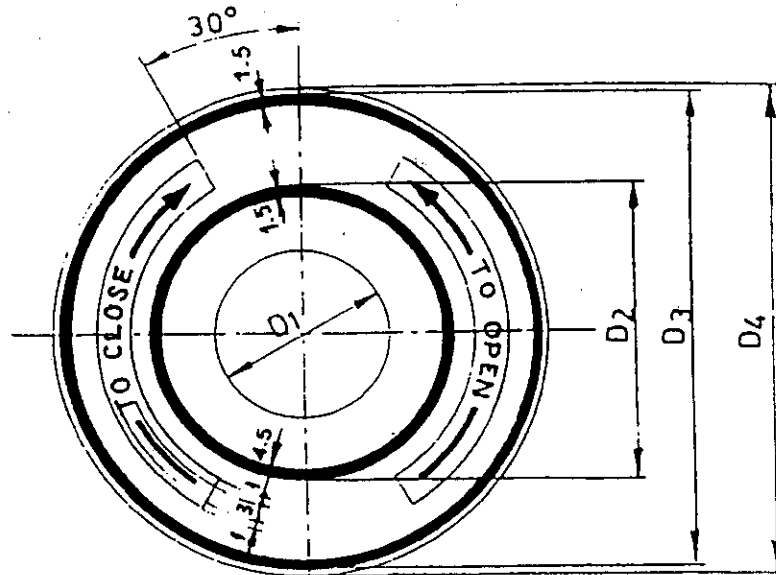

Figure 1

TABLE 1

(All dimensions in millimetres)

Nomi- nal size	D <sub>1</sub>	D <sub>2</sub>	D <sub>3</sub>	D <sub>4</sub>	Corresponding size of hand- wheel retain- ing nut	wt/1000 pieces in.kg
6	6.4	34	60	62	M6	7.47
8	8.4	34	60	62	M8	7.41
10	10.5	34	60	62	M10	7.33
12	13.0	34	60	62	M12	7.22
16	17.0	34	60	62	M16	6.98
20	21.0	39	65	67	M20	7.95
24	25.0	44	70	72	M24	3.95
27	28.0	49	75	77	M27	10.10
30	31.0	56	82	84	M30	11.97
36	37.0	61	87	89	M36	12.87
39	40.0	66	92	94	M39	14.21
42	43.0	71	97	99	M42	15.61
45	46.0	71	97	99	M45	15.09
52	54.0	81	107	109	M52	17.60
56	58.0	81	107	109	M56	16.72
60	62.0	106	132	134	M60	27.71
64	66.0	92	118	120	M64	19.72



ALL DIMENSIONS ARE IN MILLIMETRES.

FOR TOLERANCES OF UNTOLERANCED DIMENSIONS DURING MANUFACTURE REFER RELEVANT QCP/QP

REV 01	DATE 23.03.00	ALTERED K.P.LEON <i>John</i> CHD & APPD <i>Wb</i>
DIMENSION 80 WAS 75. DIMENSION 25 INTRODUCED. DIMENSION 35 WAS 30. TRIM SPACING INCREASED BY 5mm. REFER DCN:CS:1081		

SIZE OF LETTERS		~Wt./1000 in kg.
ENAMELLED	PUNCHED	
2.0	1.5	4.43

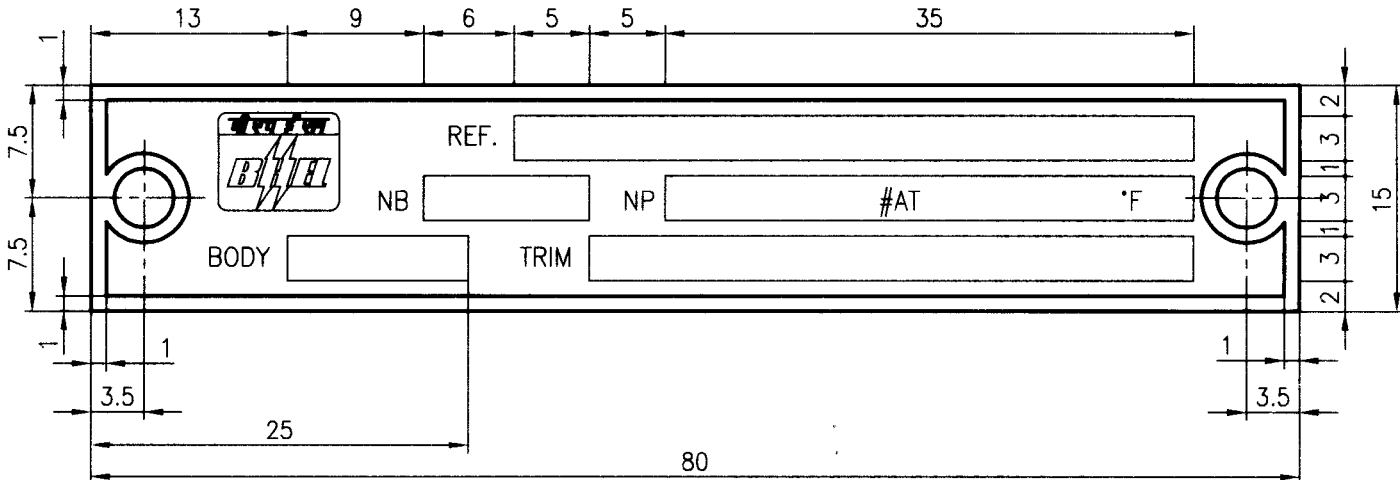

**NOTES:**

1. MATERIAL : 18/8 Cr.Ni. STEEL SHEET 0.5 mm THICK.
2. THE NAME PLATE SHALL HAVE RAISED BRIGHT POLISHED LETTERS. SPACES FOR DATA, EMBLEM AND BORDER ON ETCHED BLACK BACKGROUND.
3. THE MATERIAL OF WHICH THE BODY AND THE TRIM ARE MADE SHALL BE INDICATED BY CODES AS PER MSS-SP:25.
4. SCREW NAILS FOR FIXING NAME PLATES: SCREW NAILS SIZE 3 x 8 AS PER APPLICABLE STANDARDS.
5. THE NOMINAL BORE 'NB' WILL REPRESENT THE NOMINAL PIPE SIZE IN INCHES AND NOMINAL PRESSURE 'NP' WILL REPRESENT PRIMARY SERVICE PRESSURE IN (psig) AND CORRESPONDING SERVICE TEMPERATURE IN °F.
6. THE NAME PLATE SHALL BE CRACK-RESISTING SO THAT WHEN BENT THE ETCHING DOES NOT CRACK.
7. THE LOCATION OF THE NAME PLATE ON VALVES SHALL BE SPECIFIED BY THE DESIGNER.
8. AFTER FINALISING THE PURCHASE ORDER, SAMPLES OF THE NAME PLATE SHOULD BE TESTED IN THE LABORATORY FOR DURABILITY OF MATERIAL, ETCHING QUALITY ETC. BEFORE BULK SUPPLY IS EFFECTED.
9. THE EMBLEM SHALL BE BASED ON LATEST APPLICABLE STANDARDS.



-	-	-	-	-	-	-	-	-	-
NO OFF	DESCRIPTION	MATL CODE	MATL SPECN	HEAT TREATMENT	SCRAP SORT	NET WT (kg)	GROSS WT (kg)	DRAWING No	ITEM No



**BHARAT HEAVY ELECTRICALS LTD.**  
 UNIT: HIGH PRESSURE BOILER PLANT.  
 TIRUCHIRAPALLI 620014.

DRN	NAME K.P.LEON	SIGN <i>John</i>	DATE 23.03.2k	NO.OF VAR
CHD	T.R.R.MURTHY	<i>T.R.R.M</i>	23.03.2k	
APPD	K.S.RAMAN	<i>Wb</i>	23.03.2k	

DEPT VL	/	⊕	SCALE	WEIGHT (KG).	REFERENCE INFORMATIONS	NO. OF ITEMS
CODE 320			2:1	--	Component Code : 220746490000 CAD :C404047	

TITLE	CARD CODE	DRAWING NO.	REV
<b>NAME PLATE FOR VALVES (SS)</b>	U 01	<b>4-V-1373-04047</b>	<b>01</b>

CAUTION: The information on this document is the property of BHARAT HEAVY ELECTRICALS LTD. It must not be used directly or indirectly in any way detrimental to the interest of the company.

FOR TOLERANCES OF UNTOLERANCED DIMENSIONS

ALL DIMENSIONS ARE IN MILLIMETRES.  
DURING MANUFACTURE REFER RELEVANT QCP/QP

REV	DATE	ALTERED
		CHD & APPD

CAUTION: The information on this document is the property of BHARAT HEAVY ELECTRICALS LTD. It must not be used directly or indirectly in any way detrimental to the interest of the company.

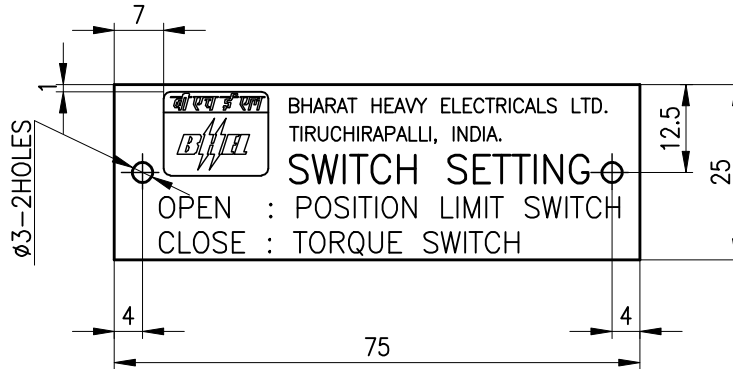

### APPLICATION:

FOR ALL MOTOR OPERATED VALVES  
EXCEPT 100mm & ABOVE 1500 CLASS AND ABOVE GATE VALVES

### NOTES:

1. MATERIAL IS STAINLESS STEEL
2. THICKNESS OF THE PLATE 1mm
3. MONOGRAM SHALL BE BASED ON CORPORATE STANDARD No. AA0401120 REV.1
4. THE NAME PLATE SHALL BE CRACK RESISTING SO THAT WHEN BENT, THE PLATING DOES NOT CRACK
5. THE NAME PLATE SHALL HAVE RAISED BRIGHT WHITE LETTERS, EMBLEM ETC ON ETCHED BLACK BACKGROUND

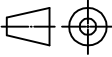
		96466063							
NO OFF	DESCRIPTION	MATL CODE	MATL SPECN	HEAT TREATMENT	SCRAP SORT	NET WT (kg)	GROSS WT (kg)	DRAWING No	ITEM No
	 <b>BHARAT HEAVY ELECTRICALS LTD.,</b> UNIT: HIGH PRESSURE BOILER PLANT. TIRUCHIRAPALLI 620014. 365-122								
		DRN	V.BAIRAVAN	SIGN	DATE	NO.OF VAR			
		CHD	S.SATHEES		08.10.10				
		APPD	K.RAJASEKARAN		08.10.10				
DEPT VL	SCALE	WEIGHT (KG).	REFERENCE INFORMATIONS	NO. OF ITEMS					
CODE 320	 N.T.S								
TITLE	CARD CODE	DRAWING NO.	REV						
NAME PLATE (FOR CONVENTIONAL VALVES)	U 01	4-V-G004-19240							



# PLANT STANDARD

HPBP TIRUCHIRAPPALLI

BPS 017522

Rev. No. 02

PAGE 1 OF 3

## NAME PLATE FOR VALVES

### 0.0 SCOPE

This standard covers the requirements of Name Plate for valves.

### 1.0 SPECIFICATION AND REFERENCE STANDARDS

Dimensions and preferred sizes	Fig.1 and table 1 of this standard
Tolerance	Medium to IS: 2102
Material	Aluminium sheet of thickness 0.5 mm
BHEL Monogram	According to corporate standard AA 040 1120
Lettering style	Acc. to corporate standard AA 042 1403
Finish	See clause 2.1 of this standard
Technical delivery conditions	Acc. to clause 3.0 to 3.3.2 of this standard

### 2.0 FINISH

2.1 The Name plate shall be hard anodized according to IS: 6057 incorporating the matter as shown in the figure 1. The letters, space for data, BHEL monogram and border shall be finished bright white with black background.

### 3.0 TECHNICAL REQUIREMENTS

#### 3.1 GENERAL

3.1.1 The surface shall be free of cracks, blisters and damages. Sharp edges shall be rounded off.

3.1.2 Samples of the name plate shall be obtained and tested in the laboratory for durability of the material, anodizing and weather proofness before bulk supply is effected.

Revisions

Brought upto date

Approved

STANDARDS SECTION -  
CONTRACT ENGINEERING AND CO-ORDINATION  
HPBP, TIRUCHIRAPPALLI

Rev. No. 02	Amd. No.	Reaffirmed	Prepared	Issued	Dt of 1st Issue
Dt. 18-1-'97	Dt. -	Year	STANDARDS	STANDARDS	AUG 1984

COPYRIGHT AND CONFIDENTIAL  
The information on this document is the property of BIHARAT HEAVY ELECTRICALS LIMITED. It must not be used directly or indirectly in any way detrimental to the interest of the company.



# PLANT STANDARD

HPSP TIRUCHIRAPPALLI

BPS 017522

Rev.No. 02

PAGE 2 OF 3

3.2 MARKING. Back side of each name plate shall be marked with material code given by BHEL and with manufacturer's identification.

3.3 PACKING.

3.3.1 Before packing, each name plate shall be applied with transparent synthetic adhesive film.

3.3.2 Each name plate shall be suitably packed in polythene cover (500 microns thickness minimum) in order to avoid any damage to the surface during transit/storage etc.

4.0 DESIGNATION

A Name plate for valve of size 15x55 to this standard shall be designated as :

4.1 On drawings

- |                          |                     |
|--------------------------|---------------------|
| a) Description column    | : NPL VALVES 15x55  |
| b) Drawing number column | : BPS 017522 1555   |
| c) Material spec. column | : Aluminium         |
| d) Material code column  | : <u>22 074 165</u> |

4.2 Ordering description

For placing indents, issuing enquiries and on purchase orders, ordering description given below shall be followed.

Name plate for valves of size 15x55 to BPS 017522

5.0 ADDITIONAL INFORMATION

5.1 Copies of the following standards shall be enclosed along with purchase order.

- a) BPS 017 522
- b) AA 040 1120
- c) AA 042 1403

5.2 The figure shown is for illustration only and supplier has to submit drawings to actual size for approval before effecting bulk supplies.

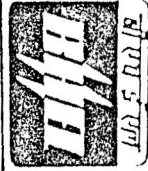

# PLANT STANDARD

HPBP TIRUCHIRAPPALLI

BPS 017522

Rev. No. 02

PAGE 3 OF 3

FIG. 1

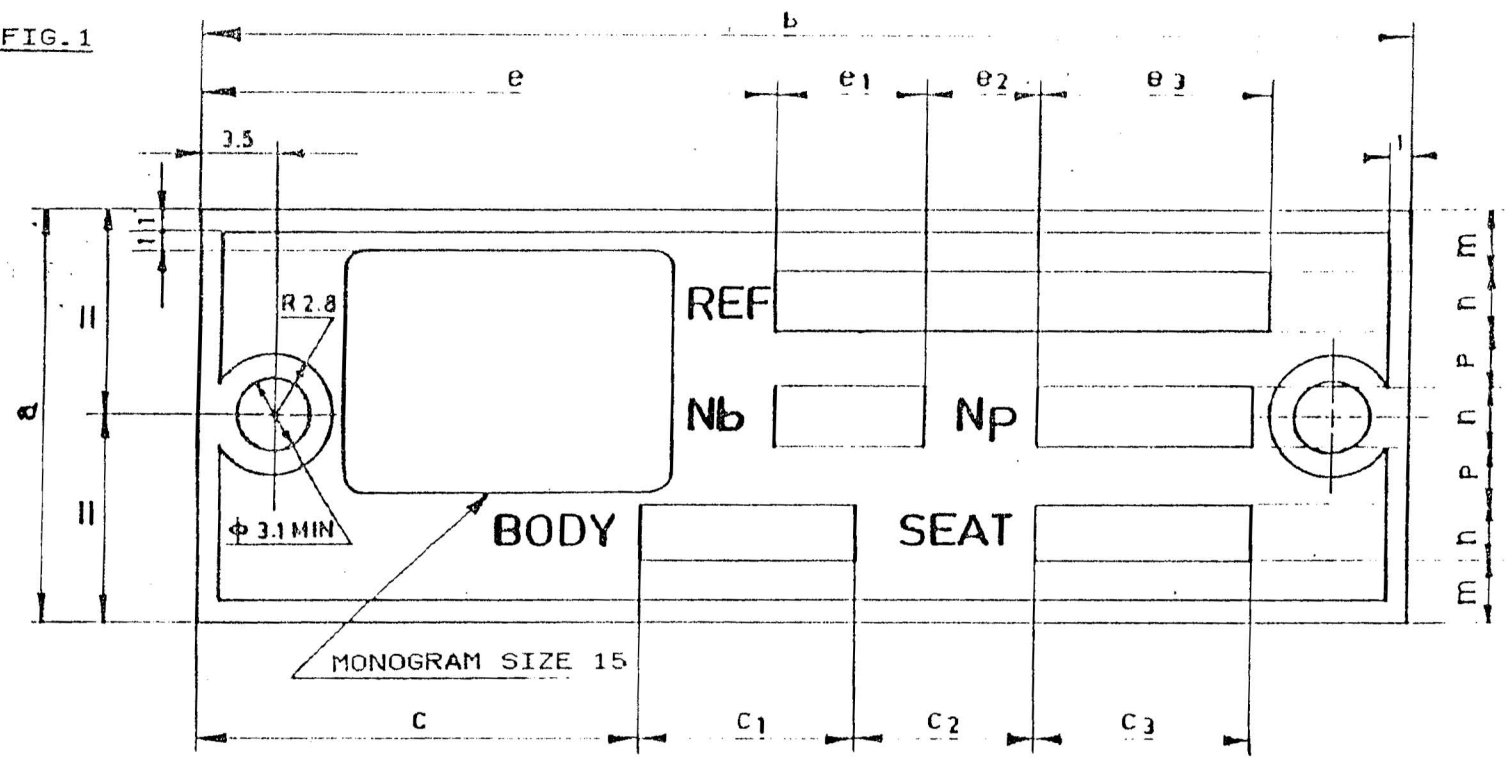

TABLE:1

(ALL DIMENSIONS IN MILLIMETRES)

SIZE a x b	c	c <sub>1</sub>	c <sub>2</sub>	c <sub>3</sub>	e	e <sub>1</sub>	e <sub>2</sub>	e <sub>3</sub>	m	n	p	ENAMELLED	PUNCHED	≈WEIGHT/ 1000 IN kg
												2	1.5	
20 X 80	23	20	10	20	33	12	8	20.7	3	4	1	2	2	2.16
15 X 55	20	10	8	10	26	7	5	10.7	2	3	1	2	1.5	1.12

CAUTION: The information on this document is the property of BHARAT HEAVY ELECTRICALS LTD. It must not be used directly or indirectly in any way detrimental to the interest of the company.

FOR TOLERANCES OF UNTOLERANCED DIMENSIONS

ALL DIMENSIONS ARE IN MILLIMETRES.  
DURING MANUFACTURE REFER RELEVANT QCP/QP

REV 02	DATE	ALTERED T.R.R.MURTHY
	31.01.06	CHD & APPD P.B.NATHAN
DCP:800557	TRIM CR13 CR13 HF WAS CR13 CR13 CR13	

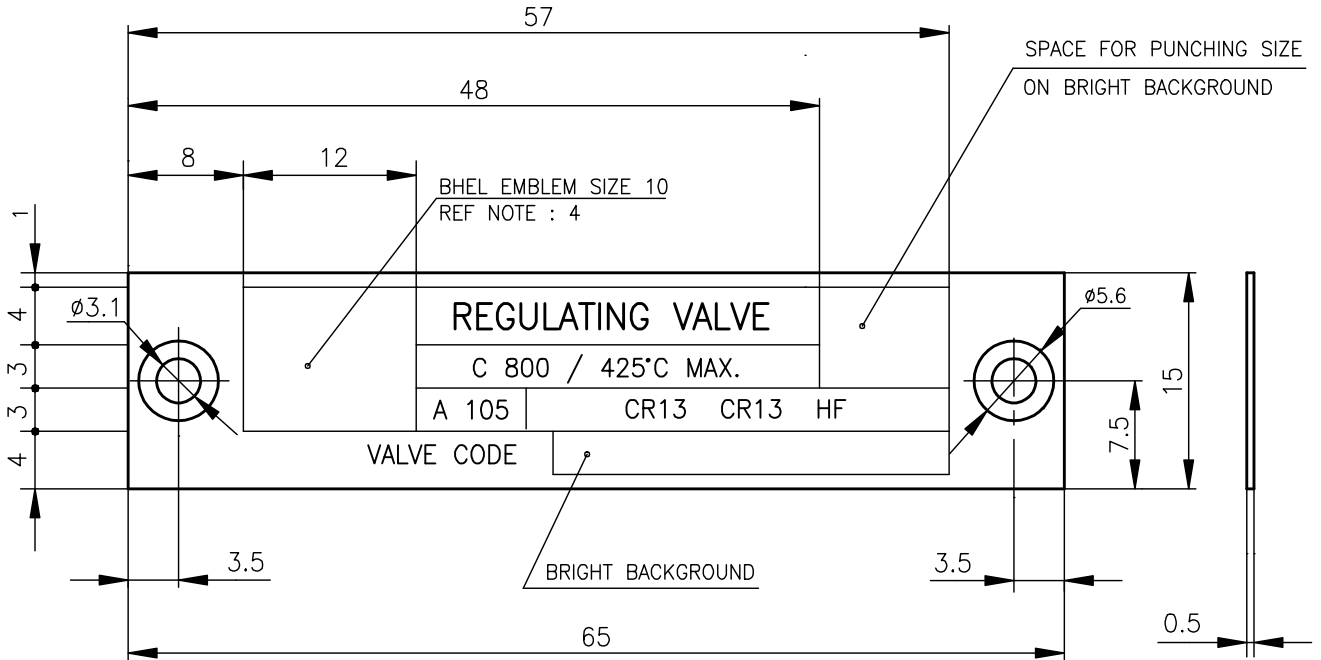

**NOTES :-**

1. MATERIAL : 18-8 Cr. Ni. STAINLESS STEEL.
2. THE NAME PLATE SHALL HAVE RAISED BRIGHT POLISHED LETTERS, MONOGRAM, ETC. ON ETCHED BLACK ENAMELLED BACKGROUND.
3. THE ENAMEL SHALL BE CRACK RESISTING SO THAT WHEN BENT THE ENAMEL DOES NOT CRACK.
4. MONOGRAM SHALL BE BASED ONCORPORATE STANDARED No. AA 040 11 20 (LATEST REV.)
5. FINAL THICKNESS OF THE NAME PLATE AFTER ETCHING, ENAMELLING & POLISHING SHALL NOT BE LESS THAN 0.5mm. SUPPLIERS SHALL TAKE SUITABLE RAW MATERIAL THICKNESS TO MEET THE SPECIFIED FINAL THICKNESS.

-	-	-	-	-	-	-	-	-	-	
NO OFF	DESCRIPTION	MATL CODE	MATL SPECN	HEAT TREATMENT	SCRAP SORT	NET WT (kg)	GROSS WT (kg)	DRAWING No	ITEM No	
	 <b>BHARAT HEAVY ELECTRICALS LTD.,</b> UNIT: HIGH PRESSURE BOILER PLANT. TIRUCHIRAPALLI 620014. 365-122									
		DRN	M.SRINIVASAN					SIGN	DATE	NO.OF VAR
		CHD	N.P.ESWAR.						21.10.92	
		APPD	N.NAGARAJAN.					21.10.92		
DEPT	VL	SCALE	WEIGHT (KG).	REFERENCE INFORMATIONS				NO. OF ITEMS		
CODE	320	NTS	0.003	COMP.CODE:96 456 225 0000 CAD:F406703						
TITLE	CARD CODE	DRAWING NO.	REV							
NAME PLATE	U 01	4-V-5329-06703	02							

FOR TOLERANCES OF UNTOLERANCED DIMENSIONS

ALL DIMENSIONS ARE IN MILLIMETRES.  
DURING MANUFACTURE REFER RELEVANT QCP/QP

REV 03	DATE 31.03.08	ALTERED M.SRINIVASAN CHD & APPD P.Boomnathan
DCP:800814 DRAWING CONVERTED INTO AUTOCAD.		

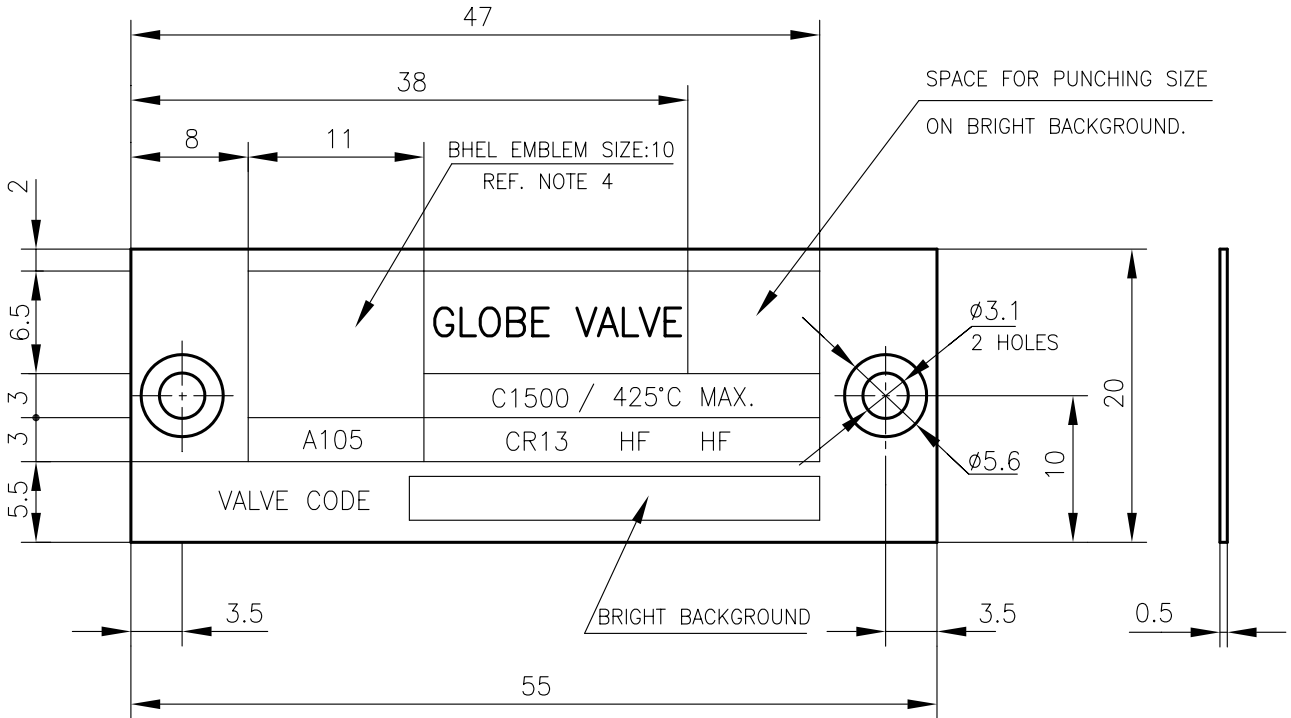

**NOTES :-**

1. MATERIAL : 18-8 Cr. Ni. STAINLESS STEEL.
2. THE NAME PLATE SHALL HAVE RAISED BRIGHT POLISHED LETTERS, MONOGRAM, ETC. ON ETCHED BLACK ENAMELLED BACKGROUND.
3. THE ENAMEL SHALL BE CRACK RESISTING SO THAT WHEN BENT THE ENAMEL DOES NOT CRACK.
4. MONOGRAM SHALL BE BASED ON CORPORATE STANDARED No. AA 040 11 20 (LATEST REV.)
5. FINAL THICKNESS OF THE NAME PLATE AFTER ETCHING, ENAMELLING & POLISHING SHALL NOT BE LESS THAN 0.5mm. SUPPLIERS SHALL TAKE SUITABLE RAW MATERIAL THICKNESS TO MEET THE SPECIFIED FINAL THICKNESS.

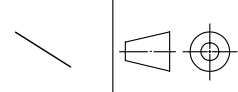
-	-	-	-	-	-	-	-	-	-
NO OFF	DESCRIPTION	MATL CODE	MATL SPECN	HEAT TREATMENT	SCRAP SORT	NET WT (kg)	GROSS WT (kg)	DRAWING No	ITEM No
 365-122	BHARAT HEAVY ELECTRICALS LTD., UNIT: HIGH PRESSURE BOILER PLANT. TIRUCHIRAPALLI 620014.	NAME		SIGN		DATE		NO.OF VAR	
		DRN	P.JAYARAMAN			12.04.89			
		CHD	M.SRINIVASAN			12.04.89			
		APPD	N.NAGARAJAN			12.04.89			
DEPT VL		SCALE	WEIGHT (KG).		REFERENCE INFORMATIONS			NO. OF ITEMS	
CODE 320		N T S	0.003		COMP. CODE: 96 452 986 0000 CAD:F406501				
TITLE					CARD CODE	DRAWING NO.		REV	
NAME PLATE					U 01	4-V-5730-06501		03	

CAUTION: The information on this document is the property of BHARAT HEAVY ELECTRICALS LTD. It must not be used directly or indirectly in any way detrimental to the interest of the company.



# PLANT STANDARD

HPBP TIRUCHIRAPALLI

BPS : 017510

PAGE 1 OF 3

## DIRECTION PLATE (STRAIGHT DIRECTION INDICATOR)

### 1 SCOPE

- 1.1 This standard stipulates the requirements of the Direction plate to be put on the equipments/products of BHEL.
- 1.2 This standard supersedes the earlier version of BPS: 017510

### 2 DESIGNATION

- 2.1 A straight direction plate B x L = 20x75 shall be designated as:

Straight direction plate 20x75 - BPS: 017510

- 2.1.1 On design documents:

- i) Description column: NPL DTN PLATE 20x75
- ii) Drawing No. column: 017510 2075
- iii) Material specn column: Brass
- iv) Material code column : 22 074 128

- 2.2 On indents: Direction plate (Straight direction indicator-BPS: 017510)

- 2.3 On purchase orders/enquiries: While issuing enquiries/purchase orders a copy of this standard shall be enclosed

### 3 COMPLIANCE WITH STANDARDS

#### 3.1 Dimensions

- 3.1.1 Direction plate and arrow sizes etc shall be as shown in the figure and Table 1.

- 3.2 Material: Cold rolled brass sheet grade CuZn37, 1/4Hard t IS: 410.

REVISIONS

DATE

APPROVED

STANDARDS SECTION  
ENGINEERING AND DEVELOPMENT CENTRE  
HPBP TIRUCHIRAPALLI

PREPARED

HPBP TIRUCHY

ISSUED

EDC/Standards

DATE

20.08.84



# PLANT STANDARD

HPBP TIRUCHIRAPALLI

BPS: 017510

PAGE 2 OF 3

3.3 Finish: Arrow and border shall be raised and bright nickel plated, followed by chromium plating according to IS: 4827. The thickness of nickel plating shall be 20 microns minimum and the chromium plating 0.3 microns minimum.

## 4 TEST REQUIREMENTS

4.1 Before finalising the purchase order the samples of the plate shall be procured and humidity test, resistant to salt spray test conducted according to corporate standard AA 040 12 02.

### 4.2 Accelerated weather proof test

4.2.1 The paint should not show any sign of deterioration when subjected to accelerated weathering test of 21 days in accordance with clause A4 of IS: 2932.

## 5 FIXING HOLES AND SCREWS

5.1 Dimensions of fixing holes, size etc shall be as shown in Figure. Screw size shall be as shown in Table 1.

## 6 MARKING AND PACKING

6.1 BPS code 017510 2075 and material code (22 074 128) shall be painted at the back of each direction plate.

6.2 Each direction plate should be suitably packed in polythene cover (500 microns thickness) so as to avoid any damage to the finish during transit/storing.

## 7 NOTE

7.1 The background of arrow shall be etched and finished black. The depth of etching shall be 100 to 500 microns.

7.2 Weight is calculated on the basis that brass weighs 8.6 kg/dm<sup>3</sup>.

7.3 Sharp edges shall be rounded off and burrs removed.



# PLANT STANDARD

HPBP TIRUCHIRAPALLI

BPS: 017510

PAGE 3 OF 3

The information on this document is the property of BHARAT HEAVY ELECTRICALS LIMITED. It must not be used directly or indirectly in any way detrimental to the interest of the company.

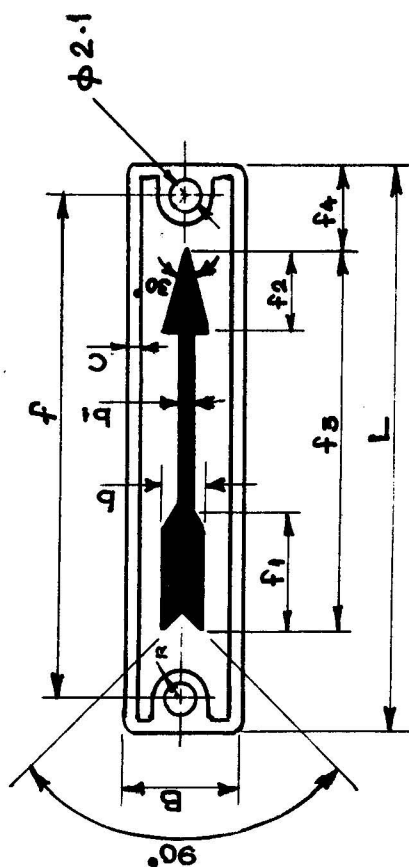

TABLE : 1. (ALL DIMENSIONS IN MILLIMETRES)

L	B	f1	f2	f3	f4	f	b	b1	R	C	THICK NESS OF PLATE	NORMAL SIZE OF SCREEN	≈ WEIGHT/1000 IN KG.
75	20	15	10	45	15	67	15	5	4	2	1	O (2x6)	12.9



# PLANT STANDARD

HPBP TIRUCHIRAPPALLI

BPS 017204

Rev. No. 03

PAGE 1 OF 4

## RATING PLATE-WALL DESLAGGER

### 0.0 SCOPE

This standard covers the requirements of Rating Plate for wall deslagger.

### 1.0 SPECIFICATION AND REFERENCE STANDARDS

Dimensions and preferred sizes	Fig.1 of this standard
Tolerance	Medium to IS: 2102
Material	CuSn37 HA, 1.6 mm thick acc. to IS 410
BHEL monogram	Acc. to corporate standard AA 040 1120
Lettering style	Acc. to corporate standard AA 042 1403
Finish	See clauses 2.0 to 2.5 of this standard
Technical delivery conditions	Acc. to corporate standard AA 085 1411

### 2.0 FINISH

2.1 All rating plates shall be manufactured by etching and shall meet the following technical and other requirements.

2.2 TOP PORTION: All letters of the name of the company and monogram with border shall be raised and bright nickel plated. The background shall be etched and finished black (stoving enamel).

2.3 MIDDLE PORTION:

2.3.1 The following details of this portion shall be raised and bright nickel plated.

Revisions

**Brought upto date**

Approved

STANDARDS SECTION  
CONTRACT ENGINEERING AND CO-ORDINATION  
HPBP, TIRUCHIRAPPALLI

Rev. No. **03**

Amd. No.

Reaffirmed

Prepared

Issued

Dt of 1st Issue

Dt. **18.01.97**

Dt.

Year

STANDARDS

STANDARDS

**JAN. 1984**



# PLANT STANDARD

HPBP TIRUCHIRAPPALLI

BPS 017204

Rev. No. 03

PAGE 2 OF 4

- All letters of the name of the equipment.
- All 'pads' on which the rating particulars shall appear.

2.3.2 The following details of this portion shall be etched and finished black (stoving enamel).

- All letters, numerals etc. of the rating details appearing on the pads.
- All the dividing lines separating the pads from each other.
- Remaining area in the background

2.4 BOTTOM PORTION: All letters shall be raised and bright nickel plated. Remaining area in the background shall be etched and finished black (stoving enamel).

2.5 Border around the rating plate and the two dividing lines shall be raised and bright nickel plated.

### 3.0 DESIGNATION

A rating plate of size 180 mm length and 108 mm width to this standard shall be designated as :

3.1 On drawings

- a) Description column : RATG PL-WB 180x108
- b) Drawing number column : BPS 017204
- c) Material spec. column : Brass
- d) Material code column : 22 073 649

3.2 Ordering description

For placing indents, issuing enquiries and on purchase orders, ordering description given below shall be followed.

Rating plate - wall deslagger to BPS 017204



# PLANT STANDARD

HPBP TIRUCHIRAPPALLI

BPS 017204

Rev. No. 03

PAGE 3 OF 4

## 4.0 ADDITIONAL INFORMATION

4.1 Copies of the following standards shall be enclosed along with purchase order.

a) BPS 017 204

b) AA 040 1120

c) AA 042 1403

d) AA 085 1411

4.2 Material code shall be painted at the back of each piece.

4.3 The figure shown is for illustration only and supplier has to submit drawings to actual size for approval before effecting bulk supplies.

