



BHEL GOINDWAL

SPECIAL TERMS AND CONDITIONS FOR
(Tender Enquiry No. 1617-015 Dated 03.05.2016 Due date 24.05.2016)
ITEM: Name Plates

Tender Enquiry No	1617-015
Enquiry date	03.05.2016
Last time and date of tender submission	15:00 Hrs 24.05.2016
Tender opening time and date	15:30 Hrs 24.05.2016
Quotation Parts	<u>Two-part</u>
Item Description	<u>Name Plates</u>
Delivery schedule (In days)	<u>90</u>
Validity of offer (In days)	<u>60</u>
Documents required along with supply of material	<u>Applicable</u>
1. Test Certificate	<u>Required</u>
2. Compliance Certificate	<u>Required</u>
Quantity Variation	<u>+/-10%</u>

Kindly note that all procurement through open tender will be done through e-procurement only in near future. Therefore all foreign and indigenous vendors participating through open tenders have to buy class-III DSC immediately issued by the certifying authorities in India.

PRE-QUALIFICATION TERM

P1.

Bidders should primarily be engaged in manufacturing and supply of material grade as required by BHEL in Name Plates. Bidders need to submit one or more purchase order(s) of cumulative value more than Rs. 10,000/- for the supply of similar items of any of its customer within last 3 years [i.e. Purchase(s) order placed on or after 01.05.2013].

SPECIAL TERMS

S1. Quotation Submission

Tenders in two part bids are invited from manufacturers for supply of Name Plates. Sealed tenders in two parts; Part-I: Techno-commercial bid and Part-II: Price bid are hereby invited for supply of 'Name Plates' as per tender enquiry. The relevant documents are attached with the Enquiry.



**SPECIAL TERMS AND CONDITIONS FOR
(Tender Enquiry No. 1617-015 Dated 03.05.2016 Due date 24.05.2016)
ITEM: Name Plates**

The two bids should be submitted in **separate sealed inner envelopes** duly mentioning the detail as follows:

Bid	Bid description	Superscribing on envelope	*** Should contain ***
Part I in First sealed envelope	Techno-Commercial Offer	Part-I (Techno-Commercial) bid against tender enquiry no:1617-015 dated 03.05.2016. Due Date of Opening 24.05.2016	1. Acceptance of all terms and conditions of tender enquiry. (Preferred is submitting signed copy of terms and conditions; if nothing is mentioned for any term, it shall be summarily concluded that the same is acceptable and no representation whatsoever shall be entertained later on).
			2. Un-priced bid as per format attached. All details, i.e. whether quoted for item, duties and taxes etc. should be filled.
Part II in Second sealed envelope	Price Bid	Part-II (Price) bid against tender enquiry No: 1617-015 dated 03.05.2016.	Price bid in the format attached.
			Anything other than prices mentioned in the price bid shall be considered invalid

Both/All the sealed envelopes should be put in outer sealed envelope superscribing all details i.e. Enquiry Number, Date, Supplier's Name and Address and Item.

S2. Counter offer

BHEL reserves the right to negotiate with L1 or re-float the tender in case the quoted prices are not acceptable. BHEL will not give counter-offer to vendors for this tender except MSE benefits mention in clause no. G12 of GCC of MM Tenders.

S3. Scope of Supply

Material shall be supplied as per the applicable latest Technical Delivery Conditions (TDC)/ Material Standard requirements/BPS/Drawing and other requirement as given in the Purchase Order. National & International material Standards shall have to be arranged by vendors themselves. **Comparison and procurement shall be done for Individual item, i.e. Name Plates where one bidder is found to L1, then for individual quantity PO will be released and bidders have to execute the order what so ever be the quantity and PO value.**

S4. General Contract Conditions (GCC)

These Special terms and conditions and GCC collectively are the part of tender terms and conditions.



BHEL GOINDWAL

SPECIAL TERMS AND CONDITIONS FOR
(Tender Enquiry No. 1617-015 Dated 03.05.2016 Due date 24.05.2016)
ITEM: Name Plates

CHECKLIST AND SEQUENCE OF DOCUMENTS TO BE SUBMITTED IN TWO PARTS BIDS

S. No.	Document	Status
1	Envelope should contain (1) Techno-Commercial bid (2) MSE Documents if any sealed in separate envelope superscribing tender enquiry detail, due date of opening, sender address	Sealed envelope marked as Part-I "Techno-Commercial Bids" Yes, Sealed
2	Price Bid sealed in separate envelope superscribing tender enquiry detail, due date of opening, sender address	Sealed envelope marked as Part-II "Price Bid" Yes, sealed
3	All two sealed envelopes put in an outer envelope mentioning all details like Enquiry no., description, due date	Yes



General Contract Conditions (GCC)
of
MM Tenders

Documents submitted with the offer shall be signed and stamped in each page by authorized representative of the bidder.

G1. INSTRUCTION TO BIDDER

Quotations shall be submitted before due date and time. Late offers are liable to be rejected, so please ensure to submit bid well within due date and time. Techno-commercial part will be opened on due date.

Based on evaluation of techno-commercial offers, Price bids of bidders who qualify from techno-commercial evaluation shall be opened. BHEL may decide to open the Price bid same day at 1700 hrs. If not opened on the same day, all qualifying bidders shall be notified for date of opening of Price bids by email/fax/post/courier.

Sealed Tenders can be dropped in the tender box labeled as 'Tender box for MM contracts'. This tender box is located at the entrance of Admin block BHEL Goindwal. Fax (01859-222061) / E-Mail (tendermm@bhelivp.in) offers received in time shall be considered only when such offers are complete in all respects.

In case of bulky tender please handover quotation to Sh Harpreet Rai/ DGM/Head-MM or Sh Tajinder Singh/AGM/HR,Civil,MM.

G2. INSTRUCTION TO BIDDER (In case of E-Procurement)

The bidder shall submit his response through bid submission to the tender on e-Procurement platform at <https://bheleps.buyjunction.in>

- The bidder would be required to register on the e-procurement market place <https://bheleps.buyjunction.in> and submit their bids online. **Sealed cover bids / e-Mails / FAX / Manual offer will NOT be accepted.**
- The bidder has to keep track of any changes by viewing the addendum / Corrigendum's issued by the Purchaser on time-to- time basis in the E-Procurement platform. The Company calling for tenders shall not be responsible for any claims/problems arising out of this.
- The user should complete all the processes and steps required for bid submission. The successful bid submission can be ascertained once acknowledgement is given by the system through bid submission number after completing all the processes and steps. BHEL and mjunction Services Ltd. will not be responsible for incomplete bid submission by users. Users may also note that the incomplete bids will not be saved by the system and are not available for the Purchaser for processing.

Before uploading scanned documents, the bidders should sign on all the statements, documents, certificates uploaded by him, owning responsibility for their correctness / authenticity. If nothing is mentioned it is assumed that all terms and conditions are acceptable. If supplier is mentioning his rates in units not asked by BHEL, BHEL has the right to reject/accept quotation.

Quotations shall be submitted before due date and time. Techno-commercial part will be opened on due date. BHEL may decide to open price bids of bidders who qualify from techno-commercial evaluation, on the same day at 1700 hrs. If not opened on the same day, all qualifying bidders shall be notified for date of opening of Price bids.

G3. PRICE BASIS

- a. CST, VAT & Excise duty + any cess on ED at the rates applicable shall be payable extra against ED Gate Pass valid for CENVAT benefit.
- b. Order of enquiry item sl. No. shall be maintained in the quotation.
- c. The rates quoted shall be firm and fixed. No price variation is proposed and allowed.
- d. Rates quoted should be F.O.R Goindwal basis. If bidder has quoted Ex Works, loading shall be done as per BHEL discretion for tender evaluation.

Variation in excise duty, sale tax/ vat or any other statutory levies during contractual delivery period shall be to BHEL's account



General Contract Conditions (GCC)
of
MM Tenders

G4. VALIDITY OF OFFERS:

The offers shall be kept open for acceptance 'for number of days mentioned in special terms and conditions' from the date of opening of the tender. In case of extension of tender opening date, the validity shall be suitably revised.

G5. SCOPE OF SUPPLY

Material shall be supplied as per the applicable latest Technical Delivery Conditions (TDC)/ Material Standard requirements/BPS/Drawing and other requirement as given in the Tender Enquiry. National & International material Standards shall have to be arranged by vendors themselves.

G6. REPLACEMENT OF REJECTION:

If the material is rejected due to defective workmanship during inspection or at the time of actual use, within the guarantee period (i.e. as per clause 13), the rejected material shall be replaced by the supplier. Corresponding quantity shall be treated as unsupplied against respective purchase order till replacement is received at BHEL. If the material is found defective and rejected during use for which payment has already been released the rejected quantity shall be supplied free of cost by the vendor within a month of intimation of the rejection by BHEL.

Lifting of rejected material is under Supplier's scope. BHEL will inform related invoice, qty etc to supplier. Supplier is expected to give the plan to lift and advance intimation when visiting to lift the material. Material should be lifted within one month from date of intimation. After one month BHEL will not be responsible for rejected material. BHEL may decide to send the rejected material on To Pay basis to supplier. Any leniency/ unresponsiveness/delay on part of supplier may lead to appropriate action by BHEL. Any request to postpone in written may be considered but replacement should not be linked with lifting of material.

G7. SUPPLIED MATERIAL ADJUSTMENT:

Item/s pending in previous PO has to be billed in previous PO only. Otherwise BHEL will be free to adjust the supplies in previous PO. Any implication of Excise, VAT etc will be on supplier's account. For this it is desirable to reconcile the pending PO statement every month/frequently. BHEL will give pending PO statement every month. This can also be viewed at Portal (<http://vis.bheltry.co.in/mm/index.jsp>).

G8. DELIVERY SCHEDULE:

Supplies shall be affected and completed as per schedule mentioned in special terms and conditions. **Further, BHEL may release delivery schedule from time to time based upon our requirement with mutual understanding.** Vendor shall be required to complete the order as per the BHEL schedule requested.

G9. ACCESS TO MANUFACTURING PREMISES:

While Purchase Orders placed on the vendor are under execution, authorized representatives of BHEL shall be allowed free access to the manufacturing facilities for the purpose of inspection or monitoring the progress of purchase orders. This access will also be extended to representatives of BHEL's customers accompanying the authorized representative/s of BHEL (which shall be intimated in advance), if our contractual requirements with our customers call for the same.

G10. TERMS OF PAYMENT:

- a. Due payment against supplies received shall be due after 30 days of receipt and acceptance of material and shall be paid within next 15 days period. In case of any deviation from standard payment term mentioned, BHEL at it's discretion may load on the item price at "Base rate of SBI (as applicable on the date of bid opening; Techno-commercial bid opening) + 6% shall be considered for loading for the period of relaxation sought by bidders.
- b. Documents to be submitted (if applicable)
 - i. Commercial invoice (in duplicate)



General Contract Conditions (GCC)
of
MM Tenders

- ii. Excise invoice (in duplicate) valid for claiming CENVAT credit
 - iii. Original VAT invoice valid for claiming input tax credit,
 - iv. Transporter copy along with material/consignment.
 - v. Material Test Certificates (MTC) and
 - vi. Compliance Certificate.
- c. Above documents should include your Registration numbers such as ECC no, PAN no, CST no, TIN/VAT nos. etc.
- d. If excise claim document is not received within time for claiming excise benefit as per restriction in availment of CENVAT Credit within 12 months of date of Invoice (Amendments in Union Budget 2015), the implication of this will be paid by supplier.
- e. It is mandatory to mention proper material codes in the invoices and separate invoices to be raised for different POs.
- f. ***BHEL releases payment through EFT mode ONLY. Necessary details may please be submitted by filling required format before release of payment.***

G11. INSPECTION:

- a. All required tests as called in referred material standard/BHEL/TDC/drawing etc shall be carried out by vendor at no extra cost. **BHEL may decide to inspect itself/arrange third party at vendors' works itself as and when necessary with prior intimation to the vendor.** No additional charges shall be claimed for such inspections.
- b. Third party inspection charges will be borne by BHEL. Moreover all required infrastructure (testing, tools etc) have to be arranged by supplier.
- c. **Vendor will give inspection call sufficiently in advance considering the delivery period stipulated in the purchase order.**
- d. Material Test Certificates (MTC), Inspection reports and Compliance/Guarantee Certificate are to be provided along with the supplies.
- e. Latest applicable revisions of standards/procedures to be referred. International/National standards are to be arranged by vendor.
- f. Any inspection carried out before supply by vendor/incoming stage at BHEL notwithstanding, if any defect/non-conformity is noted during processing, the same shall be attended/replaced by vendor at no extra cost.
- g. Necessary tooling including thread gauges etc have to be arranged by vendor. Only in exceptional cases, based on BHEL discretions item/nature, BHEL may consider request to provide gauges if available with BHEL. But in no case this shall be linked with delivery of material.

G12. PREFERENCES FOR MSE's:

Preferences as mentioned in "Public Procurement Policy for Micro and Small Enterprises (MSEs) Order, 2012" shall be given to Micro and Small enterprises.

Main points which are mentioned in the above order are as follows:

- 20% Procurement of the tender value shall be made from MSE (Micro, Small Enterprises) firms.
- 4% from the above mentioned 20% procurement quantity shall be procured from MSE's owned by SC /ST's. Failure to participate by any MSE owned by SC/ST's this 4% quantity shall be procured from other MSEs.
- EMD shall be exempted for MSE's. All these benefits are subject to production of all statutory documents
- In tender, participating Micro and Small Enterprises quoting price within price band of L1+15 per cent shall also be allowed to supply a portion of requirement by bringing down their price to L1 price in a situation where L1 price is from someone other than a Micro and Small Enterprise and such Micro and Small Enterprise shall be allowed to supply up to 20 per cent of total tendered value. In case of more



General Contract Conditions (GCC)
of
MM Tenders

than one such Micro and Small Enterprise, the supply shall be shared proportionately (to tendered quantity).

“MSE suppliers can avail the intended benefits only if they submit along with the offer, attested copies of either EM II certificate having deemed validity (five years from the date of issue of acknowledgement in EM II) or valid NSIC certificate or EM II certificate along with attested copy of a CA certificate (Format enclosed at Annexure -1 where deemed validity of EM II certificate of five years has expired) applicable for the relevant financial year (latest audited). Date to be reckoned for determining the deemed validity will be the date of bid opening (Part 1 in case of two part bid). Non submission of such documents will lead to consideration of their bid at par with other bidders. No benefit shall be applicable for this enquiry if any deficiency in the above required documents is not submitted before price bid opening. If the tender is to be submitted through e-procurement portal, then the above required documents are to be uploaded on the portal. Documents should be notarized or attested by a Gazetted officer.”

G13. GUARANTEE/WARRANTEE:

Vendor shall give a guarantee of 18 months from the date of dispatch or 12 months from date of receipt, against manufacturing defects, whichever is earlier. In case of non-acceptance of this term bid will be rejected.

G14. PENALTY FOR LATE DELIVERY:

‘Time is the essence of the contract’. As such, delivery of goods specified in the Purchase Orders released under the scope of this contract shall be made within the time limit prescribed therein. Penalty for late delivery will be applicable @ 0.5% per week or part thereof subject to a maximum of 10.0 %.

If any vendor does not accept LD ½% of the supply for each week of delay subject to a maximum of 5%, their offer is likely to be rejected by BHEL and the price bid shall not be opened. Bidders accepting for 10% LD shall not be loaded on account of LD. However bidders who offer any other % LD [between 5% to 10%] shall be loaded @ % deviation from 10% and their accepted %.e.g. If a bidder accepts for a max of 7% LD only, their offer would be loaded @ 3% (10 – 7 = 3).

BHEL reserves the right to receive or not receive the material after the due date of PO.

G15. RISK PURCHASE:

BHEL shall be entitled to terminate the contract/pending POs at any stage and to purchase elsewhere at the risk and cost of the vendor, either the whole of the goods or any part thereof which the supplier has failed to deliver or dispatch within the time stipulated as aforesaid. Vendor shall be liable for the losses, which BHEL may sustain by way of such risk purchase.

G16. SUB-CONTRACT:

The purchase order or any part thereof shall not be sub-contracted, assigned or otherwise transferred without previously obtaining the BHEL's consent in writing.

G17. FORCE MAJEURE:

If at any time during the continuance of the contract, the performance in which or in any part by either party of any obligations under the contract are prevented or delayed by reason of any war, hostilities, acts of public enemy, civil commotion, sabotage, fires, explosions, epidemics, quarantine restrictions, or acts of God (hereinafter referred to “an events” then provided the notice of happening of any such event is given by either party to the other within 21 days of the occurrence thereof, neither party shall by reason of such



General Contract Conditions (GCC)
of
MM Tenders

event be entitled to terminate the contract nor shall either party have any claim for damages against the other in respect of such non-performance and delay in performance and delivery under the contract shall be resumed as soon as practicable after such event has come to an end or ceased to exist. If the performance in whole or part of any obligation under the contract is prevented or delayed by reason of any such event, claims of extension of time shall be granted for periods considered reasonable by BHEL subject to prior notification by the vendor to BHEL of the particulars of the event and supply to BHEL, if required, of any supporting evidence. Any waiver of time in respect of partial installment shall not be deemed a waiver of time in respect of remaining deliveries.

G18. DISPUTES:

In the event of any dispute and/or difference arising between the Vendor and BHEL as to interpretation and/or execution of the contract and/or the respective rights and liabilities of the parties, such disputes and/or differences shall be referred to the sole arbitrator nominated by BHEL. The provisions of the Indian Arbitration Act and the rules there under shall apply to such arbitration. The award passed by the arbitrator shall be final and conclusively binding on all the parties.

G19. JURISDICTION:

The court of the place from where the purchase order is issued during the contractual period shall alone have jurisdiction to decide any dispute arising out of or in connection with the purchase order.

G20. CLARIFICATIONS

The correspondence exchanged against the tender from both tenderer and BHEL through email/e-procurement are considered as valid document legally though it is not signed. It is treated as valid confirmations made on behalf of the respective company and very much comes under the legal ambit of the business transaction and hence it is binding on both the parties to the business. Any transaction pertaining to the tender from both the parties of business done round the clock irrespective of the office or business hours of the companies, are valid legally and binding on both the parties. This applies to the extent only in such cases where deadline time for transaction is not specifically declared by either or both the parties to the business.

G21. LOI(Letter of Intent)

BHEL may issue LOI prior to the PO for any reason whatsoever. The LOI in such cases is to be treated as PO for all practical purposes and all the Terms & Conditions of the tender shall be applicable from the date of issue of LOI.

G22. WORDS AND FIGURES

- a. If, in the price structure quoted for the required goods/ services/ works, there is discrepancy between the unit price and the total price (which is obtained by multiplying the unit price by the quantity), the unit price shall prevail and the total price corrected accordingly, unless in the opinion of the purchaser there is an obvious misplacement of the decimal point in the unit price, in which case the total price as quoted shall govern and the unit price corrected accordingly.
- b. If there is an error in a total corresponding to the addition or subtraction of subtotals, the subtotals shall prevail and the total shall be corrected; and
- c. If there is a discrepancy between words and figures, the amount in words shall prevail, unless the amount expressed in words is related to an arithmetic error, in which case the amount in figures shall prevail subject of (a) and (b) above.
- d. If there is such discrepancy in an offer, the same shall be conveyed to the bidder with target date upto which the bidder has to send his acceptance on the above lines and if the bidder does not agree to the decision of the purchaser, the bid is liable to be ignored.

G23. GENERAL:

- a) BHEL will not be bound by any power of attorney granted by the vendors or by changes in the composition of the firm made subsequent to the execution of the contract. They may, however, recognize such power of attorney and changes after obtaining proper legal advice, the cost of which will be chargeable to the vendor concerned.
- b) BHEL reserves the right to extend the due date of opening, which shall be informed. Validity of offer shall be deemed to be revised accordingly.
- c) BHEL reserves the right to accept or reject any part or whole of the tender of a bidder by assigning a valid reason thereof. BHEL reserves the right to cancel the tender without assigning any reason thereof and without any obligation before any commitment.
- d) If possible, please submit soft copy of price quotation [copied on a blank CD of standard make] put in the sealed offer.
- e) Acceptance of all terms and conditions, in the form of signed copy of T&C or confirmation separately written, shall be submitted along with quotation. If nothing is mentioned, it shall be concluded that terms and conditions are acceptable.
- f) BHEL may increase/decrease item/s based on BHEL requirement before price bid opening. Suitable price implication may be asked from suppliers.
- g) BHEL may drop item/items from tender at any stage of tender before placing PO. BHEL may also delete PO with consent with supplier within delivery date of PO.
- h) After releasing PO, it is assumed that supplier has accepted PO if we do not receive acknowledgement from supplier within 5 days of date of PO.
- i) Any term is special tender terms and conditions will supersede the GCC.
- j) If advance tax is applicable at Punjab border. Supplier has to deposit this advance tax by himself which will be reimbursed on submission of documentary proofs (Copy of entry tax receipt/online transfer details duly verified).
- k) BHEL reserves the right to negotiate with L1 bidder/s.

G24. BANNED FIRMS:

The offers of the bidders who are on the banned list as also the offer of the bidders, who engage in the services of the banned firms, shall be rejected. The list of banned firms is available on BHEL website www.bhel.com.

G25. DISCLAIMER CLAUSE: (Only for E procurement)

Neither the Organization (Bharat Heavy Electricals Ltd.) nor the service provider (mjunction Services Ltd.) is responsible for any failure of submission of bids due to failure of internet or other connectivity problems or reasons thereof.

G26. FRAUD PREVENTION POLICY:

The Bidder along with its associate/collaborators/sub-contractors/sub-vendors/consultants/service providers shall strictly adhere to BHEL Fraud Prevention Policy displayed on BHEL website <http://www.bhel.com> and shall immediately bring to the notice of BHEL management about any fraud or suspected fraud as soon as it comes to their notice.

G27. REVERSE AUCTION:

“BHEL reserves the right to go for Reverse Auction (RA) instead of opening the sealed envelope price bid, submitted by the bidder. This will be decided after techno-commercial evaluation. All bidders to give their acceptance for participation in RA. Non-acceptance to participate in RA may result in non-consideration of their bids, in case BHEL decides to go for RA.

In case BHEL decides to go for Reverse Auction, only those bidders who have given their acceptance to participate in RA will be allowed to participate in the Reverse Auction. Those bidders who have given their acceptance to participate in Reverse Auction will have to necessarily submit “online sealed bid” in

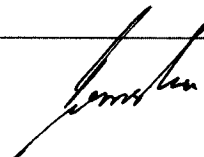



General Contract Conditions (GCC)
of
MM Tenders

the Reverse Auction. Non- submission of „online sealed bid“ by the bidder will be considered as tampering of the tender process and will invite action by BHEL as per extant guidelines in vogue.”

Terms & Conditions of Reverse Auction

Against this enquiry for the subject item/ system with detailed scope of supply as per enquiry specifications, BHEL may resort to “REVERSE AUCTION PROCEDURE” i.e., ON LINE BIDDING (THROUGH A SERVICE PROVIDER). The philosophy followed for reverse auction shall be English Reverse (No ties).

- a. For the proposed reverse auction, technically and commercially acceptable bidders only shall be eligible to participate.
- b. Those bidders who have given their acceptance for Reverse Auction (quoted against this tender enquiry) will have to necessarily submit “online sealed bid” in the Reverse Auction. Non-submission of „online sealed bid“ by the bidder for any of the eligible items for which techno- commercially qualified, will be considered as tampering of the tender process and will invite action by BHEL as per extant guidelines in vogue.
- c. BHEL will engage the services of a service provider who will provide all necessary training and assistance before commencement of on line bidding on internet.
- d. In case of reverse auction, BHEL will inform the bidders the details of Service Provider to enable them to contact & get trained.
- e. Business rules like event date, time, bid decrement, extension etc. also will be communicated through service provider for compliance.
- f. Bidders have to fax the Compliance form (annexure IV) before start of Reverse auction. Without this, the bidder will not be eligible to participate in the event.
- g. In line with the NIT terms, BHEL will provide the calculation sheet (e.g., EXCEL sheet) which will help to arrive at “Total Cost to BHEL” like Packing & forwarding charges, Taxes and Duties, Freight charges, Insurance, Service Tax for Services and loading factors (for non- compliance to BHEL standard Commercial terms & conditions) for each of the bidder to enable them to fill-in the price and keep it ready for keying in during the Auction.
- h. Reverse auction will be conducted on scheduled date & time.
- i. At the end of Reverse Auction event, the lowest bidder value will be known on auction portal.
- j. The lowest bidder has to fax/e-mail the duly signed and filled-in prescribed format for price breakup including that of line items, if required, (Annexure VII) as provided on case-to-case basis to Service provider within two working days of Auction without fail.
- k. In case BHEL decides not to go for Reverse Auction procedure for this tender enquiry, the Price bids and price impacts, if any, already submitted and available with BHEL shall be opened as per BHEL’s standard practice.
- l. Bidders shall be required to read the “Terms and Conditions” section of the auctions site of Service provider, using the Login IDs and passwords given to them by the service provider before reverse auction event. Bidders should acquaint themselves of the “Business Rules of Reverse Auction”, which will be communicated before the Reverse Auction.
- m. If the Bidder or any of his representatives are found to be involved in Price manipulation/ cartel formation of any kind, directly or indirectly by communicating with other bidders, action *as per extant BHEL guidelines*, shall be initiated by BHEL and the results of the RA scrapped/ aborted.
- n. The Bidder shall not divulge either his Bids or any other exclusive details of BHEL to any other party.
- o. In case BHEL decides to go for reverse auction, the H1 bidder (whose quote is highest in online sealed bid) may not be allowed to participate in further RA process.**

An abridged version of ‘Common Guidelines for conducting Reverse Auction’, has now been uploaded at ‘Supplier Registration’ page & ‘Tender Notifications’ page on BHEL website (www.bhel.com). Supplier can visit this page for more details on RA process.

Certificate by Chartered Accountant on letter head

This is to Certify that M/S ,
(hereinafter referred to as 'company') having its registered office at
..... is registered under MSMED Act 2006, (Entrepreneur
Memorandum No (Part-11) dtd:.....,
Category:..... (Micro/Small)). (Copy enclosed).

Further verified from the Books of Accounts that the investment of the company as per the latest audited financial year as per MSMED Act 2006 is as follows:

1. **For Manufacturing Enterprises:** Investment in plant and machinery (i.e. original cost excluding land and building and the items specified by the Ministry of Small Scale Industries vide its notification No.S.O.1722(E) dated October 5, 2006 :
Rs.....Lacs
2. **For Service Enterprises:** Investment in equipment (original cost excluding land and building and furniture, fittings and other items not directly related to the service rendered or as may be notified under the MSMED Act, 2006:
Rs.....Lacs

(Strike off whichever is not applicable)

The above investment of Rs.....Lacs is within permissible limit of Rs.....Lacs forMicro / Small (Strike off which is not applicable) Category under MSMED Act 2006.

Or

The company has been graduated from its original category {Micro/ Small} (Strike off which is not applicable) and the date of graduation of such enterprise from its original category is (dd/mm/yyyy) which is within the period of 3 years from the date of graduation of such enterprise from its original category as notified vide S.O. No.3322(E) dated 01.11.2013 published in the gazette notification dated 04.11.2013 by Ministry of MSME.

Date:
(Signature)

Name-

Membership number-
Seal of Chartered Accountant

**BHARAT HEAVY ELECTRICALS LTD
IVP, GOINDWAL SAHIB
UNPRICE BID ANNEXURE**

Annexure-II to Enquiry No. 1617-015 dated 03.05.2016 Due Date of submitting quotations 24.05.2016

Item : Name Plates

S.No	Material Code	Description of Material	Technical document no.	Tender qty	Unit	Quoted Yes/No
1	220746490000	NAME PL-1373	4V137304047/01	6000	NO	
2	964660630000	NAME PLATE	4VG00419240/00	300	NO	
3	220736490000	RATG.PL.WB180X108 BPS 017204	BPS 017204	400	NO	
4	220741280000	NM DIRECTION PLATE 20X75 BPS 017510	BPS 017510	2000	NO	
5	220745540000	CIR NAME PL20-BPS 017538	BPS 017538	200	NO	
6	220745640000	CIR NAME PL60-BPS 017538	BPS 017538	600	NO	
7	220745530000	CIR NAME PL16-BPS 017538	BPS 017538	800	NO	
8	220745620000	CIR NAME PL52-BPS 017538	BPS 017538	700	NO	
9	220747200000	CAUTION PL-MANUAL	BPS 017545	1000	NO	
10	220741660000	NAME PLATE 20X80-BPS:017522	BPS:017522	1100	NO	

Excise Duty rate + Cess Applicable (mention in % if applicable, mention as NIL if not applicable)	Please fill ED Applicable or Not applicable: _____
	If Applicable, Please specify whether it is inclusive or Extra : _____
	If Applicable, Please mention in %age : _____
CST (%) / VAT (%)	Please fill whichever is applicable i.e. CST or VAT: _____
	If Applicable, Please specify whether it is inclusive or Extra : _____
[wherever CST applicable, BHEL is Providing "C" form]	If Applicable, Please mention in %age : _____

The above prices are **Firm, without any price esclation; are Rs. Per Unit of measure; and are on FOR Goindwal Sahib basis.**

We accept all terms and conditions of the Tender Enquiry No. 1617-015 Dated 03.05.2016.

Authorised signatory with seal

BHARAT HEAVY ELECTRICALS LTD**IVP, GOINDWAL SAHIB****PRICE BID ANNEXURE**

Annexure-III to Enquiry No. 1617-015 dated 03.05.2016 Due Date of submitting quotations 24.05.2016

Item : Name Plates

S.No	Material Code	Description of material	Technical Document no.	Tender qty	Unit	Unit price, Rs	
						In Figures	In Numbers
1	220746490000	NAME PL-1373	4V137304047/01	6000	NO		
2	964660630000	NAME PLATE	4VG00419240/00	300	NO		
3	220736490000	RATG.PL.WB180X108 BPS 017204	BPS 017204	400	NO		
4	220741280000	NM DIRECTION PLATE 20X75 BPS 017510	BPS 017510	2000	NO		
5	220745540000	CIR NAME PL20-BPS 017538	BPS 017538	200	NO		
6	220745640000	CIR NAME PL60-BPS 017538	BPS 017538	600	NO		
7	220745530000	CIR NAME PL16-BPS 017538	BPS 017538	800	NO		
8	220745620000	CIR NAME PL52-BPS 017538	BPS 017538	700	NO		
9	220747200000	CAUTION PL-MANUAL	BPS 017545	1000	NO		
10	220741660000	NAME PLATE 20X80-BPS:017522	BPS:017522	1100	NO		

Taxes and other conditions will be as mentioned in Unprice Bids.

Authorised signatory with seal

ALL DIMENSIONS ARE IN MILLIMETRES.

FOR TOLERANCES OF UNTOLERANCED DIMENSIONS DURING MANUFACTURE REFER RELEVANT QCP/QP

REV 01	DATE 23.03.00	ALTERED K.P.LEON <i>John</i> CHD & APPD <i>Wb</i>
DIMENSION 80 WAS 75. DIMENSION 25 INTRODUCED. DIMENSION 35 WAS 30. TRIM SPACING INCREASED BY 5mm. REFER DCN:CS:1081		

SIZE OF LETTERS		~Wt./1000 in kg.
ENAMELLED	PUNCHED	
2.0	1.5	4.43

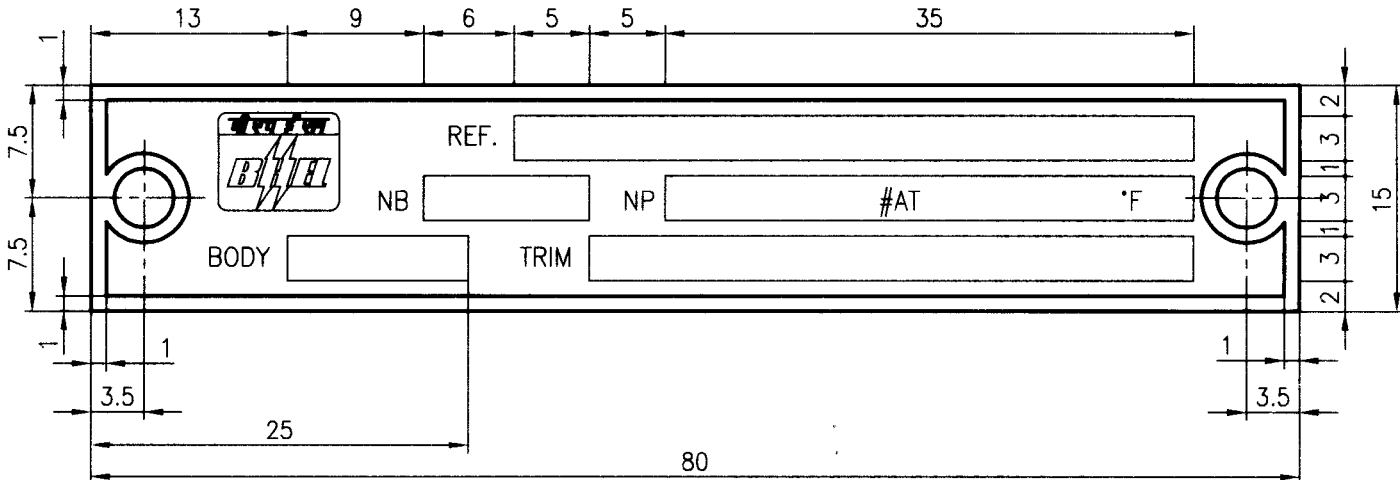

NOTES:

1. MATERIAL : 18/8 Cr.Ni. STEEL SHEET 0.5 mm THICK.
2. THE NAME PLATE SHALL HAVE RAISED BRIGHT POLISHED LETTERS. SPACES FOR DATA, EMBLEM AND BORDER ON ETCHED BLACK BACKGROUND.
3. THE MATERIAL OF WHICH THE BODY AND THE TRIM ARE MADE SHALL BE INDICATED BY CODES AS PER MSS-SP:25.
4. SCREW NAILS FOR FIXING NAME PLATES: SCREW NAILS SIZE 3 x 8 AS PER APPLICABLE STANDARDS.
5. THE NOMINAL BORE 'NB' WILL REPRESENT THE NOMINAL PIPE SIZE IN INCHES AND NOMINAL PRESSURE 'NP' WILL REPRESENT PRIMARY SERVICE PRESSURE IN (psig) AND CORRESPONDING SERVICE TEMPERATURE IN °F.
6. THE NAME PLATE SHALL BE CRACK-RESISTING SO THAT WHEN BENT THE ETCHING DOES NOT CRACK.
7. THE LOCATION OF THE NAME PLATE ON VALVES SHALL BE SPECIFIED BY THE DESIGNER.
8. AFTER FINALISING THE PURCHASE ORDER, SAMPLES OF THE NAME PLATE SHOULD BE TESTED IN THE LABORATORY FOR DURABILITY OF MATERIAL, ETCHING QUALITY ETC. BEFORE BULK SUPPLY IS EFFECTED.
9. THE EMBLEM SHALL BE BASED ON LATEST APPLICABLE STANDARDS.



-	-	-	-	-	-	-	-	-	-
NO OFF	DESCRIPTION	MATL CODE	MATL SPECN	HEAT TREATMENT	SCRAP SORT	NET WT (kg)	GROSS WT (kg)	DRAWING No	ITEM No



BHARAT HEAVY ELECTRICALS LTD.
 UNIT: HIGH PRESSURE BOILER PLANT.
 TIRUCHIRAPALLI 620014.

DRN	NAME K.P.LEON	SIGN <i>John</i>	DATE 23.03.2k	NO.OF VAR
CHD	T.R.R.MURTHY	<i>T.R.R.M</i>	23.03.2k	
APPD	K.S.RAMAN	<i>Wb</i>	23.03.2k	

DEPT VL	/	⊕	SCALE	WEIGHT (KG).	REFERENCE INFORMATIONS	NO. OF ITEMS
CODE 320			2:1	--	Component Code : 220746490000 CAD :C404047	

TITLE	CARD CODE	DRAWING NO.	REV
NAME PLATE FOR VALVES (SS)	U 01	4-V-1373-04047	01

CAUTION: The information on this document is the property of BHARAT HEAVY ELECTRICALS LTD. It must not be used directly or indirectly in any way detrimental to the interest of the company.

CAUTION: The information on this document is the property of BHARAT HEAVY ELECTRICALS LTD. It must not be used directly or indirectly in any way detrimental to the interest of the company.

FOR TOLERANCES OF UNTOLERANCED DIMENSIONS

ALL DIMENSIONS ARE IN MILLIMETRES.
DURING MANUFACTURE REFER RELEVANT QCP/QP

REV	DATE	ALTERED
		CHD & APPD

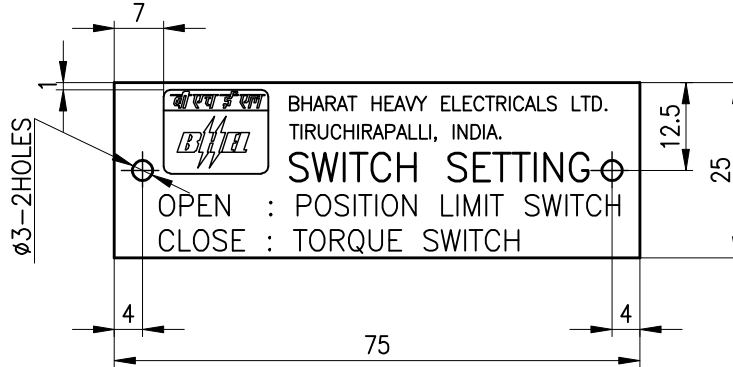

APPLICATION:

FOR ALL MOTOR OPERATED VALVES
EXCEPT 100mm & ABOVE 1500 CLASS AND ABOVE GATE VALVES

NOTES:

1. MATERIAL IS STAINLESS STEEL
2. THICKNESS OF THE PLATE 1mm
3. MONOGRAM SHALL BE BASED ON CORPORATE STANDARD No. AA0401120 REV.1
4. THE NAME PLATE SHALL BE CRACK RESISTING SO THAT WHEN BENT, THE PLATING DOES NOT CRACK
5. THE NAME PLATE SHALL HAVE RAISED BRIGHT WHITE LETTERS, EMBLEM ETC ON ETCHED BLACK BACKGROUND

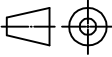
		96466063									
NO OFF	DESCRIPTION	MATL CODE	MATL SPECN	HEAT TREATMENT	SCRAP SORT	NET WT (kg)	GROSS WT (kg)	DRAWING No		ITEM No	
		BHARAT HEAVY ELECTRICALS LTD., UNIT: HIGH PRESSURE BOILER PLANT. TIRUCHIRAPALLI 620014.			DRN	NAME V.BAIRAVAN		SIGN	DATE 08.10.10	NO.OF VAR	
365-122					CHD	S.SATHEES			08.10.10		
					APPD	K.RAJASEKARAN			08.10.10		
DEPT VL		SCALE		WEIGHT (KG).		REFERENCE INFORMATION				NO. OF ITEMS	
CODE	320	 N.T.S									
TITLE					CARD CODE	DRAWING NO.				REV	
NAME PLATE (FOR CONVENTIONAL VALVES)					U 01	4-V-G004-19240					



PLANT STANDARD

HPBP TIRUCHIRAPPALLI

BPS 017204

Rev. No. 03

PAGE 1 OF 4

RATING PLATE-WALL DESLAGGER

0.0 SCOPE

This standard covers the requirements of Rating Plate for wall deslagger.

1.0 SPECIFICATION AND REFERENCE STANDARDS

Dimensions and preferred sizes	Fig.1 of this standard
Tolerance	Medium to IS: 2102
Material	CuSn37 HA, 1.6 mm thick acc. to IS 410
BHEL monogram	Acc. to corporate standard AA 040 1120
Lettering style	Acc. to corporate standard AA 042 1403
Finish	See clauses 2.0 to 2.5 of this standard
Technical delivery conditions	Acc. to corporate standard AA 085 1411

2.0 FINISH

2.1 All rating plates shall be manufactured by etching and shall meet the following technical and other requirements.

2.2 TOP PORTION: All letters of the name of the company and monogram with border shall be raised and bright nickel plated. The background shall be etched and finished black (stoving enamel).

2.3 MIDDLE PORTION:

2.3.1 The following details of this portion shall be raised and bright nickel plated.

Revisions

Brought upto date

Approved

STANDARDS SECTION
CONTRACT ENGINEERING AND CO-ORDINATION
HPBP, TIRUCHIRAPPALLI

Rev. No. 03

Amd. No.

Reaffirmed

Prepared

Issued

Dt of 1st Issue

Dt. 18.01.97

Dt.

Year

STANDARDS

STANDARDS

JAN. 1984



PLANT STANDARD

HPBP TIRUCHIRAPPALLI

BPS 017204

Rev. No. 03

PAGE 2 OF 4

- All letters of the name of the equipment.
- All 'pads' on which the rating particulars shall appear.

2.3.2 The following details of this portion shall be etched and finished black (stoving enamel).

- All letters, numerals etc. of the rating details appearing on the pads.
- All the dividing lines separating the pads from each other.
- Remaining area in the background

2.4 BOTTOM PORTION: All letters shall be raised and bright nickel plated. Remaining area in the background shall be etched and finished black (stoving enamel).

2.5 Border around the rating plate and the two dividing lines shall be raised and bright nickel plated.

3.0 DESIGNATION

A rating plate of size 180 mm length and 108 mm width to this standard shall be designated as :

3.1 On drawings

- a) Description column : RATG PL-WB 180x108
- b) Drawing number column : BPS 017204
- c) Material spec. column : Brass
- d) Material code column : 22 073 649

3.2 Ordering description

For placing indents, issuing enquiries and on purchase orders, ordering description given below shall be followed.

Rating plate - wall deslagger to BPS 017204



PLANT STANDARD

HPBP TIRUCHIRAPPALLI

BPS 017204

Rev. No. 03

PAGE 3 OF 4

4.0 ADDITIONAL INFORMATION

4.1 Copies of the following standards shall be enclosed along with purchase order.

a) BPS 017 204

b) AA 040 1120

c) AA 042 1403

d) AA 085 1411

4.2 Material code shall be painted at the back of each piece.

4.3 The figure shown is for illustration only and supplier has to submit drawings to actual size for approval before effecting bulk supplies.



PLANT STANDARD

HPBP TIRUCHIRAPPALLI

BPS 017204

Rev. No. 03

PAGE 4 OF 4

FIG. 1

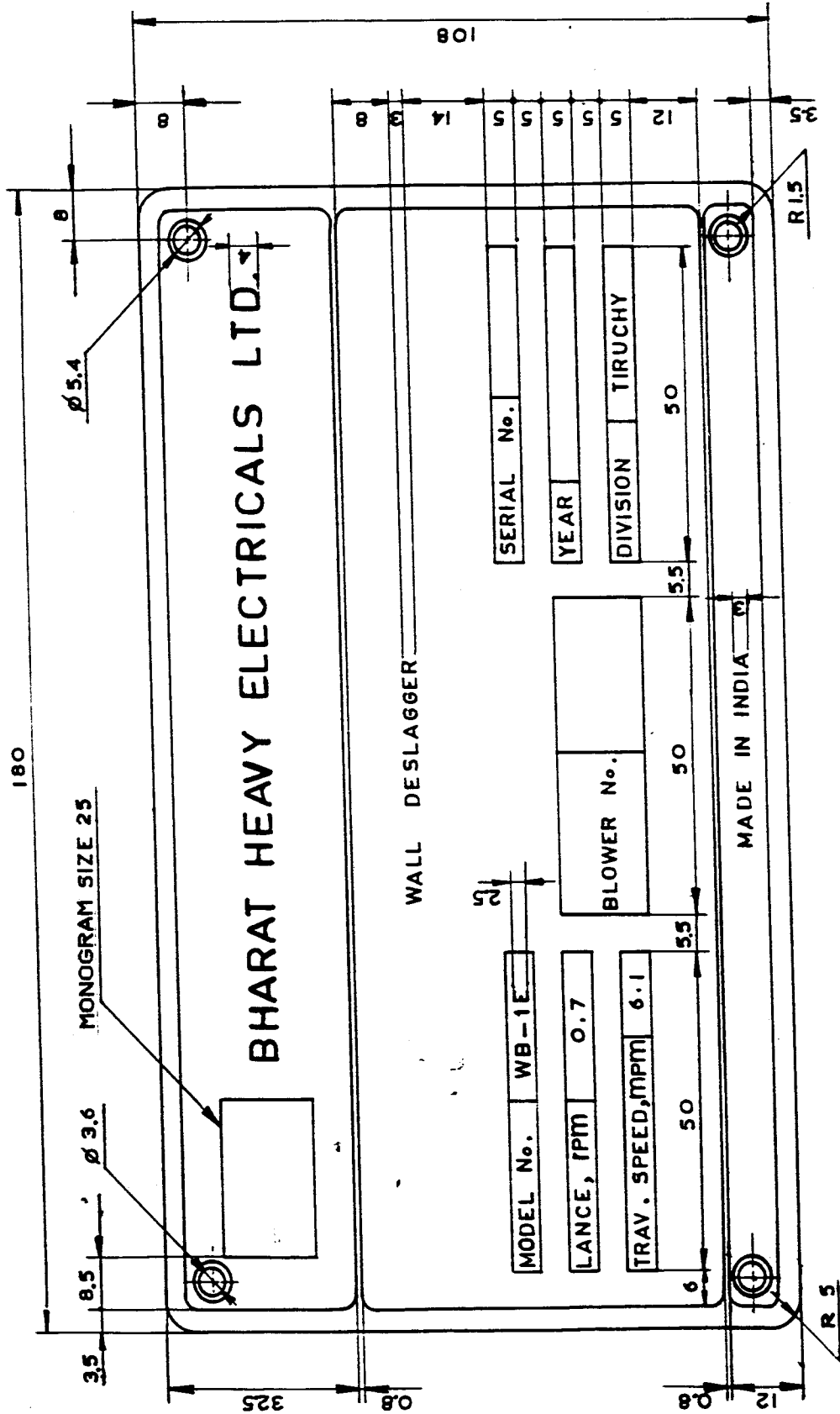



PLANT STANDARD

HPBP TIRUCHIRAPALLI

BPS : 017510

PAGE 1 OF 3

DIRECTION PLATE (STRAIGHT DIRECTION INDICATOR)

1 SCOPE

- 1.1 This standard stipulates the requirements of the Direction plate to be put on the equipments/products of BHEL.
- 1.2 This standard supersedes the earlier version of BPS: 017510

2 DESIGNATION

- 2.1 A straight direction plate B x L = 20x75 shall be designated as:

Straight direction plate 20x75 - BPS: 017510

2.1.1 On design documents:

- i) Description column: NPL DTN PLATE 20x75
- ii) Drawing No. column: 017510 2075
- iii) Material specn column: Brass
- iv) Material code column : 22 074 128

- 2.2 On indents: Direction plate (Straight direction indicator-BPS: 017510)

- 2.3 On purchase orders/enquiries: While issuing enquiries/purchase orders a copy of this standard shall be enclosed

3 COMPLIANCE WITH STANDARDS

3.1 Dimensions

- 3.1.1 Direction plate and arrow sizes etc shall be as shown in the figure and Table 1.

- 3.2 Material: Cold rolled brass sheet grade CuZn37, 1/4Hard t IS: 410.

REVISIONS

DATE

APPROVED

STANDARDS SECTION
ENGINEERING AND DEVELOPMENT CENTRE
HPBP TIRUCHIRAPALLI

PREPARED

HPBP TIRUCHY

ISSUED

EDC/Standards

DATE

20.08.84



PLANT STANDARD

HPBP TIRUCHIRAPALLI

BPS: 017510

PAGE 2 OF 3

3.3 Finish: Arrow and border shall be raised and bright nickel plated, followed by chromium plating according to IS: 4827. The thickness of nickel plating shall be 20 microns minimum and the chromium plating 0.3 microns minimum.

4 TEST REQUIREMENTS

4.1 Before finalising the purchase order the samples of the plate shall be procured and humidity test, resistant to salt spray test conducted according to corporate standard AA 040 12 02.

4.2 Accelerated weather proof test

4.2.1 The paint should not show any sign of deterioration when subjected to accelerated weathering test of 21 days in accordance with clause A4 of IS: 2932.

5 FIXING HOLES AND SCREWS

5.1 Dimensions of fixing holes, size etc shall be as shown in Figure. Screw size shall be as shown in Table 1.

6 MARKING AND PACKING

6.1 BPS code 017510 2075 and material code (22 074 128) shall be painted at the back of each direction plate.

6.2 Each direction plate should be suitably packed in polythene cover (500 microns thickness) so as to avoid any damage to the finish during transit/storing.

7 NOTE

7.1 The background of arrow shall be etched and finished black. The depth of etching shall be 100 to 500 microns.

7.2 Weight is calculated on the basis that brass weighs 8.6 kg/dm³.

7.3 Sharp edges shall be rounded off and burrs removed.



PLANT STANDARD

HPBP TIRUCHIRAPALLI

BPS: 017510

PAGE 3 OF 3

The information on this document is the property of BHARAT HEAVY ELECTRICALS LIMITED. It must not be used directly or indirectly in any way detrimental to the interest of the company.

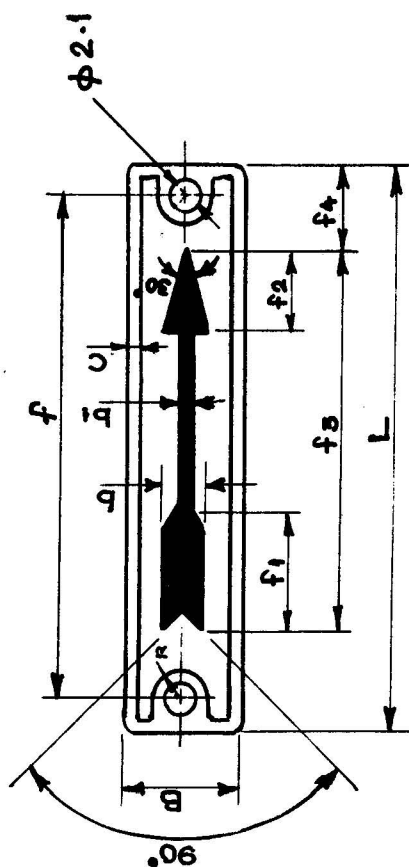

TABLE : 1. (ALL DIMENSIONS IN MILLIMETRES)

L	B	f ₁	f ₂	f ₃	f ₄	f	b	b ₁	R	C	THICK NESS OF PLATE	NORMAL SIZE OF SCREEN	≈ WEIGHT/1000 IN KG.
75	20	15	10	45	15	67	15	5	4	2	1	0 (2x6)	12.9



PLANT STANDARD

HPBP TIRUCHIRAPPALLI

BPS 017538

64

Rev. No. 01

PAGE 1 OF 3

CIRCULAR NAME PLATE FOR VALVES

0.0 SCOPE

This standard covers the requirements of Circular name plate for valves.

1.0 SPECIFICATION AND REFERENCE STANDARDS

Dimensions and preferred sizes	Fig.1 and table 1 of this standard
Tolerance	Medium to IS: 2102
Material	Aluminium sheet of thickness 1 mm
Lettering style	According to corporate standard AA 042 1403
Finish	See clause 2.1 of this standard
Technical delivery conditions	Acc. to clause 3.0 to 3.3.2 of this standard

2.0 FINISH

2.1 Name plates shall be hard anodized according to IS:6057 incorporating matter, letters and border in blue colour with white background.

3.0 TECHNICAL REQUIREMENTS

3.1 GENERAL

3.1.1 The surface shall be free of cracks, blisters and damages. Sharp edges shall be rounded off.

3.1.2 Samples of the name plates shall be obtained and tested in the laboratory for durability of the material, anodizing and weather proofness before bulk supply is effected.

3.2 MARKING. Back side of each name plate shall be marked with material code given by BHEL and with manufacturer's identification.

Revisions

Brought upto date

Approved

STANDARDS SECTION
CONTRACT ENGINEERING AND CO-ORDINATION
HPBP, TIRUCHIRAPPALLI

Rev. No. 01

Amd. No.

Reaffirmed

Prepared

Issued

Dt of 1st Issue

Dt. 18.01.97

Dt.

Year

STANDARDS

STANDARDS

MAR 1986



PLANT STANDARD

HPBP TIRUCHIRAPPALLI

BPS 017538

65

Rev. No. 01

PAGE 2 OF 3

3.3 PACKING.

3.3.1 Before packing, each name plate shall be applied with transparent synthetic adhesive film.

3.3.2 Each name plate shall be suitably packed in polythene cover (500 microns thickness minimum) in order to avoid any damage to the surface during transit/storage etc.

4.0 DESIGNATION

A circular name plate for valve of size 24 to this standard shall be designated as :

4.1 On drawings

a) Description column : NPL CIR VALVE 24

b) Drawing number column : BPS 017538 0024

c) Material spec. column : Aluminium

d) Material code column : 22 074 555

4.2 Ordering description

For placing indents, issuing enquiries and on purchase orders, ordering description given below shall be followed.

Circular name plate for valves, size 24 to BPS 017538

5.0 ADDITIONAL INFORMATION

5.1 Copies of the following standards shall be enclosed along with purchase order.

a) BPS 017 538

b) AA 042 1403

5.2 The figure shown is for illustration only and supplier has to submit drawings to actual size for approval before effecting bulk supplies,



PLANT STANDARD

HPBP TIRUCHIRAPPALLI

BPS 017538

66

Rev. No. 01

PAGE 3 OF 3

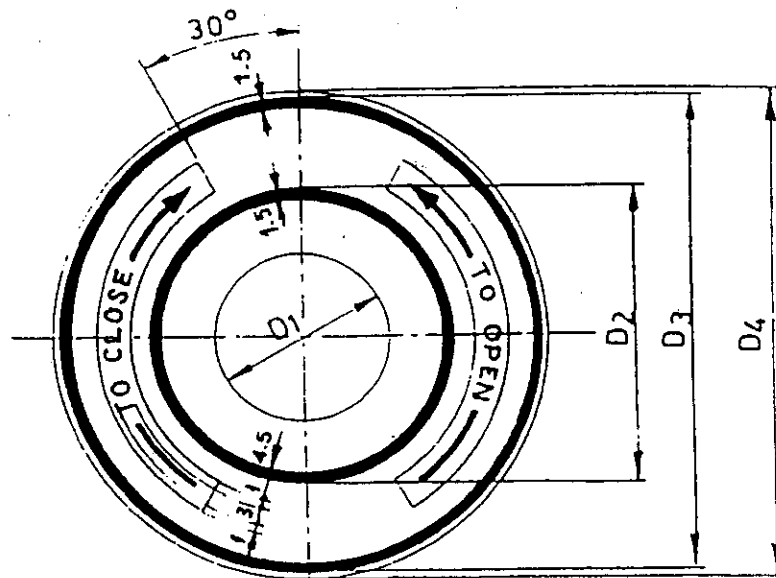

Figure 1

TABLE 1

(All dimensions in millimetres)

Nomi- nal size	D ₁	D ₂	D ₃	D ₄	Corresponding size of hand- wheel retain- ing nut	wt/1000 pieces in.kg
6	6.4	34	60	62	M6	7.47
8	8.4	34	60	62	M8	7.41
10	10.5	34	60	62	M10	7.33
12	13.0	34	60	62	M12	7.22
16	17.0	34	60	62	M16	6.98
20	21.0	39	65	67	M20	7.95
24	25.0	44	70	72	M24	3.95
27	28.0	49	75	77	M27	10.10
30	31.0	56	82	84	M30	11.97
36	37.0	61	87	89	M36	12.87
39	40.0	66	92	94	M39	14.21
42	43.0	71	97	99	M42	15.61
45	46.0	71	97	99	M45	15.09
52	54.0	81	107	109	M52	17.60
56	58.0	81	107	109	M56	16.72
60	62.0	106	132	134	M60	27.71
64	66.0	92	118	120	M64	19.72





PLANT STANDARD

HPBP TIRUCHIRAPPALLI

BPS 017545

Rev. No. 02

PAGE 01 OF 03

CAUTION PLATE (FOR MANUAL OPERATION)

0.0 SCOPE

This standard covers the requirements of Caution Plate for manual operation.

1.0 SPECIFICATION AND REFERENCE STANDARDS

Dimensions and preferred sizes Fig.1 of this standard

Material CuSn37 HA, 0.5mm thick acc. to IS 410

Lettering style Acc. to corporate standard AA 042 1403

Finish See clause 2.1 to 2.2 of this standard

Technical delivery conditions Acc. to corporate standard AA 085 1411

2.0 FINISH

2.1 All caution plates shall be manufactured by etching and shall meet the technical delivery conditions.

2.2 All letters of the caution plate and border shall be raised and bright nickel plated. The back ground shall be etched and finished black (stoving enamel).

Revisions
BROUGHT UPTO DATE

Approved
STANDARDS SECTION
CONTRACT ENGINEERING AND CO-ORDINATION
HPBP, TIRUCHIRAPPALLI

Rev. No. 02

Amd. No.

Reaffirmed

Prepared

Issued

Dt of 1st Issue

Dt. 04.10.97

Dt.

Year

STANDARDS

STANDARDS

AUG 1984



PLANT STANDARD

HPBP TIRUCHIRAPPALLI

BPS 017545

Rev. No. 02

PAGE 02 OF 03

3.0 DESIGNATION (typical case)

A caution plate of size 20 mm width and 80 mm length to this standard shall be designated as:

3.1 On drawings

- a) Description column : CAUTION PL MANUAL
- b) Drawing number column : BPS 017545
- c) Material spec. column : Brass
- d) Material code column : 22 074 720

3.2 Ordering description

For placing indents, issuing enquiries and on purchase orders, ordering description given below shall be followed.

Caution plate of size 20 x 80 to BPS: 017545

4.0 ADDITIONAL INFORMATION

4.1 Copies of the following standards shall be enclosed along with purchase order.

- a) BPS 017 545
- b) AA 042 1403
- c) AA 085 1411

4.2 Material code shall be painted at the back of each piece.

4.3 Supplier has to submit drawings to actual size for approval before effecting bulk supplies.



PLANT STANDARD

HPBP TIRUCHIRAPPALLI

BPS 017545

Rev. No. 02

PAGE 03 OF 03

CAUTION PLATE

(FOR MANUAL OPERATION)

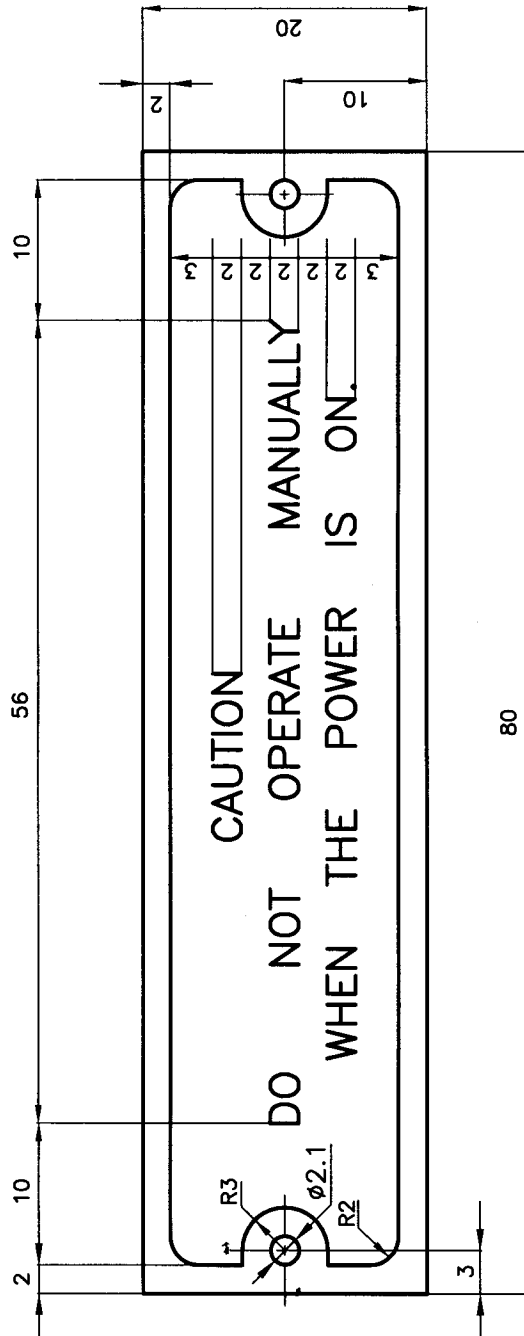

(ALL DIMENSIONS IN MILLIMETRES)

FIG:1



PLANT STANDARD

HPBP TIRUCHIRAPPALLI

BPS 017522

Rev. No. 02

PAGE 1 OF 3

NAME PLATE FOR VALVES

0.0 SCOPE

This standard covers the requirements of Name Plate for valves.

1.0 SPECIFICATION AND REFERENCE STANDARDS

Dimensions and preferred sizes	Fig.1 and table 1 of this standard
Tolerance	Medium to IS: 2102
Material	Aluminium sheet of thickness 0.5 mm
BHEL Monogram	According to corporate standard AA 040 1120
Lettering style	Acc. to corporate standard AA 042 1403
Finish	See clause 2.1 of this standard
Technical delivery conditions	Acc. to clause 3.0 to 3.3.2 of this standard

2.0 FINISH

2.1 The Name plate shall be hard anodized according to IS: 6057 incorporating the matter as shown in the figure 1. The letters, space for data, BHEL monogram and border shall be finished bright white with black background.

3.0 TECHNICAL REQUIREMENTS

3.1 GENERAL

3.1.1 The surface shall be free of cracks, blisters and damages. Sharp edges shall be rounded off.

3.1.2 Samples of the name plate shall be obtained and tested in the laboratory for durability of the material, anodizing and weather proofness before bulk supply is effected.

Revisions

Brought upto date

Approved

STANDARDS SECTION -
CONTRACT ENGINEERING AND CO-ORDINATION
HPBP, TIRUCHIRAPPALLI

Rev. No. 02	Amd. No.	Reaffirmed	Prepared	Issued	Dt of 1st Issue
Dt. 18-1-'97	Dt. -	Year	STANDARDS	STANDARDS	AUG 1984

COPYRIGHT AND CONFIDENTIAL
The information on this document is the property of BIHARAT HEAVY ELECTRICALS LIMITED. It must not be used directly or indirectly in any way detrimental to the interest of the company.



PLANT STANDARD

HPSP TIRUCHIRAPPALLI

BPS 017522

Rev.No. 02

PAGE 2 OF 3

3.2 MARKING. Back side of each name plate shall be marked with material code given by BHEL and with manufacturer's identification.

3.3 PACKING.

3.3.1 Before packing, each name plate shall be applied with transparent synthetic adhesive film.

3.3.2 Each name plate shall be suitably packed in polythene cover (500 microns thickness minimum) in order to avoid any damage to the surface during transit/storage etc.

4.0 DESIGNATION

A Name plate for valve of size 15x55 to this standard shall be designated as :

4.1 On drawings

- | | |
|--------------------------|---------------------|
| a) Description column | : NPL VALVES 15x55 |
| b) Drawing number column | : BPS 017522 1555 |
| c) Material spec. column | : Aluminium |
| d) Material code column | : <u>22 074 165</u> |

4.2 Ordering description

For placing indents, issuing enquiries and on purchase orders, ordering description given below shall be followed.

Name plate for valves of size 15x55 to BPS 017522

5.0 ADDITIONAL INFORMATION

5.1 Copies of the following standards shall be enclosed along with purchase order.

- a) BPS 017 522
- b) AA 040 1120
- c) AA 042 1403

5.2 The figure shown is for illustration only and supplier has to submit drawings to actual size for approval before effecting bulk supplies.

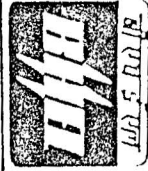

PLANT STANDARD

HPBP TIRUCHIRAPPALLI

BPS 017522

Rev. No. 02

PAGE 3 OF 3

FIG. 1

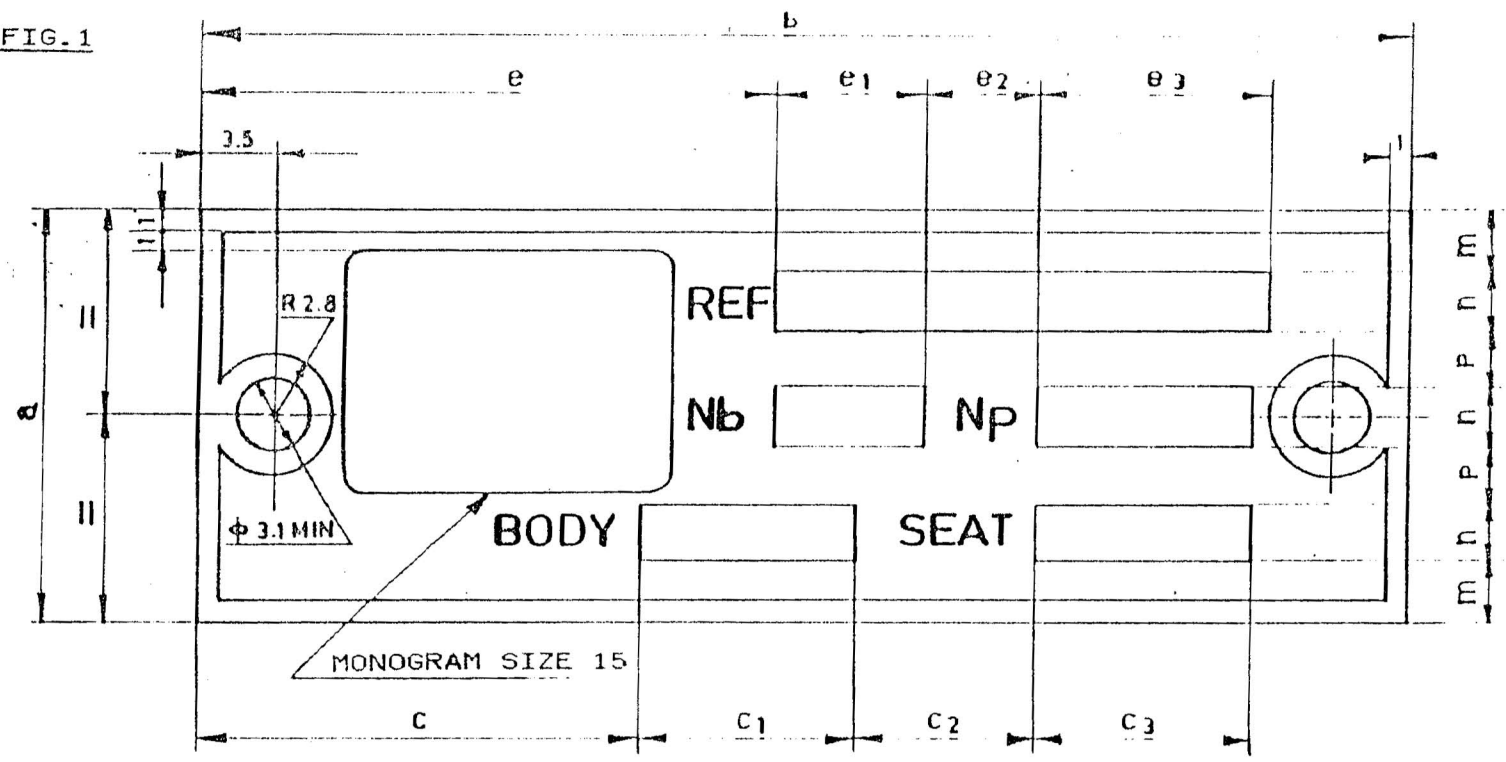

TABLE:1 (ALL DIMENSIONS IN MILLIMETRES)

SIZE a x b	c	c ₁	c ₂	c ₃	e	e ₁	e ₂	e ₃	m	n	p	ENAMELLED	PUNCHED	≈ WEIGHT/ 1000 IN KG
												2	1.5	
20 X 80	23	20	10	20	33	12	8	20.7	3	4	1	2	2	2.16
15 X 55	20	10	8	10	26	7	5	10.7	2	3	1	2	1.5	1.12