

  <p>ISO 9001, ISO 14001, OHSAS 18001 &SA8000 Certified Company</p> <p>SubContract and Purchase Department.</p>	<p>भारत हेवी इलेक्ट्रिकल्स लिमिटेड (भारत सरकार का उपक्रम) BHARAT HEAVY ELECTRICALS LIMITED (A Govt. of India Undertaking) पावर सेक्टर, उ.क्षे.परिसर, प्लाट नं.25, सेक्टर-16ए, पोस्ट बॉक्स सं.55,नोएडा-201301, Power Sector-Northern Region, Plot no.25, Sector 16 A, Noida -201301 Ph : 0120-2416500/2416262 , Fax: 0120-2416528 / 2416525</p>
---	---

TENDER ENQUIRY NO: BHEL/PSNR/SCP/SS/ E-2661

DATE: 11.06.2015

TENDER ENQUIRY SUPPLY, INSTALLATION & COMMISSIONING OF HYDRAULIC DYNAMIC BRAKING SYSTEM WITH OTHER COMPONENTS

BHEL Power Sector, Northern Region invites sealed quotation from **supplier** in **two part bid system** for the following item required at GUMMA SHEP (2X1.5 MW), CHIRGAON, SHIMLA (H.P) as follow:

SL. No	Enquiry No.	DESCRIPTION	LAST DATE OF TENDER SUBMISSION & OPENING	DELIVERY SCHEDULE
1A	BHEL/PSNR/S CP/ SS/ E-2661	Supply of Hydraulic Dynamic Braking System with other components	25.06.2015 SUBMISSION TIME: 15.00 Hrs. OPENING TIME: 15.30 Hrs.	WITHIN 08-10 WEEKS FROM THE DATE OF APPROVAL OF QAP & DRAWINGS.
1B		Installation & commissioning of Hydraulic Dynamic Braking System		

DESTINATION FOR SUPPLY IS AS FOLLOWS:

Astt. Engineer,Electrical Mtc. Sub-division,Gumma Power House,HPSEB, Chirgaon,Distt: Shimla-171208 (H.P.)

QUALIFYING REQUIREMENTS / PAST EXPERIENCE:-

- 1) Bidder/ Supplier who wish to participate should have supplied Hydraulic Braking System for Horizontal Shaft Hydro Turbine Unit of any rating within India or outside in past 5 years from the date of technical bid opening.

Supporting documents i.e. P.O. Copy along with Performance Certificate should be provided to meet above Qualifying Criteria.

- 2) (i) **Average annual TURNOVER** in last three Financial Years (FY) shall be at least **4..80 Lacs.**
(ii) Bidder must have earned **CASH PROFIT** in any one of the last three (03) FY.

Bidder to submit audited Balance Sheet and Profit & Loss Account of the company for last 3 Financial Years (FY) in support to Sl. No. I), & II) as above.

Note:

- In case annual accounts of last FY are not audited, then bidder should submit the audited annual accounts of previous three FY.
- In case audited annual accounts have not been submitted for all the three years as indicated above, then the applicable audited annual accounts as submitted by the bidder against the requisite three years will be averaged for three years.

NOTES:-

The Tender Document comprise of following;

- a. ANNEXURE - 1 (TECHNICAL SPECIFICATIONS)
- b. ANNEXURE - 2 (IMPORTANT NOTES)
- c. ANNEXURE - 3 (SPECIAL TERMS & CONDITIONS)
- d. ANNEXURE - 4 (GENERAL TERMS & CONDITIONS)
- e. ANNEXURE - 5 (UNPRICE FORMAT)
- f. ANNEXURE – 6 (PRICE SCHEDULE For Hydraulic Dynamic Braking System with other components)
- g. ANNEXURE - 7 (CERTIFICATE FOR NO DEVIATION)
- h. ANNEXURE - 8 (REVERSE AUCTION FORMAT AND TERMS & CONDITIONS)
- i. ANNEXURE - 9 (PBG FORMAT)
- j. ANNEXURE - 10 (LIST OF CONSORTIUM BANK)
- k. ANNEXURE - 11 (CERTIFICATE OF CHARTERED ACCOUNTANT)
- l. ANNEXURE-12 (GENERALISED UNDERSTANDING OF JOB)
- m. ANNEXURE- 13 (DRAWINGS)

Technical Specifications of item Hydraulic Dynamic Braking System with other components

Sl. No.	SPECIFICATION		VENDOR'S CONFIRMATION*
1.	Qty. Required :	One set	
B	Unit specifications		
1	At present, rotor stalling time during coasting down is significantly high. This system is required to quick stop the shaft during coasting down to prevent unnecessary wear & tear.		
2	Unit rated RPM is 1500 RPM.		
3	The outer diameter of Flywheel is 1000 mm at Gumma Power House.		
4	Moment of Inertia, GD2 of generator is 540 Kilogram-square meters.		
C	Technical Specifications		
1	Braking Speed	Unit runs at 1500 RPM. System should apply brakes between 150-200 RPM only in coasting down.	
2	Brake Pads	Brake Pads should be of non-brittle & non-asbestos type material and have to be designed for applying at flywheel area. The outer diameter of Flywheel is 1000 mm at Gumma Power House.	
3	Installation	Rigid grouting should be casted for holding the brakes fixture.	
4	Brakes application	Brakes should apply simultaneously without fail as failure of application of any one brake may lead to generate unbalanced radial force which may damage bearings.	
5	Stalling Time	After brakes application, rotor should stall within 5 minutes.	
6	Operating Requirement	AUTO' Operation & 'MANUAL' operation both are required. 2 control points should be given- Control room and floor area.	
7	Status Indication	Indication for 'Brakes ON' and 'Brakes OFF' should be incorporated.	
8	Alarm Indication	Alarm for non-healthiness of system should be incorporated.	
9	Technical literature, catalogues	Necessary detailed technical literature, catalogues, write ups, references etc. shall be submitted along with offer.	
10	RECOMMENDED SPARES	List of recommended spares for five years of operation along with item wise price shall be submitted with the offer	
11	GUARANTEE:	The complete equipment shall be guaranteed for trouble free operation at site for 12 months from the date of commissioning or 18 months from the date of dispatch whichever is earlier.	

***Note:** Vendor to give their confirmation for each row as above.

IMPORTANT NOTES

1. Bidders not offering the material as per specification described in Annexure – 1 shall not be considered.
2. All corrigenda, addenda, amendments and clarifications to this Tender will be hosted in the web page (www.bhel.com) and not in the newspaper. Bidders shall keep themselves updated with all such amendments.
3. BHEL reserves the right to split, accepts or rejects any or all tenders without assigning any reason what so ever.
4. BHEL takes no responsibility for any delay/loss of documents or correspondences sent by courier/post.
5. Sealed tenders in two part bid system i.e. Part-I – Techno-Commercial bid and Part-II - Price bid are invited for **"Supply Installation & commissioning of Hydraulic Dynamic Braking System with other components" as indicated above under technical specification sheet (Annexure-1)** as per detailed specifications in Annexure-1, so as to reach us before the date of opening. The tenders (Part I only) will be opened at **15.30 PM (IST) on 25.06.2015**.
Note: In case the due date of opening of tender becomes a non-working day, then the due date & time of offer submission and opening of tenders get extended to the next working day.

6. Tender should not be addressed to any Individual's name but only by designation to:

**Sr. ENGINEER/ PURCHASE
BHARAT HEAVY ELECTRICALS LIMITED
POWER SECTOR-NORTHERN REGION,
HRDI & ESI COMPLEX, PLOT NO.25, SECTOR 16 A,
NOIDA –201301 (INDIA)**

7. TENDERS TO BE SUBMITTED IN TWO PARTS:

Part:I: Techno-commercial bid containing technical details along with commercial offer containing the following;

- (i) Covering letter/Offer forwarding letter of Tenderer.
- (ii) Supporting documents against Qualifying Requirements (QR) and vendor confirmation regarding technical specification.
- (iii) Duly filled-in 'No Deviation Certificate' as per Annexure -7.
- (iv) Quality Assurance Plan (QAP) & Drawings

Note:

- a) In case of any deviation, the same should be submitted separately for technical & commercial parts, indicating respective clauses of tender against which deviation is taken by bidder. It shall be specifically noted that deviation recorded elsewhere shall not be entertained.
- b) BHEL reserves the right to accept/reject the deviations without assigning any reasons, and BHEL decision is final and binding. In case of unacceptable deviations, BHEL reserves the right to reject the tender
- (iv) Acceptance to commercial terms and conditions by submitting duly signed and stamped all pages of Tender document as a proof of acceptance.
- (v) All Amendments/Correspondences/Corrigenda/Clarifications/Changes/ Errata etc. pertinent to this NIT.
- (vi) Bidders shall submit their offer in INR only, the same to be indicated in their offer (Part-I).
- (vii) Commercial: This part shall include / indicate the following:
(a) Station of dispatch (b) Taxes & duties applicable (c) Delivery Schedule
- (viii) Copy of **"Un-Priced Format as per Annexure - 5"** i.e., without the price details to be enclosed with clearly mentioning that whether **QUOTED or NOT APPLICABLE (NA). (No hidden charges shall be accepted)**.

(ix) Any other details preferred by bidder with proper indexing.

PART: II: PRICE BID AS PER ANNEXURE –6 (in separate envelope duly indicating the item tender no. & date), DULY FILLED, SIGNED AND STAMPED. IT SHOULD INCLUDE FOLLOWING:

- (i) Offered price (as per Price Schedule format enclosed).
- (ii) The bidders should fully understand scope of supply and their responsibilities under the tender specifications before quoting. The bidders are required to quote only in Indian Currency for the rates as per rate schedule, in part-II price bid. Conditional price bid or price bid with any deviation are liable to be rejected. No cutting / erasing /overwriting shall be done in the price bid.

Note: Bidder may ensure to sign each page of the tender document / their offer while submitting techno - commercial offer/ price-bid.

8. Following should be super scribed on the envelopes of the two parts of the Bid.

Part I: Techno-Commercial Bid:-

Tender for: _____

Tender No. _____ Due on: _____

Part II: PRICE BID: (to be submitted separately clearly superscribed and sealed):

Tender for: _____

Tender No. _____

9. BOTH PART-I & PART-II SHOULD BE INDIVIDUALLY SEALED & SUPERSCRIBED AS INDICATED ABOVE & SHALL BE ENCLOSED IN ONE MAIN ENVELOPE DULY SEALED & SUPERSRIBED AS:

Tender for: _____

Tender No. _____ Due on: _____

Containing Part I and Part II of the offer

The tenders should be sent sufficiently in advance so as to reach before the due date and time. BHEL shall not be responsible in case of delay in receipt of tenders.

10. LANGUAGE & CORRECTIONS

- a) The Tenderer shall quote the rates in Hindi/English language and international numerals only. The rates shall be entered in figures as well as in words. For the purpose of tender, the metric system of units shall be used.
- b) All entries in the tender shall either be typed or written legibly in ink. Erasement and over-writings are not permitted and may render such tenders liable for rejection.
- c) Tenderer's offer, remarks and deviations, shall be with reference to sections and clause numbers given in the tender documents.
- d) All cancellations and insertions shall be duly attested by the tenderer.
- e) All columns for price format shall be filled. If not applicable, please write "NA".

11. TENDER EVALUATION

The Purchaser will examine the bids to determine whether they are complete, whether any computational errors have been made, whether required sureties have been furnished, whether the documents have been properly signed and whether the bids are generally in order.

12. PRICE DISCREPANCY

- a) Totals/Gross Total of Prices should be indicated both in words as well as in figures. If there is a discrepancy between unit prices, total price quoted in words and figures, the Arithmetical errors will be rectified on the following basis.
 - a. If there is a discrepancy between the unit price and the total price, which is obtained by multiplying the unit price and quantity, or between subtotals and the total price, the unit or subtotal price shall prevail, and the total price shall be corrected.
 - b. If there is a discrepancy between words and figures, the amount in words shall prevail.
- b) In case of any other discrepancy, the decision of the purchaser will be final.

SPECIAL TERMS AND CONDITION

1. Unloading of material at destination shall be in BHEL's scope.
2. Price in INR should be quoted for **F.O.R destination** as per “**Destination for supply**”.
3. **EVALUATION CRITERIA:** Tender will be evaluated based on net cost to BHEL after considering Cenvat credit (if applicable), as indicated in Unprice Bid & Price Bid (Annexure-5 & 6) of Tender.
4. **TAXES AND DUTIES:**

SERVICE PORTION

- 4.1 The contractor shall pay all (save the specific exclusions as enumerated in this contract) taxes, fees, license charges, deposits, duties, tools, royalty, commissions or other charges which may be levied on the input goods & services consumed and output goods & services delivered in course of his operations in executing the contract. In case BHEL is forced to pay any of such taxes, BHEL shall have the right to recover the same from his bills or otherwise as deemed fit.

However, provisions regarding Service Tax and Value Added Tax (VAT) on output services and goods shall be as per following clauses.

4.2 Service Tax & Cess on Service Tax

- 4.2.1 Service Tax and Cess on Service Tax as applicable on output Services are excluded from contractor's scope; therefore contractor's price/rates shall be exclusive of Service Tax and Cess on Output Services.

- 4.2.2 Contractor shall obtain prior written consent of BHEL before billing the amount towards such taxes. The Service Tax Rules permit more than one option or methodology for discharging the liability of tax/levy/duty and BHEL will have the right to adopt the appropriate one considering the amount of tax liability on BHEL/Client as well as procedural simplicity with regard to assessment of the liability. The option chosen by BHEL shall be binding on the Contractor for discharging the obligation of BHEL in respect of the tax liability to the Contractor. Contractor shall submit to BHEL documentary evidence of Service Tax registration certificate specifying name of services covered under this contract.

- 4.2.3 For the purpose of claiming any Service Tax from BHEL, the following procedure shall be adopted :

- 4.2.3.1 Contractor shall submit serially numbered Service Tax and Cess Invoices, signed by him or a person authorized by him in respect of taxable service provided, and shall contain the following, namely:

- 4.2.3.1.1 The name, address and registration number of the contractor
- 4.2.3.1.2 The name and address of the party receiving taxable service (BHEL)
- 4.2.3.1.3 Description, classification and value of taxable service provided and
- 4.2.3.1.4 The Service Tax payable thereon.

- 4.2.4 All the four conditions shall be fulfilled in the invoice for payment of Service Tax by BHEL. Where more than one nature of Service under Service Tax Rules is involved, the invoice mentioned above shall contain the break up of all values for each nature of Service.

Purpose of above requirements, interlia, is to enable availment of CENVAT credit by BHEL. As per recent amendment in Service tax Act, time restrictions for taking CENVAT credit are within 12 months from the date of Invoice. Wherever CENVAT

credit could not be availed by BHEL within statutory time line of 12 months due to delay in submission of invoices or for any other reasons attributable to vendors/contractors, liability towards loss of such CENVAT credit shall be passed on to vendors/contractors.

- 4.2.5 Name and address of the contractor should be same in the service tax invoice and monthly bill. Any change in the name and address in past should be supported by documentary evidence duly certified by the registering authority.

4.3 VAT (Sales Tax /WCT)

- 4.3.1 The rates quoted by the Contractor shall be inclusive of VAT/Sales Tax and BHEL shall not reimburse any amount on this account due to any reason whatsoever.
- 4.3.2 The Contractor shall register himself with the respective Sales Tax authorities of the state and submit proof of such registration to BHEL along with the first RA bill. Deduction of tax at source shall be made as per the provisions of law unless otherwise found exempted.

Note: Applicability of the above clause shall be as per law of the state.

Contractor has to make his own arrangement at his cost for completing the formalities, if required, with Sales Tax/VAT Authorities, for bringing all their material, plant and equipment etc at site for the execution of the work, including arrangement of Road Permits if and as applicable under the relevant VAT Act.

4.4 Modalities of Tax Incidence on BHEL

- 4.4.1 Wherever the relevant tax laws permit more than one option or methodology for discharging the liability of tax/levy/duty, BHEL will have the right to adopt the appropriate one considering the amount of tax liability on BHEL/Client as well as procedural simplicity with regard to assessment of the liability. The option chosen by BHEL shall be binding on the Contractor for discharging the obligation of BHEL in respect of the tax liability to the Contractor.

4.5 New Taxes/Levies

- 4.5.1 In case the Government imposes any new levy/tax on the output service/goods/work after award of the contract, the same shall be reimbursed by BHEL at actual.
- 4.5.2 In case any new tax/levy/duty etc. becomes applicable after the date of Bidder's offer, the Bidder/Contractor must convey its impact on his price duly substantiated by documentary evidence in support of the same before opening of Price Bid. Claim for any such impact after opening the Price Bid will not be considered by BHEL for reimbursement of tax or reassessment of offer.
- 4.5.3 No reimbursement/recovery on account of increase/reduction in the rate of taxes, levies, duties etc. on input goods/services/work shall be made. Such impact shall be taken care of by the Price Variation/Adjustment Clause (PVC) if any. In case PVC is not applicable for the contract, Bidder has to make his own assessment of the impact of future variation if any, in rates of taxes/duties/ levies etc. in his price bid.

4.6 TAXES & DUTIES (SUPPLY PORTION)

- 4.6.1 Price quoted should be inclusive of all the applicable charges, taxes and duties, including entry tax. However rates of sales tax, excise duty & other statutory

levies should be indicated separately. Variation in excise duty, sales tax/ VAT or any other statutory levies during contractual delivery period should be to BHEL's account. In case of material purchased within the state, VAT shall be payable only if submission of VAT invoices/ documentary evidence by the vendor. In case of outside state purchase, BHEL shall issue C-Form & road permit, if required.

5. **INSPECTION:** The supplier shall offer the Hydraulic Dynamic Braking System with other components for inspection demo/demonstration of the equipment at works (Pre-dispatch Inspection & Demonstration). Supplier has to prepare Manufacturing Quality Plan (MQP). Inspection shall be carried out jointly by team of BHEL Engineers. Expenses towards Travelling / Boarding and Lodging of visiting inspection Engineer shall be to BHEL Account. However all testing arrangements shall be to supplier. Supplier has to intimate (at least 10 days in prior and in writing) for inspection of above material at their works. However if there is any delay in inspection by BHEL, the same will be on BHEL's account. However, final Physical inspection of the items shall be done on receipt of items at destination.

6. **Delivery:** The delivery for all the Hydraulic Dynamic Braking System shall be **within 8-10 weeks** from the date of approval of QAP & Drawings. **LR/ GR/ RR date for indigenous supplies shall be treated as the date of dispatch for levying LD. In case delivery period quoted by the bidder is not in line the tender requirement, then BHEL may reject their offer.** Bidders to note the following:

- (i) Scanned copy of P.O. shall be emailed.
- (ii) Demonstration of the product shall be carried out at supplier works, during pre-dispatch inspection.
- (iii) Road Permit shall be issued by respective BHEL Region (destination), where equipment is to be delivered.
- (iv) **Commissioning Schedule: 15 days after receipt of material at site.**

Transportation & Insurance shall be in supplier's scope. Supplier shall arrange comprehensive Insurance for transit & site erection period.

Bidders are requested to arrange the transporters and dispatch the goods on our behalf on freight (including transit insurance) pre-paid basis. Goods to reach at destination within reasonable time say 10 days.

Documents required with dispatch:

- a) **Factory setting certificate**
- b) **Warranty Certificate**
- c) **Installation, Operation & Maintenance manuals including drawings-4 hard copies**
- d) **Packing list-2 Nos. hard copies**
- e) **All other soft copies shall be available in one CD and supplier shall submit 4 nos CD's.**

7. **VALIDITY OF OFFER:** Offers should be valid for a **period of 90 days from the** date of Techno-Commercial bid (Part-I) opening.

8. **SCOPE OF WORK:**

- a. Pre-dispatch Inspection & Demonstration of Hydraulic Dynamic Braking System shall be carried out at supplier's works before despatch.
- b. Supply of Hydraulic Dynamic Braking System to site & quantities as mentioned in page no.2 of tender.
- c. Installation & Commissioning of supplied Hydraulic Dynamic Braking System. Arrangement of manpower, T&Ps, all consumables i.e. cement, gravels, plates, bars etc. to be arranged by the vendor

9. Calibration Certificates (if applicable) & Warranty certificate for the above items shall be provided along with dispatch of material.
10. Service support of the equipment under purchase is of utmost concern. Tenderers shall elaborate on the service network and spare parts availability, which are to be ensured to maintain the equipment after initial commissioning and completion of warranty period. In case service/spare parts facilities are not available in India, tenderers shall indicate the maximum possible time in making such services available from places outside India.
11. The tenderers shall also provide free visits of their service engineer from manufacturer's works / service centers for attending the faults during the warranty period in case of any complaint by the end user.
12. The equipment being offered should be of robust design and suitable for operations in Indian climatic conditions. The electrical and controls should be tropicalized to withstand such climatic conditions.
13. **Payment Terms:** Tenderer shall adhere to the following payment terms:-

a) FOR SUPPLY:

- 75 % payment on receipt of material at site
- 25 % on successful Installation & Commissioning of Hydraulic DBS.

b) FOR INSTALLATION & COMMISSIONING:

- 100 % payment after completion of successful Installation & Commissioning of Hydraulic Dynamic Braking System.

The set of dispatch documents for payment shall be as follows:-

- 1) Original tax Invoices
- 2) Copy of LR/ Packing List
- 3) Warranty Certificate for the goods.
- 4) Calibration Certificates, if applicable
- 5) Original copy of SRVs.
- 6) Certificate confirming, "Goods supplied are new".

A bank guarantee equal to **10% of the Order value excluding taxes & duties** valid up to 18 months from date of supply, shall be submitted at the time of claiming 25% final payment as per SI no. (b) above.

NOTES:-

- (i) Tenderers are required to specifically confirm acceptance of these payment terms in their techno-commercial offer.
- (ii) **No advance shall be paid.**

14. **PAYING AUTHORITY:**

BHEL-RSC, ADVANT OFFICE, NOIDA

15. **Warranty:**

The offered shall carry a warranty for a period of 18 months from date of dispatch of material at site. Rectification / replacement required during the warranty period will be arranged by the supplier free of cost including to and fro transport charges and import duty/excise duty/other taxes/insurance etc. payable on replacement items.

Supplier to submit the Performance Bank Guarantee (PBG) equivalent to **10% of the Order value excluding taxes & duties** which shall be valid up to 18 months from date of supply.

16. No enhancement of Price, whatsoever the cause, will be allowed once the offer is accepted and the order is placed. Withdrawal of the offer after it is accepted or failure to make the supply within the schedule period will entail cancellation of purchase order.
17. The quantity of item to be purchased may vary according to actual requirement at the time of placement of order.
18. Any Bidder falling under MSE category, shall furnish the following details & submit documentary evidence/ Govt. Certificate etc. in support of the same along with their Techno-commercial offer

Type under MSE	SC/ST owned	Others
Micro		
Small		

Note: - If the bidder does not furnish the above, offer shall be processed construing that the bidder is not falling under MSE category.

MSE suppliers can avail the intended benefits only if they submit along with offer, attested copies of either EM II (Entrepreneur Memorandum II) certificate having deemed validity (Two years from the date of issue of acknowledgement in EM-II) or valid NSIC certificate or EM-II certificate along with CA certificate (Format enclosed as per Annexure- 11) applicable for the year, certifying quantum of investment in plant and machinery within the permissible limit as per the act for relevant status (Micro and Small) where the deemed validity of EM-II is over. Date to be reckoned for determining the deemed validity will be the last date of technical bid submission. Non submission of such documents will lead to consideration of their bids at par with other bidders and MSE status of such suppliers shall be shifted to Non MSE supplier till the supplier submits these documents.

MSEs shall be exempted from payment of earnest money at the time of tender deposit. However, there is no exemption of security deposit submission.

No benefit shall be applicable for that particular enquiry if the required documents are not submitted before price bid opening.

19. REVERSE AUCTION:

BHEL reserves the right to go for Reverse Auction (RA) instead of opening the sealed envelope price bid, submitted by the bidder. This will be decided after techno-commercial evaluation. All bidders to give their acceptance for participation in RA. Non-acceptance to participate in RA may result in non-consideration of their bids, in case BHEL decides to go for RA.

In case BHEL decides to go for Reverse Auction, only those bidders who have given their acceptance to participate in RA will be allowed to participate in the Reverse Auction. Those bidders who have given their acceptance to participate in Reverse Auction will have to necessarily submit „online sealed bid“ in the Reverse Auction. Non-submission of „online sealed bid“ by the bidder will be considered as tampering of the tender process and will invite action by BHEL as per extant guidelines in vogue. **For details please refer to Annexure – 8.**

20. In case of contradiction / conflict the order of precedence shall be in the order as mentioned below:

- a. Amendments/Clarifications/Corrigenda/Errata etc., if any, issued in respect of the tender documents by BHEL.
- b. Price Schedule (Annexure-6)
- c. Technical Specifications (Annexure-1)
- d. Special Terms & Conditions (Annexure-3)
- e. Tender Notice (Pages 1-2)
- f. Important Notes (Annexure-2)
- g. General Terms & Conditions (Annexure- 4)

ANNEXURE-"4"

GENERAL TERMS & CONDITIONS

1. Manufacturer's name, their trade mark and brand, if any should invariably be mentioned in the tender and illustrative leaflets in duplicate giving technical particulars etc. should be attached to the tender, to facilitate consideration of the offer.
2. Materials should be of best quality and correct to specifications, relevant DIN/ISO/ANSI standard or any other equivalent INTERNATIONAL standard specification as per technical specifications of tender.
3. Correct date of affecting supplies in the event of an order from this office should be recorded in the tender.
4. Please note that our terms of payment are as per clause 13 of "SPECIAL TERMS AND CONDITIONS". All payments shall be done through Electronic Funds Transfer supplier shall submit bank details with bill invoices .In case of payment through, Bank all incidental charges will be to the Beneficiary's account.
5. Bharat Heavy Electricals Limited does not bind itself to accept the lowest tender, but reserves to itself the right to accept or reject all or part of any tender at its discretion.
6. No enhancement of rate, whatsoever the cause, will be allowed once the offer is accepted and the order is placed. Withdrawal of the offer after it is accepted or failure to make the supply within the schedule period will entail cancellation of purchase order and purchase at the risk and cost of supplier.
7. The quantities of each item to be purchased may vary according to actual requirement at the time of placement of order.
8. Where Sales Tax is payable extra, it will only be paid if registration numbers both under local sales tax/VAT and Central Sales Tax are specifically mentioned on the invoice. Tenderers should invariably quote their sales tax Registration No. in the offer.
9. **Liquidated Damages:** The LD shall be 0.5% of the total order value per week of delay or part thereof subject to a maximum of 10% of the total order value.
In case of any amendment/revision, the LD shall be linked to the amended/revised PO value.
10. **Risk Purchase:** - Alternatively, the purchaser at his option, will be entitled to terminate the contract and to purchase elsewhere at the risk and cost of the seller either the whole or any part of the goods which the supplier fails to deliver or dispatch within the time stipulated as aforesaid, or if the same were not available, the best and the nearest available substitute therefore. The seller shall be liable for any loss, which the purchaser may sustain by reason of such risk purchase in addition to L.D. at the rate mentioned in clause 9 above.
11. **Inspection:** All goods and work are subject to our inspection either at manufacture's works or after delivery as may be agreed. The decision of BHEL shall be final. Rejected goods will be returned to the supplier at his cost including freight on original shipment.
12. **Insurance:** - Wherever specifically agreed to, the supplier will insure at his cost the goods for all transit risks. In all other cases, supplier must furnish particulars of dispatch i.e. station of dispatch and destination, name of the goods, number of cases and their weights, value of the goods including all taxes, duties, levies and freight etc. for each consignment immediately after

the dispatch of goods. Failure to do this will make the supplier responsible for making good any loss which might have otherwise been recovered from insurers.

Note: However, the supplier shall still remain responsible for defective parts or short supply and defective packing.

13. **Metric System:** - Suppliers are requested to give metric measurements while quoting.
14. **Force majeure:** The following shall amount to Force Majeure;
14.1) Acts of God, act of any Government, War, Sabotage, Riots, Civil commotion, Police action, Revolution, Flood, Fire, Cyclones, Earth quake and Epidemic and other similar causes over which the seller has no control.
14.2) If the seller suffers delay in the due execution of the contractual obligation due to delays Caused by force majeure as defined above, the agreed time of completion of the job covered by this contract or the obligations of the supplier shall be extended by a period of time equal to period of delay, provided that on the occurrence of any such contingency, the supplier immediately reports to BHEL in writing the causes of delay and the seller shall not be eligible for any compensation.
15. **Arbitration & Reconciliation:-**
15.1) In case amicable settlement is not reached in the event of any dispute or difference arising out of the execution of the Contract or the respective rights and liabilities of the parties or in relation to interpretation of any provision by the supplier in any manner touching upon the Contract, such dispute or difference shall (except as to any matters, the decision of which is specifically provided for therein) be referred to the sole arbitration of the arbitrator appointed by BHEL/In Charge (Region).

The award of the Arbitrator shall be binding upon the parties to the dispute

Subject as aforesaid, the provisions of Arbitration and Reconciliation Act 1996 (India) or statutory modifications or re-enactments thereof and the rules made there under and for the time being in force shall apply to the arbitration proceedings under this clause. The venue of the arbitration shall be the place from which the contract is issued or such other place as the Arbitrator at his discretion may determine.

15.2) In case of Contract with Public Sector Enterprise (PSE) or a Government Department, the following shall be applicable:

In the event of any dispute or difference relating to the interpretation and application of the provisions of the Contract, such dispute or difference shall be referred to by either party to the arbitration of one of the arbitrators in the department of public enterprises. The award of the arbitrator shall be binding upon the parties to the dispute, provided, however, any party aggrieved by such award may make further reference for setting aside or revision of the award to the Law Secretary, Department of Legal Affairs, Ministry of Law and Justice, Government of India. Upon such reference the dispute shall be decided by the Law Secretary or the Special Secretary or Additional Secretary when so authorized by the Law Secretary, whose decision shall bind the parties hereto finally and conclusively.

15.3) The cost of arbitration shall be borne equally by the parties.

15.4) Stores under the contract shall be continued during the arbitration proceedings Any suites in respect of this contract shall have the jurisdiction of the courts of New Delhi (India) only.

ANNEXURE-“5”

UNPRICE FORMAT (TO BE SUBMITTED WITH TECHNICAL BID)

Sl.No.	DESCRIPTION	REMARKS
1	SUPPLY:	
1.1	Supply OF Hydraulic Dynamic Braking System with other components. AS PER SPECIFICATION ENCLOSED IN ANNEXURE-1 of NIT. (01 set)	QUOTED IN PRICE BID
1.2	PACKING AND FORWARDING CHARGES	QUOTED IN PRICE BID
1.3	EXCISE DUTY & CESS/CVD (IF APPLICABLE AS PER CL 4 OF STC)	QUOTED IN PRICE BID RATE OF DUTY.....
1.4	Sales Tax WITH “C” FORM	QUOTED IN PRICE BID RATE OF TAX.....
1.5	VALUE ADDED TAX (VAT) @ % RATE	QUOTED IN PRICE BID RATE OF TAX.....
1.6	OTHER TAXES, IF ANY TO BE SPECIFIED (_____)	QUOTED IN PRICE BID RATE OF TAX.....
1.7	TRANSPORTATION / FREIGHT CHARGES & TRANSIT INSURANCE CHARGES FROM MANUFACTURER / AUTHORIZED DEALER WORK PLACE TO BHEL OFFICE, AS PER BELOW: Asth. Engineer,Electrical Mtc. Sub-division,Gumma Power House,HPSEB, Chirgaon,Distt: Shimla-171208 (H.P.)	QUOTED IN PRICE BID
1.8	TOTAL SUPPLY ORDER VALUE ON F.O.R DESTINATION BASIS	QUOTED IN PRICE BID
1.9	- LESS VAT FOR SUPPLIES MADE FROM HIMACHAL PRADESH (HP) AGAINST VAT INVOICE , IF APPLICABLE (AS PER SL. NO 1.5)	QUOTED IN PRICE BID
1.10	NET COST TO BHEL (SUM OF Sl. Nos.1.8+(-) 1.9)	QUOTED IN PRICE BID
2	INSTALLATION & COMMISSIONING:	
2.1	Installation & commissioning FOR Hydraulic Dynamic Braking System with other components at destination. AS PER SPECIFICATION ENCLOSED IN ANNEXURE-1 of NIT. (THIS ALSO INCLUDES CHARGES OF VENDORS’ ENGINEER, BOARDING & LODGING CHARGES AND ALL OTHER CHARGES)	QUOTED IN PRICE BID
2.2	SERVICE TAX	QUOTESD IN PRICE BID
2.3	TOTAL CHARGES FOR INSTALLATION & COMMISSIONING	QUOTED IN PRICE BID
2.4	CENVAT CREDIT BENEFIT TO BHEL (AS PER CL 4 OF STC)	QUOTED IN PRICE BID
2.5	NET COST (FOR INSTALLATION & COMMISSIONING) TO BHEL AFTER CONSIDERING CENVAT CREDIT (SL. NO. 2.3 – SL. NO. 2.4)	QUOTED IN PRICE BID
2.6	TOTAL PRICE FOR SUPPLY & DEMONTRATION OF Hydraulic Dynamic Braking System with other components (SL. NO. 1.8+ SL. NO. 2.3) – FOR ORDERING PURPOSE	AGREED
2.7	NET COST TO BHEL FOR SUPPLY & DEMONTRATION OF Hydraulic Dynamic Braking System with other components (SL. NO. 1.10+ SL. NO. 2.5) – FOR TENDER EVALUATION PURPOSE	AGREED
7	SUBMISSION OF PBG AS PER NIT	AGREED
8	WARRANTY/GUARANTEE AS PER NIT	AGREED
9	PAYMENT TERMS AS PER NIT	AGREED
10	DELIVERY PERIOD AS PER NIT	AGREED
11	VALIDITY OF OFFER AS PER NIT	AGREED

NOTES:

1. Tenders will be evaluated based on “NET COST TO BHEL for SUPPLY & DEMONTRATION OF Hydraulic Dynamic Braking System with other components” (Sl. No. 2.7).
2. Bidders are requested to quote for each and every item as indicated above. Please indicate NIL against items not applicable. Incomplete offer received may not be considered.

3. The Rate shall be entered in figures as well as in words. In case of difference in rates between words and figures THE LESSER OF THE TWO will be treated as valid rate.
4. In case of omission in quoting any rate, the evaluation will be done considering the highest quoted rate obtained against that item but the order, if placed, will be on the lowest quoted rate obtained against that item.
5. Bidders are requested to arrange the transporter and dispatch the goods on our behalf on freight (Including transit insurance) pre-paid basis. Goods to reach at destination within reasonable time say 10 days.
6. Any other Central Govt. /State Govt. taxes, Levies applicable, if not specified above, shall be reimbursed as per actual on submission of documentary proof from the concerned Govt. office.
7. **Two Separate Purchase Orders (POs) Shall Be Issued For Supply Of Hydraulic Dynamic Braking System with other components and Installation & Commissioning of Hydraulic Dynamic Braking System with other components.**
8. **For Central Sales Tax purposes, BHEL - PSNR, NOIDA shall provide C- Form to the respective bidder/supplier after despatches.**

(Signatures of the Bidder with Name, Designation & Company's Seal)

ANNEXURE-“6”**PRICE SCHEDULE FOR ITEM 1A (TO BE SUBMITTED WITH PRICE BID)**

SL. NO.	DESCRIPTION	QUANTITY	UNIT RATE (Rs.)	AMOUNT (Rs.)
		A	B	C = AXB
1	SUPPLY:			
1.1	Supply OF Hydraulic Dynamic Braking System with other components. AS PER SPECIFICATION ENCLOSED IN ANNEXURE-1 of NIT. (01 set)	01		
1.2	PACKING AND FORWARDING CHARGES	01		
1.3	EXCISE DUTY & CESS/CVD (IF APPLICABLE AS PER CL 4 OF STC)	01		
1.4	Sales Tax WITH “C” FORM	01		
1.5	VALUE ADDED TAX (VAT) @ % RATE	01		
1.6	OTHER TAXES, IF ANY TO BE SPECIFIED (_____)	01		
1.7	TRANSPORTATION / FREIGHT CHARGES & TRANSIT INSURANCE CHARGES FROM MANUFACTURER / AUTHORIZED DEALER WORK PLACE TO BHEL OFFICE, AS PER BELOW: Asth. Engineer,Electrical Mtc. Sub-division,Gumma Power House,HPSEB, Chirgaon,Distt: Shimla-171208 (H.P.)	01		
1.8	TOTAL SUPPLY ORDER VALUE ON F.O.R DESTINATION BASIS	01		
1.9	- LESS VAT FOR SUPPLIES MADE FROM HIMACHAL PRADESH (HP) AGAINST VAT INVOICE , IF APPLICABLE (AS PER SL. NO 1.5)	01		
1.10	NET COST TO BHEL (SUM OF Sl. Nos.1.8+(-) 1.9)			
2	INSTALLATION & COMMISSIONING:	01		
2.1	Installation & commissioning FOR Hydraulic Dynamic Braking System with other components at destination. AS PER SPECIFICATION ENCLOSED IN ANNEXURE-1 of NIT. (THIS ALSO INCLUDES CHARGES OF VENDORS’ ENGINEER, BOARDING & LODGING CHARGES AND ALL OTHER CHARGES)	01		
2.2	SERVICE TAX	01		
2.3	TOTAL CHARGES FOR INSTALLATION & COMMISSIONING	01		
2.4	CENVAT CREDIT BENEFIT TO BHEL (AS PER CL 4 OF STC)	01		
2.5	NET COST (FOR INSTALLATION & COMMISSIONING) TO BHEL AFTER CONSIDERING CENVAT CREDIT (SL. NO. 2.3 – SL. NO. 2.4)	01		
2.6	TOTAL PRICE FOR SUPPLY & DEMONSTRATION OF Hydraulic Dynamic Braking System with other components (SL. NO. 1.8+ SL. NO. 2.3) – FOR ORDERING PURPOSE	01		
2.7	NET COST TO BHEL FOR SUPPLY & DEMONSTRATION OF Hydraulic Dynamic Braking System with other components (SL. NO. 1.10+ SL. NO. 2.5) – FOR TENDER EVALUATION PURPOSE	01		

NOTES:

1. Tenders will be evaluated based on “NET COST TO BHEL for SUPPLY & DEMONSTRATION OF Hydraulic Dynamic Braking System with other components” (Sl. No. 2.7).

2. Bidders are requested to quote for each and every item as indicated above. Please indicate NIL against items not applicable. Incomplete offer received may not be considered.
3. The Rate shall be entered in figures as well as in words. In case of difference in rates between words and figures THE LESSER OF THE TWO will be treated as valid rate.
4. In case of omission in quoting any rate, the evaluation will be done considering the highest quoted rate obtained against that item but the order, if placed, will be on the lowest quoted rate obtained against that item.
5. Bidders are requested to arrange the transporter and dispatch the goods on our behalf on freight (Including transit insurance) pre-paid basis. Goods to reach at destination within reasonable time say 10 days.
6. Any other Central Govt. /State Govt. taxes, Levies applicable, if not specified above, shall be reimbursed as per actual on submission of documentary proof from the concerned Govt. office.
7. **Two Separate Purchase Orders (POs) Shall Be Issued For Supply Of Hydraulic Dynamic Braking System with other components and Installation & Commissioning of Hydraulic Dynamic Braking System with other components.**
8. **For Central Sales Tax purposes, BHEL - PSNR, NOIDA shall provide C- Form to the respective bidder/supplier after despatches.**

(Signatures of the Bidder with Name, Designation & Company's Seal)

CERTIFICATE OF NO DEVIATION

(To be given in letter head)

TENDER No. : BHEL/PSNR/SCP/SS/E- 2661

I/ WE, M/s_____

HEREBY CERTIFY THAT NOT WITHSTANDING ANY CONTRARY INDICATIONS / CONDITIONS ELSEWHERE IN OUR OFFER DOCUMENTS, I/WE HAVE NEITHER SET ANY TERMS AND CONDITIONS NOR THERE IS ANY DEVIATION TAKEN FROM THE CONDITIONS OF BHEL'S TENDER SPECIFICATIONS, EITHER TECHNICAL OR COMMERCIAL, AND I/WE AGREE TO ALL THE TERMS AND CONDITIONS MENTIONED IN BHEL'S TENDER SPECIFICATION WITH ASSOCIATED AMENDMENTS & CLARIFICATIONS.

(Signatures of the Bidder with Name, Designation & Company's Seal)

REVERSE AUCTION (RA) FORMAT

BHEL reserves the right to go for Reverse Auction (RA) instead of opening the sealed envelope price bid, submitted by the bidder. This will be decided after techno-commercial evaluation. Bidders are also required to furnish following details in their techno-commercial bid, for this purpose.

Information and general terms and conditions governing RA are given below.

In case BHEL decides to process the tender through Reverse Auction Process (RA), following details shall be required from the bidders for their authorized representative who will participate in the on line Reverse Auction Process;

(a) Name of Designation of official:

(b) Postal Address (Complete):

(c) Telephone Nos. (Land line & Mobile both):

(d) FAX No.:

(e) E-mail address:

(f) Name of Place/State/Country, wherefrom he will participate in the RA:

(Signatures of the Bidder with Name, Designation & Company's Seal)

TERMS & CONDITIONS OF REVERSE AUCTION

Against this enquiry for the subject item/ system with detailed scope of supply as per enquiry specifications, BHEL may resort to "REVERSE AUCTION PROCEDURE" i.e., ON LINE BIDDING (THROUGH A SERVICE PROVIDER). The philosophy followed for reverse auction shall be English Reverse (No ties).

1. For the proposed reverse auction, technically and commercially acceptable bidders only shall be eligible to participate.
2. Those bidders who have given their acceptance for Reverse Auction (quoted against this tender enquiry) will have to necessarily submit „online sealed bid“ in the Reverse Auction. Non-submission of „online sealed bid“ by the bidder for any of the eligible items for which techno-commercially qualified, will be considered as tampering of the tender process and will invite action by BHEL as per extant guidelines in vogue.
3. BHEL will engage the services of a service provider who will provide all necessary training and assistance before commencement of on line bidding on internet.
4. In case of reverse auction, BHEL will inform the bidders the details of Service Provider to enable them to contact & get trained.
5. Business rules like event date, time, bid decrement, extension etc. also will be communicated through service provider for compliance.
6. Bidders have to fax the Compliance form before start of Reverse auction. Without this, the bidder will not be eligible to participate in the event.
7. In line with the NIT terms, BHEL will provide the calculation sheet (e.g., EXCEL sheet) which will help to arrive at "Total Cost to BHEL" like Packing & forwarding charges, Taxes and Duties, Freight charges, Insurance, Service Tax for Services and loading factors (for non-compliance to BHEL standard Commercial terms & conditions) for each of the bidder to enable them to fill-in the price and keep it ready for keying in during the Auction.
8. Reverse auction will be conducted on scheduled date & time.
9. At the end of Reverse Auction event, the lowest bidder value will be known on auction portal.
10. The lowest bidder has to fax/e-mail the duly signed and filled-in prescribed format for price breakup including that of line items, if required, as provided on case-to-case basis to Service provider within two working days of Auction without fail.
11. In case BHEL decides not to go for Reverse Auction procedure for this tender enquiry, the Price bids and price impacts, if any, already submitted and available with BHEL shall be opened as per BHEL"s standard practice.
12. Bidders shall be required to read the "Terms and Conditions" section of the auctions site of Service provider, using the Login IDs and passwords given to them by the service provider before reverse auction event. Bidders should acquaint themselves of the „Business Rules of Reverse Auction“, which will be communicated before the Reverse Auction.
13. If the Bidder or any of his representatives are found to be involved in Price manipulation/ cartel formation of any kind, directly or indirectly by communicating with other bidders, action *as per extant BHEL guidelines*, shall be initiated by BHEL and the results of the RA scrapped/ aborted.
14. The Bidder shall not divulge either his Bids or any other exclusive details of BHEL to any other party.
15. In case BHEL decides to go for reverse auction, the H1 bidder(s) (whose quote is highest in online sealed bid) may not be allowed to participate in further RA process.

Formats for execution of Performance Bank Guarantees:

Note: - The Bank Guarantee bonds (BG) are to be submitted on non-judicial stamp paper of Rs. 100/- and should be only from the Consortium Bank as per Annexure – 10.

PERFORMANCE BANK GUARANTEE

1. In accordance of M/s Bharat Heavy Electricals Limited (A Government of India undertaking, a Company incorporated under the Companies Act 1956 having its Registered Office at 'BHEL House', SIRI Fort, New Delhi 110 049) through its Division namely Power Sector Northern Region (PSNR) located at Noida, Uttar Pradesh-201301 (hereinafter called "the Company") having entered into a contract with hereinafter called "the said contractor" which term includes 'suppliers' for the purpose of this Bond and under the terms and conditions of the Contract No: dtd..... between BHEL-PSNR, Noida and as per the contract, the contractor/supplier is to furnish a Performance Bank Guarantee for Rs..... for the due performance of the equipment to be supplied under the above referred contract and for the fulfillment of all the terms and conditions of the contract.
2. We (indicate the name of the Bank) (herein after referred to as the Bank) at the request of (contractor(s)) do hereby undertake to pay the Company an amount not exceeding Rs..... against any loss or damage caused to or suffered or would be caused to or suffered by the Company by reason of any breach by the said contractor (s) of any of the terms and conditions contained in the said agreement.
3. We..... (indicate the name of the Bank with full address), do hereby undertake to pay the amounts due and payable under this guarantee without any demur, merely on a demand from the Company stating that the amount claimed is due by way of loss or damage caused to or would be caused to or suffered by the Company by reason of breach by the said Contractor(s) of any of the terms and conditions contained in the said Agreement or by the reason of the contractor(s) 'failure to perform' the said Agreement. Any such demand made on the Bank shall be conclusive as regards the amount due and payable by the Bank under this guarantee. However, our liability under this guarantee shall be restricted to an amount not exceeding Rs.....
4. We undertake to pay unconditionally to the Company any money so demanded notwithstanding any dispute(s) raised by the Contractor in any suit, or proceedings pending before any Court or Tribunal or Arbitration or before any other authority relating thereto our liability under this present being absolute and unequivocal. The payment under this guarantee would not wait till the disputes have been decided by any Court or Tribunal or in the arbitration proceedings or by any other authority. The payment so made by us under this Bond shall be a valid discharge of liability for payment there under and the Contractor (s) shall have no claim against us for making such payment.
5. We..... (indicate the name of Bank), further agree that the guarantee herein contained shall remain in full force and effect during the period that would be taken for the performance of the said Agreement and that it shall continue to be enforceable till all the dues of the Company under or by virtue of the said Agreement

have been fully paid and its claim satisfied or discharged or till Office/Department/Division of the Company certifies that the terms and conditions of the said Agreement have been fully and properly carried out by the said Contractor(s) and accordingly discharges this guarantee.

6. (i) Unless a demand or claim under this guarantee is made on us in writing on or before thewe shall be discharged from all the liability under this guarantee thereafter. But where such claim or demand has been preferred by the Company with the Bank before the expiry of the said date, the claim shall be enforceable notwithstanding the fact that the said enforcement is effected after the said date.

(ii) For the purpose of this clause, any letter making demand on the Bank by M/s BHEL will be dispatched by Registered Post with Ack. Due or by Telegram or by any Electronic media addressed to the above mentioned address of the Bank shall be deemed to be the claim/demand in writing referred to above irrespective of the fact as to whether and when the said letter reaches the Bank, as also any letter containing the said demand or claim is lodged with the Bank personally.

7. We(indicate the name of the Bank), further agree with the Company that the Company shall have the fullest liberty without our consent and without affecting in any manner our obligations hereunder to vary any of the terms and conditions of the said agreement or to extend time of performance by the said Contractor(s) from time to time or to postpone for any time of from time to time any of the powers exercisable by the Company against the said Contractor (s) and to forbear or enforce any of the terms and conditions relating to the said Agreement and we shall not be relieved from our liability by any reason of any such variation or extension being granted to the said contractor(s) or for any forbearance, act or omission on the part of the Company or any indulgence by the Company to the said Contractor(s) or by any such matter or thing whatsoever which under the law relating would, but for this provision, have effect of not so relieving us.
8. This guarantee will not be discharged due to the change in the constitution of the Bank or the Contractor(s).
9. It shall not be necessary for the Company to proceed against the contractor before proceeding against the guarantor-Bank and the guarantee herein contained shall be enforceable against them notwithstanding any security, which the Company may have obtained or obtain from the Contractor shall, at the time when proceedings are taken against the guarantor hereunder be outstanding or unrealized.
10. Any claim or dispute arising under the terms of this document shall only be enforced or settled in the Courts at Delhi.
11. The guarantor hereby declare that it has power to execute this guarantee and the executants has full powers to do so on its behalf under the proper authority granted to him /them by the guarantor.
12. We..... (Indicate the name of Bank) lastly undertake not to_revoke this guarantee during its currency except with the previous consent of the Company in writing. In witness where of we (indicate the name of Bank) have_here unto set out Bank Seal the Day month 20

LIST OF CONSORTIUM BANK

	Nationalised Bank		Public Sector Banks
1	Allahabad bank	20	IDBI
2	Andhra bank		Foreign bank
3	Bank of Baroda	21	CITI Bank N.A
4	Canara Bank	22	Deutsche Bank AG
5	Corporation bank	23	The Hongkong and Shanghai Banking Corporation Limited
6	Central bank	24	Standard Chartered Bank
7	Indian Bank	25	The Royal Bank of Scotland N.V.
8	Indian Oversea Bank	26	J P Morgan
9	Oriental bank of Commerce		Private bank
10	Punjab National Bank	27	Axis Bank
11	Punjab & Sindh Bank	28	The Federal Bank Limited
12	State Bank of India	29	HDFC
13	State Bank of Hyderabad	30	Kotak Mahindra Bank
14	Syndicate Bank	31	ICICI
15	State Bank of Travancore	32	Indusind Bank
16	UCO Bank	33	Yes Bank
17	Union Bank of India		
18	United Bank of India		
19	Vijaya Bank		

CERTIFICATE BY CHARTERED ACCOUNTANT ON LETTER HEAD

This is to certify that M/s. _____,
(hereinafter referred to as 'Company') having its registered office at _____
_____ is registered under MSMED Act 2006,
(Entrepreneur Memorandum No (Part II) _____
Dtd. _____, Category: _____ (Micro/Small). (Copy Enclosed)

Further verified from the Book of Accounts that the investment of the company as on date
_____ as per MSMED Act 2006 is as follows:

1. For Manufacturing Enterprises: Investment is plant and machinery (i.e., original cost excluding land and building and the items specified by the Ministry of Small Scale Industries vide its notification No. S.O. 1722(E) dated October 5, 2006:

Rs. _____ Lacs

2. For Service Enterprises: Investment in equipment (original cost excluding land and building and furniture, fittings and other items not directly related to the service rendered or as may be notified under the MSMED Act, 2006 :

Rs. _____ Lacs

The above investment of Rs. _____ Lacs is within the permissible limit of
Rs. _____ Lacs for _____ Micro/Small (strike off which is applicable)
Category under MSMED Act 2006.

Date:

(Signature)

Name –

Membership number –

Seal of Chartered Accountant -

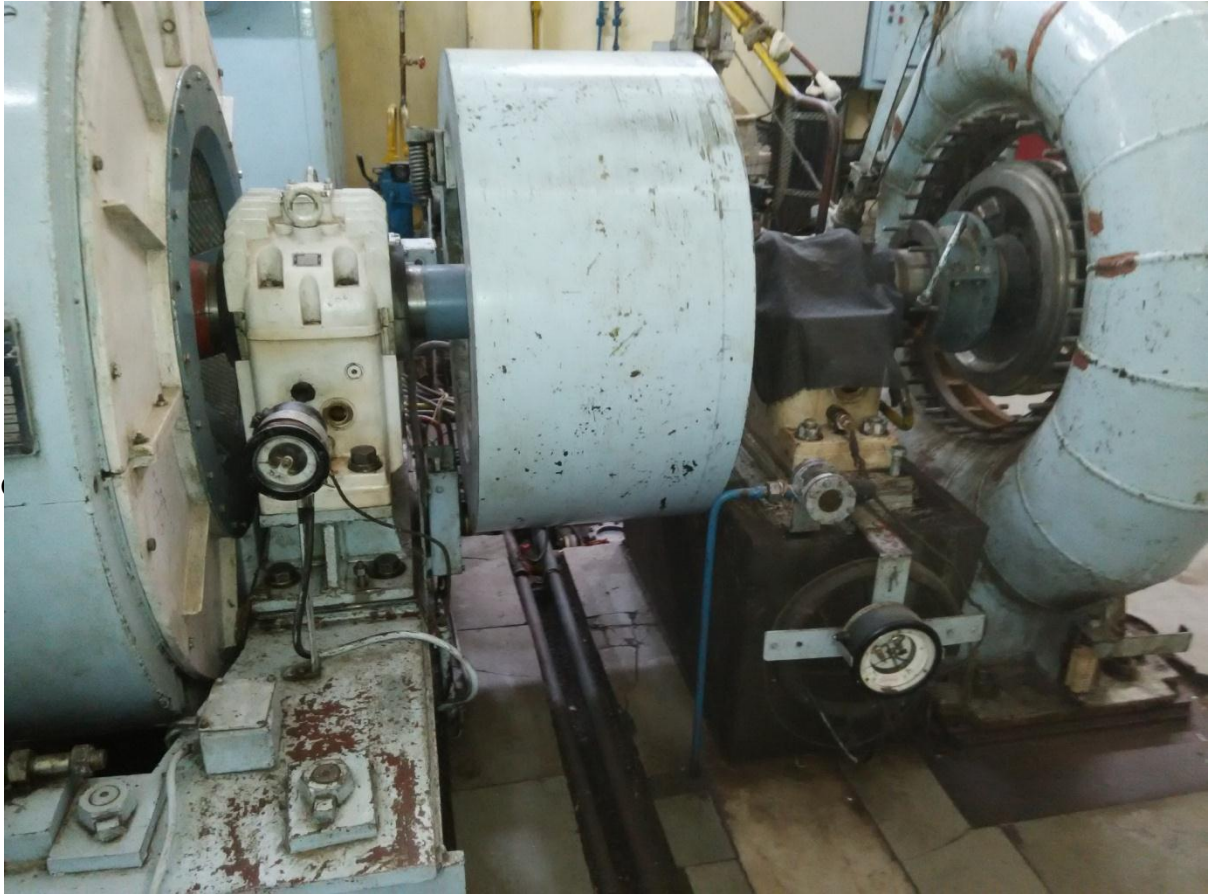
BRIEF IDEA FOR GENERALISED UNDERSTANDING OF JOB:

As you can see, this is a horizontal shaft hydro turbine. Hydraulic Dynamic Brakes are to be applied at shaft area called flywheel. As it is obvious, civil works are also to be carried out to support the structure of braking system; hence it has to be designed in such a way to withstand the braking pressure considering the available space.

Flywheel centreline is 1000 mm from ground level and flywheel dia is also 1000 mm, so space available below the flywheel from ground is around 500 mm. (This is just for your reference). Also, design should consider the sizes and numbers of brakes. Also, all calculations have to be done considering the Moment of Inertia of rotor, rpm of machine, braking speed, weight, dia etc., which is already provided in Technical Specification Sheet.

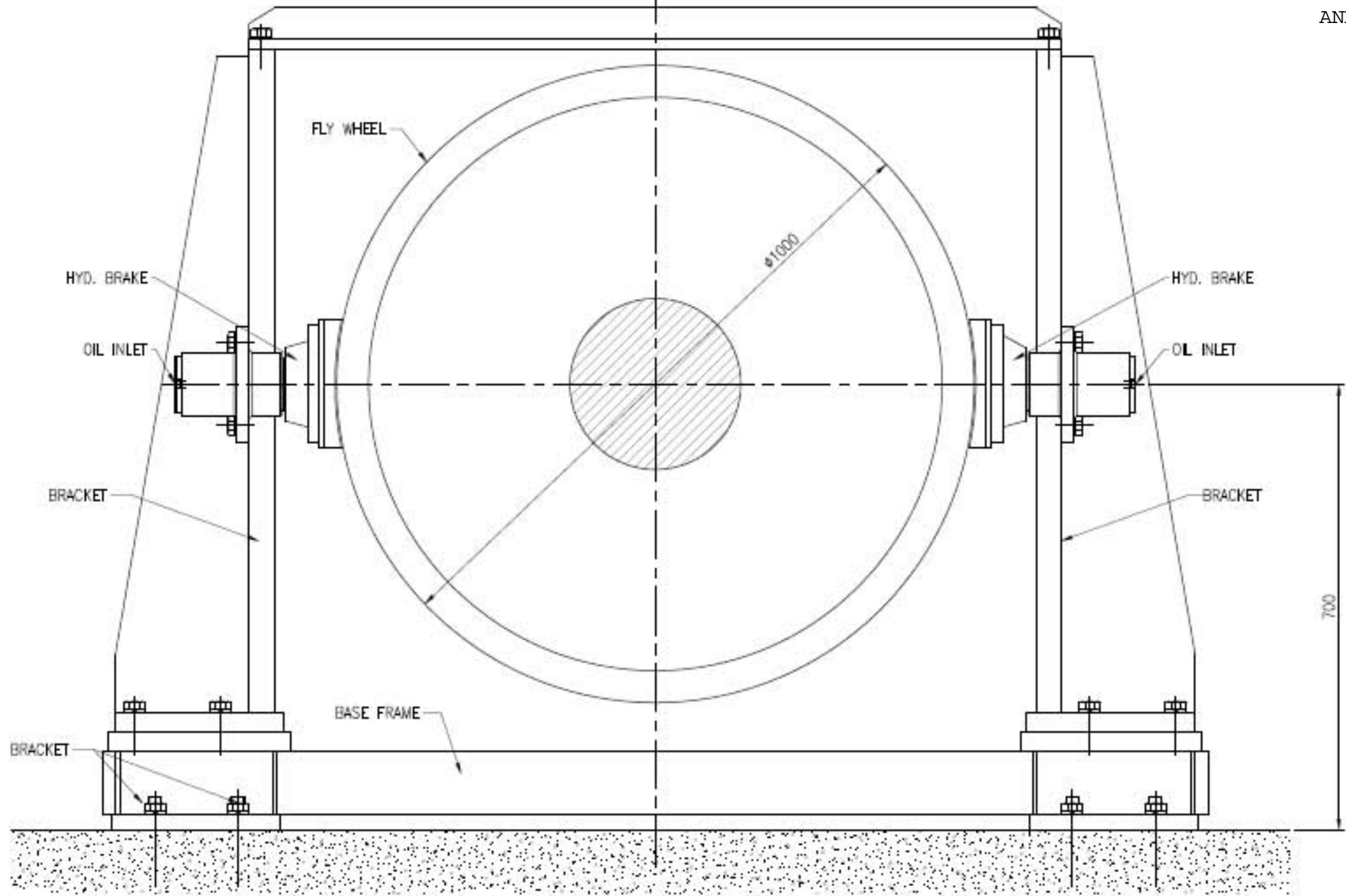

Rev.	Modification	Date	Sign

TOLERANCES UNLESS OTHERWISE STATED			
MACHINING		FABRICATION	
01-100 mm	± 0.15 mm	01-300 mm	± 1 mm
100-300 mm	± 0.4 mm	300-1000 mm	± 2 mm
300-1000 mm	± 0.8 mm	1000-2000 mm	± 3 mm

Project GUMMA HFP					
Client					
Material		Qty.	Wt.		
	Format A3	Scale	Title		
	M.V.M.	09.12.14	GENERAL ARRANGEMENT OF HYD. BRAKE		
Drawn			Drg. No.		Rev.
Checked			GMA/HB/01		0
Approved					Sheet 1/1

Break all sharp corners 0.2 mm max.

