

**BHARAT HEAVY ELECTRICALS LTD.  
CENTRAL FOUNDRY FORGE PLANT  
RANIPUR, HARDWAR  
MAINTENANCE & SERVICES DEPARTMENT  
MAINTENANCE-FORGE SHOP**

FF: 15: MFG: RM: ME: 12

Dt. 07/10/2015

**TENDER NOTICE – OPEN TENDER**

Two part Tenders in Sealed Envelopes are invited from technically and financially capable parties, having experience in work similar to- and interested in- the under mentioned works. The tender documents are available at website [www.bhel.com/www.bhelhwr.co.in](http://www.bhel.com/www.bhelhwr.co.in) in Tender Notification Section which can be downloaded. The tender should be submitted to the tender box placed in the office of the undersigned on or before **29/10/2015** at **2:30PM**, which will be opened on the same day in the office of under-signed at **3:00 PM** in presence of the bidders who wish to be present.

Bidders are advised to inspect the site before quoting their rates. Bidders are also advised to go through the Special Instructions attached to this notice. (ATTACHMENT-A)

BHEL reserves the right to reject any or all of the tenders without assigning any reason thereto.

<b>Tender No. &amp; Date</b>	<b>Description of Work</b>	<b>Earnest Money</b>	<b>Total Time of completion</b>	<b>Tender Cost</b>
FF: 15: MFG: RM: ME:12  Dated:07/10/2015	Final Machining, Grinding, Chrome Plating and buffing of Plungers for 2650T Press.	Rs.40,000/-  (Forty Thousand only)	6 Months	Nil



(Sandeep Kumar)  
Sr. Engr./M&S  
CFFP, BHEL  
Ranipur, Haridwar-  
249403  
(Uttarakhand)

Contact No. 01334-284165

E-mail ID: sandeep@bhelhwr.co.in

Copy To. :DGM (works) : for deputing finance representative for tender opening.

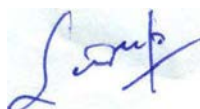

Signature of Issuing Officer

Signature of Bidder/Tenderer

ATTACHMENT-A**SPECIAL INSTRUCTIONS**

1. Kindly read this set of Special Instructions carefully before filling up the tender form.
2. **Pre-Qualification Requirements placed at Annexure C must be fulfilled by the vendor to participate in the tender and submitted along with Techno-Commercial Bid.**
3. The bidders are to submit the tender form along with all Annexures as well as this set of Special Instructions (Attachment-A); all pages duly signed.
4. The tender is to be submitted in two parts, viz.: i) Techno Commercial Bid and ii) Price Bid. Documents related with Pre-Qualification Requirements i.e. Annexure-C must be submitted along with Techno-Commercial Bid.
5. Both the Techno Commercial Bid and Price Bid are to be sealed separately in separate envelopes super-scribed with **“Techno Commercial Bid for Tender no. : “FF: 15: MFG: RM: ME: 12”** and **“Price Bid for Tender no. : “FF: 15: MFG: RM: ME: 12”** respectively and then placed in a common envelope super-scribed with **“Tender for Tender No.: “FF: 15: MFG: RM: ME: 12”**. The Techno Commercial Bid must also contain an un-priced copy of Price Bid.
6. Only the Techno Commercial bid will be opened on the day of tender opening. The Priced Bid will be opened only if Techno Commercial Bid(s) are found Technically Suitable & Acceptable. Date of opening of Price Bid will be intimated to all technically suitable and acceptable bidders at a suitable time.
7. Once Price Bids are opened and accepted by BHEL, the same cannot be withdrawn by the bidder for whatsoever reasons. In case a bidder withdraws his/her/their tender, suitable action may be taken by BHEL as deemed fit. This may include black listing of bidder or legal action.
8. If there is a difference found in the figures & words of the offered price. The price given in the words will be considered.

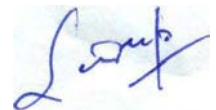
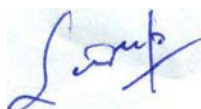
**(Issuing Officer)**

Signature of Issuing Officer

Signature of Bidder/Tenderer

**BHARAT HEAVY ELECTRICALS LTD.  
CENTRAL FOUNDRY FORGE PLANT  
RANIPUR, HARDWAR  
MAINTENANCE & SERVICES DEPARTMENT  
MAINTENANCE-FORGE SHOP**

**TENDER FORM for “Final Machining, Grinding, Chrome Plating and buffing of Plungers for 2650T Press.”**

**(PRICE BID)**

**PRICED/UNPRICED**

(PRICED PRICE BID TO BE SEALED IN SEPARATE ENVELOP)

Name & Address of Bidder	:	
Tender Notice No.	:	FF: 15: MFG: RM: ME: 12; Dated:07/10/2015
Last Date & Time for receipt of Tender	:	14:30 hrs on 29/10/2015
Date & Time for opening of Tenders	:	15:00 hrs on 29/10/2015
Place for opening of Tenders	:	Office of DGM (M&S)
Nature of Contract	:	Final Machining, Grinding, Chrome Plating and buffing of Plungers for 2650T Press.
Period of Contract	:	06 months

**SCOPE OF WORK:**

Final Machining, grinding, hard chrome plating and Buffing of Plungers for 2650T Press. Material of the Plungers (in rough size) will be supplied by CFFP, BHEL. All dimensions as per respective final drawing are to be achieved. Hard chrome plating of 50 microns to be done on all Plungers.

S. No.	Plungers	Final M/c Drawing No.	Qty.	Estimated Price Per Unit (Rs.)	Quoted Price Per Unit (A1) (Rs.)	Final Quoted Amount (A1*Qty.) (Rs.)
1	Plunger (Dia. 210x3810mm) 2650T Press , Long Travel Material: BP19388 Rough Drg. No. FPC-005/RMS	01-05-099	01	228800.00		
2.	Plunger (Dia. 150x3715mm) 2650T Press , Long Travel Material: HW10576 Rough Drg. No. FPC-006/RMS	01-05-098	02	194373.00		
3.	Plunger (Dia. 125x4260mm) 2650T Press , Cross Travel Material: HW10576 Rough Drg. No. FPC-007/RMS	01-05-093	01	208165.00		
4.	Plunger (Dia. 125x4050mm) 2650T Press , Cross Travel Material: HW10576 Rough Drg. No. FPC-008/RMS	01-05-094	01	202200.00		

Signature of Issuing Officer

Signature of Bidder/Tenderer

Total Quoted cost (A3)		
Deduction of value of Chips Generation (Rs.) (A4)		(- 5400)
<b>Total Final Quoted cost in Numbers (Rs.)(A3-A4)</b>		
<b>Total Final Quoted cost in Words (Rs.)</b>		

Enclosures:

1. Annexure-A: Special Terms and conditions
2. Annexure-B : Important Instructions
3. Annexure-C : Pre-Qualification Requirements
4. Annexure-D: Rough and final Drawings of Plungers



Signature of Issuing Officer

Signature of Bidder/Tenderer

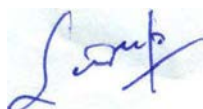

Signature of Issuing Officer

Signature of Bidder/Tenderer

**Special Terms & Conditions****Annexure-A**

1. Material of the plungers will be provided by BHEL.
2. Bidder has to give Bank Guarantee against full amount of the rough Plungers material cost as indicated in the tender document.
3. Valuation and deduction of cost of chips generated after machining @ Rs. 15/Kg from quoted rate.
4. CFFP/BHEL reserves the right to pre inspect the material at vendors works/ godown/ premises before final dispatch and during intermediary processes.
5. The cost of transportation to and fro will be borne by the vendor and is to be included in the bid.
6. The cost of transit insurance during transportation to and fro will be borne by the vendor and is to be included in the bid.
7. The Bidder has to lift the material in one, two or three lots and give bank guarantee of equivalent amount of material cost of lot value taken from CFFP, BHEL.
8. The work period will be 6 months for completion of work on 5 Plungers and dispatch date of material from CFFP, BHEL Haridwar Material Gate will reckoned.
9. The cumulative period for all the lots dispatched and received at CFFP, BHEL material Gate should not exceed 6 Months. If it so exceeds, LD will be imposed accordingly.
10. The vendor will be penalized for late delivery of the material from due date at the rate of 0.5% per week subject to maximum of 10%.
11. The final bid will be evaluated on total landed cost including transportation cost, insurance cost, works, taxes and other service charges inclusive.
12. Payment shall be made for each lot of plungers or in total after receipt and acceptance of material at CFFP works.
13. Contractor should submit process schedule at the time of tender.
14. Original Inspection report indicating surface roughness value, hardness value and all critical dimensions to be provided.
15. All drawings and standards are propriety of BHEL; it must not be used in any way detrimental to the interest of the company.
16. A guarantee for a period of 18 months from date of dispatch and 12 months from date of commissioning to be provided for chrome plating.
17. Lowest bidder will be decided on total cost basis. Part order shall not be awarded.

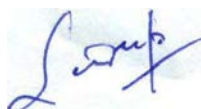

Signature of Issuing Officer

Signature of Bidder/Tenderer

**Annexure B****IMPORTANT INSTRUCTIONS**

Please read the instructions below carefully before filling the tender form. Tender form having any cuttings/overwriting will be cancelled. Do not remove any page from this form and sign both sides of the pages:

1. No tender documents will be accepted without submission of earnest money.
2. The contractor must sign each page of tender documents. In relation to the company or firm, the tender must be signed by the person who has the power of attorney, and a copy of the same must be enclosed with the tender form.
3. All the tenders must necessarily be accompanied with the Earnest Money as detailed in the Tender Notice/Tender Form. Any tender submitted without the Earnest Money will be liable to be rejected.
4. Once tenders are opened and accepted by BHEL, the same cannot be withdrawn by the bidder for whatsoever reasons. In case a bidder withdraws his/her/their tender, the earnest money deposited will be forfeited.
5. Service Tax will be reimbursed on providing Service Tax deposit receipt.
6. EMD is to be submitted in the form of Cash, Pay Order or demand draft
7. All documents of tender form and earnest money along with the receipt, received after depositing the DD/Pay order (CFFP) to the cash section, should be send to the DGM (M&S) by hand/by registered post/by courier in a sealed envelope before opening of tender.
8. Contract, that will be based on rules and regulations as per works policy, It will be applicable from the day BHEL issue the tender approval letter and other rules and regulations will also be acceptable that are instructed by BHEL.
9. BHEL will have the right to cancel any or all tenders and to accept any tender whether it is minimum or maximum. Incomplete forms will be cancelled.
10. Presence of tenderers at the time of tender opening is required.
11. After getting the contract, 5% of total contract amount must be deposited as security money (SD) before commencement of work which also includes the EMD amount and rest 5% amount will be deducted from the running account bills. 10% of the total contract amount including 5% SD will be released after completion of work contract. There will be no interest payable on this released amount by the BHEL.
12. During the execution of contract, if the contractor gets any other contract from other department, then he must inform the prior department in writing. If not informed, the contractor may prohibit from future partnership.
13. Lowest rate (L1) will be declared after adding the columns/categories of each part having the multiplication of Rate and Quantity.
14. The contractor(s) must have work experience.
15. No overdue interest clause to be added.
16. All the payments to contractor will be made through E-Payment.
17. This contract shall be a fixed price contract and BHEL shall not entertain any request from the contractor for enhancement of the contract price on grounds whatsoever.
18. Tenderers have to quotes the rates in the columns of tender forms in numbers and words only. All the rates have to be given in Rupees and no rate will be accepted in kilo, ton or bags terms. Overwritten and incomplete forms will be cancelled.
19. If the rate value given in numbers and words are different then the value given in words will be considered.

Signature of Issuing Officer

Signature of Bidder/Tenderer

20. Tenderer has to sign on the agreement before taking the Work order.
21. It is notified to all tenderers that they shall not be submitting any fake documents along with the tender form. All the collected documents can be examined at any point of time and if documents are found fake /forged, then appropriate action will be taken to the extent of cancellation of registration and tender.
22. In case the contractor defaults in commencing the work/lifting the rough machined plunger the within the time specified by BHEL in spite of a reasonable notice in writing or incase the contractor fails, to comply with any of the terms and conditions of the contract, in spite of 10 days notice in writing or incase he neglects or refuses to execute the contract or any part thereof at any stage, the contract shall, without prejudice to any other rights or remedies available to BHEL be liable to cancelled/termination in part or as a whole. In the event of cancellation/termination. The contractor shall be liable to compensate BHEL for all loss incurred by BHEL including the loss suffered on account of having the work executed through any other contractor or department as may be convenient to BHEL in accordance with the exigencies of the work.
23. In the event of cancellation/termination, the contractor shall be liable to compensate BHEL for all losses incurred by BHEL including the loss suffered on account of having the work executed through any other contractor or department as may be convenient to BHEL in accordance with the exigencies of the work. In case only a part of the contract is cancelled, the remaining portion of contract may be allowed to be executed by the contractor. All disputes arising in connection with the contract shall be settled by mutual consultation if no agreement is reached the dispute shall be settled in accordance with the provisions of the Arbitration and conciliation Act, 1996 and the rules made there under. The dispute shall be referred for arbitration to any arbitrator to be appointed by the Head of the BHEL CFFP Unit. The award of the arbitrator shall be final and binding on both the Parties. The venue of the Arbitration shall be Haridwar (U.K.) in India. The questions, disputes, differences arising under, out of or in connection with this contract shall be to the exclusive jurisdiction of Haridwar Courts.

I accept all the instruction above. (Bidder)

(Issuing Officer)

(Bidder/Tenderer)

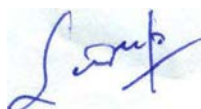

Signature of Issuing Officer

Signature of Bidder/Tenderer

**PQR (Pre- Qualification Requirement)****Annexure- C**

1. Bidder must have in-house facilities for Machining, Grinding, Hard Chrome Plating and Buffing of Plungers/Piston of Size more than  $\varnothing$ 100mm & Length 2500mm.

**Note: Necessary Document mentioning size of Manufacturing Equipments (Lathes, Milling Machine, Chrome Plating Tank) installed in the premises of Plant shall be submitted by the vendor.**

2. Bidder should have successfully completed similar job work/ Purchase order of Machining, Grinding, Hard Chrome Plating and buffing of Plungers/Pistons of size more than Dia.  $\varnothing$ 100mm & Length 2500mm.

**Note: Bidder should submit the copies of purchase orders/ Completion certificate of work duly signed by customers with details of address, contract person, and telephone No. & e-mail address.**

4. Average annual financial turnover during the last 3 years ending 31st March of the previous financial year, should be at least 3.08 Lakhs.

**Note. ITR , Profit & Loss , and Balance sheet to be submitted**

5. Experience of having successfully completed similar works during last 7 years ending last day of month previous to the one in which applications are invited should be either of the following:-

a) Three similar completed works each costing equal to or more than Rs. 4.1 Lakhs

Or

b) Two similar completed works each costing equal to or more than Rs. 5.1 Lakhs.

Or

c) One similar completed work each costing equal to or more than Rs. 8.2 Lakhs.

**Similar work Means** `` have successfully completed purchase orders / work orders for Machining, Grinding, Hard Chrome Plating and Buffing of Plungers/ Pistons of size more than Dia.  $\varnothing$ 100mm & Length 2500mm.

**Note: Bidder should submit the copies of purchase orders/ Completion certificate of work duly signed by customers with details of address, contract person, and telephone No. & e-mail address.**

**Note: BHEL reserves the right to verify information submitted by bidder. In case the information is found to be false/ incorrect, the offer shall be rejected.**

Signature of Issuing Officer

Signature of Bidder/Tenderer

# ROUGH MACHINED SKETCH

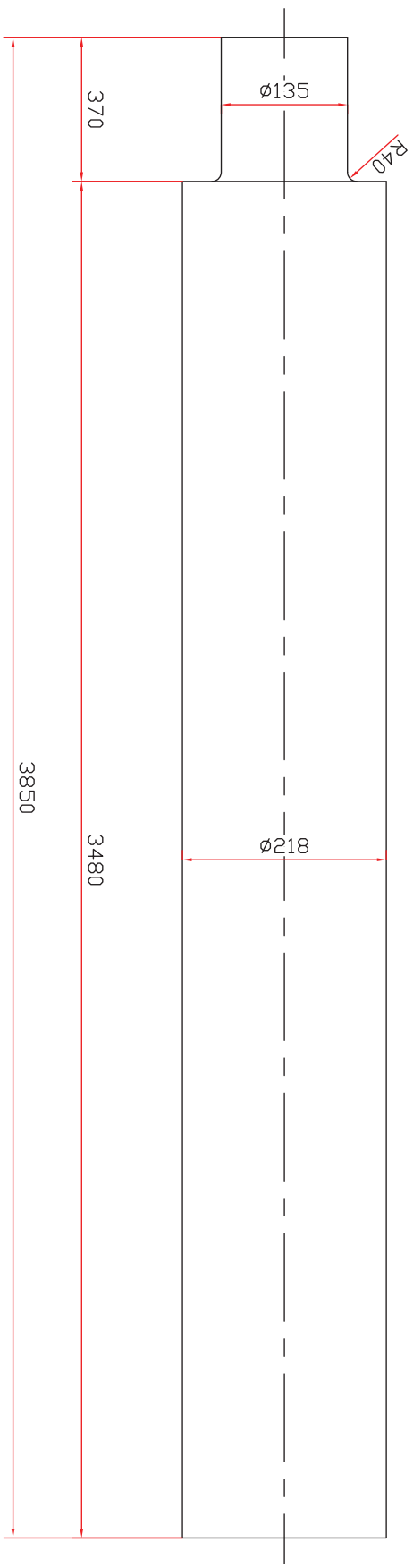

- NOTE:**
1. TOLERANCE ON DIA +2, -0  
ON TOTAL LENGTH +5, -0
  2. CHAMFER ALL SHARP EDGES TO 2x45°

 BHARAT HEAVY ELECTRICALS LIMITED RANIPUR, HARDWAR		DRN.	P KALHAN	NAME		MATERIAL	CK45/DIN:1.1181
		CHD	SANDEEP	SIGN.		DATE	
		APPD	N K CHAUHAN	REV.			
DEPTT. FORGE SHOP CODE 920		SCALE	WEIGHT (KG) Kg	<b>REF DWG NO. : 01.05.099</b>		DRAWING NO.	
TITLE <b>PLUNGER (Ø210 X 3810)</b> (2650T-LONG TRAVEL)				SHEETS No. 01		No. of Sheets 01	
				FPC-005/RMS		00	

FIRST ANGLE PROJECTION (ALL DIMENSIONS ARE IN M.M.)

The information on this document is the property of BHARAT HEAVY ELECTRICALS LIMITED. It must not be used directly or indirectly in any way detrimental to the interest of the company.

DEWAG MEER  
Ref. Drg. No.  
5030004-15-163

Sign & Date

Inventory No.

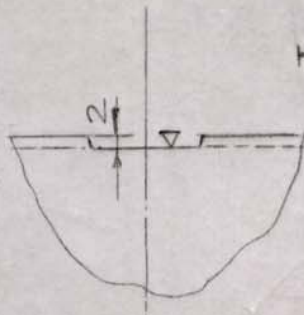
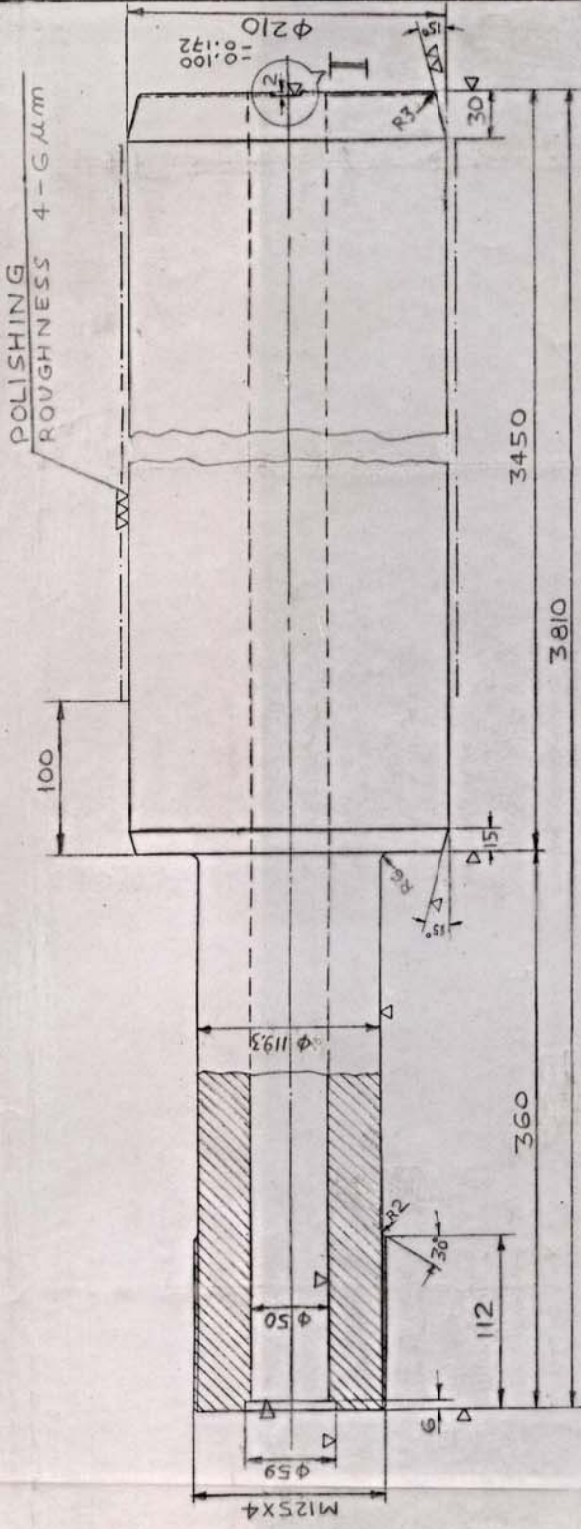
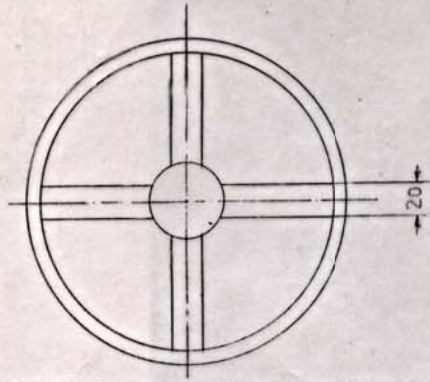

SURFACE HARDENED

DETAIL-I

INSTALLED QTY-1 No.

**BHARAT HEAVY ELECTRICALS LIMITED.**  
**UNIT: CENTRAL FOUNDRY FORGE PLANT.**  
**HARDWAR**



C 0.42-0.50, Si 0.15-0.35  
Mn 0.5-0.8, P (max) 0.035  
S (max) 0.035  
MATERIAL-CK 45/DIN: 1.1181

ALL SHARP CORNERS TO BE ROUNDED OFF.

REV.	DATE	ALTERED	CHECKED

REV.	DATE	ALTERED	CHECKED

DEPTT.	DESIGN BUREAU	SCALE	NTS	WEIGHT(KGS.)	ITEM NO.
				910 KG	

TITLE	REF. to ASSY. DRG.
PLUNGER Ø210 FOR LONG TRAVEL 2650 T FORGE PRESS	

DRAWN	CHECKED	APPROVED	NAME	SIGN.	DATE
			KISHORI LAL		12.8.04
			PB G		1.4.04

DRAWING NO.	REV.
01,05,099	0

SHEET NO.	NO. OF SHEETS
1	1

# ROUGH MACHINED SKETCH

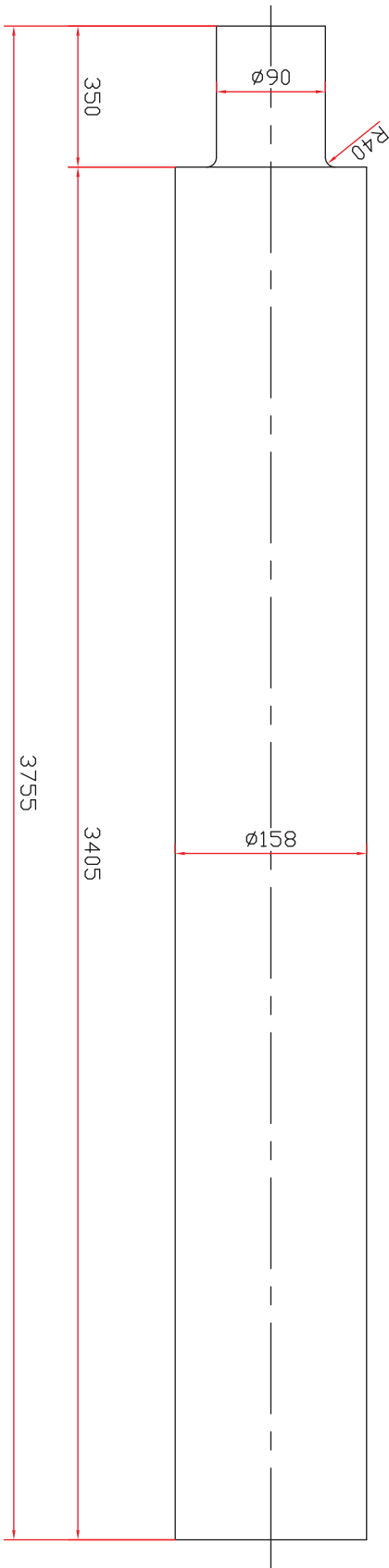

- NOTE:**
1. TOLERANCE ON DIA +2, -0  
ON TOTAL LENGTH +5, -0
  2. CHAMFER ALL SHARP EDGES TO 2x45°

COPYRIGHT AND CONFIDENTIAL

THE INFORMATION ON THIS DOCUMENT IS THE PROPERTY OF BHARAT HEAVY ELECTRICALS LIMITED. IT MUST NOT BE USED DIRECTLY OR INDIRECTLY IN ANY WAY DETERIMENTAL TO THE INTEREST OF THE COMPANY.



BHARAT HEAVY ELECTRICALS LIMITED  
RANIPUR, HARDWAR

NAME	MATERIAL	DATE
DRN. P KALHAN	CK45/DIN.1181	
CHD SANDEEP		
APPD N K CHAUHAN		

**REF DWG NO. : 01.05.098**

DEPTT.	FORGE SHOP	SCALE	WEIGHT (KG)	DRAWING NO.	REV.
CODE	920		Kg		

TITLE	REF DWG NO.	REV.
<b>PLUNGER (Ø150 x 3715)</b> (2650T-LONG TRAVEL)	<b>FPC-006/RMS</b>	<b>00</b>

Sheet No.	No. of Sheets
01	01

FIRST ANGLE PROJECTION (ALL DIMENSIONS ARE IN M.M.)

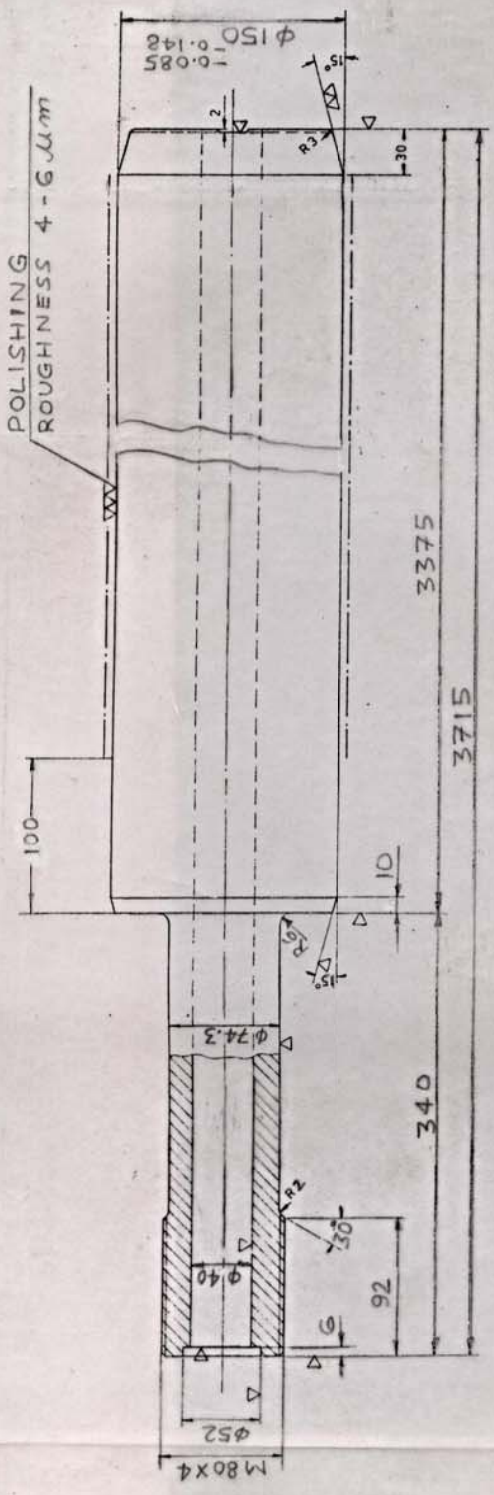

The information on this document is the property of BHARAT HEAVY ELECTRICALS LIMITED. It must not be used directly or indirectly in any way detrimental to the interest of the company.

Ref. Drg. No. DEMAG MEER DRG 5030004-15.162

INSTALLED QTY. - 2 NOS.

C 0.42-0.50, Si 0.15-0.35  
Mn 0.5-0.8, P(MAX.) 0.045  
S(MAX.) 0.045  
MATERIAL-C45/DIN: 1.1181

**BHARAT HEAVY ELECTRICALS LIMITED.**  
UNIT: CENTRAL FOUNDRY FORGE PLANT.  
HARDWAR

ALL SHARP CORNERS TO BE ROUNDED OFF.

REV.	DATE	ALTERED CHECKED

REV.	DATE	ALTERED CHECKED

REV.	DATE	ALTERED CHECKED

DEPTT. DESIGN BUREAU	SCALE	WEIGHT(KGS.)	REF. TO ASSY DRG.	ITEM NO.
	N.TS	445.0		

PLUNGER  $\phi 150$   
FOR LONG TRAVEL  
FOR 2650T PRESS

DRAWN	CHECKED	APPROVED	NAME	SIGN.	DATE
KISHORI LAL	P B G	P B G	KISHORI LAL	[Signature]	2.8.04
					9.9.04

DRAWING NO. 01,05,098  
SHEET NO. 1 NO. OF SHEETS 1

Dimensions to be controlled Within Limits as Shown  
Machining Tolerance: 0.25 mm Unless Otherwise Shown. Max Machining Tolerance  $\pm$

# ROUGH MACHINED SKETCH

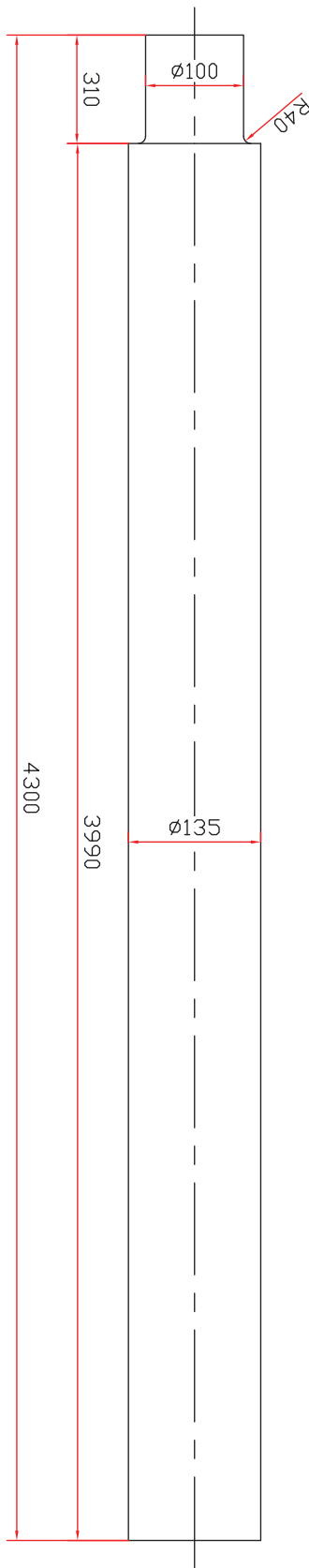

- NOTE:**
- TOLERANCE ON DIA +2, -0  
ON TOTAL LENGTH +5, -0
  - CHAMFER ALL SHARP EDGES TO 2x45°

COPYRIGHT AND CONFIDENTIAL

THE INFORMATION ON THIS DOCUMENT IS THE PROPERTY OF BHARAT HEAVY ELECTRICALS LIMITED. IT MUST NOT BE USED DIRECTLY OR INDIRECTLY IN ANY WAY DETERIMENTAL TO THE INTEREST OF THE COMPANY.



BHARAT HEAVY ELECTRICALS LIMITED  
RANIPUR, HARDWAR

NAME	MATERIAL	DATE
DRN. P KALHAN	CK45/DIN:1.1181	
CHD SANDEEP		
APPD N K CHAUHAN		

**REF DWG NO. : 01.05.093**

DEPTT. FORGE SHOP	SCALE	WEIGHT (KG)	DRAWING NO.	REV.
CODE 920		Kg		

TITLE	FPC-007/RMS	00
PLUNGER ( $\varnothing 125 \times 4260$ )		
(2650T-CROSS TRAVEL)		
Sheets No.	01	No. of Sheets
		01

FIRST ANGLE PROJECTION (ALL DIMENSIONS ARE IN M.M.)

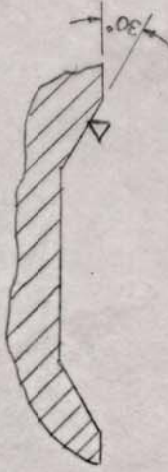
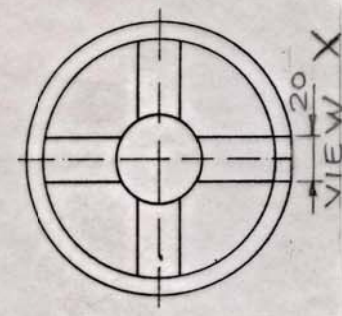
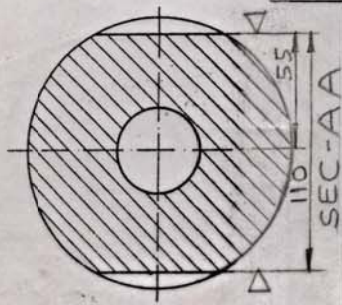
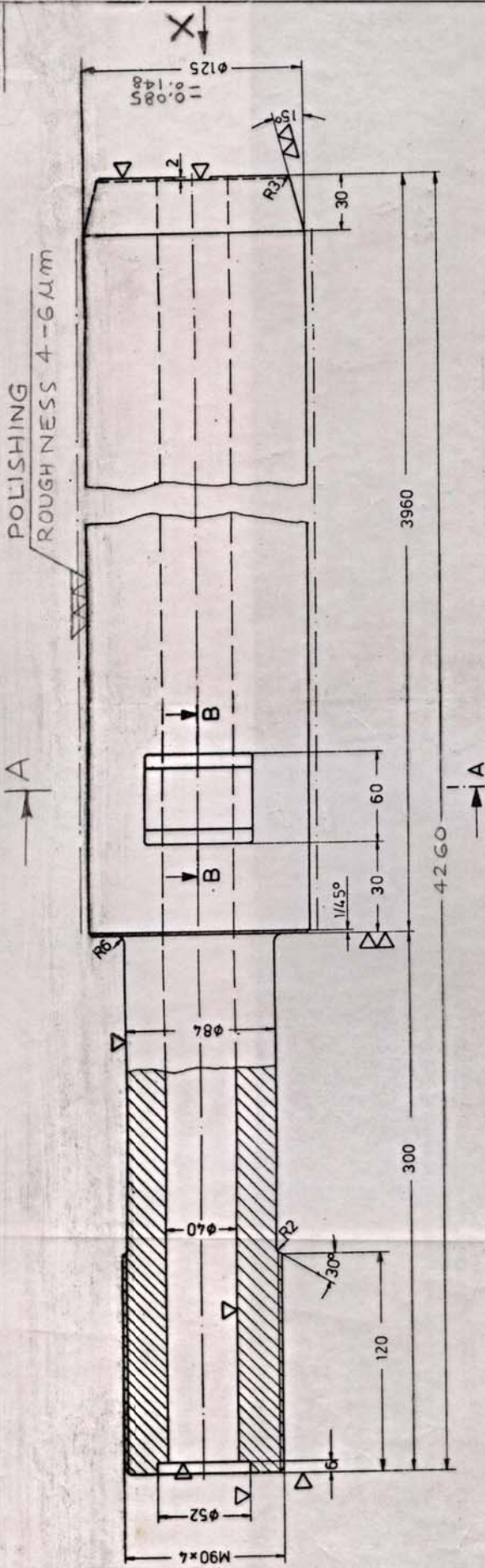

SEC-BB INSTALLED QTY-1NO.

A C 0.42-0.50, Si 0.15-0.35, Mn 0.5-0.8, P(MAX) 0.035, S(MAX) 0.035

**BHARAT HEAVY ELECTRICALS LIMITED.**  
**UNIT: CENTRAL FOUNDRY FORGE PLANT.**  
**HARDWAR**



DEPTT. DESIGN BUREAU		SCALE 1:2.5	WEIGHT(KGS.) 352.0	REF. to ASSY. DRG.	ITEM NO.
TITLE		PLUNGER Ø125 FOR CROSS TRAVEL 2650T FORGE PRESS		DRAWN KISHORI LAL	SIGN. DATE 10.8.00
MATERIAL-CK45/DIN:1.1181		ALL SHARP CORNERS TO BE ROUNDED OFF.		CHECKED P.B.G.	APPROVED P.B.G.
REV.	DATE	ALTERED CHECKED	REV.	DATE	ALTERED CHECKED
SIGN & DATE		DE MAG MEER		Inventory No.	
Ref. Drg. No. 5030004-15.685		The information on this document is the property of BHARAT HEAVY ELECTRICALS LIMITED. It must not be used directly or indirectly in any way detrimental to the interest of the company.		DRAWING NO. 01, 05, 093	
				SHEET NO. 1 NO. OF SHEETS	

DRAWING NO. 01, 05, 093  
 SHEET NO. 1 NO. OF SHEETS

# ROUGH MACHINED SKETCH

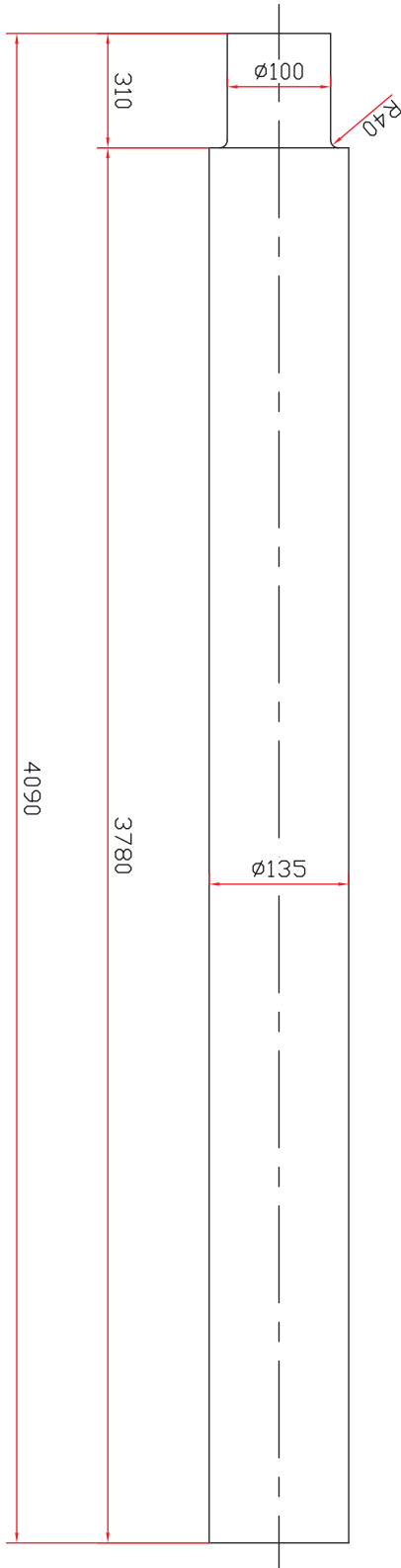

- NOTE:**
1. TOLERANCE ON DIA +2, -0  
ON TOTAL LENGTH +5, -0
  2. CHAMFER ALL SHARP EDGES TO 2x45°

COPYRIGHT AND CONFIDENTIAL

THE INFORMATION ON THIS DOCUMENT IS THE PROPERTY OF BHARAT HEAVY ELECTRICALS LIMITED. IT MUST NOT BE USED DIRECTLY OR INDIRECTLY IN ANY WAY DETERIMENTAL TO THE INTEREST OF THE COMPANY.



**BHARAT HEAVY ELECTRICALS LIMITED**  
RANIPUR, HARDWAR

DEPTT.	FORGE SHOP	SCALE	WEIGHT (KG)	NAME	MATERIAL	GS17GM055
CODE	920		Kg	DRN.	P KALHAN	
				CHD	SANDEEP	
				APPD	N K CHAUHAN	

**REF DWG NO. : 01.05.094**

DRAWING NO.

REV.

TITLE  
**PLUNGER (Ø125 X 4050)**  
(2650T-CROSS TRAVEL)

Sheets No.	01	No. of Sheets	01
<b>FPC-008/RMS</b>		<b>00</b>	

FIRST ANGLE PROJECTION (ALL DIMENSIONS ARE IN M.M.)

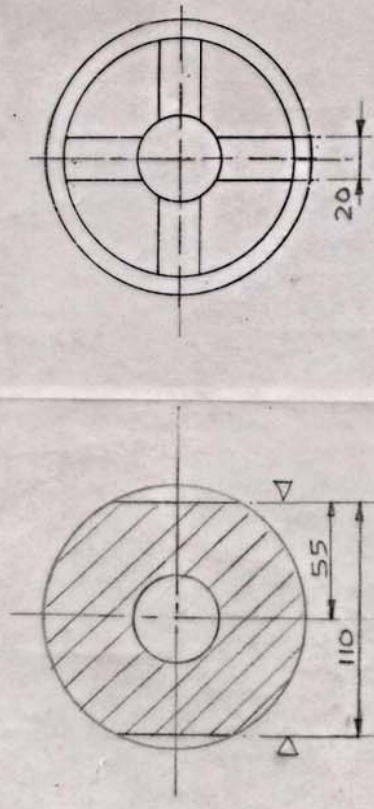
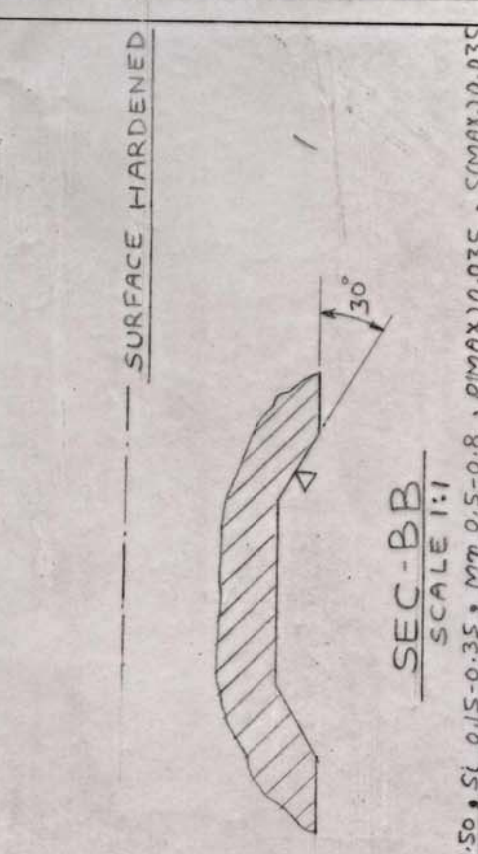
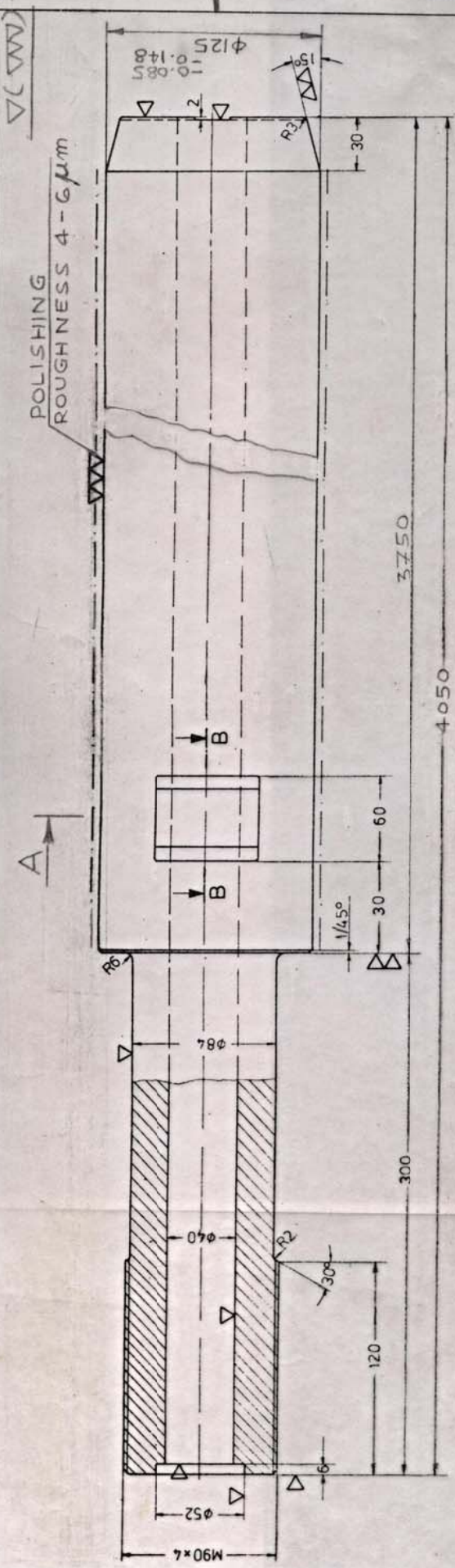

**BHARAT HEAVY ELECTRICALS LIMITED.**  
**UNIT: CENTRAL FOUNDRY FORGE PLANT.**  
**HARDWAR**

C 0.42-0.50, Si 0.15-0.35, Mn 0.5-0.8, P(MAX) 0.035, S(MAX) 0.035

DEPT. DESIGN BUREAU

SCALE 1:25

WEIGHT (KGS.) 334.0

REF. TO ASSY. DRG.

ITEM NO.

TITLE

PLUNGER Ø125 FOR CROSS TRAVEL 2650T FORGE PRESS

Dimensions to be controlled Within Limits as Shown Machining Tolerance: 0.25 mm Unless Otherwise Shown. Non Machining Tolerance ±

REV.	DATE	ALTERED	CHECKED	REV.	DATE	ALTERED	CHECKED
MATERIAL: CK45/DIN: 1.1181				MATERIAL: CK45/DIN: 1.1181			
INSTALLED QTY - 1 NO.				INSTALLED QTY - 1 NO.			
SIGN & DATE				SIGN & DATE			
DEMAJ MEER				DEMAJ MEER			
Ref. Drg. No. 5030004-15.686				Ref. Drg. No. 5030004-15.686			
Inventory No.				Inventory No.			
SHEET NO. 1				SHEET NO. 1			
NO. OF SHEETS 1				NO. OF SHEETS 1			
DRAWING NO. 01, 05, 094				DRAWING NO. 01, 05, 094			
REV. 0				REV. 0			