



BHARAT HEAVY ELECTRICALS LIMITED

POWER PLANT PIPING UNIT

THIRUMAYAM- 622 507

CONTRACTS DEPARTMENT

Phone : 04333279551

E.mail : ilango@bheltry.co.in Website : www.bhel.com

Tender No:PPPU:WC:14:015

Tender Notice

Dt. 04.10.2014

To,

Dear Sirs,

Sub: Open Tender inviting Technical & Price Bid for the "Construction of foundations for 40T Furnace, Chimney, Blower and Blower shed & Control room at BHEL-PPPU, Thirumayam" – reg.

Please submit your competitive bid for the following scope of work as per the conditions given in the WORK/RATE SCHEDULE enclosed along with the tender.

Scope of work:	Construction of foundations for 40T Furnace, Chimney, Blower and Blower shed & Control room at BHEL-PPPU, Thirumayam.
Duration of Contract:	5 Months
Last Date / Time for receipt of tender:	14.00 hrs on 31.10.2014
Date / Time for opening of Technical Bid:	14.30 hrs on 31.10.2014
Date/Time of Reverse Auction / Price Bid Opening:	The Bidders who are technically qualified will be called for Reverse Auction / Price Bid Opening. The Date / Time of reverse auction / Price Bid Opening will be intimated to the Qualified Bidders separately.
EMD	₹ 1,00,000/- to be submitted in the form of DD only in favour of "BHEL – Thirumayam".

SPECIAL INSTRUCTIONS:

This Tender is subject to General terms & conditions, which is enclosed.

- The Technical Bid along with all Terms & Conditions shall be duly signed and stamped in all pages and placed in a cover duly superscripting as "TECHNICAL BID". Bids submitted with incomplete and incorrect technical details will be liable for rejection.
- Tenderer should furnish the INDIVIDUAL ITEM RATE in the enclosed "PRICE BID". Bill of Quantities and shall be duly signed and sealed and placed in a separate cover duly superscripting as "PRICE BID".
- EMD should be submitted in a separate cover duly superscripting as "EMD".
- Totally there will be 3 Separate covers. One cover for Technical Bid, one cover for Price Bid and another cover for EMD. All the above 3 covers shall be placed in a common sealed cover and shall be submitted before the said due date as given above superscripting the tender no. & date and Due Date.

Place
Date

Signature of the Bidder
(NAME & ADDRESS WITH SEAL)



BHARAT HEAVY ELECTRICALS LIMITED

POWER PLANT PIPING UNIT

THIRUMAYAM- 622 507

CONTRACTS DEPARTMENT

Phone : 04333279551

E.mail : ilango@bheltry.co.in Website : www.bhel.com

Tender No:PPPU:WC:14:015

Tender Notice

Dt. 04.10.2014

- Tenderers should submit their bids before the said due date as given above in a sealed cover superscripting the Tender number, Tender date & Due Date and the tender will be opened in the presence of tenderers with due authorization.

- This tender is subject to the following:

GENERAL DETAILS ABOUT VENDOR	3
PRE-QUALIFICATION CRITERIA (PQC)	4
WORK SPECIFIC TERMS AND CONDITIONS	10
COMMERICAL TERMS AND CONDITIONS	30
CONDITIONS RELATED TO THE WELFARE OF LABOUR	34
GENERAL TERMS & CONDITIONS OF CONTRACT	38
TERMS & CONDITIONS RELATED TO SAFETY	48
GENERAL AND SPECIAL SPECIFICATIONS	92
PRICE BID	238

Any deviation to this tender terms & condition and schedules of this tender will lead to total rejection of the bid submitted.

- At the time of opening of Tender, the representatives should produce the authorization obtained from the authorized signatory of the tenderer specifying the purpose. Also the specimen signature of the representative should be authorized.
- BELATED and incomplete bids will become liable for rejection.

In case you are not in a position to submit the bid, please send mail / letter suitably specifying the reasons thereof.

Thanking you,
For Bharat Heavy Electricals Ltd.

Sr.Manager / Contracts
Bay-5, East End Block
Power Plant Piping Unit,
BHEL, Thirumayam - 622 507.

Note:- The Tender shall be sent to the above address. It may be noted that the Contracts department is at a walking distance of 10 minutes from PPPU Main Entry gate. The time of submission of bids needs to be planned accordingly.

Place
Date

Signature of the Bidder
(NAME & ADDRESS WITH SEAL)



BHARAT HEAVY ELECTRICALS LIMITED

POWER PLANT PIPING UNIT

THIRUMAYAM- 622 507

CONTRACTS DEPARTMENT

Phone : 04333279551

E.mail : ilango@bheltry.co.in Website : www.bhel.com

Tender No:PPPU:WC:14:015

Tender Notice

Dt. 04.10.2014

GENERAL DETAILS ABOUT VENDOR

NAME OF SERVICE PROVIDER		
Sl. No.	Details required	Data to be furnished.
1	Head Office Name & Address with Phone No., Email & Fax No.	
2	Local Office Address with Contact person, Phone No., Mobile No., email ID, Fax No. (If any)	
3	Name of contact Person	

Declaration:

- (i) I/We (including all partners) certify that I/We have read the Terms and conditions and shall abide by them.
- (ii) I/We certify that the information given above is true to the best of our knowledge. I/We also understand that if any of the information is found wrong, I/We am/are liable to be debarred.
- (iii) I/We certify that I/We will not get myself / ourselves registered as contractor(s) in BHEL under more than one name.

Place
Date

Signature of the Bidder
(NAME & ADDRESS WITH SEAL)



BHARAT HEAVY ELECTRICALS LIMITED

POWER PLANT PIPING UNIT

THIRUMAYAM- 622 507

CONTRACTS DEPARTMENT

Phone : 04333279551

E.mail : ilango@bheltry.co.in Website : www.bhel.com

Tender No:PPPU:WC:14:015

Tender Notice

Dt. 04.10.2014

PRE-QUALIFICATION CRITERIA (PQC)

S.NO	ELIGIBILITY CRITERIA	BIDDER'S RESPONSE		
*01	EMD	DD No. _____ Date _____ Drawn from _____ (Bank) for Rs. _____ / (Rupees _____ only) Or One time EMD of ₹2 lakhs remitted at Thirumayam only. CR ref: _____ (in the form of DD only).		
*02	Income Tax PAN No. Private Ownership - PAN card on owner Name Limited Company - PAN card on company Name Partnership Firm - PAN card on Firm Name	_____ COPY OF PAN CARD SHOULD BE ATTACHED		
*03	Service Tax Regn. No. (Proof to be Attached)	Regn. No : Proof attached / proof not attached		
04	Company Status (Private / Public / Proprietor / Registered) (Proof to be attached)	Company status : Proof attached / proof not attached		
*05	Income Tax assessment order or acknowledgement of Income Tax Return for 3 financial years (Proof to be Attached).	2011 – 12	2012 - 13	2013 - 14
		Attached	Attached	Attached
		Not Attached	Not Attached	Not Attached
*06	Audited Financial Statements including Balance Sheet, P&L statement for 2013- 14, 2012-13, 2011-12 to be submitted.	Attached		Not Attached
*07	Average annual financial turnover should not be less than ₹14 lakhs in last three years.	Attached		Not Attached
*08	During the last 7 years, the bidder should have completed 1. Three Civil Construction / Maintenance works each not less than Rs. 18 Lakhs or 2. Two Civil Construction / Maintenance works each not less than Rs. 23 Lakhs or 3. One Civil Construction / Maintenance work not less than Rs. 37 Lakhs	Attached		Not Attached

Place
Date

Signature of the Bidder
(NAME & ADDRESS WITH SEAL)



BHARAT HEAVY ELECTRICALS LIMITED

POWER PLANT PIPING UNIT

THIRUMAYAM- 622 507

CONTRACTS DEPARTMENT

Phone : 04333279551

E.mail : ilango@bheltry.co.in Website : www.bhel.com

Tender No:PPPU:WC:14:015

Tender Notice

Dt. 04.10.2014

S.NO	ELIGIBILITY CRITERIA	BIDDER'S RESPONSE	
	Bidder to provide Performance Certificate / Work Order for having executed & completed the above mentioned works.		
09	Experienced Staff availability of minimum Graduate Engineer – 1 No and Diploma Supervisor – 1 No to be ensured during execution.	Accepted	Not Accepted
10	Production of PF and ESI / Group Insurance Registrations and complying to the rules on these as per the ESI & PF Acts.	Accepted	Not Accepted
11	Acceptance to participate in Reverse Auction	Accepted	Not Accepted

*Point Nos: 1, 2, 3, 5, 6, 7 and 8 are mandatory and all relevant details and photocopies of certificates are to be furnished in the Technical Bid without which bids will not be considered for further evaluation.

Place
Date

Signature of the Bidder
(NAME & ADDRESS WITH SEAL)



BHARAT HEAVY ELECTRICALS LIMITED

POWER PLANT PIPING UNIT

THIRUMAYAM- 622 507

CONTRACTS DEPARTMENT

Phone : 04333279551

E.mail : ilango@bheltry.co.in Website : www.bhel.com

Tender No:PPPU:WC:14:015

Tender Notice

Dt. 04.10.2014

ANNEXURE – I of PQC

DETAILS OF PLANTS AND EQUIPMENTS OWNED / AVAILABLE WITH VENDOR

Sl. No.	Name of Equipments	Nos.	Capacity or Type	Age	Remarks
	Earth moving equipments				
1.	Excavator (Various sizes)				
	Equipments for hoisting & lifting				
1	Mobile crane				
2.	Tower crane				
3.	Builder's hoist				
	Equipments for concrete works				
1.	Concrete batching plant				
2.	Concrete pump				
3.	Concrete transit mixer				
4.	Concrete mixer (diesel)				
5.	Concrete mixer (electrical)				
6.	Concrete vibrator (electrical)				
7.	Concrete vibrator (petrol)				
8.	Table vibrator (elect./petrol)				
	Equipments for building works				
1.	Block making machine				
2.	Bar bending machine				
3.	Bar cutting machine				
4.	Wood thickness planer				
5.	Drilling machine				
6.	Circular saw machine				
7.	Welding generators				
8.	Welding transformers				
9.	Cube testing machine				
10.	Steel shuttering				
11.	Steel scaffolding				
12.	Grinding/polishing machine				
	Equipments for road works				
1.	Road roller				
2.	Bitumen paver finisher				
3.	Hot mix plant				
4.	Spreaders				
5.	Earth rammers				
6.	Vibratory road roller				
	Equipments for transportation				
1.	Tipper				
2.	Truck				

Place
Date

Signature of the Bidder
(NAME & ADDRESS WITH SEAL)



BHARAT HEAVY ELECTRICALS LIMITED

POWER PLANT PIPING UNIT

THIRUMAYAM- 622 507

CONTRACTS DEPARTMENT

Phone : 04333279551

E.mail : ilango@bheltry.co.in Website : www.bhel.com

Tender No:PPPU:WC:14:015

Tender Notice

Dt. 04.10.2014

	Pneumatic equipments				
1.	Air compressor (diesel)				
	Dewatering equipments				
1.	Pump (diesel)				
2.	Pump (electrical)				
	Power equipments				
1.	Diesel generator				
	Any other plants/equipments				

Note: All / any of the above equipment to be provided within 24 hours of demand.

Place
Date

Signature of the Bidder
(NAME & ADDRESS WITH SEAL)

**BHARAT HEAVY ELECTRICALS LIMITED**

POWER PLANT PIPING UNIT

THIRUMAYAM- 622 507

CONTRACTS DEPARTMENT

Phone : 04333279551

E.mail : ilango@bheltry.co.in Website : www.bhel.com

Tender No:PPPU:WC:14:015

Tender Notice

Dt. 04.10.2014

ANNEXURE – II of PQC**DETAILS OF SIMILAR WORKS COMPLETED DURING THE LAST SEVEN YEARS
(2007-2008 TO 2013-2014)**

Sl. No.	Name of work & Agreement No.	Date of commencement	Date of completion		Reasons for delay & compensation levied, if any	Work order Value	Gross cost of completion		Name, designation & complete address of the authority for whom the work was done
			Stipulated	Actual			Including cost of cement, steel reinforcement & strl. steel	Excluding cost of cement, steel reinforcement & strl. steel	

DETAILS OF WORK : COMPLETION CERTIFICATES, WORK ORDERS ETC. ARE TO BE FURNISHED

Place
DateSignature of the Bidder
(NAME & ADDRESS WITH SEAL)



BHARAT HEAVY ELECTRICALS LIMITED

POWER PLANT PIPING UNIT

THIRUMAYAM- 622 507

CONTRACTS DEPARTMENT

Phone : 04333279551

E.mail : ilango@bheltry.co.in Website : www.bhel.com

Tender No:PPPU:WC:14:015

Tender Notice

Dt. 04.10.2014

ANNEXURE – III of PQC

CLIENT'S CERTIFICATE REGARDING PERFORMANCE OF CONTRACTORS

Name & Address of the Client

.....
.....

Details of works executed by Shri . M/s

1. Name of work with brief particulars :
2. Agreement No. and date :
3. Date of commencement :
4. Stipulated date of completion :
5. Actual date of completion :
6. Details of compensation levied for delay, if any:
7. Tendered amount :
8. Gross amount of the work completed :
9. Name and address of the authority under whom work executed :
10. Whether the contractor employed qualified Engineer/Overseer during execution of work? :
11. (i) Quality of work (indicate grading) : Outstanding/V.Good/Good/Poor
(ii) Amount of work paid on reduced rate basis, if any :
12. (i) Did the contractor go for arbitration ? :
(ii) If yes, amount of claim :
(iii) Amount received :
13. Comments on the capabilities of the contractor
 - (a) Technical Proficiency : Outstanding/V.Good/Good/Poor
 - (b) Financial Soundness : Outstanding/V.Good/Good/Poor
 - (c) Mobilisation of adequate T & P : Outstanding/V.Good/Good/Poor
 - (d) Mobilisation of manpower : Outstanding/V.Good/Good/Poor
 - (e) General behaviour : Outstanding/V.Good/Good/Poor

NOTE: All columns should be filled in properly.

Place
Date

Signature of the Bidder
(NAME & ADDRESS WITH SEAL)



BHARAT HEAVY ELECTRICALS LIMITED

POWER PLANT PIPING UNIT

THIRUMAYAM- 622 507

CONTRACTS DEPARTMENT

Phone : 04333279551

E.mail : ilango@bheltry.co.in Website : www.bhel.com

Tender No:PPPU:WC:14:015

Tender Notice

Dt. 04.10.2014

WORK SPECIFIC TERMS AND CONDITIONS

- 1) **The scope of work includes Construction of foundations for 40T furnace, chimney, blower and blower shed & control room in PPPU of BHEL, Thirumayam.**
- 2) On finalization of Tender, work order will be issued.
- 3) Time is the essence of the contract. Being a time bound work on construction nature, the contractor should make all efforts to complete the work in the stipulated period of 5 months.
- 4) The tender value excludes cost of cement, reinforcement steel & structural steel which will be supplied by BHEL at Stores at free of cost. Other free issue materials by BHEL are indicated in Schedule B of the bid document.
- 5) Tender Value is only approximate and liable for variation without entitling the tenderer to any compensation, till the total value of contract vary by more than 20% (twenty percentage).
- 6) Quoted item rate shall be firm throughout the contract period of 5 months and extended contract period also and no cost escalation is allowed on any account.
- 7) The rates offered are for finished item of works as per drawing and shall provide for the complete cost towards fuel, tools, tackles, plant & machinery, temporary works, labour, materials, **levies, taxes**, transport, lay-out, repairs, rectifications, maintenance till handing over, supervision, labour colonies, establishment, services, roads, revenue expenses, overheads, profits & all other incidentals etc., complete.
- 8) **However if the service tax is applicable for this contract, the same will be reimbursed on production of valid document proof for having paid service tax by the tenderer.**
- 9) The tenderers are advised to visit BHEL Factory at Thirumayam and get themselves acquainted with the site conditions before submitting the offer. BHEL / Thirumayam is located around 20 KM from Pudukottai on Pudukottai – Karaikudi Highway in Tamil Nadu.
- 10) Usually, working hours are limited to day time only. In emergency cases to carryout works during nights, it may be done so with the specific prior permission of BHEL. In such case, it is to be carried out in the presence of BHEL officials or their authorized persons.
- 11) The works executed in the own name of the tenderer only will be considered for eligibility criteria.
- 12) Dissimilar / irrelevant works will not be considered for eligibility criteria.
- 13) Documentary evidences (Xerox copies - attested) for turnover, works experience, P.F, ESI registration etc., all as indicated & required in the tender document should be furnished without which it will not be taken into account.

Place
Date

Signature of the Bidder
(NAME & ADDRESS WITH SEAL)



BHARAT HEAVY ELECTRICALS LIMITED

POWER PLANT PIPING UNIT

THIRUMAYAM- 622 507

CONTRACTS DEPARTMENT

Phone : 04333279551

E.mail : ilango@bheltry.co.in Website : www.bhel.com

Tender No:PPPU:WC:14:015

Tender Notice

Dt. 04.10.2014

- 14) The work shall be carried out as per drawings released then and there, Civil Engineering Department Work & Safety procedure, specifications, standard code of practice and as per the instructions of Engineer-in-charge. The description of items of work are given in Bill of Quantities. **Tenderer has to quote rates for all the items given in Bill of quantities of Price Bid**
- 15) For any item of work not covered in Bill of Quantities, the rate will be arrived at based on the conditions given in BHEL General Conditions of Contract.
- 16) The contractor should bring the construction earth moving machineries like Poclairn, Paver, Road Roller, JCB etc., as and when required for the work without any delay. Also required number of the following tools & Plants / instruments should be brought by the contractor when required.
- Precise Leveling instruments and theodolite.
 - Full load mixture machine along with weigh batcher
 - Petrol / Kerosene driven vibrator/ mechanical vibrator
 - Cube moulds
 - Inter carting vehicle (tractor, hand trolley etc)
 - Welding machine etc.
 - Steel shuttering
 - Pipe scaffolding
- 17) Exclusive lorries to be deployed to clear the debris generated and on no account the debris can be left for more than three days. Otherwise BHEL would clear the debris at the contractor's risk and cost.
- 18) The contractor has to execute any item of work irrespective of the quantity without any reservation till the contract value does not vary more than 20%.
- 19) The contractor has to carry out the work in production shops without affecting the production.
- 20) The decision of Engineer-in-charge shall be final and binding on the contractor regarding clarification of items in this tender schedule.
- 21) The contractor shall strictly adhere to various labour laws in force.
- 22) The contractor shall follow norms of BHEL security system for movement of men & materials including bio-metric system within the complex.
- 23) Since the responsibility for the quality, workmanship and accuracy of any work being carried out under this contract lies with the contractor, the contractor should ensure that no work is done without the presence of contractor's representative at the work spot.
- 24) The contractor has to submit the organization chart of their set up for the works and any change thereafter in the organization set up shall have the prior approval of BHEL.
- 25) Statement of completed works with detailed measurements along with material reconciliation statements shall be submitted by the contractor in the last week of every month for processing bill.

Place
Date

Signature of the Bidder
(NAME & ADDRESS WITH SEAL)



BHARAT HEAVY ELECTRICALS LIMITED

POWER PLANT PIPING UNIT

THIRUMAYAM- 622 507

CONTRACTS DEPARTMENT

Phone : 04333279551

E.mail : ilango@bheltry.co.in Website : www.bhel.com

Tender No:PPPU:WC:14:015

Tender Notice

Dt. 04.10.2014

- 26) The contractor should establish his own fabrication yard, handling facility etc., for which vacant land will be allotted on specific request for which the rent will not be collected.
- 27) The contractor is required to carry out construction activities as directed by the department officials. It is required to engage certain minimum strength of staff for effective supervision of works as indicated below:
- | | | |
|--|---|-------|
| Civil Engineer (Graduate in Civil Engineering) | - | 1 No. |
| Supervisor/Engineer (Diploma in Civil Engineering) | - | 1 No. |
- 28) Qualified Safety Engineer should be deployed at site whenever necessary.
- 29) To safeguard the persons working at height in roof, wall etc., sufficient number of Industrial Safety nets shall be provided at tenderer's cost in appropriate level and locations. The working hand including Supervisors, Engineers should wear the personal protective items and safety measures such as helmets, safety belts, shoes, etc., before entering into working place.
- 30) The tenderer has to deploy adequate labour of required categories such as Unskilled, Skilled, Mason, Carpenter, Welder, Fitter, Mistry, Technically experienced, etc. so as to execute the works simultaneously in all areas of work. The Technical persons with experience shall have to produce valid certificate for verification.
- 31) Expert labour only to be engaged for specialised items of work like laying of ceramic tiles, marbles, cuddapah slabs, granite slabs and false ceiling, partition, wall paneling, architectural finishing etc. and work experienced persons shall be engaged for fabrication work, etc.
- 32) Exclusive Stores personnel should be engaged who would co-ordinate with department official for clearance and collection of BHEL supplied materials required for works.
- 33) Separate non-technical persons should be engaged for arranging daily gate passes for labours and vehicles entry in all the gates of Factory Complex.
- 34) The tenderer shall carry out health performance test at his cost for all the workmen engaged in the work through a registered medical practitioner and produce certificate on demand.
- 35) Canteen facilities will be provided for contractor's workmen at subsidized rates inside the factory.
- 36) All the works shall be executed as per the standard specifications as provided in BOQ / TNBP / BIS.
- 37) The works contract to be entered into with the successful tenderer will be governed by the BHEL Revised General Conditions of Contract in force.
- 38) All the materials to be used in the work and the nature of work shall conform to the respective TNBP & BIS and National Building Organisation, Standard Specifications forming part of "ALL INDIA STANDARD SCHEDULE OF RATES" specifications and shall be got approved by the Engineer-in-charge before actual incorporation in the work.
- 39) The contractor should maintain proper accounts for cement, reinforcement steel and structural steel sections and other materials if any supplied by this organisation and these

Place
Date

Signature of the Bidder
(NAME & ADDRESS WITH SEAL)



BHARAT HEAVY ELECTRICALS LIMITED

POWER PLANT PIPING UNIT

THIRUMAYAM- 622 507

CONTRACTS DEPARTMENT

Phone : 04333279551

E.mail : ilango@bheltry.co.in Website : www.bhel.com

Tender No:PPPU:WC:14:015

Tender Notice

Dt. 04.10.2014

should be available at the site of work for verification and check by the Officials of this Organisation at any time.

- 40) All tools and plants including jack hammer with silencer & bits, rock drilling machine, etc., required for all the works covered under this contract will have to be brought by the contractor.
- 41) All safety measures are to be followed during execution of work, particularly during blasting and only licensed blaster should be engaged for this purpose. Sufficient care shall be taken by the contractor during excavation to avoid damages to the buried pipe lines, cables and other infrastructure like railway lines if any etc. Controlled blasting including muffling can be carried out with prior permission from safety department.
- 42) **The contractor should use only the materials of brand and quality as approved by BHEL.**
- 43) The contractor should submit the list of machineries and site personnel to be deployed for the work along with tender.
- 44) All materials and consumables brought by the contractor should have manufacturer's certificate.
- 45) The contractor should use only weigh batch for all reinforced cement concrete works (controlled concrete). The tenderer is advised to install concrete mini batching plant at site if required.
- 46) Contractor's materials and tools & plants shall have to be brought inside factory with proper invoice / voucher and make necessary entry in the security gate. They should maintain proper record for tools and plants, materials, etc., brought inside the factory complex.
- 47) The contractor should submit the mix design for RCC for different mix of concrete for different grade of cement at his cost through reputed institution.
- 48) The contractor should extend fullest co-operation with the third party agencies engaged, if any by BHEL to adhere the Quality Control Procedures ensuring quality.
- 49) The contractor should extend full co-operation to the other contractors who may be doing other works in the same areas to enable them to execute their portions of work without any delay or difficulty.
- 50) With regard to specifications not covered by the General and Special Conditions of Contract, those contained in the CPWD specifications or other specifications approved by Bharat Heavy Electricals Limited, shall apply.
- 51) Purchase preference policy if applicable will be extended to CPSE bidders subject to other terms & conditions as provided in the office memorandum issued by DPE. The tenderer has to furnish copy of Government circular for claiming purchase preference.
- 52) Tenderers are requested to furnish the duly filled in E format attached as separate sheet along with a cancelled cheque leaf to accept Electronic fund transfer / R T G S transfer for any payment from BHEL, Trichy.
- 53) Bank Guarantee format can be obtained after award of work by the successful tenderer.

Place
Date

Signature of the Bidder
(NAME & ADDRESS WITH SEAL)



BHARAT HEAVY ELECTRICALS LIMITED

POWER PLANT PIPING UNIT

THIRUMAYAM- 622 507

CONTRACTS DEPARTMENT

Phone : 04333279551

E.mail : ilango@bheltry.co.in Website : www.bhel.com

Tender No:PPPU:WC:14:015

Tender Notice

Dt. 04.10.2014

- 54) No advance / mobilization advance will be given.
- 55) LD/Penalty clause is applicable as per General Conditions of Contract. All the terms & conditions in the documents are binding on the tenderers.
- 56) BHEL also reserves its right to reject a tender due to unsatisfactory past performance in the execution of any contract at another project / Unit awarded against a different enquiry.
- 57) Also BHEL reserves its right to finalize the contract through reverse auction for which only qualified tenderers will be provided with necessary documents containing reverse auction rules, terms and conditions for this purpose.
- 58) Tender without EMD / one time EMD will be summarily rejected and the technical bid & price bid shall not be considered.
- 59) The correspondence exchanged against the tender from both tenderer and BHEL through email are considered as valid document legally though it is not signed. It is treated as valid confirmations made on behalf of the respective company and very much comes under the legal ambit of the business transaction and hence it is binding on both the parties.
- 60) The works contract to be entered in to with the contractor will be governed by the BHEL Revised General Conditions of contract in force.
- 61) Should a tenderer find discrepancies or omissions in the drawings or any of the tender documents or should be in doubt as to their meaning, he should at once address the authority inviting the tender for clarification. Every endeavour is made to avoid any error which can materially affect the basis of the tender but the successful tenderer shall take upon himself to provide for the risk of any error which may be subsequently discovered and shall make no subsequent claim on account thereof.
- 62) Tenders submitted by post / courier should be posted with due allowance for any delay in postal delivery. Tenders received after the due date and time of opening, tenders are liable to be rejected.
- 63) Where the tender called for covers only the building work and excludes internal services such as sanitary and water supply installations, electrification etc., the building contractor will have to leave pockets, holes, etc., as required for other works and will have to phase his work to ensure smooth progress of the work of the other agencies also as directed by the Engineer – in – charge.
- 64) Where the tender schedule contains special items of work such special floor finishes, foam concrete for insulation, special water proofing treatment to roofs etc., it will be entirely at the discretion of the Project Authorities to allot these items of work to other contractors specialized in these works. In such cases, the main building Contractor will have to tender all necessary co-operation to the agencies involved so as to ensure the smooth progress of all work.
- 65) The contractor's responsibility under this tender shall commence from the date of receipt of Contract / LOI from BHEL.
- 66) Generally, the maintenance period (guarantee for material provided and workmanship) for any work under BHEL Organisation will be SIX (6) MONTHS.

Place
Date

Signature of the Bidder
(NAME & ADDRESS WITH SEAL)



BHARAT HEAVY ELECTRICALS LIMITED

POWER PLANT PIPING UNIT

THIRUMAYAM- 622 507

CONTRACTS DEPARTMENT

Phone : 04333279551

E.mail : ilango@bheltry.co.in Website : www.bhel.com

Tender No:PPPU:WC:14:015

Tender Notice

Dt. 04.10.2014

- 67) Should a tenderer or a contractor on the list of approved Contractors have a relative, or in the case of a firm or Company of contractors any of its shareholders or shareholder's relative, employed in a gazetted capacity in the Engineering Department of the Bharat Heavy Electricals Limited, the authority inviting tenders shall be informed of this fact at the time of submission of the tender, failing which tender, may be disqualified or if such fact subsequently comes to light, the contract may be rescinded in accordance with the relevant provisions in the General Conditions of Contract.
- 68) If tenderer expires after the submission of his tender or after the acceptance of his tender the BHEL may, at their discretion, cancel such tender. If a partner of a firm expires after submission of tender or after the acceptance of the Tender, BHEL may cancel such Tender at their discretion unless the firm retain its character.
- 69) Bharat Heavy Electricals Limited will not be bound by any power of attorney granted by the tenderer or by changes in the composition of firm made subsequent to the execution of the contract. They may however recognize such power of attorney and changes after obtaining proper legal advice the cost of which will be chargeable to the contract concerned.
- 70) If the tenderer deliberately gives wrong information in the tender or creates conditions favourable for the acceptance of his tender, the Bharat heavy Electricals Limited, reserves the right to reject such tender at any stage.
- 71) Words importing the singular number shall also be deemed to include the plural number and vice versa where the context so requires.
- 72) The expenses for completing and stamping the agreement shall be paid by the contractor.
- 73) The General and special conditions are complementary to each other and where they are conflict the Special Conditions shall prevail. In regard to matters not covered by the General and Special Conditions of Contract, those contained in the CPWD Standard Specifications or other specifications approved by the Bharat Heavy Electricals Limited, shall apply.
- 74) Tenderers shall not increase their quoted rates in case the Bharat Heavy Electricals Limited, negotiates for reduction of rates. Such negotiation shall not amount to cancellation or withdrawal of the original offer and the rates originally quoted shall be binding on the tenderers for a period of three months from the date of opening of tenders.
- 75) Canvassing in any form in connection with tenders is strictly prohibited and the tenders submitted by the contractors who resort to canvassing will be liable to rejection.
- 76) All contractors will have to produce Income tax Clearance Certificate from the Income Tax-Officer concerned along with their tenders. Those Contractors whose income is not taxable will be required to give an affidavit of their income on the prescribed form. If the successful tenderer fails to produce the Income – tax clearance certificate within the stated period the Earnest Money Deposit and Security Deposit of the tenderer may be forfeited and the contract terminated.
- 77) No night work will be permitted without the written permission of the Engineer – in – charge.

Place
Date

Signature of the Bidder
(NAME & ADDRESS WITH SEAL)



BHARAT HEAVY ELECTRICALS LIMITED

POWER PLANT PIPING UNIT

THIRUMAYAM- 622 507

CONTRACTS DEPARTMENT

Phone : 04333279551

E.mail : ilango@bheltry.co.in Website : www.bhel.com

Tender No:PPPU:WC:14:015

Tender Notice

Dt. 04.10.2014

- 78) Bulkage test on the sand to be used on the work should be conducted periodically to arrive at the correct quantity of sand to be mixed for the different proportions as and when required.
- 79) Items of work other than those mentioned in the Bill of Quantities (Tender Schedule) attached hereto will be carried out at the rates to be fixed by this organization as per relevant clauses of the General Conditions of Contract.
- On the written request from the contractor **Water required for the work may be provided by this organization at only one point at the site of the work at free of cost.** In case of failure of water supply, the Contractor will have to make his own arrangements for water without any extra claims until supply is restored. BHEL does not accept any liability whatsoever for non-supply or delay in the supply of water under any circumstances. The contractor shall ensure that there is no wastage of water otherwise supply of water, is liable to be stopped at contractor's risk and cost.
 - On the written request from the contractor **Electrical energy required for the work may be given by this organization at any one point at the site of work at free of cost.** BHEL does not accept any liability whatsoever for non-supply, delay in supply or failure of supply of electrical energy. Contractor shall ensure that there is no wastage of electrical energy otherwise supply is liable to be stopped at contractor's risk and cost. The contractor shall make leak proof / fire proof shed and provide control panel board of required capacity and lay the required cables at their own cost for further distribution.
 - On the written request from the contractor **Compressed air alone will be provided this organization at only one point near the site of work at free of cost. The contractor has to provide further arrangements from that point to his other areas. Also** the contractor should be in a position to make his own arrangement for compressed air without any extra claim for the uninterrupted operation of jack hammer with silencer wherever BHEL is not in a position to supply compressed air.
- 80) Permission for erection of temporary work sheds etc., at site will have to be obtained from BHEL in writing in advance.
- 81) The works contract to be entered into with the successful tenderer will be governed by the BHEL revised General Conditions of Contract in force.
- 82) The successful tenderer / Contractor shall observe all safety regulations and take necessary safety precaution as called for under the "Terms & Conditions related to Safety" enclosed herewith.
- 83) In all matters of dispute, the decision of the General Manager, Bharat Heavy Electricals Ltd., Thirumayam – 622 507. shall be final and binding on the tenderer / contractor.
- 84) Unless otherwise indicated in the Bill of Quantities cement, reinforcement steel (MS rods, CTD bars etc.), structural steel sections and other items (as mentioned in Schedule B) will be issued at BHEL Stores at free of cost. The Contractor's quoted rates shall therefore be inclusive of the cost of conveyance of these items from BHEL Stores to site of work

Place
Date

Signature of the Bidder
(NAME & ADDRESS WITH SEAL)



BHARAT HEAVY ELECTRICALS LIMITED

POWER PLANT PIPING UNIT

THIRUMAYAM- 622 507

CONTRACTS DEPARTMENT

Phone : 04333279551

E.mail : ilango@bheltry.co.in Website : www.bhel.com

Tender No:PPPU:WC:14:015

Tender Notice

Dt. 04.10.2014

including, loading, unloading and other incidental costs etc. The quantities of each items to the extent required for actual incorporation of the work will be treated as ISSUED FREE OF COST.

85) CEMENT:

Excess consumption of cement over and above the theoretical requirement as per BHEL Data upto a limit of 5% will be charged at the rate of Rs.6,668/per M.T. + applicable taxes at the time of recovery. Consumption beyond 5% will be charged at the punitive recovery rate of Rs.13,336/per M.T.. + applicable taxes at the time of recovery.

The above rates are only indicative and BHEL issue rate on date of actual issue will be applied

Gunny bags or Polythene Bags or Paper Bags in which cement is issued from BHEL Stores, need not be returned by Contractor to BHEL. The cost for each empty cement bag will be recovered from the Contractor's bills at the following rates.

i.	Empty cement gunny bag	Rs.1.25 + ST and SC / each
ii	Empty Polythene bag	Rs. 0.50 + ST and SC / each
iii	Empty paper bag	Rs. 0.25+ST and SC / each.

86) REINFORCEMENT STEEL:

All surplus reinforcement rod with the contractor shall be returned to BHEL Stores at his own cost in the form of full lengths, useful cut bits and scrap. The invisible (non-returnable) wastage should not exceed a maximum of 0.5% of the actual quantity consumed in the work.

The contractor shall return all the scrap to the disposal stores at his own cost. Bent rods will also be taken as scrap only, irrespective of their length. The maximum permissible limit of scrap without recovery is 5% of actual consumption. The recovery details for the materials are as follows:

a)	Single recovery rate for the non returned scrap upto 5% of actual consumption	:	Rs.49,547/- per M.T + applicable taxes at the time of recovery
b)	The punitive recovery rate for steel qty. not accounted and extra scrap generated beyond 5% of actual consumption	:	Rs.99,095/- per M.T. + applicable taxes at the time of recovery

The above rates are only indicative and BHEL issue rate on date of actual issue will be applied.

87) STRUCTURAL STEEL SECTIONS:

All surplus raw steel remaining with the contractor shall be returned to BHEL stores at his own cost after completion of fabrication, in the form of full lengths, useful cut bits and scrap. The following yardstick will be adopted for the purpose of classification of scrap.

(a) Mild steel and alloy	1000X500mm and above	Useful cut bit
--------------------------	----------------------	----------------

Place
Date

Signature of the Bidder
(NAME & ADDRESS WITH SEAL)



BHARAT HEAVY ELECTRICALS LIMITED

POWER PLANT PIPING UNIT

THIRUMAYAM- 622 507

CONTRACTS DEPARTMENT

Phone : 04333279551

E.mail : ilango@bheltry.co.in Website : www.bhel.com

Tender No:PPPU:WC:14:015

Tender Notice

Dt. 04.10.2014

Steel plates and sheets		
(b) Mild steel and alloy Steel plates and sheets	Less than 1000 X 500 mm	Scrap
(c) Structural	One metre and above in length	Useful cut bits
(d) Structural	Less than one metre in length	Scrap

The invisible (Non-returnable) wastage should not exceed a maximum of 2% by weight of fabricated steel work and returnable wastage generated by way of scrap or useful cutbits shall be returned at "Actuals". Maximum permissible limit for scrap without recovery shall be 5% of actual fabricated quantity. However every care should be taken to see that raw steel is utilised most economically by preparing necessary cutting lists to restrict the scrap within the permissible limit.

Should the quantum of invisible wastage exceed the 2% permissible limit, RECOVERY AT TWO TIMES OF THE VALUE OF the extra tonnage involved (which will be evaluated on an average cost per tonne basis considering the total raw steel materials issued) will be effected from the contractor for the excess quantity involved (**2 times x Rs. 48,495 = Rs.96,990 / MT + applicable taxes at the time of recovery**).

The above rates are only indicative and BHEL issue rate on date of actual issue will be applied.

The Contractor shall submit a material tallying statement on completion of the work indicating the details of quantities of each material (section by section) received quantities used for fabrication as per DOD lists. Quantity returned in full length, useful cut bits and scrap and the quantity reckoned as invisible wastage.

i) For Structural Steel:

- a) Single recovery rate for the non returned scrap upto 5% of actual consumption : Rs.48,495/- per M.T + applicable taxes at the time of recovery
- b) The punitive recovery rate for steel qty. not accounted and extra scrap generated beyond 5% of actual consumption : Rs.96,990/- per M.T. + applicable taxes at the time of recovery

ii) For Rails:

- a) Single recovery rate for the non returned scrap upto 5% of actual consumption : Rs.65,739/- per M.T + applicable taxes at the time of recovery
- b) The punitive recovery rate for steel qty. not accounted and extra scrap generated beyond : Rs.1,31,478/- per M.T. + applicable taxes at the

Place
Date

Signature of the Bidder
(NAME & ADDRESS WITH SEAL)



BHARAT HEAVY ELECTRICALS LIMITED

POWER PLANT PIPING UNIT

THIRUMAYAM- 622 507

CONTRACTS DEPARTMENT

Phone : 04333279551

E.mail : ilango@bheltry.co.in Website : www.bhel.com

Tender No:PPPU:WC:14:015

Tender Notice

Dt. 04.10.2014

5% of actual consumption

time of recovery

iii) For ERW Tubes:

- a) Single recovery rate for the non returned scrap upto 5% of actual consumption : Rs.42,534/- per M.T + applicable taxes at the time of recovery
- b) The punitive recovery rate for steel qty. not accounted and extra scrap generated beyond 5% of actual consumption : Rs.85,068/- per M.T. + applicable taxes at the time of recovery

iv) For Seamless Steel Tubes:

- a) Single recovery rate for the non returned scrap upto 5% of actual consumption : Rs.1,23,260/- per M.T + applicable taxes at the time of recovery
- b) The punitive recovery rate for steel qty. not accounted and extra scrap generated beyond 5% of actual consumption : Rs.2,46,520/- per M.T. + applicable taxes at the time of recovery

The above rates are only indicative and BHEL issue rate on date of actual issue will be applied.

- 88) The Manager / Civil or his duly authorized representative shall have all reasonable times access to Contractor's premises of work and shall have the power at all the reasonable times to inspect and test any portion of the work or examine the materials and workmanship of the structures during their manufacture and test. The contractor shall give due notice in writing to the Inspecting Engineer of BHEL when the materials supplied to be incorporated in the work are ready for inspection and test. No material shall be incorporated in the work until the inspecting Engineer certified in writing that such materials have been inspected and approved by him.
- 89) The Contractor shall closely scrutinize all the drawings issued in connection with the work by this organization and bring to the notice of the Engineer-in-charge if any discrepancies, omissions in the drawings before undertaking the actual work pertaining thereto.
- 90) The contractor should submit in advance every fortnight a detailed program of work to be undertaken from time to time strictly in conformities with the "Time and Progress Chart" covering the entire constructed work and reschedule them wherever necessary during the progress of the work so as to achieve the target set. Periodical progress reports of every fortnight should also be furnished by the Contractor regarding the collection of materials issued and to be issued from BHEL Stores and other relevant information as asked for by the Engineer-in-charge and other BHEL Officers-in-charge of the work.
- 91) Tools and Plants on site: All tools, plants and equipment brought to the site shall become the property of B.H.E.L and shall not be removed from the site without the prior written

Place
Date

Signature of the Bidder
(NAME & ADDRESS WITH SEAL)



BHARAT HEAVY ELECTRICALS LIMITED

POWER PLANT PIPING UNIT

THIRUMAYAM- 622 507

CONTRACTS DEPARTMENT

Phone : 04333279551

E.mail : ilango@bheltry.co.in Website : www.bhel.com

Tender No:PPPU:WC:14:015

Tender Notice

Dt. 04.10.2014

approval of the Engineer-in-charge. When the work is finally completed or the Contract is determined for reasons other than the default of the Contractor he shall forthwith remove from the site all tools, plants, equipments etc., (other than those as may have been provided by B.H.E.L) and upon such removal, the same shall in, and become the property of the Contractor.

- 92) Statement of Hire Charges: A monthly detailed statement of the hire charge incurred in respect of B.H.E.L tools, plants, equipments etc., shall be given to the Contractor by the Engineer-in-charge.
- 93) Precaution Against risks:
- The Contractor shall be responsible for providing at his own expense, for all precautions to prevent loss or damage from any and all risks and to minimize the amount of any such loss or damage and for the necessary steps to be taken for the said purpose until the works have been handed over complete in all respect of the Engineer-in-charge.
 - The Contractor shall provide all watchmen necessary for the protection of the site, the work, the materials, tools, plants, equipments and anything else lying on the Site during the progress of the work. He shall be solely responsible for and shall take all reasonable and proper steps for protecting, securing, lighting and watching, all places on or about the work and the Site which may be dangerous to any person whomsoever.
- 94) Notices and Fees: The Contractor shall give all notices required by any Statutory provision or by the regulations and/or bylaws of any local Authority and/or of any Public Service, Company or Authority affected by the work or with whose system the same are or will be connected. The Contractor shall pay and indemnify B.H.E.L against any fees and charges payable under such Acts. Regulation and/or bylaws in respect of the work and shall make and supply all drawings and plans required in connection with any such notice.
- 95) Setting out of the Works and Protective and Maintaining Signals and Works:
- The Engineer-in-charge shall supply dimensioned drawings, levels and other information necessary to enable the contractor to set out the work. The Contractor shall at his own expense set accurately according to the drawings and figured dimension thereon, all the work comprised in the contract and any extras or additions there-to and shall be solely responsible for their being so set out and executed. All bench marks, pegs, signals on the surface, alignment stones, milestones and all similar marks whether put in by B.H.E.L Authorities for the purpose of checking the Contractor's work or in the nature of permanent survey marks will during the tenure of the contract, be under the care of the Contractor who shall, at his own expense, take,all proper and reasonable precautions and care to preserve and maintain them in their true position. In the event of these marks being disturbed or obliterated by accident or due to any other cause whatsoever, the same may, if deemed necessary, be replaced by the Engineer-in-charge at the Contractor's expense and the cost thereof deducted from any money then or thereafter becoming due to the Contractor.

Place
Date

Signature of the Bidder
(NAME & ADDRESS WITH SEAL)



BHARAT HEAVY ELECTRICALS LIMITED

POWER PLANT PIPING UNIT

THIRUMAYAM- 622 507

CONTRACTS DEPARTMENT

Phone : 04333279551

E.mail : ilango@bheltry.co.in Website : www.bhel.com

Tender No:PPPU:WC:14:015

Tender Notice

Dt. 04.10.2014

- b. Where requested by the Contractor, the level marks, center line and chainage pegs corresponding to those shown on the Drawing will be pointed out to the Contractor on the ground but all bench marks or chainage pegs additional to those shown on the Drawing will be set out by BHEL authorities.
- 96) Site Drainage: All water that may accumulate on the site during the progress of the work or in trenches and excavations shall be removed to the entire satisfaction of the Engineer-in-charge and at Contractor's expense.
- 97) Excavations, Relics Etc.: Material of any kind obtained from excavation on the site shall remain the property of BHEL and shall be disposed off as Engineer-in-Charge directs.
- 98) All gold, silver, oil and other minerals of any description and all precious stones, coins, treasures, relics, antiques and other similar items which may be found in or upon the site shall be the property of Bharat Heavy Electricals Limited and the Contractor shall duly preserve the same to the satisfaction of the BHEL and shall from time to time deliver the same to such person or persons as the B.H.E.L may appoint to receive the same.
- 99) Foundations: The Contractor shall not lay any foundations until the excavations for the same have been examined and approved in writing by the Engineer-in-charge.
- 100) Covering-in Work: The Contractor shall give reasonable notice in writing to the Engineer-in-charge whenever any work is to be permanently covered up or concealed, whether by earth or other means so that it can finally be inspected or measured if necessary. In default of so doing, the Contractor shall, if required by the Engineer-in-charge uncover such work at his own expense.
- 101) Approval of works by Stages: All work embracing more than one process shall be subject to examination and approval at each stage thereof and the Contractor shall give due notice in writing to the Engineer-in-charge when each stage is ready. In default of such notice being received, the Engineer-in-charge shall be entitled to approve the quality and extent thereof at any time he may choose and in the event of any dispute, the decision of the Engineer-in-charge thereon shall be final and conclusive.
- 102) Execution of the Work:
- a. The work shall be executed in a workman-like manner and to the satisfaction in all respects of the Engineer-in-charge.
- b. The Engineer-in-charge will communicate or confirm his instructions to the Contractor in respect of the execution of the Work in a "Work Site Order Book" maintained at his office and the Contractor shall visit this office daily and shall confirm receipt of such instructions by signing the relevant entries in this book. Such entries will rank as order or notices in writing within the intent and meaning of these conditions.
- 103) Day Work:
- a. No day-work shall be performed without the prior written instructions of the Accepting Officer.

Place
Date

Signature of the Bidder
(NAME & ADDRESS WITH SEAL)



BHARAT HEAVY ELECTRICALS LIMITED

POWER PLANT PIPING UNIT

THIRUMAYAM- 622 507

CONTRACTS DEPARTMENT

Phone : 04333279551

E.mail : ilango@bheltry.co.in Website : www.bhel.com

Tender No:PPPU:WC:14:015

Tender Notice

Dt. 04.10.2014

- b. The Contractor shall give to the Engineer-in-charge reasonable notice of the start of any work ordered to be executed by day-work and shall deliver to the Engineer-in-charge within two days of the end of each pay week a return in duplicate giving full detailed accounts of labour and materials for that pay-week. One copy of each of these returns, if found correct, will be certified by the Engineer-in-charge and returned to the contractor and must be produced at the time of adjustment of accounts.
- c. An invoice in duplicate signed by the Contractor or his agent shall be sent with each delivery of materials for day-work and the Contractor will be furnished with a receipt signed by the Engineer-in-charge specifying the description, quantities weight or measurement (as the case may be) of the articles approved, reference will be made in this receipt in the return aforesaid and the Contractor's Bill.
- 104) Inspection of the Work: B.H.E.L Officers concerned with the Contract shall have power at any time to inspect and examine any part of the work and the Contractor shall give such facilities as may be required to be given for such inspection and examination Should Engineer-in-charge consider, at any time during the expiry of the maintenance period, that any work has been executed with unsound, imperfect or unskilled workmanship or of a quality inferior to that contracted for or not otherwise in accordance with the contract (in respect) whereof the decision of the Engineer-in-charge shall be final and conclusive the Contractor shall on demand in writing from the Engineer-in-charge specifying the fault notwithstanding that the same may have been inadvertently passed, certified and paid for, forthwith rectify or remove and reconstruct the work so specified in whole or in part as the case may be required at his own expense to the entire satisfaction of the Engineer-in-charge and in the event of his failing to do so within a period to be specified by the Engineer-in-charge in his demand as aforesaid, the Engineer-in-charge may carry out the work by other means at the risk and expense in all respects of the Contractor. However, the liability of the Contractor under this condition shall not extend beyond the maintenance period except as regards workmanship which the Engineer-in-charge shall have previously given notice to the Contractor to rectify.
- 105) Responsibility for Building: In the event of any building or part of any building being handed over to the Contractor for the execution of work thereto under the provisions of the Contract, he shall give a written receipt for all fixtures, glass etc. and he shall be required to make good at his own expense all damages resulting from any cause whatsoever while in his charge and on completion of the work to deliver the said building or part thereof in a clean state complete in every particular to the entire satisfaction of the Engineer-in-charge.
- 106) Insurance:
- a. The contractor shall within one month after the date of the acceptance of the contract, insure the work against loss or damage to the contract works, temporary work and materials erected in performance of the contract on "all risks" basis from the time of arrival on site until taken over by BHEL on completion of the contract.

Place
Date

Signature of the Bidder
(NAME & ADDRESS WITH SEAL)



BHARAT HEAVY ELECTRICALS LIMITED

POWER PLANT PIPING UNIT

THIRUMAYAM- 622 507

CONTRACTS DEPARTMENT

Phone : 04333279551

E.mail : ilango@bheltry.co.in Website : www.bhel.com

Tender No:PPPU:WC:14:015

Tender Notice

Dt. 04.10.2014

- b. The cover shall also include wherever necessary the risks of testing including breakdown or explosion of plant and machinery undergoing testing, trial and commissioning operations. The insurance shall also specifically cover removal of debris cost. The sum insured shall represent the estimated full value of the contract works inclusive of value of free supply materials by BHEL, transport charges, customs dues, express freight, overtime charges, cost of erection, value of constructional plants and machinery, removal of debris and escalation of costs where the contract includes a maintenance period, the insurance cover shall specifically include the contractors' liabilities during the maintenance period. The insurance shall also be extended to cover third party personal injury and property damage for a sum to be specified by BHEL. The insurance shall be effected in the name of BHEL and the contractor shall submit to BHEL a draft of the insurance policy for approval. The policy when issued will be lodged with BHEL together with receipts of premium for such insurance and the contractor shall maintain such policies in force until the obligations of the contractor are fully discharged.
- c. If the contractor fails to comply with the terms of this condition the Accepting officer may insure the work and may deduct the amount of premiums from any money that may become payable to the contractor or may at his discretion refuse payment of any advances to the contractor until the contractor shall have complied with the terms of this condition. This provision does not, however, absolve the contractor of his responsibility for taking up the insurance. The contractor is, therefore, primarily responsible for taking up the insurance in time.
- 107) Damage and loss to private property and injury to workmen: The contractor shall at his own expense reinstate and make good to the satisfaction of the Engineer-in-charge and pay compensation for any injury, loss or damage occasioned to any property or rights whatever including property and rights of B.H.E.L, (or agents, servants or employees of B.H.E.L) the injury loss or damage arising out of or in anyway in connection with the execution or purported execution of the contract and further the contractor shall indemnify B.H.E.L, against all claims enforceable against B.H.E.L, or any agent, servant, or employee of B.H.E.L a private person, in respect of any such injury (including injury resulting in death loss or damage to any person) whosoever or property, including all claims which may arise under the workmen's Compensation Act or otherwise, or which would be enforceable against B.H.E.L.
- 108) Completion:
- a. The works shall be completed to the entire satisfaction of the Engineer-in-charge and in accordance with the Contractor's forecast of Time and Progress where operative, and all unused stores and materials, tools, plants, equipments, temporary buildings and things shall be removed and the site and work cleared of rubbish and all waste materials and delivered up clean and tidy to the satisfaction of the Engineer-in-charge at the Contractor's expense and/or before the Scheduled date of completion.

Place
Date

Signature of the Bidder
(NAME & ADDRESS WITH SEAL)



BHARAT HEAVY ELECTRICALS LIMITED

POWER PLANT PIPING UNIT

THIRUMAYAM- 622 507

CONTRACTS DEPARTMENT

Phone : 04333279551

E.mail : ilango@bheltry.co.in Website : www.bhel.com

Tender No:PPPU:WC:14:015

Tender Notice

Dt. 04.10.2014

- b. The B.H.E.L shall have power to take over from the Contractor from time to time each sections of the work as have been completed to the satisfaction of the Engineer-in-charge.
- c. In case the Contractor fails to remove any of his properties, assets or fails to clear the rubbish and waste materials within 30 days of the completion of the contract, it is lawful for the contractee, that is BHEL to take such action as it deems fit to clear dispose of such properties, assets or such waste materials and charge the contractor any expenses incurred thereon.
- d. The Engineer-in-charge shall certify to the Contractor the date on which the work is completed and the state thereof.
- e. The Engineer-in-charge shall also certify to the Contractor the state of the work at the end of maintenance period, where applicable.

109) Compensation for Delay: If the contractor fails to maintain the required progress or to complete the work and clear the site on or before the contracted or extended period of completion, he shall, without prejudice to any other right or remedy of the B.H.E.L on account of such breach, pay as agreed compensation an amount calculated as stipulated below or such smaller amount as may be fixed by the BHEL on the contract value of the work for every week that the progress remains below that is required or that the work remains incomplete.

This will also apply to items or group of items for which separate period of completion has been specified. For this purpose the term 'Contract Value' shall be the value at contract rates of the work as ordered.

- a. Completion period (as originally-stipulated) -- at 1 percent per week.
Not exceeding 6 months.
- b. Completion period (as originally-stipulated) -- at ½ percent per week
Exceeding 6 months and not exceeding 2 years.
- c. Completion period (as originally-stipulated) -- at ¼ percent per week
Exceeding 2 years.

Provided always that the total amount of compensation for delay to be paid under this condition shall not exceed the under noted percentage of the contract value or of the contract value of the item or group of items of work for which a separate period of completion is given:

- a. Completion period (as originally-stipulated) -- 10 percent.
Not exceeding 6 months.
- b. Completion period (as originally-stipulated) -- 7½ percent.
Exceeding 6 months and not exceeding 2 years.
- c. Completion period (as original-stipulated) -- 5 percent.
Exceeding 2 years

Place
Date

Signature of the Bidder
(NAME & ADDRESS WITH SEAL)



BHARAT HEAVY ELECTRICALS LIMITED

POWER PLANT PIPING UNIT

THIRUMAYAM- 622 507

CONTRACTS DEPARTMENT

Phone : 04333279551

E.mail : ilango@bheltry.co.in Website : www.bhel.com

Tender No:PPPU:WC:14:015

Tender Notice

Dt. 04.10.2014

The amount of compensation may be adjusted or set-off against any sum payable to the Contractor under this or any other contract with the B.H.E.L.

110) Laws Governing the Contract: This contract shall be governed by the Indian Laws for the time being in force.

111) Cancellation of Contract for Corrupt Acts: The Accepting Officer, whose decision shall be final and conclusive, shall, without prejudice to any other right or remedy which shall have accrued or shall accrue thereafter to Bharat Heavy Electricals Limited, cancel the contract in any of the following cases and the Contractor shall be liable to make payment to B.H.E.L for any loss or damage resulting from any such cancellation for default. If the Contractor shall:

- a. Offer or give or agree to give to any person in BHEL service any gift or consideration of any kind as an inducement or reward for doing or for bearing to do or for having done or forborne to do a day act in relation to the obtaining or execution of this or any other contract for BHEL service OR
- b. Enter into a contract with B.H.E.L in connection with which commission has been paid or agreed to be paid by him or with his knowledge, unless the particulars of any such commission and the terms of payment thereof have previously been disclosed in writing to the Accepting Officer, OR
- c. Obtain a contract with B.H.E.L as a result of ring tendering or by non-bonafide methods of competitive tendering without first disclosing the fact in writing to the Accepting Officer.

112) Records and Measurements:

- i) All items having a financial value shall be entered in the B.H.E.L Measurement Book so that a complete record is obtained of all works performed under the Contract.
- ii) Buildings, etc., priced in Schedule 'A' as a unit lumpsum will be entered by number at the unit lumpsum. Work carried out for agreed lumpsum will be described and similarly recorded.
- iii) Lumpsum omissions will be entered for deduction. Measurement shall be restricted to that required to ascertain the financial liability of B.H.E.L under the contract.
- iv) Work which fails to be measured in detail shall be measured physically, without reference to any local custom that may obtain excepting where it may otherwise be directed in the tender documents. The measurements shall be taken jointly by any person duly authorized on the part of the BHEL and by the Contractor.
- v) The Engineer-in-charge shall give reasonable notice in writing to the Contractor of appointment for measurement.
- vi) The Contractor shall, without extra charge, provide assistance with appliance and other things necessary for measurement.
- vii) The Contractor shall bear all the cost of measurement of his work.
- viii) Measurement shall be entered in the B.H.E.L Measurement Book and signed and dated by both parties each day at the Site on completion of measurement. If the Contractor objects to any of the measurements recorded on behalf of the B.H.E.L a note to that

Place
Date

Signature of the Bidder
(NAME & ADDRESS WITH SEAL)



BHARAT HEAVY ELECTRICALS LIMITED

POWER PLANT PIPING UNIT

THIRUMAYAM- 622 507

CONTRACTS DEPARTMENT

Phone : 04333279551

E.mail : ilango@bheltry.co.in Website : www.bhel.com

Tender No:PPPU:WC:14:015

Tender Notice

Dt. 04.10.2014

effect will be made in the BHEL Measurement Book or against the item or items objected to; and such note shall be signed and dated by both the parties engaged in taking the measurement.

- ix) If, as a result of such objection, it becomes necessary to re-measure the work wholly or in part, the expense of such re- measurement shall be borne by the party requiring the measurement.
- x) Measurement to be re-taken, provided that a net error is found by this remeasurement to amount to less than 5% (five percent) of the value as recorded by the first measurement. But, where the net errors amount to 5% and over of the said value, then the cost is to be borne by the other party. In any case, if the net value of errors found exceeds Rs. 500/- the expense of re-measurement is to be borne by the other party. If the Contractor's representative fails to attend when required, the Engineer-in-charge shall have power to proceed by himself to take measurement and in that case these measurements shall be accepted by the Contractor as final.
- xi) The contractor shall, once every month, submit to the Engineer-in-charge with a copy to the Civil Manager/Senior Engineer details of his claims for the work done by him up to and including the previous month which are not covered by his Contract Agreement in any of the following respects;
 - a. Deviation from the items and Specifications provided in the contract documents.
 - b. Extra Items/New Items of work
 - c. Quantities in excess of those provided in the contract schedule.
 - d. Items in respect of which rates have not been settled.
 - e. He should, in addition furnish a clear certificate to the effect that the claims submitted by him as aforesaid cover all his claim and that no further claims shall be raised by him in respect of the work done up to and including the period under report.
- xii) Except where any general or detailed description of the work in quantities expressly shows to the contrary, schedule of quantities shall be deemed to have been prepared and measurements shall be taken in accordance with the procedure set forth in the schedule of rates specification notwithstanding any provision in the relevant standard method of measurement or any general or local custom. In the case of items which are not covered by the schedule of rates / specification, measurements shall be taken in accordance with relevant standard method of measurement issued by the Indian Standard Institution or as per standard engineering practice.

113) Valuation of Deviations: Rates for deviated items of work will be fixed as follows:-

- a. For any item of work required to be carried out after the contract has been awarded and which is not covered by Contractor's Schedule but is covered by B.H.E.L Schedule of rates the rate payable for such a fresh item will be derived from B.H.E.L Schedule by the method of proportion as follows:
- b. In the same proportion to rate in B.H.E.L Schedule of Rates as the tendered rate for the nearest analogous item of work in Contractor's schedule bears to rate for the particular analogous item of work in B.H.E.L Schedule of rates.
- c. If a single appropriate analogous item of work is not available in both Schedule (Contractor's and B.H.E.L Schedule) then the method of proportion will be applied

Place
Date

Signature of the Bidder
(NAME & ADDRESS WITH SEAL)



BHARAT HEAVY ELECTRICALS LIMITED

POWER PLANT PIPING UNIT

THIRUMAYAM- 622 507

CONTRACTS DEPARTMENT

Phone : 04333279551

E.mail : ilango@bheltry.co.in Website : www.bhel.com

Tender No:PPPU:WC:14:015

Tender Notice

Dt. 04.10.2014

to the nearest analogous group of items available in both the Schedules referred to i.e. in the same proportion as the total tendered cost of that particular group of items (the sum of the products of the tendered rates and the quantities for which orders are placed bears to the total cost of the same items and quantities at the B.H.E.L Schedule of Rates.

- d. If even an appropriate analogous group of items is not available in Contractor's Schedule and B.H.E.L Schedule, then the methods of proportion will be applied to all those items of the whole work, which are available in both the Schedules and for which orders have been placed on the contractor, i.e., in the same proportion as the total cost of all these items of work (the sum of the products of the tendered rates and the quantities for which orders are placed) bears to the total cost of the same items and qualities at the B.H.E.L Schedule of Rates.
- e. If any work not covered by any of the foregoing is ordered on the Contractor, the basis of payment shall be decided by the Accepting Officer whose decision shall be final and conclusive and binding on the parties.
- f. The selection of analogous items or analogous group of items referred to above shall be done by the Engineer-in-charge. Where the rates for deviated items or new items of work can be derived by the selection of different analogous items or analogous group of items, the lowest of all such derived rates shall be taken as the correct rate.
- g. In the case of the contracts for which the Engineer-in-charge is the Accepting Officer, all disputes regarding the settlement of rates of deviated or new items or work shall be referred to the Deputy Manager/Manager whose decision shall be final and conclusive as the case may be.

114) Reimbursement / Refund on Variation in Price, Materials:

- a. If after submission of the tender and/or during the progress of the works, the price of any material (not being a material supplied from the B.H.E.L store in accordance with the Conditions of the Contract) is increased or decreased by an Act of Legislature (Central or State) and/or any notification there under or on account of new duties or levies such as octroi or on account of increase or decrease in such duties affecting the price of materials required for incorporation in the works and made from materials of which the price has increased or decreased as aforesaid and the Contractor has thereupon to pay in respect of such material or item a price which is higher or lower than the price of that material or item as prevailing immediately before the passing of such Act or levying, increasing/ decreasing of such duty, the B.H.E.L shall incase of increase in price or the duty reimbursed to the contractor and incase of decrease in price, the B.H.E.L shall be entitled to a refund of the reduction price or the reduction in duty. Provided, however no reimbursement or refund shall be made if the increase/decrease is not more than 10% of the said price, and if so, the reimbursement or refund shall be made only on the excess over 10% provided always that any such increase shall not be payable if, in the opinion of the Deputy Manager/Manager (whose decision shall be final and conclusive) the increase is attributable to the delay in the execution of the contract within the control of the contractor or that any such increase has become

Place
Date

Signature of the Bidder
(NAME & ADDRESS WITH SEAL)



BHARAT HEAVY ELECTRICALS LIMITED

POWER PLANT PIPING UNIT

THIRUMAYAM- 622 507

CONTRACTS DEPARTMENT

Phone : 04333279551

E.mail : ilango@bheltry.co.in Website : www.bhel.com

Tender No:PPPU:WC:14:015

Tender Notice

Dt. 04.10.2014

operative after the contracted/or extended date of completion of the work or items of work in question.

- b. The Contractor shall, for the purpose of this condition, keep such books of account and other documents as are necessary to show the amount of any increase claimed or any reduction available and shall allow inspection of the same by any duly authorized representative of the B.H.E.L and further shall at the request of the Engineer-in-charge furnish for verification such other information of the Engineer-in-charge may require.
- c. The Contractor shall within a reasonable time of his becoming, aware of any alteration in the prices of any such materials, give notice thereof in writing to the Engineer-in-charge stating that the rate is submitted in pursuance to this condition together with all information relating thereto which he may be in a position to supply.

115) **Advances on Account:**

- a. No payment shall be made for work estimated to cost less than Rupees **FIVE THOUSAND** till the whole of the work shall have been completed and a certificate of completion given by the Competent Authority.
- b. In the case of work estimated to cost more than Rupees **FIVE THOUSAND** the contractor may at intervals of not less than one month or as otherwise provided for in the Contract Documents, counting from the date on which order to commence work is given by Engineer-in-charge submit claims on B.H.E.L forms for payment of advances on account of work done and of materials delivered in connection with the Contract.
- c. The contractor shall be paid in respect of such claims to the extent approved and passed by the Engineer-in-charge subject a maximum of 90% of the value of the work actually executed to the satisfaction of the Engineer-in-charge. The certificate of the Engineer-in-charge regarding such approval and passing of the sums so payable shall be final and conclusive against the Contractor.
- d. "After the full amount of Security Deposit is made up through the 10% deduction from On account" bills, 100% payment of all subsequent bills may be made to the Contractor.
- e. The Contractor may also be paid during the progress of the work 75% of the value of any materials which are in the opinion of the Engineer-in-charge in accordance with the Contract, and are actually required for incorporation in the work and which have reasonably been brought to the site in connection therewith and are adequately stored and / or protected against damage by weather or other causes, but which have not at the time of payment of the advance been incorporated in the work on furnishing a formal hypothecation deed. Payment of such advances, however, shall be purely at the discretion of the Deputy Manager/Senior Engineer provided always that payments shall not be made under these periodical certificates in respect of perishable materials like lime, cement, timber, sand, kankar, etc., Any sums/due from the Contractor on account of Tools and Plant, Stores or any other items provided by B.H.E.L shall be deducted from the respective

Place
Date

Signature of the Bidder
(NAME & ADDRESS WITH SEAL)



BHARAT HEAVY ELECTRICALS LIMITED

POWER PLANT PIPING UNIT

THIRUMAYAM- 622 507

CONTRACTS DEPARTMENT

Phone : 04333279551

E.mail : ilango@bheltry.co.in Website : www.bhel.com

Tender No:PPPU:WC:14:015

Tender Notice

Dt. 04.10.2014

advances, the Engineer-in-charge shall from time to time certify the sums payable to the contractor after retaining the reserves.

- f. Any certificate relating to work done or materials delivered may be modified or corrected by any subsequent interim certificate or by the final certificate and no certificate of the Engineer-in-charge supporting an advance payment shall itself be conclusive evidence that any work or materials to which it relates are in accordance with the contract. All such intermediate payments shall be regarded as advances against the final payment only and shall not be considered as an admission of the due performance of the contract or any part thereof in any respect or the accruing of any claim whatsoever.
- g. Such intermediate payment shall not conclude, determine or affect in any way the powers of the Engineer-in-charge as to the final settlement and adjustment of the accounts or otherwise, or in any way vary or affect the contract.

116) Final Bill

- a. As soon as possible after the completion of the work to the satisfaction of the Engineer-in-charge, the contractor shall forward a certified final account on BHEL form, in duplicate.
- b. It shall be accompanied by all abstracts, vouchers etc., in support thereof and shall be prepared in the manner prescribed by the Engineer-in-charge.
- c. No claims will be entertained after the receipt of the final bill.
- d. The Contractor shall be entitled to be paid the final sum less the value of payments already made on account subject to certification of the final bill by the Engineer-in-charge. Any sums due from the contractor on account of Tools & Plant, Stores or any other items provided by BHEL not yet recovered from the contractor shall be deducted from the final sum aforesaid.
- e. No charge shall be allowed to the Contractor on account of the preparation of the final bill.

117) **Payment of Bills:** All payment to be made to the Contractor under this contract shall be by NEFT / RTGS only (within a reasonable time after the Certification by the Engineer-in-charge) at the State Bank of India or their subsidiaries located in the station where either the work is executed or service rendered or at their branch nearest to the station where the Officer of the Engineer-in-charge is located.

Place
Date

Signature of the Bidder
(NAME & ADDRESS WITH SEAL)



BHARAT HEAVY ELECTRICALS LIMITED

POWER PLANT PIPING UNIT

THIRUMAYAM- 622 507

CONTRACTS DEPARTMENT

Phone : 04333279551

E.mail : ilango@bheltry.co.in Website : www.bhel.com

Tender No:PPPU:WC:14:015

Tender Notice

Dt. 04.10.2014

COMMERICAL TERMS AND CONDITIONS

1. Sealed Tenders for the work enclosed are hereby invited from contractors meeting the qualifying criteria and experienced in works of similar kind and magnitude.
2. For Limited Tenders, vendors not contacted through post and submitting bids by seeing the CPP portal will be considered only for vendor evaluation. Their price bid will not be considered for ordering.
3. Tenderers should fill in all the required particulars in the blank spaces provided for this purpose in the tender documents and sign each and every page of the tender document including corrigendum & the drawing attached if any, while submitting their bid.

RATE:

1. Item rate only should be quoted in figures as well as in words in the Price Bid.
 2. In case any difference in rates quoted to figures and in words, the rate quoted in words will be taken as the tendered rate.
 3. If there is an error in a total corresponding to the addition or subtraction of subtotals, the subtotals shall prevail and the total shall be corrected; and If there is a discrepancy between words and figures, the amount in words shall prevail, unless the amount expressed in words is related to an arithmetic error, in which case the amount in figures shall prevail subject of (a) and (b) above.
 4. If there is such discrepancy in an offer, the same shall be conveyed to the bidder with target date upto which the bidder has to send his acceptance on the above lines and if the bidder does not agree to the decision of the purchaser, the bid is liable to be ignored.
 5. The rates quoted should be exclusive of service tax and inclusive of any other taxes & duties levied or to be levied both by Central and State Government Authorities. Such levies should be borne by the Contractor.
 6. All entries in the tender documents should be made in one ink. Erasure and over-writing are not permitted. All cancellations and insertions should be duly signed by the Tenderer concerned.
 7. Before tendering, the tenderers are advised to inspect the site of work and its environments and be well acquainted with the actual working and other relevant conditions, position of materials and labour.
 8. The rates quoted in the tender shall remain valid initially for a period of at least "THREE MONTHS" from the date of opening of Price Bid. After successful award of contract, the rates shall be firm throughout the contract period.
 9. Service Tax Payment will be reimbursed as per statutory provisions, subject to production of proof of payment / remittances.
4. Should a tenderer find discrepancies or omissions in the drawings or any of the tender documents should be in doubts as to their meaning; he should at once address the authority inviting the tender for clarifications. Every endeavour is made to avoid any error which can

Place
Date

Signature of the Bidder
(NAME & ADDRESS WITH SEAL)



BHARAT HEAVY ELECTRICALS LIMITED

POWER PLANT PIPING UNIT

THIRUMAYAM- 622 507

CONTRACTS DEPARTMENT

Phone : 04333279551

E.mail : ilango@bheltry.co.in Website : www.bhel.com

Tender No:PPPU:WC:14:015

Tender Notice

Dt. 04.10.2014

materially affect the basis of the tender but the successful tenderer shall be taken upon himself to provide for the risk or any error which may be subsequently discovered and shall make no subsequent claim on account thereof.

5. Conditional and late tenders, tenders containing prima-facie absurd rates and amounts, tenders which are incomplete or otherwise considered defective and tenders not in accordance with the tender conditions herein contained and the tenders not in original are liable to be rejected.
6. Canvassing in any form w.r.t. tenders is strictly prohibited and the tenders submitted by contractors who resort to canvassing are liable for rejection.
7. In the event of tender being submitted by the firm, the tender must be signed separately and legibly by each partner or member of the firm or in their absence, by the person holding the power of attorney on behalf of the firm concerned. In the latter case, a copy of the power of attorney duly attested by a Gazetted Officer must accompany the tender.
8. Every tender must be accompanied by Deposit receipt for the amount mentioned in this tender notice as Earnest Money Deposit in the form of Pay order or Demand Draft duly pledged in favour of BHEL, Thirumayam. EMD shall not carry any interest. One time EMD of ₹ 2 lakhs can also be paid at BHEL, Thirumayam.
9. This Earnest Money Deposit will be refunded to the unsuccessful tenderers within 15 days on finalization of the award of work. In the case of successful tender, the earnest Money Deposit will be retained as part of the Security Deposits for satisfactory completion of the work. One time EMD will not be considered as part of the Security Deposit. If the bidder withdraws his offer after submission of tender or after acceptance of tender or fails to start the work, the EMD shall be forfeited.
10. BHEL reserves the right to
 - i) cancel the tender at any stage.
 - ii) finalize the contract through Reverse Auction / Price Bid Opening.
 - iii) negotiate or refloat the tender opened if L1 price is not the lowest acceptable price to BHEL inter-alia other reasons.
 - iv) decide on equally distributing and awarding the work to two or more vendors if same L1 rate is quoted by many vendors.
10. BHEL reserves the right to go for Reverse Auction (RA) instead of opening the sealed envelope price bid, submitted by the bidder. This will be decided after techno-commercial evaluation. All bidders have to give their acceptance for participation in RA. Non-acceptance to participate in RA may result in non-consideration of their bids, in case BHEL decides to go for RA.
11. In case BHEL decides to go for Reverse Auction, only those bidders who have given their acceptance to participate in RA will be allowed to participate in the Reverse Auction. Those bidders who have given their acceptance to participate in Reverse Auction will have to necessarily submit "online sealed bid" in the Reverse Auction. Non-submission of "online

Place
Date

Signature of the Bidder
(NAME & ADDRESS WITH SEAL)



BHARAT HEAVY ELECTRICALS LIMITED

POWER PLANT PIPING UNIT

THIRUMAYAM- 622 507

CONTRACTS DEPARTMENT

Phone : 04333279551

E.mail : ilango@bheltry.co.in Website : www.bhel.com

Tender No:PPPU:WC:14:015

Tender Notice

Dt. 04.10.2014

sealed bid” by the bidder will be considered as tampering of the tender process and will invite action by BHEL as per extant guidelines in vogue.

12. All payments from BHEL in view of the execution of the contract are liable for IT (TDS), Service Tax, PF & Group Insurance and all other statutory provisions as applicable. Hence, bidders shall confirm that they have suitable mechanism for effective compliance to the same.
13. Service Tax and all other taxes shall be shown extra in the bid. Bharat Heavy Electricals Limited, Thirumayam will not entertain any claim what so ever in this respect after opening the tenders. Also Service Tax Registration form / Self-declaration for non-applicability of Service Tax have to be provided as applicable.

Terms & Conditions of Reverse Auction:

1. Against this enquiry for the subject item/ system with detailed scope of supply as per enquiry specifications, BHEL may resort to “REVERSE AUCTION PROCEDURE” i.e., ON LINE BIDDING (THROUGH A SERVICE PROVIDER). The philosophy followed for reverse auction shall be English Reverse (No ties).
2. For the proposed reverse auction, technically and commercially acceptable bidders only shall be eligible to participate.
3. Those bidders who have given their acceptance for Reverse Auction (quoted against this tender enquiry) will have to necessarily submit „online sealed bid“ in the Reverse Auction. Non-submission of “online sealed bid” by the bidder for any of the eligible items for which techno-commercially qualified, will be considered as tampering of the tender process and will invite action by BHEL as per extant guidelines in vogue.
4. BHEL will engage the services of a service provider who will provide all necessary training and assistance before commencement of on line bidding on internet.
5. In case of reverse auction, BHEL will inform the bidders the details of Service Provider to enable them to contact & get trained.
6. Business rules like event date, time, bid decrement, extension etc. also will be communicated through service provider for compliance.
7. Bidders have to fax the Compliance form (annexure IV) before start of Reverse auction. Without this, the bidder will not be eligible to participate in the event.
8. In line with the NIT terms, BHEL will provide the calculation sheet (e.g., EXCEL sheet) which will help to arrive at “Total Cost to BHEL” like Packing & forwarding charges, Taxes and Duties, Freight charges, Insurance, Service Tax for Services and loading factors (for non-compliance to BHEL standard Commercial terms & conditions) for each of the bidder to enable them to fill-in the price and keep it ready for keying in during the Auction.
9. Reverse auction will be conducted on scheduled date & time.

Place
Date

Signature of the Bidder
(NAME & ADDRESS WITH SEAL)



BHARAT HEAVY ELECTRICALS LIMITED

POWER PLANT PIPING UNIT

THIRUMAYAM- 622 507

CONTRACTS DEPARTMENT

Phone : 04333279551

E.mail : ilango@bheltry.co.in Website : www.bhel.com

Tender No:PPPU:WC:14:015

Tender Notice

Dt. 04.10.2014

10. At the end of Reverse Auction event, the lowest bidder value will be known on auction portal.
11. The lowest bidder has to fax/e-mail the duly signed and filled-in prescribed format for price breakup including that of line items, if required, (Annexure VII) as provided on case-to-case basis to Service provider within two working days of Auction without fail.
12. In case BHEL decides not to go for Reverse Auction procedure for this tender enquiry, the Price bids and price impacts, if any, already submitted and available with BHEL shall be opened as per BHEL's standard practice.
13. Bidders shall be required to read the "Terms and Conditions" section of the auctions site of Service provider, using the Login IDs and passwords given to them by the service provider before reverse auction event. Bidders should acquaint themselves of the "Business Rules of Reverse Auction", which will be communicated before the Reverse Auction.
14. If the Bidder or any of his representatives are found to be involved in Price manipulation/ cartel formation of any kind, directly or indirectly by communicating with other bidders, action as per extant BHEL guidelines, shall be initiated by BHEL and the results of the RA scrapped/ aborted.
15. The Bidder shall not divulge either his Bids or any other exclusive details of BHEL to any other party.
16. In case BHEL decides to go for reverse auction, the H1 bidder (whose quote is highest in online sealed bid) may not be allowed to participate in further RA process.

Place
Date

Signature of the Bidder
(NAME & ADDRESS WITH SEAL)



BHARAT HEAVY ELECTRICALS LIMITED

POWER PLANT PIPING UNIT

THIRUMAYAM- 622 507

CONTRACTS DEPARTMENT

Phone : 04333279551

E.mail : ilango@bheltry.co.in Website : www.bhel.com

Tender No:PPPU:WC:14:015

Tender Notice

Dt. 04.10.2014

CONDITIONS RELATED TO THE WELFARE OF LABOUR

- 1) The successful contractor has to have his own PF, ESI / Group Insurance registration and comply with the relevant Acts.
- 2) The Contractor has to remit PF for his workers for the same amount which he paid as total wages to the employees on monthly basis. He has to remit 13.61% from his side and deduct 12% of Wages from the monthly wages of the employees and a total of 25.61% of monthly wages should be remitted as PF i.r.o. each employee.
- 3) The Contractor has to produce the PF Registration Code for his workers as per the Government rules while submitting the first bill. The first bill will be processed only on production of the above code. For subsequent bills, the PF remittance challan for the engaged labour has to be submitted for bill processing.
- 4) BHEL will not be liable for any medical attention, injury / loss of life of the persons engaged by the contractor during the work inside the factory premises as per the contract. A suitable insurance coverage (ESI / Group Insurance) for the employees shall be arranged by the Contractor at his cost from the first day of operation, towards medical treatment and compensation of any loss as per legal provisions.
- 5) The contractor shall have full control over his employees including the right to appoint, determine service conditions, discharge, dismiss, or otherwise terminate their services at any time. The contractor shall be solely responsible for any claim arising out of employment or termination of employment of his employees and for statutory payments.
- 6) In case, during the contract period if ESI scheme comes into effect, the contractor shall conform to the statutory requirements and any additional cost involved shall be borne by the contractor only.
- 7) The contractor shall employ such personnel who are medically fit and above the age of 18 only. The company has the right to direct the contractor to remove from the premises such of his personnel who may be physically, hygienically, clinically or medically found to be unfit.
- 8) The Minimum Wages as prescribed by the State Government from time to time should be paid to the contract Workers and the Wage and Attendance Registers should be produced to Welfare Section every month.

The minimum wages applicable for the year 2014-15 is given below:

Sl. No.	Category	Minimum Basic Wages per day	Minimum DA per day	Total Minimum Wages per day	Minimum Basic Wages per month	Minimum DA per month	Total Minimum Wages per month
1	Unskilled Worker	Rs.123.00	Rs.161.00	Rs.284.00	Rs.3690.00	Rs.4175.00	Rs.7865.00
2	Semi-Skilled Worker	Rs.133.00	Rs.161.00	Rs.294.00	Rs.3990.00	Rs.4175.00	Rs.8165.00
3	Skilled Worker	Rs.139.00	Rs.161.00	Rs.300.00	Rs.4170.00	Rs.4175.00	Rs.8345.00
4	Supervisor				Rs.3956.00	Rs.4175.00	Rs.8131.00

Apart from the above, an additional monthly payment of ₹ 3200/- for Unskilled, ₹ 3700/- for Semi-Skilled worker and ₹ 4100/- each for Skilled worker is to be ensured.

Place
Date

Signature of the Bidder
(NAME & ADDRESS WITH SEAL)



BHARAT HEAVY ELECTRICALS LIMITED

POWER PLANT PIPING UNIT

THIRUMAYAM- 622 507

CONTRACTS DEPARTMENT

Phone : 04333279551

E.mail : ilango@bheltry.co.in Website : www.bhel.com

Tender No:PPPU:WC:14:015

Tender Notice

Dt. 04.10.2014

- If the contractor employs more than twenty employees, he has to obtain Licence to this effect from the Factory Inspectorate and renew the same periodically.
- The Contract workers should be fully aware of safety measures and observe all safety precautions during work. The contractor should also make his own arrangements to provide requisite safety devices to the workers, based on the nature of work. Any accident/incident occurring to his workers in Company's premises should be reported in writing by the Contractor to Safety, Welfare and Line Executive concerned.
- A list containing the name of working persons' photo, address, age, designation, nature of work is to be furnished immediately on receipt of the contract/work order. This is required for our records and issuance of Identity Card for Gate entry.

The Contractor shall in respect of labour employed by him, comply with the following statutory provisions, rules & in regard to all matters provided therein.

- 1) The Workmen Compensation Act 1923,
 - 2) The Payment of Wages Act 1936 and the related Tamilnadu Rules ,
 - 3) The Industrial Disputes Act 1947,
 - 4) The Factories Act 1948 and the related Tamilnadu Rules ,
 - 5) The Minimum Wages Act 1948 and the related Tamilnadu Rules ,
 - 6) Employee's Provident Funds & Miscellaneous Provisions Act 1952,
 - 7) The Payment of Bonus Act 1965,
 - 8) The Contract labour (Regulation & Abolition) Act 1970 and the related Tamilnadu Rules,
 - 9) The Building and Other Construction Works (RE & CE) Act, 1996 and the related Tamilnadu Rules,
 - 10) Additional Amount of ₹ 3200/-, ₹ 3700/- and ₹ 4100/- to all Unskilled, Semiskilled and Skilled labourers respectively over and above the minimum wage as per BHEL Corporate guidelines.
- 9) The Contractor shall fix wage periods in respect of which wages shall be payable. No wage period shall exceed one month.
- 10) The Contractor shall ensure payment of wages to the contract labour employed by him within three days from the end of wage period in case the wage period is one week or a fortnight and in all other cases before 10th day of the following month.
- 11) All Payment of wages shall be made on working days at the work site and during the working time and on date notified in advance. In case the work is completed before the expiry of the wage period final payment shall be made within 48 hours of the last working day.
- 12) Where the employment of any worker is terminated by or on behalf of the Contractor, the wages earned by him shall be paid before the expiry of the second working day from the day on which his employment is terminated.
- 13) Wages due to every worker shall be paid to him direct or to the person authorized by him in this behalf. All wages shall be paid in current coin or currency in both.
- 14) The Contractor shall ensure the disbursement of wages in the presence of such authorized representative of BHEL Management.

Place
Date

Signature of the Bidder
(NAME & ADDRESS WITH SEAL)



BHARAT HEAVY ELECTRICALS LIMITED

POWER PLANT PIPING UNIT

THIRUMAYAM- 622 507

CONTRACTS DEPARTMENT

Phone : 04333279551

E.mail : ilango@bheltry.co.in Website : www.bhel.com

Tender No:PPPU:WC:14:015

Tender Notice

Dt. 04.10.2014

- 15) The above payment shall be verified by the authorized officer / representative of BHEL with the following certificate of the payment sheet "Certified that the amount shown in Column No..... has been paid to the workmen concerned in my presence onat....."
- 16) A certificate of payment shall be furnished in duplicate by the Contractor to the Engineer in charge each month in Form 'A'.
- 17) A notice showing the wage period and the place and time of disbursement of wages shall be displayed at the place of work and a copy to be sent to the Welfare Department by the Contractor under acknowledgement.
- 18) Notices showing the rate of wages, weekly rest days, hours of work, wage period, date of payment of wages, names and addresses of the Inspector having jurisdiction, the date of unpaid wages shall be displayed in Tamil and English in conspicuous places at the establishment and at work site by the Contractor. The Contractor shall inform the BHEL Management every month the details of contract labour engaged for contract in this following form :
 - a. Serial Number
 - b. Location
 - c. Period of work
 - d. No. of contract labour engaged during the month
 - e. No. of days worked
 - f. No. of men worked
 - g. Wages paid to workers

The above statement shall be furnished to BHEL Management at the end of every month.

REGISTERS AND RECORDS AND COLLECTION OF STATISTICS

- 1) The following documents / formats under Contract Labour (Regulation & Abolition) Act 1970 and Tamil Nadu Rules thereunder shall be maintained by each contractor.
 - a) Register of persons employed by the Contractor
 - b) Employment Card
 - c) Service Certificate
 - d) Muster Roll, Wage Register, Deduction Register, Wage slip, Overtime Register, Register of Fines, Register of Advances etc.
- 2) The Contractor shall display the abstract of the Contract Labour (Regulation & Abolition) Act and the Rules thereunder both in English and Tamil.
- 3) Half yearly Return shall be sent by the Contractor in duplicate to the Licensing Officer.
- 4) The Contractor shall submit the returns required under the Contract Labour (Regulation & Abolition) Act 1970 periodically to BHEL Management.
- 5) The Contractor shall without fail give upto date information in writing of the attendance of the workers employed by him.
- 6) The Contractor shall ensure that his workers keep and produce their Employment Card when coming to duty and take them back when leaving duty.
- 7) All the above registers and records shall be preserved in original for a period of three years. All the registers, records and notice maintained under the Act and rules shall be produced on demand by Inspector or any authority under the Act.

Place
Date

Signature of the Bidder
(NAME & ADDRESS WITH SEAL)



BHARAT HEAVY ELECTRICALS LIMITED

POWER PLANT PIPING UNIT

THIRUMAYAM- 622 507

CONTRACTS DEPARTMENT

Phone : 04333279551

E.mail : ilango@bheltry.co.in Website : www.bhel.com

Tender No:PPPU:WC:14:015

Tender Notice

Dt. 04.10.2014

WORKING HOURS AND WORKING CONDITIONS

- 1) No worker shall be required or allowed to work on Sunday unless he has or will have a holiday on anyone of the three days before or after the said day.
- 2) The Contractor shall inform BHEL Management in the prescribed form details of the contract workers scheduled to work on Sunday, the day of rest and also indicate the substituted holiday in lieu thereof. This shall be intimated two days in advance before his workmen are booked for work on Sunday.
- 3) The contract labour working for more than nine hours in any day or for more than 48 hours in any week shall be paid wages at the rate of twice the ordinary rate of wages in accordance with the provisions of Sections 59 of the Factories Act 1948.
- 4) The Contractor shall provide all safety devices and personal protective equipment to his workmen at his own cost and shall ensure that his workmen wear / use such devices or equipment provided to them while doing the work and there should not be any relaxation on this.
- 5) The Contractor shall give four paid National Holidays to his workers, viz., 26th January, 1st May, 15th August and 2nd October.
- 6) The Contractor shall ensure that his workmen vacate the premises after the shift is over.
- 7) The Contractor shall give leave with wages to his workmen who have worked for a period of 240 days or more in the Factory premises during a calendar year. This leave shall be allowed during the subsequent calendar year at the rate of one day for every 20 days of work performed by the worker during the previous calendar year. The worker whose services commences on a day other than the first of January shall be entitled to leave with wages at the above rate (One day for every 20 days of work) only if he had worked for a minimum of 2/3 of the total number of days in the remainder of the calendar year. This leave will be admissible only during the subsequent calendar year.
- 8) No woman worker shall be required or allowed to work in the Factory except between the hours of 6.00 A.M. and 7.00 P.M.
- 9) The Contractor shall comply with the provisions relating to Welfare and Health facilities as provided in the Contract Labour (Regulation and Abolition) Act 1970 read with the Tamil Nadu Contract Labour Rules 1975.

Place
Date

Signature of the Bidder
(NAME & ADDRESS WITH SEAL)



BHARAT HEAVY ELECTRICALS LIMITED

POWER PLANT PIPING UNIT

THIRUMAYAM- 622 507

CONTRACTS DEPARTMENT

Phone : 04333279551

E.mail : ilango@bheltry.co.in Website : www.bhel.com

Tender No:PPPU:WC:14:015

Tender Notice

Dt. 04.10.2014

GENERAL TERMS & CONDITIONS OF CONTRACT

DEFINITION: - In these General Conditions of Contract, the following terms shall have the meaning hereby assigned to them, except where the context otherwise requires:-

The "**Contract**" means, the documents forming the tender and acceptance thereof, together with all the documents referred to therein including general and special conditions to contract. All these documents as applicable taken together shall be deemed to form one contract and shall be complementary to one another.

The "**work**" means, the work described in the tender documents in individual work-orders as may be issued from time to time to the contractor by the Officer-Incharge within the power conferred upon him including all notified or additional items of works and obligations to be carried out as required for the performance of contract.

The "**contractor**" means, the individual Firm or Company whether incorporated or not, undertaking the work and shall include the legal personal representatives of such individuals or the persons composing the firm or Company or the successors of the firm or company and the permitted assigns of such individual or firm or Company.

"The **Officer-In charge**" means, the Officer deputed by the AGM/PPPU-THIRUMAYAM, to supervise the work or part of the work.

"**Approved**" and "**Directed**" means, the approval or direction of AGM/PPPU-THIRUMAYAM, or person deputed by him for the particular purposes.

BHARAT HEAVY ELECTRICALS LIMITED" (herein after referred to as BHEL) shall mean the Board of Directors, Chairman, Executive Director, General Manager or other Administrative Officer of the said Company including Executive/CONTRACTS/PPPU authorised to invite tenders and enter into contract for works on behalf of the Company.

The "**Contract sum**" means, the sum accepted or the sum calculated in accordance with the prices accepted in tender and / or the contract rates as payable to the contractor for the execution of the work during the currency of the contract.

A "**week**" means, Seven Days, without regard to the number of hours worked or not worked in any day in that week.

A "**day**" means, the day of 24 hours (TWENTY FOUR) irrespective of the number of hours worked or not worked in that day.

A "**working day**" means, any day other than that prescribed by the NEGOTIABLE INSTRUMENTS ACT as being a Holiday, and consists of the number of hours of labour as commonly recognised by good employers in the trade in the district where the work is carried out or as laid down in the BHEL regulations.

HEADING TO THE CONTRACT CONDITIONS: - The heading to these conditions shall not affect the interpretations thereof.

WORK TO BE CARRIED OUT:- The Contract shall, include all labour, materials, tools, plant, equipment and transport which may be required for the execution of the work. The Contractor will be deemed to have satisfied himself as to the nature of the site, local facilities of access and all matters affecting the execution of the work. No extra charges consequent on any misunderstanding in these respects or otherwise will be allowed.

Place
Date

Signature of the Bidder
(NAME & ADDRESS WITH SEAL)



BHARAT HEAVY ELECTRICALS LIMITED

POWER PLANT PIPING UNIT

THIRUMAYAM- 622 507

CONTRACTS DEPARTMENT

Phone : 04333279551

E.mail : ilango@bheltry.co.in Website : www.bhel.com

Tender No:PPPU:WC:14:015

Tender Notice

Dt. 04.10.2014

DEVIATIONS:- The contractor shall not carry out any work not covered by schedule except in pursuance of the written instructions of AGM/PPPU-THIRUMAYAM,. No such work shall be valid unless the same has been specifically confirmed and accepted by BHEL in writing and incorporated in the Contract.

ASSIGNMENT OF TRANSFER OF CONTRACT:- The Contractor shall not without the prior written approval of the BHEL, assign or transfer the contract or any part thereof, or any share, or interest thereon to any other persons. No sum of money which may become payable under the contract shall be payable to any person, other than the contractor unless the prior written approval of the BHEL to the assignment or transfer of such money is given.

SUB-CONTRACT:- The Contractor shall not sub-let any portion of the contract without the prior written approval of the BHEL.

COMPLIANCE TO REGULATIONS AND BY-LAWS: - The Contractor shall confirm to the provisions of any statute relating to the work and regulations and Bye-Laws of any local authority. The Contractor shall be bound to give all notices required by statute regulations or By-Laws as aforesaid and to pay all fees and taxes payable to any authority in respect thereof.

SECURITY DEPOSIT:-

Security Deposit should be paid by the contractor. Security Deposit shall be collected from the successful tenderer as shown below:

Contract Value Up to ₹.10 Lakhs	10% of the contract value
For Contract Valued above ₹.10.00 Lakh upto 50.00 Lakhs	1 lakh plus 7.5% on the balance of the Contract value.
For Contracts valued above ₹.50.00 Lakhs	₹.4 lakhs + Plus 5% on the balance of the contract value.

The Security Deposit shall be deposited before start of the Work. Failure to remit the Security Deposit shall be treated as failure to discharge the duties under the contract and shall result in cancellation of the contract and the bidder shall be liable to compensate BHEL for any loss. EMD in such cases shall be forfeited.

The Security Deposit may be furnished in any one of the following forms:

- Cash (as permissible under the Income Tax Act) – at present not applicable to BHEL- Thirumayam.
- Pay Order, Demand Draft in favour of BHEL
- Local cheques of scheduled banks, subject to realization.
- Securities available from Post Offices such as National Savings Certificates, Kisan Vikas Patras etc. (Certificates should be held in the name of Contractor furnishing the security and duly pledged in favour of BHEL and discharged on the back).

Place
Date

Signature of the Bidder
(NAME & ADDRESS WITH SEAL)



BHARAT HEAVY ELECTRICALS LIMITED

POWER PLANT PIPING UNIT

THIRUMAYAM- 622 507

CONTRACTS DEPARTMENT

Phone : 04333279551

E.mail : ilango@bheltry.co.in Website : www.bhel.com

Tender No:PPPU:WC:14:015

Tender Notice

Dt. 04.10.2014

- v) Bank Guarantee from Scheduled Banks/ Public Financial Institutions as defined in the Companies Act. The Bank Guarantee format should have the approval of BHEL and with minimum validity covering the contract period & maintenance period if any.
- vi) In order to ensure the genuineness of BG's, the BG's are to be sent directly by the concerned bank through registered post to The Senior Manager, CONTRACTS/PPPU, PPPU, BHEL Thirumayam.
- vii) Fixed Deposit Receipt issued by Scheduled Banks/ Public Financial Institutions as defined in the Companies Act. The FDR should be in the name of the contractor, A/C BHEL, duly discharged on the back and with minimum validity covering the contract period & maintenance period if any.
- viii) Security deposit can also be recovered at the rate of 10% from the running bills. However in such cases at least 50% of the Security Deposit should be collected (any of the above form) and the balance 50% may be recovered from the running bills.

The security deposit shall not carry any interest.

The Earnest Money paid at the time of tender (except one time EMD) will be adjusted as part of the Security Deposit and the balance amount will be collected from the contractor as mentioned above.

Security Deposit shall not be refunded except in accordance with the terms of the Contract or Agreement. No interest shall be allowed on Security Deposits. BHEL shall not be responsible for any loss of securities, due to liquidation for any other reasons, what-so-ever or any depreciation in the value of the securities while in their charge or for any loss of interest there on.

All compensation or other sums of money payable by the Contractor to BHEL under the terms of this contract or under any other contract with BHEL may be deducted from the Security Deposit or realised by the sale of the securities or from the interest arising there from or from any sums which may be due or may become due to the contractor by BHEL and in the event of this Security Deposit being deducted by reason of such deductions or sale, as aforesaid, the Contractor shall within 7 days thereafter, make good in cash or in securities endorsed as aforesaid, any sum by which the Security Deposit has been reduced.

REFUND OF SECURITY DEPOSIT:- Security Deposit will be refunded on completion of the work and after the expiry of the maintenance period, if any, provided always that the Contractor shall first have been paid the last and final bill and have rendered a "NO DEMAND CERTIFICATE". In case no maintenance period is applicable, then 100% of security Deposit will be refunded after providing "No Demand" certificate by the contractor as per the "Refund of Security Deposit" format.

ORDERS UNDER THE CONTRACT:- All orders, notices etc. to be given under the contract shall be in writing, type-script or printed and if sent by registered post to the address given in the tender of the Contract, shall be deemed to have been served on the date, when in the ordinary course they would have been delivered to him. The Contractor shall carry out without delay all orders given to him.

Place
Date

Signature of the Bidder
(NAME & ADDRESS WITH SEAL)



BHARAT HEAVY ELECTRICALS LIMITED

POWER PLANT PIPING UNIT

THIRUMAYAM- 622 507

CONTRACTS DEPARTMENT

Phone : 04333279551

E.mail : ilango@bheltry.co.in Website : www.bhel.com

Tender No:PPPU:WC:14:015

Tender Notice

Dt. 04.10.2014

CONTRACTOR'S SUPERVISION:- The Contractor shall either himself supervise the execution of the contract or shall appoint a competent agent acceptable to the AGM/PPPU-THIRUMAYAM, to act in his stead.

Orders given to the Contractor's agent shall be considered to have the same force as if they have been given to the Contractor himself.

The Contractor or his accredited agent shall attend when required without making any claim for doing so, either the office of the Executive/CONTRACTS/PPPU or the OFFICER-INCHARGE, to receive instructions.

BHEL-PPPU, THIRUMAYAM shall have full powers and without assigning any reason, require the Contractor to immediately cease to employ in connection with this contract, any agent, servant or employee where continued employment is, in his opinion undesirable. The Contractor shall not be allowed any compensation on this account.

LABOUR:- The Contractor shall remain liable for the payment of all wages or other moneys to his work-people or employees under the payment of Wages Act 1936, Employees Liability Act. 1938, Workmen's Compensation Act 1923 or any other Act or enactment, relating thereto and rules framed, there under from time to time.

PRECAUTIONS AGAINST RISK: - The Contractor shall be responsible for providing at his own expense for all precautions to prevent loss or damage from any and all risks and to minimize the amount of any such loss or damage and for the necessary steps to be taken for the said purpose.

DAMAGE & LOSS TO PRIVATE PROPERTY & INJURY TO WORKMEN :- The Contractor shall at his own expense reinstate and make good to the satisfaction of the AGM/PPPU-THIRUMAYAM, and pay compensation for any injury, loss or damage occurred to any property or rights whatever including property and rights of BHEL (or agents) servants or employee of BHEL, the injury loss or damage arising out of or in any way in connection with the execution or purported execution of the contract and further the contractor shall indemnify, the BHEL against all claims enforceable against BHEL (or any agent, servant or employee of BHEL) or which would be so enforceable against BHEL where BHEL is a private person, in respect of any such injury (including injury resulting in death) loss or damage to any person whomsoever or property including all claims which may arise under the Workmen's Compensation Act or otherwise.

LAWS GOVERNING THE CONTRACT:- The contract shall be governed by the Indian Laws for time being in force.

(i) Should a tenderer or a contractor has a dependent/relative or in the case of a partnership firm, any of its partners or dependents of partners employed in BHEL, the authority inviting tenders should be informed of this fact at the time of submission of the tender failing which tender may be disqualified or if such fact subsequently come to light, the contract may be cancelled.

(ii) No BHEL employee and their dependents are eligible to submit their offer against this tender.

CANCELLATION OF CONTRACT FOR CORRUPT ACTS:- BHEL, whose decision shall be final and conclusive, shall without prejudice to any other right or remedy which shall have accrued shall accrue thereafter to BHEL cancel the contract in any of the following cases and the Contractor shall

Place
Date

Signature of the Bidder
(NAME & ADDRESS WITH SEAL)



BHARAT HEAVY ELECTRICALS LIMITED

POWER PLANT PIPING UNIT

THIRUMAYAM- 622 507

CONTRACTS DEPARTMENT

Phone : 04333279551

E.mail : ilango@bheltry.co.in Website : www.bhel.com

Tender No:PPPU:WC:14:015

Tender Notice

Dt. 04.10.2014

be liable to make payment to BHEL for any loss or damage resulting from any such cancellation to the same extent as provided in the case of cancellation for default.

If the Contractor shall:-

- Offer or give or agree to give to any person in BHEL service any gift or consideration of any kind, as an inducement or reward for doing or for bearing to do or for having done or for borne to do any act, in relation to the obtaining or execution of this or any other contract for BHEL service,

OR

- enter in to a contract with BHEL in connection with which commission has been paid or agreed to be paid by him or with his knowledge, unless the particulars of any such commission and the terms of payment thereof have previously been disclosed in writing to BHEL.

OR

- obtain a contract with BHEL as a result of ring tendering or by non-bonafide methods of competitive tendering, without first disclosing the fact in writing to BHEL.

CANCELLATION OF CONTRACT FOR INSOLVENCY ASSIGNMENT OF TRANSFER OR SUB-LETTING OF CONTRACT :-

BHEL, without prejudice to any other right or remedy which shall have accrued or shall accrue thereafter to BHEL shall cancel the contract in any of the following cases:

If the Contractor,

- being an individual or if a firm any partner thereof shall at any time be adjudged bankrupt or have a receiving order for administration of his estate, made against him or shall take any proceedings for liquidation or composition under any bankruptcy Act or assignment of his effects of composition or arrangement for the benefit of his creditors or purport to do so, or if any application made under any Bankruptcy Act for the time being in force for the sequestration of his estate or if a trust deed be granted by him on behalf of his creditors

OR

- being a Company, shall pass a resolution or the Court shall make an order for the liquidation of its affairs, or a receiver or Manager on-behalf of the debenture holders shall be appointed or circumstances shall arise which entitle the Court or debenture holders to appoint a receiver or Manager,

OR

- Assigns, Transfers, Sub-lets or attempts to assign, transfer or sub-let any portion of the work without the prior written approval of the BHEL.

OR

- Fails to carry out the work and unauthorized absence for more than 3 days.

Place
Date

Signature of the Bidder
(NAME & ADDRESS WITH SEAL)



BHARAT HEAVY ELECTRICALS LIMITED

POWER PLANT PIPING UNIT

THIRUMAYAM- 622 507

CONTRACTS DEPARTMENT

Phone : 04333279551

E.mail : ilango@bheltry.co.in Website : www.bhel.com

Tender No:PPPU:WC:14:015

Tender Notice

Dt. 04.10.2014

Whenever BHEL exercise the authority to cancel the contract under these conditions, BHEL may have the work done by any means at the Contractor's risks and expenses provided always that in the event of the cost of the work so done (as certified by EXECUTIVE/CONTRACTS/PPPU which is final and conclusive) being less than the contract cost, the advantage shall accrue to the BHEL and if the cost exceeds the money due to Contractor under the contract, the Contractor shall either pay the excess amount ordered by AGM/PPPU-THIRUMAYAM, or the same shall be recovered from the Contractor by other means.

In case the BHEL carries-out the work under the provisions of this condition the cost to be taken into account in determining the excess cost to be charged to the Contractor under this condition shall consist of the cost of the materials, hire charges of tools and plants and/or labour provided by the BHEL with an addition of such percentage to cover superintendence and establishment charges as may be decided by the AGM/PPPU-THIRUMAYAM, whose decision shall be final and conclusive.

CANCELLATION OF CONTRACT IN PART OR FULL FOR CONTRACATOR'S DEFAULT:

If the Contractor:

- makes default in carrying out the work as directed and continues in that state after a reasonable notice from AGM/PPPU-THIRUMAYAM, or his authorised representative ;
- fails to comply with any of the Terms and Conditions of the contract or after reasonable notice in writing with orders properly issued there under ;
- BHEL, may without prejudice to any other right or remedy which shall have accrued or shall accrue thereafter to BHEL CANCEL the contract as whole or in part thereof or only such work order or items of work in default from the contract. Whenever BHEL exercise the authority to cancel the contract as whole or part under this condition BHEL may complete the work at the contractor's risk and cost (as certified by AGM/PPPU-THIRUMAYAM, which is final and conclusive) being less than the contract cost, the advantage shall accrue to the BHEL. If the cost exceeds the moneys due to the Contractor under this contract the Contractor shall either pay the excess amount ordered by EXECUTIVE/CONTRACTS/PPPU or the same shall be recovered from the Contractor by other means. In case the BHEL carries out the work or any part thereof under the provisions of the conditions the cost to be taken into account in determining the excess cost to be charged to the Contractor under this condition shall consist of the cost of the materials, hire charges of tools and plant and/or labour provided by the BHEL with an addition of such percentage to cover the superintendence and establishment charges as may be decided by the AGM/PPPU-THIRUMAYAM, whose decision shall be final and conclusive.

TERMINATION OF CONTRACT ON DEATH OF CONTRACTOR. :-

Without prejudice to any of the rights or remedies under this contract, if the Contractor dies, or if the firm is dissolved or the company is liquidated, BHEL shall have the option of terminating the contract without compensation to the Contractor.

Place
Date

Signature of the Bidder
(NAME & ADDRESS WITH SEAL)



BHARAT HEAVY ELECTRICALS LIMITED

POWER PLANT PIPING UNIT

THIRUMAYAM- 622 507

CONTRACTS DEPARTMENT

Phone : 04333279551

E.mail : ilango@bheltry.co.in Website : www.bhel.com

Tender No:PPPU:WC:14:015

Tender Notice

Dt. 04.10.2014

SPECIAL POWER TO TERMINATION:- If at any time after the award of contract, BHEL shall for any reason whatsoever not require whole or any part of the work to be carried out the AGM/PPPU-THIRUMAYAM, shall give notice in writing of the fact to the Contractor who shall have no claim to any payment of compensation or otherwise howsoever on account of any profit or advantage which he might have derived from the execution of the work in full but which he did not derive in consequence of the fore-closing of the work.

SUBMISSION OF BILLS BY CONTRACTOR:- The Contractor at the end of each month shall submit a bill in triplicate detailing the various items of work done during the month supported by the requisitions issued from time to time. The Contractor shall, once in every month, submit to the AGM/PPPU-THIRUMAYAM, separately details of his claims for the work done by him up to and including the previous month which are not covered by his contract agreement in any of the following respects:

- Deviation from the items provided in the contract documents.
- Extra items / new items of work.
- Items in-respect of which rates have not been settled. He should in addition furnish a clear certificate to the effect that the claims submitted by him as aforesaid cover all his claims and that no further claims shall be raised by him in respect of the work done up to and including the period under report.

PAYMENT OF BILLS:- All payments to be made to the Contractor, under this contract shall be through Electronic Fund Transfer within a reasonable time after the certification of bills by the competent authority.

RECOVERY FROM CONTRACTOR:- Whenever under the contract, any sum of money, shall be recoverable from or payable by the Contractors, the same may be deducted from or any sum then due or which at any time thereafter may become due to Contractor under the contract or under any other contract with BHEL or from his Security Deposit or he shall pay the claim on demand.

POST TECHNICAL AUDIT OF WORK AND BILLS:- BHEL reserves the right to carry out the post-payment Audit and technical examination of the work and final bill including all supporting vouchers, abstracts etc., and enforce recovery of any sum becoming due as a result thereof in the manner provided in the presiding sub-paragraphs. However no such recovery shall be enforced after three years of passing the final bill.

FORCE MAJEURE CLAUSE:- If, at any time during the continuance of this Contract the performance in whole or in part by either party of any obligations under this Contract shall be prevented or delayed by reason of any War, Hostile acts of the public enemy Civil Commotion, Epidemics, or Acts of God (Floods, Storm/Cyclone, Hurricane, Earth Quake etc.) then provided notice of happening of any such event is given by either party to other within 7 days from the date of occurrence therefore neither party shall by reason of such event be entitled to terminate this Contract nor shall either party have any claim for damages against the other in respect of such non-performance and delay in

Place
Date

Signature of the Bidder
(NAME & ADDRESS WITH SEAL)



BHARAT HEAVY ELECTRICALS LIMITED

POWER PLANT PIPING UNIT

THIRUMAYAM- 622 507

CONTRACTS DEPARTMENT

Phone : 04333279551

E.mail : ilango@bheltry.co.in Website : www.bhel.com

Tender No:PPPU:WC:14:015

Tender Notice

Dt. 04.10.2014

performance under the contract shall be resumed as soon as practicable after such event has come to an end or ceased to exist. If the performance in whole or part of any obligation under this Contract is prevented or delayed by reason of any such event, claims for extension of time shall be granted for periods considered reasonable by the Executive/Contracts/PPPU subject to prompt notification by the contractor.

ARBITRATION: - All disputes between the parties to the contract, arising out-of or relating to the contract, other than those for which the decision of the AGM/PPPU-THIRUMAYAM, or Accepting Officer or any other person is by the contract expressed to be final and conclusive shall after written notice by either party to the contract to the other party be referred to the sole Arbitration of Executive Director or other Officers of BHEL appointed as Arbitrator, by the Executive Director of BHEL in his sole discretion.

Unless the parties otherwise agree, such reference shall not take place until after the completion, alleged completion or abandonment of the work of the determination of the contract.

The venue of Arbitration shall be such a place or places as may be fixed by the Arbitrator in his sole discretion. The award of the Arbitrator shall be final, conclusive and binding on both parties to the contract.

SIGNING OF CONTRACT:- Each contract document shall be signed by the Contractor with his usual signature. Contract by partnership of Hindu Joint Family firm, may be signed in the FIRM'S name by one of the Partners or the Karta or Manager as the case may be or by any other duly authorised representative followed by the name and designation of the persons so signing. Contracts by a Company shall be signed with the name of the Company by a person authorised in this behalf and a power of attorney or other satisfactory proof showing that the persons signing the Contract documents on behalf of the Company is duly authorised to do so, shall accompany the contract.

STATUTORY REQUIREMENTS:

- All statutory requirements under Minimum Wages Act,1948, Factories Act 1948, Workmen Compensation Act 1923,Employees Provident Fund and Miscellaneous Provisions Act, 1952,Payment of Gratuity Act 1972, Employee State Insurance Act 1948, Contract Labour (R&A) Act 1970, Payment of Bonus Act 1965, Income Tax Act, Service Tax Act and all other applicable Acts shall be complied with by the Contractor.
- Contractor shall comply with all statutory requirements, rules, regulations, notifications in relation to employment of his employees issued from time to time by the concerned authorities.
- Contractor shall indemnify BHEL against all claims and losses under various Labour Laws, statutes or any civil or criminal law in connection with employees deployed by him.
- Contractor wherever applicable shall maintain proper records prescribed by the concerned statutory authorities and provide a copy of the same to BHEL.
- Contractor shall furnish proper returns to the concerned statutory authorities and provide a copy of the same to BHEL.

Place
Date

Signature of the Bidder
(NAME & ADDRESS WITH SEAL)



BHARAT HEAVY ELECTRICALS LIMITED

POWER PLANT PIPING UNIT

THIRUMAYAM- 622 507

CONTRACTS DEPARTMENT

Phone : 04333279551

E.mail : ilango@bheltry.co.in Website : www.bhel.com

Tender No:PPPU:WC:14:015

Tender Notice

Dt. 04.10.2014

REGISTERS & RECORDS:- The Contractor shall maintain all registers and records in the proper manner and as required by the regulations of the various authorities concerned and indemnify the Employer from the consequences due to any inaccurate or faulty documentation on the part of the Contractor.

MOTOR VEHICLE ACT:- The transporter shall carry the weight of the consignment to the rated capacity of the vehicle only and Honour the Supreme Court Judgment by not carrying Over Weight and comply with the relevant Motor Vehicle Act and other statutory requirement.

REMOTE TRANSACTIONS:- The Contractor shall agree to and comply with all such terms and conditions as BHEL may prescribe from time to time and shall confirm that all transactions effected by or through facilities for conducting remote transactions including the Internet, World Wide Web, electronic data interchange, call centers, teleservice operations (whether voice, video, data or combination thereof) or by means of electronic, computer, automated machines network or through other means of telecommunication established by BHEL shall constitute legally binding and valid transactions when done.

CHANGE IN CONSTITUTION OF FIRM: - Changes in constitution of firm whenever it is made after submission of application or during currency of the contract, the existing firm has to duly inform the proposed changes to contracting department of BHEL at the appropriate time before the changes in the constitution are made. In case the absence of any such information BHEL is not responsible for the consequences arising out of the absence or suppression of information and the issue / dispute arising out of these changes and the firm is responsible for settling the issue or dispute among themselves (Partners etc) or with the bankers or with any third party. Under the above circumstances when dispute arises and the firm does not inform the change in the constitution of the firm BHEL may reserve its rights for suspending or terminating the contract.

LIEN OF CONSIGNMENTS:- The Contractor shall have no 'lien' of any kind over the consignments entrusted for transportation. Any dispute with the Contractor and the consignees shall be settled on negotiations but under no circumstances, delivery of the materials shall be withheld by the Contractor. Contractor shall watch and safeguard Employer's interests during the performance of the work. The Contractor shall carefully check each consignment with the relevant despatch documents to ensure correctness of each despatch and each delivery.

Place
Date

Signature of the Bidder
(NAME & ADDRESS WITH SEAL)



BHARAT HEAVY ELECTRICALS LIMITED

POWER PLANT PIPING UNIT

THIRUMAYAM- 622 507

CONTRACTS DEPARTMENT

Phone : 04333279551

E.mail : ilango@bheltry.co.in Website : www.bhel.com

Tender No:PPPU:WC:14:015

Tender Notice

Dt. 04.10.2014

MSE VENDORS:- The MSE status is based on acknowledgement of Entrepreneur Memorandum Part II (hereinafter referred as EM II Certificate), the validity of such EM II certificate will be **deemed as 2 years** from the date of acknowledgement of the EM II certificate, unless it is accompanied by a CA certificate, certifying that investment in plant & machinery of the supplier is within the permissible limits as per the MSME Act for relevant status (Micro or Small).

MSE suppliers can avail the intended benefits only if they submit along with their bid, attested copies of either EM II certificate having deemed validity (Two years from the date of issue of acknowledgement in EM-II) or valid NSIC certificate or EM II certificate along with CA certificate (Format as provided below) applicable for the year, certifying quantum of investment in plant and machinery within permissible limit as per the act for relevant status (Micro or small) where the deemed validity of EM II is over. Date to be reckoned for determining the deemed validity will be the last date of technical bid submission. Non submission of such documents will lead to consideration of their bids at par with other bidders and MSE status of such suppliers shall be shifted to Non MSE supplier till the supplier submits these documents.

Certificate by Chartered Accountant on letter head

This is to certify that M/s. _____ (hereinafter referred to as 'company') having its registered office at _____ is registered under MSMED Act 2006, (Entrepreneur Memorandum No (Part II)) _____ dtd. _____, Category: _____ (Micro/Small). (Copy enclosed).

Further verified from the Books of Accounts that the investment of the company as on date _____ as per MSMED Act 2006 is as follows:

1. For Manufacturing Enterprises: Investment in plant and machinery (i.e. original cost excluding land and building and the items specified by the Ministry of Small Scale Industries vide its notification No. S.O.1722(E) dated October 5, 2006):
₹ _____ Lacs
2. For Service Enterprises: Investment in equipment (original cost excluding land and building and furniture, fittings and other items not directly related to the service rendered or as may be notified under the MSMED Act 2006):

The above investment of ₹ _____ Lacs is within permissible limit of ₹ _____ Lacs for _____ Micro / Small (Strike off which is not applicable) Category under MSMED Act 2006.

Date:

(Signature)

Name:

Membership number:

Seal of Chartered Accountant

Place

Date

Signature of the Bidder
(NAME & ADDRESS WITH SEAL)



BHARAT HEAVY ELECTRICALS LIMITED

POWER PLANT PIPING UNIT

THIRUMAYAM- 622 507

CONTRACTS DEPARTMENT

Phone : 04333279551

E.mail : ilango@bheltry.co.in Website : www.bhel.com

Tender No:PPPU:WC:14:015

Tender Notice

Dt. 04.10.2014

TERMS & CONDITIONS RELATED TO SAFETY

At the time of Ordering, Health and Safety records along with Certificate of Registration with appropriate authorities under "The Building and Other Construction Workers (RE&CS) Act, 1996" to be submitted to BHEL.

SAFETY CONDITIONS: Tamil Nadu Factories Rules, 1950

Rule 61F: Methods of Work: No process or work shall be carried on in any factory in such a manner as to cause risk of bodily injury.

Rule 61G: Stacking and storing of materials etc.: No materials or Equipment shall be stacked or stored in such a manner as to cause risk of bodily injury.

Rule 61-N and Rule 61- O: Workers to be provided with Personal Protective equipment suitable for the hazards and should be of good quality / have certification by Indian Standard Institute.

Rule 96: Notification of Accidents: Shall be complied with as required in the Factories Act (Section 88 and Section 88A) and Tamil Nadu Factories Rules.

The following safety measures should be strictly adhered to during execution of works at sites.

1. Providing the working platform with toe board and handrail for continuous working at heights.
2. Providing safety belt and life line at all times for men working at heights.
3. Providing dust or fume respirator in places where dust and fume concentration exists.
4. Providing goggles and welding screens.
5. Providing acid and alkali proof rubber gloves for handling acid and alkali and chemical which are corrosive.
6. Providing rubber gloves for working on electrical works.
7. Ensuring proper lashing of the components while being transported in vehicles.
8. The vehicles must have side supports or have body to support the materials conveyed.
9. The materials should not be allowed to extend or overflow the sides of the vehicles.
10. Materials should not be allowed to overhang from the rear edge of the body of the vehicle.
11. Driver of the vehicle must possess license.
12. Vehicle must not be overloaded prescribed limits.
13. Red flags and lights for parts projecting from the body of vehicle must be provided.
14. The speed restrictions within the factory premises must be strictly adhered to.
15. The gas cylinders must be always handled on trolleys or kept tied down not in use. They should never be rolled as Roller for conveying.

Place
Date

Signature of the Bidder
(NAME & ADDRESS WITH SEAL)



BHARAT HEAVY ELECTRICALS LIMITED

POWER PLANT PIPING UNIT

THIRUMAYAM- 622 507

CONTRACTS DEPARTMENT

Phone : 04333279551

E.mail : ilango@bheltry.co.in Website : www.bhel.com

Tender No:PPPU:WC:14:015

Tender Notice

Dt. 04.10.2014

16. Cylinders should not be used without regulators.
17. All excavations must be barricaded and red lamps must be provided.
18. All electrical connections must be properly earthed.
19. No work should be taken up for execution inside shop floor, without obtaining necessary work permit.
20. Providing helmet, safety belt, etc., for high level work and sufficient number of Industrial Safety nets at appropriate level to safeguard the persons working at high level particularly in trusses, girders, roofing etc., of industrial and high roof buildings.
21. The contractor should maintain a register regarding the driver license particulars.
22. All personal protective equipment conform with standard specification as per the details given in the code of conduct.

Contractor including their sub contractors, agents and labour engaged on the work are required to scrupulously adhere to the safety regulations, safety precautions and measures. Any violation thereof will invite punitive action being taken against them. Also contractors with frequent violations of safety regulations will not be entrusted with further work in this organization.

SAFETY PRECAUTIONS TO BE OBSERVED WHILE TRANSPORTING MATERIALS

I. VEHICLE

1. Vehicles carrying material should have proper registration documents and must be produced on demand by our Security Staff.
2. The light on right side, i.e., over the drivers cabin shall be in working condition.
3. Both the head lights as well as park lamps must be in working conditions.

II. MOVEMENT OF VEHICLE

1. The vehicle should not travel at more than 20 km.ph in our premises.
2. The Driver of the vehicle must possess heavy duty licence and produce on demand by the Security Staff.
3. Vehicles carrying inflammable liquids in the tank containers should have grounding chain or the tank should be coated with insulating material also to avoid Static Electricity.
4. In road junctions, speed breakers and railway crossing, the speed should be lowered and vehicle should proceed cautiously.
5. The driving should 'KEEP TO THE LEFT' at all places.
6. The vehicle should not be parked in road which could obstruct the vehicular traffic.
7. No person other than driver should be allowed to sit or stand on the prime mover or trailer.
8. The vehicle should pass only through the approved routes. Short cuts should be forbidden.
9. There must be a safe distance behind another moving truck.
10. The driver should avoid making quick starts, jerky stops or quick turns at excessive speed.

Place
Date

Signature of the Bidder
(NAME & ADDRESS WITH SEAL)



BHARAT HEAVY ELECTRICALS LIMITED

POWER PLANT PIPING UNIT

THIRUMAYAM- 622 507

CONTRACTS DEPARTMENT

Phone : 04333279551

E.mail : ilango@bheltry.co.in Website : www.bhel.com

Tender No:PPPU:WC:14:015

Tender Notice

Dt. 04.10.2014

III SHIPPING

1. Strong side supports should be provided on both sides of the trailer. The side supports should be fixed in such a way that it cannot be removed even temporarily.
2. Adequate packing must be given for easy slinging operation. The packing materials should be good enough to withstand the load.
3. The stacking of loads in the truck should be evenly placed. The load should not be heaped together or dumped over the chassis.
4. The loaded materials should be fastened tightly with 'WIRE ROPE'. Manila rope or coir rope should not at all be used. There must be side packing such as gunny or rubber tyre between the sharp edge of the job and wire rope in order to avoid cut in the wire rope.
5. There must be minimum two fastenings and it should be more in case of lengthier loads.
6. The wire rope should be in sound conditions i.e, there should not be links, knots or bristles etc.
7. The wire rope ends should be clamped with 'U' clamps.
8. The load on the truck should not be beyond its standard capacity. The carrying capacity must be clearly marked on the trailer also.
9. The loose pieces should be bundled before loading on the truck.
10. There must be red flags or red lamps for the lengthy loads which extend beyond chassis.
11. The load should not be over hanging more than 3 ft. from the end of the body.
12. The materials should not be stacked too high to avoid hitting against live electric lines.
13. While transporting the scraps, there must be wire knitting cover to prevent falling of scrap.

IV GENERAL

The vehicles should not be moved directly inside the production building in case the materials are to be unloaded there. But the vehicle should be parked outside the building and the driver should ascertain the passage as well as the unloading points with the help of shop officials. This will avoid the congestion of blocking of traffic in the gangway.

NOTICE OF ACCIDENTS

- 1) Not withstanding anything contrary to this, in the event of accident the contractor shall be required to fill injury report and submit the Engineer in charge immediately and ensure the compliances of ESI / Workmen's compensation Act, Factories Act and Rules made thereunder. He shall also maintain a register of accident as per the Act.
- 2) The Contractor shall get the contract labour engaged by him insured under Workmen's Compensation policy from General Insurance Corporation of India before actually starting

Place
Date

Signature of the Bidder
(NAME & ADDRESS WITH SEAL)



BHARAT HEAVY ELECTRICALS LIMITED

POWER PLANT PIPING UNIT

THIRUMAYAM- 622 507

CONTRACTS DEPARTMENT

Phone : 04333279551

E.mail : ilango@bheltry.co.in Website : www.bhel.com

Tender No:PPPU:WC:14:015

Tender Notice

Dt. 04.10.2014

the work of contract. The insurance coverage should be for the entire period of Contract. The Contract shall comply with the provisions of the Workmen's Compensation Act 1923. (This should be read in conjunction with the provisions of ESI Act)

BHEL SAFETY CODE

1. Suitable scaffolds shall be provided for workmen for all work that cannot safely be done from the ground, or from solid construction except such short period of work as can be done safely from ladders. When a ladder is used an extra mazdoor shall be engaged for holding the ladder and if the ladder is used for carrying materials as well, suitable footholds and hand-holds shall be provided on the ladder and the ladder shall be given an inclination not steeper than $\frac{1}{4}$ to 1 ($\frac{1}{4}$ horizontal and 1 vertical)
2. Scaffolding or staging more than 3.25 meters above the ground or floor, swung or suspended from an overhead support or erected with stationary support, shall have a guard rail properly attached, bolted, braced and otherwise secured atleast 1 meter high above the floor or platform of such scaffolding or staging and extending along the entire length of the outside and ends thereof with only such openings as may be necessary for the delivery of materials. Such scaffolding or staging shall be so fastened as to prevent it from swaying from the building or structure.
3. Working platform, gangways, and stairways shall be so constructed that they do not sag unduly or unequally, and if height of a platform or gangway or stairway is more than 3.25 meters above ground level or floor level, it shall be closely bordered have adequate width and be suitably fenced, as described in 2 above
4. Every opening in floor of a building or in a working platform shall be provided with suitable means to prevent fall of persons or materials by providing suitable fencing or railing with a minimum height of 1 meter.
5. Safe means of access shall be provided to all working platforms and other working places. Every ladder shall be securely fixed. No portable single ladder shall be over 9 meters in length. Width between side rails in a rung, ladder shall in no case be less than 30 cm, for ladders upto and including 3 metres in length. For longer ladders this width shall be increased by atleast 6 mm for each additional 30 cm. of length. Uniform step spacing shall not exceed 30 cm.
Adequate precautions shall be taken to prevent danger from electrical equipment. No materials on any of the sites shall be so stacked or placed as to cause danger or inconvenience to any person or the public. The Contractor shall provide all necessary fencing and lights to protect public from accidents and shall be bound to bear expenses of defence of every suit action or other proceedings at law that may be brought by any person for injury sustained owing to neglect of the above precautions, and pay any damages and costs which may be awarded in any such suit, action or proceeding to any such person or

Place
Date

Signature of the Bidder
(NAME & ADDRESS WITH SEAL)



BHARAT HEAVY ELECTRICALS LIMITED

POWER PLANT PIPING UNIT

THIRUMAYAM- 622 507

CONTRACTS DEPARTMENT

Phone : 04333279551

E.mail : ilango@bheltry.co.in Website : www.bhel.com

Tender No:PPPU:WC:14:015

Tender Notice

Dt. 04.10.2014

which may with the consent of the Contractor be paid to compromise any claim by any such person.

6. Excavation and Trenching:

All trenches, 1.5 metres or more in depth, shall at all times be supplied with atleast one ladder for each 30 m length or fraction thereof. Ladder shall be extended from bottom of trench to atleast 1 metre above surface of the ground. Sides of a trench 1.5 metres or more in depth shall be stepped back to give suitable slope or securely held by timber bracing, so as to avoid the danger of sides collapsing. Excavated materials shall not be placed within 1.5 metres of the edge of trench or half the depth of trench, whichever is more. Cutting shall be from top to bottom. Under no circumstances shall undermining or undercutting be done.

7. **Demolition:** Before any demolition work is commenced and also during the process of the work:

- a. All roads and open areas adjacent to the work site shall either be closed or suitably protected:
- b. No electric cable or apparatus which is liable to be a source of danger over a cable or apparatus used by the operator shall remain electrically charged.
- c. All practical steps shall be taken to prevent danger to persons employed, from risk of fire or explosion, or flooding. No floor, roof, or other part of a building shall be so overloaded with debris or materials as to render it unsafe.

8. All necessary personal safety equipment as considered adequate by the Engineer-in-Charge shall be available for use of persons employed on the site and maintained in a condition suitable for immediate use and the Contractor shall take adequate steps to ensure proper use of equipment by those concerned.

- a. Workers employed on mixing asphaltic materials cement and lime mortars/ concrete shall be provided with protective footwear and protective gloves.
- b. Those engaged in handling any material which is injurious to the eye shall be provided with protective goggles.
- c. Those engaged in welding works shall be provided with welder's protective eye-shields.
- d. Stone breaker shall be provided with protective goggles and protective clothing and seated at sufficiently safe intervals.
- e. When workers are employed in sewers and manholes which are in use, the Contractor shall ensure that manhole covers are opened and manholes are ventilated atleast for an hour before workers are allowed to get into them. Manholes so opened shall be cordoned off with suitable railing and provided with warning signals or boards to prevent accident to public.

The Contractor shall not employ men below the age of 18 and women on the work of painting with products containing lead in any form. Whenever men above the age of 18 are employed on the work of lead painting, the following precautions shall be taken:

Place
Date

Signature of the Bidder
(NAME & ADDRESS WITH SEAL)



BHARAT HEAVY ELECTRICALS LIMITED

POWER PLANT PIPING UNIT

THIRUMAYAM- 622 507

CONTRACTS DEPARTMENT

Phone : 04333279551

E.mail : ilango@bheltry.co.in Website : www.bhel.com

Tender No:PPPU:WC:14:015

Tender Notice

Dt. 04.10.2014

- i. No paint containing lead or lead products shall be used except in the form of paste or ready-made paint.
 - ii. Suitable face masks shall be supplied for use by workers when paint is applied in the form of spray or a surface having lead paint is dry rubbed and scraped.
 - iii. Overalls shall be supplied by the Contractor to workmen and adequate facilities shall be provided to enable working-painters to wash during on cessation of work.
9. When work is done near any place where there is risk of drowning, all necessary equipment shall be provided and kept ready for use and all necessary steps taken for prompt rescue of any person in danger and adequate provision made for prompt first aid treatment of all injuries likely to be sustained during the course of the work.
10. Use of hoisting machine and tackles including their attachments, anchorage and supports shall conform to the following:
- a. i. These shall be of good mechanical construction, sound material and adequate strength and free from defects and shall be kept in good working order.
ii. Every rope used in hoisting or lowering materials or as a means of suspension shall be of durable quality and adequate strength, and free from defects.
 - b. Every crane driver or hoisting appliance operator shall be properly qualified and no person under the age of 21 years shall be in charge of any hoisting machine including any scaffolding winch or give signals to operator.
 - c. In case of every hoisting machine and of every chain, ring, hook, shackle, swivel and pulley block used in hoisting or lowering or as means of suspension, safe working load shall be ascertained by adequate means. Every hoisting machine and all gear referred to above shall have the safe working load plainly marked there on, In case of a hoisting machine having a variable safe working load, each safe working load and the conditions under which it is applicable shall be clearly indicated. No part of any machine or any gear referred to above in this paragraph shall be loaded beyond the safe working load except for the purpose of testing.
 - d. In case of departmental machine, safe working load shall be notified by the Engineer-in-Charge. As regards contractor's machine the Contractor shall notify safe working load of each machine to the Engineer-in-Charge whenever he brings it to site of work and get it verified by the Engineer-in-Charge.
11. Motors, gearing, transmission, electric wiring and other dangerous parts of hoisting appliances shall be provided with efficient safeguards; hoisting appliances shall be provided with such means as will reduce to the minimum risk of accidental descent of load. Adequate

Place
Date

Signature of the Bidder
(NAME & ADDRESS WITH SEAL)



BHARAT HEAVY ELECTRICALS LIMITED

POWER PLANT PIPING UNIT

THIRUMAYAM- 622 507

CONTRACTS DEPARTMENT

Phone : 04333279551

E.mail : ilango@bheltry.co.in Website : www.bhel.com

Tender No:PPPU:WC:14:015

Tender Notice

Dt. 04.10.2014

precautions shall be taken to reduce to the minimum risk of any part of a suspended load becoming accidentally displaced. When workers are employed on electrical installations which are already energized, insulating mats, working apparel such as gloves, sleeves and boots, as may be necessary shall be provided. Workers shall not wear any rings, watches carry keys or other materials which are good conductors of electricity.

12. All scaffolds, ladders and other safety devices mentioned or described herein shall be maintained in a safe condition and no scaffold, ladder or equipment shall be altered or removed while it is in use. Adequate washing facilities shall be provided at or near the places of work.
13. These safety provision shall be brought to the notice of all concerned by display on a notice board at a prominent place at the work spot. Persons responsible for ensuring compliance with the Safety Code shall be named thereon by the Contractor.
14. To ensure effective enforcement of the rules and regulations relating to safety precautions, arrangements made by the Contractor shall be open to inspection by the Engineer-in-Charge or his representatives and the Inspecting Officers as defined in the Contractor's Labour Regulations.
15. Notwithstanding the above conditions 1 to 14, the Contractor is not exempted from the operation of any other Act or Rule in force.

PERSONNEL PROTECTIVE EQUIPMENT

NYLON SAFETY BELT

- 1 It shall be made out of Nylon Webbing of width of 45mm.
- 2 It shall be provided with Friction Buckles and Semi triangular Block Ring
- 3 It shall be provided with the Life line of 25ft. length of 10 mm dia
4. The Nylon rope with one end directly spliced to the back and the other end thimbleful and spliced with the Hook..
5. It shall be provided with ISI mark/supplied with test certificate.

ACID AND ALKALI RUBBER GOGGLE

1. It shall be made out of good quality thick Rubber with sponge lining inside.
2. It shall be suitable to fit on the face of any person.
3. It shall be fitted with clear, Non shatter able Lenses, or Toughened Lenses, in size 50 mm dia.
4. It shall give protection from splashing of chemicals and acid fumes.
5. It shall be provided with adjustable Elastic Band.

SPECTACLE TYPE SAFETY GOGGLES

Place
Date

Signature of the Bidder
(NAME & ADDRESS WITH SEAL)



BHARAT HEAVY ELECTRICALS LIMITED

POWER PLANT PIPING UNIT

THIRUMAYAM- 622 507

CONTRACTS DEPARTMENT

Phone : 04333279551

E.mail : ilango@bheltry.co.in Website : www.bhel.com

Tender No:PPPU:WC:14:015

Tender Notice

Dt. 04.10.2014

1. The Frame should be of conventional type used with good quality cellulose Acetate material with reinforcement on the sides and opaque (black in colour)
2. The Toughened Lens should be an imported one (English, White Toric, plain, Optically Neutral) and should withstand the steel-ball Impact Test with ISI mark.
3. The thickness of the Lens shall be 2.8 mm.
4. The Hinged- type Foldable Wire mesh side – pieces with good Rivets shall be provided.
5. Good; durable, Screws and Hinges on the side – legs with good workmanship must be ensured.
6. There should not be any defect either in the frame, or in the Lens, and the Goggles should be of smooth and fine surface quality.
7. The size of the goggles is to be marked with Nos. 50 & 52 respectively on the inner side of one side – leg.
8. The initials of the Maker shall be embossed on the inner side of the other Leg, to identify the firm.
9. The goggles should be packed in a good , Safety Case. Completely enclosing the goggles with a cleaner.
10. Subjected to 100% inspection.

GUM BOOTS

1. Gum Boots shall be made up of Rubber/PVC material of Duck Back/Tarzan make
2. It shall have inner lining of good quality cotton/cloth
3. It shall have the carbon steel toe cap to the thickness of 1.5mm and should withstand the impact of 14Kgs/m and provided with ISI mark/supplied with test certificate
4. It shall be covered up to the knee and give protection from splashing of chemicals, oil, water, etc.
5. It shall have the resistance to acids, alkali and oils
6. It shall be provided with ISI mark/supplied with test certificate.

GAS WELDING GOGGLES

1. They shall be made of Bakelite material with smooth finish
2. They shall have the vents on either side for allowing adequate ventilation, but preventing light and dust.
3. They shall have a pair of cups and screw cap arrangements to hold the filter lenses
4. They shall have a pair of filter lenses in size 50mm dia, shade no.6 of DIN specification to filter the IR radiation from the gas welding/cutting operation
5. They shall have two pairs of clear, protective cover (clear glass) in size 50mm dia.
6. They shall have a pair of spring type elastic band with adjustable leather strap

ACID AND ALKALI PROOF RUBBER GLOVES

1. It shall be made up of good quality, thick Rubber in size 14" and 16". Black in colour

Place
Date

Signature of the Bidder
(NAME & ADDRESS WITH SEAL)



BHARAT HEAVY ELECTRICALS LIMITED

POWER PLANT PIPING UNIT

THIRUMAYAM- 622 507

CONTRACTS DEPARTMENT

Phone : 04333279551

E.mail : ilango@bheltry.co.in Website : www.bhel.com

Tender No:PPPU:WC:14:015

Tender Notice

Dt. 04.10.2014

2. It shall give protection against acid and alkali
3. It shall be of five finger type easy wear.

HEAVY DUTY RESPIRATOR

1. It shall be made of soft PVC material so as to withstand normal usage, exposure to moisture
2. The construction shall be suitable to fit the faces of men
3. It shall have a mouth piece with White Cartridge
4. The cartridge shall be containing Sodium Hydroxide with Potassium Hydroxide
5. It shall absorb gas and afford protection against the following Vapours, gases
 - 1.Acetic acid
 2. Bromine
 - 3.Carbolic acid
 4. Carbon di oxide
 5. Chlorine
 6. Hydrochloric acid
 7. Hydrogen Chloride
 8. Iodine
 9. Nitrous gases
 10. Nitrogen di oxide
 - 11.Phosgene
 12. Sulphur di oxide
 - 13.Sulphurated Hydrogen
 14. Sulphur Trioxide
6. It shall be provided with a dust mouth piece provided with cotton pad to be provided to filter the respiration dust
7. It shall have a non return inlet valve at the mouth piece, and side outlet valves
8. It shall have adjustable Elastic Strap not less than ¾" width for holding in position without discomfort
9. It shall be light in weight
10. It shall be provided with 3 nos. spare cotton pad along with each respirator
11. It shall be provided with ISI mark/supplied with test certificate

DUST RESPIRATOR

1. It shall be made of soft PVC material so as to withstand normal usage, exposure to moisture
2. The construction shall be suitable to fit the faces of men
3. It shall have a mouth piece with cotton pad to be provided to filter the respiration dust
4. It shall have Non-return inlet valve at the mouthpiece and side outlet respiration
5. It shall have adjustable Elastic Strap not less than ¾" width for holding in position without discomfort
6. It shall be light in weight
7. It shall be provided with 3 nos. spare cotton pad along with each respirator
8. It shall be provided with ISI mark/supplied with test certificate

LIGHT FUME RESPIRATOR

1. It shall be made of soft PVC material so as to withstand normal usage, exposure to moisture
2. The construction shall be suitable to fit the faces of men

Place
Date

Signature of the Bidder
(NAME & ADDRESS WITH SEAL)



BHARAT HEAVY ELECTRICALS LIMITED

POWER PLANT PIPING UNIT

THIRUMAYAM- 622 507

CONTRACTS DEPARTMENT

Phone : 04333279551

E.mail : ilango@bheltry.co.in Website : www.bhel.com

Tender No:PPPU:WC:14:015

Tender Notice

Dt. 04.10.2014

3. It shall have a mouth piece with cotton pad and black cartridge containing activated charcoal to filter fumes from paint, oil etc.
4. It shall have Non-return inlet valve at the mouthpiece and side outlet respirable
5. It shall have adjustable Elastic Strap not less than ¾" width for holding in position without discomfort
6. It shall be light in weight
7. Spare cotton pad 3 nos. to be provided along with each respirator
8. It shall be provided with ISI mark/supplied with test certificate

INDUSTRIAL HELMETS

1. The Helmet shall be made of Fiber Glass Di-electric material with narrow brim
2. The surface of the shell shall be natural finish and Light blue colour
3. It shall have a Nape strap adjustable Head band equipped with sweat resisting lining. The width shall not be less than 30mm
4. Inner cushioning which is flexible and non absorber of water shall be provided between the head band the shell
5. It shall have ventilation gap of 10mm to 20mm
6. Inside, the dimension of the head band in the longitudinal direction shall be 20 to 25% greater than the inside dimension of the cross wise direction
7. The shell shall have a clearance of less than 30mm between the inside of the top of the crown and top of the wearer's head
8. The wearing height shall not be less than 80 mm
9. The head band shall be fitted with at least four crown straps each extending from side of the head band to the other. The width of the crown strap shall be 20mm
10. It shall have the leather chin strap , It must with stand the penetration resistance test and shock absorption test provided with ISI mark/supplied with test certificate

Place
Date

Signature of the Bidder
(NAME & ADDRESS WITH SEAL)



BHARAT HEAVY ELECTRICALS LIMITED

POWER PLANT PIPING UNIT

THIRUMAYAM- 622 507

CONTRACTS DEPARTMENT

Phone : 04333279551

E.mail : ilango@bheltry.co.in Website : www.bhel.com

Tender No:PPPU:WC:14:015

Tender Notice

Dt. 04.10.2014

SAFETY PRACTICES DURING CONSTRUCTION

CONTENTS

- 1.0 Introduction**
- 2.0 Scope**
- 3.0 Definitions**
- 4.0 General Duties**
 - 4.1 General Duties Of Execution Agencies
 - 4.2 General Duties Of Owners
- 5.0 Safety Practices At Work Places**
 - 5.1 General Provisions
 - 5.2 Means Of Access And Egress
 - 5.3 Housekeeping
 - 5.4 Precautions Against The Fall Of Materials And Persons, and Collapse Of Structures
 - 5.5 Prevention Of Unauthorised Entry
 - 5.6 Fire Prevention And Fire Fighting
 - 5.7 Lighting
 - 5.8 Plant, Machinery, Equipment and Hand Tools
- 6.0 Construction Activities**
 - 6.1 Excavation
 - 6.2 Scaffolding, Platforms & Ladders
 - 6.3 Structural Work, Laying Of Reinforcement & Concreting
 - 6.4 Road Work
 - 6.5 Cutting/Welding
 - 6.6 Working In Confined Spaces
 - 6.7 Working At Heights
 - 6.8 Handling And Lifting Equipment
 - 6.9 Vehicle Movement
- 7.0 Demolition**
 - 7.1.1 Masonry works.
- 8.0 First Aid**
- 9.0 Documentation Safety Awareness & Training**
- 10.0 List of safety codes for civil Works**

Place
Date

Signature of the Bidder
(NAME & ADDRESS WITH SEAL)



BHARAT HEAVY ELECTRICALS LIMITED

POWER PLANT PIPING UNIT

THIRUMAYAM- 622 507

CONTRACTS DEPARTMENT

Phone : 04333279551

E.mail : ilango@bheltry.co.in Website : www.bhel.com

Tender No:PPPU:WC:14:015

Tender Notice

Dt. 04.10.2014

1.0 INTRODUCTION

Safety in Construction Management deserves utmost attention. Construction is widely recognized as one of the accident-prone activities. Most of the accidents are caused by inadequate planning, failure during the construction process and/or because of design deficiencies. Besides property loss, accidents also result in injuries and fatalities to the personnel, same needs to be prevented.

The reasons for accidents during construction activities are related to unique nature of the industry, human behavior, difficult work-site conditions, extended odd duty hours, lack of training & awareness and inadequate safety management. Unsafe working methods, equipment failure and improper housekeeping also tend to increase the accident rate in construction.

Ensuring good quality of materials, equipment and competent supervision along with compliance of standard engineering practices shall go a long way to in built safety into the system.

The objective of this standard is to provide practical guidance on technical and educational framework for safety and health in construction with a view to:

- (a) prevent accidents and harmful effects on the health of workers arising from employment in construction;
- (b) ensure appropriate safety during implementation of construction;
- (c) provide safety practice guidelines for appropriate measures of planning, control and enforcement.

1.0 SCOPE

This document specifies broad guidelines on safe practices to be adhered to during construction activities. However, before commencing any job, specific hazards and its effects should be assessed and necessary corrective/preventive actions should be taken by all concerned. The document is intended only to supplement and not to replace or supersede the prevailing statutory requirements, which shall also be followed as applicable. For Personal Protective Equipment, PPE manual of TLC department shall be referred to. The scope of this document does not include the design aspects and quality checks during construction.

2.0 DEFINITIONS

Definitions of various terminology are given below:

- *Adequate, appropriate or suitable* are used to describe qualitatively or quantitatively the means or method used to protect the worker.
- *Brace*: A structural member that holds one point in a fixed position with respect to another point; bracing is a system of structural members designed to prevent distortion of a structure.
- *By hand*: The work is done without the help of a mechanised tool.
- *Competent Authority*: A statutory agency having the power to issue regulations, orders or other instructions having the force of law.

Place
Date

Signature of the Bidder
(NAME & ADDRESS WITH SEAL)



BHARAT HEAVY ELECTRICALS LIMITED

POWER PLANT PIPING UNIT

THIRUMAYAM- 622 507

CONTRACTS DEPARTMENT

Phone : 04333279551

E.mail : ilango@bheltry.co.in Website : www.bhel.com

Tender No:PPPU:WC:14:015

Tender Notice

Dt. 04.10.2014

- *Competent person:* A person possessing adequate qualifications, such as suitable training and sufficient knowledge, experience and skill for the safe performance of the specific work. The competent authorities may define appropriate criteria for the designation of such persons and may determine the duties to be assigned to them.
- *Execution agency:*
Any physical or legal person, having contractual obligation with the owner, and who employs one or more workers on a construction site
- *Owner:*
Any physical or legal person for whom construction job is carried out.
It shall also include owner's designated representative / consultant / nominee / agent, authorized from time to time to act for and on its behalf, for supervising / coordinating the activities of the execution agency.
- *Hazard:* Danger or potential danger.
- *Guard-rail:* An adequately secured rail erected along an exposed edge to prevent persons from falling.
- *Hoist:* A machine, which lifts materials or persons by means of a platform, which runs on guides.
- *Lifting gear:* Any gear or tackle by means of which a load can be attached to a lifting appliance but which does not form an integral part of the appliance or load.
- *Lifting appliance:* Any stationary or mobile appliance used for raising or lowering persons or loads.
- *Means of access or egress:* Passageways, corridors, stairs, platforms, ladders and any other means for entering or leaving the workplace or for escaping in case of danger.
- *Scaffold:* Any fixed, suspended or mobile temporary structure supporting workers and material or to gain access to any such structure and which is not a lifting appliance as defined above.
- *Toe-board:* A barrier placed along the edge of a scaffold platform, runway, etc., and secured there to guard against the slipping of persons or the falling of material.
- *Worker:* Any person engaged in construction activity.
- *Workplace:* All places where workers need to be or to go by reason of their work.

3.0 GENERAL DUTIES

4.1 GENERAL DUTIES OF EXECUTION AGENCIES

3.1.1 Execution agency should:

Place
Date

Signature of the Bidder
(NAME & ADDRESS WITH SEAL)



BHARAT HEAVY ELECTRICALS LIMITED

POWER PLANT PIPING UNIT

THIRUMAYAM- 622 507

CONTRACTS DEPARTMENT

Phone : 04333279551

E.mail : ilango@bheltry.co.in Website : www.bhel.com

Tender No:PPPU:WC:14:015

Tender Notice

Dt. 04.10.2014

- i) Provide means and organization to comply with the safety and health measures required at the workplace.
- ii) Provide and maintain workplaces, plant, equipment, tools and machinery and organize construction work so that, there is no risk of accident or injury to health of workers. In particular, construction work should be planned, prepared and undertaken so that:
 - (a) Dangers, liable to arise at the workplace, are prevented;
 - (b) Excessively or unnecessarily strenuous work positions and movements are avoided;
 - (c) Organization of work takes into account the safety and health of workers;
 - (d) Materials and products used are suitable from a safety and health point of view;
 - (e) Working methods are adopted to safeguard workers against the harmful effects of chemical, physical and biological agents.
- iii) Arrange for periodic safety inspections by competent persons of all buildings, plant, equipment, tools, machinery, workplaces and review of systems of work, regulations, standards or codes of practice. The competent person should examine and ascertain the safety of construction machinery and equipment.
- iv) Provide such supervision to ensure that workers perform their work with due regard to safety and health of theirs as well as that of others.
- v) Employ only those workers who are qualified, trained and suited by their age, physique, state of health and skill.
- vi) Satisfy themselves that all workers are informed and instructed in the hazards connected with their work and environment and trained in the precautions necessary to avoid accidents and injury to health.
- vii) Ensure that buildings, plant, equipment, tools, machinery or workplaces in which a dangerous defect has been found should not be used until the defect has been rectified.
- viii) Organize for and remain always prepared to take immediate steps to stop the operation and evacuate workers as appropriate, where there is an imminent danger to the safety of workers.
- ix) Establish a checking system by which it can be ascertained that all the members of a shift, including operators of mobile equipment, have returned to the camp or base at the close of work on dispersed sites and where small groups of workers operate in isolation.
- x) Provide appropriate first aid, training and welfare facilities to workers as per various statutes like the Factories Act, 1948 etc. and, whenever collective measures are not feasible or are insufficient, provide and maintain personal protective equipment and clothing in line with the requirement as per PPE Manual of TLC Department. They should also provide access to workers to occupational health services.
- xi) Educate workers about their right and the duty at any workplace to participate in ensuring safe working conditions to the extent of their control over the equipment and methods of work and to express views on working procedures adopted as may affect safety and health.

Place
Date

Signature of the Bidder
(NAME & ADDRESS WITH SEAL)



BHARAT HEAVY ELECTRICALS LIMITED

POWER PLANT PIPING UNIT

THIRUMAYAM- 622 507

CONTRACTS DEPARTMENT

Phone : 04333279551

E.mail : ilango@bheltry.co.in Website : www.bhel.com

Tender No:PPPU:WC:14:015

Tender Notice

Dt. 04.10.2014

- xii) Ensure that except in an emergency, workers, unless duly authorized, should not interfere with, remove, alter or displace any safety device or other appliance furnished for their protection or the protection of others, or interfere with any method or process adopted with a view to avoiding accidents and injury to health.
- xiii) Ensure that workers do not operate or interfere with plant and equipment that they have not been
duly authorised to operate, maintain or use.
- xiv) Ensure that workers do not sleep, rest or cook etc in dangerous places such as scaffolds, railway tracks, garages, confined spaces or in the vicinity of fires, dangerous or toxic substances, running machines or vehicles and heavy equipment etc.
- xvii) Obtain the necessary clearance / permits as required and specified by owner

4.2 GENERAL DUTIES OF OWNERS

4.2.1 Owners should:

- i) co-ordinate or nominate a competent person to co-ordinate all activities relating to safety and health on their construction projects;
- ii) Inform all contractors on the project of special risks to health and safety;
- iii) Ensure that executing agency is aware of the owner's requirements and the executing agency's responsibilities with respect to safety practices before starting the job.

5.0 SAFETY PRACTICES AT WORK PLACES

5.1. GENERAL PROVISIONS

- 5.1.1 All openings and other areas likely to pose danger to workers should be clearly indicated.
- 5.1.2 Workers & Supervisors should use the safety helmet and other requisite Personal Protective Equipment according to job & site requirement. They should be trained to use personal protective equipment.
- 5.1.3 Never use solvents, alkalis and other oils to clean the skin.
- 5.1.4 Lift the load with back straight and knees bent as far as possible. Seek the help in case of heavy load.
- 5.1.5 Ensure the usage of correct and tested tools and tackles. Don't allow the make shift tools and tackles.
- 5.1.6 No loose clothing should be allowed while working near rotating equipment or working at heights.

5.2 MEANS OF ACCESS AND ENGRESS

Place
Date

Signature of the Bidder
(NAME & ADDRESS WITH SEAL)



BHARAT HEAVY ELECTRICALS LIMITED

POWER PLANT PIPING UNIT

THIRUMAYAM- 622 507

CONTRACTS DEPARTMENT

Phone : 04333279551

E.mail : ilango@bheltry.co.in Website : www.bhel.com

Tender No:PPPU:WC:14:015

Tender Notice

Dt. 04.10.2014

Adequate and safe means of access (at least two, differently located) to and egress from all workplaces should be provided. Same should be displayed and maintained.

5.3 HOUSEKEEPING

5.3.1 Ensure:

- i) proper storage of materials and equipment;
- ii) removal of scrap, inflammable material, waste and debris at appropriate intervals.

5.3.2 Removal of loose materials, which are not required for use, to be ensured. Accumulation of these at the site can obstruct means of access to and egress from workplaces and passageways.

5.3.3 Workplaces and passageways, that are slippery owing to oil, grease or other causes, should be cleaned up or strewn with sand, sawdust, ash etc.

5.4 PRECAUTIONS AGAINST THE FALL OF MATERIALS & PERSONS AND COLLAPSE OF STRUCTURES

7.1.2 Precautions should be taken such as the provision of fencing, look-out men or barriers to protect any person against injury by the fall of materials, or tools or equipment being raised or lowered.

5.4.2 Where necessary to prevent danger, guys, stays or supports should be used or other effective precautions should be taken to prevent the collapse of structures or parts of structures that are being erected, maintained, repaired, dismantled or demolished.

5.4.4 All openings through which workers are liable to fall should be kept effectively covered or fenced and displayed prominently.

5.4.5 As far as practicable, guardrails and toe-boards should be provided to protect workers from falling from elevated workplaces.

5.5 PREVENTION OF UNAUTHORISED ENTRY

5.5.1 Construction sites located in built-up areas and alongside vehicular and pedestrian traffic routes should be fenced to prevent the entry of unauthorized persons.

5.5.2 Visitors should not be allowed access to construction sites unless accompanied by or authorised by a competent person and provided with the appropriate protective equipment.

5.6 FIRE PREVENTION AND FIRE FIGHTING

5.6.1 All necessary measures should be taken by the executing agency and owner to:

- i) avoid the risk of fire;
- ii) control quickly and efficiently any outbreak of fire;
- iii) bring out a quick and safe evacuation of persons.
- iv) Inform unit/fire station control room, where construction work is carried out within existing operating area.

Place
Date

Signature of the Bidder
(NAME & ADDRESS WITH SEAL)



BHARAT HEAVY ELECTRICALS LIMITED

POWER PLANT PIPING UNIT

THIRUMAYAM- 622 507

CONTRACTS DEPARTMENT

Phone : 04333279551

E.mail : ilango@bheltry.co.in Website : www.bhel.com

Tender No:PPPU:WC:14:015

Tender Notice

Dt. 04.10.2014

5.6.2 Combustible materials such as packing materials, sawdust, greasy/oily waste and scrap wood or plastics should not be allowed to accumulate in workplaces but should be kept in closed metal containers in a safe place.

5.6.3 Places where workers are employed should, if necessary to prevent the danger of fire, be provided with:

- i) suitable and sufficient fire-extinguishing equipment, which should be easily visible and accessible;
- ii) an adequate water supply at sufficient pressure meeting the requirements.

5.6.4 To guard against danger at places having combustible material, workers should be trained in the action to be taken in the event of fire, including the use of means of escape.

5.6.5 At sites having combustible material, suitable visual signs should be provided to indicate clearly the direction of escape in case of fire.

5.6.6 Means of escape should be kept clear at all times. Escape routes should be frequently inspected particularly in high structures and where access is restricted.

5.7 LIGHTING

5.7.1 Where natural lighting is not adequate, working light fittings or portable hand-lamps should be provided at workplace on the construction site where a worker will do a job.

5.7.2 Emergency lighting should be provided for personnel safety during night time to facilitate standby lighting source, if normal system fails.

5.7.2 Artificial lighting should not produce glare or disturbing shadows.

5.7.3 Lamps should be protected by guards against accidental breakage.

5.7.4 The cables of portable electrical lighting equipment should be of adequate size & characteristics for the power requirements and of adequate mechanical strength to withstand severe conditions in construction operations.

5.8 PLANT, MACHINERY, EQUIPMENT AND HAND TOOLS

5.8.1 General Provisions

- i) Plant, machinery and equipment including hand tools, both manual and power driven, should:
 - a) be of proper design and construction, taking into account health, Safety and ergonomic principles.
 - b) be maintained in good working order;
 - c) be used only for work for which they have been designed.
 - d) be operated only by workers who have been authorized and given appropriate training.
 - e) be provided with protective guards, shields or other devices as required.
- iii) Adequate instructions for safe use should be provided.

Place
Date

Signature of the Bidder
(NAME & ADDRESS WITH SEAL)



BHARAT HEAVY ELECTRICALS LIMITED

POWER PLANT PIPING UNIT

THIRUMAYAM- 622 507

CONTRACTS DEPARTMENT

Phone : 04333279551

E.mail : ilango@bheltry.co.in Website : www.bhel.com

Tender No:PPPU:WC:14:015

Tender Notice

Dt. 04.10.2014

- iii) Safe operating procedures should be established and used for all plant, machinery and equipment.
- iv) Operators of plant, machinery and equipment should not be distracted while work is in progress.
- v) Plant, machinery and equipment should be switched off when not in use and isolated before any adjustment, clearing or maintenance is done.
- vi) Where trailing cables or hose pipes are used they should be kept as short as practicable and not allowed to create a hazard.
- vii) All moving parts of machinery and equipment should be enclosed or adequately guarded.
- viii) Every power-driven machine and equipment should be provided with adequate means, immediately accessible and readily identifiable to the operator, of stopping it quickly and preventing it from being started again inadvertently.
- ix) Operators of plant, machinery, equipment and tools should be provided with PPEs, including where necessary, suitable ear protection.

5.8.2 Hand tools

- i) Hand tools should be repaired by competent persons.
- ii) Heads of hammers and other shock tools should be dressed or ground to a suitable radius on the edge as soon as they begin to mushroom or crack.
- iii) When not in use and while being carried or transported sharp tools should be kept in sheaths, shields, chests or other suitable containers.
- iv) Only insulated or non-conducting tools should be used on or near live electrical installations.
- v) Only non-sparking tools should be used near or in the presence of flammable or explosive dusts or vapours.

5.8.3 Pneumatic Tools

- i) Operating triggers on portable pneumatic tools should be:
 - a) so placed as to minimize the risk of accidental starting of the machine.
 - b) so arranged as to close the air inlet valve automatically when the pressure of the operator's hand is removed.
- ii) Hose and hose connections for compressed air supply to portable pneumatic tools should be:
 - a) designed and tested for the pressure and service for which they are intended;
 - b) fastened securely on the pipe outlet and equipped with the safety chain, as appropriate.
- iv) Pneumatic shock tools should be equipped with safety clips or retainers to prevent dies and tools from being accidentally expelled from the barrel.

Place
Date

Signature of the Bidder
(NAME & ADDRESS WITH SEAL)



BHARAT HEAVY ELECTRICALS LIMITED

POWER PLANT PIPING UNIT

THIRUMAYAM- 622 507

CONTRACTS DEPARTMENT

Phone : 04333279551

E.mail : ilango@bheltry.co.in Website : www.bhel.com

Tender No:PPPU:WC:14:015

Tender Notice

Dt. 04.10.2014

- v) Pneumatic tools should be disconnected from power and the pressure in hose lines released before any adjustment or repair is made.

5.8.4 Electrical Tools

- i) Low voltage portable electrical tools should generally be used.
ii) All electrical tools should be earthed, unless they are "all insulated" or "double insulated" tools which do not require earthing.
iii) All electrical tools should get inspected and maintained on a regular basis by a competent electrician and complete records kept.

5.8.5 Engines

- i) Engines should:
a) be installed so that they can be started safely and the maximum safe speed cannot be exceeded.
b) have controls for limiting speed.
c) have devices to stop them from a safe place in an emergency.
ii) IC engines should not be run in confined spaces unless adequate exhaust ventilation is provided.
iii) When IC engines are being fuelled:the engine should be shut off.
a) care should be taken to avoid spilling fuel;
b) no person should smoke or have a naked light in the vicinity.
c) a fire extinguisher should be kept readily available.
iv) Secondary fuel reservoir should be placed outside the engine room.

6.0 CONSTRUCTION ACTIVITIES

The various common activities in construction are as under:

- Excavation
- Scaffolding, Platforms & Ladders
- Structural Work, Laying of Reinforcement & Concreting
- Road Work
- Cutting /Welding
- Working in Confined Space
- Working at Heights
- Handling & Lifting Equipments
- Vehicle Movement
- Demolition
- Masonry Works

Place
Date

Signature of the Bidder
(NAME & ADDRESS WITH SEAL)



BHARAT HEAVY ELECTRICALS LIMITED

POWER PLANT PIPING UNIT

THIRUMAYAM- 622 507

CONTRACTS DEPARTMENT

Phone : 04333279551

E.mail : ilango@bheltry.co.in Website : www.bhel.com

Tender No:PPPU:WC:14:015

Tender Notice

Dt. 04.10.2014

The safe practices to be followed during the implementation of above construction activities are given below:

6.1 EXCAVATION

6.1.1 All excavation work should be planned and the method of excavation and the type of support work required should be decided considering the following:

- i) the stability of the ground;
- ii) the excavation will not affect adjoining buildings, structures or roadways;
- iii) to prevent hazard, the gas, water, electrical and other public utilities should be shut off or disconnected, if necessary;
- iv) presence of underground pipes, cable conductors, etc.,
- v) the position of culvert/bridges, temporary roads and spoil heaps should be determined;

6.1.2 Before digging begins on site, all excavation work should be planned and the method of excavation and the type of support work required decided.

Safe work permit in the prescribed format 310-013 should be obtained prior to commencement.

6.1.3 All excavation work should be supervised.

6.1.4 Sites of excavations should be thoroughly inspected:

- i) daily, prior to each shift and after interruption in work of more than one day;
- ii) after every blasting operation;
- iii) after an unexpected fall of ground;
- iv) after substantial damage to supports;
- v) after a heavy rain, frost or snow;
- vi) when boulder formations are encountered.

6.1.4 Safe angle of repose while excavating trenches exceeding 1.5m depth upto 3.0m should be maintained. Based on site conditions, provide proper slope, usually 45° , and suitable bench of 0.5m width at every 1.5m depth of excavation in all soils except hard rock or provide proper shoring and strutting to prevent cave-in or slides.

6.1.6 As far as possible, excavated earth should not be placed within one meter of the edge of the trench or depth of trench whichever is greater.

6.1.7 Don't allow vehicles to operate too close to excavated area. Maintain atleast 2m distance from edge of excavation. No load, plant or equipment should be placed or moved near the edge of any excavation where it is likely to cause its collapse and thereby endanger any person unless precautions such as the provision of shoring or piling are taken to prevent the sides from collapsing.

Place
Date

Signature of the Bidder
(NAME & ADDRESS WITH SEAL)



BHARAT HEAVY ELECTRICALS LIMITED

POWER PLANT PIPING UNIT

THIRUMAYAM- 622 507

CONTRACTS DEPARTMENT

Phone : 04333279551

E.mail : ilango@bheltry.co.in Website : www.bhel.com

Tender No:PPPU:WC:14:015

Tender Notice

Dt. 04.10.2014

- 6.1.8 Adequately anchored stop blocks and barriers should be provided to prevent vehicles being driven into the excavation. Heavy vehicles should not be allowed near the excavation unless the support work has been specially designed to permit it.
- 6.1.9 If an excavation is likely to affect the security of a structure on which persons are working, precautions should be taken to protect the structure from collapse.
- 6.1.10 Barricade at 1m height (with red & white band/self glowing caution board) should be provided for excavations beyond 1.5m depth. Provide two entries/exits for such excavation.
- 6.1.13 Necessary precautions should be taken for underground utility lines like cables, sewers etc. and necessary approvals/clearances from the concerned authorities shall be obtained before commencement of the excavation job.
- 6.1.14 Water shall be pumped/bailed out, if any accumulates in the trench. Necessary precautions should be taken to prevent entry of surface water in trenches.
- 6.1.15 During rains, the soil becomes loose. Take additional precaution against collapse of side wall.
- 6.1.16 In case of mechanized excavation, precaution shall be taken not to allow anybody to come within one meter of extreme reach of the mechanical shovel. The mechanised excavator shall be operated by a well-trained experienced operator. When not in operation, the machine shall be kept on firm leveled ground with mechanical shovel resting on ground. Wheel or belt shall be suitably jammed to prevent any accidental movement of the machine. Suitable precautions as per manufacturer guidelines should be taken for dozers, graders and other heavy machines.
- 6.1.15 In case of blasting, follow strictly IS:4081-1986 & Indian Explosive Act and rules for storage, handling and carrying of explosive materials and execution of blasting operation.

6.2 SCAFFOLDING, PLATFORMS & LADDERS

6.2.1 Metal as material of construction

- i) A scaffold should be provided and maintained or other equally safe and suitable provision should be made where work cannot safely be done on or from the ground or from part of a building or other permanent structure.
- ii) Scaffolds should be provided with safe means of access, such as stairs, ladders or ramps. Ladders should be secured against inadvertent movement.
- iii) Every scaffold should be constructed, erected and maintained so as to prevent collapse or accidental displacement when in use.
- iv) Every scaffold and part thereof should be constructed :
- (a) in such a way so as not to cause hazards for workers during erection and dismantling;
- (b) in such a way so as guard rails and other protective devices, platforms, ladders, stairs or ramps can be easily put together;
- (c) with sound material and of requisite size and strength for the purpose for which it is to be used and maintained in a proper condition.

Place
Date

Signature of the Bidder
(NAME & ADDRESS WITH SEAL)



BHARAT HEAVY ELECTRICALS LIMITED

POWER PLANT PIPING UNIT

THIRUMAYAM- 622 507

CONTRACTS DEPARTMENT

Phone : 04333279551

E.mail : ilango@bheltry.co.in Website : www.bhel.com

Tender No:PPPU:WC:14:015

Tender Notice

Dt. 04.10.2014

- v) Boards and planks used for scaffolds should be protected against splitting.
- vi) Materials used in the construction of scaffolds should be stored under good conditions and apart from any material unsuitable for scaffolds.
- vii) Couplers should not cause deformation in tubes. Couplers should be made of drop forged steel or equivalent material.
- viii) Tubes should be free from cracks, splits and excessive corrosion and be straight to the eye, and tube ends cut cleanly square with the tube axis.
- ix) Scaffolds should be designed for their maximum load as per relevant code.
- x) Scaffolds should be adequately braced.
- xi) Scaffolds which are not designed to be independent should be rigidly connected to the building at designated vertical and horizontal places.
- xii) A scaffold should never extend above the highest anchorage to an extent which might endanger its stability and strength.
- xiii) Loose bricks, drainpipes, chimney-pots or other unsuitable material should not be used for the construction or support of any part of a scaffold.
- xiv) Scaffolds should be inspected and certified:
 - (a) before being taken into use;
 - (b) at periodic intervals thereafter as prescribed for different types of scaffolds;
 - (c) after any alteration, interruption in use, exposure to weather or seismic conditions or any other occurrence likely to have affected their strength or stability.
- xv) Inspection should more particularly ascertain that:
 - (a) the scaffold is of suitable type and adequate for the job;
 - (b) materials used in its construction are sound and of sufficient strength;
 - (c) it is of sound construction and stable;
 - (d) that the required safeguards are in position.
- xvi) A scaffold should not be erected, substantially altered or dismantled except by or under the supervision.
- xvii) Every scaffold should be maintained in good and proper condition, and every part should be kept fixed or secured so that no part can be displaced in consequence of normal use.

6.2.2 Lifting appliances on scaffolds

- i) When a lifting appliance is to be used on a scaffold:

Place
Date

Signature of the Bidder
(NAME & ADDRESS WITH SEAL)



BHARAT HEAVY ELECTRICALS LIMITED

POWER PLANT PIPING UNIT

THIRUMAYAM- 622 507

CONTRACTS DEPARTMENT

Phone : 04333279551

E.mail : ilango@bheltry.co.in Website : www.bhel.com

Tender No:PPPU:WC:14:015

Tender Notice

Dt. 04.10.2014

- (a) the parts of the scaffold should be carefully inspected to determine the additional strengthening and other safety measures required;
- (b) any movement of the scaffold members should be prevented;
- (c) if practicable, the uprights should be rigidly connected to a solid part of the building at the place where the lifting appliance is erected.

6.2.3 Prefabricated scaffolds

- i) In the case of prefabricated scaffold systems, the instructions provided by the manufacturers or suppliers should be strictly adhered to. Prefabricated scaffolds should have adequate arrangements for fixing bracing.
- ii) Frames of different types should not be intermingled in a single scaffold.
- iii) Scaffolding shall be erected on firm and level ground.
- iv) All members of metal scaffolding shall be checked periodically to screen out defective / rusted members. All joints should be properly lubricated for easy tightening.
- v) Entry to scaffolding should be restricted.
- vi) Erection, alteration and removal shall be done under supervision of experienced personnel.
- vii) Use of barrels, boxes, loose bricks etc., for supporting platform shall not be permitted.
- viii) Each supporting member of platform shall be securely fastened and braced
- ix) Where planks are butt-joined, two parallel putlogs shall be used, not more than 100mm apart, to give support to each plank.
- x) Platform plank shall not project beyond its end support to a distance exceeding 4 times the thickness of plank, unless it is effectively secured to prevent tipping. Cantilever planks should be avoided.
- xi) The platform edges shall be provided with 150mm high toe board to eliminate hazards of tools or other objects falling from platform.
- xii) Erect ladders in the "four up-one out position"
- xiii) Lash ladder secured with the structure.
- xiv) Using non-slip devices, such as, rubber shoes or pointed steel ferules at the ladder foot, rubber wheels at ladder top, fixing wooden battens, cleats etc.
- xv) When ladder is used for climbing over a platform, the ladder must be of sufficient length, to extend at least one meter above the platform, when erected against the platform in "four up-one out position."
- xvi) Portable ladders shall be used for heights not more than 4mt. Above 4mt flights, fixed ladders shall be provided with at least 600 mm landings at every 6mt or less.
- xvii) The width of ladder shall not be less than 300mm and rungs shall be spaced not more than 300mm.

Place
Date

Signature of the Bidder
(NAME & ADDRESS WITH SEAL)



BHARAT HEAVY ELECTRICALS LIMITED

POWER PLANT PIPING UNIT

THIRUMAYAM- 622 507

CONTRACTS DEPARTMENT

Phone : 04333279551

E.mail : ilango@bheltry.co.in Website : www.bhel.com

Tender No:PPPU:WC:14:015

Tender Notice

Dt. 04.10.2014

- xviii) Every platform and means of access shall be kept free from obstruction.
- xix) If grease, mud, gravel, mortar etc., fall on platform or scaffolds, these shall be removed immediately to avoid slippage.
- xx) Workers shall not be allowed to work on scaffolds during storms or high wind. After heavy rain or storms, scaffolds shall be inspected before reuse.
- xxi) Don't overload the scaffolding. Remove excess material and scrap immediately.
- xxii) Dismantling of scaffolds shall be done in a pre-planned sequential manner.

6.2.4 Suspended scaffolds / boatswain's chair

- i) In addition to the requirements for scaffolds in general as regards soundness, stability and protection against the risk of falls, suspended scaffolds should meet the following specific requirements.
 - (a) platforms should be designed and built with dimensions that are compatible with the stability of the structure as a whole, especially the length;
 - (b) the number or anchorage should be compatible with the dimensions of the platform;
 - (c) the safety of workers should be safeguarded by an extra rope having a point of attachment independent of the anchorage arrangements of the scaffold;
 - (d) the anchorage and other elements of support of the scaffold should be designed and built in such a way as to ensure sufficient strength;
 - (e) the ropes, winches, pulleys or pulley blocks should be designed, assembled, used and maintained according to the requirements established for lifting gear adapted to the lifting of persons according to national laws and regulations;
 - (f) Before use, the whole structure should be checked by a competent person.

6.2.5 Bamboo / Casuarina Scaffolding

- i) In general, it should be avoided as far as possible.
- ii) For construction and maintenance of residential and office buildings, bamboo / Casuarinas scaffold, if used, should conform to provisions given in IS-3696 (Part 1)-1987.

6.3 STRUCTURAL WORK, LAYING OF REINFORCEMENT AND CONCRETING

6.3.1 General provisions

- i) The erection or dismantling of buildings, structures, civil engineering works, formwork, false work and shoring should be carried out by trained workers only under the supervision of a competent person.
- ii) Precautions should be taken to guard against danger to workers arising from any temporary state of weakness or instability of a structure.
- iii) Formwork, false work and shoring should be so designed, constructed and maintained that it will safely support all loads that may be imposed on it.

Place
Date

Signature of the Bidder
(NAME & ADDRESS WITH SEAL)



BHARAT HEAVY ELECTRICALS LIMITED

POWER PLANT PIPING UNIT

THIRUMAYAM- 622 507

CONTRACTS DEPARTMENT

Phone : 04333279551

E.mail : ilango@bheltry.co.in Website : www.bhel.com

Tender No:PPPU:WC:14:015

Tender Notice

Dt. 04.10.2014

- iv) Formwork should be so designed and erected that working platforms, means of access, bracing and means of handling and stabilizing are easily fixed to the formwork structure.

6.3.2. Erection and dismantling of steel and prefabricated structures

- i) The safety of workers employed on the erection and dismantling of steel and prefabricated structures should be ensured by appropriate means, such as provision and use of:
- (a) ladders, gangways or fixed platforms;
 - (b) platforms, buckets, boatswain's chairs or other appropriate means suspended from lifting appliances;
 - (c) safety harnesses and lifelines, catch nets or catch platforms;
- ii) Steel and prefabricated structures should be so designed and made that they can be safely transported and erected.
- iii) In addition to the need for the stability of the part when erected, the design should explicitly take following into account:
- (a) the conditions and methods of attachment in the operations of transport, storing and temporary support during erection or dismantling as applicable;
 - (b) Methods for the provision of safeguards such as railings and working platforms, and, when necessary, for mounting them easily on the structural steel or prefabricated parts.
- iv) The hooks and other devices built in or provided on the structural steel or prefabricated parts that are required for lifting and transporting them should be so shaped, dimensioned and positioned as:
- (a) to withstand with a sufficient margin the stresses to which they are subjected;
 - (b) Not to set up stresses in the part that could cause failures, or stresses in the structure itself not provided for in the plans, and be designed to permit easy release from the lifting appliance. Lifting points for floor and staircase units should be located (recessed if necessary) so that they do not protrude above the surface;
 - (c) To avoid imbalance or distortion of the lifted load.
- v) Storeplaces should be so constructed that:
- (a) there is no risk of structural steel or prefabricated parts falling or overturning;
 - (b) storage conditions generally ensure stability and avoid damage having regard to the method of storage and atmospheric conditions;
 - (c) racks are set on firm ground and designed so that units cannot move accidentally.
- vi) While they are being stored, transported, raised or set down, structural steel or prefabricated parts should not be subjected to stresses prejudicial to their stability.
- vii) Every lifting appliance should:
- (a) be suitable for the operations and not be capable of accidental disconnection;
 - (b) be approved or tested as per statutory requirement.

Place
Date

Signature of the Bidder
(NAME & ADDRESS WITH SEAL)



BHARAT HEAVY ELECTRICALS LIMITED

POWER PLANT PIPING UNIT

THIRUMAYAM- 622 507

CONTRACTS DEPARTMENT

Phone : 04333279551

E.mail : ilango@bheltry.co.in Website : www.bhel.com

Tender No:PPPU:WC:14:015

Tender Notice

Dt. 04.10.2014

- viii) Lifting hooks should be of the self-closing type or of a safety type and should have the maximum permissible load marked on them.
- ix) Tongs, clamps and other appliances for lifting structural steel and prefabricated parts should:
 - (a) be of such shape and dimensions as to ensure a secure grip without damaging the part;
 - (b) be marked with the maximum permissible load in the most unfavourable lifting conditions.
- x) Structural steel or prefabricated parts should be lifted by methods or appliances that prevent them from spinning accidentally.
- xi) When necessary to prevent danger, before they are raised from the ground, structural steel or prefabricated parts should be provided with safety devices such as railings and working platforms to prevent falls of persons.
- xii) While structural steel or prefabricated parts are being erected, the workers should be provided with appliances for guiding them as they are being lifted and set down, so as to avoid crushing of hands and to facilitate the operations. Use of such appliances should be ensured.
- xiii) A raised structural steel or prefabricated part should be so secured and wall units so propped that their stability cannot be imperiled, even by external agencies such as wind and passing loads before its release from the lifting appliance.
- xiv) At work places, instruction should be given to the workers on the methods, arrangements and means required for the storage, transport, lifting and erection of structural steel or prefabricated parts, and, before erection starts, a meeting of all those responsible should be held to discuss and confirm the requirements for safe erection.
- xv) During transportation within the construction area, attachments such as slings and stirrups mounted on structural steel or prefabricated parts should be securely fastened to the parts.
- xvi) Structural steel or prefabricated parts should be so transported that the conditions do not affect the stability of the parts or the means of transport result in jolting, vibration or stresses due to blows, or loads of material or persons.
- xvii) When the method of erection does not permit the provision of other means of protection against fall of persons, the workplaces should be protected by guardrails, and if appropriate by toe-boards.
- xviii) When adverse weather conditions such as snow, ice and wind or reduced visibility entail risks of accidents, the work should be carried on with particular care, or, if necessary, interrupted.
- xix) Structures should not be worked on during violent storms or high winds, or when they are covered with ice or snow, or are slippery from other causes.
- xx) If necessary, to prevent danger, structural steel parts should be equipped with attachments for suspended scaffolds, lifelines or safety harnesses and other means of protection.

Place
Date

Signature of the Bidder
(NAME & ADDRESS WITH SEAL)



BHARAT HEAVY ELECTRICALS LIMITED

POWER PLANT PIPING UNIT

THIRUMAYAM- 622 507

CONTRACTS DEPARTMENT

Phone : 04333279551

E.mail : ilango@bheltry.co.in Website : www.bhel.com

Tender No:PPPU:WC:14:015

Tender Notice

Dt. 04.10.2014

- xxi) The risks of falling, to which workers moving on high or sloping girders are exposed, should be limited by all means of adequate collective protection or, where this is impossible, by the use of a safety harness that is well secured to a strong support.
- xxii) Structural steel parts that are to be erected at a great height should as far as practicable be assembled on the ground.
- xxiii) When structural steel or prefabricated parts are being erected, a sufficiently extended area underneath the workplace should be barricaded or guarded
- xxiv) Steel trusses that are being erected should be adequately shored, braced or guyed until they are permanently secured in position.
- xxv) Load-bearing structural member should not be dangerously weakened by cutting, holing or other means.
- xxvi) Structural members should not be forced into place by the hoisting machine while any worker is in such a position that he could be injured by the operation.
- xxvii) Open-web steel joists that are hoisted singly should be directly placed in position and secured against dislodgment.

6.3.3 Reinforcement

- i) Ensure that workers use Personnel Protective equipment like safety helmet, safety shoes, gloves etc.
- ii) Don't place the hand below the rods for checking clear distance. Use measuring devices.
- iii) Don't wear loose clothes while checking the rods.
- iv) Don't stand unnecessarily on cantilever rods.
- v) To carry out welding/cutting of rods, safety procedures/precautions as mentioned in Item No. 6.5 to be followed.

- vi) For supplying of rods at heights, proper staging and/or bundling to be provided.
- vii) Ensure barricading and staging for supplying and fixing of rods at height.
- viii) For short distance carrying of materials on shoulders, suitable pads to be provided.
- ix) While transporting material by trucks/trailers, the rods shall not protrude in front of or by the sides of driver's cabin. In case such protrusion cannot be avoided behind the deck, then it should not extend 1/3rd of deck length or 1.5M which ever is less and tied with red flags/lights.

6.3.4 Concreting

Place
Date

Signature of the Bidder
(NAME & ADDRESS WITH SEAL)



BHARAT HEAVY ELECTRICALS LIMITED

POWER PLANT PIPING UNIT

THIRUMAYAM- 622 507

CONTRACTS DEPARTMENT

Phone : 04333279551

E.mail : ilango@bheltry.co.in Website : www.bhel.com

Tender No:PPPU:WC:14:015

Tender Notice

Dt. 04.10.2014

- i) Ensure stability of shuttering work before allowing concreting.
- ii) Barricade the concreting area while pouring at height/depths.
- iii) Keep vibrator hoses, pumping concrete accessories in healthy conditions and mechanically locked.
- iv) Pipelines in concrete pumping system shall not be attached to temporary structures such as scaffolds and formwork support as the forces and movements may effect their integrity.
- v) Check safety cages & guards around moving motors/parts etc. provided in concreting mixers.
- vi) Use Personal Protective Equipment like gloves, safety shoes etc. asun OCP:FYC:002 while dealing with concrete and wear respirators for dealing with cement.
- vii) Earthing of electrical mixers, vibrators, etc. should be done and verified.
- viii) Cleaning of rotating drums of concrete mixers shall be done from outside. Lockout devices shall be provided where workers need to enter.
- ix) Where concrete mixers are driven by internal combustion engine, exhaust points shall be located away from the worker's workstation so as to eliminate their exposure to obnoxious fumes.
- x) Don't allow unauthorized person to stand under the concreting area.
- xi) Ensure adequate lighting arrangements for carrying out concrete work during night.
- xii) Don't allow the same workers to pour concrete round the clock. Insist on shift pattern.
- xiii) During pouring, shuttering and its supports should be continuously watched for defects.

6.4 ROAD WORK

- 6.4.1 Site shall be barricaded and provided with warning signs, including night warning lamps at appropriate locations for traffic diversion.
- 6.4.2 Filled and empty bitumen drums shall be stacked separately at designated places.
- 6.4.3 Mixing aggregate with bitumen shall preferably be done with the help of bitumen batch mixing plant, unless operationally non-feasible.
- 6.4.4 Road rollers, Bitumen sprayers, Pavement finishers shall be driven by experienced drivers with valid driving license.
- 6.4.5 Workers handling hot bitumen sprayers or spreading bitumen aggregate mix or mixing bitumen with aggregate, shall be provided with PVC hand gloves and rubber shoes with legging up to knee joints.
- 6.4.6 At the end of day's work, surplus hot bitumen in tar boiler shall be properly covered by a metal sheet, to prevent anything falling in it,
- 6.4.7 If bitumen accidentally falls on ground, it shall be immediately covered by sprinkling sand, to prevent anybody stepping on it. Then it shall be removed with the help of spade.

Place
Date

Signature of the Bidder
(NAME & ADDRESS WITH SEAL)



BHARAT HEAVY ELECTRICALS LIMITED

POWER PLANT PIPING UNIT

THIRUMAYAM- 622 507

CONTRACTS DEPARTMENT

Phone : 04333279551

E.mail : ilango@bheltry.co.in Website : www.bhel.com

Tender No:PPPU:WC:14:015

Tender Notice

Dt. 04.10.2014

6.4.8 For cement concrete roads, besides site barricading and installation of warning signs for traffic diversion, safe practices mentioned in the chapter on "Concreting", shall also be applicable.

6.5 CUTTING/WELDING

6.5.1 Common hazards involved in welding/cutting are sparks, molten metal, flying particles, harmful light rays, electric shocks etc. Following precautions should be taken after getting safe work permit in form 310-016 :-

- i) A dry chemical type fire extinguisher shall be made available in the work area.
- ii) Adequate ventilation shall be ensured by opening manholes and fixing a shield or forced circulation of air etc, while doing a job in confined space.
- iii) Ensure that only approved and well-maintained apparatus, such as torches, manifolds, regulators or pressure reducing valves, and acetylene generators, be used.
- iv) All covers and panels shall be kept in place, when operating an electric Arc welding machine.
- v) The work piece should be connected directly to Power supply, and not indirectly through pipelines/structures/equipments etc.
- vi) The welding receptacles shall be rated for 63 A suitable for 415V, 3-Phase system with a scraping earth. Receptacles shall have necessary mechanical interlocks and earthing facilities.
- vii) All cables, including welding and ground cables, shall be checked for any worn out or cracked insulation before starting the job. Ground cable should be separate without any loose joints.
- viii) Cable coiling shall be maintained at minimum level, if not avoidable.
- ix) An energised electrode shall not be left unattended.
- x) The power source shall be turned off at the end of job.
- xi) All gas cylinders shall be properly secured in upright position.
- xii) Acetylene cylinder shall be turned and kept in such a way that the valve outlet points away from oxygen cylinder.
- xiii) Acetylene cylinder key for opening valve shall be kept on valve stem, while cylinder is in use, so that the acetylene cylinder could be quickly turned off in case of emergency. Use flash back arrestors to prevent back-fire in acetylene/oxygen cylinder.
- xiv) When not in use, valves of all cylinders shall be kept closed.
- xv) All types of cylinders, whether full or empty, shall be stored at cool, dry place under shed.
- xvi) Forced opening of any cylinder valve should not be attempted.
- xvii) Lighted gas torch shall never be left unattended.
- xviii) Store acetylene and oxygen cylinders separately.

Place
Date

Signature of the Bidder
(NAME & ADDRESS WITH SEAL)



BHARAT HEAVY ELECTRICALS LIMITED

POWER PLANT PIPING UNIT

THIRUMAYAM- 622 507

CONTRACTS DEPARTMENT

Phone : 04333279551

E.mail : ilango@bheltry.co.in Website : www.bhel.com

Tender No:PPPU:WC:14:015

Tender Notice

Dt. 04.10.2014

- xix) Store full and empty cylinders separately.
- xx) Avoid cylinders coming into contact with heat.
- xxi) Cylinders that are heavy or difficult to carry by hand may be rolled on their bottom edge but never dragged.
- xxii) If cylinders have to be moved, be sure that the cylinder valves are shut off.
- xxiii) Before changing torches, shut off the gas at the pressure reducing regulators and not by crimping the hose.
- xxiv) Do not use matches to light torches, use a friction lighter.
- xxv) Move out any leaking cylinder immediately.
- xxvi) Use trolleys for oxygen & acetylene cylinder and chain them.
- xxvii) Always use Red hose for acetylene and other fuel gases and Black for oxygen, and ensure that both are in equal length.
- xxviii) Ensure that hoses are free from burns, cuts and cracks and properly clamped.
- xxix) Avoid dragging hoses over sharp edges and objects
- xxx) Do not wrap hoses around cylinders when in use or stored.
- xxxi) Protect hoses from flying sparks, hot slag, and other hot objects.
- xxxii) Lubricants shall not be used on Ox-fuel gas equipment.
- xxxiii) During cutting/welding, use proper type goggles/face shields.

6.6 WORKING IN CONFINED SPACES

- 6.6.1 Following safety practices for working in confined space like towers, columns, tanks and cellars should be followed in addition to the safety guidelines for specific jobs like scaffolding, cutting/welding etc.
- i) Entry inside the confined area and to carry out any job should be done after issuance of valid permit only, in line with form 310-017.
 - ii) Ensure proper and accessible means of exit before entry inside a confined space.
 - iii) The number of persons allowed inside the area should be limited to avoid overcrowding.
 - iv) When the work is going on in the confined space, there should always be one man standby at the nearby man way.
 - v) Before entering inside the area - underground or located at lower elevation, probability of dense vapours accumulating nearby should also be considered in addition to inside the vessel.

Place
Date

Signature of the Bidder
(NAME & ADDRESS WITH SEAL)



BHARAT HEAVY ELECTRICALS LIMITED

POWER PLANT PIPING UNIT

THIRUMAYAM- 622 507

CONTRACTS DEPARTMENT

Phone : 04333279551

E.mail : ilango@bheltry.co.in Website : www.bhel.com

Tender No:PPPU:WC:14:015

Tender Notice

Dt. 04.10.2014

- vi) Ensure requisite O₂ level before entry in the confined space and monitor level periodically or other wise use respiratory devices.
- vii) Check for no Hydrocarbon or toxic substances before entry and monitor level periodically or use requisite Personal Protective Equipment.
- viii) Ensure adequate ventilation or use respiratory devices.
- ix) Depending upon need, necessary respirator system, gas masks and suit shall be worn by everyone entering confined space. In case of sewer, manholes or in the confined area where there is a possibility of toxic or inert gas, gas masks shall be used by everyone while entering.
- x) Barricade the confined spaces
- xi) Use 24V flameproof lamp fittings only for illumination.
- xii) Use tools with air motors or electric tools with maximum voltage of 24V.
- xiii) House keeping shall be well maintained.
- xiv) Safety helmet, safety shoes and safety belt shall be worn by everyone entering the confined space.
- xv) Don't wear loose clothing while working in a confined space.
- xvi) The gas cylinders used for cutting/welding shall be kept outside.
- xvii) All cables, hoses, welding equipment etc., shall be removed from confined space at end of each work day, even if the work is to be resumed in the same space the next day.
- xviii) To the extent possible sludge shall be cleared and removed from outside before entering.
- xix) No naked light or flame or hot work such as welding, cutting and soldering should be permitted inside a confined space or area unless it has been made completely free of the flammable atmosphere, tested and found safe by a competent person. Only non-sparking tools and flameproof hand lamps protected with guard and safety torches should be used inside such confined space or area for initial inspection, cleaning or other work required to be done for making the area safe.
- xx) Communication should be always maintained between the worker and the attendant.

6.7 WORKING AT HEIGHTS

6.7.1 General Provision

- i) While working at a height of more than 2 meters, ISI approved safety belt shall be used.
- ii) While working at a height of more than 2 meters, permit should be issued by competent person in form 310-015, before commencement of the job.
- iii) Worker should be well trained on usage of safety belt including its proper usage at the time of ascending/descending.
- iv) All tools should be carried in tool kits to avoid their falling.

Place
Date

Signature of the Bidder
(NAME & ADDRESS WITH SEAL)



BHARAT HEAVY ELECTRICALS LIMITED

POWER PLANT PIPING UNIT

THIRUMAYAM- 622 507

CONTRACTS DEPARTMENT

Phone : 04333279551

E.mail : ilango@bheltry.co.in Website : www.bhel.com

Tender No:PPPU:WC:14:015

Tender Notice

Dt. 04.10.2014

- v) If the job is on fragile/sloping roof, roof walk ladders shall be used, in addition to getting safe work permit in form 310-012.
- vi) Provide lifeline wherever required.
- vii) Additional safety measures like providing Fall Arrestor type Safety belt, safety net should be provided depending upon site conditions, job requirements.
- viii) Keep working area neat and clean. Remove scrap material immediately.
- ix) Don't throw or drop material/equipment from height.
- x) Avoid jumping from one member to another. Use proper passageway.
- xi) Keep both hands free while climbing. Don't try to bypass the steps of the ladder.
- xii) Try to maintain calm at height. Avoid over exertion.
- xiii) Avoid movements on beam.
- xiv) Elevated workplaces including roofs should be provided with safe means of access and egress such as stairs, ramps or ladders.

6.7.2 Roof Work

- i) All roof-work operations should be pre-planned and properly supervised.
- ii) Roof work should only be undertaken by workers who are physically and psychologically fit and have the necessary knowledge and experience for such work.
- iii) Work on roofs shouldn't be carried on in weather conditions that threaten the safety of workers.
- iv) Crawling boards, walkways and roof ladders should be securely fastened to a firm structure.
- v) Roofing brackets should fit the slope of the roof and be securely supported.
- vi) Where it is necessary for a person to kneel or crouch near the edge of the roof, necessary precautions should be taken.
- vii) On a large roof where work have to be carried out at or near the edge, a simple barrier consisting of crossed scaffold tubes supporting a tubing guardrail may be provided.
- viii) All covers for openings in roofs should be of substantial construction and be secured in position.
- ix) Roofs with a pitch of more than 10 should be treated as sloping.
- x) When work is being carried out on sloping roof, sufficient and suitable crawling boards or roof ladders should be provided and firmly secured in position.
- xi) During extensive work on the roof, strong barriers or guardrails and toe-boards should be provided to stop a person from falling off the roof.
- xii) Where workers are required to work on or near roof or other places covered with fragile material, through which they are liable to fall, they should be provided with suitable roof

Place
Date

Signature of the Bidder
(NAME & ADDRESS WITH SEAL)



BHARAT HEAVY ELECTRICALS LIMITED

POWER PLANT PIPING UNIT

THIRUMAYAM- 622 507

CONTRACTS DEPARTMENT

Phone : 04333279551

E.mail : ilango@bheltry.co.in Website : www.bhel.com

Tender No:PPPU:WC:14:015

Tender Notice

Dt. 04.10.2014

ladders or crawling boards strong enough and when spanning across the supports for the roof covering to support those workers.

- xiii) A minimum of two boards should be provided so that it is not necessary for a person to stand on a fragile roof to move a board or a ladder, or for any other reason.

6.8 HANDLING AND LIFTING EQUIPMENT:

6.8.1 General Provisions

Following are the general guidelines to be followed with regard to all types of handling and lifting equipment in addition to the guidelines for specific type of equipments dealt later on.

- i) There should be a well-planned safety programme to ensure that all the lifting appliances and lifting gear are selected, installed, examined, tested, maintained, operated and dismantled with a view to preventing the occurrence of any accident;
- ii) All lifting appliances shall be examined by competent persons at frequencies as specified in "The Factory act".
- iii) Check thoroughly quality, size and condition of all lifting tools like chain pulley blocks, slings, U-clamps, D-shackles etc. before putting them in use.
- iv) Safe lifting capacity of all lifting & handling equipment, tools and shackles should be got verified and certificates obtained from competent authorities before its use. The safe working load shall be marked on them.
- v) Check periodically the oil, brakes, gears, horns and tyre pressure of all moving equipments like cranes, forklifts, trailers etc as per manufacturer's recommendations.
- vi) Check the weights to be lifted and accordingly decide about the crane capacity, boom length and angle of erection.
- vii) Allow lifting slings as short as possible and check packing at the friction points.
- viii) While lifting/placing of the load, no unauthorised person shall remain within the radius of the boom and underneath the load.
- ix) While loading, unloading and stacking of pipes, proper wedges shall be placed to prevent rolling down of the pipes.
- x) Control longer jobs being lifted up from both ends.
- xi) Only trained operators and riggers should carry out the job. While the crane is moving or lifting the load, the trained rigger should be there for keeping a vigil against hitting any other object.
- xii) During high wind conditions and nights, lifting of heavy equipments should be avoided. If unavoidable to do erection in night, operator and rigger should be fully trained for night signaling. Also proper illumination should be there.
- xiii) Allow crane to move on hard, firm and leveled ground.

Place
Date

Signature of the Bidder
(NAME & ADDRESS WITH SEAL)



BHARAT HEAVY ELECTRICALS LIMITED

POWER PLANT PIPING UNIT

THIRUMAYAM- 622 507

CONTRACTS DEPARTMENT

Phone : 04333279551

E.mail : ilango@bheltry.co.in Website : www.bhel.com

Tender No:PPPU:WC:14:015

Tender Notice

Dt. 04.10.2014

- xiv) When crane is in idle condition for long periods or unattended, crane boom should either be lowered or locked as per manufacturer's guidelines.
- xv) Hook and load being lifted shall remain in full visibility of crane operators, while lifting, to the extent possible.
- xvi) Don't allow booms or other parts of crane to come within 3 meters reach of overhead electrical cables.
- xvii) No structural alterations or repairs should be made to any part of a lifting appliance, which may affect the safety of the appliance without the permission and supervision of the competent person.

6.8.2 Hoists

- i) Hoist shafts should be enclosed with rigid panels or other adequate fencing at:
 - (a) ground level on all sides;
 - (b) all other levels at all points at which access is provided;
 - (c) all points at which persons are liable to be struck by any moving part.
- ii) The enclosure of hoist shafts, except at approaches should extend where practicable at least 2mt above the floor, platform or other place to which access is provided except where a lesser height is sufficient to prevent any person falling down the hoist way and there is no risk of any person coming into contact with any moving part of the hoist, but in no case should the enclosure be less than 1mt in height.
- iii) The guides of hoist platforms should offer sufficient resistance to bending and, in the case of jamming by a safety catch, to buckling.
- iv) Where necessary to prevent danger, adequate covering should be provided above the top of hoist shafts to prevent material falling down them.
- v) Outdoor hoist towers should be erected on firm foundations, and securely braced, guyed and anchored.
- vi) A ladder way should extend from the bottom to the top of outdoor hoist towers, if no other ladder way exists within easy reach.
- vii) Hoisting engines should be of ample capacity to control the heaviest load that they will have to move.
- viii) Hoists should be provided with devices that stop the hoisting engine as soon as the platform reaches its highest stopping place.
- ix) Winches should be so constructed that the brake is applied when the control handle is not held in the operating position.
- x) It should not be possible to set in motion from the platform a hoist, which is not designed for the conveyance of persons.

Place
Date

Signature of the Bidder
(NAME & ADDRESS WITH SEAL)



BHARAT HEAVY ELECTRICALS LIMITED

POWER PLANT PIPING UNIT

THIRUMAYAM- 622 507

CONTRACTS DEPARTMENT

Phone : 04333279551

E.mail : ilango@bheltry.co.in Website : www.bhel.com

Tender No:PPPU:WC:14:015

Tender Notice

Dt. 04.10.2014

- xi) Winches should not be fitted with pawl and ratchet gears on which the pawl must be disengaged before the platform is lowered.
- xii) Hoist platforms should be capable of supporting the maximum load that they will have to carry with a safety factor.
- xiii) Hoist platforms should be equipped with safety gear that will hold the platform with the maximum load if the hoisting rope breaks.
- xiv) If workers have to enter the cage or go on the platform at landings there should be a locking arrangement preventing the cage or platform from moving while any worker is in or on it.
- xv) On sides not used for loading and unloading, hoist platforms should be provided with toe-boards and enclosures of wire mesh or other suitable material to prevent the fall of parts of loads.
- xvi) Where necessary to prevent danger from falling objects, hoist platforms should be provided with adequate covering.
- xvii) Counterweights consisting of an assemblage of several parts should be made of specially constructed parts rigidly connected together.
- xviii) Counterweights should run in guides.
- xix) Platforms should be provided at all landings used by workers.
- xx) Following notices should be posted up conspicuously and in very legible characters:
 - (a) on all hoists:
 - on the platform: the carrying capacity in kilograms or other appropriate standard unit of weight;
 - on the hoisting engine: the lifting capacity in kilograms or other appropriate standard unit of weight;
 - (b) on hoists authorised or certified for the conveyance of persons:
 - on the platform or cage: the maximum number of persons to be carried at one time;
 - (c) on hoists for goods only:
 - on every approach to the hoist and on the platform: prohibition of use by persons.
- xxi) Hoists intended for the carriage of persons should be provided with a cage so constructed as to prevent any person from falling out or being trapped between the cage and any fixed part of the structure when the cage gate is shut, or from being struck by the counterbalance weight or by articles or materials trailing down the hoist way.
- xxii) On each side in which access is provided, the cage should have a gate fitted with devices which ensure that the gate cannot be opened except when the cage is at a landing and that the gate must be closed before the cage can move away from the landing.

Place
Date

Signature of the Bidder
(NAME & ADDRESS WITH SEAL)



BHARAT HEAVY ELECTRICALS LIMITED

POWER PLANT PIPING UNIT

THIRUMAYAM- 622 507

CONTRACTS DEPARTMENT

Phone : 04333279551

E.mail : ilango@bheltry.co.in Website : www.bhel.com

Tender No:PPPU:WC:14:015

Tender Notice

Dt. 04.10.2014

- xxiii) Every gate in the enclosure of the hoist shaft which gives access from a landing place to the cage should be fitted with devices to ensure that the gate cannot be opened except when the cage is at that landing place, and that the cage cannot be moved away from that landing place until the gate is closed.

6.8.3 Derricks

Stiff-leg derricks

- i) Derricks should be erected on a firm base capable of taking the combined weight of the crane structure and maximum rated load.
- ii) Devices should be used to prevent masts from lifting out of their seating.
- iii) Electrically operated derricks should be effectively earthed from the sole plate or framework.
- iv) Counterweights should be so arranged that they do not subject the backstays, sleepers or pivots to excessive strain.
- v) When derricks are mounted on wheels:
 - a) a rigid member should be used to maintain the correct distance between the wheels;
 - b) they should be equipped with struts to prevent them from dropping if a wheel breaks or the derrick is derailed.
- vi) The length of a derrick jib should not be altered without consulting the manufacturer.

Guy derricks

- i) The restraint of the guy ropes should be ensured by fitting stirrups or anchor plates in concrete foundations.
- ii) The mast of guy derricks should be supported by six top guys spaced approximately equally.
- iii) The spread of the guys of a guy derrick crane from the mast should not be more than 45° from the horizontal.
- iv) Guy ropes of derricks should be equipped with a stretching screw or turnbuckle or other device to regulate the tension.
- v) Gudgeon pins, sheave pins and fool bearings should be lubricated frequently.
- vi) When a derrick is not in use, the boom should be anchored to prevent it from swinging.

6.8.4 Lifting ropes

- i) Only ropes with a known safe working capacity should be used as lifting ropes.
- ii) Lifting ropes should be installed, maintained and inspected in accordance with manufacturers' instructions.
- iii) Repaired steel ropes should not be used on hoists.

Place
Date

Signature of the Bidder
(NAME & ADDRESS WITH SEAL)



BHARAT HEAVY ELECTRICALS LIMITED

POWER PLANT PIPING UNIT

THIRUMAYAM- 622 507

CONTRACTS DEPARTMENT

Phone : 04333279551

E.mail : ilango@bheltry.co.in Website : www.bhel.com

Tender No:PPPU:WC:14:015

Tender Notice

Dt. 04.10.2014

- iv) Where multiple independent ropes are used, for the purpose of stability, to lift a work platform, each rope should be capable of carrying the load independently.

6.9 VEHICLE MOVEMENT

- 6.9.1 Park vehicles only at designated places. Don't block roads to create hindrance for other vehicles.
- 6.9.2 Don't overload the vehicle.
- 6.9.3 Obey speed limits and traffic rules.
- 6.9.4 Always expect the unexpected and be a defensive driver.
- 6.9.5 Drive carefully during adverse weather and road conditions.
- 6.9.6 Read the road ahead and ride to the left.
- 6.9.7 Be extra cautious at nights. Keep wind screens clean and lights in working condition.
- 6.9.8 All vehicles used for carrying workers and construction materials must undergo predictive/preventive maintenance and daily checks
- 6.9.9 Driver with proper valid driving license shall only be allowed to drive the vehicle
- 6.9.10 Routes shall be leveled, marked and planned in such a way so as to avoid potential hazards such as overhead power lines and sloping ground etc.
- 6.9.11 While reversing the vehicles, help of another worker should be ensured at all times
- 6.9.12 An unattended vehicle should have the engine switched off
- 6.9.13 Wherever possible one-way system shall be followed
- 6.9.14 Barriers/fixed stops should be provided for excavation/openings to prevent fall of vehicle
- 6.9.15 Load should be properly secured
- 6.9.16 The body of the tipper lorry should always be lowered before driving the vehicle off.
- 6.9.17 Signs/signals/caution boards etc. should be provided on routes .

6.10 DEMOLITION

6.10.1. General provisions

- i) When the demolition of any building or structure might present danger to workers or to the public:
- (a) necessary precautions, methods and procedures should be adopted, including those for the disposal of waste or residues;
- (b) the work should be planned and undertaken only under the supervision of a competent person.
- ii) Before demolition operations begin:
- (a) structural details and builders' drawings should be obtained wherever possible;

Place
Date

Signature of the Bidder
(NAME & ADDRESS WITH SEAL)



BHARAT HEAVY ELECTRICALS LIMITED

POWER PLANT PIPING UNIT

THIRUMAYAM- 622 507

CONTRACTS DEPARTMENT

Phone : 04333279551

E.mail : ilango@bheltry.co.in Website : www.bhel.com

Tender No:PPPU:WC:14:015

Tender Notice

Dt. 04.10.2014

- (b) details of the previous use should be obtained to identify any possible contamination and hazards from chemicals, flammables, etc.;
 - (c) an initial survey should be carried out to identify any structural problems and risks associated with flammable substances and substances hazardous to health.
The survey should note the type of ground on which the structure is erected, the condition of the roof trusses, the type of framing used in framed structures and the load-bearing walls;
 - (d) a method of demolition should be formulated after the survey and recorded in a method statement having taken all the various considerations into account and identifying the problems and their solutions;
- iii) All electric, gas, water and steam service lines should be shut off and, as necessary, capped or otherwise controlled at or outside the construction site before work commences.
 - iv) If it is necessary to maintain any electric power, water or other services during demolition operations, they should be adequately protected against damage.
 - v) As far as practicable, the danger zone round the building should be adequately fenced off and sign posted. To protect the public a fence 2m high should be erected enclosing the demolition operations and the access gates should be secured outside working hours.
 - vi) The fabric of buildings contaminated with substances hazardous to health should be decontaminated. Protective clothing and respiratory devices should be provided and worn.
 - vii) Where plant has contained flammable materials, special precautions should be taken to avoid fire and explosion.
 - viii) The plant to be demolished should be isolated from all other plant that may contain flammable materials. Any residual flammable material in the plant should be rendered safe by cleaning, purging or the application of an inert atmosphere as appropriate.
 - ix) Care should be taken not to demolish any parts, which would destroy the stability of other parts.
 - x) Demolition activities should not be continued under adverse climatic conditions such as high winds, which could cause the collapse of already weakened structures.
 - xi) To prevent hazards parts of structures should be adequately shored, braced or otherwise supported.
 - xii) Structures should not be left in a condition in which they could be brought down by wind pressure or vibration.
 - xiii) Where a deliberate controlled collapse technique is to be used, expert engineering advice should be obtained, and:
 - (a) it should only be used where the whole structure is to come down because it relies on the removal of key structural members to effect a total collapse;
 - (b) it should only be used on sites that are fairly level and where there is enough surrounding space for all operatives and equipment to be withdrawn to a safe distance.

Place
Date

Signature of the Bidder
(NAME & ADDRESS WITH SEAL)



BHARAT HEAVY ELECTRICALS LIMITED

POWER PLANT PIPING UNIT

THIRUMAYAM- 622 507

CONTRACTS DEPARTMENT

Phone : 04333279551

E.mail : ilango@bheltry.co.in Website : www.bhel.com

Tender No:PPPU:WC:14:015

Tender Notice

Dt. 04.10.2014

- xiv) When equipment such as power shovels and bulldozers are used for demolition, due consideration should be given to the nature of the building or structure, its dimensions, as well as to the power of the equipment being used.
- xv) If a swinging weight is used for demolition, a safety zone having a width of at least one-and-a-half times the height of the building or structure should be maintained around the points of impact.

6.10.2. Demolition of structural steelwork

- i) All precautions should be taken to prevent danger from any sudden twist, spring or collapse of steelwork, ironwork or reinforced concrete when it is cut or released.
- ii) Steel construction should be demolished tier by tier.
- iii) Structural steel parts should be lowered and not dropped from a height.

6.11 MASONRY WORKS

- i) Ensure proper stacking of bricks as per standard practice.
- ii) Ensure stability of scaffold and working platform before commencing the work.
- iii) Ensure usage of relevant PPE like safety belt etc
- iv) Ensure mortar mixing, platform sufficiently away from the work spot.
- v) Do not raise more than the stipulated height at a time.
- vi) Permit further raising of structure only after adequate curing.
- vii) Remove unused materials and debris from work spot immediately after the completion of work.

7.0 FIRST AID

First aid facilities should be provided in line with various statutory regulations like factory act etc. However following care should be taken:

- i) First aid, including the provision of trained personnel should be ensured at work sites. Arrangement should be made for ensuring the medical attention of the injured workers. First aid box should be as per the Factory rules.
- ii) Suitable rescue equipment, like stretchers should be kept readily available at the construction site.
- iii) First-aid kits or boxes, as appropriate and as per statutory requirements, should be provided at workplaces and be protected against contamination by dust, moisture etc.
- iv) First-aid kit or boxes should not keep anything besides material for first aid in emergencies.

Place
Date

Signature of the Bidder
(NAME & ADDRESS WITH SEAL)



BHARAT HEAVY ELECTRICALS LIMITED

POWER PLANT PIPING UNIT

THIRUMAYAM- 622 507

CONTRACTS DEPARTMENT

Phone : 04333279551

E.mail : ilango@bheltry.co.in Website : www.bhel.com

Tender No:PPPU:WC:14:015

Tender Notice

Dt. 04.10.2014

- v) First-aid kits and boxes should contain simple and clear instructions to be followed, be kept under the charge of a responsible person qualified to render the first aid and be regularly inspected and stocked.
- vi) Emergency telephone numbers of nearby Hospitals, Police, Fire Station and Administration should be prominently displayed.

8.0 DOCUMENTATION

The intention of keeping documentation of all types of accident(s) is to prevent recurrence of similar accident(s). All accidents should be reported as per Guidelines and Factories Act, 1948.

All accidents (major, minor or near miss) should be investigated, analyzed and recommendations should be documented along with implementation status.

All related data should be well-documented and further analysis highlighting the major cause(s) of accidents be done. This will help in identifying thrust areas and training needs for prevention of accidents.

9.0 SAFETY AWARENESS & TRAINING

Safety awareness to all section of personnel ranging from site-in-charge to workmen helps not only preventing the risk but also build up the confidence. Time and expenditures also get saved as a result.

Safety awareness basically seeks to persuade/inform people on safety besides supplementing skill also. Awareness programme may include followings:

- i) **Poster:** Posters with safety slogan in humorous, gruesome demonstrating manner may be used to discourage bad habits attributable to accidents by appealing to the workers' pride, self-love, affection curiosity or human aspects. These should be displayed in prominent location(s).
- ii) **Safety Sign Boards:** Different type of message of cautioning, attention, notice etc. should be displayed at the appropriate places for learning/ awareness of the workmen while working at site.
- iii) **Films & Slides:** Film(s) narrating the accident including the causes and possible remedial ways of preventing the recurrence of a similar accident should be displayed at regular intervals. Slides consisting main points of the film show may also be shown to workers.
- iv) **Talks, lectures & conferences:** The success of these events would depend much on audience's understandings of the speaker (s). The speakers are to be knowledgeable and good presenter. Speakers should know to hold the attention and to influence the audiences.

Place
Date

Signature of the Bidder
(NAME & ADDRESS WITH SEAL)



BHARAT HEAVY ELECTRICALS LIMITED

POWER PLANT PIPING UNIT

THIRUMAYAM- 622 507

CONTRACTS DEPARTMENT

Phone : 04333279551

E.mail : ilango@bheltry.co.in Website : www.bhel.com

Tender No:PPPU:WC:14:015

Tender Notice

Dt. 04.10.2014

- v) **Compositions:** Organize competition(s) between the different depts./categories of workers. The sense of reward/recognition also will improve safety awareness and result in enhancing safety levels.
- vi) **Exhibitions:** Exhibitions also make the workers acquainted with hazards and means of preventive measures.
- vii) **Safety Publication:** Safety publications including pocket books dealing with ways of investigation and prevention in the field of safety and so on, may be distributed to workers to promote the safety awareness.
- viii) **Safety Drives:** From time to time, an intensive safety drive by organizing a safety day or a safety week etc. should be launched.
- ix) **Training:** Training for covering the hazards for different trade should be imparted. Training should also include the specific hazards related to a job in addition to the general safety training as has been dealt in various chapters and should include all workers.

Place
Date

Signature of the Bidder
(NAME & ADDRESS WITH SEAL)



BHARAT HEAVY ELECTRICALS LIMITED

POWER PLANT PIPING UNIT

THIRUMAYAM- 622 507

CONTRACTS DEPARTMENT

Phone : 04333279551

E.mail : ilango@bheltry.co.in Website : www.bhel.com

Tender No:PPPU:WC:14:015

Tender Notice

Dt. 04.10.2014

10.0 LIST OF SAFETY CODES FOR CIVIL WORKS PUBLISHED BY BUREAU OF

INDIAN STANDARDS

Sl.No.	Code No.	Title
01	IS : 818	Code of Practice for Safety and Health Requirements in Electric and Gas Welding and Cutting Operations – First Revision.
02	IS : 875	Code of practice for Structural safety of buildings: Masonry walls
03	IS : 933	Specification for Portable Chemical Fire Extinguisher, Foam Type – Second Revision.
04	IS :1179	Specification for Equipment for Eye and Face Protection during Welding – First Revision.
05	IS : 1904	Code of practice for Structural safety of buildings: Shallow foundations
06	IS : 1905	Code of practice for Structural safety of buildings: Masonry walls
07	IS : 2171	Specification for Portable Fire Extinguishers, Dry Powder Type –Second Revision.
08	IS : 2361	Specification for Building Grips – First Revision.
09	IS : 2750	Specification for Steel Scaffoldings.
10	IS : 2925	Specification for Industrial Safety Helmets – First Revision
11	IS : 3016	Code of Practice for Fires Precautions in Welding and Cutting Operations – First Revision
12	IS : 3521	Industrial safety belts and harnesses
13	IS : 3696	Safety Code for Scaffoldings and Ladders : Part I – Scaffoldings.

Place
Date

Signature of the Bidder
(NAME & ADDRESS WITH SEAL)



BHARAT HEAVY ELECTRICALS LIMITED

POWER PLANT PIPING UNIT

THIRUMAYAM- 622 507

CONTRACTS DEPARTMENT

Phone : 04333279551

E.mail : ilango@bheltry.co.in Website : www.bhel.com

Tender No:PPPU:WC:14:015

Tender Notice

Dt. 04.10.2014

14	IS : 3696	Safety Code for Scaffolds and Ladders : Part II – Ladders.
15	IS : 3764	Safety Code for Excavation Work
16	IS : 4014	Part I & II Code of practice for Steel tubular scaffolding
17	IS : 4081	Safety Code for Blasting and Related Drilling Operations.
18	IS : 4082	Recommendations on staking and storage of construction materials at site

Sl.No.	Code No.	Title
19	IS : 4130	Safety Code for Demolition of Buildings – First Revision.
20	IS : 4138	Safety Code Working in Compressed Air-First Revision
21	IS : 4912	Safety requirements for Floor and Wall Openings, Railings and toe Boards –First Revision.
22	IS : 5121	Safety Code for Piling and other Deep Foundations.
23	IS : 5916	Safety Code for Construction involving use of Hot Bituminous Materials.
24	IS : 5983	Specification for Eye Protectors – First Revision.
25	IS : 6922	Structures subject to underground blasts, criteria for safety and design
26	IS : 7205	Safety Code for Erection on Structural Steel Works.
27	IS : 7069	Safety Code for Handling and Storage of Building Materials.
28	IS :7293	Safety Code for Working with Construction Machinery.
29	IS : 7969	Safety code for handling and storage of building material
30	IS : 8758	Recommendation for Fire Precautionary Measures in construction of Temporary Structures and Pandals.

Place
Date

Signature of the Bidder
(NAME &ADDRESS WITH SEAL)



BHARAT HEAVY ELECTRICALS LIMITED

POWER PLANT PIPING UNIT

THIRUMAYAM- 622 507

CONTRACTS DEPARTMENT

Phone : 04333279551

E.mail : ilango@bheltry.co.in Website : www.bhel.com

Tender No:PPPU:WC:14:015

Tender Notice

Dt. 04.10.2014

31	IS : 8989	Safety Code for Erection of Concrete Framed Structures
32	IS : 9759	Guidelines for de-watering during construction
33	IS : 11057	Code of practice for Industrial safety nets
34	IS : 13415	Code of Practice on safety for Protective barriers in and around building
35	IS : 13416	Recommendations for preventive measures against hazards at working places

Place
Date

Signature of the Bidder
(NAME & ADDRESS WITH SEAL)



BHARAT HEAVY ELECTRICALS LIMITED

POWER PLANT PIPING UNIT

THIRUMAYAM- 622 507

CONTRACTS DEPARTMENT

Phone : 04333279551

E.mail : ilango@bheltry.co.in Website : www.bhel.com

Tender No:PPPU:WC:14:015

Tender Notice

Dt. 04.10.2014

GENERAL AND SPECIAL SPECIFICATIONS

BHEL APPROVED BRANDS FOR THE FOLLOWING MATERIALS / ITEMS

Sl.No.	Material	Manufacturing Co.	Brand
1.	Synthetic Enamel Paint	Asian Berger ICI	Apolite Luxol Dulux gloss
2.	Aluminium Paint	Berger	Berger Aluminium
3.	Interior Emulsion	Asian Berger ICI	Royale Luxol Silk Supercote
4.	Exterior Emulsion	Asian ICI	ACE Supercote
5.	Distemper	Asian Berger ICI	Tractor Bison Maxilite
6.	Cement Paint	Snowcem Agsarcem	Snowcem Agsarcem
7.	A.C. Sheets	Everest India Ltd. Hyderabad India Ltd. Visaka Industries Ltd. Ramco	Everest I Charminar Visaka Ramco
8.	G.I. Pipes	TATA Zenith TNT	TATA Zenith TNT
9.	PVC Pipes	Avonplast Finolex Truebore Vignesh	Avonplast Finolex Truebore Vignesh

Place
Date

Signature of the Bidder
(NAME & ADDRESS WITH SEAL)



BHARAT HEAVY ELECTRICALS LIMITED

POWER PLANT PIPING UNIT

THIRUMAYAM- 622 507

CONTRACTS DEPARTMENT

Phone : 04333279551

E.mail : ilango@bheltry.co.in Website : www.bhel.com

Tender No:PPPU:WC:14:015

Tender Notice

Dt. 04.10.2014

1. Site Clearance

All the area upon which the construction is to be carried out and areas which are required by the Contractor for his construction facilities are to be cleared off all rubbish and objectionable matter at Contractor's own cost. Trees, if any, shall not be uprooted or cut without the prior approval of the Engineer-in-charge. All spoils, unserviceable materials and rubbish shall be burnt or removed from site. Usable materials, saleable timber, fire-wood etc., shall be stocked properly at work site in the manner as directed by the Engineer-in-charge. The cost of clearing the areas shall be deemed to have been included by the tenderer in his general rate.

2. Earthwork for Foundations

Earthwork excavation for foundations and filling in foundations shall conform to TNBP 23 and 24. The area to be excavated or filled in with excavated materials shall be clearly demarcated in the field by the Contractor. Excavation shall be done to lines and levels defined. Excavation shall be carried out to such widths, lengths, depths, profiles and grades as shown in the drawing or as may be specified by the Engineer – in – charge. Rough Excavation may be carried out up to a depth 15 cm less than the final level but the balance shall be excavated to precise level with special care. All soft pockets of soil met with even below the final level shall be removed and the excavation filled up as directed by Engineer-in-charge. The methods of excavation shall in every case be subject to the approval of the Engineer-in-charge and the contractor shall ensure the safety and stability of the excavations, being executed by him as well adjacent buildings, structures, services and other works in the vicinity of the site of work. Wherever necessary Engineer-in-charge may direct that the sides of the excavation should be timbered and shored at the contractor's own cost, adopting a proper method approved by the Engineer-in-charge. Notwithstanding the above, should any slip occur, the contractor shall remove all the slipped materials from the excavated pit, at his own cost. He shall also make good at his own all damages caused to the work as well as adjacent buildings, structures etc., as a result of the slip, referred to.

All excavation work shall be subject to inspection and approved by the Engineer-in-charge before any further works in the excavated areas allowed to commence. Should any excavation be carried out beyond the specified depth, the contractor should fill it up at his own cost with the same type and class of material as it is proposed to be laid over the excavated portion. No payment will however be made to the contractor on his account.

The contractor shall ensure that the excavations and the structures under construction are kept free from water logging at all stages of construction. He shall take all necessary precautions and `streams, aquifers, springs, surface flows etc., are excluded effectively so as to ensure that the works are carried out in a reasonable dry conditions in accordance with the construction schedule.

Back filling around the foundations, trenches, plinth and under the floor shall be done in accordance with TNBP 24 and 25. The finished level of the plinth filling shall be trimmed to the slope required to be given to the finished floor. Back filling, watering and consolidation of excavated earth in layers

Place
Date

Signature of the Bidder
(NAME & ADDRESS WITH SEAL)



BHARAT HEAVY ELECTRICALS LIMITED

POWER PLANT PIPING UNIT

THIRUMAYAM- 622 507

CONTRACTS DEPARTMENT

Phone : 04333279551

E.mail : ilango@bheltry.co.in Website : www.bhel.com

Tender No:PPPU:WC:14:015

Tender Notice

Dt. 04.10.2014

etc., complete as per specifications shall be done unless otherwise stipulated in the tender schedule.

Removal of Hard rock by Blasting

This shall include all rock occurring in large masses which cannot be removed except by blasting. Blasting shall be done in conformity with TNBP 19 & 23 and as instructed by the Engineer-in-charge. When rock blasting has to be done adjacent to structures, the following precautions shall be observed.

1. All blasting should be completely muffled to prevent damage by flying pieces.
2. Blasting within 3 meters of the structures shall be avoided
3. No blasting should be done within 1.5 meters of concrete / masonry structures.
4. An isolated boulder extending under the existing structure but projecting within the area of blasting should be blasted.
5. The contractor shall be responsible for all damages caused by blasting and shall replace or repair the damaged structures at his own cost.

3. Plain and Reinforced Cement Concrete Works :

All design and construction shall be performed in accordance with the Indian standard code of Practice for plain and reinforced concrete – IS 456 and TNBP 30. Any Special requirements noted on the drawings or bill of quantities shall govern over the provisions of this specifications. Controlled concrete shall be used wherever specified in the schedule of items complying with all requirements of IS : 456 and as per special specifications appended herewith.

The coarse aggregate to be used shall be of hard broken granite stone jelly of various sizes as specified under respective items in the Bill of Quantities, conforming to IS 383 latest edition. The Engineer-in-charge may require the contractor to carryout moisture content tests in both fine and coarse aggregates. For determination of moisture content IS – 2386 shall be referred to. The amount of water to be added shall be then adjusted to compensate for any observed variation in the moisture contents. Proper control of mixing water is deemed of paramount importance. Mixtures with automatic water measuring drums shall be used or else. Water should be measured by volume in calibrated buckets. All measuring equipments shall be maintained in a clean serviceable condition and the accuracy periodically checked and got certified by the Engineer-in-charge. The contractor shall carryout slump tests apart from taking test cubes at regular intervals. All such methods of sampling and analysis of concrete shall be in accordance with IS – 1199.

Mixing of concrete shall be strictly carried out in an approved type mechanical mixer. The mixing equipment shall be capable of combining the aggregates, cement and water within the specified time (not less than 2 Minutes) into a thoroughly mixed and uniform mass and of discharging the mixture without segregation. Mixing shall be continued until there is a uniform colour and consistency, Concrete shall be handled from the place of mixing to the place of final deposit as rapidly as practicable by methods which will prevent segregation or loss of any of the ingredients.

Place
Date

Signature of the Bidder
(NAME & ADDRESS WITH SEAL)



BHARAT HEAVY ELECTRICALS LIMITED

POWER PLANT PIPING UNIT

THIRUMAYAM- 622 507

CONTRACTS DEPARTMENT

Phone : 04333279551

E.mail : ilango@bheltry.co.in Website : www.bhel.com

Tender No:PPPU:WC:14:015

Tender Notice

Dt. 04.10.2014

Before depositing the concrete, all debris and dirt shall be removed from the space to be occupied by concrete. Concreting shall not be done unless the formwork conform to the shapes, lines and dimension as shown in the drawings.

Unless otherwise approved, concrete shall be placed on single operation to the full thickness of slabs and beams and similar members and not exceeding 1 metre deep in walls, columns and similar members. Concrete shall be placed continuously until completion of the part of the work between construction joints or as directed by the Engineer-in-charge. The concrete after being laid shall be compacted by means of vibrators of approved type under proper supervision as directed by the Engineer-in-charge. Care should be taken to avoid segregation and formation of air bubbles. The whole process starting from the mixing of concrete to the placing and compaction shall not take more than 20 minute and the process shall be completed before the initial setting takes place. Curing shall be accomplished in accordance with IS-456 by keeping the concrete covered with a layer of sacking, canvas or similar absorbent materials and kept constantly wet for the period as directed by the Engineer-in-charge.

Reinforcement

All reinforcement shall be clean and free from pitting, loose mill-scales, dust, loose rust and coats of paint, oil or other coatings which may destroy or reduce bond. General construction details and workmanship relative to reinforcement including bar bends, lap splices and installation shall be in accordance with the IS-2502 as well as IS-456. All bars be bent as per the bar bending schedules indicated in the drawings or supplied separately relevant to particular drawing. The contractor shall in all cases verify himself the correctness of schedules, giving the number, length and the bending details of the bars. The numbers, sizes, shape and position of all the reinforcement shall, unless otherwise, directed or authorized by the Engineer-in-charge be strictly in accordance with the drawing. The reinforcement shall be adequately held in position by 18 / 20 SWG soft black annealed binding wire. The contractor must obtain the approval of Engineer-in-charge for the reinforcement placed, before any concrete is placed in the form. All reinforcing bars shall be so tied as to form a rigid cage to prevent displacement before or during concreting. Rate quoted for reinforcement should include cost of transporting M.S. Rods / CTD bars from BHEL Store to site of work, cleaning, cutting, bending, placing, binding with contractor's own binding wire and providing necessary cover blocks of concrete but excluding cost of steel which shall be supplied free of cost at BHEL Stores.

Form Work

Formwork shall conform to the shape, lines and dimensions of concrete and RCC structures as shown in the drawings and shall be well within the permissible tolerance. Formwork for concrete shall be of plywood, steel, good seasoned timber or other approved materials, properly designed easy for removal and cleaning. They shall be of sufficient strength and rigidity to maintain their position and shape under loads incidental to placing concrete. The number of props, their sizes and dispositions shall be such as to able safely carry the full dead load area constructional loads. The arrangement and alignment of formwork shall be got approved by the Engineer-in-charge prior to concreting. However this shall not relieve the contractor from his responsibility for proper work and safety. Formwork shall be sufficiently tight to prevent loss of cement slurry from the concrete. All joints and

Place
Date

Signature of the Bidder
(NAME & ADDRESS WITH SEAL)



BHARAT HEAVY ELECTRICALS LIMITED

POWER PLANT PIPING UNIT

THIRUMAYAM- 622 507

CONTRACTS DEPARTMENT

Phone : 04333279551

E.mail : ilango@bheltry.co.in Website : www.bhel.com

Tender No:PPPU:WC:14:015

Tender Notice

Dt. 04.10.2014

holes in the formwork shall be caulked with putty jute cloth or other approved materials to the satisfaction of the Engineer-in-charge. The stripping time for the shuttering and the formwork shall in general conform to the provisions in the relevant clauses of IS 456. Unless otherwise specified rates for reinforced cement concrete shall include cost of centering, shuttering charges also.

Expansion and Other Joints

Expansion Joints in concrete structures shall be provided at specified places as indicated in the drawings. The material shall be as specified by the Engineer-inc-charge, expansion joints, with or without metal strip shall be as shown on drawings the filler shall be “EXPANDEX JOINT FILLER” premoulded non – extrudent type fibrous joint filler impregnated with bitumen conforming to IS : 1838. The filler shall be durable, waterproof, compressible and shall have a high degree recovery after compression is released, ensuring thereby that no free space develops in the expansion joints. The top 25 mm, or as specified in the drawings, shall be sealed with “SHALITEX SEALING COMPOUND” or equivalent after application of approved primer.

4. Stone Masonry

General: Stone masonry shall conform to TNBP 35. Stone shall be obtained from the approved quarry and shall be free from decay and weathering.

All stones shall be thoroughly wetted before use. The mortar used for jointing shall be as specified under the respective items of the ‘Bill of Quantities’.

The walls shall be carried up truly plumb. Every stone shall be carefully fitted to the adjacent stones so as to form neat and closed joints.

To give sufficient lateral bond, vertical joints shall be avoided. Prescribed number of headers as required shall be provided to give sufficient transverse bond. At junctions of wall the stones each alternate course shall be so carried into each of the respective walls as to unite the work thoroughly. Where breaks are unavoidable in carrying up the work continuously in horizontal course sufficiently long steps shall be left to joint the old and new work building of two thin faces and filling up the middle with small stuff or dry packing shall be strictly avoided. When plastering or raised pointing is not required to be done joints shall be struck flush and finished simultaneously.

Coursed Rubble Masonry

Coursed rubble masonry shall conform to TNBP 35-H, I and J. Faces shall be accurately squared and all face joints shall be dressed at right angles. This bushing on the facing stones shall not project more than 38mm.

Face stones shall be laid alternate headers and stretchers. Depth of each course shall not be less than 150 mm. No course shall be greater than any course below. The height shall not exceed the

Place
Date

Signature of the Bidder
(NAME & ADDRESS WITH SEAL)



BHARAT HEAVY ELECTRICALS LIMITED

POWER PLANT PIPING UNIT

THIRUMAYAM- 622 507

CONTRACTS DEPARTMENT

Phone : 04333279551

E.mail : ilango@bheltry.co.in Website : www.bhel.com

Tender No:PPPU:WC:14:015

Tender Notice

Dt. 04.10.2014

breadth of stones of face. No stone shall tail into the wall less then its height. No pinning shall be allowed on the face. The stones shall be solidly bedded set full in mortar with joints not exceeding 12 mm in thickness.

Random rubble masonry

Random rubble masonry work shall conform to TNBP 35-L and J. Stones shall be hammer dressed at faces and joints to enable them to come into close proximity with each other. The face stone shall be laid headers and stretchers alternately, so as to break joint by at least 75mm. Thickness of joint shall not exceed 12mm. No pinning shall be used on the face and face stone shall extend well back into the headers. Stones less than 130 mm. in height shall not be used on the face.

Bond stones running through the wall shall be provided at 1.8M intervals in walls up to 0.60 M. thickness and if the wall is more than 0.60 M. thick a line of headers shall be laid from face to back each header overlapping the other by at least 150 mm.

5. Brick Masonry:

First class Bricks: Brick shall be sound, hard, tough, rectangular in shape and size, well burnt of uniform deep red or copper colour and conform to IS – 1077.

Brick shall be free from cracks, chips, flaws, stone or humps of any kind. Bricks shall be homogeneous in texture and emit a clear ringing sound on being struck and shall have a minimum compressive strength of 50KG / sq.cm. and shall not absorb water more than 20% of its weight, when soaked cold water for 24 Hrs. All bricks shall be table moulded.

Second Class Bricks: These shall be ground moulded but should otherwise conform to the specifications of first class bricks except for some surface cracks are allowable. These shall have minimum compressive strength of 50 Kg./sq.cm.

Samples of each type of brick, shall be got approved by the Engineer-in-charge before being used. All subsequent deliveries shall be up to the standards of the approved samples.

Brickwork shall conform to TNBP31 and IS –2212.

Brick works shall be classified as first or second class according to the classification of bricks used and the method of laying. The thickness of joints shall not exceed 6 mm. In first class brickwork and 10 mm in second class brick work.

Bricks shall be well soaked before use on works for at least 6 hrs. The soaked bricks shall be kept on wooden planks or platform. Brick required for masonry with clay or lime mortars shall not be soaked.

Brickwork shall be laid with specified mortar to be prepared in accordance with IS –2250. Brick works shall be laid in English Bond unless otherwise specified. Half or cut bricks shall not be used except

Place
Date

Signature of the Bidder
(NAME & ADDRESS WITH SEAL)



BHARAT HEAVY ELECTRICALS LIMITED

POWER PLANT PIPING UNIT

THIRUMAYAM- 622 507

CONTRACTS DEPARTMENT

Phone : 04333279551

E.mail : ilango@bheltry.co.in Website : www.bhel.com

Tender No:PPPU:WC:14:015

Tender Notice

Dt. 04.10.2014

when needed to complete the bond. Each course shall be taken up truly plumb, if battered, the batter is to be truly maintained. The level of brickwork shall be checked up at every one metre interval. Bricks shall be laid with frogs upward, while laying bricks shall be thoroughly bedded and flushed in mortar and taped into position with a wooden mallet and the superfluous mortar removed. Walls of all structures shall be carried up regularly in all cases, leaving no part, one metre lower than the other. Where the masonry of one part has to be delayed, the work shall be raked back according to bond (and not toothed) an angle not exceeding 45 Deg. But the raking back should not start within 60cm. of a corner vertical joints in alternate courses shall come directly over one another. The brickwork shall not be raised more than 14 courses per day. All iron fixtures, pipes, conduits, drains, sleeves, bolts, holdfasts of doors and windows etc. which are required to be built in walls shall be embedded in cement mortar or cement concrete as specified, in their correct position as the work proceeds.

Joints

Joints shall be restricted to 6 mm in first class brickwork and 10mm in second class brick work. All bed joints shall be normal to the pressure upon them, radial in arches and at right angles to the face in battered retaining walls. Care shall be taken that all joints are fully mortared (proportion as specified in the schedule items) well flushed up and in case where no pointing to be done, neatly struck at the work proceeds. The joints in faces which are to be plastered or pointed shall be squarely raked out to a depth of 12 mm while the mortar is still green. The raked joints shall be well brushed to remove loose particles. After the work the faces of work shall be cleared well by brush so as to remove any splashed mortar during the course of raising the brickwork.

Curing

Green work shall be protected from rain by suitable covering. Masonry work shall be kept thoroughly well watered on all faces for atleast 10 days after completion. In case of fat lime mortar curing shall commence two days after laying of masonry and shall continue for seven days.

6. Scaffolding

Scaffolding will generally be single but may be double if warranted for the particular work as approved by the Engineer-in-charge. The contractor shall take all measure to ensure safety of work and the working people.

Payment for brickwork shall be made on cubic metre basis on the volume of actual work done. Half brick wall and brick on edge wall shall be paid on square metre basis. The rate of brick work shall include scaffolding and all items mentioned above and no extra payment will be made for cutting bricks if required either for openings or for rounding or insertions or for recesses at the time of brick wall construction.

7. Damp Proof Course

Place
Date

Signature of the Bidder
(NAME & ADDRESS WITH SEAL)



BHARAT HEAVY ELECTRICALS LIMITED

POWER PLANT PIPING UNIT

THIRUMAYAM- 622 507

CONTRACTS DEPARTMENT

Phone : 04333279551

E.mail : ilango@bheltry.co.in Website : www.bhel.com

Tender No:PPPU:WC:14:015

Tender Notice

Dt. 04.10.2014

Damp proof course shall either be with cement concrete or with cement mortar of specified thickness as mentioned in the relevant item of schedule. Damp proof course shall not be carried across doorways. It shall be laid for all walls except verandah retaining wall or for particular wall only directed by the Engineer-in-charge. It shall be laid flush with floor level or as instructed by the Engineer-in-charge.

Damp proof course with cement concrete shall be of 25 or 38 mm thick in cement concrete M15/M20 as specified using 12mm. and down size aggregate well rammed and smoothed with trowel. It will be kept wet for 40 hours and after it has dried, two coats of hot bitumen shall be applied over it and allowed it to dry after which sand shall be sprinkled over it.

Damp proof course with cement mortar shall be 12 or 20 mm thick in cement mortar 1:3 well mixed with crude oil at 5% by weight of cement used.

8. Cement Plastering:

Cement plastering shall be in accordance with IS – 1661 and TNBP –56 & 57, Cement mortar shall conform to IS – 269. The mortar of specified mix and thickness shall be used.

The surface to be plastered shall be thoroughly cleaned so that it is free from dust, oil, salts etc., The joints of masonry shall be racked out to a depth of atleast 12 mm. On cement concrete surfaces the surface shall be cleaned with wire brush and scarified by lines with trowel or hacking done. The surfaces in both cases shall be washed properly and kept wet for 4 hours before plastering is commenced.

Plastering shall be started from top and gradually worked down towards the floor. It shall not at any place be thinner than specified. To ensure even thickness plaster of about 15 cm X 15 cm shall be first applied horizontally and vertically at not more than 2 metres intervals over the entire surface to serve as gauges. The surface of these gauges shall be truly in the plane of finished surface. The mortar shall then be laid in the wall or other surfaces between the gauges and finished even. All corners shall be rounded to a radius of 24 mm unless otherwise directed. The contractor shall not be paid for any extra thickness of plaster done than as specified.

Plaster, when more than 15 mm thick shall be applied in two coats, a base coat followed by the finishing coat. Thickness of the base coat shall be just sufficient to fill up unevenness in the surface, no single coat, however, shall exceed 12mm in thickness. The under coat shall be roughened or scratched before it is fully hardened.

Curing shall start 24 hours after the plaster is laid. It shall be kept wet for 14 days. During this period it shall be suitably protected from all damages at the contractor's cost by such means as approved by the Engineer-in-charge.

Any cracks which appear in the surface shall be cut out in rectangular shape and redone as directed by the Engineer-in-charge. Wherever specified standard waterproofing compound as approved by

Place
Date

Signature of the Bidder
(NAME & ADDRESS WITH SEAL)



BHARAT HEAVY ELECTRICALS LIMITED

POWER PLANT PIPING UNIT

THIRUMAYAM- 622 507

CONTRACTS DEPARTMENT

Phone : 04333279551

E.mail : ilango@bheltry.co.in Website : www.bhel.com

Tender No:PPPU:WC:14:015

Tender Notice

Dt. 04.10.2014

the Engineer-in-charge shall be added to the mortar at the rate of 2% or as specified by the manufacturer by the weight of cement for which the rate shall be paid separately. The rate for plastering shall include cost of scaffolding, swing etc., needed for the work with labour and material all complete.

9. Steel Door, Windows and Ventilators:

All steel doors, windows and ventilators shall conform to IS – 1038, IS – 1361 and IS 1081 or equivalent as mentioned in the bill of quantities and as approved by the Engineer-in-charge.

Rolled steel sections shall conform to Is – 226. The sections shall be cold straightened and finished goods shall be free from bends and other defects. Materials used in the fabrication shall be the best procurable and conforming to relevant IS specification. Thickness and specification of the glass to be provided shall be as indicated in the relevant item of the bill of quantities. Glass shall be free from flaws, specks, bubbles, etc., Bolts, nuts, screws, peg stays and other mild steel fittings shall be treated for corrosion as per relevant Indian Standards. Putty for glazing shall conform to IS – 420.

Doors, windows and ventilators, etc., shall be truly square and free from twist and warp. They shall be constructed of sections which have been cut to the required lengths and welded or riveted at the corners as per standard specifications.

All steel surfaces shall first be thoroughly cleaned free of rust scale or dirt and mill scale by approved means and shall be painted with one coat of approved primer conforming IS – 102 before despatch. Alternatively if specified they may be galvanised by the “Hot dip” zinc spray or electro galvanising process described IS – 1361. Doors, windows and ventilators shall be fixed in positions, as specified under IS 1081.

Whenever contractor is required to supply the doors, windows and ventilators etc., he shall first submit to the Engineer-in-charge, the details about source of supply, detailed drawing and specifications etc., for prior approval.

10. M.S Rolling Shutters :

It shall be of approved quality, made out of 18 gauge 75 mm black laths mechanically operated by reduction gear type mechanism. It shall be fitted with two self-aligning ball bearing with locking arrangements (both inside and outside) including M.S pressed side guides bottom rails brackets and top rolling spring pressed etc., complete provided with locking arrangements for padlocks, pulling hooks, handles, top cover etc., It shall be painted with one coat of approved primer conforming to Is – 102 before despatch.

11. Wooden Doors, Windows and Ventilators :

All wood work for doors, windows, ventilators cup board, shelves, etc., conform to relevant IS specification and TNBP 82 and shall be well seasoned teak wood or well seasoned country wood

Place
Date

Signature of the Bidder
(NAME & ADDRESS WITH SEAL)



BHARAT HEAVY ELECTRICALS LIMITED

POWER PLANT PIPING UNIT

THIRUMAYAM- 622 507

CONTRACTS DEPARTMENT

Phone : 04333279551

E.mail : ilango@bheltry.co.in Website : www.bhel.com

Tender No:PPPU:WC:14:015

Tender Notice

Dt. 04.10.2014

(pillamarudu or karumarudu) as the case may be. Timber shall be best quality and shall be free from knots, injurious open shales, bore holes, decay, soft or spongy spots, hollow pockets and all other defects and blemishes. Timber shall conform to IS 1003 (Part 1). Size of doors, windows and ventilators shall as specified in the relevant item of schedule and detailed drawings and generally in conformity with IS – 1003, part I and part II. The rates for doors, windows and ventilators etc., shall be for the finished work inclusive of fixing them in position with necessary iron hold fasts and furniture fitting of oxidized iron or aluminium or oxidized brass as stated in the description of the relevant items of the bill of quantities and as directed by the Engineer-in-charge. Fittings and furniture shall be of best quality and machine made and robust type. Wherever glazed shutters are to be provided, the cost of glass panes of specified thickness and fixing them in position should be included in the quoted rate. All glass shall be of superior quality from approved manufacturer. In case of solid core flush doors, they should conform to IS:2202 Part I and Part II. The flush door shutters should have a finished thickness as specified in the scheduled item. Flush door shutters shall be obtained from firms of repute as approved by the Engineer-in-charge.

12. ROOFING : (A) R.C.C Slabs :

Roof slab shall be of RCC of specified mix conforming to IS : 456, with adequate main tensile, transverse and adhesive reinforcement of ribbed steel bars of mild steel rounds. Unless otherwise mentioned the rates for RCC slab shall include cost of concrete, centering and shuttering charges, vibration charges, rounding of corners, curing and finishing etc., complete. Expansion joints in reinforced cement slabs shall be as per TNBP 30.

The ceiling should be finished as per Clause 30 of TNBP. No extra payment shall be made towards cost of ceiling plaster necessitated on account of defective centering materials used or poor workmanship.

The top of roof slab shall be finished with weathering course treatment if so specified. The weathering course work shall conform to TNBP 44-HJ and consist of concrete with broken brick in neat slacked lime of specified thickness finished with one course of pressed split tiles / pressed tiles of specified thickness and size as described in the bill of quantities.

(B) Roofing and Side Cladding with A.C. sheets :

The A.C. sheets shall be of specified and approved quality and shall conform to IS 459- 1962 in all respects. The sheet shall be laid with the smooth side upwards and with a minimum end lap of 15cm. and for every flatter slopes this should be 20cm. The laying operation shall include scaffolding works involved. Sheets shall be secured to the purlins by means of 8mm galvanized iron J or L hook bolts and nuts. The grip of the hook bolt on the side of the purlin shall be not less than 25mm. Each bolt shall have a bitumen washer and galvanized iron washer placed over the sheet before the nuts are screwed down from above. Hole for hook bolts etc., shall be drilled and not punched in the ridges of the corrugations in the exact positions. The diameter of these holes shall 1.5 mm more than the diameter of the fixing bolts. The payment will be square metre basis of the laid area.

13. A.C. Rain Water Pipes

Place
Date

Signature of the Bidder
(NAME & ADDRESS WITH SEAL)



BHARAT HEAVY ELECTRICALS LIMITED

POWER PLANT PIPING UNIT

THIRUMAYAM- 622 507

CONTRACTS DEPARTMENT

Phone : 04333279551

E.mail : ilango@bheltry.co.in Website : www.bhel.com

Tender No:PPPU:WC:14:015

Tender Notice

Dt. 04.10.2014

The pipes shall be of standard quality conforming to IS 1628. These shall be straight, true smooth and regular in thickness. They shall be free from cracks and other flaws. The supply shall include all necessary pipe fittings and accessories.

All pipes shall be fixed to wall or columns by standard M.S butt holder clamps of approved make. The spigot of the upper pipe shall be properly fitted into the socket of the lower pipe, such that there is uniform annular space for filling with the jointing materials. One third depth of this annular space is to be filled with spun yarn soaked in bitumen of approved quality and properly pressed with caulking tool. The remaining two, third depth of the joint is to be filled with Cement Mortar 1:2 (1Cement : 2 coarse sand) and shall be pressed with caulking tool and finished smooth at the top at an angle of 45 Deg. sloping up.

The rate shall include supplying and fixing pipes with specials and accessories, including sizing as required, jointing, testing, cutting of walls and making good necessary scaffolding etc., complete.

14. Flooring :

Flooring shall consist of a base course of cement concrete of specified thickness and proportion laid over the compacted earth or sand filling as specified and a finishing layer of concrete, mosaic, glazed tiles or any other material as specified to be laid. Flooring work for Factory shop floors as well as mosaic flooring shall be done as per the special specifications.

The bed flooring shall be prepared either level or sloped as per relevant drawing or as instructed by the Engineer-in-charge. Filling in basement with earth or sand shall be in accordance with TNBP 25. On the prepared bed, cement concrete of specified mix and thickness shall be laid and well consolidated.

A. Ellispattern, 1st Sort Flooring

On the clean wet surface of the concrete base before it has set, will be laid a layer of cement concrete to give a finished depth of 20/25 mm over the base concrete. The cement concrete will be of 1:3 proportion (one cement and 3 hard broken stone chippings 3 to 10 mm Size). To make a coloured floor red oxide iron powder or other approved materials should be mixed with cement at the rate 10% of the weight of cement or as directed by the Engineer-in-charge. Ellis pattern flooring shall be done as described under clause 41-G of TNBP.

B. Glazed Tile Flooring

The tiles shall be of ceramic white or coloured and of specified dimensions as described in the schedule item. The top surface of tiles shall be glazed with a neat finish of uniform colour and texture and free from flaws, cracks, craze, specks or other imperfections. Tiles shall be true and shape with straight edges, non-absorbing and non – fading. Samples of tiles together with manufacturer's literature shall be submitted to the Engineer-in-charge for approval. Tiles shall conform to IS 177 latest.

Over the prepared surface of the floor a bedding layer of Cement Mortar (1:3) of specified thickness shall be laid-in-proper level and slope using screed patterns. The bedding layer shall be deeply scratched while it is set. A mortar set bed of 6mm thickness in cement lime mortar 1:1:3 (one

Place
Date

Signature of the Bidder
(NAME & ADDRESS WITH SEAL)



BHARAT HEAVY ELECTRICALS LIMITED

POWER PLANT PIPING UNIT

THIRUMAYAM- 622 507

CONTRACTS DEPARTMENT

Phone : 04333279551

E.mail : ilango@bheltry.co.in Website : www.bhel.com

Tender No:PPPU:WC:14:015

Tender Notice

Dt. 04.10.2014

cement one lime putty and three sand), shall be laid over the bedding layer. After mortar setting, bed has been leveled, a skin of neat cement shall be trowelled to the mortar setting bed immediately before the tiles are set. As soon as the mortar setting bed has sufficiently hardened, all tiles shall be finally secured in place and gently beaten in and finished surface brought to desired level. When grouting the glazed tiles, special care shall be taken to prevent scratching of the glazed surface. Joints shall be pointed with white or coloured cement to match the tile surface and cured. No joint shall be more than 1.5 mm thick.

15. White Washing and Colour Washing

White washing and colour washing shall be done as per clauses 63 and 64 of TNBP. The surface shall be thoroughly cleaned off mortar drops and foreign matter. All patchings must be scraped properly. The white washing shall be done from pure shell lime / Janathacem. Samples of lime shall be got approved by the Engineer-in-charge. The wash shall be applied with a brush, the coats being laid on vertically and horizontally alternatively, each coat being allowed to dry before next coat is applied. For colour washing the desired shade shall be obtained by mixing approved quantity of colouring matter or distemper with shell lime solution and applied as per white. The contractor shall take every precaution to prevent white wash being splashed on wall, floor and other places and articles not to be white washed. No colour wash shall be done unless a sample pattern of the mixed colour has been approved by the Engineer-in-charge. The rates shall be inclusive of scaffolding charges, cost of ladder etc.,

16. Painting

All painting work shall be done in accordance with TNBP-66 and the relevant Indian Standard Specifications. Paints, varnishes, cement paints etc., shall be the highest grade products of well known approved manufacturer and shall be delivered to site in original sealed containers. It is desired that materials of one manufacturer only shall be used as far as possible. Colours shall be uniform and nonfading. Samples of all colours selected shall be submitted to the Engineer in charge for approval before bulk purchase is made. All finished work shall match corresponding samples kept with the Engineer.

Preparation of Surface :

Before painting wooden surfaces, protruding timber fibres shall be removed and nail marks shall be covered with putty. The surface shall be thoroughly cleaned and sand prepared. In case of steel work it shall be scraped, well brushed and cleaned free of rust, scale dirt. Base preparation for painting concrete, masonry and plastered surfaces shall be carried out as per IS 2395 – Part I. Before actually proceeding with the work of painting the concrete, masonry and plastered surfaces, it shall be verified that the surfaces shall be completely dry, free from efflorescence and alkaline effect.

Application

The primer shall be applied with brushes and spread as evenly and as smooth as possible. For steel work a priming coat of Red Oxide / Zinc Chromate paint shall be applied. Painting shall be done by

Place
Date

Signature of the Bidder
(NAME & ADDRESS WITH SEAL)



BHARAT HEAVY ELECTRICALS LIMITED

POWER PLANT PIPING UNIT

THIRUMAYAM- 622 507

CONTRACTS DEPARTMENT

Phone : 04333279551

E.mail : ilango@bheltry.co.in Website : www.bhel.com

Tender No:PPPU:WC:14:015

Tender Notice

Dt. 04.10.2014

skilled labourers in a work-man like manner. All coats shall be of proper consistency and shall be well brushed out, so that no brush marks are visible. The under coating should be nearest to the specified colour of the finishing coat. Unless otherwise specified ready mixed synthetic enamel paints shall be used for painting, wood and steel work. Under coats should be completely dry before finishing coat is taken up. Priming coat and under coat shall be rubbed with sand paper and dusted clean. The finished coat of approved paint shall then be applied.

17. Cement Painting

Cement Paint solution shall be applied to the surface with hair brushes in a number of coats to get uniform finish. After the first coat of paints has hardened, it shall be cured with water atleast for 24 hours. The surface shall be wetted again before the application of the second coat. Atleast 24 hours should lapse between the two coats, number of coats shall be as specified in the schedule of quantities. It shall be kept damp atleast for seven days.

18. French Polish

French polish to be used shall comply with IS 348. Polishing shall be obtained by dissolving 1 lbs, of shellac in one gallon of methylated spirit without applying any source of heat. After the shellac has dissolved $\frac{1}{4}$ lbs of cobalt, $\frac{1}{4}$ lbs of lobano and 0.4 oz of crystals of desired pigment shall be added. The solution shall be applied with a pad of fine muslin cloth tied as per general practice. The pad shall be dipped into the solution and wrung with fingers and be rubbed hard on the surface in this way, the first coat is to be given after this gets dried up, the successive coats shall be given in the same fashion till the mirror like surface is obtained. The wood to be polished shall be first applied with a filler composed of 1.25 Kg. of whiting mixed with one litre of methylated spirit and then sand papered when dry. The finished surface shall have uniform texture and gloss. Approved transparent sealer shall only be used in base preparation.

Place
Date

Signature of the Bidder
(NAME & ADDRESS WITH SEAL)



BHARAT HEAVY ELECTRICALS LIMITED

POWER PLANT PIPING UNIT

THIRUMAYAM- 622 507

CONTRACTS DEPARTMENT

Phone : 04333279551

E.mail : ilango@bheltry.co.in Website : www.bhel.com

Tender No:PPPU:WC:14:015

Tender Notice

Dt. 04.10.2014

SPECIAL SPECIFICATION FOR CONTROLLED CONCRETE

a) PROPORTIONING MIX:

The proportion of aggregate, Cement and water to be used for controlled concrete shall be designed by preliminary tests of the materials to be actually used to obtain the densest to workable concrete requiring the minimum quantity of cement paste for binding the materials to give the required strength. However the maximum total quantity of aggregate by weight per 50 kg. of cement shall not normally exceed 450kg All proportions shall be by weight. However water may be added by weight or volume.

b) MIX DESIGN:

Immediately upon the receipt of the award of the contract, the Contractor shall inform the Engineer-in-charge the exact location of the sources of materials which he proposes to use and get the materials approved. The mix with the actual approved materials to be used shall be got designed by the Contractor in an approved laboratory chosen by BHEL and got approved by the Engineer-in-charge. These proportions shall be used so long as the materials continue to be the same quality and from the same sources. If during the progress of work, the Contractor wishes to change the materials, the proportions shall be fixed on the basis of fresh preliminary tests to give the required strength. No change of materials shall be allowed unless fresh tests with new materials show satisfactory results.

c) STRENGTH REQUIREMENTS OF CONCRETE:

Controlled concrete shall be in the following grades, M 15, M 20, M 25, M 30, M 35 & M 40. The concrete mix shall be designed to produce the grade of concrete having the required workability and characteristic strength not less than the appropriate values (as per I.S. 456) as given in table below:

Sl. No	Grade of. Concrete	Specified Characteristic Cube Strength	
		Preliminary test N/mm2	Works test N/mm2
1.	M 15	20	15
2.	M 20	26	20
3.	M 25	32	25
4.	M 30	38	30
5.	M 35	44	35
6.	M 40	50	40

d) WORKABILITY OF CONCRETE:

Place
Date

Signature of the Bidder
(NAME & ADDRESS WITH SEAL)



BHARAT HEAVY ELECTRICALS LIMITED

POWER PLANT PIPING UNIT

THIRUMAYAM- 622 507

CONTRACTS DEPARTMENT

Phone : 04333279551

E.mail : ilango@bheltry.co.in Website : www.bhel.com

Tender No:PPPU:WC:14:015

Tender Notice

Dt. 04.10.2014

The proportions chosen shall be such that the concrete is of adequate workability for the conditions prevailing on the work in question, and shall be properly compacted. Water shall be added to the mixer to give the required workability. The water content of each batch shall be adjusted as necessary to maintain the required workability with simultaneous adjustment of cement concrete such that the water cement ratio is not changed. The workability tests shall be carried out in accordance with IS : 1199 - Latest, "Methods of sampling and analysis".

Workability of concrete shall be controlled by direct measurement of water content, making allowance for any surface water in the fine and coarse aggregates. Allowance shall be made for surface water present in the aggregate when computing the water content. Surface water shall be determined by one of the field methods described in IS : 2386, Part III.

e) CONSISTENCY AND SLUMP:

The concrete shall have a consistency such that it will be workable in the required position. It shall be of such consistency that when properly vibrated it will flow around reinforcing steel and all embedded parts. The slump for concrete as determined by slump tests as per Indian Standard 456 (latest edition) shall not exceed the maximum slumps indicated below for each type of construction as approved by the Engineer-in-charge.

Slum in MM	Type of Construction		Workability
	Min.	Max.	
Medium	40	80	All RCC works

The contractor shall not place concrete having a slump outside the limits specified without the approval of the Engineer-in-charge.

Atleast one slump test shall be made for every compressive strength test carried out. More frequent tests shall be made if there is a distinct change in job conditions or if required by the Engineer-in-charge.

f) TESTS:

Test shall conform to the specifications laid down in IS : 456. These tests shall be got done in an approved laboratory and in accordance with IS : 516 - Latest at the cost of the Contractor (for making necessary cube moulds, transporting the cubes to the Laboratory and all other incidental etc.). The test fees for the cubes shall be borne by the contractor.

Place
Date

Signature of the Bidder
(NAME & ADDRESS WITH SEAL)



BHARAT HEAVY ELECTRICALS LIMITED

POWER PLANT PIPING UNIT

THIRUMAYAM- 622 507

CONTRACTS DEPARTMENT

Phone : 04333279551

E.mail : ilango@bheltry.co.in Website : www.bhel.com

Tender No:PPPU:WC:14:015

Tender Notice

Dt. 04.10.2014

In order to ensure proper quality control sampling of the concrete of each specification placed on any day in work shall be done in accordance with the following table.

Quantity of Concrete in work	Total Number of samples(each sample to consist of 6 test cubes)
Upto 5.00 Cu.m.	1
Greater than 5.00 Cu.m. and less than 15.00 Cu.m	2
Greater than 15.00 Cu.m. and less than 30.00 Cu.m.	3
Greater than 30.00 Cu.m. and less than 50.00 Cu.m.	4
Greater than 50.00 Cu.m.	4 + one additional sample for each additional 50 Cu.m. or part thereof.

i) The sampling shall be spread as evenly as possible throughout the day. When wide changes in weather conditions occur during concreting, additional samples may be taken as desired by Engineer-in-charge. Each sample shall consist of 6 cubes of 15 x 15 x 15 cm concrete. Test cubes shall be kept immersed in water until required for test which will be usually at 7 days and minimum crushing strength of not less than the following:

Grade of Concrete	M15	M20	M25	M30	M35	M40
Crushing strength in N/mm ² at the end of						
a) 7 days	10	13.50	17	20	23.50	27
b) 28 days	15	20	25	30	35	40

All costs connected with the preliminary tests for proportioning the mix, sampling, curing, handling, other incidental charges, labour charges and cost of materials shall be borne entirely by the Contractor. Testing charges for cubes (work tests) shall be borne by contractor. Such testing shall normally be conducted at the BHEL Central Laboratory or any other approved laboratory as directed by the Engineer-in-charge.

All samples for tests shall be taken in the presence of Engineer-in-charge and the Contractor or his authorised agents.

Place
Date

Signature of the Bidder
(NAME & ADDRESS WITH SEAL)



BHARAT HEAVY ELECTRICALS LIMITED

POWER PLANT PIPING UNIT

THIRUMAYAM- 622 507

CONTRACTS DEPARTMENT

Phone : 04333279551

E.mail : ilango@bheltry.co.in Website : www.bhel.com

Tender No:PPPU:WC:14:015

Tender Notice

Dt. 04.10.2014

A set of six specimens from random mixer batches, shall constitute a test, three being tested for 7 days and three being tested for 28 days strength.

The strength test result shall be the average strength of the three companion test specimens, tested at 28 days, except that, if one specimen in a test shows manifest evidence of improper sampling, moulding or testing, the result shall be discarded and the remaining two strengths averaged.

ii) Normally, 7 days and 28 days tests shall be made on specimens. For any mix, a correlation between 7 days and 28 days strengths may be made in the laboratory. Soon after a job starts, a similar correlation will be evolved for samples of a concrete taken from the mixer. After that correlation has been established, the results of the 7 days test may be used as an indicator of the compressive strength which should be expected at 28 days, provided such results are consistent, if 7 days tests shown compressive strength that are too low, corrective measures shall be taken atonce, at the Engineer's direction, without waiting for the results of the 28 days tests.

iii) Each class of concrete shall meet the following strength requirements:

The average of any three consecutive strength tests shall have a value equal to or greater than the specified strength subject to the condition that only one out of three consecutive tests may give a value less than the specified strength but this shall not be less than 90% of the specified strength.

iv) In the event that concrete tested in accordance with the requirements of this specification, fails to meet the requirement, the Engineer shall have the right to require any one or all the following.

1. Changes in the concrete mix proportions for the remaining work.
2. Curing and testing of the concrete represented by the tests which failed.
3. **Replacement of any such portions of the structure. (No payment for dismantled concrete, associated from worker or reinforcement shall be made. Embedded fixtures, reinforcement and adjoining structures, damaged during dismantling shall be made good by the Contractor at his own expense).**
4. Extended curing of the concrete represented by the specimen.
5. The contractor shall carry out all such measures as directed at his own expense.

Load tests of structural members may be required by the Engineer when the strength of the job control tests falls below the required strength and is not acceptable as per "Acceptance Criteria" stated earlier. The entire cost of the load test shall be borne by the Contractor. If the load testing is decided by the Engineer, the member under consideration shall be subjected to a superimposed load equal to one and quarter (1.25)

Place
Date

Signature of the Bidder
(NAME & ADDRESS WITH SEAL)



BHARAT HEAVY ELECTRICALS LIMITED

POWER PLANT PIPING UNIT

THIRUMAYAM- 622 507

CONTRACTS DEPARTMENT

Phone : 04333279551

E.mail : ilango@bheltry.co.in Website : www.bhel.com

Tender No:PPPU:WC:14:015

Tender Notice

Dt. 04.10.2014

times the specified superimposed load used for design and this load shall be maintained for a period of 24 hours before removal.

The detailed procedure of the test shall be decided by the Engineer-in-charge.

If, within 24 hours of the removal of the load, the structure does not show a recovery of atleast 75 percent of the deflection after the 24 hours under load, the test should be repeated. The structure should be considered to have failed to pass the test if the recovery after the second test is not atleast 80 percent of the maximum deflection occurring during the second test.

If the member shows evident failure, such changes as are necessary to make the structure adequately strong, shall be made by the contractor free of cost to the Department. If on the other hand, the failure becomes apparent, the Engineer under special circumstances, can retain the portion of the structure under test, provided suitable strengthening and or load dispersed arrangement is feasible. Cost of such strengthening or load dispersed arrangement shall be borne by the Contractor.

Load test shall not be made until the expiry of 56 days of effective hardening of the concrete.

If a portion of the structure is found to be unacceptable it shall be dismantled and replaced by a fresh structure as per specification. The cost of such dismantling and reconstruction should be borne by the Contractor.

The proportions of cement, fine aggregate, coarse aggregate and water necessary to produce a concrete mix which will fulfill the requirements of this specification for each grade of concrete shall be determined on the basis of trial mixes conducted with the samples of the material to be used in the work by the Engineer-in-charge in the field Laboratory.

All mix design and test data and results shall be maintained as part of the record of the contract and shall be signed by the Engineer-in-charge and the Contractor. A register showing such record shall be maintained at site of work as shown below.

Place
Date

Signature of the Bidder
(NAME & ADDRESS WITH SEAL)



BHARAT HEAVY ELECTRICALS LIMITED

POWER PLANT PIPING UNIT

THIRUMAYAM- 622 507

CONTRACTS DEPARTMENT

Phone : 04333279551

E.mail : ilango@bheltry.co.in Website : www.bhel.com

Tender No:PPPU:WC:14:015

Tender Notice

Dt. 04.10.2014

NAME OF WORK:

Sl. No.	Date & Time	Sample No.	No. of Cubes	Identifi- cation marks	Proportions of mix	Description of portion of work represented by sample and quantity of concrete represented by the sample	Initials of S.O/A.E. in whose presence sample is taken	Date of test
(1)	(2)	(3)	(4)	(5)	(6)	(7)	(8)	(9)

7 days test result of each cube	Average 7 days strength	Standard 7 days strength	Date of test cube	28 days last result of each cube	Average 28 days strength	Standard 28 days strength	Remarks (the reference Nos. of test report	Review and Remarks by Asst. Engineer	Review and Remarks by Execu- tive
---	-------------------------------	--------------------------------	----------------------------	---	--------------------------------	---------------------------------	---	---	--

Place
Date

Signature of the Bidder
(NAME & ADDRESS WITH SEAL)

	<p align="center">BHARAT HEAVY ELECTRICALS LIMITED POWER PLANT PIPING UNIT THIRUMAYAM- 622 507 CONTRACTS DEPARTMENT</p>
Phone : 04333279551	E.mail : ilango@bheltry.co.in Website : www.bhel.com

Tender No:PPPU:WC:14:015

Tender Notice

Dt. 04.10.2014

							should also be recorded here)		Engineer
(10)	(11)	(12)	(13)	(14)	(15)	(16)	(17)	(18)	(19)

Place
Date

Signature of the Bidder
(NAME & ADDRESS WITH SEAL)



BHARAT HEAVY ELECTRICALS LIMITED

POWER PLANT PIPING UNIT

THIRUMAYAM- 622 507

CONTRACTS DEPARTMENT

Phone : 04333279551

E.mail : ilango@bheltry.co.in Website : www.bhel.com

Tender No:PPPU:WC:14:015

Tender Notice

Dt. 04.10.2014

STRUCTURAL STEEL WORKS

1. Broadly, the work under this contract comprises of conveying of raw structural steel sections from BHEL Store to site fabrication shop, fabrication of steel work at the site fabrication shop including one priming coat of Zinc Chromate/red oxide primer, transportation of fabricated steel structures to the erection site including loading, unloading, leading, stacking as required and all handling costs, erection of steel work over prepared foundations or on RCC brackets as the case may be and painting of steel work two coats with approved synthetic enamel ready mixed paint or as specified in the Bill of quantities carrying from BHEL stores and erection of cloaking items etc. complete.
2. If found necessary the tenderer may also be required to supply some raw structural steel sections also as required for this work in accordance with the latest editions of the Indian Standard Specifications noted below:-

IS 2062 & IS 1977. He will be required to submit the necessary test certificates for the materials so supplied for use on this work.
3. The detailed fabrication drawings as approved for fabrication will be the responsibility of BHEL. The Detailed Shop Drawings will be supplied by BHEL to the contractor progressively to suit the fabrication and erection sequence. The Contractor shall not depart from the drawings approved by BHEL without the written permission of the Engineer-in-charge.
4. Based on the detailed shop Drawings approved by the BHEL the Contractor shall prepare at his cost, the Drawing Office Despatch Lists (abbreviated as D.O.D.L.'s) and get them approved by BHEL. These shall contain the drawing number, the designation of items, number of pieces, based on the section weights as adopted for supply of raw materials without deduction for bolt holes and skew cuts. The DOD Lists shall form the basis for payment.
5. Rate quoted against item(s) of the Bill of Quantities cover the fabrication of all items involved and shall therefore be an Overall-average-rate. The actual quantities for payment shall be based on the drawing office despatch lists to be prepared by the Contractor and got approved by BHEL as aforesaid.
6. All Civil works like preparation of foundations for columns, including embedding of holding down bolts etc., also have to be carried out and hence included in the present enquiry. All works shall be performed and completed in a thoroughly workmen like manner and the contractor shall follow the best modern practice in the manufacture of high grade structures not withstanding any omission in the specifications.
7. (a) Fabrication shall generally be in accordance with IS 800 (latest issue) entitled "Code of practice for use of structural steel in general building constructions". Welding shall be in accordance with IS 816 entitled "Code of practice for use of metal arc welding for general

Place
Date

Signature of the Bidder
(NAME & ADDRESS WITH SEAL)



BHARAT HEAVY ELECTRICALS LIMITED

POWER PLANT PIPING UNIT

THIRUMAYAM- 622 507

CONTRACTS DEPARTMENT

Phone : 04333279551

E.mail : ilango@bheltry.co.in Website : www.bhel.com

Tender No:PPPU:WC:14:015

Tender Notice

Dt. 04.10.2014

construction in mild steel". The contractor shall provide necessary splicing as approved by the Engineer-in-charge, to suit the available lengths of raw steel, and no extra amount shall be paid on this account. Any specifications not covered by the Relevant Indian Standard Codes of practice shall be in accordance with the relevant BS or in its absence in accordance with the well established standard Engineering practice to be acceptable to BHEL.

(b) Under the contract, site fabrication is to be adopted for which a suitable site near and inside the factory premises will be made available by BHEL at free of ground rent. The Contractor shall provide all plant and equipments, tools covered sheds and other facilities required for site fabrication work at his own cost.

(c) The Contractor shall take into consideration the existing foundation structures and make necessary provisions in the fabricated components with the approval of the Engineer-in-charge so that proper alignment, vertically and easy connection / erection of structures is ensured, should this involve any extra work on the part of the contractor beyond his normal scope, the same will be paid for at mutually agreed rates.

8. All fabricated steel work shall be given one coat of Red Oxide / Zinc Chromate primer conforming to Relevant IS code before erection. All fabricated steel work shall be match marked suitably to facilitate their erection in position without any difficulty.
9. Materials to be supplied by this organisation will be supplied in standard/random sizes/lengths as stocked by BHEL. Hence the Contractor will be required to receive extra materials to cover conversion, wastage, alteration etc. He shall do so without any claim for extra payment, whatsoever on this account.
10. All breakages after the A.C. materials are handed over to the contractor shall be to Contractor's account. As far as possible partially broken A.C. materials should be cut suitably and used for smaller sizes with the approval of BHEL, without any extra claim. A breakage allowance of 3% of the consumed quantity is permissible for A.C. materials, if size of sheets supplied vary with actual requirement the actual size as supplied shall be allowed, for material accounting.
11. The Contractor should prepare in advance cutting lists for materials so as to obtain efficient and economical use of all types of materials including steel.
12. Normally no night work will be permitted. But in case of emergency and urgent in nature where night work is warranted, the Contractor shall arrange for night works providing all facilities including illumination at his own cost, after obtaining written permission from Engineer-in-charge under intimation to Security and Safety Departments.
13. The Contractor shall closely scrutinise all the drawings for the work issued by this organisation and bring to the notice of the Engineer-in-charge any discrepancies/ omissions

Place
Date

Signature of the Bidder
(NAME & ADDRESS WITH SEAL)



BHARAT HEAVY ELECTRICALS LIMITED

POWER PLANT PIPING UNIT

THIRUMAYAM- 622 507

CONTRACTS DEPARTMENT

Phone : 04333279551

E.mail : ilango@bheltry.co.in Website : www.bhel.com

Tender No:PPPU:WC:14:015

Tender Notice

Dt. 04.10.2014

noticed in the drawings before undertaking the actual work.

14. M/s BHEL through their duly authorised representative shall have all reasonable times access to the Contractor's premises or works and shall have the power at all reasonable times to inspect any portion of the work or examine the materials and workmanship of the structures during their manufacture and test. The Contractor shall give notice in writing to the inspecting Engineer of BHEL when the materials to be supplied are ready for inspection and test, no materials shall be used on the fabrication work until the inspecting Engineer has certified in writing that such materials have been inspected and approved by him. The contractor shall provide at his own cost all facilities for the required tests on fabricated structures as required by the Engineer-in-charge. Defective fabrication structures shall be made good/replaced by the Contractor at his own cost to the full satisfaction of BHEL. This also applies to loss or damage of raw materials, if special tests only will be borne by BHEL.
15. Weekly progress reports shall be submitted giving in detail the position of receipt of raw materials, progress of fabrication and completion of fabricated structures etc. The contractor shall submit at such times as may be requested by the Engineer-in-charge, schedules showing the programme and order in which the Contractor proposes to carryout the fabrication and erection works with dates and estimated completion times for various portions of the work. Such schedules shall be approved by the Engineer-in-charge prior to the starting of the relevant works.
16. BHEL would expect the contractor to take up simultaneously wherever possible both fabrication and erection of structures especially where a good deal of assembly work, which is in fact a continuation of the fabrication work, is required to be done at site. The painting and cloaking items of works, wherever possible, should be done simultaneously to save time. The Contractor may with the prior approval of BHEL sublet the work. The main contractor shall however, be responsible for all works executed on his behalf by the sub-contractors.
17. **SETTING OUT AND ERECTING OF STEEL WORK:**
 - a) Erection of steel work shall generally be in accordance with the provision of IS 800 (Code of practice for use of structural steel in General Constructions).
 - b) Site assembly of members on the ground by welding, bolting or otherwise as specified in shall be inspected thoroughly by the Engineer-in-charge, or his authorized representative and approved before erection.
 - c) All equipments, facilities and consumables for site fabrication as well as erection plant requirement, etc., such as derricks, cranes, lifting tackles, wire ropes, chain pulley blocks, jacks, winches etc. as necessary shall be arranged for by the Contractor at his own cost. Care shall be taken to see that all equipments, tools and tackles and wire ropes etc. in use are always in good working conditions and fit for use. For all the tools and plants periodical calibration certificate from approved agency should be obtained. **The above lists should be**

Place
Date

Signature of the Bidder
(NAME & ADDRESS WITH SEAL)



BHARAT HEAVY ELECTRICALS LIMITED

POWER PLANT PIPING UNIT

THIRUMAYAM- 622 507

CONTRACTS DEPARTMENT

Phone : 04333279551

E.mail : ilango@bheltry.co.in Website : www.bhel.com

Tender No:PPPU:WC:14:015

Tender Notice

Dt. 04.10.2014

enclosed along with the tender.

- d) Frames shall be lifted at such points that they will not buckle or deform. Trusses shall be lifted only at nodes. Temporary bracing shall, if required, be provided at no extra cost, to relieve erection stresses.
- e) In the case of trusses and similar roof structures all or atleast a majority of the purlins and wind bracings, shall be erected side by side with the erection of these structures. Columns shall be erected true to plumb, (no screed bars provided and fixed by the Contractor over the prepared pedestals), true to center line, level and gauge of traveling cranes. Alignment of the columns, crane girders and rails shall be done very carefully using high precision survey instruments and necessary adjustments made to suit actual requirements. **A list of survey instruments proposed to be used shall be furnished in the tender.**
- f) All damages to the steel work caused during the transit or otherwise shall be made good to the full satisfaction of BHEL at Contractor's own cost, before erection.
- g) It shall be the sole responsibility of the Contractor to ensure accuracy of level, plumb, span and alignment of steel work before erection of other components.

18. **PAINTING AFTER ERECTION:**

- a) All steel work shall be given two coats of approved brands of first quality synthetic enamel ready mixed paint after erection (over the priming coat already provided). Painting shall be done as per IS 800. The shade, make, quality and other particulars of the paint proposed to be used, shall be subject to prior approval by BHEL.
- b) It is the responsibility of the Contractor to procure sufficient quantities of the approved paints well in advance to ensure their availability in time.

19. **TIME ALLOWED (Period of Contract)**

The following programme should be strictly followed.

- (i) Fabrication of structural steel works } Progressively from the date of award of
to be completed } work
- (ii) Erection, painting of the above } Progressively from the date on
structures, supply and erection of } which completion of civil work and
cloaking items etc. to be completed } the readiness of site declared as fit for
} erection

20. The contractor will have to provide and fix the necessary screed bars etc. at his own cost in proper line, level and position to facilitate the erection work. Further, the contractor should

Place
Date

Signature of the Bidder
(NAME & ADDRESS WITH SEAL)



BHARAT HEAVY ELECTRICALS LIMITED

POWER PLANT PIPING UNIT

THIRUMAYAM- 622 507

CONTRACTS DEPARTMENT

Phone : 04333279551

E.mail : ilango@bheltry.co.in Website : www.bhel.com

Tender No:PPPU:WC:14:015

Tender Notice

Dt. 04.10.2014

lay and maintain necessary temporary approaches within his working areas at his own cost to facilitate his work and for easy movement of vehicles, cranes etc. deployed on the work. Only reasonable areas will be provided by BHEL.

21. Till the expiry of the maintenance period of SIX MONTHS after the completion of the entire contract work and handing over to BHEL, the contractor should retain the minimum equipments and staff required and should carry out the maintenance works with the least possible interference to the routine works of the new shop. Till the expiry of the maintenance period the contractor shall be responsible for all damages occurring due to any fault on his part or on the part of his workmen, sub-contractor or other agencies engaged by him.
22. BHEL shall have the right to take possession of or use any completed or partially completed part of the work. Such possession or use shall not be deemed to be acceptance of any work not in accordance with the contract.
23. The contractor shall observe all safety regulations and take necessary safety precautions as called for under the Factories Act or other relevant statute as applicable including the use of safety boots, safety belts, helmets and other equipments and accessories for ensuring safe execution of the contract and freedom from accidents.
24. The rates quoted in the Bill of Quantities of the tender for the fabrication item shall cover also the cost of preparation of DODL and similar incidental items. Fabrication works shall be undertaken only after the issue of approval of shop drawings.
25. The Contractor should co-operate with other contractors who may be executing their work in the same area in order to facilitate efficient execution of the entire project work in this area.
26. BHEL is registered as an indentor for materials on rate contract with DGS & D. Tenderers who are on DGS & D List of rate contracts should mention their rate contract number and furnish a copy of the rate contract document with the tender.
27. The Guarantee / Warranty period for this contract shall be SIX MONTHS from the date of completion of the entire work and handing over to BHEL. During this period the successful tenderer shall be at site on his own expense for replacement or repair of all defects arising out of faulty materials and/or workmanship.
28. Further particulars relating to design and fabrication and clarifications, if any, may be obtained on reference to the Sr. Dy.General Manager/Civil / Factory, BHEL, Tiruchirapalli-14 or his nominee.
29. The contractor shall engage a level-II NDT Inspector for inspection of NDT works.
30. Inspection will be done by BHEL Staff/Agencies appointed by BHEL for the works covered in the tender.

Place
Date

Signature of the Bidder
(NAME & ADDRESS WITH SEAL)



BHARAT HEAVY ELECTRICALS LIMITED

POWER PLANT PIPING UNIT

THIRUMAYAM- 622 507

CONTRACTS DEPARTMENT

Phone : 04333279551

E.mail : ilango@bheltry.co.in Website : www.bhel.com

Tender No:PPPU:WC:14:015

Tender Notice

Dt. 04.10.2014

31. Painting, DFT of primer should be 25 micron.
32. Finish coat Painting, DFT 20 micron for each coat. Paint shall be of first quality product of approved brand as per list of approved brands for materials enclosed in the price bid.
33. Pre heating and post heating required shall be as per AWS (latest).
34. Welded qualification is to be done before commencement of the work and approved & qualified welder only shall be engaged in work. Necessary testing charges shall be borne by the contractor.
35. For the supply of material the manufacturer's test certificate is to be produced.

Place
Date

Signature of the Bidder
(NAME & ADDRESS WITH SEAL)



BHARAT HEAVY ELECTRICALS LIMITED

POWER PLANT PIPING UNIT

THIRUMAYAM- 622 507

CONTRACTS DEPARTMENT

Phone : 04333279551

E.mail : ilango@bheltry.co.in Website : www.bhel.com

Tender No:PPPU:WC:14:015

Tender Notice

Dt. 04.10.2014

GENERAL QUALITY CONTROL PROCEDURE FOR STRUCTURAL STEEL WORKS

The following quality standards are required to be maintained in all the structural steel fabrication components.

1. All the raw materials will be generally conform to IS 2062-1999 or equivalent.
2. The welding electrodes shall be kept in oven only.
- 3a. Submerged Arc welding has to be done for crane girder flange to web joints and built up column as per the details given in the approved drawings.
- 3b. E7018 Welding electrode rods shall be used where the thickness of plates are 20mm and more and as specified in the drawings issued.
- 3c. All the other weld in crane girder and butt welds in columns and beams shall be done with E 7018 welding electrodes.
- 3d. All the welds in Nodal points of trusses and lattice girders shall be done with E 7018 welding electrodes.
4. Pre heating shall be done for plates having thickness 25mm & more and the temperature shall be maintained by checking with thermal chalk, as per quality standards.
5. All erection welding, of any component shall be done using E 7018 Welding Electrode.
6. 100% visual check shall be carried out for raw materials and welding on all components and the welding areas during inspection, to be tested for LPI / MPI / UT / Radiography / PWHT as provided in the Quality Control Procedure.
7. Base plate to column shall be perfectly checked for perpendicularity.
8. All the components shall be checked for dimension at fit-up stage itself before the commencement of welding operation.
9. Contractor shall buy & use Black Hex. bolts and nuts as per IS Specifications as detailed below for fabrication & erection of steel structures.

Black Hex Bolts	IS 1363 - 1984 Part – I (Class 5.6/5.8)
Black Hex Nuts	IS 1363 - 1984 Part - III
Plain MS washer	IS 2016 - 1975
Taper washer for beams	IS 5274 - 1975
Taper washer for channel	IS 5372 - 1975
Spring washer	IS 3063 - 1964
10. Contractor shall buy & use the following welding consumables as detailed below:

Place
Date

Signature of the Bidder
(NAME & ADDRESS WITH SEAL)



BHARAT HEAVY ELECTRICALS LIMITED

POWER PLANT PIPING UNIT

THIRUMAYAM- 622 507

CONTRACTS DEPARTMENT

Phone : 04333279551

E.mail : ilango@bheltry.co.in Website : www.bhel.com

Tender No:PPPU:WC:14:015

Tender Notice

Dt. 04.10.2014

a)	SMAW No.	Electrodes	Manufacturer
	1.	E 6013 & E 7018	D & H Secheron
	2.	E 6013 & E 7018	ESAB India Ltd.
	3.	E 6013 & E 7018	Modi Arc Electrode Co.
	4.	E 6013 & E 7018	D & H Welding Electrode (I) Ltd.
	5.	E 6013 & E 7018	Mantek Electrods (P) Ltd.
	6.	E 6013 & E 7018	Ador Welding Ltd.
	7.	E 6013 & E 7018	Varun Electrodes Pvt. Ltd.

b) SAW Wire

Sl.No.	Brand	Manufacturer
1.	AUTO melt Grade A	Ador Welding
2.	Mantek Grade A	Mantek Wires
3.	Metaspool S1 dia. 4mm	Precision Wires
4.	OK Aut Rod 12.08 L	ESAB India Ltd.

c) Flux

Sl.No.	Brand	Manufacturer
1.	Super S41	Super Elec Inds
2.	Mantek 22	Mantek Welded Flux Co.
3.	RMH Auto Weld Grade 1	RMH Chemicals
4.	SWP 40 T	Super Weld Prod

d) GMAW (Co2)

Electrode	Brand	Manufacturer
ER70S-6 Co2 WIRE	Automig-1	Ador Welding Ltd.
ER70S-6 Co2 WIRE	Esab MW1	Esab India Ltd., Chennai
ER70S-6 Co2 WIRE	Mantek Mig	Mantek Wiress
ER70S-6 Co2 WIRE	Nouvarc	Nouveaux Industries (P) Ltd., Kangayam
ER70S-6 Co2 WIRE	Autofil-6	Voltrac Electrode Pvt. Ltd., Tirupathi.
ER70S-6 Co2 WIRE	Prima Mig/Mag	Varun Electrodes Pvt. Ltd., Panipat.

11. Rolled steel sections of depth greater than 450mm need to be visually checked for lamination before the process of fabrication. The doubtful area to be tested for LPI and if lamination is found UT Test to be carried-out.

Place
Date

Signature of the Bidder
(NAME & ADDRESS WITH SEAL)



BHARAT HEAVY ELECTRICALS LIMITED

POWER PLANT PIPING UNIT

THIRUMAYAM- 622 507

CONTRACTS DEPARTMENT

Phone : 04333279551

E.mail : ilango@bheltry.co.in Website : www.bhel.com

Tender No:PPPU:WC:14:015

Tender Notice

Dt. 04.10.2014

12. The welding code of practice, procedures, specifications for electrodes / consumables etc., for manual welding and auto welding shall conform to AWS D1.1/D1.1M:2006 (Latest) and as per the QCP issued by BHEL component-wise.
13. All the fabrication and erection works shall have to be executed as per the QCP issued by BHEL.
14. All the fabrication and erection works will be inspected for Quality Control by a third party inspection agency as fixed by BHEL.

Place
Date

Signature of the Bidder
(NAME & ADDRESS WITH SEAL)



BHARAT HEAVY ELECTRICALS LIMITED

POWER PLANT PIPING UNIT

THIRUMAYAM- 622 507

CONTRACTS DEPARTMENT

Phone : 04333279551

E.mail : ilango@bheltry.co.in Website : www.bhel.com

Tender No:PPPU:WC:14:015

Tender Notice

Dt. 04.10.2014

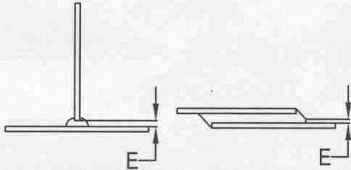
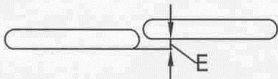
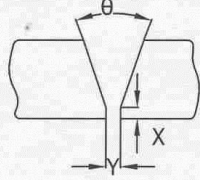
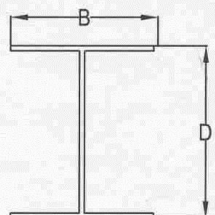
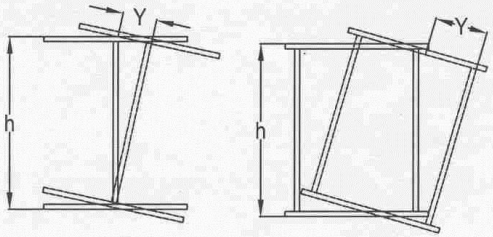
DESIGNATION	DETAIL OF SKETCH	PERMISSIBLE DEVIATION
FILLET WELD FIT UP	FIG:2 	MAX.LOCALISED GAP =1.5mm
BUTT WELD	FIG:3 	CUT OF ALIGNMENT = 3 mm MAX
FIT UP	FIG:4 	FOR ,X ,Y, θ REFER =1.2 &3 OF CL 7:4:3
SECTION SIZE	FIG:5 	D: UPTO 1M : ± 3mm 1M TO 2M : ± 4.5mm OVER 2M : + 7.5 mm - 4.5mm B:±3mm
TWIST ON SECTION (Y)		Y=0.005h 10 mm MAX

Place
Date

Signature of the Bidder
(NAME & ADDRESS WITH SEAL)



BHARAT HEAVY ELECTRICALS LIMITED

POWER PLANT PIPING UNIT

THIRUMAYAM- 622 507

CONTRACTS DEPARTMENT

Phone : 04333279551

E.mail : ilango@bheltry.co.in Website : www.bhel.com

Tender No:PPPU:WC:14:015

Tender Notice

Dt. 04.10.2014

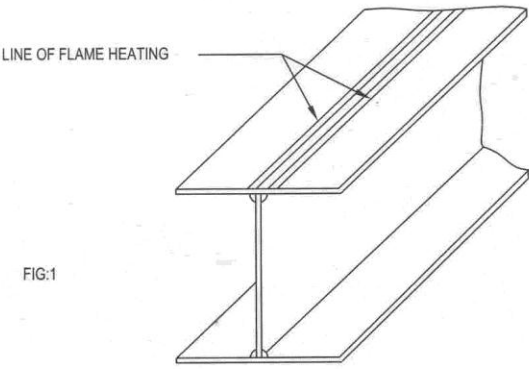

LINE OF FLAME HEATING

FIG:1

CORRECTION OF FLANGE WARPAGE

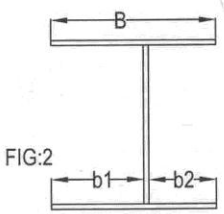
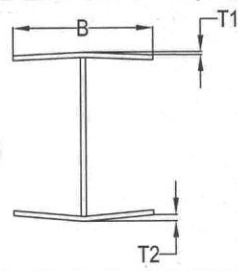
DESIGNATION	DETAIL OF SKETCH	PERMISSIBLE DEVIATION
WEB SHIFT	 <p>FIG:2</p>	$\frac{b1 - b2}{2} = 2\text{mm}$
FLANGE WARPAGE	 <p>FIG:3</p>	$T1+T2 = \frac{B}{100} \text{ OR } 6\text{MM}$

Place
Date

Signature of the Bidder
(NAME & ADDRESS WITH SEAL)



BHARAT HEAVY ELECTRICALS LIMITED

POWER PLANT PIPING UNIT

THIRUMAYAM- 622 507

CONTRACTS DEPARTMENT

Phone : 04333279551

E.mail : ilango@bheltry.co.in Website : www.bhel.com

Tender No:PPPU:WC:14:015

Tender Notice

Dt. 04.10.2014

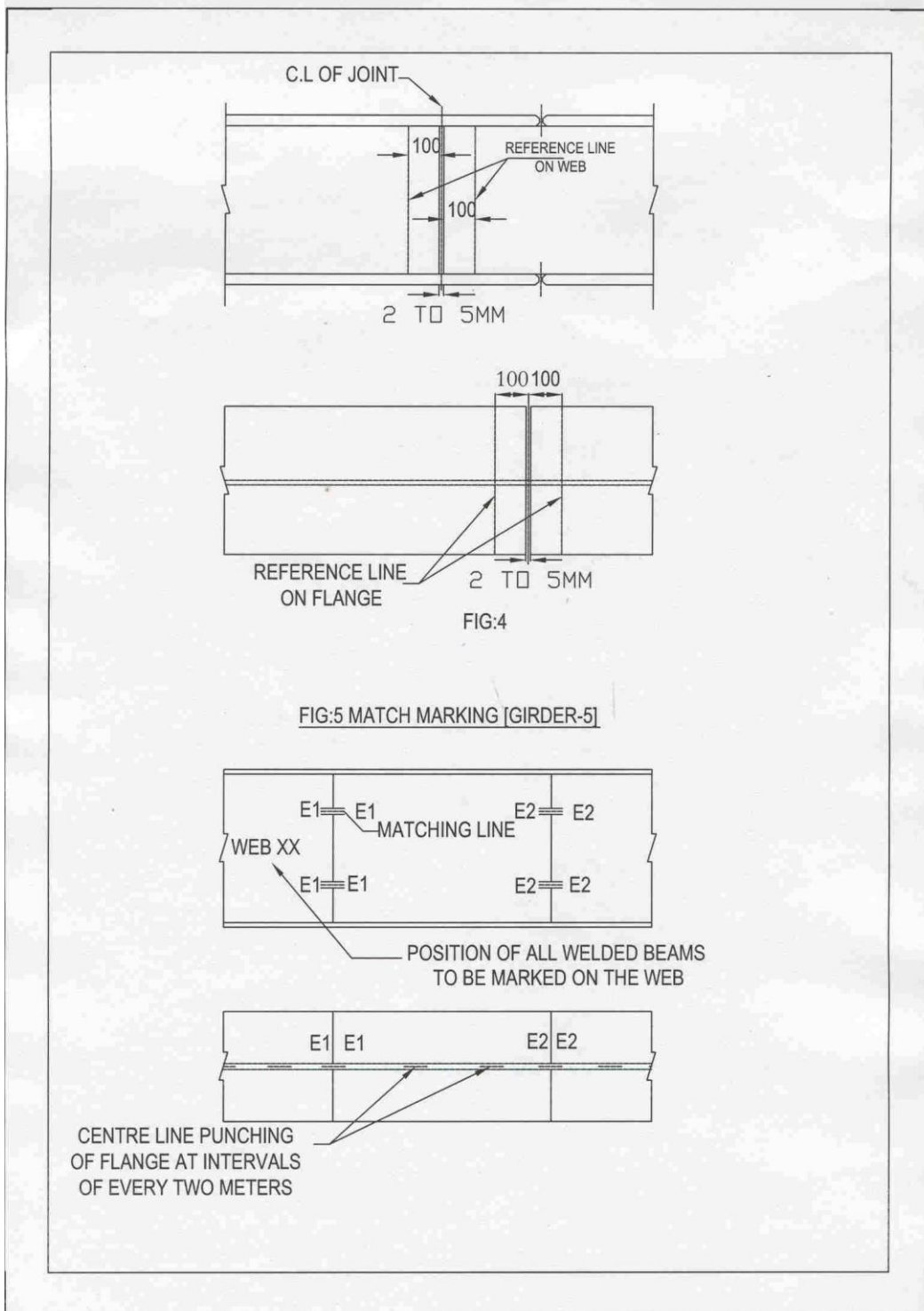

Place
Date

Signature of the Bidder
(NAME & ADDRESS WITH SEAL)



BHARAT HEAVY ELECTRICALS LIMITED

POWER PLANT PIPING UNIT

THIRUMAYAM- 622 507

CONTRACTS DEPARTMENT

Phone : 04333279551

E.mail : ilango@bheltry.co.in Website : www.bhel.com

Tender No:PPPU:WC:14:015

Tender Notice

Dt. 04.10.2014

DESIGNATION	DETAIL OF SKETCH	PERMISSIBLE DEVIATION
WEB SHIFT	<p>FIGURE-7</p>	$\frac{b1 - b2}{2} = 2\text{mm MAX}$
FLANGE WARPAGE	<p>FIGURE-8</p>	$T1+T2 = \frac{B}{100} \text{ OR } 6\text{MM}$
CAMBER	<p>FIGURE-9</p>	$E = 1/1000 \times \text{length}$ <p>SUBJECT TO MAX.] OF 10mm.</p>

Place
Date

Signature of the Bidder
(NAME & ADDRESS WITH SEAL)



BHARAT HEAVY ELECTRICALS LIMITED

POWER PLANT PIPING UNIT

THIRUMAYAM- 622 507

CONTRACTS DEPARTMENT

Phone : 04333279551

E.mail : ilango@bheltry.co.in Website : www.bhel.com

Tender No:PPPU:WC:14:015

Tender Notice

Dt. 04.10.2014

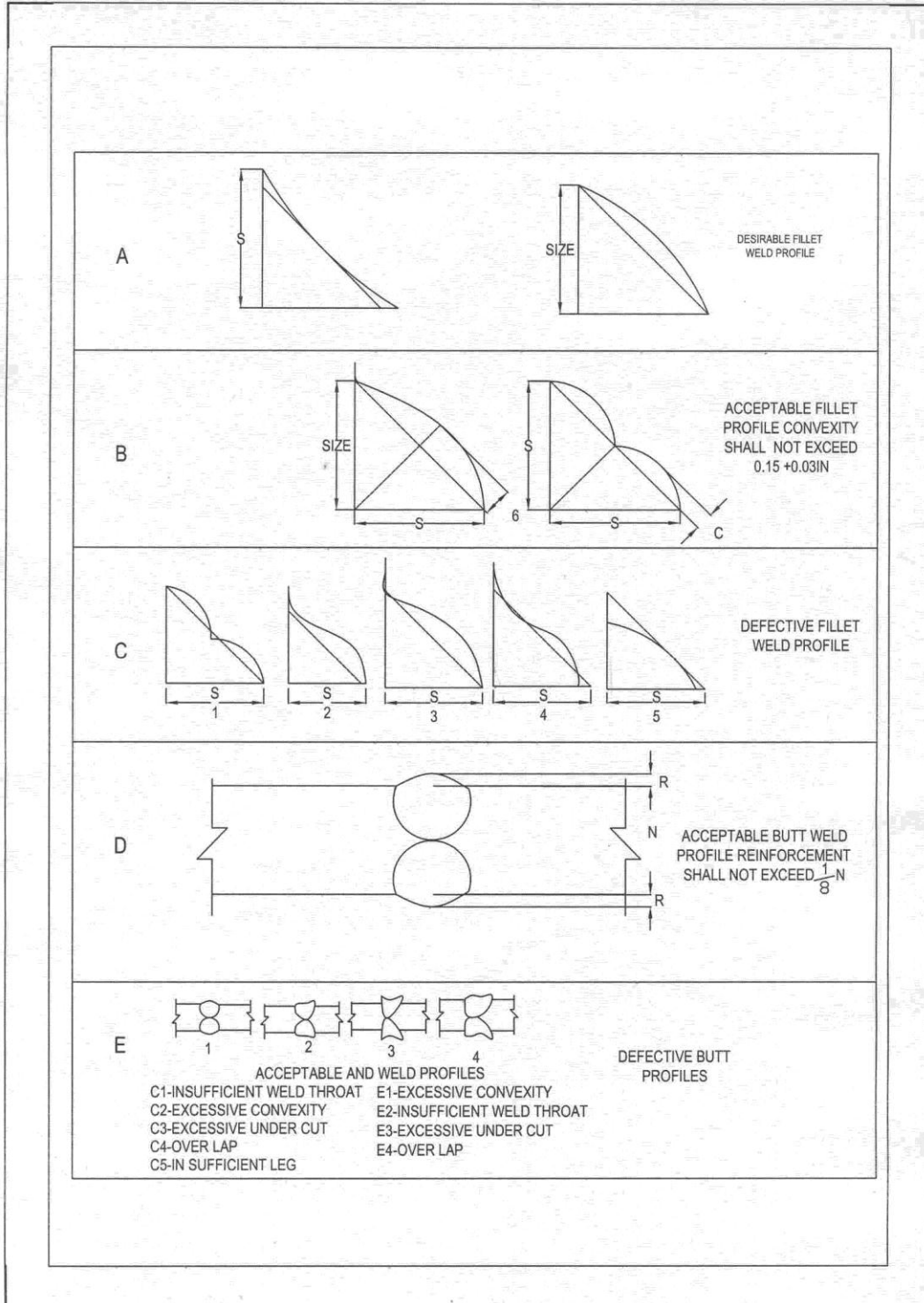

Place
Date

Signature of the Bidder
(NAME & ADDRESS WITH SEAL)



BHARAT HEAVY ELECTRICALS LIMITED

POWER PLANT PIPING UNIT

THIRUMAYAM- 622 507

CONTRACTS DEPARTMENT

Phone : 04333279551

E.mail : ilango@bheltry.co.in Website : www.bhel.com

Tender No:PPPU:WC:14:015

Tender Notice

Dt. 04.10.2014

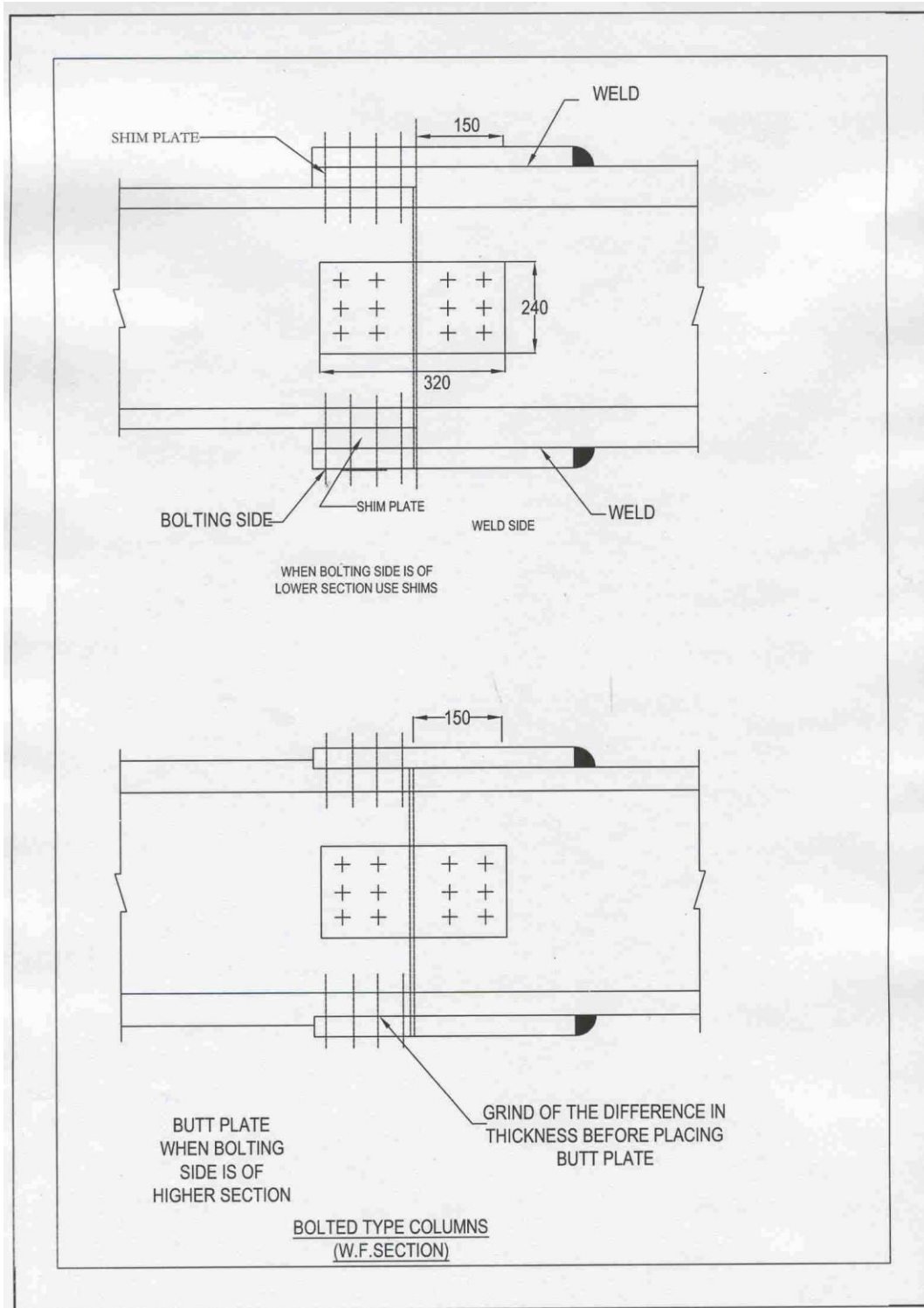

Place
Date

Signature of the Bidder
(NAME & ADDRESS WITH SEAL)



BHARAT HEAVY ELECTRICALS LIMITED

POWER PLANT PIPING UNIT

THIRUMAYAM- 622 507

CONTRACTS DEPARTMENT

Phone : 04333279551

E.mail : ilango@bheltry.co.in Website : www.bhel.com

Tender No:PPPU:WC:14:015

Tender Notice

Dt. 04.10.2014

CIVIL ENGINEERING DEPARTMENT WORK & SAFETY PROCEDURE

Place
Date

Signature of the Bidder
(NAME & ADDRESS WITH SEAL)



BHARAT HEAVY ELECTRICALS LIMITED

POWER PLANT PIPING UNIT

THIRUMAYAM- 622 507

CONTRACTS DEPARTMENT

Phone : 04333279551

E.mail : ilango@bheltry.co.in Website : www.bhel.com

Tender No:PPPU:WC:14:015

Tender Notice

Dt. 04.10.2014

TAMILNADU BUILDING PRACTICE (SPECIFICATION)

SPECIFICATION No. 16 (TNBP 46)

REMOVAL OF BUSHES, TREES, PRICKLY PEAR ETC.

1. The prickly pear shrubs, weeds and grass shall be cleared and roots shall be thoroughly grubbed up. These shall be disposed of in one of the ways specified below, as directed by the Executive Engineer.
 - 1.1 They may be removed to a convenient spot and shall be completely burnt :
 - 1.2 They may be buried in pits with atleast 30 cm. Depth of earth on the prickly pear at ground level. These pits may be dug in the bed of tank or at any place shown to him by the Officer deputed by the Executive Engineer.
2. Under no circumstances shall cleared stuff be thrown by the side of or heaped on existing vegetation, without one of the aforesaid steps being taken for its destruction.

SPECIFICATION No. 17

CLEARING AND LEVELLING SITE

1. The area described or shown on the relevant site plan shall be cleared of all obstruction, loose stones, non – required materials and rubbish of all kinds. All brushwood shall be cleared and the roots entirely grubbed up. No trees are to be cut down and removed without the instructions of the Executive Engineer. Those which are cut down shall be grubbed up. The same remarks apply to jungle clearance. Trees to be preserved will be defined in an addendum specification.
2. The products of the clearing are to be stacked in such place and manner as may be ordered by the Executing Engineer and the ground shall be left in a perfectly clean condition ; all products of the clearing shall be the property of Government and shall be disposed of as the Executing Engineer may direct.
3. All holes or hollows, whether originally existing or produced by digging up roots shall be carefully filled up with earth, well rammed and leveled off, as may be directed.
4. In the case of buildings, in order to clear cut white – ants, the whole area proposed to be occupied by the buildings, together with an extra width of 3 m. all round shall be excavated to a depth of 15 cm. And soaked with water. Spreading wet straw over the area bring the ants to the surface. If a white – ant’s nest exists on the site, its presence will become evident in a few days, whereupon the nest should be completely dug out, the queen ant destroyed and the nest flooded with boiling water containing a solution of arsenic. The area

Place
Date

Signature of the Bidder
(NAME & ADDRESS WITH SEAL)



BHARAT HEAVY ELECTRICALS LIMITED

POWER PLANT PIPING UNIT

THIRUMAYAM- 622 507

CONTRACTS DEPARTMENT

Phone : 04333279551

E.mail : ilango@bheltry.co.in Website : www.bhel.com

Tender No:PPPU:WC:14:015

Tender Notice

Dt. 04.10.2014

wherefrom the top loose has been removed shall be refilled with earth from a source approved by the Executing Engineer and properly leveled. It should be observed that no earth filling is to be done in cases where the holes dug to remove the white –ant’s nest go below the bottom of foundation level. Concrete filling will in such cases be done under the orders of the Executing Engineer and contractor will be paid for the extra quantity of concrete at his agreement rate for the same.

5. The contract rate for this item of work shall be for complete compliance with this specification. If any extra work is necessary under this heading, a separate arrangement will be made with the contractor, in writing, before the work begins.

SPECIFICATION No. 18

DISMANTLING BUILDINGS

1. The buildings or other structures defined in the schedule and handed over shall be dismantled down to ground level or to bottom of foundations or the posts, iron works, etc., which are specified shall be dug upto or below ground level, as may be specified in the schedule item wording.
2. Special care shall be taken that the materials are as little damaged as possible, in the process of dismantling. The value of materials broken or damaged through carelessness shall be recovered from the Contractor.
3. All serviceable materials shall be removed and stacked or disposed off as specified.
4. All mere rubbish shall be collected in heaps for disposal in the manner specified in the tender notice.
5. Method of payment will be defined in the tender notice and further supplementary specification regarding re-usage of useful material given for each case of such work

SPECIFICATION No. 19

INSTRUCTIONS TO CONTRACTORS ON BLASTING OPERATIONS

1. All contractors who execute blasting operations in connection with Public Works Department Works for purpose of quarrying stones, road construction, excavating foundations, well sinking or for any other purpose, shall observe the rules and precautions set forth below and any further additional instructions which may be given by the Public Works Department Officer in immediate charge of the work, and shall be responsible for any accident which may occur to workmen or the public due to such blasting operations. The sub – Divisional Officer should frequently check the Contractor’s compliance with the precautions.

NOTE : In cases where blasting is done departmentally without the services of a contractor (or piece-worker) the sub – Divisional officer shall himself see that all the precautions are observed.

2. Blasting with Powder

Place
Date

Signature of the Bidder
(NAME & ADDRESS WITH SEAL)



BHARAT HEAVY ELECTRICALS LIMITED

POWER PLANT PIPING UNIT

THIRUMAYAM- 622 507

CONTRACTS DEPARTMENT

Phone : 04333279551

E.mail : ilango@bheltry.co.in Website : www.bhel.com

Tender No:PPPU:WC:14:015

Tender Notice

Dt. 04.10.2014

2.1. Blasting operation must be in charge of competent persons appointed by the contractor and be carried out during fixed hours of the day, preferably during the mid-day lunch on hour or at the close of the work. No ignition of blasts shall be permitted by Contractor except in the presence and under the personal supervision of such competent person. The Sub-Divisional Officer should fix the hours in written orders.

2.2. The contractor shall be responsible for the safe custody and storage of powder, dynamite or other explosives bought for use on the work, and shall keep such explosives separate from the fuses and detonators until being actually placed in the blast holes.

2.3 Instructions contained in I.S. 4701 shall also apply.

3. Blasting with dynamite and other high explosives :

3.1.1. Paragraphs 2.1, 2.2 and 2.3 of the instructions for Blasting with powder shall apply.

3.1.2. The competent person appointed by the contractor to be responsible for directing blasting operations will be referred to as contractor's supervisor in these rules.

3.2 The position of all holes to be drilled must be marked out such white paint and the contractor's supervisor must take particular note of these positions.

3.3. The drilling operations being finished, the contractor's supervisor must take a second inspection, and satisfy himself that the bore hole marked out by him have been drilled

3.4. The Contractor's supervisor himself must prepare all charges necessary for the bore holes.

3.5. The contractor shall instruct his supervisor regarding the number of holes to be loaded and fired at one time. The number shall in no case be more than ten. The charges should be fired as far as practicable successively and simultaneously.

3.5.1. The loading is to be done by contractor's supervisor himself, and the position of the charge holes carefully noted.

3.6 Immediately before firing a blast, due warning must be given and the contractor's supervisor must see that all the coolies have retired to safety.

3.7 The safety fuses of the charged holes are to be lighted in the presence of the contractor's supervisor who must see that the fuses of all the holes charged have properly ignited.

3.8. Careful count must be kept by the contractor's supervisor and others, of each blast as it explodes.

3.9. After the blast, the contractor's supervisor must carefully inspect the work and satisfy himself that the full number of charged holes have exploded.

3.10.1. In case of misfired holes the contractor's supervisor must first examine the same and at once mark a red-cross over the holes

3.10.2. The contractor's supervisor should also at once report to the contractor and sub-divisional officer in charge of the work all cases of misfire, the cause of the same and what steps were taken in connection therewith.

Place
Date

Signature of the Bidder
(NAME & ADDRESS WITH SEAL)



BHARAT HEAVY ELECTRICALS LIMITED

POWER PLANT PIPING UNIT

THIRUMAYAM- 622 507

CONTRACTS DEPARTMENT

Phone : 04333279551

E.mail : ilango@bheltry.co.in Website : www.bhel.com

Tender No:PPPU:WC:14:015

Tender Notice

Dt. 04.10.2014

4. Precautions against misfire :

- 4.1. If a misfire has been found to be due to defective fuse detonators or dynamite, the whole quantity or box from which the defective article was taken must be returned to the office for inspector.
- 4.2. Instructions, contained I.S. 4081 0 1967 shall also apply.

5. Notes on Dynamite :

- 5.1. Blasting with Dynamite covered I.S. 4791 shall also apply
- 5.2. Tamping : Water, sand and clay are the best materials for tamping the first two being the easiest to use. Soft muram is also suitable. IF water is used, the junction of the fuse with detonator must be made water – tight. This can be done by means of coal – tar thickened with quicklime. A piece of cloth can then be wrapped round the joint and kept in position with a few turns of yarn. In case of a misfire with clay tamping , the old charge must not be removed but a fresh hole should be bored not less than 14 cm from the old one, loaded and fired in the usual way. The explosion of the charge in the new hole will almost always explode the first charge. Should the first hole be considerable depth, it will only be necessary to make the new whole 15 cm. Lower than the top of dynamite in the old hole.

6. Blasting operations :

- 6.1. Hard rock requiring blasting shall comprise of :
 - (i) any rock of cement concrete for the excavation of which the use of mechanical plant or blasting is required.
 - (ii) reinforced cement concrete (reinforcement cut through but not separated from the concrete) below ground level, and boulders requiring blasting .
- 6.2. The classification of hard rock requiring blasting shall be decided by the Executing Engineer and his decision shall be final and binding on the contractor. Merely the use of explosives in excavation will not be considered as a reason for higher classification unless blasting is clearly necessary in the opinion of the Executive Engineer.
- 6.3. All the excavated materials quarried, from the P.W.D. or other Government quarries shall be the property of Government. Where the excavated material is directed to be used in the construction of embankment, etc., it shall be directly deposited at the required location.
- 6.4. All other materials quarried, which are not intended for use in the work shall be stacked neatly for future use of Government land as directed by the Executive Engineer. Unsuitable and surplus materials not intended for use in any part of the work shall be disposed of as directed by the Executive Engineer.

7. Measurement :

Place
Date

Signature of the Bidder
(NAME & ADDRESS WITH SEAL)



BHARAT HEAVY ELECTRICALS LIMITED

POWER PLANT PIPING UNIT

THIRUMAYAM- 622 507

CONTRACTS DEPARTMENT

Phone : 04333279551

E.mail : ilango@bheltry.co.in Website : www.bhel.com

Tender No:PPPU:WC:14:015

Tender Notice

Dt. 04.10.2014

- 7.1. For rock excavation, the over burden shall be removed first so that necessary cross sections could be taken for measurement.
- 7.2. Where excavation is in trenches or from borrow pits in fairly uniform ground, the measurements of cutting in trenches or borrow pits shall be made.
- 7.3. Where the ground is not uniform, levels shall be taken before the start, after site clearance and after the completion of the work and the quantity of excavation in cutting is computed from these levels.
- 7.4. Where cross sectional measurements could not be taken due to irregular configuration, payments may be made for rock excavating on stack measurements after debuting 40 per cent for the quantity of voids.
- 7.5. The rate shall be per cum of rock blasted and computed on the basis described above.

EXTRACT FROM N.B.O.

Blasting and storage of explosives.

APPENDIX A

GENERAL

- 1.1. The manufacture, storage, transport and use of explosives all be covered by a license as required by the current rules and legislature in regard to storage and handling of explosives, Instructions given hereunder wherever they are repugnant to the requirements laid down by the Central and the State Governments, shall be deemed to have been superseded by these rules. All departments officials and the contractors in charge of the use and storage of explosives, shall acquaint themselves with the current rules legislation issued by the Government, and ensure that they are strictly complied with.
- 1.2. No child under 16 years of age and no person who in a state of intoxication, shall be employed on the loading, unloading or transport of explosives, or be employed in, or allowed to enter in premises where explosives are handled and / or stored
- 1.3. For issue of instructions on use of explosives, refer paragraph 3601 of the Indian Railways and Works Manual.

2. Carriage of explosive

- 2.1. For detailed instructions about carriage of explosives, reference should be made to the I.R.C.A. Red Tariff No. 18 for "Conveyance by rail, of explosive and other dangerous goods". Special attention is invited to the following sections in the Red Tariff : -

104.2	Powers to return to consignor
105.1	Pass required to accompany Consignments
106.1	Notice of dispatch compulsory
107.1.	Documents required
107.1 to 110.6	Packing
111.1 to 111.4	Marking and leveling
115	Handling

Place
Date

Signature of the Bidder
(NAME & ADDRESS WITH SEAL)



BHARAT HEAVY ELECTRICALS LIMITED

POWER PLANT PIPING UNIT

THIRUMAYAM- 622 507

CONTRACTS DEPARTMENT

Phone : 04333279551

E.mail : ilango@bheltry.co.in Website : www.bhel.com

Tender No:PPPU:WC:14:015

Tender Notice

Dt. 04.10.2014

115	Precautions
116	Storage
119 to 124	Trains by which dispatch is permission
124	Types of wagons and quantities permitted
125 and 126	Carriage in brake vans, passenger compartments, etc.

- 2.2. The transport of explosives by rail, ship or other public conveyance, is regulated by the rules framed by Government on the subject. The civil authorities should be contacted to obtain the rules in force.
- 2.3. Every consignment to or from a "Storage Magazine" must be accompanied by a Guard and a responsible person experienced in the handling of explosives.
- 2.4. Detonators and explosives are not to be conveyed in the same consignment. Inflammable materials such as matches, kerosene etc., are not to be carried in the same consignment with either explosives or detonators.
- 2.5. Before explosives are removed each case, barrel or package is to be carefully examined to ascertain that it is properly closed and shown no sign of leakage. Should any case, barrel or package, appear to be damaged or in a dangerous condition is to be removed separately and with special care.
- 2.6. Should any case, barrel or package, appear to be damaged or in a dangerous condition it is to be removed separately and with special care.
- 2.7. Cases containing dynamite should not be exposed to the sun, or allowed to get damp.
- 2.8. Where the weight of the explosives transported in any vehicle exceeds 900 kg. They shall be placed in the interior of the vehicles which shall be enclosed on all sides with wood or metal, so as to effectually protect the explosives from communication of fire and the vehicle shall be locked. When the weight of explosives does not exceed 900 kg. And unless they are carried in the manner laid down above, they must be completely covered with fire proofed cloth, tarpaulins or any other suitable material. So as to effectually protect explosives from communication of fire.
- 2.9. Explosives should not be moved during the thunder storm or dust storm.
- 2.10. No person except the driver should be allowed to travel on a vehicle conveying explosives, He shall not drive, conduct or maneuver the vehicle in a dangerous negligent manner.
- 2.11. No carriage or vessel shall be used for transporting explosives unless all iron or steel therein with which a package containing any explosives is likely to come in contact, is effectually covered with lead, leather, wood, cloth or other suitable material. No lights should be carried on the vehicle carrying the explosives.
- 2.12. No person is to be allowed to smoke or even to carry matches when accompanying a consignment of explosives.
- 2.13. No operation connected with loading, unloading and handling of explosives shall be conducted between sunset and sunrise.

Place
Date

Signature of the Bidder
(NAME & ADDRESS WITH SEAL)



BHARAT HEAVY ELECTRICALS LIMITED

POWER PLANT PIPING UNIT

THIRUMAYAM- 622 507

CONTRACTS DEPARTMENT

Phone : 04333279551

E.mail : ilango@bheltry.co.in Website : www.bhel.com

Tender No:PPPU:WC:14:015

Tender Notice

Dt. 04.10.2014

- 2.14. No explosives shall be brought to any place of loading until the carriage or vessel into which it is to be loaded, as at the place in readiness to receive it. A consignment of explosives should be conveyed direct without delay or unnecessary stoppage on the way.
- 2.15. In moving explosives, the cases should be carried or passed from hand to hand, not thrown dragged or dropped. Barrels are to be carried, not rolled.
When explosives are being put into or taken out from a storage magazine the men should be divided into two gangs, one working inside the magazine and the other outside; no persons from either gang being allowed to cross threshold while the work is going on .
- 2.17 The maximum quantity of explosives permitted to be carried by each consignment is fixed by the "Explosive Rules, 1940" as under -

- (i) 4500 kg. In any one Railway wagon
- (ii) 2700 Kg. In any one carriage other than a railway wagon
- (iii) 22,500 Kg. In any one boat

Custody and storage of explosives

- 3.1. The explosives shall not be stored anywhere but in a special magazine to be built for the purpose. The site of the magazine shall be fixed by the Engineer-in-charge in consultation with civil authorities according to the rules in force. Explosives must not be exposed to the sun but must always be kept under cover
- 3.2. Magazines may be considered as of two kinds viz., "Storage Magazines" and 'expense Magazines". The former may be in any convenient position but the latter should be near the site of the work on which the explosives are to be used.
- 3.3. A service supply shall be stored by the Supervisor in charge in an "express magazine" to be built at site according to the Government rules in force on the subject, and should if practicable be erected in such a position that in the event of an explosion neither the work nor the men employed on the same are likely to be affected, it must in no case be placed inside a tunnel mine or quarry.
- 3.4. For the site of a magazine, an isolated position should be selected a considerable distance from any town, railway station, or place of public resort, complying with the table of distance to be kept clear around explosive magazines, as per rules in force.
- 3.5. Under no circumstances should magazine be erected within 400 m of any working kiln or furnace, and similarly after a magazine has been constructed such operations as lime or charcoal burning could not be allowed within 400 m of the magazine.
- 3.6. The site for a magazine should, if practicable, be so arranged that in the event of explosion, any neighbouring town, station or other place of public resort, would be sheltered by intervening high ground. Where the natural surface of the ground is not shifted to this arrangement, a thick belt of tress may sometimes be utilised as a screen. An artificial shelter may also be made by surrounding the magazine, by a bank of earth as high as the eaves of the magazine. When this arrangement is adopted care must be taken that proper provision is made for drainage, and the slopes of the bank towards the magazine should be as easy as practicable.
- 3.7. The space surrounding the magazine should be fenced in. The ground inside this fence should be kept clear and free from tress, bushes, etc., the admission to this fenced space

Place
Date

Signature of the Bidder
(NAME & ADDRESS WITH SEAL)



BHARAT HEAVY ELECTRICALS LIMITED

POWER PLANT PIPING UNIT

THIRUMAYAM- 622 507

CONTRACTS DEPARTMENT

Phone : 04333279551

E.mail : ilango@bheltry.co.in Website : www.bhel.com

Tender No:PPPU:WC:14:015

Tender Notice

Dt. 04.10.2014

- should be by one gate only and no person should be allowed inside this fence, without permission of the officer in-charge. In the case of "Storage Magazine" the clear space between the fence and the Magazine should nowhere be less than 100m.
- 3.8 The door of magazine should be sheltered by a screen wall or other erection so arranged as to protect the doorway from direct bullet fire. The door and its fastenings should be strong enough to resist forcible entry, and should preferably be a thick wooden one, faced on the outside with plate iron about 6 mm. Thick and opening outwards. The window should be of the same construction. All fittings and keys should be of brass or gun metal (not iron). The door should be fastened with two separate locks, the key of one being kept by the guard and the key of the other by the officer – in – charge.
- 3.9 The roof of the magazine should be arched, and where considered desirable, may be made bomb proof by thick covering earth above arch. Timber should not be used in the construction of either the walls or the roof.
- 3.10 Two thoroughly efficient lightning conductors should be provided to the magazine, one at each end. The lightning conductors shall be tested at least once every year.
- 3.11 Ventilators should be provided, and so designed as to secure good ventilation, but not admit of the insertion of man's arm or any article being passed through them from outside. They should be protected by a grating on the outside and be fitted inside with copper wire gauze.
- 3.12 Every magazine should be perfectly well-drained
- 3.13 No iron or steel is to be used in a magazine for nails, fastenings, fittings or any other purpose.
- 3.14 The interior of the magazine, that is, the floor and walls, should be plastered smooth with cement. This is preferable to lining them with wood, which attacked by insects and creates dust.
The magazine should at all times be kept scrupulously clean. High explosives like dynamite should be stored in a dry, clean well – ventilated, bullet proof and the fire proof building, on an isolated site.
- 3.15. No one shall enter a magazine except in the presence of the Officer-in-charge, with his permission. The person in charge of the magazine is to take care that the magazine is well and securely locked.
- 3.16. Magazine shoes without nails should be kept at all time in the magazine, and a wood tub or cement trough about 30 cm, high and 45 cm. In diameter, filled with water should be fixed near the door of the magazine.
Persons entering the magazine must put on the magazine shoes provided for the purpose and be careful.
(a) Not to put their feet on the clean floor unless they have the magazine shoes on :
(b) Not to allow the magazine shoes to touch the ground outside the clean floor :
(c) Not to allow any dirt or grit to fall on the clean floor
- Persons with bare foot will, before entering the magazine, dip their feet in water, and then step direct from the tub over the barrier (if there is one) on to the clean floor.
- 3.17. A brush or broom should be kept in the lobby of the magazine for cleaning on each occasion it is opened, for the receipt, delivery on inspection of explosive.

Place
Date

Signature of the Bidder
(NAME & ADDRESS WITH SEAL)



BHARAT HEAVY ELECTRICALS LIMITED

POWER PLANT PIPING UNIT

THIRUMAYAM- 622 507

CONTRACTS DEPARTMENT

Phone : 04333279551

E.mail : ilango@bheltry.co.in Website : www.bhel.com

Tender No:PPPU:WC:14:015

Tender Notice

Dt. 04.10.2014

- 3.18. No matches or inflammable materials should be allowed in a magazine.
- 3.19. No person having articles of steel or iron on him is to be allowed to enter the magazine. Workmen or any other persons any admitted into the magazine should not have on their person any articles mentioned in paragraphs 3-18,3-19, and 3-0.
- 3.20. Oily cotton rags, waste and articles liable to spontaneous ignition, should not be taken into the magazine.
- 3.21. No tools or implements other than those of copper, brass gunmetal or wood should be allowed inside the magazine. Tools should only be used with great gentleness and care/
- 3.22. A guard should be provided to every magazine for its safe custody. The strength of the guard should be settled by the Engineer in consultation with the civil authorities.
- 3.23. Detonators, for signals, fuses etc., are not to be kept in the same magazine with gun-powder, dynamite or other explosives. Detonators can however be kept in an annex adjoining the magazine provided that their number does not exceed 25,000 and that the annex is so constructed that not less than 60 cm of masonry and 100 cm of air space shall intervene between any detonators in such annex and the interior of the main magazine.
- 3.24. Barrels or cases containing explosives are not to be opened in a magazine. Explosives in open cases are not to be received into a magazine.
- 3.25. Explosives which appear to be in a damaged or dangerous condition are not to be kept in any magazine, but must be removed without delay to a safe distance and destroyed. Any necessary destruction of explosives such as might be required owing to deterioration of the explosives or exudation of nitroglycerine, should be carried out in accordance with the instructions given by the Engineer in-charge.
- 3.26. Artificial light is not to be allowed in any magazine. Electric storage battery torches may however be allowed.
- 3.27. No smoking shall be allowed within 100 m of a magazine.
- 3.28. In "Expense Magazines" the mallets, levers, wedges, etc., for opening barrels or cases are to be of wood. Tools should only be used with great gentleness and care.
- 3.29. Packing or unpacking, or any operation involving the moving of explosives among one another in an opened case, is not to be permitted in a magazine.
- 3.30. Barrels or cases to moved in a magazine are to be carried by hand, not rolled, dragged, or turned over and over on the floor.
- 3.31. No person is to be allowed to sleep, to take food, or to loiter in a magazine.
- 3.32. Should repairs or alteration be necessary in a magazine every precaution should be taken, and if practicable, the officer in-charge should be present while the work is in progress.
- 3.33. Account should kept in every magazine of all explosive received and issued.
- 3.34. Barrels and cases are to be properly labeled to indicate the nature of the contents, quantity, date of receipt, from whom received, and other particulars, so that their history can be traced.
- 3.35. Explosives which have been issued and returned to the magazine are to be issued first ; otherwise those which have been longest in store are to be first issued.
- 3.36. The quantity of explosives allowed to be kept in an "Expense magazine" should be limited, and a notification defining that limit should be posted up in a conspicuous position, both inside and outside the magazine.

Place
Date

Signature of the Bidder
(NAME & ADDRESS WITH SEAL)



BHARAT HEAVY ELECTRICALS LIMITED

POWER PLANT PIPING UNIT

THIRUMAYAM- 622 507

CONTRACTS DEPARTMENT

Phone : 04333279551

E.mail : ilango@bheltry.co.in Website : www.bhel.com

Tender No:PPPU:WC:14:015

Tender Notice

Dt. 04.10.2014

- 3.37. Barrels and cases must be kept clear of the walls and floors so as to allow the air to circulate freely on all sides. It is recommended that where practicable, they should be stacked in the middle with a clear space all round.
- 3.38. Neatness and order in arrangements of a magazine are to be strictly enforced. No dirt or rubbish is to be allowed, and special care is to be taken to keep the floor free from grains of powder or portions of explosive matter fall on the floors due to leakage of cases, etc.
- 3.39. A brush or broom should be kept in the magazine or in the lobby if there is one, for cleaning out the magazine on each occasions it is opened for the receipt, delivery or inspection of the explosives.
- 3.40. Magazine should be opened occasionally in dry weather, so as to keep them well aired. When open they are to be carefully guarded.
- 3.41. The ventilators of a magazine are to be closed during a dust storm or thunder storm, and the magazine is not to be opened during the prevalence of an atmospheric disturbance of this nature, not should any person be allowed in the vicinity of the magazine.
- 3.42. Should there be a difficulty in keeping the magazines free from damp, freshly burnt quick lime, exposed in wooden trays recommended to be kept in the magazines.
- 3.43. In every "storage magazine" a maxima and minima thermometer should be put up in a suitable position, and a note of the temperature recorded by each instrument should be made at regular intervals not exceeding a week. It is recommended that this be also done in an "expense magazine".
- 3.44. A record should be kept of all occasions on which a "storage magazine" is opened, with such particulars as may appear desirable.
- 3.45. All magazines are to be officially inspected at definite intervals and a record kept of the results of such inspections.
- 3.46. At each inspection, the conditions of the lightning conductors should be carefully examined. The lightning conductors have to be got tested once every year by an Inspector of Explosives in the manner prescribed by the Chief Inspector of Explosives, and a certificate showing the result and date of test obtained from him on payment of requisite fee, shall be hung up in the magazine in a conspicuous place.
- 3.47. The rules in force in each magazine should be printed in clear type and hung up in a conspicuous position both in and outside the building. The officer-in-charge of the magazine should be responsible to ensure that the rules are strictly observed.
- 3.48. When high explosives are stored, a sample should be taken atleast once a year and forwarded to the nearest chemical examiner for test. High explosives are those which are habitually fixed by detonation, and used where a destructive rather than a propellant effect is aimed at, and include such explosives as :
Blasting gelatine, carbonite, celitite, dynamic, geignite, monober powder, phoenix powder, Negro powder, reburite, tenite ammonal, gun cotton slab, picric acid, tri-nitro-to- vol (TNT), etc.
An adequate slot must be cut on the side of the plug to hold the fuse, and prevent it from damage when the plug is being tapped down. The top of the plug should be painted red.

Use of Explosives

Place
Date

Signature of the Bidder
(NAME & ADDRESS WITH SEAL)



BHARAT HEAVY ELECTRICALS LIMITED

POWER PLANT PIPING UNIT

THIRUMAYAM- 622 507

CONTRACTS DEPARTMENT

Phone : 04333279551

E.mail : ilango@bheltry.co.in Website : www.bhel.com

Tender No:PPPU:WC:14:015

Tender Notice

Dt. 04.10.2014

- 4.1. The explosive shall not be used on the works or on the site by the contractors without the written permission of the Engineer-in-charge.
- 4.2. Blasting shall only be carried out at certain specified times to be jointly agreed to by the contractor and the Engineer-in-charge within the hours of day specified by the licensing authorities, and an area of 200 m radius from the firing point is to be specially flagged out, and all workmen excluded there from atleast 10 minutes before the hour for firing, a warning bell being sounded for the purpose.
- 4.3. Explosives shall not be brought on to the works in quantities exceeding the amount enough for the particular amount of firing to be done and any surplus explosive left, when all the holes have been charged, must be carefully removed at least 300 m away from the firing point.
- 4.4. A properly appointed agent on behalf of the contractor shall personally superintend the firing, and not more than eight holes at a time shall be sent off (fired successively and not simultaneous). Account shall be kept of the blasts : if these do not tally with the number fired, the difference indicates misfires, in which case no person shall be allowed to return to the site of the firing for at least half an hour after firing, when the misfire shall be carefully looked for by the authority's agent. In the event of misfire, a portion of tamping may be sludged out with compressed air or water under pressure, but no kind of tool shall be used for this purpose. The hole shall thereafter be reprimed and fixed. If a reliving hole shall run parallel to the misfired hole. If a misfired is detected during working hours and it is necessary to leave it charged till firing time, a sludge of red paint must be cut and around the drill hole.
- 4.5. If misfire has been found to be due to defective fuse, detonators or explosives, special notice should be sent to the officer-in-charge of the works, and to the persons in charge of the storage and "expense magazines". So that steps may be taken to inspect the whole quantity or box from which the defective article was taken. No more of the defective stock is to be used without permission of the Engineer-in charge
- 4.6. As each hole is drilled and loaded, a small wooden plug (not more than 8 cm.in length). Is to be driven in at the top, confining the fuse and also helping to indicate the position of the hole if it misfires. An adequate slot must be cut on the side of the plug to hold the fuse, and prevent it from damage when the plug is being tapped down. The top of the plug should be painted red.
- 4.7. Dynamite should be kept dry until used. If exposed to damp, the nitroglycerine exudes and becomes most dangerous. It shall not be exposed to direct rays of the sun, also it becomes highly dangerous if placed near fires, stoves, steam pipes or heated metal.
- 4.8. Frozen dynamite is a most dangerous substance, as simple friction of the crystals of nitro-glycerine due to rough or careless handling, dropping a cartridge or any sudden jolt ore jar is liable to cause detonation. None but the most experienced men should therefore handle it in a frozen state. It should be thawed by placing the cartridges in a pan floating in warm water.
 - 4.8.1.1.1. (i) A wooden tamping rod should be used to push the cartridge home. No metal rod or rammer shall be used in tamping or brought to the site of blasting work.
 - (ii) The charge should not be rammed or pounded but pressed firmly into place.
 - (iii) Dry earth should be used for tamping. If water is used, great care should be taken to press the cartridges into contact with each other, as water coming in

Place
Date

Signature of the Bidder
(NAME & ADDRESS WITH SEAL)



BHARAT HEAVY ELECTRICALS LIMITED

POWER PLANT PIPING UNIT

THIRUMAYAM- 622 507

CONTRACTS DEPARTMENT

Phone : 04333279551

E.mail : ilango@bheltry.co.in Website : www.bhel.com

Tender No:PPPU:WC:14:015

Tender Notice

Dt. 04.10.2014

between two cartridges will prevent the explosion of the lower one, and lead to a hold being only partially blown out and remaining charged with the balance of the dynamite.

4.9. The dynamite is exploded by means of a detonator pinched in to a fuse by means of special nippers, and put into the primer or cartridge. Instructions accompany each box and these should be carefully adhered to.

4.10.All fuses must be cut to the lengths required before being inserted into the holes.

4.11.Any slackness, carelessness or the infringement of the rule will render all responsible parties liable to prosecution.

4.12.Further detailed instructions for blasting operations are given in standard specification

Rules for opening an closing boxes of dynamite and blasting gelatin:

5.1. Wooden wedges, about 15 cm. Long 3 cm, thick at the head and 8 cm. Wide, also a small wooden mallet, weighting about 0.70 kg, and a wooden lever 60 cm, long x 5 cm. Wide x 2.5 cm, thick should be provided as the tools for opening boxes.

5.2. The boxes should be opened on a wooden table or plank, free from grit or metal nails.

5.3. To open the box, the lid should be forced up by inserting two wooden wedges in the end, and driving them in by the wooden mallet. When raised sufficiently, the wooden lever should be inserted and the lid prized off. After removing the lid, the water proof lining at the joint should be rent open, when the packets containing the cartridges will be accessible for taking out.

5.4. To re-close the box, all the brass nails should be first with drawn from the lid, the lid replaced in its proper position, and nailed with a wooden mallet.

5.5. Metal tools shall not under any circumstances be used for opening or re-closing : -
Account of explosives

6.1.1. To prevent explosives being disposed off unlawfully, following order must be strictly enforced :

(i) The superior in charge of the work shall personally responsible for all explosives, and shall personally attend to the charging, tamping and firing of all holes.

(ii) The supervisor in charge shall maintain a register in which the explosives used each day will be entered regularly the same evening, and copy of the entry shall be forwarded to the Engineer- in – Charge and IN ADDITION, A STATEMENT AT THE END OF EACH MONTH SHOULD BE PREPARED AND SENT TO THE ENGINEER-IN-CHARGE.

(iii) The Engineer – in – Charge shall personally check the balance once a quarter

Place
Date

Signature of the Bidder
(NAME &ADDRESS WITH SEAL)



BHARAT HEAVY ELECTRICALS LIMITED

POWER PLANT PIPING UNIT

THIRUMAYAM- 622 507

CONTRACTS DEPARTMENT

Phone : 04333279551

E.mail : ilango@bheltry.co.in Website : www.bhel.com

Tender No:PPPU:WC:14:015

Tender Notice

Dt. 04.10.2014

6.2.1. The Engineer-in-Charge shall be responsible for implicit compliance with the instructions herein given and with such as may emanate from Government from time to time, with regard to the storage and use of such explosives on the work.

6.2.2. All losses, shortage of stock and thefts of explosives, shall be reported without delay to the nearest Police Station.

Code of practice for earth work on canals.

APPENDIX – B

TYPICAL METHODS OF DRILLING AND BLASTING ROCK IN EXCAVATION

B-3. Blasting with powder

B – 3.1. In case of blasting with powder bore holes will be jumped or drilled into the rock face. The direction and spacing of the holes are very important for efficiency and economy. The line of least resistance (that is the distance of the bulk of the powder from the nearest rock face) must never be in the direction of the hole bored. The depth of the bore hole should be about the same as the line of the least resistance

B-3.2. The bore holes shall be dried before being charged. The powder shall be enclosed in a waterproof cartridge and introduced into each bore hole by a funnel or a copper tube. Safety fuses shall then be passed into the powder and taken outside to the required distance.

B-3.3. A wadding of hay or dry turf shall be placed on the powder and around the fuse. An inch or two of the wadding shall be pressed down on the powder and the remainder of the hole shall be filled in with tamping materials, that is , dry clay. The filling material shall be rammed or tamped with a copper or brass rod until it becomes compact. Care shall be taken to avoid any possibility of an air hole around the fuse.

B-3.4. The charge shall be fired by lighting the fuse. Fuses shall be cut to the required length before being inserted into the bore holes. Joints in fuses shall be avoided. Where they are necessary a semicircular niche shall be cut in each fuse about one inch from the end and the two pieces shall be superimposed and bound together with the string. All joints exposed to damp shall be wrapped with a rubber tape.

B-3.5 The number of blasts to be fired and the actual number of shots heard shall be compared and person responsible shall satisfy himself by examination that all the blasts have exploded before workers are permitted to approach the same. The withdrawal of the charge which has to exploded is under no circumstances to be permitted. The charge shall be flooded with water and the hole marked in a distinguishing manner. Another hole shall be jumped at a distance of about 50 cm. Of the old hole and fired in the usual way. The results shall be carefully examined by the persons in charge of blasting and the operations continued until the original blast is exploded.

B-4. Blasting with dynamite

Place
Date

Signature of the Bidder
(NAME & ADDRESS WITH SEAL)



BHARAT HEAVY ELECTRICALS LIMITED

POWER PLANT PIPING UNIT

THIRUMAYAM- 622 507

CONTRACTS DEPARTMENT

Phone : 04333279551

E.mail : ilango@bheltry.co.in Website : www.bhel.com

Tender No:PPPU:WC:14:015

Tender Notice

Dt. 04.10.2014

B-4.1. Dynamite is procurable, made up in cartridges of two kinds, one 22.2 mm. Diameter, 88.9 mm. Long, weighing 56.7 g, the other 25.4 mm. Diameter, 88.9 mm. Long, weighing 66.1g.

B-4.2. Dynamite is exploded by means of detonators. These are procurable in tin boxes and are laid in saw dust which should be blown out with a dry blow of the mouth before using. One end (cut square) of a Bickford's fuse is pushed into the detonator, till it touches the white fulminate within it. The open end of the cap is then pinched in with pincers to attach it to the fuse, care being taken not to break the powder cone of the fuse by pinching too tightly. If the detonator is to be used to damp or wet places the junction should be made watertight with grease, white lead or tar. A primer is then opened and the cap gently pushed up to its head into the dynamite, care being taken not to bury the detonator entirely. The paper of the primer is then closed up and securely bound with wire or twine to prevent displacement of the cap.

B-4.3. One cartridge is first placed in the bore hole and pressed not rammed down with a wooden hammer, never with an iron or metal rod, so as to form a proper contact with the sides of a rock, other cartridges are then added as may be required to make up the necessary charge. The primer is then gently pushed, not rammed down on the top of the charge. The space for about 20 cm. Above the charge is then gently filled with dry clay pressed home and the rest of the tamping is formed of any convenient material gently paced with a wooden rammer.

B-4.4. Following general principles should be followed in case of blasting rock with dynamite . the mode of proceeding is very much the same as for powder, but the holes of similar depth should be rather apart but will have smaller diameter. Continuity of circuit shall be checked with galvanometers so that all the detonators are correctly connected before blasting.

B-4.5. The following are the diameters of drills used for different depth of drills used for different depths of bore holes : -

Depth. m	Drill Diameter mm
1 to 2	25.4
2 to 3	38.1 to 50.8
3 to 4.5	50.8 to 63.5

B-4.6. The depth of bore hole should be about the same as the line of least resistance and if possible the bottom of the hole should never descend below the face of the rock. The bore holes should generally be not more than 1.5 m deep and their distance apart should be from one and half to two times their depth.

B-4.6.1. If the required charge is so great that it cannot be held in a holes should be made close together, the total charge being slightly increased and exploded simultaneously. By using delay detonators over cutting and undercutting can be minimized.

Place
Date

Signature of the Bidder
(NAME & ADDRESS WITH SEAL)



BHARAT HEAVY ELECTRICALS LIMITED

POWER PLANT PIPING UNIT

THIRUMAYAM- 622 507

CONTRACTS DEPARTMENT

Phone : 04333279551

E.mail : ilango@bheltry.co.in Website : www.bhel.com

Tender No:PPPU:WC:14:015

Tender Notice

Dt. 04.10.2014

B-4.7. Cracks and fissures in the rock to be blasted should be carefully studied to ascertain the best position for bore holes. The charge should always be placed in a sound piece of rock and if possible not nearer to a crack than 30 cm. If it is desired to shatter rock, close connections between the dynamite and the rock is essential and the points of contact should be multiplied as much as possible. For this reason several bore holes of moderate diameters are preferable to one hole of a larger diameter. Sometimes by having sloping holes s excavation can be controlled in a particular direction.

B-4.8. In case of gently sloping rock with no face, dynamite should be used as powder is to be used, only with fewer and shall power bore holes. As the line of least resistance is not so important in dynamite as in powder the necessity for sloping the holes is not so great. But, if a face is required on an almost level rock sloping holes should be used.

Safety code for blasting and related drilling operations

2.0. For the purpose of this standard, the following definitions shall apply.

2.1. Blasting cap – A shell closed at one end and containing a charge of detonating compound, which is ignited from a spark it is used for detonating explosives.

2.2. Detonator – The term shell include igniters, blasting caps, electric blasting caps, or other similar devices used to explode commercial explosives.

2.3. Electric blasting cap – A shall containing a charge of detonating compound which is ignited by an electric current from two projecting insulated leg wires.

2.4. Explosive - Any mixture or chemical compound which is capable of producing an explosion by its own energy. This includes black powder, dynamite, nitroglycerine compounds, fulminate, or explosive substance having explosive powder equal to or greater than black powder.

2.5. Magazine – Any building or other structure used for the storage of explosives.

2.6. Missed hole – A drilled hole containing an explosive charge that failed to explode

2.7. Permanent blasting wires – Those wires between the firing switches ; for use in blasting where the power source is an electric circuit.

2.8. Primer : An explosive cartridge with a detonator or igniting agent inserted therein.

2.9. Safety fuse : - A medium manufactured especially for firing explosive charges, that conveys a flame at uniform rate rather than one that is in itself a detonator or one that operates on some other principle

2.10. Stemming – Means material used for confirming a charge of explosives in a hole or to cover explosives in mud capping.

3. Transportation of explosives

3.1. All the relevant central state and local laws and rules and regulations if any, framed thereunder shall be complied with loading, unloading and handling of explosives will be supervised by qualified personnel.

Place
Date

Signature of the Bidder
(NAME & ADDRESS WITH SEAL)



BHARAT HEAVY ELECTRICALS LIMITED

POWER PLANT PIPING UNIT

THIRUMAYAM- 622 507

CONTRACTS DEPARTMENT

Phone : 04333279551

E.mail : ilango@bheltry.co.in Website : www.bhel.com

Tender No:PPPU:WC:14:015

Tender Notice

Dt. 04.10.2014

- 3.2. Where the magazine is located near the construction site and blasting operations continue daily, actual requirement of explosives shall be drawn from the magazine and transported to ,,,the site. Any left over should be returned back to the magazine each time after the blast. In case of work at scattered places and for a small duration, portable magazine shall be used and kept within a fence in a safe place and properly guarded.
- 3.3. For carrying small quantity (approximately 5 kg. Of explosives) specially designed insulated containers may be used. These containers shall be constructed of finished wood not less than 5 cm thick or plastic not less than 6mm. Thick or pressed fiber not less than 10 mm. thick. There shall be no metal parts (not even nails bolts, screws, etc.) and the container shall be water proof and provided with a lid. The containers shall be provided with suitable non-conductive carrying device, such as rubber , leather or canvas handle or strap.
- 3.4. Vehicles to be used for transporting explosives shall be in good working condition and shall have a tight wooden or non-sparking metal (copper, brass and the like) floor with sides and ends high enough to prevent the explosives from falling off the vehicle. In open – bodied vehicles, the explosives shall be covered with a water proof and fire-resistant tarpaulin.
- 3.5. Electrical wiring in vehicle shall be fully insulated so as to prevent the danger of short circuiting and atleast two fire extinguishers of carbon tetra chloride type shall be carried. The vehicle shall be properly marked so as to give adequate warning to the public in regard to the nature of cargo.
- 3.6. No metals except approved metal truck bodies shall be allowed to come in contact with cases of explosives. Metal ,flammable or corrosive substances shall not be transported with explosives, as far as possible, transportation of any other material along with explosives shall be prohibited.
- 3.7. Smoking shall be prohibited in the vehicle carrying explosives.
- 3.8. No un authorised person shall be allowed in the vehicle carrying explosives.
- 3.9. Loading and unloading of explosives shall be done carefully.
- 3.10.Explosives and detonators or blasting caps should not be permitted to be transported in the same vehicles.
- 3.11.Detonators and to the site of work in the original containers or in securely locked separate non-metallic container and shall not be carried loose or mixed with other materials.

4. Storage of explosives-

- 4.1 Storage of explosives is registered by the Indian Explosives act and provision thereunder should be strictly observed.
- 4.2 Explosives shall be stored only in a magazine which is clean dry, well ventilated, reasonably cool, correctly located, substantially constructed, bullet and fire resistant and securely locked.
- 4.3 Blasting caps, electric blasting caps or primers shall not be stored in the same box, container or room with other explosives.
- 4.4 Explosives, fuse or fuse lighters shall not be stored in a damp or wet place or near oil, gasoline, cleaning solutions or solvents or near radiators, steam pipes, or other sources of heat.
- 4.5 Smoking shall not be permitted within the fencing around the explosive magazine, nor matches, open lights, or other fire or flame shall be allowed near the magazine. Warning notice to this effect should be pasted at conspicuous places.

Place
Date

Signature of the Bidder
(NAME & ADDRESS WITH SEAL)



BHARAT HEAVY ELECTRICALS LIMITED

POWER PLANT PIPING UNIT

THIRUMAYAM- 622 507

CONTRACTS DEPARTMENT

Phone : 04333279551

E.mail : ilango@bheltry.co.in Website : www.bhel.com

Tender No:PPPU:WC:14:015

Tender Notice

Dt. 04.10.2014

- 4.6 No leaves, grass, brush or debris of any kind shall be allowed to accumulate within 8m of an explosive magazine.
- 4.7 No sparking metal or sparking metal tools shall be stored in an explosives magazine. Persons entering the magazine shall not have shoes with iron nails or other sparking metal.
- 4.8 If nitroglycerine from deteriorated explosives has leaked down on to the floor of the explosive magazine, the floor shall be desensitized by washing thoroughly with an agent obtained before hand from the supplier of the explosives. For this purpose, desensitizing agents and the instructions for using them shall always be obtained along with the supply of nitroglycerine.

5. Use of explosives

- 5.1. Precautions against lightning shall be provided in accordance with Indian Electricity Act and India Explosives Act and Rules and regulations framed thereunder.
- 5.2. Any package containing explosives shall not be dragged dropped or handled roughly. The explosives packages shall be opened only at a safe distance and properly shielded from the packages of explosives in bulk storage.
- 5.3. Sparking metal tools shall not be used to open legs or wooden or fiber board cases of explosives.
- 5.4. Smoking shall not be permitted nor matches, open lights, fire, flame, or any other device capable of producing sparks or flame shall be carried while handling or using explosives
- 5.5. Explosives shall not be placed where they may be exposed to flame excessive heat, sparks or impact.
- 5.6. The covers of the explosive cases or packages shall be replaced every time soon after taking out part of the contents as long as any explosives are left in them
- 5.7. Explosives shall not be carried in the pockets of any clothing or elsewhere on any person.
- 5.8. Primers shall not be made up in a magazine, or near excessive quantity of explosives, or in excess of immediate needs
- 5.9. Nothing shall be inserted in the open end of a blasting cap except fuses.
- 5.10.No person shall strike, tamper with, or attempt to remove or investigate the contents of a blasting cap or an electric blasting cap or attempt to pull out the crimped safety fuse cut of a blasting cap.
- 5.11.Children, unauthorised or unnecessary persons shall not be present where explosives are being handled or used.
- 5.12.No person shall handle, user or be near explosives during the approach or progress of any electrical storm. All persons shall retire to a place of safety.
- 5.13.Deteriorated or damaged explosive or blasting equipment shall not be used, but shall be disposed of as stated in 11.
- 5.14.No attempt shall be made to reclaim or use fuses, blasting caps, electric blasting caps or any other explosives which have been water soaked, even if they have been dried out. The manufacturers shall be consulted.
- 5.15.No. attempt shall be made to often hard set explosives by heating over a fire or by rolling the explosive on the ground.

Place
Date

Signature of the Bidder
(NAME & ADDRESS WITH SEAL)



BHARAT HEAVY ELECTRICALS LIMITED

POWER PLANT PIPING UNIT

THIRUMAYAM- 622 507

CONTRACTS DEPARTMENT

Phone : 04333279551

E.mail : ilango@bheltry.co.in Website : www.bhel.com

Tender No:PPPU:WC:14:015

Tender Notice

Dt. 04.10.2014

6. Drilling and loading

- 6.1. Before planning out the drilling operations for blasting purposes, nature of stratum and the over burden should necessarily be examined to avoid possibilities of land slides after blasting.
- 6.2 The face of rock shall be carefully examined before drilling to determine the possible presence of unfired explosive. No attempt shall be made to drill at a site if un detonated explosives are suspected and action shall be taken according to 10.4.
- 6.3. The bore hole shall be carefully checked for length, presence of water, dust, etc., with a wooden tamping pole or a measuring tape before loading
- 6.4. Surplus explosives shall not be stacked near working area during loading.
- 6.5. The line of detonating fuse extending into a bore hole shall be cut from cut from the spool before loading the remainder of the charge.
- 6.6 A bore hole shall not be loaded with explosives after springing (enlarging the hole with explosives) or upon completion of drilling without making sure that it is cool and that it does not contain my hot metal, burning or smoldering material. Temperature in excess of 65 C. are dangerous.
- 6.7 A bore o near another hole loaded with explosives shall not be sprung.
- 6.8 No force, shall be used for inserting cartridges or any explosive into a bore or pass any obstruction in a bore hole.
- 6.9 No force shall be used for inserting a blasting cap or an electric blasting cap into explosive. The cap shall be inserted into a hold made with a pricket designed for the purpose. A hitch of the electric blasting cap leading wire shall be made on the primer cartridge so as to prevent pulling out of the electric blasting cap from the explosive charge. In case of fuse, the fuse shall be tied to the explosive cartridge so that the blasting cap is not pulled out. Care shall be taken so that the electric blasting cap, leading wire or the length the fuse does not get damaged during loading of the charge.
- 6.10 No attempt shall be made to slit, drop, deform or abuse the primer
- 6.11 Blasting caps or electric blasting caps shall not be connected to detonating fuse except non-sparking metal connectors for jointed poles shall be used. Violent tamping shall be avoided. Primer shall not be tamped.
- 6.12 Care shall be taken to confine the explosives in the bore hole with sand, earth clay or other suitable combustible steaming material.
- 6.13 Kinking or injuring or fuse or electric blasting cap wires shall be avoided when tamping

7. Electrical short firing Circuit

- 7.1. In deciding the sizes of wires , fuses, circuits, blasting , switches , etc. instructions issued by the manufacturers of these articles should be consulted.
- 7.2.No personal shall tempt to uncoil the wires and open out the short circuited bare leading wires of the electric blasting cab during approach of dust storm or near any source of large charge of static electricity or near a radio transmitter. The manufacturer of the cap or the Inspectorate of Explosives shall be consulted regarding the distance from the transmitter, beyond which electric short firing shall be conducted.

Place
Date

Signature of the Bidder
(NAME & ADDRESS WITH SEAL)



BHARAT HEAVY ELECTRICALS LIMITED

POWER PLANT PIPING UNIT

THIRUMAYAM- 622 507

CONTRACTS DEPARTMENT

Phone : 04333279551

E.mail : ilango@bheltry.co.in Website : www.bhel.com

Tender No:PPPU:WC:14:015

Tender Notice

Dt. 04.10.2014

- 7.3 Firing circuit shall be kept completely insulated from the ground or other conductors, such as bare wires, rails, pipes, or other paths or stray current.
- 7.4. There shall not be any electric live wires or cables of any kind near electric blasting caps or other explosives except at the time and for the purpose of firing the blast.
- 7.5. All electric blasting caps shall be tested singly and also when connected in a circuit in series using only an approved type of circuit continuity tester or ohm meter.
- 7.6. No attempt shall be made to use in the same circuit either electrical blasting caps made by more than one manufacturer or electric blasting caps of different design of function even if made by the same manufacturers unless such use is approved by the manufacturers.
- 7.7. No attempt shall be made to fire a circuit of electric blasting caps with less than the minimum current specified by the manufacturer of that electric blasting cap.
- 7.8. Care shall be taken to ensure that all wire ends to be connected are bright and clean.
- 7.9. The electric cap wires or leading wires shall be kept short circuited until ready to fire.
- 7.10. When energy for blasting is taken from power circuits, the voltage shall not exceed 220. the wiring and controlling arrangements shall conform to the following :
- (a) The blasting switch shall be strictly according to the specifications, externally operated double – pole double throw switch, which when locked in the open position will short circuit and ground the leading wires The switch shall be installed at the location where the firing is to be controlled
 - (b) A 'Safety' switch of the same type as the blasting switch shall be installed between the blasting switch and the firing circuit and lead lines, at a distance not to exceed 180cm., from the blasting switch.
 - (c) Both the safety switch and the blasting switch shall be locked in the open position immediately after firing the short and before any person is permitted to return to the blasting area. Key to the switches shall remain in the possession of the blaster at all times.
- 7.11. Rubber covered or other adequately insulated copper wires in good condition shall be used for firing lines and shall have solid cores of appropriate gauge. Sufficient firing line shall be provided to permit the blaster to be located at a safe distance from the blast. Single conductor lead lines shall be used.
- 7.12. Blasting operations in the proximity of overhead power lines, communication lines, utility lines, or other structures shall not be carried on until the operator or the owner, or both of such lines has been notified and precautionary measures deemed necessary have been taken.
- 7.13. All holes loaded on a shift shall be fired on the same shift.
- 7.14. As far as possible blasting shall be carried out using suitable exploder with 25 per cent excess capacity. Electric power from the mains shall be used only when it is absolutely necessary.

8. Short firing with safety fuse :

- 8.1. The fuse shall be carefully handled to avoid damaging the covering. In very cold weather the fuse shall be slightly warmed before using so as to avoid cracking the waterproofing.
- 8.2. Short fuse shall not be used. The length of a fuse shall be not less than 120 cm. The rate of burning of the fuse shall be known and it would be necessary to make sure that it will take

Place
Date

Signature of the Bidder
(NAME & ADDRESS WITH SEAL)



BHARAT HEAVY ELECTRICALS LIMITED

POWER PLANT PIPING UNIT

THIRUMAYAM- 622 507

CONTRACTS DEPARTMENT

Phone : 04333279551

E.mail : ilango@bheltry.co.in Website : www.bhel.com

Tender No:PPPU:WC:14:015

Tender Notice

Dt. 04.10.2014

sufficient time in burning so as to enable all persons to reach a place of safety. The burning rate of the fuse shall not be more than 60 cm / min.

- 8.3. The fuse shall not be cut until the operation to insert the fuse into a blasting cap is ready. The fuse shall be cut off about 2.5 to 5 cm to ensure a dry end. It shall be cut squarely across with a clean sharp blade. The fuse shall be seated lightly against the cap charge and care shall be taken to avoid twisting after it has been placed in position.
- 8.4. Blasting caps shall not be crimped by any means except by a cap crimper designed for the purpose. It shall be necessary to make sure that the cap is squarely crimped to the face.
- 8.5. The fuse shall be lighted with a fuse lighter designed for purpose. If a match is used, the fuse shall be slit at the end and the match head held in the slit against the powder core and then the match head rubbed against an abrasive surface to light the fuse.
- 8.6. The fuse shall not be lighted until sufficient stemming has been placed over the explosives to prevent sparks of live match heads from coming into contact with the explosives.
- 8.7. The explosives shall not be held in hands when lighting the fuse.

9. Underground work :

- 9.1. Only permissible explosives and in the manner as specified by the appropriate authority shall be used
- 9.2. Excessive quantities of explosives shall not be taken underground at any time. Black blasting powder or pellet powder shall not be used with any other explosives in the same bore hole.
- 9.3. For blasting in tunnels and shafts precautions details in relevant Indian standard shall be followed. The poisonous gases shall be promptly removed by using exhaust fans in shafts and reversible axial flow fans in tunnels. The air duct shall be of such size as not to allow too much pressure drop so that the velocity of air at the delivery end is not less than 0.2 m/s.

9. Before and after firing

10.1. Before firing, sufficient warning shall be given to enable the people working in the blasting area to get off the danger zone. The danger zone shall be suitably cordoned off and flag men posted at important points.

10.2 No loose materials, such as tools, drilling implements, etc., shall be left on the rock surfaces to be blasted.

10.3 Blasting in the open shall be carried out during the fixed hours every day or on fixed days in the week. This information shall be amply publicized and the following precautions observed: -

- (a) On the projects sites, where regular blasting operations are carried out, daily blasting hours should be clearly printed on Sign-boards on all the roads approaching that area.
- (b) Road closing barriers should be provided to close the traffic on these roads, at least 400 metre away when the firing is to take place.

Place
Date

Signature of the Bidder
(NAME & ADDRESS WITH SEAL)



BHARAT HEAVY ELECTRICALS LIMITED

POWER PLANT PIPING UNIT

THIRUMAYAM- 622 507

CONTRACTS DEPARTMENT

Phone : 04333279551

E.mail : ilango@bheltry.co.in Website : www.bhel.com

Tender No:PPPU:WC:14:015

Tender Notice

Dt. 04.10.2014

(c) The beginning of the firing should follow loud sirens and similarly the completion of the firing should be succeeded by loud sirens.

10.4. The bore holes shall be thoroughly cleaned before a cartridge is inserted. Wooden tamping rods (not pointed, but cylindrical throughout) shall be used in charging the holes. The cartridges should be gently placed and not rammed. The primer cartridge will on the top .

10.5. The shot firer shall not return to the blasting site after firing, until at least 5 min, have elapsed. In case of electric shot firing, the shot holes shall be examined after firing and in case of misfire no person shall be allowed to approach the blasting for atleast 5 min. In case of shot firing with safety fuse utmost care shall be taken to count the number of loud reports to ensure that all the shots have fired and in the event of misfire, no person shall be allowed to approach the blasting site for atleast 30 minutes. In any case, careful inspection for remaining of un detonated explosives shall be made after firing the shots. All misfired shot holes shall be cross marked. No other person than those duly authorized shall be made after firing the shots. All misfired shot holes shall be cross marked. No other person than these duly authorized shall approach the holes until one of the following operations has been performed in respect of each of the misfired holes ;

- (a) If the misfire is due to a faulty cable or faulty electrical connection the defect shall be remedied and shot fired.
- (b) The stemming shall be floated out of use of water or air jet from those until the hole has been opened to within 60 cm. Of the charge, whereupon water will be siphoned or pumped out, then a fresh new charge placed and duly detonated.
- (c) A new hole shall be drilled 60 cm. Away from the old bore and parallel to it and about 30 cm. Less in depth and the new hole charged and duly fired.

10.6 A careful search shall be made of an exploded material in the debris of the second charge

NOTE : If a shift change is unavoidable, the person in charge of one shift before leaving the work shall inform the person relieving him for the next shift of any cases misfired and shall point out their positions duly cross marked and also state clearly what action has to be taken in the matter.

11. Explosives disposal :

- 11.1. No explosive shall be abandoned. They shall be disposed off destroyed strictly in accordance with the approved methods and in doing so the manufacturers or the appropriate authority shall be consulted.
- 11.2. Explosives, caps, boxes lines or material used in packing of explosives shall not be left lying around in places to which children or un authorised persons or livestock can have access.
- 11.3. No paper or fiber material employed in packing explosives shall be put to any subsequent use. Such material shall be destroyed by burning in the presence of a responsible person.

APPENDIX XXV.

Place
Date

Signature of the Bidder
(NAME & ADDRESS WITH SEAL)



BHARAT HEAVY ELECTRICALS LIMITED

POWER PLANT PIPING UNIT

THIRUMAYAM- 622 507

CONTRACTS DEPARTMENT

Phone : 04333279551

E.mail : ilango@bheltry.co.in Website : www.bhel.com

Tender No:PPPU:WC:14:015

Tender Notice

Dt. 04.10.2014

FORM OF AGREEMENT FOR THE REMOVAL OF BUSHES, TREES, PRICKLY PEAR, ETC., ON THE DUTCH AUCTION SYSTEM

(Vide relevant remarks in paragraph 210 of the Tamil Nadu Public Works, highways and Rural Works Department Code) .

DUTCH AUCTION SYSTEM

FORM OF AGREEMENT

Articles of Agreement made this _____ day of _____ between His Excellency the Governor of Tamil Nadu (hereinafter called the Governor which expression shall where the context so admits include his successors in Office and assigns) of the one part and _____ of _____ (herein after called "the contractor" which expression shall where the context so admits include his heirs / executors, administrators and legal representatives) of the other part.

Whereas it has been agreed by and between the parties here to that the contractor shall effect the clearance of prickly pear bushes trees, etc., over the area in accordance with the measurements set forth in Schedule a hereto in the manner set forth in the Standard specification in National Building Code and Tamil Nadu Building Practice such work to be carried out and completed in accordance with the condition set forth in Schedule B hereto and to be paid for as therein provided the terms and provisions contained in the said schedule hereto being read with and forming part of this contract and whereas the contractor has deposited with, the sum of Rs._____ Equivalent to 5 percent of the amount specified in the clauses below as security for the due fulfillment of the contract to the satisfaction of the Executing EngineerDivision.

Now it is hereby agreed that in consideration of the payment of the sum of Rs._____

The contractor, will, upon and subject to the condition set forth in Schedule B hereto, execute and complete the works entered in Schedule A.

SHECUDLE B

SCHEDULE OF CONDITIONS OF CONTRACT

1. Works referred to : - The measurement entered in detail in Schedule A show the area over which the clearance of prickly pear bushes, trees, etc., has to be done they shall be carefully followed :
2. Works and specification : - The work shall be carried out to the satisfaction of the Executive Engineer, Division (hereinafter called the Executive Engineer) in accordance with his

Place
Date

Signature of the Bidder
(NAME & ADDRESS WITH SEAL)



BHARAT HEAVY ELECTRICALS LIMITED

POWER PLANT PIPING UNIT

THIRUMAYAM- 622 507

CONTRACTS DEPARTMENT

Phone : 04333279551

E.mail : ilango@bheltry.co.in Website : www.bhel.com

Tender No:PPPU:WC:14:015

Tender Notice

Dt. 04.10.2014

directions and in compliance with the said measurements, specification and written instruction in explanation of the same as may from time to time be given by the Executing Engineer or his authorized representative at the spot.

3. Power of Executing Engineer to order removal of improper work : In case of default on the part of the contractor to carryout the work in accordance with the specifications, the Executing Engineer shall have power to employ and pay other persons to carry out the same at the contractor's risk and all expenses consequent thereon or incidental thereto shall be borne by the contractor and shall be recoverable from him by the Government of Tami Nadu (hereinafter called the Government) or may be deducted by the Government from the security deposits mentioned in clause 8 below or from any moneys due or that may become due to the contractor.
4. Defects after completion : - Any defects or other faults which may appear within one month after completion of the work shall upon the directions in writing of the Executive Engineer, be amended and made good by the contractor at own cost, failing which Executing Engineer shall pay him such reduced amount as he think fit or deal with him as provided for under clause 8. The final payment for the work shall therefore be deferred for such period as herein mentioned after the date of completion.
5. Date of commencement and completion : - The contractor shall forthwith commence work and complete the same within a period of calendar month after the date of commencement subject nevertheless to the provision or extension of time hereinafter be considered as of essence of this agreement.
6. Extension of time : - If in the opinion of the Executing Engineer the works shall have been delayed on account of any reasonable cause, the Executing Engineer may grant in writing a fair extension of time for completion.
7. Payment and Certificates : - the Executing Engineer will cause only one final payment to be made to the contractor if the total amount of the contract is Rs. 300 and less. But if the contract amount exceeds Rs. 300 he may cause intermediate payments to be made upon certificates to be issued at reasonable frequent intervals, either by himself or by an Officer of rank not less than that of an Assistant Executing Engineer to the extent of 75 per cent will be dealt with as

provided below. The contractor when applying for a certificate shall furnish to the Executive Engineer a statement of measurements of the works executed based on the original detailed estimate of quantities include in Schedule A together with a bill.

In calculating the amount of each item due to the contractor in every bill submitted for payment under the contract, sums of less than 2 ½ percent shall be omitted and sum of 2 ½ percent and more but not exceeding 5 per cent shall be reckoned as 5 per cent. The amount shall be rounded to the nearest rupees, sums of less than 50 paise being omitted and sums of 50 paise and more being reckoned One rupee.

Place
Date

Signature of the Bidder
(NAME & ADDRESS WITH SEAL)



BHARAT HEAVY ELECTRICALS LIMITED

POWER PLANT PIPING UNIT

THIRUMAYAM- 622 507

CONTRACTS DEPARTMENT

Phone : 04333279551

E.mail : ilango@bheltry.co.in Website : www.bhel.com

Tender No:PPPU:WC:14:015

Tender Notice

Dt. 04.10.2014

8. Security deposits : - In cases where the contract amount exceeds Rs. 300 the 25 per cent of the value of the executed work withhold from intermediate bills under clause 7 above, will be treated as further security in addition to the security deposit mentioned in the agreement. These security deposits or so much thereof as may be returnable will be refunded after the expiration of the period fixed in clause 4 above. If the contractor fails to start work forthwith or to executive the work within the period fixed in clause 5 or within such extended time as may be allowed under Clause 6 or if the contractors shall be guilty of a breach or non – observance of any of the conditions herein contained and to be performed or observed by him it shall be lawful for the Executive Engineer, in addition and without prejudice to the other rights and remedies of the Government, to determine the contract and such determination shall carry with it the forfeiture of the security deposits mentioned above together with the value of a such work as may have been executed and not paid for or such portion of such sums as may be decided by the Executive Engineer.

SPECIFICATION NO.22

TURFING

1. I.S. 4701 / 1968, particularly paragraph 10 dealing with the above subject shall also apply.
2. Taking over : - The turfing or planting shall be finished by the beginning of the rainy season. But should not be taken over from the contractor until it has formed a complete close grassy growth over the earth. No area which does not show a good health growth shall be paid for.

SPECIFICATION NO. 23.

EXCAVATING FOUNDATIONS

1. Excavated material is not to be placed nearer than 1M from the outer edges of the excavation but shall be placed anywhere within 50 metre, as may be ordered by the Executing Engineer without extra payment. For removal beyond 50 metre, vide clause 6 below :
2. The bottom of foundation pits shall be dressed level in all directions and before any concrete is put in, shall be well watered and thoroughly rammed. The foundation trenches shall be dug out to the exact width of the lowest step of the footing and the depth shall be in accordance with the plans, or as may be otherwise ordered by the Executive Engineer. In firm soils, the side of a trench shall be kept vertical upto a depth of 2 metres from the bottom and for a greater depth, the trench shall widened by allowing steps of 50 cm on either side after every 2 metres depth from the bottom, so as to give a vertical side slope of $\frac{3}{4}$ to 1. The earth work excavation made shall be measured and paid for, taking into account sloping back as laid down above. The excavation made in excess of the above requirements shall not be measured and paid for

Place
Date

Signature of the Bidder
(NAME & ADDRESS WITH SEAL)



BHARAT HEAVY ELECTRICALS LIMITED

POWER PLANT PIPING UNIT

THIRUMAYAM- 622 507

CONTRACTS DEPARTMENT

Phone : 04333279551

E.mail : ilango@bheltry.co.in Website : www.bhel.com

Tender No:PPPU:WC:14:015

Tender Notice

Dt. 04.10.2014

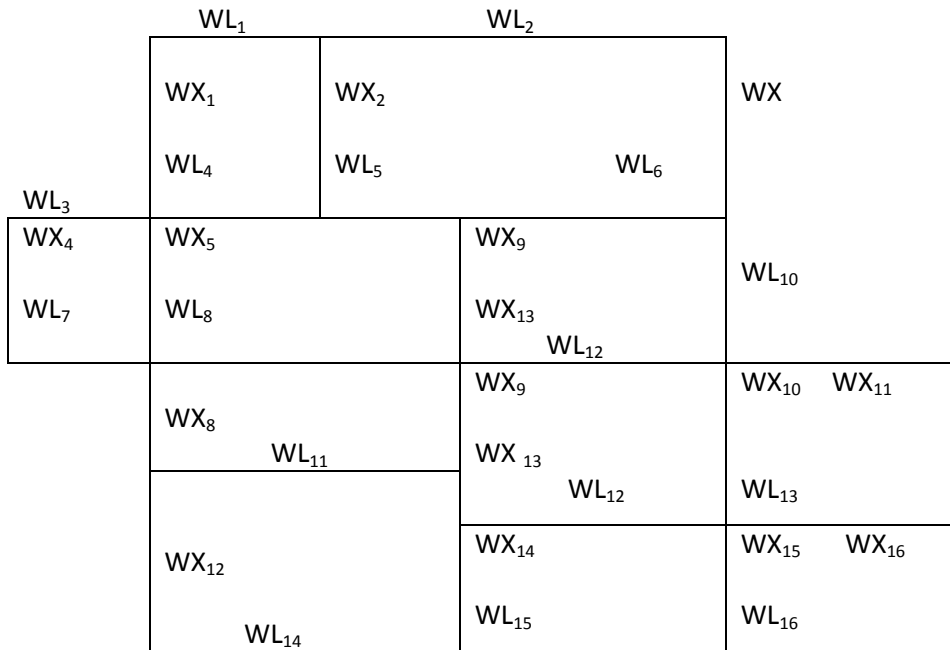

TYPICAL MARKING DETAILS FOR WALLS

- 2.1. For excavation in loose solid I.S. 3764 shall be followed
- 2.2. Where different foundation levels are necessary I.S. 1904 may be followed.
- 2.3. If, by the contractor's mistake the excavation is made deeper or wider than shown on the plans, the extra width or depth shall be made up with concrete – and not with earth or other material – at the cost of contractor.
3. Should rocks, or remains of old buildings, be met with, the material shall be removed with wedges and levers. Blasting will not be allowed, without the permission in writing of the Executive Engineer. In cases where the Executive Engineer considers blasting is essential, the extra rate, if any to be paid shall be fixed in writing before the work is put in hand.
4. If bad ground or loose soil be met with, the contractor, will be responsible for reporting the fact to the Executing Engineer who will issue such order as may be necessary. For extra excavation, concrete and masonry arising from bad ground, the contractors shall be paid extra according to the schedule of rates agreed to.
5. Before concrete is laid in the trenches, they shall be passed by the Executive Engineer.
6. All excavated earth, which is unfit or surplus to requirements for filling in, shall be spread as instructed in the standard specification for "Filling in foundation" at the contractor's expense. If the excavated earth is to be removed beyond 50 metres, then the rate in the agreement for extra lead will be paid or in the absence of such rate, the contractor will be paid in accordance with the schedule of rates of the Division in which the work is being executed. If the cartage is cheaper than head loads, then cartage shall be done and all rate shall be fixed in writing by the Executing Engineer before cartage is begun.
7. The contract rate for excavation of foundation shall include the following :

Place
Date

Signature of the Bidder
(NAME & ADDRESS WITH SEAL)



BHARAT HEAVY ELECTRICALS LIMITED

POWER PLANT PIPING UNIT

THIRUMAYAM- 622 507

CONTRACTS DEPARTMENT

Phone : 04333279551

E.mail : ilango@bheltry.co.in Website : www.bhel.com

Tender No:PPPU:WC:14:015

Tender Notice

Dt. 04.10.2014

- a) Setting out works, profiles, etc.
- b) Site clearance, preparation of bed
- c) Forming deadman or thandoos and their removal after
- d) Forming (or leaving) steps inside of deep excavation and their removal after measurements.
- e) Excavation for insertion of planking and strutting
- f) Unless otherwise specified, removing slips or falls in excavation.
- g) Bailing out water on excavation from rains, sub-soil water, etc.
- h) Shifting or supporting pipes, electric cables, etc., met during excavation.

NOTE : pumping out water caused by springs, tidal or river seepage broken water mains or drains, well point pumping and the like shall be measured in kilolitres of water and paid for separately.

8. Shoring, sheeting, planking, strutting, etc., needed for supporting sides of excavation shall be paid for separately unless otherwise specified in the description of relevant schedule items and in addendum Extra rate for work in or under water, in or under foul conditions , under tides and in snow shall be paid for unless otherwise specified in the description of relevant schedule items and in addendum specifications. The levels of high and low water tides where occurring shall stated in the tender schedule :
9. Classifications of soils for earth work I.S. 1200 Part I shall apply.

NOTES : 1. In all such cases, the classification as made by the Executing Engineer shall apply and the contractor shall make the excavation under the most favourable conditions, when so instructed by the Executive Engineer. No revision of classification will be made by the Executive Engineer.

- 1.1. When rock is to be excavated by blasting, it will always be specified before work starts. In no case is blasting to be done before a rate has been agreed on and the approval of the Executing Engineer to such action obtained.
- 1.2. Contract rate for any classification of soil assumes that wedges, levers, picks, mamooties and manual tools only are to be used in excavation and in no case will the contractor be allowed to obtain a revision of classification on the ground that blasting is necessary unless such necessity is approved by the Executing Engineer prior to commencement of blasting. In lump sum contracts, the contractor assumes the risk of meeting with hard rock, requiring removal without extra compensation unless separate provision for such contingency is specifically entered in the conditions of contract.

At places of foundation where existence of colonies of subterranean termites are found or where the structure is likely to be attacked frequently chemical barriers which prevent the termite from reaching the superstructure of the building shall be introduced. The soil

Place
Date

Signature of the Bidder
(NAME & ADDRESS WITH SEAL)



BHARAT HEAVY ELECTRICALS LIMITED

POWER PLANT PIPING UNIT

THIRUMAYAM- 622 507

CONTRACTS DEPARTMENT

Phone : 04333279551

E.mail : ilango@bheltry.co.in Website : www.bhel.com

Tender No:PPPU:WC:14:015

Tender Notice

Dt. 04.10.2014

treatment for anti-termite measures in buildings i.e. in basement excavation, column pits and wall trenches shall be as per I.S. 6313 (Part II) .

SPECIFICATION NO. 24

FILLING IN FOUNDATIONS

1. All foundation shall be refilled to the original surface of the ground with approved materials, well watered and rammed.
2. The contractor shall not fill in around any work, until it has been approved by the Executive Engineer. In cases where the excavated foundation soil is to be used for refilling, it shall be brought back from the place, where it was temporarily deposited, and the trenches or other excavations shall be filled up to the height of the original surface with this earth, carefully rammed in regular layers of not more than 20cm in thickness, and consolidated by the addition of water to each layer as and if found necessary according to the directions of the Executive Engineer.
3. After completion of the building, the ground shall be carefully dressed with a gentle outer slope for a distance of 50 metres, all round the building, unless otherwise described in the schedule item description or otherwise directed by the Executive Engineer. The contract unit rate for "Filling in Foundations" is inclusive of this work.
4. The dimensions of consolidated earth shall be measured for the purpose of payment, where returning filling and ramming of excavated earth is not described with the item of excavation. The dimensions of filling shall be measured correct to the nearest cm. And cubical contents worked out correct to two places of decimal.

SPECIFICATION NO. 25

FILLING IN BASEMENT

1. Materials for filling in basement shall be as defined in the general specification or descriptive specification sheet ; or shall be brought from a source approved by the Executive Engineer.
2. The surface to receive the filling shall be first cleared free from all roots, vegetation or spoil and wetted.
3. Filling upto plinth level is to proceed in layers with the construction of the building so that the earth, filling may be thoroughly consolidated by the tamping of the workers. It shall have optimum moisture content and well rammed in layers of 15 cm. After thorough consolidation, a sufficient quantity of the filling is to be removed to make room for the flooring. For floors to rooms, the excavation shall be level and for verandah, the slope shall be 20 mm. per metre towards the verandah edge, unless other slope is specified, shown on the drawings or ordered by the Executive Engineer. The depth excavated should correspond with the required thickness of the floor.

Place
Date

Signature of the Bidder
(NAME & ADDRESS WITH SEAL)



BHARAT HEAVY ELECTRICALS LIMITED

POWER PLANT PIPING UNIT

THIRUMAYAM- 622 507

CONTRACTS DEPARTMENT

Phone : 04333279551

E.mail : ilango@bheltry.co.in Website : www.bhel.com

Tender No:PPPU:WC:14:015

Tender Notice

Dt. 04.10.2014

4. Where sand filling is specified, the sand shall be clean, free from a mixture of foreign material and approved by the Executing Engineer before filling is commenced. Should there be a necessity to fill in a basement with sea sand prior written approval of the Executive
5. Engineer shall be obtained. Sand filling should be saturated with water and the flooring should be laid in this condition.
6. Filling in basement shall have optimum moisture content and, well consolidated in layers of 15 cm. By ramming with iron rammers and butt ends of crowbars. When filling reaches finished level the surface shall be flooded with water for at least 24 hours, allowed to dry and then rammed and consolidated in order to avoid any settlement at a later stage.

SPECIFICATION No. 26 A

WELL-SINKING FOR FOUNDATIONS

1. Excavation : - Unless otherwise specified, open excavation shall be carried down to 30 cm. Above sub soil water level, before the well curb is laid.
 - 1.1. I.S. 3955 shall apply for formation of island to sink well foundation in water (particularly refer para 6.4). The island shall be brought up atleast 30 cm. Above the water level before the well curb is laid and if the Executing Engineer shall so direct, the sides of the island shall be protected from erosion by means of suitable piles and shuttering. Separate agreement rates for this work being decided on before the work is done, unless the work is to be done under an all inclusive lump sum agreement
 - 1.2. Whether steining be sunk, or constructed in open excavation by bailing as necessary blasting must never be resorted to without obtaining prior permission of the Executing Engineer I.S. 3955/- 1967 shall also apply.
 - 1.3. The instructions contained in the clauses 1 to 1.2 under 'Notes' to Standard specification for "Excavating Foundations" shall apply also to this specification : -

Paragraphs (2) and (4) regarding precautions in bad ground.

Paragraph (3) regarding rocks or remains

Paragraph (6) regarding removal of unfit or surplus material.

Paragraph (2), (7) and (8) regarding shorting dewatering, etc.

2. Curbs : The design for the curb will be made by the Executing Engineer and in cases where the curbs are to be supplied by the contractor, they shall be in conformity to the sanctioned plans there. The curb will be made 25 mm. greater in diameter than the steining ; The curbs shall be assembled and passed by the Executing Engineer before the steining is commenced. If it is necessary to take curb, apart, for the purpose of lowering to the bottom of excavation, the parts shall be numbered and re-assembled at the bottom of excavation. Wooden curbs for wells of 2 metre diameter and under will be made of two thickness of wood, and for wells above that size of three thickness or more unless other design is shown on the plans or ordered by the Executive Engineer. When the rings cannot be made of one piece across the width, the concentric rings shall break joint ; successive layers of the curb shall also break joint ; successive

Place
Date

Signature of the Bidder
(NAME & ADDRESS WITH SEAL)



BHARAT HEAVY ELECTRICALS LIMITED

POWER PLANT PIPING UNIT

THIRUMAYAM- 622 507

CONTRACTS DEPARTMENT

Phone : 04333279551

E.mail : ilango@bheltry.co.in Website : www.bhel.com

Tender No:PPPU:WC:14:015

Tender Notice

Dt. 04.10.2014

layers of the curb shall also break joint with the rings above and below them. The separate pieces in each layer shall be cut to the requisite curve and each shall not be less than 1.2 m. long 20 cm. Wide and 14 cm. Thick unless otherwise shown on the plan or otherwise specified. All individual segments of each ring shall be strongly dovetailed together and the successive rings, dowelled together with hardwood dowels – all to the satisfaction of the Executive Engineer. Iron bolts will also be used for jointing the several layers of the curb, as may be shown on the plans or ordered by the Executive Engineer. Iron bolts will also be used for jointing the several layers of the curb, as may be shown on the plans or ordered by the Executive Engineer. The curb shall be leveled up truly, and brought to exact position before the steining is commenced.

N.B. – Wooden curbs – (see Memorandum No. 5807 – Works 92 C.P. dated 15th November 1929, for suitable wood – babul, tamarind, mango or teak being also suitable) are commonly used for moderate size wells, but reinforced concrete curbs will be frequently found cheaper. Curbs with steel cutting edge are used for large size wells

3. Tie – rods – Holes shall be drilled in the middle of the curbs to receive the tie – rods. Tie – rods shall be threaded both ends and fixed through and to the bottom of the well curb by nuts and washes and shall be carried up – forming a continuous length to the height specified or shown on the drawings. Unless otherwise specified or ordered, they shall be 20 mm diameter and in 3 m lengths, not more than 1.5 m. apart circumferentially measured and shall be joined together at bond rings or plates by 15 cm. Long bottle nuts. The plans will show or it will be specified, if the upper end of the tie – rods shall be threaded through iron plates or weather through a 80 mm, x 10 mm. flat iron bond ring (temporarily secured to keep the rods vertical and immovable while the steining is being built around them.) the upper nuts will be screwed down to press against the top of the steining, and strengthen the steining while it is being sunk and they must be kept truly vertical and in the center of the steining throughout their height.

4. Steining.-I.S. 3955 shall apply (particularly refer para 4.3.1.(c) and 5.10.3.)

4.1. It is desirable to have specially moulded bricks for well steining but such bricks, if demanded, will be so specified.

4.2. If plastering is to be done to the outside of the well to facilitate sinking, it will be so specified under the description of the masonry.

5. Sinking.-para 5.9.1. of I.S. 3955 also shall apply.

5.1 Sinking must not be started till the depth of the masonry to be sunk has set and until the steining has been passed by the Executing Engineer and commencement of sinking approved.

5.2 The contractor shall arrange his own method of sinking unless otherwise specified or ordered by the Executing Engineer (i.e.), either by manual labour or drivers, weighting the top of the steining to assist sinking.

Place
Date

Signature of the Bidder
(NAME & ADDRESS WITH SEAL)



BHARAT HEAVY ELECTRICALS LIMITED

POWER PLANT PIPING UNIT

THIRUMAYAM- 622 507

CONTRACTS DEPARTMENT

Phone : 04333279551

E.mail : ilango@bheltry.co.in Website : www.bhel.com

Tender No:PPPU:WC:14:015

Tender Notice

Dt. 04.10.2014

5.3 No dewatering of the wells must be done during sinking without obtaining prior permission of the Executing Engineer and any damage which may result either to the well or adjoining structures by such dewatering shall be made good at the contractor's expense.]

5.4 For well sinking I.S. 3955 shall apply (Particularly refer paras 6.7 and 7.2).

If it is necessary to sink a well deeper than the specified depth, in order to correct may tilt or error of position, such sinking must be done at the contractor's expense. If the Executive Engineer so instructs, the sinking shall be done continuously working day and night till the required depth is reached. Wells shall not be left, partially sunk during period of probable floods. Rectification of damage to partially sunk wells from any cause shall be made good by the contractor to the satisfaction of the Executive Engineer.

6 Removal of bad work – If the steining splits during the sinking or within six months after completion, and in the opinion of the Executive Engineer, be unsound the contractor shall be bound to dismantle the whole or part according to circumstances and reconstruct it without charge, and if the failing in of the sides of the excavation from insufficient shoring, or any other cause due to the negligence of the contractor, renders it necessary in the opinion of the Executive Engineer, the contractor shall be bound to construct and sink an entirely new well without charge.

7 Protection during construction – Attention is directed to the relevant clauses of the standard general conditions of contract.

8 Rate : - In the case of lump sum contracts, the work will be executed for a definite contract amount but completed according to the plans and specifications.

8.1 Tools and plant shall be supplied by the Contractor at his own expense. Both for dredging and dewatering where such is required – Unless other arrangements are definitely prescribed in the relevant specifications or tender notice. The contractor shall quote his tender rate accordingly. The contractor's attention is directed in this connection to the relevant clauses in the standard general conditions of contract, but it is to be understood that Executive Engineer does not bind himself to supply any tools and plant on hire.

8.2 If the schedule prescribes payment for separate items of the well – then

(i) Earth work for open excavation will be paid only for its quantity actually to be excavated taking into account sloping back as mentioned in the relevant specification for earth work in foundation. The excavation made in excess of the above requirements shall not be measured and paid for notwithstanding that the contractor may find it more convenient to take out the excavations at slopes other than those shown in the plan to avoid shoring. In every case the contractor shall make excavations perfectly safe at all stages, for the workmen, for whose safety he shall be wholly responsible

Place
Date

Signature of the Bidder
(NAME & ADDRESS WITH SEAL)



BHARAT HEAVY ELECTRICALS LIMITED

POWER PLANT PIPING UNIT

THIRUMAYAM- 622 507

CONTRACTS DEPARTMENT

Phone : 04333279551

E.mail : ilango@bheltry.co.in Website : www.bhel.com

Tender No:PPPU:WC:14:015

Tender Notice

Dt. 04.10.2014

- (ii) Curbs will be paid for per curb or per 0.01 cubic metre as indicated in the relevant schedule item.
- (iii) Masonry shall be paid for on the quantities as shown in the schedule or deduced from the plan
- (iv) Sinking shall be measured per meter run, for different depth as specified in the contract. The depth of sinking shall be measured to the bottom of well curb from the actual level at which the cutting edge was laid and in no case 30 cm. Above sub – soil water level. The rate for sinking will be inclusive of all dredging and dewatering as necessary and inclusive of all tools and plant.

SPECIFICATION NO. 26 – B

WELL SINKING FOR WATER SUPPLY

1. The work shall be executed to the standard specification for “well sinking for foundations”.
2. If dry stone masonry is to be laid, it shall be executed to the relevant standard specification, either coursed or random rubble as specified, without mortar, and with width of vertical open joints as specified, to the true shape of the well as per plan ; and if of dry brick masonry, width of open joints, bond and type of bricks to be used will be specified.
3. Platform, parapet, pulley arrangement, ladder or rungs in well steining drain etc., shall be executed as shown in the relevant plan, standard specification materials being used in all parts of the work

NOTE : (1) Thickness of steining - The following dimensions are suitable

Depth of well from ground level	Brickwork	Stone masonry
(1)	(2)	(3)
Wells 3 metres and under	.. .40 cm	30 cm
Wells – Above 3 metres and upto 10 metres	..50 cm	40 cm
For every additional 3 metre depthIncrease the thickness	by 10 cm

- (ii) Where wells are excavated in hard ground and no puddle or other lining is required, steining should be provided for a depth of atleast 2 metres to prevent pollution from surface washings.

EXTRACT FROM I.S. 4701

Code of practice for earthwork on canals.

4. Clearing :-

- 4.1. The land over which embankments are to be formed and other excavation is to be carried out shall be cleared of all trees, bushes, rubbish, ant hills and other objectionable matter.

Place
Date

Signature of the Bidder
(NAME & ADDRESS WITH SEAL)



BHARAT HEAVY ELECTRICALS LIMITED

POWER PLANT PIPING UNIT

THIRUMAYAM- 622 507

CONTRACTS DEPARTMENT

Phone : 04333279551

E.mail : ilango@bheltry.co.in Website : www.bhel.com

Tender No:PPPU:WC:14:015

Tender Notice

Dt. 04.10.2014

4.2 It is desirable to protect the trees outside the outer edge of the canal embankments. However, the presence of trees in the vicinity of a canal can accentuate variation of moisture content in the substratum. In the case of expansive soils such excessive moisture variation can result in damage to the lining. Such influence is believed to extend to distances equal to twice the height of the tree

Place
Date

Signature of the Bidder
(NAME & ADDRESS WITH SEAL)



BHARAT HEAVY ELECTRICALS LIMITED

POWER PLANT PIPING UNIT

THIRUMAYAM- 622 507

CONTRACTS DEPARTMENT

Phone : 04333279551

E.mail : ilango@bheltry.co.in Website : www.bhel.com

Tender No:PPPU:WC:14:015

Tender Notice

Dt. 04.10.2014

SECTION IV CONCRETE

INDIAN STANDARDS EXTRACTS

I.S. Number (1)	(2)
	Notes on R.C.C. design
2541	Code of practice for use of lime concrete in buildings
269	Specification for ordinary, rapid-hardening and low heat Portland cement
1791	Specification for batch type concrete mixers
3370	Code of practice for concrete structures for storage of liquids prestressed concrete structures
432	Specification for mild steel and medium tensile steel bars and hard drawn steel wire for concrete reinforcement –
1139	Part I – Mild steel and medium tensile steel bars Part II – Hard drawn steel wire
456	Code of practice for plain and reinforced concrete (II revision)
5525	Recommendations for details of reinforcement in reinforced concrete
2751	Code of practice for welding of mild steel bars used for reinforced concrete construction
1199	Methods of sampling and analysis of concrete
2502	Code of practice for bending and fixing of bars for concrete reinforcements
3370	Code of practice for concrete structures for the storage of liquids Part I – General requirements Part II – Reinforced concrete structures
1346	Code of practice for water proofing of roofs with bitumen felts
4365	Code of practice for application of bitumen mastic for water proofing of roofs
C.B.R.I.	Cored Unit for Roof / Floor – Data sheet No.3
	Channel unit for floor / roof – Data sheet No.5
	Pre cast R.C. Plank C.B.R.I. flooring roofing – Data sheet No.7
	Waffle unit for roof / floor – Data sheet No. 6

Place
Date

Signature of the Bidder
(NAME & ADDRESS WITH SEAL)



BHARAT HEAVY ELECTRICALS LIMITED

POWER PLANT PIPING UNIT

THIRUMAYAM- 622 507

CONTRACTS DEPARTMENT

Phone : 04333279551

E.mail : ilango@bheltry.co.in Website : www.bhel.com

Tender No:PPPU:WC:14:015

Tender Notice

Dt. 04.10.2014

2911(Part III)	Code of practice for design and construction of pile foundations under-reamed pile foundation.
----------------	--

SPECIFICATION NO.28

CEMENT CONCRETE

1. I.S. 456 I.S. 383 , and I.S 269 shall also apply.
2. Mixing Concrete : - Cement and sand shall be measured in accurate proportions, and well mixed in a dry state, thrice over, on a clean dry platform of wood or slabs with tight and even joints, so that there may be no wastage of mortar, or difficulty in mixing. As much quantity of the aggregate, washed and cleaned of dirt and allowed to dry, as can be mixed and laid within 15 to 20 minutes after water is added to the mixture, shall then be laid on the dry platform and on it shall be spread the dry mixture of cement and sand in correct proportions. The cement is to be weighed 50 kg. Being taken as 35 litre and measuring boxes are to be used to maintain the correct proportions of sand and broken stone. A convenient size of measuring box would be inside dimensions of 40 cm long, 35 cm wide and 25 cm deep. The mixing platform should be large enough to enable the continuous procedure of two batches being mixed, to avoid partial sets of the concrete between saying of successive batches. The whole mass shall then be thoroughly mixed with a shovel, turning over atleast three times, and adding sufficient quantity of water with a sprinkling until the colour of the cement is uniformly distributed throughout the whole mass.
The whole operation shall be so arranged as to take the minimum time possible, so that the mixed concrete shall be placed in position before initial setting begins. Concrete which had begun to set or which has been condemned by the Executing Engineer shall be rejected and removed from the work spot.
3. For water for mixing are to include the cost of mixing, conveying, placing, ramming, watering, barrows tools and all appliances required complete the concrete in position. They shall also include the cost of bailing and pumping for keeping the excavation free of water, unless otherwise specified. Centering shall be measured and paid separately.

Quantities : The standard data for the division is to be followed for the quantities of material and labour required for the various items of work. The relevant schedule item will define the proportion of cement to sand i.e. whether 1 : 2 or 1 : 3 etc.

SPECIFICATION NO. 29

REPAIR GROUTING TO APRONS AND REVETMENTS WITH SURKI CONCRETE AND POINTING WITH SURKI MORTAR.

Place
Date

Signature of the Bidder
(NAME & ADDRESS WITH SEAL)



BHARAT HEAVY ELECTRICALS LIMITED

POWER PLANT PIPING UNIT

THIRUMAYAM- 622 507

CONTRACTS DEPARTMENT

Phone : 04333279551

E.mail : ilango@bheltry.co.in Website : www.bhel.com

Tender No:PPPU:WC:14:015

Tender Notice

Dt. 04.10.2014

- 1) The surface of the apron or revetment shall be thoroughly cleaned and the joints raked out to 230 mm depth. The whole surface shall be swept clear
- 2) The joints shall then be filled in with surki mortar concrete prepared in accordance with the standard specification for same 1. lime, ½ surki, 1-1 / 12 sand and with stone or brick jelly as specified broken to 6 mm to 20 mm cubes. If the interstices are arge, a larger size aggregate will be specified by the Executive Engineer. The concrete shall be rammed with flat bars, trowels or flat ends of small think crow-bards to ensure close compaction.
- 3) The surface shall then be pointed flush with standard specification surki mortar, covering the joints of the newly laid concrete filling by 5 mm. The pointing must be done before the concrete before set, in order that it may bond well with it. The joints be finished off neatly.
- 4) Special attention is necessary to keep the concrete and pointing continuously wet at all stages of the work and for three weeks after completion (by covering with sand or mats and keeping same watered as otherwise the effect of the sun on the exposed face of an apron or revetment will cause the concrete and pointing to perish before they have set.

NOTE : If 2,30 mm raking of joints is unsuitable for any particular work, the alteration to the standard specification should be stated in the tender notice.

SPECIFICATION NO. 30 REINFORCED CONCRETE WORK

- 1) For aggregate, sand and cement specifications given in section I materials of this shall apply.
- 2) Steel reinforcement : - Specification of reinforcement is covered by I.S. 456 : 432 : , 1139 : 1786 : and 2562 :
 - (a) In the case of rods supplied by contractor test certificate may be called for, or the rods tested in a Laboratory as may be approved by the Executive Engineer.
 - (b) All protruding bars from piers, columns, beams and slabs to which other bars are to be spliced, and which may be left exposed to the action of the weather for an indefinite period shall be protected from rusting by encasing the same in lean cement. Brick jelly concrete mix 1:5:10 (one cement, five sand and ten brick jelly) and the surface plastered over with cement mortar 1 : 5.
 - (c) After all the steel has been placed in position, it should be passed by the Executing Engineer or by his representative, before any concrete is laid/
 - (d) No part of the reinforcing metal in a building shall have such contact as to enable the same to transmit any electrical current

Place
Date

Signature of the Bidder
(NAME & ADDRESS WITH SEAL)



BHARAT HEAVY ELECTRICALS LIMITED

POWER PLANT PIPING UNIT

THIRUMAYAM- 622 507

CONTRACTS DEPARTMENT

Phone : 04333279551

E.mail : ilango@bheltry.co.in Website : www.bhel.com

Tender No:PPPU:WC:14:015

Tender Notice

Dt. 04.10.2014

4. Splices or overlaps of reinforcement : I.S. 456 : , I.S. 5525 : , 2502 : shall apply, 456 : and 2751 : shall apply for welding.

The following shall be observed to safeguard against failure of structural members :

- 4.1. (i) For all R.C.C. works, the Executive Engineer shall prepare detailed section with dimensions and bar-bending schedules and furnish the same to the contractor after affixing his approval. The fact of furnishing such approved bar – bending schedule and working sketches should be recorded in the concerned file.

(ii) When all the reinforcement have been placed in position, the Executing Engineer or his representatives, not below the rank of Assistant Executing Engineer should inspect and pass the same before any concrete is laid

(iii) The Executing Engineer shall personally satisfy himself about the adequacy and soundness of the scaffolding and entering before concreting is started.

5. Mixing concrete : - (1) (a) All arrangements shall be made, before mixing is started, to ensure that there will be no stoppage of work at a stage of mixing, handling, placing and tamping, as such stoppage may lead to exceeding of the permissible time – limit laid down for finally placing the concrete in the forms upto a pre-determined stopping point. Concrete which is not placed in position within the permissible time – limit shall be rejected.

- (b) In all cases, the mixing and laying of concrete shall be done only the presence of the officer in immediate charge of the work ; the contractor or his agent shall give due notice to the Executing Engineer or his representative when mixing is to be proceeded with. The Executing Engineer or his deputy may reject any concrete mixed, when such notice is not given

(ii) Hand Mixing : - (a) If the concrete is mixed by hand, the mixing platform shall be large enough to provide space for the partially simultaneous mixing of batches of about 0.25 m³ each or any other quantity fixed by the Executive Engineer. Paragraph 20 1-2-2 of I.S. 456 : shall also apply.

- (c) Cement shall be superimposed over the sand, and the sand and cement thoroughly and evenly mixed, until a uniform colour is attained. It shall be turned atleast three times. The sand and cement mixture and the aggregate shall then be placed in superimposed layers, the former on top and mixed dry thoroughly atleast three times. Sufficient water should then be added, using a hose, to produce the required consistency and then turned together, at least three times, exclusive of the shoveling or handling from platform to place of deposit or into the vehicle of transport. The number turnings shall be sufficient to produce a concrete thoroughly mixed and of a consistency, uniform throughout, the use of a rake or hoe can be permitted for mixing sand and cement, but not when stone comes into the mix.

Place
Date

Signature of the Bidder
(NAME & ADDRESS WITH SEAL)



BHARAT HEAVY ELECTRICALS LIMITED

POWER PLANT PIPING UNIT

THIRUMAYAM- 622 507

CONTRACTS DEPARTMENT

Phone : 04333279551

E.mail : ilango@bheltry.co.in Website : www.bhel.com

Tender No:PPPU:WC:14:015

Tender Notice

Dt. 04.10.2014

(iii) Machine Mixing For large works, machine mixing will be necessary to ensure sufficient outturn to enable each unit of the system to be laid continuous by eliminating or minimizing the number of construction joints. The contractor shall arrange the size of machine mixer and operating plant accordingly. I.S. 456 : and 1791 : shall also apply.

6. Consistency : (i) Paragraph 5.3. of I.S. 456 : shall apply

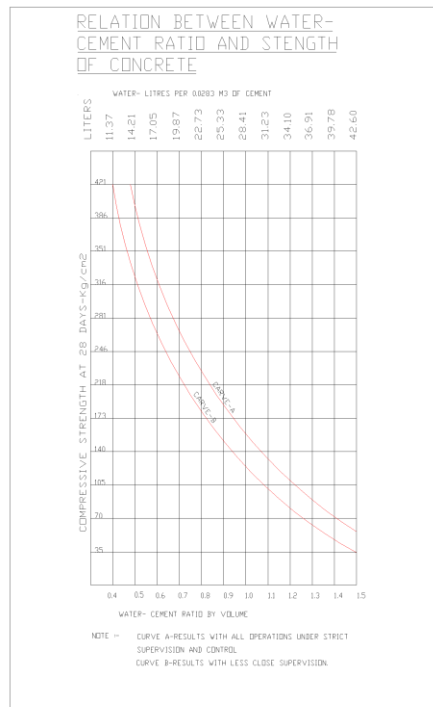

(ii) Slump test – The slump, is the amount of settlement in cms. Obtained after filling with concrete a standard metal cone form, of 10 cm. Top diameter, 20 cm. Bottom diameter, and 30 cm. High and then removing the form. The filling should be done in layer approximately 7.5 cm high, each layer being punned 25 times with a 16 mm in diameter rod, bullet pointed at one end. The less the slump and consequently the stiffer the mixer provided that it is workable, the stronger will be the concrete, other conditions being equal. The smallest slump that will give a consistency suitable for the work in hand should be used. The recommended values for the slumps are :

		When used	vibrator	Not used
--	--	-----------	----------	----------

Place
Date

Signature of the Bidder
(NAME & ADDRESS WITH SEAL)



BHARAT HEAVY ELECTRICALS LIMITED

POWER PLANT PIPING UNIT

THIRUMAYAM- 622 507

CONTRACTS DEPARTMENT

Phone : 04333279551

E.mail : ilango@bheltry.co.in Website : www.bhel.com

Tender No:PPPU:WC:14:015

Tender Notice

Dt. 04.10.2014

1.	Mass concrete in foundations footings, retaining walls and pavements	10 mm to 25 mm	30 mm to 75 mm
2.	Thin flooring of less than 75 mm thickness	25 mm to 40 mm	75 mm to 100mm
3.	Mass concrete in R.C.C. foundation footings and retaining walls	10mm to 25mm	80mm
4.	Beams slabs and columns simply reinforced	25 mm to 40 mm	100mm to 125 mm
5.	Thin R.C.C. section or Section with congested steel	40mm to 50 mm	125 mm to 150 mm

- (iii) In the case of pipes or similar articles where the space to be filled is narrow and confined, a concrete that will flow readily has to be used, but care must be taken to eliminate the entrapped air bubbles.
- (iv) Some experiments indicate that every ½ Kg. Weight of excess water used has the same effect on strength, as to the omission two kilograms (or more) of cement.
- (v) Excess of water not only causes loss of strength, but also involves increased shrinkage and liability to cracking.
- (vi) A working mean to get best strength and workability has to be adopted to enable the use of the direst possible concrete that can be worked successfully around and between the steel bars so as to thoroughly envelop all of them, and leave no voids and hollows. With insufficient water, the chemical action in setting will be adversely affected.
- (vii) The diagram appended is illustrative of the effect of water on the strength of concrete.

7. Mix design :-

- (a) For works in which water tightness is required the specifications laid in I.S. 3370 I to II shall apply.

8. Forms and centering – (a) A constructional load of 400 Kg / m² in addition to the dead weight of the concrete may be assumed in designing the centering. The forms shall be carefully designed and the design shall be subject to the approval of the Executive Engineer, who may require the contractor to alter the designs in accordance with instructions, or adopt designs prepared by him without extra cost. If wooden centering are adopted only well seasoned timber should be used in their construction. It is better use too thick, than too thin timber as it is false economy to use light forms, which will not lend itself for frequent removal and re erection. Under no circumstances should green timber be used, as it is liable to shrink after erection.

Place
Date

Signature of the Bidder
(NAME & ADDRESS WITH SEAL)



BHARAT HEAVY ELECTRICALS LIMITED

POWER PLANT PIPING UNIT

THIRUMAYAM- 622 507

CONTRACTS DEPARTMENT

Phone : 04333279551

E.mail : ilango@bheltry.co.in Website : www.bhel.com

Tender No:PPPU:WC:14:015

Tender Notice

Dt. 04.10.2014

- (b) If the forms are held together by bolts or wires they shall be so fixed that no iron will be left exposed on the face of the finished work.
- (c) All centering and supports shall be properly braced and cross – braced in two directions and well stayed or strutted on all sides rigidly enough to resist storm, or high winds during execution. The forms should be strong enough to withstand the weight or pressure when a considerable height of wet concrete is being poured, as in walls or columns. Many authorities suggest that pressure may be taken as caused by a liquid of half the weight of concrete, namely $1,200 \text{ Kg / m}^3$
- (d) For joints and gaps, paragraph 20 : 2-1 of I.S. 456 shall apply
- (e) To ensure that all faces of concrete which will be exposed to view on completion of the work have smooth finish, beveled edge timber (tongued and grooved, if so specified or ordered) shall be used, giving smooth tight joints.
- (f) In special cases, the surfaces that are to come in contact with concrete should be planed flat and smooth and be free from know holes and other imperfections. Oiling or greasing of forms shall not be done if the concrete is to receive a coat of plaster after removal of the forms. I.S. 456 shall also apply
- (g) Old forms, or forms left long exposed to weather should be examined carefully before re-use.
- (h) The centering should be so designed and arranged that the sides of columns can be first removed, then the sides of beams, then boarding under the floor slabs and lastly the soffits of beams
- (i) Where the centering posts rest on soft ground, the load should be got distributed by means of sleepers or short piles; otherwise the supports may punch into the ground, causing a sag and settlement and possibly cracks in beams and floor slabs. All uprights should be provided with a double set of wedges or sand boxes, so that they may be gently removed. The section of the scantling from which the wedges are cut should be at least 10 cm by 10 cm.
- (j) When the concrete is placed in layers' no calculation necessary as it has been found in practice that for beams, the bottom boards should be 5 cm to 6 cm thick with sides 4 cm to 5 cm thick, for columns sides should be 4cm to 5cm thick and for walls 4 cm boards are generally used. The thickness can be varied according to the spacing of the clamps or braces but on this account the material should be made too thin. For slab panels 2.5 cm . board is generally used which require staying every 60 cm. 4 cm. Boarding will require staying every 90 cm. And 5 cm. Boarding every 1.2 m to 1.5 m. The studs i.e., the vertical pieces on which the sheathing or planking is nailed, should be of such a size and be so spaced as to prevent the boards between them from springing.
- (k) For square columns three sides of the form should be bolted or clamped together and the fourth side left open and braced at intervals sufficient to keep the box or casing in shape. This open side should be gradually built up a little advance of the concrete laying. For this purpose, strong timbers fixed with wedges behind vertical runners should be used.

Place
Date

Signature of the Bidder
(NAME & ADDRESS WITH SEAL)



BHARAT HEAVY ELECTRICALS LIMITED

POWER PLANT PIPING UNIT

THIRUMAYAM- 622 507

CONTRACTS DEPARTMENT

Phone : 04333279551

E.mail : ilango@bheltry.co.in Website : www.bhel.com

Tender No:PPPU:WC:14:015

Tender Notice

Dt. 04.10.2014

- (l) Other shapes of columns must all be filled from an open side in the form to allow the steel to be kept in its proper position, the structure to be gradually built up and the concrete properly and thoroughly consolidated.
- (m) A completely enclosed form should not be used as it will necessitate filling in of concrete from a considerable height and prevent the casting of concrete from being properly inspected or compacted.

9. Laying concrete – (A) General (i) Paragraph 20-21 of I.S. 456 shall apply.

- (ii) Usually it will be found preferable to completely fix the reinforcement for the whole floor, before beginning to place concrete.
- (iii) Suitable wooden plugs may be placed in the centering for electric fittings. Similarly clamps for hanging ceiling fans or sewing planks should also be fixed in their correct positions. In all such cases where fixed blocks are embedded, care should be taken to see that the strength or effective cover of any part of the structure is not reduced below the standard required by this specification.
- (iv) Electrical Conduits to be placed in Concrete Beams and Slabs – Where conduits are to be cast in concrete slabs, the boxes and conduits are installed and held in position by blocks and iron wire fastened to the reinforcing bars. The concrete is then poured and tamped. For structural reasons these runs of conduit are usually close to the bottom surface or near the central portion of a floor slab. If a great number conduits must be embedded it may be necessary to increase the slab thickness. This refers of course, to conduits being installed in a structural slab. In many instances, the structural slab is covered with a concrete topping or fill in which the conduit may be installed without affecting the integrity of the slab. In all cases, local building codes should be consulted for limitations, or imbedded conduits. In any event the top of any conduit shall be least 18mm below the finished floor surface in order to prevent cracking. When heavy trucking is expected, this allowance should increased 1 ½ minimum

- (1) Conduits shall have an OD not greater 1/3rd of thickness as measured at its thinnest point
- (2) Conduits running parallel to each other shall be spaced not than 3 times the OD of the largest conduit center to center.
- (3) Conduits running parallel to beam axis, shall not run above beams
- (4) Conduit crossings shall be as near to a right angle as possible.
- (5) Minimum cover over conduits shall be 18 mm.

(B) Handling – Para 20: 1-3 and 20:1-4 of I.S. : 456 shall apply

(C) Placing and vibration of concrete – I.S. 456 shall apply

- (a) Where the sections of concrete members are thin and very heavily reinforced, carefully executed vibration, either alone combined with tamping, causes the concrete to flow uniformly round bars. Moreover, the increased fluidity due to vibration occurs that with mixes which would otherwise be regarded as too dry for

Place
Date

Signature of the Bidder
(NAME & ADDRESS WITH SEAL)



BHARAT HEAVY ELECTRICALS LIMITED

POWER PLANT PIPING UNIT

THIRUMAYAM- 622 507

CONTRACTS DEPARTMENT

Phone : 04333279551

E.mail : ilango@bheltry.co.in Website : www.bhel.com

Tender No:PPPU:WC:14:015

Tender Notice

Dt. 04.10.2014

reinforced concrete work. In consequence, in work where a low water cement ratio would be necessary, with hand tamping, higher strength may be obtained by vibration due to the drier concrete, it can be used and compacted with these machines.

- (b) All beams and slabs shall be filled to the top surface in one continuous operation, that is from the bottom of beam to top of floor.
- (c) For vertical joints in long buildings – Part 19, of I.S 456 shall apply
- (d) In cases where the outer faces of buildings are plastered the reinforced concrete roofs should be as a rule, be carried through to the outside of walls and a small parapet built over them. In cases where the outer faces of buildings are pointed, the reinforced concrete roofs may be stopped short for the face by half a brick or a full brick and the face so left on the wall built up with bricks to suit the pointing over the rest of outer face. If leakage through the joint between the end of roof slab and masonry is anticipated the joint at weep holes shall be filled with an asphaltic composition and covered with flat tiles before building on the parapets.

(D) Treatment at bearings of reinforced concrete slabs and beams

- (a) The principle underlying the treatment at bearings of R.C.C. slabs and beams, is to effectively insulate the R.C.C. structures from the masonry or other supports on which they bear.
- (b) The vertical face of the masonry rebate at bearings should also be plastered smooth with cement mortar 1:3. A gap 12mm wide should be left between the vertical face of the masonry and the R.C. work and this gap should be filled with a mastic. Composition of bitumen for caulking purposes given in the I.S. 1580 shall apply. Composition specification for mastic given in I.S. 5057 and for bitumen felt in I.S. 1322 shall apply. The object of fillings is to minimize chances of stone chips or other hard materials inadvertently falling into the gap and getting wedged between the R.C.C and masonry, thus obstructing free movement. Where the spaces will not be easily

accessible for mastic filling after the concrete is laid, as for example, at sides of a tee-beam with slab extending to full length of the beam at the bearing, pre cast pads of the mastic 12mm. thick could be inserted before laying the concrete. The mastic filling of pad should not extend to full depth of the gap but a space of say 25 mm to 40 mm should be left vacant at top in order to admit of the mastic being squeezed when the slab or beam moved against it. Similarly, the mastic should be stopped about 40mm away from the vertical face of walls to ensure the walls being finished with plaster.

- (E) (a) Finishing the concrete surface – Best results at least cost are obtained when the finishing is undertaken while the concrete is still green. The fins and any rough projections can then be rubbed down and the whole surface brought to an even finish by rubbing with a wooden float using a mortar at the same time filling the

Place
Date

Signature of the Bidder
(NAME & ADDRESS WITH SEAL)



BHARAT HEAVY ELECTRICALS LIMITED

POWER PLANT PIPING UNIT

THIRUMAYAM- 622 507

CONTRACTS DEPARTMENT

Phone : 04333279551

E.mail : ilango@bheltry.co.in Website : www.bhel.com

Tender No:PPPU:WC:14:015

Tender Notice

Dt. 04.10.2014

voids. A neat cement work shall then be applied to give a smooth surface. If the concrete has set hard, the fins and rough projection, if any, shall be removed by using corborandum brick or a paved grinding machine by chipping, before finishing off with the smoothing wash. If the work of chipping is not done with care or if the surface exposed after removal of the forms can not be satisfactorily dealt with in this manner due to bad form work or for other reasons, a coat or cement plaster of 1:2 of thickness as ordered by the Executing Engineer shall be applied. No extra payment will be given for finishing concrete surfaces as instructed above in this clause. However, for work where the finishing of R.C.C. surface with plaster coat is found necessary for asthetic beauty, the authority calling for tender should furnish a supplemental specification indicating the thickness and proportion of mortar to be used for the plaster coat over the R.C.C. concrete surface and also the method of payment in the schedule of tender notice.

- (b) Weathering course over the R.C. slab – In the case of buildings, where there is no storey over it, the R.C. slab is to be protected against alternative shrinkage and expansion. For this a weathering course of brick jelly concrete is laid over the slab. After fifteen days of the laying of R.C. slab, for every 1 m³ of weathering course a layer of brick concrete 100mm thick with 0.96 m³ broken brick 20mm gauge and 0.375 m³ slaked lime (no sand) shall be laid over and well beaten to 75 mm thickness with wooden hand beaters. Necessary slope to drain the rain water shall also be given in the weathering course itself. The beating shall continue until the concrete is well consolidated and the beater makes no impression and readily rebounds from the surface when struck on it, the whole shall be constantly wetted by sprinkling lime water. Should this surface, during the process of beating become so uneven that water lodges, it shall be picked up and fresh concrete added as may be necessary.

(After six days or after the concrete laid has hardened, one course of pressed tiles of size 20 cm. X 20 cm X 20 mm shall be laid in oiled mortar in C.M. 1:3 and rubbed smooth

- (c) Payment for treatment at bearings of reinforce concrete slabs and beams should be made separately and not included in rate for R.C. Work

Joints in buildings : - The various of joints that may have to be installed in buildings are as follows :

1. Expansion joints : Joints provided to accommodate the expansion of adjacent parts and relieve compressive stress that may otherwise develop.
2. Construction Joint – Joint installed at location whose construction stops for any reason.

Place
Date

Signature of the Bidder
(NAME & ADDRESS WITH SEAL)



BHARAT HEAVY ELECTRICALS LIMITED

POWER PLANT PIPING UNIT

THIRUMAYAM- 622 507

CONTRACTS DEPARTMENT

Phone : 04333279551

E.mail : ilango@bheltry.co.in Website : www.bhel.com

Tender No:PPPU:WC:14:015

Tender Notice

Dt. 04.10.2014

3. Contraction Joints : These are separation or plans of weakness introduced in concrete structure to localize shrinkage movements
4. Sliding joint or vertical joints : - When variation in temperature, moisture content, or loading results in unequal settlement or movement in different parts of the building vertical joints are formed so as provide as slip plane.
5. Spacing of expansion joint : - (1) Roof R.C.C. 20mm interval and at changes in direction
6. Vertical joints may be located at 30 m intervals in long uniform structures and at junction of L.H. and T shaped structures.
7. Joints may be provided at every 10 m for parapets compound wall, chajja and balconies
8. Expansion joint in R.C.C. roof slab or floor slab with or without R.C. beams -- The expansion joint should span in the same direction as that of the main reinforcement. In case the site conditions require the joints to be spanned across the main reinforcement, necessary beams should be introduced at the joints to support the slab. A typical sketch of the expansion joint in R.C.C. roof slab is enclosed. The same can be adopted for floor slabs by omitting the raised portion above the R.C.C. slab. The avoid cracks in the supporting masonry below and in the cases where it is not possible to provide a vertical joint in the masonry, it is preferable to provide cement concrete bed block on the bearing. In the case of joints in the floor slabs over R.C.C. column the copper sheet can be perforated with slotted holes or groves and inserted over the reinforcement and the joint finished as usual.
9. "Method of formation" Type 'A' – While laying the slab, the water bar is placed in its position and tied with the slab reinforcement grill. While concreting the ends of the slab the joints are given increased thickness by giving a slope of 1 in 12 for 60 cm width, on both sides and raised to 30 cm as shown. The top and sides are finished smoothly. (it is not advisable to raise this portion by masonry , as masonry will separate from R.C. slab during expansion and there is likelihood of rain water leaking through the separate crack)

The weathering course are then laid and furnished as shown in the raised portion. At the top of one side of the raised portion an asphalt pad or tar felt is placed. The joint is then covered at top with two courses of pre cast cement concrete slabs of mix. 1:2:4 and 2.5 cm thick in staged manner. The top course of slabs is given a slope of 1cm (in 50 cm width) by adjusting the thickness of mortar between the two course of cover slabs as shown in the sketch.

A.C. sheet is fixed at the bottom of the joint with suitable screws and plugs. The ends of the joint are also finished smoothly.

Place
Date

Signature of the Bidder
(NAME & ADDRESS WITH SEAL)



BHARAT HEAVY ELECTRICALS LIMITED

POWER PLANT PIPING UNIT

THIRUMAYAM- 622 507

CONTRACTS DEPARTMENT

Phone : 04333279551

E.mail : ilango@bheltry.co.in Website : www.bhel.com

Tender No:PPPU:WC:14:015

Tender Notice

Dt. 04.10.2014

Type 'B' –While concreting, the ends of slab at the joint are given increased thickness, by giving a slope 1 in 12 for 60 cm width, on both sides, from the edge of the joint and raised to 30 cm. As shown . The top and sides are finished smoothly. (It is note advisable to raised this portion by masonry, as masonry will separate from R.C slab during expansion and there is likelihood of rain water leaking through the separated crack)

Weathering course (viz) brick jelly lime concrete and flat tile or pressed tiles as the case may be, are then laid and pointed as shown in the sketch.

A.C. Sheet is then fixed at the bottom of the joint with suitable screws and plugs. The joint is then filled up with suitable back up materials like, plastics, cork strips, granulated cork, board, dehydrated cork, fiber board , flexible foam, or rope, etc. as shown in the sketch, up to 1 cm below the top of the raised portion of the joint. A bond breaker such as polyethylene strip should be use in case the sealant has adhesive tendency to the bottom of the joint or to the back-up material. The sides of the joint should be absolutely free from moisture, oil, dust, loose particles, etc., Damp joints may be dried by the use of gas torch, or hot air blower. Dust may be removed by wire brush. The primer is a two component system with a base and a hardener, mixed at a suitable proportion mentioned by the manufacture. Adequate time as stipulated by the manufacturer may be allowed for the primer to set.

The space at the top over the backup material and between the dried primer sides is the filled up with the sealant. Sealant compound application should be completed within the life period stipulated by the manufacturer.

At the top of one side of the raised portion an asphalt pad or felt is placed. The joint is then at the tope with two courses of pre cast cement concrete slabs of mix. 1:2:4 and 2.5 cm thick in a staggered manner.

The top course off slab is given a slope of 1 cm (in 50cm) width by adjusting the thickness of mortar between the two courses of cover a slabs as shown in the sketch”.

Place
Date

Signature of the Bidder
(NAME &ADDRESS WITH SEAL)



BHARAT HEAVY ELECTRICALS LIMITED

POWER PLANT PIPING UNIT

THIRUMAYAM- 622 507

CONTRACTS DEPARTMENT

Phone : 04333279551

E.mail : ilango@bheltry.co.in Website : www.bhel.com

Tender No:PPPU:WC:14:015

Tender Notice

Dt. 04.10.2014

SECTION V. BRICK MASONRY.

INDIAN STANDARDS EXTRACTS.

I.S. Numbers	Description
4082	Recommendations on Stacking and Storage of Construction Materials at site
1077	Specification for Common Burnt Clay Building Bricks
3102	Classification of Burnt Clay Solid Bricks
2691	Specification for Burnt Clay Facing Bricks
2212	Code of practice for Brick Work
1905	Code of practice for Structural Safety of Buildings ; Masonry Walls
2117	Code of practice for Manufacture of Hand Made Common Burn Building Bricks
1200	Method of Measurement of Building and Civil Engineering Works (Part-III) Brick Works

SPECIFICATION No.31 BRICK MASONRY GENERAL

1. Wall bricks : -

1.1. Specification for building bricks and classification are covered I.S. 1077 / 1970 and 3102 / 1971.

N.B. Vide descriptive specification sheet to be attached to agreement regarding kilns from which bricks are to be obtained.

2. Bricks are to be well soaked in water before use. For further instructions regarding soaking and size of bricks to be used I.S. 2212 / 1962, and I.S. 1200 Part III / 1970 shall apply.
3. Regarding making of bricks I.S. 2117 / 1967 shall apply. Where a large number of brick has to be manufactured it would be prudent to mould and burnt a small number on trial ensure the certainty of the output before starting operations on a large scale.

Place
Date

Signature of the Bidder
(NAME & ADDRESS WITH SEAL)



BHARAT HEAVY ELECTRICALS LIMITED

POWER PLANT PIPING UNIT

THIRUMAYAM- 622 507

CONTRACTS DEPARTMENT

Phone : 04333279551

E.mail : ilango@bheltry.co.in Website : www.bhel.com

Tender No:PPPU:WC:14:015

Tender Notice

Dt. 04.10.2014

- 3.1. All fuel for brick burning should be dry and used when comparatively fresh. Decayed timber should not be used as fuel., Tamarind or babul is the best wood to use in burning. Specification for facing brick is covered by I.S. 2691 / 1972.
4. Mortar : - Specification is covered by I.S. 2212 / 62. Should the mortar perish, i.e., become dry white or powdery through neglect of watering, the work shall be pulled down and rebuilt at the contractor's expense, or should the contractor fail to watch the work to the satisfaction of the officer – in - charge of the work the latter may supply the requisite men to water the work properly and charge the cost to the contractor.
- 4.1. All masonry shall be washed down on completion and all stains – lime or otherwise – removed from the face
5. Bats : No bats or cut bricks shall be used except where absolutely required for obtained the dimensions of the different courses for obtaining the specified bond and where in the opinion of the Executing Engineer the work is of too petty a nature to warrant the special moulding of bricks of the shape required,
- Setting bricks in mortar, bond and raking of joints are covered by I.S. 2212 .
6. Non – plastered face work : Finishing joints is discussed in para 5.5. of I.S. 2212. Where is no specification superseding the standard specification "Pointing – Remarks on " non – schedule provision made for extra payment for pointing, the exposed joint shall be finished as described under clauses 1 to 4 of "Pointing remarks on " and shall be well rubbed with a piece of 10mm rod suitably bent.
- 7.1. No extra payment will be made for this manner of finishing brick work face joints and it shall be included by the contractor in his unit rate for brick work.
7. Racking back _ When circumstances render it necessary to carry on the same section of t he building in uneven course the bricks shall be raked back so as to maintain an uniform and effectual bond.
8. Iron, stone concrete and other fixtures, buttresses, etc., Vide clause 16 under standard specification for stone masonry general which is to complied with.
9. Wet formations : - vide clause 17 under stone masonry general which is to be complied with.
10. Openings – This is covered by paras 10.2, 10.4, of IS 2212
- 11.1. The contact unit rates for brick work are inclusive of quoin and jambs.
11. Treating – This is covered by paras 5.12 and 5.12 of I,S, 2212 .

Place
Date

Signature of the Bidder
(NAME & ADDRESS WITH SEAL)



BHARAT HEAVY ELECTRICALS LIMITED

POWER PLANT PIPING UNIT

THIRUMAYAM- 622 507

CONTRACTS DEPARTMENT

Phone : 04333279551

E.mail : ilango@bheltry.co.in Website : www.bhel.com

Tender No:PPPU:WC:14:015

Tender Notice

Dt. 04.10.2014

12. Treatment at ends of beams and joists – The ends of all wooden beams wooden roof trusses, etc., shall rest in recess having 40 mm space for the free circulation of air all – round them and provided with perforated zinc sheeting.
13. Measurement of brick work is covered by I.S. 1200 part – III.

Measurements _

- (i) Brickwork shall generally be measured in cubic metres unless other-wise specified.
- (ii) Walls half brick in width and less shall be measured separately in square metres stating thickness
- (iii) Brick walls of width over half brick shall be measured in multiplies of half brick which shall be deemed to be inclusive of mortar joint, irrespective of excess of executive width.
- (iv) The following shall be taken as half brick measurement.

For bricks 19 x 9 X 9 cm – 10 cm

For bricks 19X9 X 5.7 – 10 cm.

14. Wooden bricks – No extra piece will be paid for wooden bricks and plugs built into masonry, the wooden bricks and plugs themselves are to be supplied free of charge. Clause 14 under stone masonry “General” is to be complied with.
15. Stacking – This is dealt with in I.S., 4082
16. Handling bricks – Bricks shall not be handled in baskets or in other manner which will destroy the sharpness of their edges.
17. Checking of levels – The Sub Divisional Officer will personally verify all levels with a leveling instrument when the work reaches the level of the plinth and again at floor and roof levels.
18. Rounding corners – (a) Corners of rooms or pillars whether interior or project shall not be rounded but in exceptional cases, where it is so desired to round the corners shall be done in plaster for the re – entrant corners but will require chiseling of projecting angles before plastering.
(b) A separate addendum specification will be issued in case specially moulded rounded corner bricks are to be used in jambs aches and projecting and reentrant corners so as to eliminate the sharp angles.
(c) The rate tendered for plastering and brick work in the case (a) and (b) above shall be held to cover the cost of labour and materials for complying with this clause.
19. Brick on edge coping, etc: PARA 10.1 OF I.S. 2212 shall apply, No extra payment will be made for this work, over the contract rate for brick work. The contract rate for brick work shall include the same .

Place
Date

Signature of the Bidder
(NAME & ADDRESS WITH SEAL)



BHARAT HEAVY ELECTRICALS LIMITED

POWER PLANT PIPING UNIT

THIRUMAYAM- 622 507

CONTRACTS DEPARTMENT

Phone : 04333279551

E.mail : ilango@bheltry.co.in Website : www.bhel.com

Tender No:PPPU:WC:14:015

Tender Notice

Dt. 04.10.2014

20. Plinth off-sets on the interior faces only should be kept 15cm below floor level (unless finished thickness of floor to be laid will determine, instead of the 15cm) to allow for the floor paving which is done subsequently coming upto the face of the superstructure. Similarly retaining walls of verandahs, etc., must be built with due regard to the slope allowed for the floors.
21. Parapets: All parapets will be measured under the masonry below them and with which they are continuous in a floor, the parapet has to be reckoned with the lower floor (Circular Memo. 6105/A6/53-2, dated 2nd December 1953).
22. Anti-termite constructional methods: At places of foundation where the existence of colonies of subterranean termites are found the probability of internal attack of termites through floor and plinth fillings is great. In such places the constructional practices for protection against subterranean termites originating both internally from plinth and externally from the area surrounding the building as laid down in IS 6313 (Part-I) be followed.
23. Applicability of General specification: General clauses shall apply to all the following sub-specification of brick masonry.

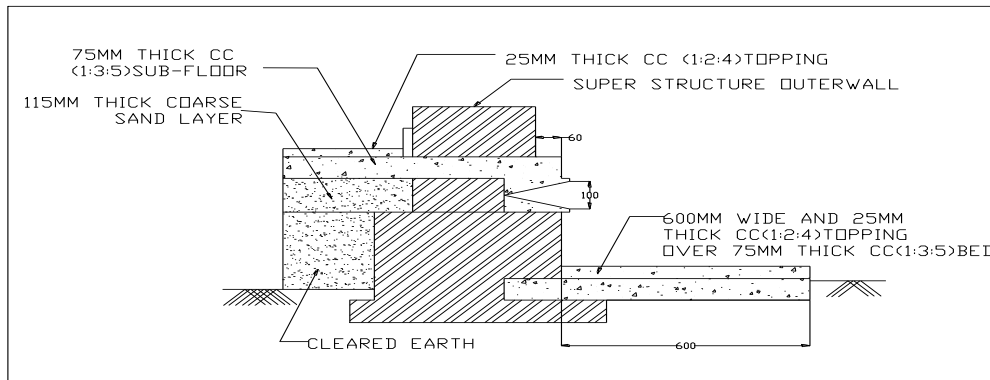

1. If bricks, specially moulded to the radial lines of the arch, are demanded for arch work it will be so specified. If any case, the bricks shall be specially selected and shall be free from defects of any sort.
N.B. Specially moulded bricks are always preferable as cutting and rubbing of bricks to give proper radial joints remove the hard surfaces skin which protects the bricks from decay and weathering. The cost of labour, required for rubbing the bricks, will in important works come to as much as providing specially moulded bricks, in which cases it will be advisable for the contractor to provide, the same whether specified or left to his option in supply.
2. The bricks shall be laid in concentric half – brick rings. The voussoir joints shall be properly summered. The thickness of joints shall be the same as that specified in the

Place
Date

Signature of the Bidder
(NAME & ADDRESS WITH SEAL)



BHARAT HEAVY ELECTRICALS LIMITED

POWER PLANT PIPING UNIT

THIRUMAYAM- 622 507

CONTRACTS DEPARTMENT

Phone : 04333279551

E.mail : ilango@bheltry.co.in Website : www.bhel.com

Tender No:PPPU:WC:14:015

Tender Notice

Dt. 04.10.2014

standard specifications for the same class of brickwork in mortar. In all arches, the voussoir joints shall be truly perpendicular to the tangent of the curve at those points. In setting the bricks in arches, they shall be well pressed into their beds so as to compress the mortar to full bearing and leave the joint thin.

3. Bricks forming skew-back joints shall be specially mould or cut, so as to radiate truly, and defects in this particular shall not be remedied by the extravagant use of mortar, nor shall patching up by chips, etc., be permitted
4. Great care shall be taken that the rings are bonded together properly wherever the joints of any of the rings come to a summering or planer face. Joints in two consecutive rings shall not come in the same radial plane. The arch work shall be evenly and quickly done and kept thoroughly moist so that no portion of the arch hardens or sets before the whole arch is completed
5. Centers shall comply with clause 4 for Centers under the standard specifications for "Ashlar Arching".
6. Arch work over doors and windows shall be built to this specification, segmental arches being given the rise indicated in the following table :
7. When flat arches are specified, a relieving arch is to be built over the flat arch. The chamber for the flat arch will be 10mm per metre of span. The relieving arch must first be built with above precautions regarding centers, etc. and not simply built with above precautions regarding centers, etc., and not simply built into the wall over the masonry laid to the segmental shape. Skew – back of the flat arch. The space between relieving arch and a flat arch or lintel is not to be filled until the wall has been completed, unless specially ordered by the Executive Engineer. Flat arches will be formed of carefully rubbed brick in header and stretcher bond with all voussoir joints converging to the apex of an equilateral triangle described on and below the soffit of the arch. Flat arches will usually only be used for pointed face work.

SPECIFICATION NO. 31 E BRICK WORK IN CLAY

Mud mortar of the same specification as described in the standard specification "Random Rubble in Clay" shall be used. The bricks shall be the best of the class specified

Work shall be carried out to the Standard specification with the exception that clay replaces mortar. Joint thickness should not exceed 1.25 cm. The bricks also require comparatively little wetting prior to use nor need they be subsequently kept damp as specified for brick in lime mortar. As the back work will usually be plastered less labour will be required for finishing off joints of the brick work.

It is customary with this class of masonry in Buildings, to execute the top 30 cm. around doors and windows with brick in lime mortar or cement mortar.

SPECIFICATION NO. 32

Place
Date

Signature of the Bidder
(NAME & ADDRESS WITH SEAL)



BHARAT HEAVY ELECTRICALS LIMITED

POWER PLANT PIPING UNIT

THIRUMAYAM- 622 507

CONTRACTS DEPARTMENT

Phone : 04333279551

E.mail : ilango@bheltry.co.in Website : www.bhel.com

Tender No:PPPU:WC:14:015

Tender Notice

Dt. 04.10.2014

HONEY COMB WORK WITH BRICKS AND PLASTERED ONE COAT 10MM LIME MOTAR INCLUDING WHITE WASHING TWO COATS

1. Modular bricks shall be used unless other class of bricks are expressly specified in the schedule item description. The bricks shall be thoroughly bedded with lime mortar and have a bearing of 20mm on each side.
2. The wall shall be 20 cm thick. The bond used shall be a heading bond throughout the wall with rectangular shaped holes.
3. The faces and sides of the holes shall be plastered with lime mortar one coat to that standard specification only with thickness 10mm, and the rate is to include plastering, All joints and edges shall be struck flush to give even surface on all sides
4. Watering shall be done for one week after completion of the masonry and prior to white washing
5. Two coat of white wash shall be finally applied to both faces of the work and also to the interior of the holes. This included in the unit rates. The wall shall be carried up regularly course by course

Note : Cement mortar can also be used instead of lime mortar

SPECIFICATION NO.33

HONEY WORK WITH WASHED PAN TILES

1. Standard specification pan tiles are to be used or such other size as may be specified or instructed to be used by the executive Engineer. In no case tiles of different dimensions be used on the same work
2. The tiles shall be soaked in water for 24 hours and allowed to dry, After they are quite dry they shall be dipped in standard specification white wash of the consistency of cream and again allowed to dry .
3. The tiles should then be laid in regular rows with concave surface downwards with sufficient mortar at the joints to prevent the tiles from displacement. The tiles in each row shall be built in so that each tile covers the joint between two tiles in the row immediately below. Broken tiles shall never be used on the work.

SPECIFICATION NO. 34.

REINFORCED BRICK WORK WALLS

1. The walls shall be built of modular bricks in Standard Specification cement mortar being in the proportion of 1 of cement to 3 of sand. The reinforcement shall consists of hoop iron 40mm wide and 15 gauge or such other size as may be specified laid flat in the middle of the brickwork. (The bond of the hoop iron with the brickwork will be greatly improved if the hoop iron is punched at intervals of say 15 cm. So as to form burrs on both sides of the reinforcement. The punch hole shall be 6 mm diameter) .
2. The strip of hoop iron shall be continuous and if it is not available for the full length it shall be revert – jointed with an overlap of not less than 8 cm. AT the ends the strips shall be

Place
Date

Signature of the Bidder
(NAME & ADDRESS WITH SEAL)



BHARAT HEAVY ELECTRICALS LIMITED

POWER PLANT PIPING UNIT

THIRUMAYAM- 622 507

CONTRACTS DEPARTMENT

Phone : 04333279551

E.mail : ilango@bheltry.co.in Website : www.bhel.com

Tender No:PPPU:WC:14:015

Tender Notice

Dt. 04.10.2014

folded over at the function to atleast half the depth of the course. It shall be placed at every alternate course or as may be otherwise specified or as shown in the drawing Before laying the hoop iron it should be exposed to the weather to remove its bluish smooth surface and hereby increase its adhesion to the mortar.

3. Two slots at least 10 cms. Deep should be cut in the walls between which the partition has to be built and the partition shall be built into these slots, the slots being flushed full joint with cement mortar 1:3 as the work proceeds.
4. The thickness of the wall will be width of a standard specification size brick, unless other size brick is permitted by the Executing Engineer to be used – Plus the plaster thickness for the two faces.
5. The joints should not be more than 6 mm except where the hoop iron is to be laid, where the joint should be 25 mm., thick to ensure at least a cover of 12 mm between the reinforcement and the bricks. The face joints shall be raked out to 12mm. depth before the mortar completely.
6. The wall shall be finished with standard specification cement plastering 1:5, 12 mm thick on both faces and watered for three weeks.
7. Two coats of standard specification 'White washing' shall then be applied.
8. The rate shall be for 10 square metres inclusive of reinforcement cutting slots in end walls, plastering, white washing etc., completely finished in place.

NOTE : (1) These walls are intended to be introduced in places where there are no walls or beams or such other foundation underneath and they are generally expected to act as a beam by themselves and to be held up by the side walls.

2. For the purposes of correct reinforcement it is necessary to lay most of the iron in the bottom courses farthest from the neutral axis of the wall treating it as a beam and to reduce the reinforcement proportionately upto the neutral axis and to have no iron in the compression courses above the neutral axis but to render the wall safe against any lateral shock of stress, reinforcement is taken upto be top.

Note on protection against – X –Rays in Institutions –

9. General – The following instructions shall be followed in the construction of all radiological institutions where it is necessary to provide adequate protection to the operators and other personnel engaged in the X-ray work from the harmful effects of X-Rays. In view of the danger to the health of occupants, if any mistake are committed in applying the protective measures, it is specially warned that the precautions should be carefully studied and put into effect. The extent of protection that is required will depend upon the potentiality of the equipment to be housed. Requirements or various forms of X-Ray work are laid down in terms of thickness of lead in millimeters the report of the X-Ray and Radium Protection committee.

	X-Ray generated by peak voltage in KV	Minimum equivalent thickness of lead In millimeters
Not Exceeding	75	1.0
"	100	1.5
"	125	2.0

Place
Date

Signature of the Bidder
(NAME & ADDRESS WITH SEAL)



BHARAT HEAVY ELECTRICALS LIMITED

POWER PLANT PIPING UNIT

THIRUMAYAM- 622 507

CONTRACTS DEPARTMENT

Phone : 04333279551

E.mail : ilango@bheltry.co.in Website : www.bhel.com

Tender No:PPPU:WC:14:015

Tender Notice

Dt. 04.10.2014

"	150	2.5
"	175	3.0
"	200	4.0
"	250	6.0
"	300	9.0
"	350	13.0
"	400	17.0
"	500	26.0
"	600	35.0
"	700	44.0
"	800	53.0
"	900	62.0
"	1000	70.0

9.1. These requirements shall be met by special requirements in construction as detailed below :

- 9.1.1. Walls – Walls shall be constructed of special barium impregnated bricks. These bricks shall be made by mixing dry 8 parts by volume of clay absolutely free from any pebbles and vegetable matter and one part by volume of barium sulphate. In order to ensure proper mixing, not more than 0.5 m of clay shall be taken up in a heap for mixing at a time. All such heads are then collected together into a big heap and a pit formed in it. The requisite quantity of water shall then be poured in the pit slowly and the whole allowed to remain for 12 hours after which the mixture shall thoroughly plugged. Bricks shall then be moulded in a mould of standard size but having special arrangement to leave V-shaped grooves, at the least 3 mm. deep on all the four edges of the bricks to distinguish them from ordinary bricks. The bricks so prepared shall be burnt as ordinary bricks and shall be laid in lime mortar to which barium sulphate is added in the proportion of 8:1 by volume. The thickness of barium – impregnated brick walls shall be as required by the graph appended to this specification. For wall 30 cm thick barium impregnated bricks will be used for the full thickness and in walls of more than 30 cm thickness. barium impregnated bricks will be used for 30 cm. And 40 cm. Widths, in alternate courses and the balance in thickness will be built with ordinary bricks in ordinary mortar.
- 9.1.2. Wall – Plastering – All the walls of barium impregnated bricks shall be plastered with special mortar of the following mix, viz., cement 1, sane 1, barium sulphate 3, by volume. The thickness of plaster shall be 15 mm to 20mm lid in the same manner as two coats of ordinary lime plastering
- 9.1.3. Floor and ceiling – Floor projection shall be given by paving with barium bricks laid flat in cement barium mortar (1 cement 1 sand and 3 barium sulphate by volume). The top of the floor shall be finished in good wood, rubber, linolium or any other non – conducting material. Protection in ceiling may be given by finishing with 25 mm thickness of cement barium mortar and painted over with white glossy paint

Place
Date

Signature of the Bidder
(NAME & ADDRESS WITH SEAL)



BHARAT HEAVY ELECTRICALS LIMITED

POWER PLANT PIPING UNIT

THIRUMAYAM- 622 507

CONTRACTS DEPARTMENT

Phone : 04333279551

E.mail : ilango@bheltry.co.in Website : www.bhel.com

Tender No:PPPU:WC:14:015

Tender Notice

Dt. 04.10.2014

- 9.1.4. Partitions – Partitions shall be built in special partition bricks moulded in the proportion of 2 clay and 1 of barium sulphate by volume and provided with a groove to accommodate reinforcement of mild steel rods. The protection afforded by these bricks against X-rays is given in the graph appended. The partitions shall be finished with cement barium plaster 15 mm to 20mm thickness laid in two coats.
- 9.1.5. Protection in doors, windows and shutters – Full protection shall always be provided for in all openings like doors, windows and shutters, etc. In the sides of door frames the lining of the barium impregnated bricks shall be done to the full thickness of the wall. Door frames shall be wrapped round with 28.2 Kg / m² (i.e., 2.5mm thick) lead sheet before being fixed in masonry. Protection in door shutters shall be given by sand weighing a 56.7 kg / m² (5.0 mm thick) sheet lead between the door proper and a covering panel of wood. Similar protection shall be given in all windows and shutters except observation windows which shall have lead glass shutters. Windows shall also be placed at a height of about 1.5 metres from floor level so that no direct radiation will pass out of the room.

EXTRACT FROM I.S. 4082

Recommendations on stacking and storage of construction

Materials at site (first revision)

3.4. Bricks :

- 3.4.1. brick shall not be dumped at site. They shall be stacked in regular tiers as and when they are unloaded to minimize breakage and defacement of bricks
- 3.4.2. In the case of brick made from clays containing the KANKAR, the bricks in stack should be thoroughly soaked in water (docked) to prevent lime bursting.
- 3.4.3. Brick stacks shall be placed close to the site of work so that least efforts is required to unload and transport the bricks again by loading on pallets or in barrows. Building bricks shall be loaded or unloaded a pair at a time unless palletized. Unloading of building bricks or handling in any other way likely to damage the corners or edges or other parts of bricks shall not be permitted.
- 3.4.4. Bricks shall be stacked on dry firm ground. For proper inspection of quality and ease in counting. The stacks shall be 50 bricks long and 10 bricks high, the bricks being placed on edge and preferably, the width of each stack shall be two bricks. Clear distance between adjacent stack shall not be less than 0.8.m
- 3.4.5. Bricks of different types and classification shall be stacked separately,.

EXTRACT FROM I.S. 1077 – 1970

Place
Date

Signature of the Bidder
(NAME & ADDRESS WITH SEAL)



BHARAT HEAVY ELECTRICALS LIMITED

POWER PLANT PIPING UNIT

THIRUMAYAM- 622 507

CONTRACTS DEPARTMENT

Phone : 04333279551

E.mail : ilango@bheltry.co.in Website : www.bhel.com

Tender No:PPPU:WC:14:015

Tender Notice

Dt. 04.10.2014

Specification for common burnt clay building Bricks

3. Classification

3.1. The common burnt clay bricks shall be classified on the basis of their minimum compressive strength. The brick of compressive strength 50 Kg / cm² shall be classified as 50.

3.1.1. Each class of bricks shall be further divided into two sub-classes . A and B based on tolerances and shape. The brick of classification 50 shall have sub-classification 50 A and 50 B.

Note : For convenience, detailed classification of bricks covered by this standard as well as in IS : 2180 (specification for heavy duty burnt clay building bricks) (First revision) has been prescribed in IS : 3102 classification of burnt clay building bricks, (First revision)

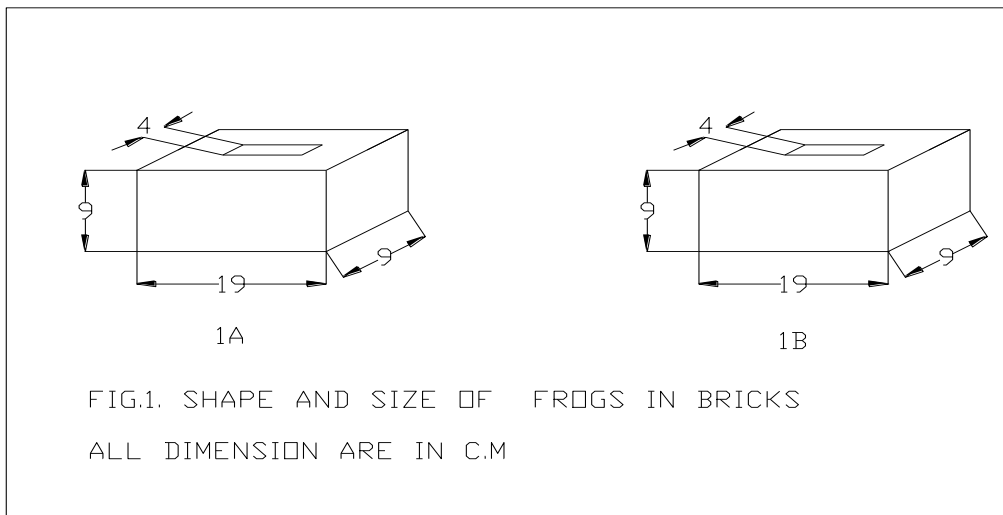

4. General Quality

4.1. Bricks shall be hand – or machine – moulded they shall be free from cracks and flaws and nodules of free lime. Brick of 9cm. Height shall be moulded with a frog 1or 2 cm. Deep on one of its flat sides; the shape and size of the frog shall conform to either fig. 1A or Fig. 1b. Bricks of 4cm. Height and those made by an extrusion process may not be provided with frogs.

4.2 The bricks of sub-class A shall smooth rectangular faces with sharp corner and emit ringing sound when struck. The bricks of sub-class B may be permitted to have slight distorted and rounded edges provided no difficulty shall arise on this account in laying of uniform courses.

5. Dimension and tolerances

5.1 The standard sizes of common building bricks shall be as follows:

Length.	Width.	Height.
Cm.	cm.	Cm.
19	9	9

Place
Date

Signature of the Bidder
(NAME &ADDRESS WITH SEAL)



BHARAT HEAVY ELECTRICALS LIMITED

POWER PLANT PIPING UNIT

THIRUMAYAM- 622 507

CONTRACTS DEPARTMENT

Phone : 04333279551

E.mail : ilango@bheltry.co.in Website : www.bhel.com

Tender No:PPPU:WC:14:015

Tender Notice

Dt. 04.10.2014

19

9

4

5.2. Tolerances- The dimension of bricks when tested in accordance with 5.2.1 shall be within the following limits:-

Sub Class A	a. Length	368 to 392 cm
	b. Width	174 to 186 cm
	c. Height	174 to 186 cm (in the case of 9cm, high bricks) 77 to 83 cm (in the case of 4 cm high bricks)
Sub Class B	a. Length	350 to 410 cm
	b. Width	165 to 195 cm
	c. Height	165 to 195 cm (in the case of 9cm, high bricks) 74 to 86 cm (in the case of 4 cm high bricks)

5.2.1. Twenty (or more according to the size of stack) whole bricks shall be selected at random from the same selected under 7. All blisters, loose particles of clay and small projects shall be removed. They shall then be arranged upon a level surface successively as indicate in Figure 2A, 2B and 2C in contact with each other and in a straight line. The overall length of the assembled bricks shall be measured with a steel tape or other suitable in extensible measure sufficiently long to measure the whole row at one stretch. Measurements by repeated application of a short rule or measure shall not be permitted. If for any reason it is found impracticable to measure bricks in one row, the sample may be divided into all the rows of 10 bricks, which shall be measured separately to the nearest millimeter. All these dimensions shall be added together.

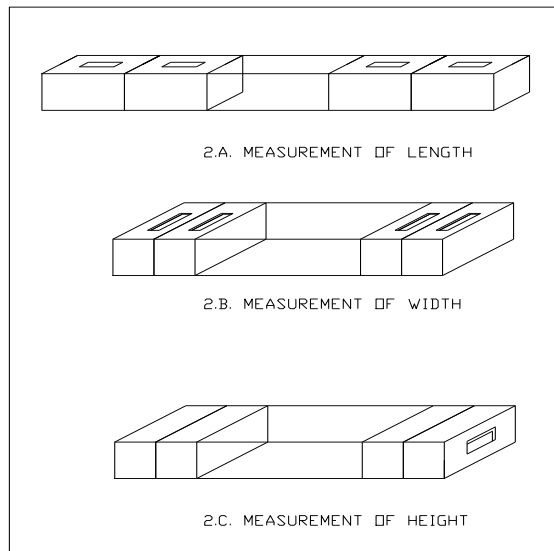

6. Physical properties

6.1. Compressive strength : Common building bricks shall have a minimum compressive strength of

Place
Date

Signature of the Bidder
(NAME & ADDRESS WITH SEAL)



BHARAT HEAVY ELECTRICALS LIMITED

POWER PLANT PIPING UNIT

THIRUMAYAM- 622 507

CONTRACTS DEPARTMENT

Phone : 04333279551

E.mail : ilango@bheltry.co.in Website : www.bhel.com

Tender No:PPPU:WC:14:015

Tender Notice

Dt. 04.10.2014

50 KG / Sq.cm . When tested in accordance with the procedure laid down in table 1 of IS : 3495 – (See not under 1-1)

6.1.1. The compressive strength of any individual brick shall no fall below the average compressive strength specified for the corresponding class of brick by more than 20 per cent.

6.2. Water absorption – When tested in accordance with the procedure laid down in table 2 of IS : 3495 (Method of sampling and testing of clay building bricks) the average water absorption of common building Bricks shall not be more than 20 per cent upto class 125 (see 3-1) and 15 per cent for higher class, by weight after immersion in cold water for 24 hours.

6.3. Efflorescent – When common building bricks are tested in accordance with the procedure laid down in Table 3 of IS : 3495 (Method of sampling and testing of clay building bricks the rating of efflorescence shall not be more than “moderate” upto Class 125 and ‘slight’ for higher classes.

EXTRACT FROM I.S. : 3012 –

Classification of burnt clay solid bricks

3.1. The classes and sub – classes of burnt clay solid bricks shall be as given in table I

TABLE – I CLASSES BURNT CLAY SOLID BRICKS AND THEIR PRINCIPAL REQUIREMENT

Type of brick	Class designation (see note below)	Compressive strength Kg / cm ² Min.	Water absorption (24 hr. Immersion percentage max,)	Efflorescence
(1)	(2)	(3)	(4)	(5)
Heavy duty (see IS:2180)	450			
	400	450	10	Nil

Common burnt clay building bricks see I.S. (1077)	350	400	10	Do
		350	15	Slight
	300	200	15	Do
	250	250	15	Do
	200	200	15	Do
	175	175	15	Do

Place
Date

Signature of the Bidder
(NAME & ADDRESS WITH SEAL)



BHARAT HEAVY ELECTRICALS LIMITED

POWER PLANT PIPING UNIT

THIRUMAYAM- 622 507

CONTRACTS DEPARTMENT

Phone : 04333279551

E.mail : ilango@bheltry.co.in Website : www.bhel.com

Tender No:PPPU:WC:14:015

Tender Notice

Dt. 04.10.2014

	150	150	15	Do
	125	125	20	Moderate
	100	100	20	Do
	75	75	20	Do
	50	50	20	Do

NOTE : Each class of bricks shall further be divided into sub Classes A, B etc., based on the following :

Sub – Class A – Tolerance limit shall be ± 3 per cent and shall have smooth rectangular faces with sharp corners and emit clear ringing sound.

Sub – class B – Tolerance limit shall be ± 8 percent and shall be permitted to have slight distortion and rounded edges, provided no difficulty shall arise in laying of uniform courses.

Specification for burnt clay facing bricks (First Revision)

3. Classification

3.1. The facing bricks shall be of two classes

- (a) Class I ; and
- (b) Class II

4. General Quality :

4.1. The facing bricks shall be made of clay, shale or mixture of these materials with or without admixtures and burnt to meet the requirements of this standard. The colouring material added to the clay shall be suitable ceramic materials and shall be well distributed throughout the body. The brick shall be of uniform colour.

4.2. The bricks shall be free from cracks, flaws and modules of free lime and of even texture. These shall be thoroughly burnt and shall have plane rectangular faces with parallel sides and sharp straight right angled edges.

5. Dimensions and tolerances

5.1. The standard sizes of the facing bricks shall be 19X9X9 cm. And 19X9X4 cm

5.2. The permissible tolerances shall as under :

Dimension	Tolerance	
	Class I	Class II
Cm	mm	mm
19	± 3	± 5
9	± 2	± 3
4	± 1.5	± 2

Place
Date

Signature of the Bidder
(NAME & ADDRESS WITH SEAL)



BHARAT HEAVY ELECTRICALS LIMITED

POWER PLANT PIPING UNIT

THIRUMAYAM- 622 507

CONTRACTS DEPARTMENT

Phone : 04333279551

E.mail : ilango@bheltry.co.in Website : www.bhel.com

Tender No:PPPU:WC:14:015

Tender Notice

Dt. 04.10.2014

6. Physical requirements

- 6.1. The average compressive strength obtained in accordance with the procedure laid down in Table I of IS : 3495 (Method of sampling and testing clay building bricks) shall not be less than 50 Kg / cm² for 50 Class designation bricks, 75 Kg / cm² for class II and 100 kg / cm² for Class I
- 6.2. The water absorption requirement when tested in accordance with the procedure laid down in Table 2 of IS : 3495 for 24 h immersion shall not exceed 15 per cent.
- 6.3. when tested in accordance with the method specified in Table 3 of IS : 3495 efflorescence requirements shall be 'Nil' for both classes.
- 6.4. When measured in accordance with the method specified in Table 4 of IS : 3495 the warpage for both classes shall not exceed 2-5 mm.

EXTRACT OF IS : 2212

Code of Practice for Brick Work

Nominal thickness of a wall – This is the thickness of wall that is stated in the estimates for calculation of quantities. It is a 'fictitious' dimension, which is neither the actual thickness of wall excluding surfaces finishes like plaster, rendering, etc., nor necessarily the overall thickness including such finishes. The following example will illustrate this point :-

	Nominal Thickness	Actual thickness
For traditional brick of 9 in length (with allowance of ¼ in. for mortar joint)		
One brick wall	9in	8 ½ to 8 ¾ in
1 ½ brick wall	13 ½ in	13 to 13 ¼ in.
2 brick wall	18 in	17 ½ to 17 ¾

For modular brick (with allowance of 1 cm. For mortar joint)		
One brick wall	20 cm	19 cm
1 ½ Brick wall	30 cm	29 cm
2 Brick wall	40 cm	39 cm

- 4.1.1 Bricks – Unless otherwise specified, burnt – clay bricks shall conform to the requirements of IS :1077 specification for common burnt clay building bricks, and shall be of the specified class.
- 4.1.2 Mortars – Mortars for masonry shall be prepared in accordance with IS : 2250 Code of Practice or preparation and use of masonry mortars.
The materials used for mortar shall conform to the requirements specified 4-2-1 to 4-2-4.
- 4.1.3 Cement – Cement used for brick masonry shall be ordinary or rapid – hardening Portland cement conforming to IS : 269 Specification for ordinary, Rapid – hardening and Low Heat Portland Cement (Revised) or blast furnace slag cement conforming to IS : 455, Specification for port land Blast – furnace slag Cement (Revised)

Place
Date

Signature of the Bidder
(NAME & ADDRESS WITH SEAL)



BHARAT HEAVY ELECTRICALS LIMITED

POWER PLANT PIPING UNIT

THIRUMAYAM- 622 507

CONTRACTS DEPARTMENT

Phone : 04333279551

E.mail : ilango@bheltry.co.in Website : www.bhel.com

Tender No:PPPU:WC:14:015

Tender Notice

Dt. 04.10.2014

- 4.1.4 Lime – Lime used for brick masonry shall conform to the requirements of IS 712, Specification for Building Limes. This may be used in the form of either hydrated lime or lime putty. Field slaking of lime shall be done in accordance with IS : 1635 Code of Practice for Field slaking of lime and preparation of Putty.
- 4.1.5 Fine aggregate – Sand shall conform to IS : 2116 Specification for sand for masonry Mortar.
- 4.1.6 Water – Water used for masonry mortar shall be clean and free from injurious amounts of deleterious materials.

5. Design Consideration

5.1. Selection of bricks

- 5.1.2. For use in various situations of brick masonry, the brick shall be selected in accordance with Table - I
- 5.1.3. When the requirements for strength of masonry predominate in the particular situation of use, the bricks shall be of such grade (see IS: 1077) as to give the required strength for masonry and shall be selected in accordance with their relevant provisions of IS : 1905 – Code of Practice for Structural Safety of buildings Masonry Walls.

5.2. Selection of mortars :

- 5.2.1. Mortars used for Brick Masonry shall conform generally to IS : 2250 – Code of Practice for Preparation and use of Masonry Mortars.

TABLE I : SELECTION OF BUILDING BRICKS

(Clause 5-1.1)

Serial number and situation of use	Type of brick to be used	Special consideration	Remarks
1. Facing	Class I Common bricks (SEE IS : 1077)	Bricks shall be free from minor defects such as chips at the edge of corners. Colour and texture may also be specified. If so required	...
2.a. Subject to very heavy loading	Heavy duty (See IS : 2180)
b. Requiring a high resistance to water penetration	Do
3. (a) Plinths and foundations below damp-proof course ground well drained and no chance of continual wetting in foundations	Class I or Class II common bricks (See IS : 107)
b) Plinths and foundations below damp – proof course subsoil water table at a high	Do	The bricks shall be free from efflorescence. These shall also not have any salt content which will affect the mortar of the	

Place
Date

Signature of the Bidder
(NAME & ADDRESS WITH SEAL)



BHARAT HEAVY ELECTRICALS LIMITED

POWER PLANT PIPING UNIT

THIRUMAYAM- 622 507

CONTRACTS DEPARTMENT

Phone : 04333279551

E.mail : ilango@bheltry.co.in Website : www.bhel.com

Tender No:PPPU:WC:14:015

Tender Notice

Dt. 04.10.2014

level		masonry. The bricks may preferably be the densest available with the minimum water absorption	
-------	--	---	--

SECTION VI STONE MASONRY

I.S. Number	INDIAN STANDARDS EXTRACTS
1127	Recommendations for dimensions and workmanship of natural building stones for masonry works
2250	Code of practice for preparation and use of masonry mortars
1597	Code of practice for construction of stone masonry – Part I rubble stone masonry
1597	Part II – Ashlar masonry
4515	Code of practice for boulder lining for canals
1200	Part IV – Method of measurement of building and civil engineering works – Stone masonry
1123	Method for petrographical examination of natural building stones
C.B.R.I.	Pre cast stone masonry block walling – Data Sheet No.8
6042	Code of practice for construction of light weight concrete block masonry

SECTION VI STONE MASONRY

SPECIFICATION NO. 35 STONE MASONRY

1. General – The following instructions are to be complied with for all classes for stone masonry
 - 1.1. Requirements for building stone – Building stones shall comply with specification No.3 and shall be obtained from the quarries defined in the agreement descriptive specification sheet – for detailed specification of stones I.S. 1597 Part 1 and I.S. 1123 shall apply. Stone not suited for the particular class of works defined in the schedule items shall be rejected and rejected stone shall be removed once by the contractor from the works spot vide “General Conditions of contract”.
2. Method of laying stone – Lay on broadest face which gives better opportunity to fill the spaces between stones. For detailed specification I.S. 1597 Part I shall apply.
3. Bond – For detailed instructions I.S. 1597 Part I 1967 shall apply.
4. Watering – For detailed instruction I.S. 1597 Part I shall apply.

Place
Date

Signature of the Bidder
(NAME & ADDRESS WITH SEAL)



BHARAT HEAVY ELECTRICALS LIMITED

POWER PLANT PIPING UNIT

THIRUMAYAM- 622 507

CONTRACTS DEPARTMENT

Phone : 04333279551

E.mail : ilango@bheltry.co.in Website : www.bhel.com

Tender No:PPPU:WC:14:015

Tender Notice

Dt. 04.10.2014

- 4.1. Mortar – Should be mortar perish i.e., become dry, white or powderly through neglect of watering, the work shall be pulled down and rebuilt at the contractor's expense or should the contractor fail to water the work to the satisfaction of the officer in charge of the work, the latter may supply the requisites men to water the work properly and charge the cost to the contractor.
- 4.2. All masonry shall be washed down on completion and all stains – lime or otherwise – removed from the face
5. Moving stone after it has been placed upon the mortar bed. –
- 5.1. If it is necessary to move stone after it has been placed on the mortar bed, it should be lifted clear and be reset. Attempt must never be made to slide it over stone already laid. Care must be taken not to disturb joints already laid when handling or moving stone.
6. Bed Plates – Bed plates are to be laid in all cases under the ends of beams, girders, roof trusses, etc. The bed plates are to be of sizes specified or ordered by the Executive Engineer. In all important cases cut stone or reinforced concrete blocks will be used and the size quantity detailed and included under the relevant item of work. In all other cases where cut stone or reinforced concrete bed plates are not demanded, the contractor shall supply large stone of size and dressing as ordered by the Executing Engineer and he will not be paid any extra rate above the contract rate for the wall masonry for such bed plates.
7. Recesses for ends of beams, girders, etc., corbels under heavy beams and cornice under joists- The ends of all beams, girders, roof trusses, etc., shall be situated in a recess having 40mm. space around them to permit free circulation of air and provided with perforated zinc sheeting
- 7.1. Joists and rafters will usually be built in the masonry and tarred for that portion. When it is approved by the Executing Engineer to build the ends of steel joists or other steel work into masonry the masonry for atleast 15 cm. Around the embedded steel shall be in cement mortar. No extra payment will be made for this treatment.
8. Stones which are not to be plastered over – All lintels and inside stones which are not to be plastered over should be to the full width of the walls in which they are placed including the thickness of the plaster.
9. Plinth off-sets on the interior faces only should be kept 15cm. below flood level (unless finished thickness of the floor to be laid, will determine, instead of the 15cm.), to allow the floor paving, which is done subsequently, coming up to the face of the superstructure. Similarly retaining walls of verandahs, etc. must be built with due regard to the slope allowed for the floors.
10. Jambs for door and window openings.- Jambs for door and window openings shall be formed with quoins of the full height of the course in the case of coursed masonry. The quoins shall be in breadth atleast one and a half times the depth of the course and in length at least twice the depth. For each side of door openings three and for window openings two, of these quoins shall be stones of the full thickness of the walls. Unless rebating of the whole frame into the

Place
Date

Signature of the Bidder
(NAME & ADDRESS WITH SEAL)



BHARAT HEAVY ELECTRICALS LIMITED

POWER PLANT PIPING UNIT

THIRUMAYAM- 622 507

CONTRACTS DEPARTMENT

Phone : 04333279551

E.mail : ilango@bheltry.co.in Website : www.bhel.com

Tender No:PPPU:WC:14:015

Tender Notice

Dt. 04.10.2014

masonry is specially specified, chisel dressing to the width of door and window frames shall be done to secure a close fit between the frame shall be done to secure a close fit between the frame and the masonry. A rebate shall be made in the frame where plastering is to join with the frame as shown in the standard designs for doors and windows and the plaster shall be keyed well into the rebate to form a neat joint. Jambs shall be played as described in the standard specification for "Brick Masonry – General". Contract rates for all classes of masonry are inclusive of quoins, jambs, and chisel dressing as demanded by the above and by the following masonry sub specifications.

11. Contractor to supply sample stones when tendering his rates – In the case of cut stone masonry or rubble masonry of any kind, the contractor shall supply a sample stone when tendering his rates, showing the class of dressing and face finish that he will execute for each rate and these sample stones will be initialed and kept by the Executive Engineer. Failure of the contractor to execute all work of the particular clause up to the standard of his sample supplied, will be dealt with as contractor's violation of the contract
12. Mortar and materials to conform to standard specification : - The mortar to be used for each class of masonry shall conform to the particular standard specification for that class or mortar and the standard specifications for the materials used therein. For example, for "Cut stone in cement mortar" the Portland cement, sand and cement mortar shall conform to the three respective standard specification for these items.
13. Dowels and cramps – When so specified or instructed by the Executive Engineer, copings will be dowelled or cramped – and courses of pillars, skew-backs and similar work joggled to the stone below it using dowels and cramps of the hardest and toughest stone procurable or of copper and set in pure lime or cement as ordered Iron cramps are not to be used. Extra payment for such dowels or cramps will be fixed by prior agreement before execution of the work.
14. Holes for passage of water, etc., to be left and wooden plugs and wooden bricks to be built in during construction – Care shall be taken to see that holes for passage of water wherever necessary as from terraces, bath rooms, recesses for downfall pipes, etc. are provided during construction and neatly finished off by pointing or plastering as ordered. Well – seasoned wooden plugs and bricks of sizes and quality approved by the Executing Engineer are to be built in as the work proceeds for fixing door and window shutter appliances coat hangers, picture rails, and for any other purpose decided necessary by the Executing Engineer are to be built in as the work proceeds for fixing door and window shutter appliances coat hangers, picture rails, and for any other purpose decided necessary by the Executive Engineer. Holes are also to be cut in the sill stones to receive the uprights of door – frames, in cases where there is no threshold plate to the frame. No extra payment will be made to the contractor for the supply and fixing of the wooden plugs and bricks forming holes, etc. as described in this clause, for any class masonry vide also relevant clauses in the Standard "Preliminary specification".
15. Laterite : - In districts where laterite is used as a building stone, the work shall be executed according to the relevant masonry sub specification which will be described in the schedule

Place
Date

Signature of the Bidder
(NAME & ADDRESS WITH SEAL)



BHARAT HEAVY ELECTRICALS LIMITED

POWER PLANT PIPING UNIT

THIRUMAYAM- 622 507

CONTRACTS DEPARTMENT

Phone : 04333279551

E.mail : ilango@bheltry.co.in Website : www.bhel.com

Tender No:PPPU:WC:14:015

Tender Notice

Dt. 04.10.2014

item. The stone shall be the best procurable and free from any admixture of the white earth. It shall be dug out from the quarry a sufficient time in advance, to harden well, before being placed in the work. The least thickness of stone shall be 17-5 cm and other dimensions shall be as laid down in the relevant sub-specification , the stones being laid header and stretcher alternatively, breaking joints by atleast 7.5. cm

16. Iron, stone, concrete or other fixtures and buttresses etc., - All iron, stone, , concrete or other fixtures, returns buttresses, counter forts, etc., shall be built and bonded into the work as it proceeds and not inserted or joggled on after the masonry is advanced. No extra payment will be made for labour involved in building in any fixtures, holdfasts etc., which are given to the contractor for fixing in place.
17. Wet foundation – In wet foundations, the excavation shall be kept free of water by the contractor, while the masonry is in progress and until the Executing Engineer considers the mortar has sufficiently set.
18. Scaffolding and tools and plant – Vide relevant clauses under the conditions of contract
19. Chisel drafting corners and rounding interior corners of room – The Vertical exterior corners of buildings and pillars of buildings in coursed rubble in mortar, first and second sort and random rubble in mortar (except for clay mortar masonry) shall be chisel drafted 40mm. width on either side, or such other width as may be specified. AT the entrance of doors, windows, archways and other openings, the corners against which doors and windows will open shall be chamfered 25 mm. width and chisel-drafted beyond the chamfer 40mm. as above (when parliamentary hinges are used chisel drafting only is necessary)
 - 19.1. All interior corners of rooms and projecting angles shall be rounded to 25 mm radius. The projecting angle will in such cases be chamfered as necessary and the rounding for both interior corners and projecting angles will then be done in the plaster, Similarly rounded, chamfered and chisel drafted corners shall be done wherever else they may be shown on the drawings
 - 19.2. All chisel drafting and chamfering referred to under this clause shall be included by the contractor in the tender unit rate for masonry and rounding of corners in his tender unit rate for plastering. No extra allowance will be made for labour and materials involved in compliance with this clause, unless it is so expressly stated in the agreement specification.
 - 19.3. Sketches illustrative of the nature of work to be done under this clause and clause 10 preceding are appended.
20. Pointing : Clause 10 of the standard specification for “Brick Masonry” “General” shall apply to this specification.
21. Anti-termite constructional methods :- At places of foundation where the existence of colonies of subterranean termites are found the probability of internal attack of termites through floors and plinth fitting is great. In such places the constructional practices for protection against subterranean termites originating both internally from within the plinth and externally from the area surrounding the building as laid down in IS 6313(Part-I) shall be followed.

Place
Date

Signature of the Bidder
(NAME & ADDRESS WITH SEAL)



BHARAT HEAVY ELECTRICALS LIMITED

POWER PLANT PIPING UNIT

THIRUMAYAM- 622 507

CONTRACTS DEPARTMENT

Phone : 04333279551

E.mail : ilango@bheltry.co.in Website : www.bhel.com

Tender No:PPPU:WC:14:015

Tender Notice

Dt. 04.10.2014

22. This general specification applicable to sub-specifications : The clauses of this "General" Specification shall be applicable in all pertinent points to the masonry sub-specifications followings and the contract unit rate for each particular item of work is inclusive of compliance with all clauses of the "General" specification and relevant sub-specifications.

Place
Date

Signature of the Bidder
(NAME & ADDRESS WITH SEAL)



BHARAT HEAVY ELECTRICALS LIMITED

POWER PLANT PIPING UNIT

THIRUMAYAM- 622 507

CONTRACTS DEPARTMENT

Phone : 04333279551

E.mail : ilango@bheltry.co.in Website : www.bhel.com

Tender No:PPPU:WC:14:015

Tender Notice

Dt. 04.10.2014

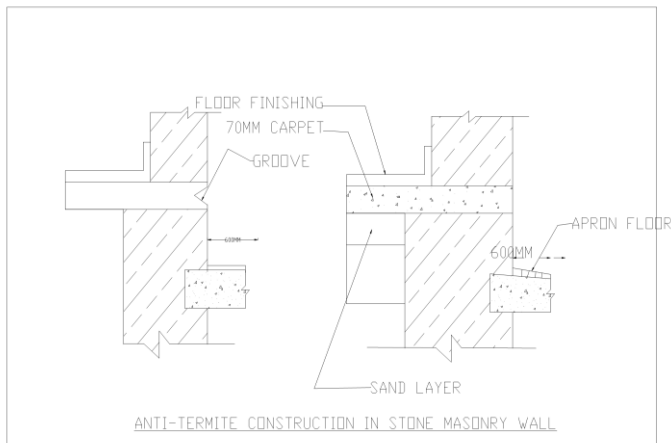
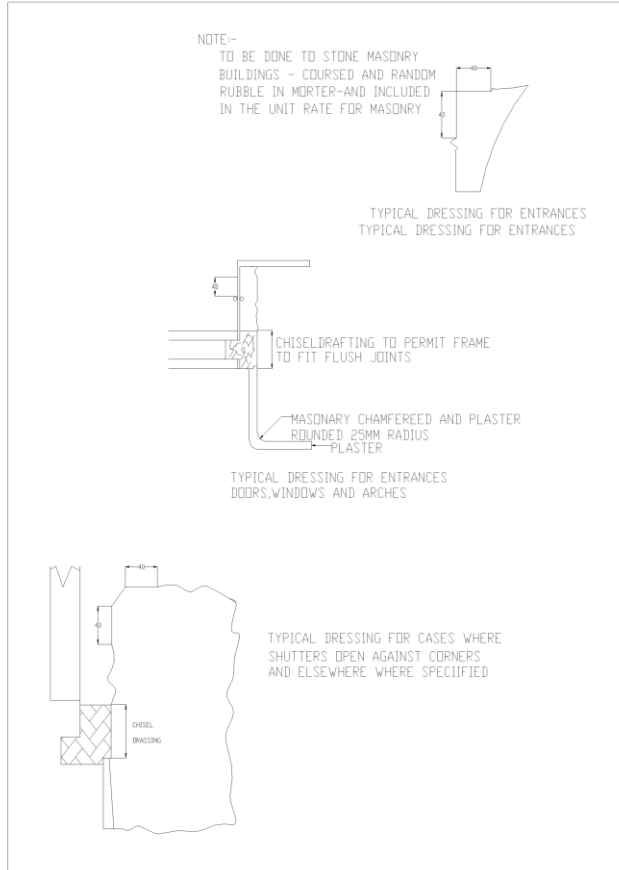

Place
Date

Signature of the Bidder
(NAME & ADDRESS WITH SEAL)



BHARAT HEAVY ELECTRICALS LIMITED

POWER PLANT PIPING UNIT

THIRUMAYAM- 622 507

CONTRACTS DEPARTMENT

Phone : 04333279551

E.mail : ilango@bheltry.co.in Website : www.bhel.com

Tender No:PPPU:WC:14:015

Tender Notice

Dt. 04.10.2014

SPECIFICATION NO. 35 – A

CUT STONE IN MORTAR

Additional clauses to “General” preceding

Cut stone : I.S. 1597 Part II 1967 para 6.1.1. shall apply. By fine tooled dressing or fine dressing is meant the finest surface which can be given to a stone with a chisel and without rubbing.

- 1.1. In the absence of further definition cut stone masonry shall be executed with a fine dressing for the face vide the accompanying figures.
- 1.2. Masonry shall be laid as per I.S. 1597 Part II – 1967 and I.S. 1127 – 1970.
- 1.3. In walls 75 cm thick and under the headers shall run right through the wall.
2. Fixing measurement and payment for certain features instructions in I.S. 1200 Part iv – 1970 shall apply.
3. All fine dressed cut stone work shall be protected by means wood boxing immediately after fixing at the contractors expense.

SPECIFICATION NO. 35 – B

CUT STON IN SURKI MORTAR

1. The specification shall be the same as specification No. 35 – A. The mortar shall be as per I.S. 2250 – 1965.

SPECIFICATION NO. 35 C,

CUT STONE STRING COURSE BOND AND OTHER CORNICES ETC. IN MORTAR

SPECIFICATION NO. 35-D

ASHLAR ARCHING

Additional clauses to “General” preceding

1. The arch stones shall be closely of the same size and carefully and accurately wrought, giving the proper radiating joints, that is the arch stones shall be dressed full and true to their proper shapes and shall be carefully set in good fine mortar. Thickness of ring and class of mortar will be defined in the relevant schedule item.
 - 1.1. The arch stones shall not be less than 25 cm on their least dimension and header joints shall break joint atleast 22.5 cm. In arches upto 60 cm in thickness, the stones shall all be of the full thickness of ring. For deeper arch rings, the Executing Engineer will supply instructions regarding bond, face stones and key stones.
 - 1.2. Exact uniformity will be required in the thickness of the arch ring, and in oblique or skew arches, great care is to be taken to dress the beds to the required winding.

Place
Date

Signature of the Bidder
(NAME & ADDRESS WITH SEAL)



BHARAT HEAVY ELECTRICALS LIMITED

POWER PLANT PIPING UNIT

THIRUMAYAM- 622 507

CONTRACTS DEPARTMENT

Phone : 04333279551

E.mail : ilango@bheltry.co.in Website : www.bhel.com

Tender No:PPPU:WC:14:015

Tender Notice

Dt. 04.10.2014

- 1.3. All arch work stones should be of special large stones. The breadth of each stone at top and bottom will be determined at the time of execution according to the span and number of stones.
2. Dressing : The header and side radial joints shall be fine tooled to exact fit on all beds ; the keying course shall be accurately fitted in and driven into its place with heavy wooden beaters.
 - 2.1. The side or radial joints shall be perpendicular to the tangent of the curve of the arch at each point and a right angles to the face. The soffit shall be dressed to the true curve of the arch and the back or upper surface of the arch stone shall be dressed to the true curve ofextrados or each stone shall have it supper surface dressed to a plane flat surface according as the drawing may indicate. The thickness of each joint shall not exceed 3 mm.

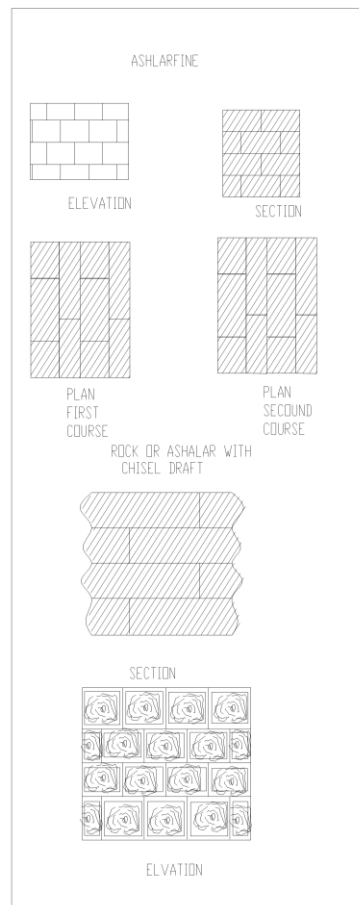

Place
Date

Signature of the Bidder
(NAME & ADDRESS WITH SEAL)



BHARAT HEAVY ELECTRICALS LIMITED

POWER PLANT PIPING UNIT

THIRUMAYAM- 622 507

CONTRACTS DEPARTMENT

Phone : 04333279551

E.mail : ilango@bheltry.co.in Website : www.bhel.com

Tender No:PPPU:WC:14:015

Tender Notice

Dt. 04.10.2014

3. **Face stones** : The face stones shall be fine tooled, or rock faced as specified or shown on the drawings. It will also be separately as specified if chamfering is to be done to the exposed radial joints of face stones and horizontal joints of the soffit.
4. **Centres** : - The contractor shall furnish for the approval of the Executive Engineer, plans for the centers of all arches up to 4.5 m. span. For larger span arches, the Executing Engineer will prepare centering plans and furnish the same to the contractor, except in the case of lump sum contracts, where the contractor shall prepare and submit the plans of the centers proposed to be used for prior approval by the Executive Engineer. For spans larger than 1.8 m timber centers are to be used and are to be provided with hardwood wedges for slackening, the centers sand boxes shall be used for slackening for spans over 6m. In all centers, the arrangement shall be such that the slackening can be effected without any vibration being transmitted to the arch and in the case of a series of arches that the centers can all be slackened simultaneously. If the centers are not of clear span, butt rest on intermediate brick pillars, the brick pillars, shall be well and strongly built, the top of each pillar being capped with wood and connected up with other pillars by a continuous piece of timber from abutment or abutment.
 - 4.1. In all centers, the upper bearing surface shall be very correctly formed to the curve of the intrados of the arch.
 - 4.2. The contractor shall obtain instructions from the Executive Engineer, regarding the number of hours after completion of the arch that the centers shall be sufficiently slackened to compress the joints (re-tightening at once) and also the time for complete removal. When using a lime mortar centers will ordinarily be slackened within 24 hours after completion of the arch. Care shall be taken however that the centers are not slackened while the mortar in the last finished joints is still so soft that it will be squeezed out, but at the same time, the centers shall be slackened while the mortar is still moist, so as to allow the arch to compress itself and bring all the joints to fair bearing. In the case of a segmental arch care shall be taken to see that the skew backs are secure (they are better to be given a week's time to set and in the case of semi O- circular, elliptical, pointed or other arches springing from a horizontal joint, that the adjacent wall has been built up to two thirds of the height of the arch, before slackening centers. With a quick - setting cement mortar, centers should be left will the mortar has finally set.
 - 4.3. During the progress of the work, care must be taken to distribute the load on the centers in order to obtain a true curve at the completion of the work. Before turning arches exceeding 12m. span the middle half of the center shall be loaded with all the material which is to be used on that portion of the arch ring.
 - 4.4. The rate for arch work is to include the provision of proper centers as described above – together with sand boxes setting up easing and removing the same irrespective of the size of the arch. (centers or sand boxes are to be supplied by the department to the contractor, then such will be entered in the tender notice and the rates shall be tendered accordingly)

Place
Date

Signature of the Bidder
(NAME & ADDRESS WITH SEAL)



BHARAT HEAVY ELECTRICALS LIMITED

POWER PLANT PIPING UNIT

THIRUMAYAM- 622 507

CONTRACTS DEPARTMENT

Phone : 04333279551

E.mail : ilango@bheltry.co.in Website : www.bhel.com

Tender No:PPPU:WC:14:015

Tender Notice

Dt. 04.10.2014

5. Removal of bad work – If any arch settles unduly or becomes unsightly through carelessness, bad workmanship, centering or bad material, it shall be removed or re-built at the contractor's expense.
6. Measurement – Measurement of arch work shall be the mean of the lengths of extrudes, the full breadth of the arch and the full thickness of the ring.

SPECIFICATION NO. 35-E

RUBBLE ARCHING

Additional clauses to "General" proceeding

1. Rubble arching shall consist of flat bedded slabs laid solidly and flush in mortar with their radial joints perpendicular to the tangent to the curve of the arch at each point and the arch stone shall properly break joint a heading joints. The mortar to be used shall be standard specification mortar of the class described in the Schedule item wording and the thickness of arch ring will be defined therein. Each slab shall be hammer dressed approximately to the proper shape, with the necessary summering so that the arch stone may bear fairly one upon another for the full thickness of the arch ring, and should parts for the full thickness of their arch ring, and should parts of the backs of the stones be open they shall be solidly wedged up with spalls and chips of stones set in mortar. The exposed faces of the face or quoin stone shall be bushed or plain dressed as specified with face perpendicular to the length inwards. The soffit shall be dressed to a plane surface, true at all points to the curve of the arch.
2. The joints on face and soffit shall not exceed 12mm. in thickness.
3. The arch quoins shall be of the same thickness as the sheeting of the course, but they shall be superior selected stones, in all cases extending right through from intrados to extrados and alternately not less than 37.5 cm and 5.3 cm long perpendicular to the face of the arch.
4. Interior arch stone in the sheeting shall not be less than 75 mm in least dimension, and the stones shall break joint with each other 150mm. In arch rings 37.5 cm. thick and under, all stones shall be of full thickness of the ring.
5. In arch rings more than 37.5 cm thick, the stones will be laid in alternate courses of headers and stretchers, unless otherwise specify. Not more than two stones going to make up the thickness of the arch ring.

SPECIFICATION NO. 35 F

RUBBLE IN MORTAR (FIRST SORT)

1. I.S. 1597 / Part I shall apply

Place
Date

Signature of the Bidder
(NAME & ADDRESS WITH SEAL)



BHARAT HEAVY ELECTRICALS LIMITED

POWER PLANT PIPING UNIT

THIRUMAYAM- 622 507

CONTRACTS DEPARTMENT

Phone : 04333279551

E.mail : ilango@bheltry.co.in Website : www.bhel.com

Tender No:PPPU:WC:14:015

Tender Notice

Dt. 04.10.2014

- 1.1. The stones shall be solidly bedded set full in mortar with joints not exceeding 12mm thickness and with no pinning whatever on the face and shall extend well back into the hearting
- 1.2. In all walls upto a width 60 cms. Bond stones running through the wall shall be provided of intervals of 1.8 metres clear in every course. For walls thicker than 1.8 metres a line of headers each header overlapping the other by 30 cms. Or more shall be provided from front to back at 1.8 metres interval in every course. Care shall be taken not to place the bond stones of successive course over each other. The position of bond stones shall be marked on both the faces for identification and verification (Tar marking where plaster is to be applied will suffice)
2. under-pinning of any description to be allowed and hollow bedding and flushing such gaps with mortar are to be carefully avoided.
3. The work on the interior face shall be precisely the same as on the exterior face unless the work is to be plastered, in which case the side joints need not be vertical.
4. The rate per cubic metre shall be for finished work inclusive of all dressing, chisel drafting etc. The contractor shall therefore tender his rate to cover the dressing required to comply with the specification.

SPECIFICATION NO. 35 – G

RUBBLE IN MORTAR (SECOND SORT)

1. I.S. 1597 Part – I and I.S. 127 shall apply

- 1.1. The whole width of the wall will be paid for as coursed rubble in mortar second sort unless it is specified that a certain thickness will be paid for as coursed rubble and the balance as random rubble

N.B. In thick walls such as lock walls, etc., the Executing Engineer will determine and specify in the tender notice the width which will be paid for under each class of work.

SPECIFICATION NO. 35 H

RANDOM RUBBLE IN MORTAR

1. For details of random rubble work I.S. 1127 and I.S. 1597 Part I shall apply.
2. No pinning whatever shall be used on the face "Bushings" shall not project beyond the face of the wall more than 12mm. in the faces proposed to be plastered.
3. Measurement of stone masonry is covered by I.S. 1200 Part IV shall apply.

SPECIFICATION No. 35 – I

RANDOM RUBBLE IN CLAY

1. the mud to be used for mortar shall be prepared from carefully selected earth of tenacious nature to which sand shall be added in such quantity that a dried lump of mixture shall not show signs of cracking. The mud shall be well trodden and worked into the consistency of a thick paste by the addition of sufficient water. The mixture thus made shall be kept for a week allowing water to stand on the top of the mud in a shallow pool. The mud thus stored

Place
Date

Signature of the Bidder
(NAME & ADDRESS WITH SEAL)



BHARAT HEAVY ELECTRICALS LIMITED

POWER PLANT PIPING UNIT

THIRUMAYAM- 622 507

CONTRACTS DEPARTMENT

Phone : 04333279551

E.mail : ilango@bheltry.co.in Website : www.bhel.com

Tender No:PPPU:WC:14:015

Tender Notice

Dt. 04.10.2014

up shall be well tamped with water by treading when it is to be used on the work, care being taken to remove all clods and stones.

2. The work shall be executed to the same specification as the standard specification for random rubble in mortar with the exception the clay of the above description is to be used instead of mortar.

N.B. It is customary with this class of masonry in building to executive top 30 cm. of walls and 30 cm. around doors and windows with random

SPECIFICATION NO. 35 – J

PRECAST STONE MASONRY BLOCK WALLING

- 1.1. The concrete used for moulding the pre cast stone block shall be as specified in Specification No.28.
- 1.2. The stones shall be of such variety conforming to the requirements of building stones as laid down in Specification No.35.
- 1.3. The method of production, dimensions of blocks and moulds, casting or blocks shall be done as specified in Data Sheet No.8 of C.B.R.I. Roorkee.
- 1.4. The average compressive strength for various mix proportions shall be as in Table 2 of Data sheet mentioned above
- 1.5. The blocks shall be used for load bearing and non – load bearing walls. The permissible stresses in the masonry shall be taken from I.S. Code 1905 – 69 “Structural Safety of Buildings Masonry Walls “ depending upon the mortar to be used for laying and compressive strength of the blocks. Masonry bonds construction and curing shall be as laid down in the Data Sheet mentioned above.
- 1.6. The data furnished by C.B.R.I. Roorkee shall be followed for guidance only.

SPECIFICATION No.35 – K

CONCRETE BLOCK MASONRY

1. Clerical Blocks

- 1.1. Materials – The concrete is a light weight material of uniform porous structure obtained as a result of aerating the green concrete mix with gas. The main ingredients shall be sand quick lime, cement, fly ash aluminium powder and gypsum.

- 1.2. Properties of concrete shall be as given under.

1. Density (dry)	2,750 Kg / m ³
2. Specific gravity	0.75
3. Crushing Stress	50 to 60 Kg. / cm ³
4 Tensile stress	4 Kg / cm ²

Place
Date

Signature of the Bidder
(NAME & ADDRESS WITH SEAL)



BHARAT HEAVY ELECTRICALS LIMITED

POWER PLANT PIPING UNIT

THIRUMAYAM- 622 507

CONTRACTS DEPARTMENT

Phone : 04333279551

E.mail : ilango@bheltry.co.in Website : www.bhel.com

Tender No:PPPU:WC:14:015

Tender Notice

Dt. 04.10.2014

5. Shear stress	7.5 Kg / cm ³
6. Bond Stress	4 Kg / cm ²
7. Modulus of elasticity	1.96 to 2.25 X 10 ⁴ Kg. / cm ²
8. Absorption test	Not exceeding 45 per cent to volume in 48 Hours
9. Capillary action	3 cm in 24 hours
10. Shrinkage	0.30 mm / m.for variation of 80 per cent humidity
11. Thermal conductivity	0.155 K cal/sq.mh. (degree c/m)
12. Fire resisting	Good

1.3. Block sizes and finish.- The sizes of blocks used shall be as follows:-

- For load bearing walls (1) 59 cm X 24 cm X 19 cm
(2) 59 cm X 15 cm X 19 cm
For Partition walls (1) 59 cm X 12 cm X 19 cm
(2) 59 cm X 10 cm X 19 cm

Maximum variation in dimensions shall not be more than \pm mm for height and breadth and \pm 3mm. for length. The faces of the blocks shall be rectangular opposite faces shall be parallel and all arises shall be square and straight. The angles of the blocks shall be right angles and the edges shall be sharp unless otherwise specified.

Allowable compressive and tensile stress – The maximum compressive stress shall be 50 to 60 Kg / cm² . The tensile stress shall be 10 to 14 per cent of the allowance compressive stress.

1.4. Stacking and handling – Celcrete blocks shall be stock – piled on planks or other supports free from contact with the ground. The blocks shall be handled with care and damaged units shall be rejected.

2. Celcrete masonry :

2.1. Mortar – Cement mortar 1:6 (one cement and six sand shall be used. For detailed specifications for cement mortar I.S. : 2250 shall apply

2.2. Strength and stability – Minimum thickness of load bearing walls shall be 15 cm. and minimum nominal thickness of non – load bearing partition wall shall be 10cm. thick

Celcrete masonry shall be designed in accordance with I.S. : 1905 .

Place
Date

Signature of the Bidder
(NAME & ADDRESS WITH SEAL)



BHARAT HEAVY ELECTRICALS LIMITED

POWER PLANT PIPING UNIT

THIRUMAYAM- 622 507

CONTRACTS DEPARTMENT

Phone : 04333279551

E.mail : ilango@bheltry.co.in Website : www.bhel.com

Tender No:PPPU:WC:14:015

Tender Notice

Dt. 04.10.2014

- 2.3. Laying – Laying of concrete block masonry in superstructure shall be as in paragraph 10 of I.S. : 6049 (code of practice for construction of light weight concrete block masonry) (extract furnished)
- 2.4. Finishing – External plastering shall be done if so specified. The specification No. 56 shall apply for plastering with cement mortar.
- 2.5. Concrete masonry shall be constructed for superstructure only and shall not be used in foundation.

SPECIFICATION NO. 39 F

LAYING INSITU CEMENT CONCRETE FLOORING WITH FLOOR TOPPING

1. I.S. 2371 and 5491 shall apply

For granolithic concrete floor topping the mix proportion given in I.S. 5491 shall be adopted and as regards specifications on size of panel laying floor topping etc. the same specifications as given in I.S. 2571 for cement concrete flooring shall be followed.

NOTES : To make a coloured floor the following materials should be mixed in the quantities stated, with every cubic metre of top layer cement concrete.

- Red : One twelveth cubic metre red oxide iron powder
Black : One sixth cubic metre manganese dioxide
Baff : One sixth cubic metre of yellow Ochre of Gopi.

SPECIFICATION NO. 39 G

FLOORING WITH 100MM CONCRETE AND 20MM CEMENT CONCRETE SURFACE ELLIS PATTERN

- (1) The 100 mm concrete base shall be prepared as detailed before under “General” For preparing the base I.S. : 2571 also shall apply
- (2) On the clean wet surface of the concrete base, before it has set, will be laid a layer of cement concrete to give a finished depth of 20mm over the lime concrete.

The cement concrete will consist of standard specification hard broken stone chippings, graded from gauges 3mm to 10 / mm and well mixed with standard specification. Cement neat, in he proportion 3 broken stone to 1 cement, or as otherwise specified instructed by the Executive Engineer.

Place
Date

Signature of the Bidder
(NAME & ADDRESS WITH SEAL)



BHARAT HEAVY ELECTRICALS LIMITED

POWER PLANT PIPING UNIT

THIRUMAYAM- 622 507

CONTRACTS DEPARTMENT

Phone : 04333279551

E.mail : ilango@bheltry.co.in Website : www.bhel.com

Tender No:PPPU:WC:14:015

Tender Notice

Dt. 04.10.2014

The cement concrete shall be spread immediately it has been mixed, using a straight edge. The concrete must be well beaten with 2.5 kg wooden 'thapies' until cement slurry comes to the surface say for not less than 15 minutes – and it is very important that the consolidation should be carried out quickly, as otherwise the initial set of the cement is likely to spoil the work , if the beating is continued too long or is not sufficiently through. When the mortar has come to the surface, the floor shall be polished with trowels.

- (3) To prevent large areas of cement concrete from cracking due to construction bonding setting, the floor shall be divided into strips extending across the width of the room, or into squares or rectangles 1.2 m. to 2.5 m in width. The edge of each section into which the floor is divided should be defined by flat bars of steel wood, their depth being the same as that proposed for the finished floor. They should be white washed in order to prevent them from adhering to the concrete When the slabs have set, the bars should be removed and the joints filled in, with standard specification cement mortar 1:2.
- (4) If it is desired to have a fine finish cement may be sprinkled over the surface of the concrete which has set and rubbed over with polishing stones.
- (5) After the floor has been completed, it should be covered with two inches of grass, sand or saw dust and kept wet for three weeks. It is better not to be brought into use for a month after laying.

Notes : (a) Then notes given under 39 F shall apply.

(b) Special care is necessary that the filling under the lime concrete is wetted and thoroughly consolidated in accordance with the standard specification for "filling" in basement" – as otherwise the whole floor is liable to crack.

SPECIFICATION NO. 39 H

FLOORING WITH CONCRETE 100 MM THICK AND PLASTERING OVER WITH CEMENT MORTAR 1:3 – 12 MM THICK

1. For flooring with cement concrete I.S. 2571 shall apply.
- 1.1. Standard specification cement plastering 1:3:12mm thick is to be applied to the floor before the concrete has set in order to obtain a good bond with the base.
2. Cement plaster gauges or other gauges should be put on the concrete floor about 3 metres apart to ensure even thickness.
3. Cement plastering must be done in squares or strips or also cracks will appear, if a large surface is done.

SPECIFICATION NO. 39 – I

FLOORING WITH RED CEMENT PLASTER, POLISHED SURFACE AND THREAD LINED

Place
Date

Signature of the Bidder
(NAME & ADDRESS WITH SEAL)



BHARAT HEAVY ELECTRICALS LIMITED

POWER PLANT PIPING UNIT

THIRUMAYAM- 622 507

CONTRACTS DEPARTMENT

Phone : 04333279551

E.mail : ilango@bheltry.co.in Website : www.bhel.com

Tender No:PPPU:WC:14:015

Tender Notice

Dt. 04.10.2014

- 1.1.The concrete base shall be well cleaned brushed free from any dust or loose concrete materials and then wetted. 1 Kg. of red oxide of iron per square metre of flooring shall be added to the cement mortar 1:3 and well incorporated during mixing and one coat of the mixture applied to the floor, otherwise conforming to the standard specification" Plastering with cement mortar". The plaster flooring shall be thread lined in squares diagonal to the sides of the room and size as instructed by the departmental officer in-charge of the work. The squares should be of equal size and finished off regularly at the edge or border around the room either at a corner or midline of the square. The surface shall be brought to a fine polished finish by the use of polishing stones.
2. The precautions against cracking and instructions for watering given in the standard specification for "Plastering with cement mortar" shall be followed

SPECIFICATION NO. 39 J

TERRAZO (MARBLE CHIPS) FLOORING LAID IN SITU

The thickness of the under layer shall be measured correct to a mm. the thickness of the top layer shall not be less than that specified.

- 1.1. Under layers : Cement concrete of specified mix shall be used and the specifications given below shall apply.

This shall be prepared by mixing graded stone or brick – aggregate of nominal size as specified proportions with required quantity of water.

The grading and quality of aggregates shall be such as to give minimum compressive strength of 140 Kg. cm and 210 Kg / cm at 7 days and 28 days respectively in case of mix 1:2:4.

One sample consisting of 6 cubes 15X15X15 cm. shall be taken for every 10 cubic metre or part thereof of cement concrete 1:2:4. The cube tests shall not be carried out in the case the quantity of cement concrete 1:2:4 placed on any day is less than 10 cu. m. unless otherwise specified. For other details refer "R.C.C. work".

The panels shall be of uniform size, not exceeding 2 sq.m in area and 2m. in length for inside situations. In exposed situations the length of any side of the panel shall not be more than 1.25 metres cement slurry at 2.00 Kg. per sq.m. shall be applied before laying of under layer over the cement concrete / R.C.C. Surface.

3. Top layer

- 3.1. Mortar – the mix for terrazzo topping shall consist cement with or without pigment, marble powder, marble aggregate (Marble chips) and water. The cement and marble powder shall be mixed in the proportion of 3 parts of cement to one part marble powder by weight. For

Place
Date

Signature of the Bidder
(NAME & ADDRESS WITH SEAL)



BHARAT HEAVY ELECTRICALS LIMITED

POWER PLANT PIPING UNIT

THIRUMAYAM- 622 507

CONTRACTS DEPARTMENT

Phone : 04333279551

E.mail : ilango@bheltry.co.in Website : www.bhel.com

Tender No:PPPU:WC:14:015

Tender Notice

Dt. 04.10.2014

every part of cement marble powder mix the proportion of aggregate by volume shall be as follows : -

Size of aggregates (1)	Proportion of aggregates to binder mix (2)
For grade 00,0 and 1	1.75 parts
For grade 2 and 3	1.50 parts
For grade 4 and 5	1.25 parts
Mixed size aggregate	1.50 parts

The marble chips shall be white or pink Makrana, black Bhainslana Chittor black, Jaisalmer Yellow, Baroda green, Denardun white, Chittor pink, yellow Patam Chera (Madras), grey Gadu (Surant) Chittor green and yellow and Alwar black or as specified. It shall be hard should, dense and homogeneous in texture, with crystalline and coarse grains. It shall be uniform in colour and free from strains, cracks, decay and weathering. The maximum thickness of the top layer for various sizes of marble aggregates (marble chips) shall be as under :

TABLE – 2

Grade Number	Size of aggregate in (mm)	Minimum thickness of top layer (mm)
00	1-2	6
0	2-4	9
1	4-7	9
2	7-10	12

Where aggregate of size larger than 10 mm are used the minimum thickness of topping shall not be less than 1 1/3 times the maximum size of the chips. Where large size chips such as 20mm or 25 mm. are used they shall be used only with a flat shape and bedded on the flat face so as to keep the minimum thickness of wearing layer.

Before starting the work, the contractor shall get the sample of marble chips approved by the Executive Engineer. The cement to be used shall be ordinary gray cement, white cement, coloured cement or cement with admixture of colouring matter of approved quality in the ratio specified in the description of the item or in the ratio to get the required shade as ordered by the Executive Engineer. Colouring matter where specified, shall be mixed dry thoroughly with the cement and marble powder and then marble chips added and mixed as specified above. The full quantity of dry mixture of mortar required for a room shall be prepared in a lot in order to ensure a uniform colour. This mixture shall be stored in a dry place and will covered and protected from moisture. The dry mortar shall be mixed with water in the usual way and when required. The mixed mortar shall be homogeneous and stiff and contain just sufficient water to make it workable.

Place
Date

Signature of the Bidder
(NAME & ADDRESS WITH SEAL)



BHARAT HEAVY ELECTRICALS LIMITED

POWER PLANT PIPING UNIT

THIRUMAYAM- 622 507

CONTRACTS DEPARTMENT

Phone : 04333279551

E.mail : ilango@bheltry.co.in Website : www.bhel.com

Tender No:PPPU:WC:14:015

Tender Notice

Dt. 04.10.2014

The terrazzo topping shall be laid while the under layer is still plastic, but has hardened sufficiently to prevent cement from rising to the surface, this is normally achieved between 18 to 24 hours after the under layer has been laid. A cement slurry preferably of the same colour as the topping shall be brushed on the surface immediately before laying is commenced. It shall be laid to a uniform thickness slightly more than that specified in order to get the specified finished thickness after rubbing. The surface of the top layer shall be trowelled over, pressed and brought true to required level by a straight edge and steel gloats in such a manner that the maximum amount of marble chips come up and are spread uniformly over the surface.

3.2. Polishing, curing and finishing – polishing shall be done by machine. About 36 hours after laying the top layer. The surface shall be watered and ground evenly with machine fitted with special rapid cutting grit blocks (carborundum stone) of coarse grade (No.60) till the marble chips are evenly exposed and the floor is smooth. After the first grinding mud and covered with a grout of cement or / and colouring matter in same mix and proportion as the topping in order to fill any pin holes that appear. The surface shall be allowed to cure for 5 to 7 days and then ground with machine fitted with fine grit blocks (No.120). The surface is cleaned and repaired as before and allowed to cure again for 3 to 5 days. Finally the third grinding fall be done with machine fitted with fine grade grit blocks (No.320) to get even and smooth surface without pin holes. The finished surface should show the marble chips evenly exposed.

Where use of machine for polishing is not feasible or possible, rubbing, and polishing shall be done by lard, in the same manner as specified for machine polishing except that carborundum store of coarse grade (No.60) shall be used for the 1st rubbing, stone of medium grade (No.80) for second rubbing and stone of fine grade (No.120) for final rubbing and polishing.

After the final polish either by machine or by hand, oxalic acid shall be dusted over the surface at 33 gm per square metre sprinkled with water and rubbed hard with a namdah block (Pad of woolen rags) . the following day, the floor shall be wiped with a moist rag and dried with a soft cloth and finished clean.

Curing shall be done by suitable means, such a laying moist saw dust or ponding water.

4. Precautions : Flooring in lavatories and bathrooms shall be laid after fixing of water closet and squatting pans and floor traps. Traps shall be plugged, while laying the floors and opened after the floors are cured and cleaned. Any damaged done to W.Cs squatting pans and floor traps during the execution of work shall by made good of the Contractor.

During cold weather, concreting shall not be done when the temperature falls below 4° C. The concrete placed shall be protected against frost by suitable covering. Concrete damaged by frost shall be removed and work redone. During hot weather, precautions shall be taken to see that the temperature of wet concrete does not exceed 38°C. No concreting shall be laid within half an hour of the closing time of the day, unless permitted by the executive Engineer.

The floor shall be protected from any damage during the execution of work.

Place
Date

Signature of the Bidder
(NAME & ADDRESS WITH SEAL)



BHARAT HEAVY ELECTRICALS LIMITED

POWER PLANT PIPING UNIT

THIRUMAYAM- 622 507

CONTRACTS DEPARTMENT

Phone : 04333279551

E.mail : ilango@bheltry.co.in Website : www.bhel.com

Tender No:PPPU:WC:14:015

Tender Notice

Dt. 04.10.2014

5. Measurements

5.1. Length and breadth shall be measured correct to a c.m. before laying skirting , dado or wall plaster. The area as laid shall be calculated in square metre correct to two places of decimal. No deduction shall be made nor extra paid for any opening in floor of area upto 0.1. square (10dm²). Nothing extra shall be paid for paying the floor at different levels in the same room or courtyard mortar, neat gray cement slurry or honey like consistency shall be spread over the mortar at the rate of 4.4 kg of cement per square metre over each thread. Tiles shall be washed clean and shall be fixed in this grout one at another, each tile being gently tapped with a wooden mallet till it is properly bedded, and in level and line with the adjoining tiles. The joints shall be kept as thin as possible and in straight lines. The surface shall be checked with a straight edge during laying to obtain a true surface.

12-2.2 : The square end of the tile shall, as far as possible butt against the riser face of the concrete or brick tread and in any case shall be embedded under the side wall plaster skirting of dado and under the riser tile or other finish to a depth of not less than 10 mm.

12.2.4 : After the tiles have been laid surplus cement grout shall be cleaned off.

12.3. Curing polishing and finishing – The specifications shall be as described in 39-J-73 except that polishing of the treads nosing and chequered grooves, after laying, may be done by hand in the same manner specified under terrazzo tile flooring. Special care shall be taken polish the nosing and the grooves in such a manner as to get a uniform section for the grooves and the nosing and their finish shall match with the finish of the flat portion of the tiles.

12.4. Measurements – Chequered tiles on stair treads shall be insured in square metre correct to two places of decimal. Length shall be measured from the finished face of skirting, dado or all plaster as the case may be, correct to a cm. Width shall be measured from the outer edge of the tread to the finished face of riser or in the case of the edge tiles of the landing and wide steps, to the near edge of the chequered stair tread tile.

12.5. Rates – the rate shall include the cost of all material sand labour involved in all operations described above. No extra shall be payable for cutting the tiles to the size of trends and also for nosing.

SPECIFICAITON NO. 40

BEST TERRACED FLOORING WITH BRICK ON EDGE 75 mm

CONCRETE AND 12 mm. CEMENT PLASTERING 1:3 TO TOP AND BOTTOM

1.1. I.S. : 2199 shall apply.

2. The flooring will be carried into the walls for 15 cm. except for interior cross walls where the flooring will be carried through the width of the wall and continued in the adjoining room in cases where such rooms are terrace floored.

Place
Date

Signature of the Bidder
(NAME & ADDRESS WITH SEAL)



BHARAT HEAVY ELECTRICALS LIMITED

POWER PLANT PIPING UNIT

THIRUMAYAM- 622 507

CONTRACTS DEPARTMENT

Phone : 04333279551

E.mail : ilango@bheltry.co.in Website : www.bhel.com

Tender No:PPPU:WC:14:015

Tender Notice

Dt. 04.10.2014

2.1. The finished surface of the flooring must be perfectly level unless a slope for drainage is specified or instructed to be given by the Executive Engineer. The portion of flooring in set into walls will be paid for as walling and not as flooring

SPECIFICATION NO. 41

**BEST TERRACED FLOORING WITH BRICK ON EDGE , 75mm
CONCRETE 12 mm CEMENT PLASTERING 1:3 TO BOTTOM
AND ON TOP PRESSED TILES SET IN LIME MORTAR AND POINTED WITH CEMENT MORTAR 1:3**

1.1 I.S. : 2119 2 and I.S. : 1237 and I.S. : 1443 shall apply,

SPECIFICATION NO. 42

FLOORING WITH GRAVEL 15 cm THICK

1.1. After completion of the bed in accordance with the standard specification for "Filling in basement" level or sloped as shown in the sanctioned plans or ordered by the Executive Engineer, standard specification gravel shall be mixed with sand in the proportion of 9:5 (nine gravel and five sand) and with water and worked with mammooties till it can be formed into stiff plastic balls. It shall then be laid in one thickness and well rammed with flat iron or wooden rammers the finished depth of the gravel shall be 15 cm.

SPECIFICATION NO. 43

Teakwood Flooring 40 mm Thick

1.1. I.S.: 3670 and N.B. Code Parts V,VI and VII of appendix shall apply.

Extract form I.S. 5766

Code of practice for laying burnt clay brick flooring.

6.3 Laying the bricks.

6.3.1. Soaking of Bricks – To reduce excessive section, the bricks before being laid shall be soaked in clean water and then allowed to drain until they are surface dry.

6.3.2. The bricks shall be laid in plain, diagonal, herringbone or other suitable patterns. The bricks shall either be laid flat or on edge. Damaged bricks shall not be used. Broken bricks shall not be used in flooring except for closing a line.

Bricks shall be laid on lime mortar or cement mortar bed and each brick shall be properly bedded flat or on edge and set by gentle rapping with handle of trowel or wooden mallet. The inside faces of the bricks shall be smeared with mortar, before the next brick is laid and pressed against it. on completion of a portion of flooring, the vertical joints shall be fully filled with mortar from the top. The surface of the flooring during laying, shall be frequently checked with a straight edge at least 2m long, so as to obtain a true surface with the required slope. In case of

Place
Date

Signature of the Bidder
(NAME & ADDRESS WITH SEAL)



BHARAT HEAVY ELECTRICALS LIMITED

POWER PLANT PIPING UNIT

THIRUMAYAM- 622 507

CONTRACTS DEPARTMENT

Phone : 04333279551

E.mail : ilango@bheltry.co.in Website : www.bhel.com

Tender No:PPPU:WC:14:015

Tender Notice

Dt. 04.10.2014

flat brick flooring, bricks shall be laid with frog down. When the laid flat is plain courses, the units shall be break joints at half the length of the bricks.

6.4 Joints – Bricks shall be so laid that all the joints are full of mortar. The thickness of the joints shall be between 8 to 10 mm. The joints shall be flush pointed after being raked out 10mm. deep while the mortar is still green. The raked joints shall be well brushed to remove dust and loose particles and well wetted; and shall be refilled with cement mortar (1 cement : 2 sand).

6.5 Curing – The flooring shall be kept wet for at least 7 days after completion. In case of cement lime mortar, curing shall commence two days after the laying and shall continue for seven days.

Code of practice for laying in situ granolithic concrete floor topping.

0.1 forward.

0.2 Granolithic concrete floor topping is adopted for floors of heavy engineering factories, workshops, garages, warehouses, etc., where the floor is subjected to heavy loads and severe abrasion combined with impact. The granolithic concrete made with specially selected aggregate of high hardness, surface texture and particle shape suitable for use as a wearing finish to floors. Although plain concrete as laid conforming to I.S.2571 would be satisfactory for many purposes granolithic concrete is chosen because of its high abrasion resistance and used for floor toppings wherever abrasion combined with impact is likely to be severe.

4.4. Mix proportions – Mix proportion for the granolithic concrete floor topping for different types of floor finish shall be 1:1:2 (Cement : fine aggregate : coarse aggregate, by volume).

7.1 Floor Topping laid Monolithically with the suspended slab.

Note(1). – In the monolithic method of construction the granolithic concrete floor topping may be regarded as contributing to the structural strength of the suspended floor.

Note (2) – The monolithic construction of granolithic concrete floor topping presents certain difficulties in construction due to other activities, such as plastering of walls and ceilings, fixing of joinery, movement of scaffoldings, ladders, etc., which are likely to damage the floor finish.

7.3. Floor Topping laid over cushioning layer (See Table 3):

Note – Where lime and good quality of bricks are not available 1:4:8 cement concrete may be used.

**Table 3 – DIFFERENT TYPES OF GRANOLITHIC CONCRETE FLOOR TOPPING.
(Clauses 6.1., 6.2 and 7.1 to 7.3)**

Place
Date

Signature of the Bidder
(NAME & ADDRESS WITH SEAL)



BHARAT HEAVY ELECTRICALS LIMITED

POWER PLANT PIPING UNIT

THIRUMAYAM- 622 507

CONTRACTS DEPARTMENT

Phone : 04333279551

E.mail : ilango@bheltry.co.in Website : www.bhel.com

Tender No:PPPU:WC:14:015

Tender Notice

Dt. 04.10.2014

Serial Number and Type floor topping.	Thickness of granolithic concrete floor topping in mm, min.	Remarks.
---------------------------------------	---	----------

(1)

(2)

(3)

A. Floor topping laid over base concrete on ground.

- | | | |
|---|----|--|
| 1. Floor topping laid monolithically with | 20 | Granolithic base concrete floor topping shall be laid monolithic with the base concrete |
| 2. Floor topping laid separately on hardened base concrete. | 40 | Granolithic concrete floor topping shall be laid separately over specially prepared surface of set and hardened base concrete. |

Serial Number and Type floor topping.	Thickness of granolithic concrete floor topping in mm, min.	Remarks.
---------------------------------------	---	----------

B. Floor topping laid over suspended slabs.

- | | | |
|---|----|---|
| 3. Floor topping laid monolithically with the suspended slab. | 20 | The granolithic concrete topping shall be laid and finished monolithic with the suspended slab. For this purpose the topping shall be laid immediately after the structural concrete of the suspended slab has stiffened enough (but is still green) to tread over it by placing ranks. |
| 4. Floor topping laid over the hardened suspended slab. | 40 | The topping shall be laid separately over specially prepared surface of set and hardened suspended slab. |
| 5. Floor topping laid over cushioning layer | 40 | Cushioning layer of lime concrete of 40 to 50 mm thickness shall be laid over the prepared surface of suspended slab. Granolithic concrete topping shall be laid as in 4. |

Place
Date

Signature of the Bidder
(NAME & ADDRESS WITH SEAL)



BHARAT HEAVY ELECTRICALS LIMITED

POWER PLANT PIPING UNIT

THIRUMAYAM- 622 507

CONTRACTS DEPARTMENT

Phone : 04333279551

E.mail : ilango@bheltry.co.in Website : www.bhel.com

Tender No:PPPU:WC:14:015

Tender Notice

Dt. 04.10.2014

8. Curing :

8.1. Immediately after the flooring surface is finished it shall be protected from rapid drying, by erecting barriers against win of draught and strong sunlight. As soon as the surface had hardened sufficiently to prevent damage to it shall be kept continuously moist for at least ten days by means of wet gunny bags, 50 mm thick layer of damp and spread over the surface or pooling water on the surface : During this period the flooring shall not be exposed to any traffic premature exposure to traffic will lead to damage to the surface which cannot be satisfactorily repaired.

EXTRACT FROM I.S. 2571

Code of practice for laying in situ cement concrete flooring
(First Revision)

0.1 Forward

0.2. In situ cement concrete flooring consists essentially of rich cement concrete , and possesses good wearing properties and facility of easy cleaning and maintenance which make it suitable for use in houses, schools, hospitals and light industrial buildings. Depending upon the amount of loading and the degree of wear resistance needed, the floor finish has to be laid in various thickness and a careful selection has to be made regarding mix proportions panel sizes and number of layers. Also the laying operations have to ensure the proper bonding of the finish to the base of sub-floor . This code provides necessary guidance in the selection of materials and laying and finishing of cement concrete flooring for obtaining satisfactory performance.

4.2.1.1. Coarse aggregate : - The grading of graded coarse aggregate for cement concrete flooring mix shall be within the limits given in table 1. The coarse aggregate shall generally be the following sizes : -

(a) Base concrete (lean Graded from 40 mm and below cement concrete or lime concrete)

(b) Cement concrete topping Graded from 16 mm and below of thickness 40 mm and above.

(c) Cement concrete topping Graded from 12.5 mm and below of thickness 25 mm.

(d) Under layer of cement Grade from 12.5 mm and below concrete topping two layers.

2. The tiles used were 20 cm. $\frac{12.5 \text{ cm} + 10 \text{ cm}}{2} \times 9 \text{ mm}$ – with

2

a curvature of 30 mm measured at the center of the title. The number of these tiles required for one square metre of roofing on the above basis was counted and found to be 1.650 without allowance for breakings.

3. For slopes of longer lengths than noted above, it will usually be advisable to adopt other type of roofing or break the slope, by a drop in the roof, carrying away the run – off from the upper part of the roof by guttering.

Place
Date

Signature of the Bidder
(NAME & ADDRESS WITH SEAL)



BHARAT HEAVY ELECTRICALS LIMITED

POWER PLANT PIPING UNIT

THIRUMAYAM- 622 507

CONTRACTS DEPARTMENT

Phone : 04333279551

E.mail : ilango@bheltry.co.in Website : www.bhel.com

Tender No:PPPU:WC:14:015

Tender Notice

Dt. 04.10.2014

SPECIFICATION NO. 44 – E

BEST TILED ROOFING WITH MANGALORE TILES INCLUDING TEAK OR COUNTRY WOOD REFERS

1. Clauses additional to “General” Preceding I.S. 2858 shall apply.
2. If it is specifically stated in the Schedule item description or in the specifications that ventilating tiles are to be provided, then two ventilating tiles to every 10 square metres of finished roof surface shall be provided at places pointed out by the Executive Engineer. The ventilating tiles shall be of Standard pattern and make approved by Executing Engineer and shall be the same colour as the other tiles and well burnt. They shall fit close and tight with the other tiles ; the rate for the roofing shall include the cost of the ventilating tiles in such case as they are specified to be provided.
3. The roofing rate does not include the cost of galvanized iron sheet but it shall include labour, etc. for fixing.

SPECIFICATION NO. 44 – G

TERRACED ROOFING WITH BRICK ON EDGE, 75 MM. CONCRETE, TWO COURSES OF FLAT TILES IN C.M. 1:3 TO TOP AND ONE COAT OF CEMENT PLASTER 1:3 TO BOTTOM.

1. Clauses additional to General Preceding. I.S. 2119 / 62 . 3036 / 65 and N.B.C. Parts V, VII Appendices shall apply.
2. After six days or after the concrete laid has preened two courses of flat tiles shall be laid in cement mortar 1:3 mixed with crude oil. The mortar shall be prepared as instructed in S.S. 45 except that the crude oil is to be in the proportion of 10 per cent of the weight of the cement. The tiles shall be laid first course diagonally and the second course square to the parapet thus breaking Joint. The side Joint of tiles shall not be more than 6 mm thick set full mortar. The mortar layer bed over the roof slab shall not be less than 9 mm finished thickness after receiving the first layer of tiles and 9 mm thick mortar bed between the two layers of tiles. The flat tiles shall be immersed in water for two hours before being used. The tiles shall be laid and finished off as instructed in SS 44 – H.
3. Before the work dries up completely, the tile joints shall be raked out and pointed over with cement mortar 1:3 mixed with crude oil prepared as instructed in clause 2 Supra. The joints shall be well rubbed over thin bar trowels and the excess of mortar scrapped off until the surface of the pointing attains a black polish and becomes hard. The ceiling shall be plastered with one coat of Standard specification “Plastering with cement mortar 1:3,12 mm. thick – S.S. No.56. Clauses relating to the perishing of mortar and providing proper openings of drains in S.S. 44 – G shall apply to this S.S. also.

SPECIFICATION NO. 44-H

REINFORCED CONCRETE ROOFING AND TWO COURSES OF FLAT TILES TO TOP

Place
Date

Signature of the Bidder
(NAME & ADDRESS WITH SEAL)



BHARAT HEAVY ELECTRICALS LIMITED

POWER PLANT PIPING UNIT

THIRUMAYAM- 622 507

CONTRACTS DEPARTMENT

Phone : 04333279551

E.mail : ilango@bheltry.co.in Website : www.bhel.com

Tender No:PPPU:WC:14:015

Tender Notice

Dt. 04.10.2014

1. Clauses additional to "General Preceding"
The reinforced concrete roofing shall be laid as per I.S. 456 and N.B. Code Part VI Section 5. For extracts of I.S. See Section 4.
2. The reinforced concrete roof slab will itself be laid wherever possible at the required slope a secure proper drainage of the roof. This slope will be defined in the relevant plans or specified by the Executive Engineer. When the required slope has to be given by means of camber concrete over girders, this concrete – of the same mix as the floor slab - will be formed on the R.S. beams or on the Tee beams, as the case may be, along with the roof slab. The forms of the roof slab and the girders shall be so adjusted as to enable the moulding of the camber concrete en-mass with the roof slab. This camber concrete shall be considered as included in the square metre rate for the roofing unless other method of payment is in the Schedule.
3. As soon as the setting period for the roof slab is over the top of the slab shall be thoroughly cleaned and wetted. Two courses of 20 mm thick flat tiles shall be laid in cement mortar 1:3 mixed with crude oil and pointed in the same manner as instructed in clauses 2 and 3 of S.S. No. 44-G.
4. As the work proceeds it shall be kept thoroughly wetted until the mortar has set firm and hard. Watering shall be continued for three weeks after construction.
5. Clauses relating to the perishing of mortar and leaving proper opening for drains in S.S. 44 – F shall apply to this specification also.
6. Payment shall be per 10 sq. metres superficial area on the completed roofing and the rate shall be either inclusive or exclusive of R.C. slab concrete as the case may be according to conditions in the tender schedule – Wide also remarks in clause 2 supra regarding camber concrete, the bearing of the slab shall be not less than 15 cm. or the depth of the slab without the surface, whichever is greater. This area of bearing only shall be paid for at the roof slab rate irrespective of the actual bearing when this is greater, unless otherwise specifically defined in writing before a contract is entered into. Corresponding deduction for wall masonry work will be made. If the roof slab is carried continuous over the wall to form a cornice or chajja, then the roof slab shall be measured as instructed and payment for the cornice or chajja portion will be defined in Schedule A of the contract on the lineal metre basis, or as may be otherwise specified, and shall include the portion bearing on the wall apart from that specified above payment as roof slab.
7. If the parapet wall is of 20 cm. thick and more than two courses of flat tiles shall be laid continuous upto 50 mm. through the parapet wall. In addition to this , along the junction of the parapet and roof, tiles shall be laid inclined at 45 to the face of the parapet after laying necessary brick jelly concrete (wide Fig 8-10. The inclined tiles also should be taken inside the wall for a depth of 50mm.

Place
Date

Signature of the Bidder
(NAME & ADDRESS WITH SEAL)



BHARAT HEAVY ELECTRICALS LIMITED

POWER PLANT PIPING UNIT

THIRUMAYAM- 622 507

CONTRACTS DEPARTMENT

Phone : 04333279551

E.mail : ilango@bheltry.co.in Website : www.bhel.com

Tender No:PPPU:WC:14:015

Tender Notice

Dt. 04.10.2014

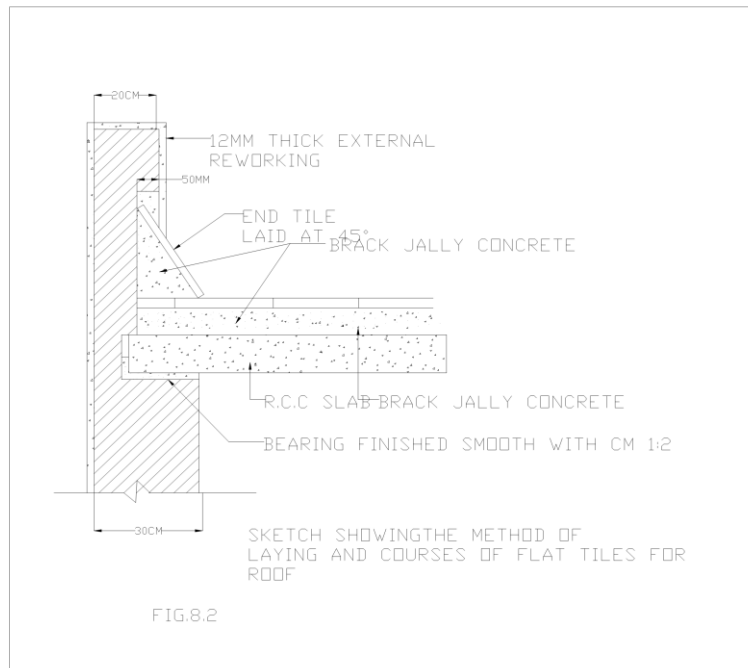
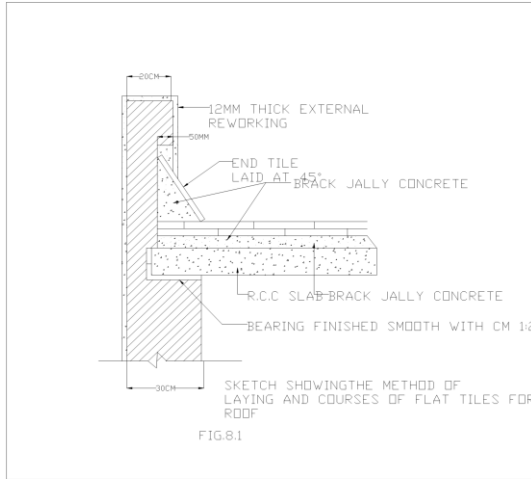

Place
Date

Signature of the Bidder
(NAME & ADDRESS WITH SEAL)



BHARAT HEAVY ELECTRICALS LIMITED

POWER PLANT PIPING UNIT

THIRUMAYAM- 622 507

CONTRACTS DEPARTMENT

Phone : 04333279551

E.mail : ilango@bheltry.co.in Website : www.bhel.com

Tender No:PPPU:WC:14:015

Tender Notice

Dt. 04.10.2014

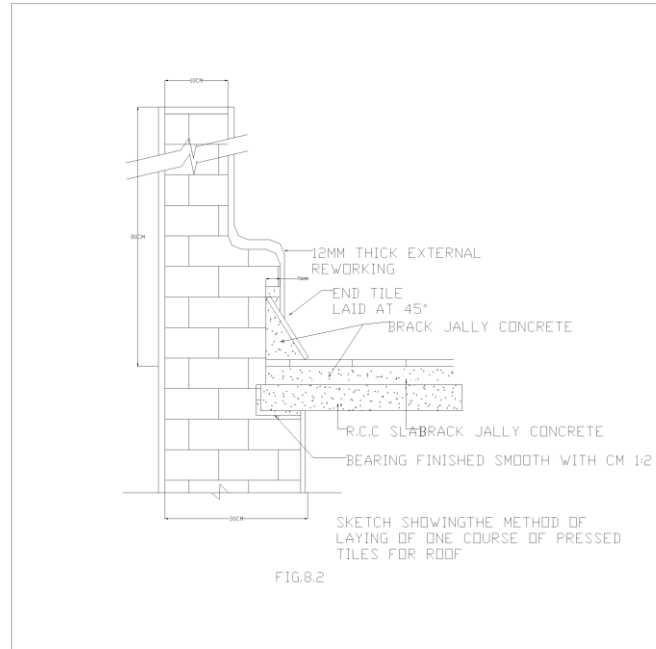

9. If the parapet wall is of 10 cm. thick and more than two courses of flat tiles shall be laid continuous upto 50mm. through the parapet wall. In addition to this, along the junction of the parapet and roof, tiles shall be laid inclined at 45 to the face of the parapet after laying necessary brick jelly concrete (Vide Fid. 8-1). The inclined tiles also should be taken inside the wall for a depth of 50 mm.
10. Where facia work in concrete is adopted instead of parapet wall, then a 20 cm. thick brick work shall be built behind the facia work for a height of 30 cm. Laying of tiles shall be similar to the specification described above for 20 cm wall (Fig. 8-4)
11. Plastering of the parapet shall be done only after the tiles are laid.
12. The area of the tiles for which payment is to be made shall be the exposed area of the tiles at top. The contract shall therefore quote his unit rate accordingly.
13. The additional brick jelly concrete and tiles at the junction of the parapet with roof shall be measured and paid for separately.

SECTION IX

PLASTERING, POINTING, WHITE WASHING, COLOUR WASHING AND DISTEMPERING INDIAN STANDARD EXTRACTS

I.S. Number	
-------------	--

Place
Date

Signature of the Bidder
(NAME & ADDRESS WITH SEAL)



BHARAT HEAVY ELECTRICALS LIMITED

POWER PLANT PIPING UNIT

THIRUMAYAM- 622 507

CONTRACTS DEPARTMENT

Phone : 04333279551

E.mail : ilango@bheltry.co.in Website : www.bhel.com

Tender No:PPPU:WC:14:015

Tender Notice

Dt. 04.10.2014

5410	Specification for Cement Paint, Colour as required
427	Specification for Distemper, Dry Colour as required
428	Specification for Distemper, Oil emulsion, Colour as required
1200	Method of Measurement of Building and Civil Engineering Works – Part XII – Plastering pointing
1597	Code of practice for Construction of Stone Masonry – Part I - Rubble Stone Masonry
1661	Code of practice for Cement and Cement – lime Plaster Finishes on Walls and Ceilings
2394	Code of practice for application of Lime Plaster finish
2402	Code of practice for external rendered finishes
6278	Code of practice for White Washing and Colour Washing

SPECIFICATION NO.56 AND 57

PLASTERING WITH CEMENT MORTAR

- 1.1. For plastering stone masonry, the specifications laid down in I.S. 1661 shall apply.
2. Should the mortar crack or perish through neglect of watering or for other fault of the contractor, the work shall be removed and redone at the contractor's expense or should the contractor fail to water the work to the satisfaction of the officer – in – charge of the work the latter may supply the requisite men to water to the work properly and charge the cost to the contractor.
3. Where thread lining is to be done, it shall be done to the instructions of the Executive Engineer.
4. Vertical joints will be finished with a hard skin similar to the horizontal joints, only flush and not struck vide sketch below for brick work :-
5. Random rubble joints will be finished flush in the absence of any modifying specification or schedule item, i.e. pressing the mortar well into the joint and rubbing smooth as in clause 2 above, restricting the mortar to the width of the joint – finished joint surface being flush with the face of the wall.
6. No extra payment over the rate for masonry will be paid for the method of finishing joints described above
7. Finishing joints as described above is all that is necessary and done while the work is in progress, before the mortar has set, the joints look as well and neat as any pointing.

SPECIFICATION NO. 62

POINTING WITH CEMENT MORTAR (1 : 3)

- 1.1. the work shall be executed as specified for "Pointing with mortar " except that Portland Cement mortar using 1 Portland Cement and 3 sand, and conforming to the standard specification for Portland Cement mortar, shall be used instead of lime mortar. The work shall be executed as rapidly as possible (and not again touched, after it has begun to set) and kept wet for 7 days

Place
Date

Signature of the Bidder
(NAME & ADDRESS WITH SEAL)



BHARAT HEAVY ELECTRICALS LIMITED

POWER PLANT PIPING UNIT

THIRUMAYAM- 622 507

CONTRACTS DEPARTMENT

Phone : 04333279551

E.mail : ilango@bheltry.co.in Website : www.bhel.com

Tender No:PPPU:WC:14:015

Tender Notice

Dt. 04.10.2014

thereafter. If other proportion of cement mortar is to be used, it will be so defined in the relevant schedule item.

SPECIFICATION NO. 63 WHITE WASHING

- 1.1. Specification laid down in I.S. 6278 shall apply.
2. Each coat of the white wash is to be allowed to dry and should be inspected by the Subordinate in charge before applying the next coat.
3. The contractor shall take precaution to prevent white wash being splashed on the wall, floor and other surfaces and articles not to be white washed. The contractor shall clean all such items to the satisfaction of the Executing Engineer at his own cost. Ladders, poles, scaffolding, etc., shall be shoed with gunny bags to prevent damage or scratching of the walls and floor.

SPECIFICATION NO. 64 COLOUR WASHING

- 1.1. Specifications laid down in I.S. 6278 shall apply.

SPECIFICATION NO. 65 DISTEMPERING

- 1.1. specification for distempers laid down in I.S. 427 and I.S. 428 shall apply.
- 1.2. Wall Surface : - Plaster should present a fine polished surface and be absolutely dry before distempering is commenced. The walls must be well – cleaned down as no pleasing effect can ever result from the use of distemper unless the ground to be worked upon is perfectly clean. Inequalities and small holes such as nail holes shall be filled with gypsum, and allowed to set hard before the distemper is applied. No extra payment will be given for this cleaning and filling, unless there is separate schedule provision made for the same, in view of the magnitude of the work to be done
2. Mixing - Unless otherwise ordered by the Executing Engineer the mixing of the distemper shall be carried out in accordance with the instructions issued by the manufacturers of the particular brand of distemper that is specified to be used.
3. **Application**
 - 3.1. One coat shall be applied unless otherwise defined in the relevant schedule item or otherwise ordered by the Executive Engineer. In applying, dip the brush in the distemper and stroke crosswise on the wall and immediately stroke perpendicularly, then stop.
 - 3.2. It is recommended that two men shall work together one going round the room applying the distemper from the ceiling downwards as far as he can reach; and the second man following him applying the distemper below.
 - 3.3. In this way, it is easier to join up and avoid patchy overlaps.

4. Brushes

Place
Date

Signature of the Bidder
(NAME & ADDRESS WITH SEAL)



BHARAT HEAVY ELECTRICALS LIMITED

POWER PLANT PIPING UNIT

THIRUMAYAM- 622 507

CONTRACTS DEPARTMENT

Phone : 04333279551

E.mail : ilango@bheltry.co.in Website : www.bhel.com

Tender No:PPPU:WC:14:015

Tender Notice

Dt. 04.10.2014

- 4.1. The contractor shall use proper distemper brushes as supplied by firms dealing in distemper. The brushes shall, each day after work, be washed in hot water and hung up to dry.
- 4.2. Old brushes caked with dry distemper shall not be allowed on the work

Notes on distempers

- (a) None of the distempers will stand exposure to heavy rain, nor can any of them be described as washable. No attempt should be made to wash distempers during the monsoon.
- (b) Distempers should, however, only be used in dry climates as they give poor results in wet localities. To get the full advantage out of these distempers, it is necessary to apply a priming coat as recommended by the makers. Distempers grow dark with age.
- (c) Distempers should not be mixed in a larger quantity than is actually required for day's work and hot water should be used in preference to cold water in preparing the mixture.
- (d) On new lime plastered walls, distempers should be applied in two coats over one coat of priming
- (e) On old lime plastered walls covered with one or two coats of hard dry white wash free from efflorescence or "kalar". One coat of distemper without priming should be used but only distempers which are lime-proof should be used.
- (f) When the lime plaster is very smooth and no priming coat is used, a coating of warm glue should first be applied, but if rough, a coat of Spanish white or chalk mixed with a solution of glue is employed to render the surface smooth, the coating when dry, being rubbed as clean and as even as possible.
- (g) For local made distempers a priming coat of milk (0.75 kg . per 10 m²) may be used with good results.
- (h) Distempers should be applied in dry weather with a broad stiff brush, and the first sort coat should be allowed to thoroughly dry before the next is laid on. The first coat should always be of a lighter tint and should be applied with care. The brushes used should never be allowed to rest on the bristles and after use they should be carefully and thoroughly cleaned.

SPECIFICATION NO. 65-A

CEMENT PAINTING

- (1) Specification for cement paint laid down in I.S. 5410 shall apply.
- (2) Surface preparation – Any previous coating, lime work, loose materials and dirt shall be removed thoroughly by scrapping and washing. In case where cement paint was previously used, only a slight scrapping with sand paper is necessary to remove all fungus, or organic matters which may be present

The surface shall be wet thoroughly with clean water. When the surface starts drying and there is no sign of water on the wall. (The surface must feel damp to touch) the surface is ready for application.

Place
Date

Signature of the Bidder
(NAME & ADDRESS WITH SEAL)



BHARAT HEAVY ELECTRICALS LIMITED

POWER PLANT PIPING UNIT

THIRUMAYAM- 622 507

CONTRACTS DEPARTMENT

Phone : 04333279551

E.mail : ilango@bheltry.co.in Website : www.bhel.com

Tender No:PPPU:WC:14:015

Tender Notice

Dt. 04.10.2014

NOTE : On a new surface or in very dry atmosphere where the water is either sucked in or evaporated very fast, wet the surface with water until a uniform drying is noted. Concentrate only on those parts which are drying earlier than the rest carry on until uniformity in drying is observed.

(3) Mixing – Unless otherwise ordered by the Executing Engineer the mixing of the cement paint shall be carried out in accordance with the instructions issued by the manufacturers of the particular brand of cement paint that is specified to be used.

(4) Application – The water mixed cement paint shall be kept well stirred before and during use and shall be applied within one hour of preparation. Use flat brush and more horizontally or vertically to ensure perfect covering. While applying the first coat brush hard into the surface to seal up all cavities or pores which may be present. For the second coat apply similarly but finish with a vertical movement taking care to see that the paint is spread evenly over the surface. During application frequent stirring should be done to ensure homogeneous composition.

(5) Curing – 24 hours after the first coat has been applied the surface shall be saturated with water. The second coat shall be applied when the surface is damp to touch. Re watering the surface shall be done with ample water after 24 hours to ensure perfect setting of the paint film.

The number of coats necessary shall be as decided by the Executive Engineer

(6) Weather – Wherever possible, the application of cement paint shall take place in the shade. If this is impossible, the painted surface shall be wetted with a fine water spray after 4 to 5 hours. Painting during rainy seasons shall be done taking precaution that the painted surface are not hit by rain for a minimum of 3 to 4 hours as the paints are liable to wash off if rain occurs, within two to three hours.

EXTRACT FROM I.S. 5410

Specification for cement paint, colour as required

1. Scope

1.1. This standard prescribes the requirements and the methods of sampling and test for cement paint, colour as required. The material is intended for use on walls, ceilings and as an interior or exterior decorative and protective finish.

2. Terminology

2.1. For the purpose of this standard, the definitions given in, I.S. : 1303 shall apply

3. Requirements :-

3.1. Composition – The material, on analysis as prescribed in appendix A, shall show a chemical composition as given below. The composition of the bulk supply shall be similar to that of registered sample

	Percent by weight
--	-------------------

Place
Date

Signature of the Bidder
(NAME & ADDRESS WITH SEAL)



BHARAT HEAVY ELECTRICALS LIMITED

POWER PLANT PIPING UNIT

THIRUMAYAM- 622 507

CONTRACTS DEPARTMENT

Phone : 04333279551

E.mail : ilango@bheltry.co.in Website : www.bhel.com

Tender No:PPPU:WC:14:015

Tender Notice

Dt. 04.10.2014

Portland cement	60 min
Hyderated lime	25 mix
Alkali resistance pigment	3 to 7
Water repellants hygroscopic salts fungicides	In suitable proportions to produce a material to satisfy the requirements of this standard

SECTION X

PAINTING, VARNISHING, ETC. INDIAN STANDARD – EXTRACTS

I.S. Number	
75-	Specification for Licensed Oil Raw and Refined
77	Specification for Licensed Oil Boiled for Paints
78	Specification for Licensed Oil Boiled for Paints
86	Specification Oil Paste for Paints to Indian Standard Colours
110	Specification for Ready mixed Paint, Brushing, Frey filler, for Enamels, for use over Primers
212	Specification for Crude Coal tar for General Use
337	Specification for Varnish, Finishing Interior
338	Specification for Varnish, under coating, Exterior, Natural Resin
340	Specification for Varnish Mixing
347	Specification for Varnish, Shellac for General Purposes
533	Specification for Gum Spirit of Turpentine (Oil of Turpentine)
1200	Method of Measurement of Building and Civil Engineering Works, (Part XV) Painting
1477	Code of practice for Painting of Ferrous metals in Buildings and Allied finishes (Part I) Pretreatment
1477	(Part II) – Painting
2338	Code of practice for finishing of Wood and Wood Based Materials (Part I) Operations and Workmanship
	(Part II) Schedules
2395	Code of Practice for Painting, Concrete Masonry and Plaster Surfaces (Part I) Operations and Workmanship
C.P.W.D.	Specification for painting

Place
Date

Signature of the Bidder
(NAME & ADDRESS WITH SEAL)



BHARAT HEAVY ELECTRICALS LIMITED

POWER PLANT PIPING UNIT

THIRUMAYAM- 622 507

CONTRACTS DEPARTMENT

Phone : 04333279551

E.mail : ilango@bheltry.co.in Website : www.bhel.com

Tender No:PPPU:WC:14:015

Tender Notice

Dt. 04.10.2014

SECTION X

PAINTING, VARNISHING, etc.

SPECIFICATION NO. 66

PAINTING

1. Materials – (a) All paints, oils and other materials and labour for the painting shall be provided by the contractor and included in his rate per 10 square metre, unless otherwise defined in the scheduled item wording or relevant supplementary specification.

NOTE : In most cases, the Executing Engineer will issue the paints, raw and boiled licensed oil and other ingredients at a place and price to be noted in the tender notice and the tenderer will be asked to quote his price for finished work based on the above departmental supply.

- (b) When the contractor is specifically permitted to obtain the paint by direct purchase and not by purchase from the department the paint shall be obtained by the contractor, and inspected by the Public Works Department officer in charge of the work, in the original containers as issued by the manufacturer, before the containers are opened by the contractor.

- (c) When the contractor is instructed or permitted to mix paints from stiff paint pastes, he shall proceed the follows :

Preparing a pot of paint – Take sufficient stiff paint from the cask or tin, and cover what is left in the cask or tin with a layer of water. Place it in a clean paint pot with linseed oil (raw, boiled, or pale boiled, as the case may be) and mix up with a stick, then add the other ingredients. Then (When a colour is desired) add the necessary stainer or pigment and mix up again thoroughly. Then take a second clean paint pot, cover it with canvas tied on tightly and work the mixed paint through this canvas, with a brush, into this second paint pot. Take off the canvas cover and the paint is then ready for use, except when a flat finish is desired for the final coat, when a little more turpentine may be added.

- (d) Specifications for oil paste laid in I.S. 86 to IS 100 shall also apply
- (e) Specifications for linseed oil laid in I.S. 75 , IS 77 and IS 78 shall also apply.
- (f) Specifications for turpentine laid in IS 533 shall apply.

2. Preparing the surface for painting - (i) For new wood work – Specifications for painting new wood work laid down in IS 2338 (Part I) shall apply (Particularly ref. Para . 6)

- (ii) For old wood work – Specifications for “Maintenance Painting “ laid down in IS 2338 (Part II) shall apply. (Particularly ref. para 4.2. and Table 3)

If the old painted surface is blistered or flaked, it will be necessary to completely remove the old paint, before repainting.

Place
Date

Signature of the Bidder
(NAME & ADDRESS WITH SEAL)



BHARAT HEAVY ELECTRICALS LIMITED

POWER PLANT PIPING UNIT

THIRUMAYAM- 622 507

CONTRACTS DEPARTMENT

Phone : 04333279551

E.mail : ilango@bheltry.co.in Website : www.bhel.com

Tender No:PPPU:WC:14:015

Tender Notice

Dt. 04.10.2014

This will be specified in the tender notice, and separate schedule rate provided, unless the painting item expressly states that the rate to be quoted shall be inclusive of removing old paint.

Old paint shall be removed in the manner specified in the tender notice. When no specification for method of removals mentioned in the tender notice, it shall be removed by burning with an ordinary painters ' blow – lamp, or by covering with kerosene oil or other paint remover and then burning ; afterwards scrapping off the paint. It can also be removed by applying solution composed of

Soft soap	½ part
Potash	1 part
Quicklime	½ to 1/3 part

The soap and potash are to be first dissolved by boiling in water. The lime is then added and the whole applied hot covering the paint, which will be removed with the solution. The solution must be left on for 12 to 34 hours after which the paint may be removed by washing with hot water.

Another method is as follows : The solution with the ingredients noted below should be mixed in the proportion given against each and stirred until the bubbling ceases – appalakaram 700 grams, washing soda 700 gm, slaked shell lime 1/70 cubic metre and sufficient water to make it into liquid form to flow freely.

The surface from which the paint is to be removed should be coated thickly using a whitewash brush and the solution left on for about 3 hours or so. The surface should then be washed first with water using sand and a coconut husk brush and afterwards washed clean with a good washing soap and water, using a boot brush. The surface should be allowed to completely dry up before repainting.

When the old paint has been thoroughly removed, the surface shall be washed, rubbed, down, and holes, etc., stopped, as specified above for new wood work, If the solvent for removal contains alkali a weak acid such a dilute vinegar should be used in washing down to neutralize the alkali. Care must be taken that the wood is not burnt in spots if a blow lamp is used. All greasy places shall be brushed over with turpentine, and then washed with soap and water.

(iii) For new iron and steel work – Specifications for painting new iron and steel work laid down in IS 1477 Part I shall apply.

(iv) For old painted surface, iron and steel work – Specifications for "maintenance painting ' for steel work laid down in IS 1477 Part I shall apply.

(v) For plastered surface – Specifications for painting on plastered surface laid down in IS 2395 Part I/ and Part II shall apply.

2. Application – No paint shall be applied until the articles have been passed for painting by the Public Works Department Officer in immediate charge of the work.

Place
Date

Signature of the Bidder
(NAME & ADDRESS WITH SEAL)



BHARAT HEAVY ELECTRICALS LIMITED

POWER PLANT PIPING UNIT

THIRUMAYAM- 622 507

CONTRACTS DEPARTMENT

Phone : 04333279551

E.mail : ilango@bheltry.co.in Website : www.bhel.com

Tender No:PPPU:WC:14:015

Tender Notice

Dt. 04.10.2014

The paint shall be laid on evenly and properly by means of crossing and laying off, the latter in the direction of the grain for wood work and care shall be taken that the paint is of such consistency that it runs easily from the brush. The paint must not be allowed to settle in the cans : to prevent this, each painter shall have in his paint can a small smooth stick, with which the paint shall be stirred occasionally. If a skin has formed on the top of the pain, it shall be carefully removed before the paint is used. To prevent mixed paints from drying of skinning over, they should be kept constantly covered with a think film of water. The paint shall not be stirred with the painting brush.

Specifications laid down in Is 1477 Part II shall also apply (Particularly ref. Appendix A)

No hair marks from the brush or clogging of paint shall be left on the work or puddles in the corners of panels, angles of mouldings, etc.,

In painting (or varnishing) doors and windows, the putty round the glass shall also be painted (or varnished, as the case may be) but the glass must not be smeared. Stains of paint in glass panes, etc., shall be carefully removed by applying a little turpentine and the whole work left in a clean condition.

4. General For painting, varnishing, wood – oiling etc., All painting and varnishing shall be neatly and carefully finished. Any damage done by dropping or smearing paint or varnish shall be made good by the contractor at his own cost. Superfluous patches or stains of paint or varnish shall be removed by means of turpentine.

Method of measurement laid down in IS . 1200 Part XV shall apply.

5. Rate – The contract rate for painting per 10 sqm shall include the cost of paint, preparing surface to be painted, brushes, cleaning materials and labour, the whole complete in accordance with this specification for the number of coats specified (including scaffolding, etc. Vide General conditions or contract) Unless other method of payment is specified or defined in the relevant schedule item

SPECIFICATION NO. 66-A

PAINTING PRIMING COAT ON WOOD, IRON OR PLASTERED SURFACES

1. Materials

1.1.The priming coat for wood work, iron work or plastered surface shall be as specified in the description of the item.

1.2.The priming coat shall be prepared at the site of work, or ready made primer of approved brand and manufacture shall be used.

1.3.Where primer for wood work is to be mixed at site, it shall be prepared from a mixture of red lead, white lead and double boiled linseed oil in the ratio of 0.7 kg : 0.7 kg = 1 litre.

Place
Date

Signature of the Bidder
(NAME &ADDRESS WITH SEAL)



BHARAT HEAVY ELECTRICALS LIMITED

POWER PLANT PIPING UNIT

THIRUMAYAM- 622 507

CONTRACTS DEPARTMENT

Phone : 04333279551

E.mail : ilango@bheltry.co.in Website : www.bhel.com

Tender No:PPPU:WC:14:015

Tender Notice

Dt. 04.10.2014

1.4. Where primer for steel work is to be mixed at site, it shall be prepared from a mixture of red lead, raw linseed oil and turpentine in the ratio of 2.8 kg : 1 litre

1.5. The specifications for the base material and thinner for mixed on site primers shall be as follows :

- (a) White lead : The white lead shall be pure and free from adulterants like barium sulphate and whiting. It shall conform to IS : 103 as amended from time to time.
- (b) Red lead : This shall be in powder form and shall be pure and free from adulterants like brick dust etc. it shall conform to IS : 103 as amended from time to time.
- (c) Red linseed oil – Raw linseed oil shall be lightly viscous 5 but clear and of yellowish colour with light brown tinge. Its specific gravity at a temperature of 30° C shall be between 0.923 and 0.928. the oil shall be mellow and sweet to the tests with very little smell. The oil shall be of sufficiently matured quality. Oil, turbid or thick, with acid and bitter taste and rancid odour and which remains sticky for a considerable time shall be rejected. The oil shall conform in all respects to IS : 75 as amended from time to time. The oil shall be of approved brand manufacture.
- (d) Double boiled linseed oil – This shall be more viscous than the raw oil, have a deeper colour and specific gravity between 0.931 and 0.945 at a temperature of 30° C. It shall dry with a glossy surface. It shall conform in all respects to IS : 77 as amended from time to time. The oil shall be of approved brand and manufacture
- (e) Turpentine – Mineral turpentine i.e., petroleum distillate which has the same rate of evaporation as vegetable turpentine (distillate product of Oleoresin of Conifers) shall be used. It shall have no grease or other residue when allowed to evaporate. It shall conform to IS : 83 as amended from time to time.

1.6. All the above materials shall be of approved manufacture and brought to site in their original packings in sealed condition.

2. Preparation of surface

2.1. Wood work : The wood work to be painted shall be dry and free from moisture.

The surface shall be thoroughly cleaned. All unevenness shall be rubbed down smooth with sand paper and shall be well dusted. Knots, if any shall be covered with preparation of red lead made by grinding red lead in oil mixing with strong glue size and used hot.

The surface treated for knotting shall be dry before painting is applied. After the priming coat is applied, the holes and indentation on the surface shall be stopped with glazier's putty or wood putty (for specifications for glazier's putty and wood putty see sub-paras 9'33 and 13.37.1'2 CPWD specification respectively) . Stopping shall not be done before the priming coat is applied as the wood will absorb the oil in the stopping and the later is therefore liable to crack.

2.2. Iron and steel work – all rust and scales shall be removed by scraping or by brushing with steel wire brushes. Hard skin of oxide formed on the surface of wrought iron during rolling which becomes loose by rusting , shall be removed

Place
Date

Signature of the Bidder
(NAME & ADDRESS WITH SEAL)



BHARAT HEAVY ELECTRICALS LIMITED

POWER PLANT PIPING UNIT

THIRUMAYAM- 622 507

CONTRACTS DEPARTMENT

Phone : 04333279551

E.mail : ilango@bheltry.co.in Website : www.bhel.com

Tender No:PPPU:WC:14:015

Tender Notice

Dt. 04.10.2014

All dust and dirt shall be thoroughly wiped away from the surface.

If the surface is wet, it shall be dried before priming coat is undertaken.

- 2.3. Plastered surface – The surface shall ordinarily not be painted until it has dried completely. Trial patches of primer shall be laid at intervals and where drying is satisfactory, painting shall be taken in hand. Before primer is applied, holes and undulations, shall be filled up with plaster paris and rubbed smooth.
3. Application – The primer shall be applied with brushes, worked well into the surface and spread even and smooth. The painting shall be done by crossing and laying off.
4. Other details – The specification for “Painting (General)” shall hold good so far as they are applicable.

SPECIFICATION NO. 66-B

PAINTING WITH SUPERIOR QUALITY READY MIXED PAINT OVER G.I. SHEET

1. Paints – superior quality ready mixed paint, suitable in painting over G.I. sheets, of approved brand and manufacture and of the required shade shall be used.
2. Preparation of surface
 - 2.1. New work – (a) The painting of new G.I. sheets shall not usually be done till the sheets have weathered for about a year. When new sheets are to be painted before they have weathered, they shall be treated with a mordant solution prepared by mixing 38 gm. of copper acetate in a litre of soft water or 13 gm. hydrochloric acid in a solution of 13 gm. each of copper chloride, copper nitrate and ammonium chloride dissolve in a litre soft water. This quantity of solution is sufficient for about 235 to 280 sqm. of area and is applied for ensuring proper adhesion of paint. The painting with the mordant solution will be paid for separately.
 - (b) Before painting weathered G.I. sheets, rust patches shall be completely cleaned with coarse emery paper and brush. All grease marks also shall be removed and the surface washed and dried. And rushed surface shall be touched with red mixed paint of red lead.
 - 2.2. Old work – (a) IF the old paint is firm and sound, it shall be cleaned of grease, smoke, etc., The surface shall then be rubbed down with sand paper and dusted. Rusty patches shall be cleaned up and touched with red lead.
 - (b) If the old paint is blistered and flaked, it shall be completely removed. Such removal shall be paid for separately and painting shall be treated as on new work.
3. Application – The number of coats to applied shall be as in the description of item. In the case of C.G.I.. sheets, the crown of the corrugations shall be painted first and when these get dried the general coat shall be given to ensure uniform finish over the entire surface without the crowns showing signs of thinning.

The second or additional coats shall be applied when the previous coat has dried

Other details – The specifications for “Painting (General)” shall hold good so far as they are applicable.

SPECIFICATION NO. 66 – C

Place
Date

Signature of the Bidder
(NAME & ADDRESS WITH SEAL)



BHARAT HEAVY ELECTRICALS LIMITED

POWER PLANT PIPING UNIT

THIRUMAYAM- 622 507

CONTRACTS DEPARTMENT

Phone : 04333279551

E.mail : ilango@bheltry.co.in Website : www.bhel.com

Tender No:PPPU:WC:14:015

Tender Notice

Dt. 04.10.2014

SPRAY PAINTING WITH FLAT WALL PAINT ON NEW WORK INCLUDING PRIMING COAT

1. Materials – The priming coat shall consist of “Distemping primer” or “Cement primer” as specified in the description of the item. They shall be approved brand and manufacture. The flat wall paint shall be of approved brand and manufacture and of the required shade.

2. Preparation of the surface for priming coat – The surface shall be thoroughly cleaned of dust, old white or colour wash by washing scrubbing. The surface shall then be allowed to dry for atleast 48 hours. It shall then be sand papered to give a smooth and even surface. Any unevenness shall be made good by applying putty, made of plaster of paris, mixed with water on the entire surface including filling up the undulations and then sand papering the same after it is dry.

3. Application

3.1. Primer Coat – The specified primer shall be painted or sprayed over the surface in an even and uniform layer

Note : Flat wall paint shall normally be applied on walls 12 months after their completion, in which case, Distemper primer will suffice. If the walls are to be painted earlier, the primer coat shall consist of cement primer.

3.2. Painting Coat – When the surface is dry, the spray painting with the wall paint in uniform and even layers will be done to the required number of coats. Each coat shall be allowed to dry over night and lightly rubbed with very fine grade of sand paper and loose particles brushed off before the next coat is sprayed.

If after the final coat of wall paints, the surface obtained is not upto the mark, further one or more coats as required shall be given after rubbing down the surface and dusting off all the loose particles to obtain a smooth and even finish.

If the primer or wall paint gets thickened during the application, it shall be thinned suitably with the thinner recommended by the manufacturer. Adequate ventilation shall be provided to disperse spray fumes. Fittings and floor shall be protected from the spray.

Other details – The specifications for “painting (general) “ shall hold good as far as applicable.

SPECIFICATION NO. 66 – D

1. Paint – The specification shall be same as in paragraph 12.28.1.
2. General – Where the old paint is in sound condition, renewal shall be carried out as given in para 3 to 5. Otherwise the old paint shall be completely stripped and spray painting shall be carried out as over new work. Such removal shall be paid for separately.
3. Preparation of surface – The surface shall be washed to remove dust and dirt. A mild detergent solution like soap water shall be used for washing and the surface shall also be rubbed down

Place
Date

Signature of the Bidder
(NAME & ADDRESS WITH SEAL)



BHARAT HEAVY ELECTRICALS LIMITED

POWER PLANT PIPING UNIT

THIRUMAYAM- 622 507

CONTRACTS DEPARTMENT

Phone : 04333279551

E.mail : ilango@bheltry.co.in Website : www.bhel.com

Tender No:PPPU:WC:14:015

Tender Notice

Dt. 04.10.2014

lightly with abrasive paper when dry. Any patches appearing on the surface shall first be touched up with a coat of paint. These shall be allowed to dry and then rubbed down lightly.

4. Painting – The paint shall then be applied with spraying machine in uniform and even layer. A second coat shall be applied if considered necessary by the Engineer – in – charge but only after the first coat is complete and dry hard.
5. Other details – The specifications for “Painting (General) “ shall hold good as far as they are applicable.

SPECIFICATION NO. 66 – E

PAINTING WITH ACID PROOF PAINT

1. Paint – Acid proof paint of approved brand and manufacture and of the required shade shall be used.
2. Preparation of surface and application – The specifications shall be same as for “Painting with ordinary or superior quality ready mixed paints on new work or old work”
3. Other details – The specifications for “Painting (General)” Shall hold good as far as they are applicable.

SPECIFICATION NO. 66 – F

PAINTING CAST IRON RAIN WATER, SOIL WASTE AND VENT PIPES AND FITTINGS

1. Painting cast iron rain water, soil, waste and vent pipes and fittings including priming coat, on new work.
- 1.1. Paints – (a) Primer – The primer shall be prepared on site or shall be approved brand and manufacture as specified in the item.

Place
Date

Signature of the Bidder
(NAME & ADDRESS WITH SEAL)



BHARAT HEAVY ELECTRICALS LIMITED

POWER PLANT PIPING UNIT

THIRUMAYAM- 622 507

CONTRACTS DEPARTMENT

Phone : 04333279551

E.mail : ilango@bheltry.co.in Website : www.bhel.com

Tender No:PPPU:WC:14:015

Tender Notice

Dt. 04.10.2014

RAILWAY SIDING WORKS

RECOMMENDED DIMENSION

Minimum distance center to center of track	4725 mm
Minimum width in embankment (single line)	6100 mm
Minimum width in cutting (excluding side drains)	5490 mm

SLEEPER REQUIREMENT FOR TURNOUT B G

SIZE OF SLEEPER	1 IN 8.5	
	Total	Sl.No.
9' x 10" x 6"	6	1, 3 to 7
9' x 12" x 6"	1	2
10' x 10" x 6"	12	8 to 19
11' x 10" x 6"	8	20 to 27
12' x 10" x 6"	6	28 to 33
13' x 10" x 6"	3	34 to 36
14' x 10" x 6"	4	37 to 40
14' x 12" x 6"	2	41 to 42
15' x 12" x 6"	3	43 to 45
16' x 12" x 6"	3	46 to 48
16' x 10" x 6"	3	49 to 51

SAFETY OF TRACK

1) The permanent way Inspector is directly responsible for the safety of the track. He shall be vigilant to locate faults in the permanent way and promptly remedy them.

Track defects which are beyond his powers to remedy should be immediately brought to the Assistant Engineer's Notice by the permanent way Inspector and mention of the same made in the specialreports on the condition of permanent way on the section.

Place
Date

Signature of the Bidder
(NAME & ADDRESS WITH SEAL)



BHARAT HEAVY ELECTRICALS LIMITED

POWER PLANT PIPING UNIT

THIRUMAYAM- 622 507

CONTRACTS DEPARTMENT

Phone : 04333279551

E.mail : ilango@bheltry.co.in Website : www.bhel.com

Tender No:PPPU:WC:14:015

Tender Notice

Dt. 04.10.2014

2) Independent of detailed periodical inspections, the permanent way Inspector, during his routine inspections, should watch for any signs of weakness in bridges and structures affecting track and promptly report any matter demanding the Assistant Engineer's attention.

3) Trees in proximity to and liable to foul the track during a storm should be felled

Station yards : The Permanent way Inspector shall ensure cleanliness of station yards Under-growth should be cleared every year, usually in the month of August, before the seed has ripened.

At stations where it is proposed to stack engineering 'or' Contractor's materials, the stacking area should be carefully selected and clearly demarcated. The materials should be stacked methodically in a tidy manner.

Duties of Permanent Way Mistries:

General responsibility : They are normally in -charge of items of works which requires a higher level of supervision that can be exercised by gang Mate. They will carry out the following specific works, 'or' such other works pertaining to track maintenance, as may be allotted to them by the Permanent way Inspector.

- (i) Attention to bad spots.
- (ii) Directed track maintenance
- (iii) Isolated renewal of sleepers.
- (iv) Lubrication of rail joints.
- (v) carrying out of materials, if issued with competency certificates. They will be responsible for ensuring safety for the works being supervised by them.

Knowledge of rules and signals : for mistries, mates, key man & gang men.

Every permanent way mistry shall have a correct knowledge of hand signals and shall be conversant with the following rules:-

- 1) Protecting line in an emergency and during work affected track.
- 2) action to be taken when train is noticed have parted.
- 3) "safety first" rules
- 4) Action to be taken when sabotage is suspected.
- 5) Patrolling in emergencies.

Whenever permanent way mistries and in-charge of gangs/units, they will carry out all the duties and responsibilities assigned to the mate.

Place
Date

Signature of the Bidder
(NAME & ADDRESS WITH SEAL)



BHARAT HEAVY ELECTRICALS LIMITED

POWER PLANT PIPING UNIT

THIRUMAYAM- 622 507

CONTRACTS DEPARTMENT

Phone : 04333279551

E.mail : ilango@bheltry.co.in Website : www.bhel.com

Tender No:PPPU:WC:14:015

Tender Notice

Dt. 04.10.2014

Safety of the line : Every Mate shall see that his length of line is kept safe for the passage of trains. Kilometerage needing urgent attention shall be picked up without waiting for orders from the Permanent way Inspectors.

Observance of sleeper packing during passage of train by musters and gang charts

During the passage of the first and last trains in working hours, the Mate and his men should stand on the cess, each about one rail length apart, and observe the effect on the sleepers; loose sleepers, should then be marked and adequately packed. On double line, the gangs shall invariably stand on the cess side and not in between the tracks.

Tidiness of section :

while breaking the work for mid day meals the mate should see that the tools are kept away from track. The mate shall see that the whole of his gang length is kept neat and tidy and that all loose materials are collected and brought to stations, gangs quarters 'or' gate lodges

Action when line is unsafe 'or' in the event of Accident :

(1) If a mate 'or' his key man considers that the line is likely to be rendered unsafe 'or' that any train is likely to be endangered in consequence of any defect in the permanent way 'or' works, 'or' abnormal rain 'or' flood or any other occurrence, he shall take immediate steps to secure the safety of trains by using the prescribed signals to " proceed with caution " 'or' to stop as necessity may require, as soon as possible, report the circumstances to the traffic office and the permanent way Inspector.

(2) In the event of an accident, the mate, key men and gang men should looked for broken fittings of wagons and track components and see that these are not distributed until they have been seen and recorded by a responsible official.

Patrolling during abnormal rainfall :

During abnormal rainfall, the Mate should organise patrolling on the gang length, whether 'or' not patrolmen are on duty. In the event of damage being detected, action should be taken to safe guard traffic by protecting the line.

Inspection of Rails in service

General : Rails should be inspected for flaws specially, when the rails show signs of fatigue and the rail wear is excessive. The detection of rail flaws is done either by visual examination of the rail 'or' by ultrasonic rail flaw detection.

Rail failures :

Place
Date

Signature of the Bidder
(NAME & ADDRESS WITH SEAL)



BHARAT HEAVY ELECTRICALS LIMITED

POWER PLANT PIPING UNIT

THIRUMAYAM- 622 507

CONTRACTS DEPARTMENT

Phone : 04333279551

E.mail : ilango@bheltry.co.in Website : www.bhel.com

Tender No:PPPU:WC:14:015

Tender Notice

Dt. 04.10.2014

Definition of a Rail failure : A rail is said to have failed if it has fractured in track 'or' it is considered necessary to remove it from track on account of defects other than those due to accidental damages due to buckling, kinking, derailments,, abnormal wheel burns etc.

Careful usage of fish plates :

The hammering of the fish plates should be strictly forbidden. For removing a fish plate which has seized to the rails, the fish plate may be tamped gently, by a hammer by interposing a wooden a piece.

Over tightening of fish plates should be avoided. Fish bolt spanner of standard length 680 mm to 760 mm on BG shall be used. Alternatively mechanical torque wrenches with predetermined torque should be used. When tightening bolts the two central bolts should be tightened first.

Ballast and ballast Depots :

Type of ballast in use : Store ballast should be used on all running lines, including points and crossings. Other types of inferior ballast such as muram, sand, shingle etc. may be used on sidings, yards, non-running lines and sub-ballast

Size of the ballast:

The gauge of store ballast shall be as follows :-

With all types of sleepers 50 mm gauge on square mesh sieve under points and crossings 40 mm gauge on square mesh sieve.

Minimum depths of ballast cushion :

(a) The recommended minimum depth of the ballast below the bottoms of the sleepers at the rail seat should be as under

<u>Group</u>	<u>Recommended depth</u>
BG Group E	150 mm

(b) Increase in ballast cushion to make up the recommended depth will be carried out during complete track renewal, through sleeper renewal 'or' programmed deep screening.

ACTION DURING ACCIDENTS INCLUDING BREACHES AND PRE- MONSOON PRECAUTIONARY MEASURES

OBSERVANCE OF RULES:-

1. Any occurrence which does or may affect the safety of the railway, its engines, rolling stock permanent way, works, passengers or servants which affects the safety of others or which does or may cause delays to trains or loss to the railway, is termed an accident

Place
Date

Signature of the Bidder
(NAME & ADDRESS WITH SEAL)



BHARAT HEAVY ELECTRICALS LIMITED

POWER PLANT PIPING UNIT

THIRUMAYAM- 622 507

CONTRACTS DEPARTMENT

Phone : 04333279551

E.mail : ilango@bheltry.co.in Website : www.bhel.com

Tender No:PPPU:WC:14:015

Tender Notice

Dt. 04.10.2014

Occurrence out side the railway limits threatening safety of the line or trains should also be reported as accidents .For instance a flood outside railway limits may seriously threaten the safety of the line should be treated as an accident.

General Rules :-

A) Every railway servant shall

1. see that every exertion is made for ensuring safety of the public
2. promptly report to his superior any occurrence affecting the safe or proper working of the railway which may come to his notice.
3. Render on demand all possible assistance in the case of an accident ' or' obstruction.

B) Every railway servant who observes

1. Any obstruction, failure ,or threatened failure of any part of the way or works
2. any thing wrong with a train, or
3. any unusual circumstances likely to interfere with the safe running of trains or the safety of the Public.

Shall take immediate steps, such as the circumstances of the case may demand to prevent accident, and where necessary, inform to Traffic Office / Section Engineer/PWI by the quickest possible means.

SPECIAL CONDITIONS AND SAFETY PRECAUTIONS TO BE TAKEN AT WORK SITES.

1. No lorry or road vehicles shall be operated so as to affect the safety of trains. They should be allowed to work well outside the moving dimension. At each of the locations, official should be posted as in charge to ensure that lorries do not infringe the schedule moving dimension any time and protect the track in case of emergency. The facilities the driver to whistle, a whistle-board will have to be provided at the appropriate place.

2. All vulnerable locations where constructions activity is in progress adjacent to existing railway lines, should be off with proper barricades. The most vulnerable locations shall be barricaded with rail barricades projecting atleast 1 M above ground. At all other locations barricades of not less than 1.5 M height, consisting of bamboo / casuarina poles and supported horizontally by similar bamboo / casuarina poles should be provided.

3. All the barricades are to be painted stuck on with luminous paints stripes at suitable intervals on the barricades.

4. The entry to new bags which run alongside the existing track should be protected by barriers which can be closed and opened wherever necessary.

Place
Date

Signature of the Bidder
(NAME & ADDRESS WITH SEAL)



BHARAT HEAVY ELECTRICALS LIMITED

POWER PLANT PIPING UNIT

THIRUMAYAM- 622 507

CONTRACTS DEPARTMENT

Phone : 04333279551

E.mail : ilango@bheltry.co.in Website : www.bhel.com

Tender No:PPPU:WC:14:015

Tender Notice

Dt. 04.10.2014

5. At locations which are not vulnerable, provision of barricades can also be with (i) 0.6 m and 0.3m deep trenches or (ii) stones of minimum size 30cm x 15cm at 1M intervals and projecting 0.3M above ground level and painted white. Trenches should be allowed only in these locations where they do not lead to subsidence to Railway track as may be processed by the Section Engineer/ P. way.

6. Barriers shall also be provided in the case of double lines, particularly at all existing LC where there is every possibility of road vehicles entering the finished formation. These barriers are to be opened only for the movement of railway contractor's authorised vehicles of other Railway vehicles.

7. Road vehicles employed by the contractor or should have the certificate for the road worthiness and each vehicle numbered and the license particulars maintained contractors should ensure that the drivers permitted by them to work such road vehicles are identified, counseled, certified and are provided with photo identity card.

8. Wherever the work repairs the movement of the road vehicles with in a distance of 3.5 m to 6.0 m from the centre line of the nearest track, such work shall be done only in the presence of railway employee authorised by the engineer-in-charge. No part of road vehicles will be allowed at less than 3.5 m from track centre Cost of such railway employees shall be borne by the railways.

9. The driver of the vehicles shall always face the track when reversing the vehicles and wherever cannot face the track for whatever reason shall be invariably be assisted by a helper with a whistle who should guide him and ensure safety.

10. All work sites shall be supervised by the contractors represented as also a representative of the railway organisation whatever work of plying road vehicles within 6.0 m zone is actual in progress; look out men should invariably to available. Look out men will have to be provided by the contractor from out of the list of persons who are authorised to carry out these duties. Authorization will be issued to the individuals by the representative of the engineer-in-charge. One supervisor who shall be permanent staff (Gang man) leaned to JE/W/CN from the respective gangs in whose beat the work is in progress (to be spared by the respective P.way Engineer / Open line) will monitor the availability and alertness of the lookout men. In case of non -availability of look out men the railway supervisor shall stop further activities for plying of road vehicles. Even if no work is executed the night lookout men shall patrol the best identified to ensure the safety of running trains, especially from any infringement.

11. The supervisor mentioned in Para 10 above should be trained in protection rules and supplied with minimum equipment required for protecting the track. Such staff should also be provided with basic communication facility a walkie-talkie with communication facility the nearest station master or adjacent site so as to communicate to the nearest station in case of emergency / un usual occurrence till it is made available the supervisor shall use the nearest LC gate/telephone or other means of communication to relate the incident most speedily.

Place
Date

Signature of the Bidder
(NAME & ADDRESS WITH SEAL)



BHARAT HEAVY ELECTRICALS LIMITED

POWER PLANT PIPING UNIT

THIRUMAYAM- 622 507

CONTRACTS DEPARTMENT

Phone : 04333279551

E.mail : ilango@bheltry.co.in Website : www.bhel.com

Tender No:PPPU:WC:14:015

Tender Notice

Dt. 04.10.2014

12. Representative of Engineer-in-charge of the constructions organised will responsible for the general supervisors at each site.

13. Working along side the track during the night hours is normally prohibited. Such work can be done in the night only with the written permission of the Engineer-in-charge of the construction activity were night work is permitted lighting of the work as required should be done.

14. The contractor shall be fully responsible for ensuring safety at all time and shall bear the cost of all damages incase of accidents/unusual occurrences damages to Railway property and its passengers.

The contractor should engage Technical persons and Workmen with the following qualifications for works as detailed below and the contractor shall carry out the Health Performance check at his cost for the workman engaged in the work through a registered medical practitioner and produce the certificate on demand.

CHECK FOR HEALTH PERFORMANCE

Sl. No.	Activity	Hazard	Exposure Consequence	Check for	Periodicity
1	Concrete Dismantling	Emission of Dust & Noise	1	Lung function	Once in a Year
2	Concrete Mixing	Emission of Dust & Noise	1	Lung function	Once in a Year
3	Painting	Emission of Dust & fumes	1	Lung & throat function	Once in a Year
4	Cutting & Welding	Emission of fumes and gas. Exposure to Live wire	3	Eyes & Lung function	Once in a Year
5	Working on AC sheets	Emission of Dust	3	Lung function	Once in a Year
6	Sweeping of Roads	Emission of Dust	2	Lung function	Once in a Year
7	Collection and disposal of Sanitary waste	Foul smell & susceptibility to decease.	3	Lung function and skin irritation	Once in a Year
8	Handling of Oxygen & Acetylene Cylinders	Leakage of gas	4	Throat irritation	Once in a Year
9	Cleaning of Manholes	Exposure to poisonous gas	4	Suffocation	Once in a Year
10	Cleaning of Overhead tank	Emission of Dust	1	Suffocation & skin irritation	Once in a Year

Place
Date

Signature of the Bidder
(NAME & ADDRESS WITH SEAL)



BHARAT HEAVY ELECTRICALS LIMITED

POWER PLANT PIPING UNIT

THIRUMAYAM- 622 507

CONTRACTS DEPARTMENT

Phone : 04333279551

E.mail : ilango@bheltry.co.in Website : www.bhel.com

Tender No:PPPU:WC:14:015

Tender Notice

Dt. 04.10.2014

NOTE: Exposure Consequence

1. Slightly harmful
2. Harmful
3. Very harmful
4. Extremely harmful

SCHEDULE 'A' - (Bill Of Quantities) ATTACHED IN THE PRICE BID

SCHEDULE 'B'

1. The following materials will be issued FREE of cost to contractor at PPPU BHEL/ Thirumayam.

Sl.No.	DESCRIPTION
1	Cement.
2	M.S Rounds, C.T.D Bars & Structural Steel, rails and all railway materials.
3	A.C. / Al Zn Alloy Coated HT steel sheets / Polycarbonate Sheets.
4	Cast iron pipes & specials including pig lead for jointing.

2. It will be the responsibility of the Contractor to submit his demands for the above stores in writing atleast seven days in advance of the actual requirement.
3. Issue of Stores is subject of the availability at the place of issue cited above, items of stores to be issued by BHEL which are not available at the time of indenting by the contractor may be supplied by BHEL after necessary procurement. The contractor shall not be entitled to any claim of compensation for delay in the supply of stores by BHEL under any circumstances.
4. The materials will be issued only during the working hours of the BHEL Stores Department (8.00 a.m. to 4.30 p.m.). Contractor shall have to transport them to the site of work at his own cost as soon as they are issued to him.
5. The steel materials if issued will be in random lengths and sizes as stocked by the BHEL and the cost of all cutting, conversion, substitution and fabrication as well as wastage shall have to be borne by the Contractor.
6. The contractor shall from time to time render proper account of all materials issued to him by BHEL. If he fails to do so, no further issue of materials will be made to him and he will be held responsible for any delay in the execution of the work which may occur on this account.

Place
Date

Signature of the Bidder
(NAME & ADDRESS WITH SEAL)



BHARAT HEAVY ELECTRICALS LIMITED

POWER PLANT PIPING UNIT

THIRUMAYAM- 622 507

CONTRACTS DEPARTMENT

Phone : 04333279551

E.mail : ilango@bheltry.co.in Website : www.bhel.com

Tender No:PPPU:WC:14:015

Tender Notice

Dt. 04.10.2014

7. Where A.C. Sheets and accessories, Doors, Windows, Sanitary fittings, Special glasses or other items are issued free of cost to the contractor, the contractor will have to make good at his own cost any loss or damage to any part or whole of the items issued to him as above. All wastage within the premises limits as fixed by BHEL will be charged for at the prescribed issued rates of BHEL. Excess wastage will be charged for at punitive rates which will be 100% higher than the issue rates.
8. All surplus materials in good condition which are not returned to the BHEL Stores as also quantities of materials consumed in excess of the max. permissible limit as fixed by BHEL shall be charged for at punitive rates.

The decision of the Senior Engineer / Dy. Manager / Manager as to the extent to which materials have been rendered surplus or consumed in excess of the actual requirements shall be final and conclusive and binding on the contractor.

SCHEDULE 'C' ISSUE OF TOOLS AND PLANTS TO CONTRACTORS

Sl.No.	Qty.	Particulars	Details of Hire BHEL Crew Supplied	Charges Per unit Per Day	Place of Issue	Remarks
--------	------	-------------	------------------------------------	--------------------------	----------------	---------

.....Nil.....

- a. Machineries shall not be operated over time without the written permission of the Sr. Engineer / Dy. Manager / Manager.
- b. All Coolies, Watermen etc., required in addition to BHEL crew mentioned in column 4 above shall be arranged by the contractor at his own expense.

SCHEDULE 'D'

NOTE : All Drawings are to be signed by the Contractor as well as the officer entering into contract.

SL.No.	DRAWING NUMBER	DESCRIPTION
	MS:TRM:40:225:1118D	Layout Drawing

The under mentioned records / log-books / registers (whichever is applicable) shall be maintained.

1. Hindrance Register
2. Site Order Book

Place
Date

Signature of the Bidder
(NAME & ADDRESS WITH SEAL)



BHARAT HEAVY ELECTRICALS LIMITED

POWER PLANT PIPING UNIT

THIRUMAYAM- 622 507

CONTRACTS DEPARTMENT

Phone : 04333279551

E.mail : ilango@bheltry.co.in Website : www.bhel.com

Tender No:PPPU:WC:14:015

Tender Notice

Dt. 04.10.2014

3. Test Check of measurements
4. Cement and other free issue materials supply and consumption daily register
5. Approved Field Quality Plans (FQP) of various works
6. Records of test reports of field tests
7. Records of manufacturer's test certificates
8. Record of disposal of scraps generated during and after the work completion.

CERTIFICATE OF COMPLIANCE

To

Senior Manager / Contracts
Power Plant Piping Unit,
BHEL – Thirumayam-622 507.

Sir,

We have carefully read the tender specifications connected with the above tender and have understood the technical requirements and conditions to the above tender which consists of

1. General Details about vendor,
2. Pre-Qualification Criteria,
3. Work specific Terms & Conditions,
4. Commercial Terms & Conditions,
5. Conditions related to the Welfare of labour,
6. General Terms and Conditions,
7. Terms & Conditions related to Safety,
8. General and Special Specifications,
9. Price Bid.

We agree to carry out the contract tendered at the rates as offered by us in the Price Bid (Rate Schedules) submitted by us and in accordance to the terms and conditions of the subject tender.

If the contract is awarded to us the prices shall be kept firm till the completion of contract.

Demand Draft of..... Bank bearing No.....dated.....for an amount of
₹ _____/- (Rupees _____ only) is submitted in a separate cover towards EMD.

Place
Date

Signature of the Bidder
(NAME & ADDRESS WITH SEAL)

To
THE PURCHASE/CONTRACT EXECUTING AGENCY/BHEL

ACCEPTANCE FOR ELECTRONIC FUND TRANSFER / RTGS TRANSFER

01	Name & Address of the Supplier / Sub-contractor	
02	VENDOR CODE assigned by BHEL	
Details of Bank Account:		
03	NAME & ADDRESS OF THE BANK	
04	NAME OF THE BRANCH	
05	BRANCH CODE	
06	MICR CODE	<input type="text"/> <input type="text"/> <input type="text"/> <input type="text"/> <input type="text"/> <input type="text"/> <input type="text"/> <input type="text"/> <input type="text"/> <input type="text"/> <input type="text"/>
07	ACCOUNT NUMBER	
08	TYPE OF ACCOUNT	CURRENT A/C / OD / CASH CREDIT
09	BENEFICIERY'S NAME	
10	IFSC CODE OF THE BRANCH	<input type="text"/> <input type="text"/> <input type="text"/> <input type="text"/> <input type="text"/> <input type="text"/> <input type="text"/> <input type="text"/> <input type="text"/> <input type="text"/> <input type="text"/>
11	EMAIL ID	
12	TELEPHONE/MOBILE NO.	

CERTIFICATE

I / We hereby agree to receive the payments due from BHARAT HEAVY ELECTRICALS LIMITED by the National Electronic Funds Transfer and/or RTGS Transfer mode by credit to my / our above mentioned Bank Account. I / We also agree that payments made to the above mentioned Account is a valid discharge of the liability of Bharat Heavy Electricals Limited. I / We also agree to bear the applicable Bank Charges for the above mode of transfer. **A copy of the cheque leaf/cancelled cheque leaf of the above account is sent herewith.**

AUTHORISED SIGNATORY WITH NAME SEAL

Banker's Certification

We confirm that we are enabled for receiving RTGS and NEFT credits and we _____ further confirm that the account number of _____ (name of account holder), the signature of the authorized signatory and the MICR and IFSC codes of our Branch mentioned above are correct.

PLACE:
DATE :

(Manager / Officer's)
Signature Under Bank stamp and Name Seal
With Membership No.
(Telephone / Mobile No. _____)

Forwarded to Accounts Dept.
We confirm the above details are verified with the records available with us. Signature of the BHEL Executive with Name Seal (Operating the Contract/Services)



BHARAT HEAVY ELECTRICALS LIMITED

POWER PLANT PIPING UNIT

THIRUMAYAM- 622 507

CONTRACTS DEPARTMENT

Phone : 04333279551

E.mail : ilango@bheltry.co.in

Website : www.bhel.com

Tender No:PPPU:WC:14:015

Tender Notice

Dt. 04.10.2014

PROPOSED RELOCATION OF 40T FURNACE IN BAY 5 / PPPU THIRUMAYAM

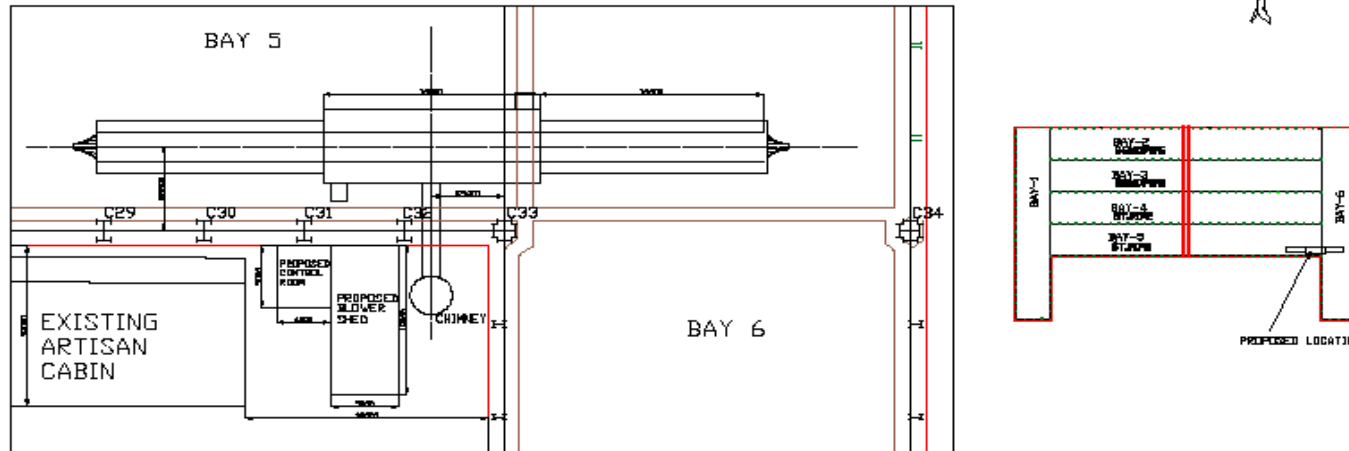

DRAFT PROPOSAL

NOTE:

1. MS layouts indicate location feasibility only. Any other clearance/approval required for legal/statutory, etc. compliances need to be taken separately.
2. The 40T furnace 1791-1534 to be shifted from Bay 1A / Bldg 1, HPBP (Vide Note _____)
3. If there is a cable trench between C33 and D33, it should be rerouted suitably.
4. * Proposed Coordinates

ALL DIMENSIONS ARE IN MM

Bharat Heavy Electricals Ltd. MANAGEMENT SERVICES WORK STUDY	
PREPARED	E.M.SANTHOSH/IE
CHECKED	M.TAMILNAMB/SM
SAFETY CLEARANCE	
APPROVED	P.BALAKUMAR/SDGM
DATE: 28/07/2014	SCALE: NTS
DRC No: MS/TRM:40:226:118D	

Place
Date

Signature of the Bidder
(NAME & ADDRESS WITH SEAL)



BHARAT HEAVY ELECTRICALS LIMITED

POWER PLANT PIPING UNIT

THIRUMAYAM- 622 507

CONTRACTS DEPARTMENT

Phone : 04333279551

E.mail : ilango@bheltry.co.in

Website : www.bhel.com

Tender No:PPPU:WC:14:015

Tender Notice

Dt. 04.10.2014

PRICE BID

FOR

“Construction of foundations for 40T furnace, chimney, blower and blower shed & control room at BHEL-PPPU, Thirumayam”

SCHEDULE – A

NAME OF WORK: Construction of foundations for 40T furnace, chimney, blower and blower shed & control room at BHEL-PPPU, Thirumayam”

Description of Work:

The scope of work includes civil work for 40T furnace in PPPU of BHEL, Thirumayam as per the rates quoted in the Bill of Quantities of Price Bid.

The brief description of items of works is given in the Bill of Quantities provided in the price bid.

The tenderer has to quote the rates both in figures and in words for all the items given in the Bill of Quantities provided in the price bid.

I / We _____ have read the condition of tender attached hereto and agree to abide by such conditions. I/We offer to execute the works in tender ref: **PPPU:WC:14:015** at the item rates quoted in the BOQ.

I / We further agree to sign an Agreement Bond to abide by the General Conditions of Contract and to carry out all works according to the specifications for materials and works of Bharat Heavy Electricals Limited, Thirumayam-622 507. In case of acceptance of the tender by BHEL, I/We bind myself/ourselves to execute the contract documents within 7 days after notice that my/our tender has been accepted and this contract has been awarded to me/us and thus failing which I/We shall have no objection to the forfeiture of the Earnest Money amount lodged with Bharat Heavy Electricals Limited, Thirumayam-622 507.

I / We further agree to include all tools & plants and consumables required for the work in my / our scope but required power and water will be provided at one point by BHEL at free of cost and based on this, we have quoted our item rates.

Place
Date

Signature of the Bidder
(NAME & ADDRESS WITH SEAL)

	BHARAT HEAVY ELECTRICALS LIMITED POWER PLANT PIPING UNIT THIRUMAYAM- 622 507 CONTRACTS DEPARTMENT
	Phone : 04333279551 E.mail : ilango@bheltry.co.in Website : www.bhel.com

Tender No:PPPU:WC:14:015

Tender Notice

Dt. 04.10.2014

SCHEDULE - A
BILL OF QUANTITIES

NAME OF WORK:- Construction of Foundations for 40T Furnace, Chimney, Blower and Blower Shed & Control room at PPPU (BHEL), Thirumayam

Rates quoted shall be exclusive of Service Tax.

SL No	QTY	UNIT	DESCRIPTION OF WORK	RATE-₹ (IN FIG.)	RATE-₹ (IN WORDS)	AMOUNT (₹)
1	12	CUM	Dismantling / removing / demolishing as the case may be of the following by manually/mechanical means and carefully stacking the serviceable materials at site of work or conveying and handing over the same at BHEL stores and disposal of unserviceable materials by transporting and dumping in the near-by low level areas within a lead of 100 metres. All as per instructions of Engineer-in-charge. RCC works including stacking of steel bars.			
2	8	CUM	Dismantling / removing / demolishing as the case may be of the following by manually/mechanical means and carefully stacking the serviceable materials at site of work or conveying and handing over the same at BHEL stores and disposal of unserviceable materials by transporting and dumping in the near-by low level areas within a lead of 100 metres. All as per instructions of Engineer-in-charge. Plain Cement Concrete.			
3	9	CUM	Dismantling / removing / demolishing as the case may be of the following by manually/mechanical means and carefully stacking the serviceable materials at site of work or conveying and handing over the same at BHEL stores and disposal of unserviceable materials by transporting and dumping in the near-by low level areas within a lead of 100 metres. All as per instructions of Engineer-in-charge. Brick work in cement mortar			
4	7	CUM	Dismantling / removing / demolishing as the case may be of the following by manually/mechanical means and carefully stacking the serviceable materials at site of work or conveying and handing over the same at BHEL stores and disposal of unserviceable materials by transporting and dumping in the near-by low level areas within a lead of 100 metres. All as per instructions of Engineer-in-charge. Stone rubble masonry in cement mortar			

Place
DateSignature of the Bidder
(NAME & ADDRESS WITH SEAL)

	BHARAT HEAVY ELECTRICALS LIMITED POWER PLANT PIPING UNIT THIRUMAYAM- 622 507 CONTRACTS DEPARTMENT Phone : 04333279551 E.mail : ilango@bheltry.co.in Website : www.bhel.com
---	---

Tender No:PPPU:WC:14:015

Tender Notice

Dt. 04.10.2014

5	220	CUM	Earthwork excavation (TRENCHES) in soils given below by mechanical means (Hydraulic excavator)/manual means and depositing the excavated earth at suitable places within the initial lead of 50 meter and initial lift of 1.5 meter for foundation in building works, roads, narrow drains, sewers, bridges, pipe lines etc., sectioning the subgrade to proper level and grade, watering and consolidating the subgrade to receive concrete bed, all as per standard specifications and instructions of Engineer-in-charge. Rate also includes bailing or pumping out water during excavation due to subsoil water, rain etc. All kinds of soil except rock			
6	50	CUM	Earthwork excavation (TRENCHES) in soils given below by mechanical means (Hydraulic excavator)/manual means and depositing the excavated earth at suitable places within the initial lead of 50 meter and initial lift of 1.5 meter for foundation in building works, roads, narrow drains, sewers, bridges, pipe lines etc., sectioning the subgrade to proper level and grade, watering and consolidating the subgrade to receive concrete bed, all as per standard specifications and instructions of Engineer-in-charge. Rate also includes bailing or pumping out water during excavation due to subsoil water, rain etc. Ordinary rock			
7	77	CUM	Earthwork excavation (TRENCHES) in soils given below by mechanical means (Hydraulic excavator)/manual means and depositing the excavated earth at suitable places within the initial lead of 50 meter and initial lift of 1.5 meter for foundation in building works, roads, narrow drains, sewers, bridges, pipe lines etc., sectioning the subgrade to proper level and grade, watering and consolidating the subgrade to receive concrete bed, all as per standard specifications and instructions of Engineer-in-charge. Rate also includes bailing or pumping out water during excavation due to subsoil water, rain etc. Hard rock (blasting prohibited)			
8	200	CUM	Earthwork excavation (TRENCHES) in soils given below by mechanical means (Hydraulic excavator)/manual means and depositing the excavated earth at suitable places within the initial lead of 50 meter and initial lift of 1.5 meter for foundation in building works, roads, narrow drains, sewers, bridges, pipe lines etc., sectioning the subgrade to proper level and grade, watering and consolidating the subgrade to receive concrete bed, all as per standard specifications and instructions of Engineer-in-charge. Rate also includes bailing or pumping out water during excavation due to subsoil water, rain etc. Hard rock (requiring blasting)			

Place
DateSignature of the Bidder
(NAME & ADDRESS WITH SEAL)



BHARAT HEAVY ELECTRICALS LIMITED

POWER PLANT PIPING UNIT

THIRUMAYAM- 622 507

CONTRACTS DEPARTMENT

Phone : 04333279551

E.mail : ilango@bheltry.co.in

Website : www.bhel.com

Tender No:PPPU:WC:14:015

Tender Notice

Dt. 04.10.2014

9	135	CUM	Providing and laying in position plain cement concrete of specified grade including consolidation, curing etc. complete, all as per standard specifications. All works up to plinth level. Rate excludes cost of centring and shuttering. 1:4:8 with graded stone aggregate 40 mm nominal size.			
10	220	SQM	Damp proof course with cement mortar 1:3, 12 mm thick mixed with water proofing compound (Accoproof or Impermo or equivalent) at 1 Kg per 50 Kg of cement for water facing surfaces etc. complete., all as per standard specifications.			
11	28	MT	Straightening, cutting, bending, placing in position of MS/CTD bars and binding with MS binding wires of 18/20 gauge etc. for reinforcement of RCC works. Rate includes cover blocks, cost of binding wire, conveyance of MS/ CTD bars from BHEL stores to site of work, labour etc. complete. MS/CTD bars will be supplied by BHEL at Stores at free of cost.			
12	275	SQM	Centring and shuttering including strutting, propping, assembling etc. and removal of form work. Up to a maximum height of 4.50 metre of each floor and also up to floor five level. Foundations, footings, bases of columns, equipment foundations, precast slabs, kerbs etc. for mass concrete.			
13	235	SQM	Centring and shuttering including strutting, propping, assembling etc. and removal of form work. Up to a maximum height of 4.50 metre of each floor and also up to floor five level. Walls (any thickness) including attached pilasters, plinth, stairs, chimney, shafts and string courses etc.			
14	95	SQM	Centring and shuttering including strutting, propping, assembling etc. and removal of form work. Up to a maximum height of 4.50 metre of each floor and also up to floor five level. Pockets or holes in foundations for holding down bolts.			
15	100	KG	Fabrication and fixing in position of M.S inserts out of M.S plates, flats, rounds, angles etc., including necessary lugs made of rounds or flats, sizing and cutting to required lengths, threading, bolting and welding as required and placing the same in position in both plain and reinforced cement concrete members, including adjusting the shuttering if necessary, tying and holding to correct level and line. Rate includes cost of all materials, labour etc., complete but excluding raw steel sections which will be supplied by BHEL at Stores at free of cost.			
16	1300	KG	Conveying all types & sizes of holding down bolts, nuts, washers etc. from BHEL Stores to site of work and fixing in proper level, line, alignment etc., all as per drawings and instructions of Engineer-in-charge. Rate excludes cost of bolts, nuts, washers etc.			

Place
Date

Signature of the Bidder
(NAME & ADDRESS WITH SEAL)

	BHARAT HEAVY ELECTRICALS LIMITED POWER PLANT PIPING UNIT THIRUMAYAM- 622 507 CONTRACTS DEPARTMENT Phone : 04333279551 E.mail : ilango@bheltry.co.in Website : www.bhel.com
---	---

Tender No:PPPU:WC:14:015

Tender Notice

Dt. 04.10.2014

17	280	CUM	Providing and laying in position machine batched, machine mixed and machine vibrated design mix of reinforced cement concrete of specified grade for structural elements using 10 to 20 mm hard broken granite stone jelly, excluding cost of centring, shuttering, finishing and reinforcement but including admixtures in recommended proportions (as per IS:9103) to accelerate, retard setting of concrete, improve workability without impairing strength and durability, all as per directions of Engineer-in-charge. M-20 Grade reinforced cement concrete. All work in foundation, basement and up to Floor V level.			
18	45	SQM	Providing and fixing in position of 12 mm thick bitumen impregnated fibre board conforming to IS:1838 including cost of primer, sealing compound in expansion joints.			
19	150	CUM	Flooring with reinforced cement concrete of mix 1:2:4 using 40 mm and downgraded hard broken granite stone jelly for thickness varying from 100 to 500 mm laid in panels not exceeding 6 x 30 m between expansion joints, including necessary vibration using needle / board / screed vibrators, all as required including necessary shuttering, painting the sides with bitumen, but excluding fabrication charges for reinforcement, all as per standard specifications.			
20	550	SQM	Floor finish with 40 mm thick granolithick flooring over the concrete base while it is wet for proper bonding, the bottom 25 mm thick consisting of one part of cement and one part of 6 mm gauge hard broken granite stone chips (the proportion being by volume) and the top 15 mm finished with hardening compound of proportion one part of hardanite (ironite or equivalent) four parts of cement and eight parts of 6 mm gauge blue granite stone chips (the proportion being by weight) including finishing and painting the sides with bitumen etc., complete, all as per standard specifications.			
21	10	MT	Collection from BHEL stores and transporting the raw structural steel sections to the contractor's site fabrication shop, fabrication of steel work including all materials going into the process of fabrication and forming an integral part of the steel work together with all shop welding including using low hydrogen electrode wherever necessary, all as per drawings and standard specifications. Rate includes delivery of fabricated steel work at erection site ready for erection, including preparation and supply of drawing office despatch list for BHEL's approval, all charges for packing (wherever called for) handling, conveying, stacking and all other incidental charges both for raw materials and fabricated steel works. Rate excludes raw structural steel sections which will be supplied by BHEL at stores at free of cost.			

Place
DateSignature of the Bidder
(NAME & ADDRESS WITH SEAL)

	BHARAT HEAVY ELECTRICALS LIMITED POWER PLANT PIPING UNIT THIRUMAYAM- 622 507 CONTRACTS DEPARTMENT
	Phone : 04333279551 E.mail : ilango@bheltry.co.in Website : www.bhel.com

Tender No:PPPU:WC:14:015

Tender Notice

Dt. 04.10.2014

22	10	MT	Carrying from stacks at erection site to erection positions and erection of fabricated steel work including all handling, conveying, assembling, hoisting, erecting in position and site welding and or bolting, alignment of structures, all as per drawings and standard specifications. Rate includes bolts & nuts, hire for welding tools and plants, labour etc., but excluding cost of fabricated components. If required, power will be given free of cost by BHEL. Weight of fasteners will not be accounted for payment.			
23	150	CUM	Extra for every additional lead of 10 metre or part thereof over the initial lead for all kinds of soil.			
24	280	CUM	Filling available excavated earth (excluding rock) in trenches, plinth, sides of foundation etc. in layers not exceeding 20 cm in depth, consolidating each deposited layer by ramming and watering, lead up to 50 m and lift up to 1.5 m etc. complete.			
25	270	CUM	Conveyance of earth, sand, gravel, rough stone, broken stone, brick bats (debris) etc. by contractor's own lorry including loading, leading, unloading, stacking or spreading, all as per instructions of Engineer-in-charge. Payment for conveyance of earth will be made based on pit measurement and for other items based on stack measurements. Beyond 1 Km but up to 2 Km			
26	45	CUM	Supply and filling with river sand in foundation, plinth, under floor etc. including watering, ramming, consolidating and dressing complete.			
27	4	CUM	Grouting the H.D bolts, underneath the base plates etc., after alignment with non-shrink high strength cementitious grout of such as Tec. Grout 20/40 or Pidigrout 5M/10M or Flogrout 40/60 or Conbextra GP1/GP2 or any other equivalent grout, all as per instructions of Engineer in charge and as per standard specifications. Rate includes cost of non-shrink grout, cleaning the sleeves/pockets, tools, labour etc., complete.			
28	225	CUM	Extra for every additional lift of 1.5 metre or part thereof in : Ordinary or hard rock			
29	200	HOURLY	Hire charges for engaging earth moving machinery (pockline) to attend to channeling works at river bed, pipe line burst works, cleaning the areas including uprooting thorny plants/heavy jungles/trees etc.of all heights and leveling the areas thereafter including all debris etc., all as per instructions of Engineer-in-charge. Rate includes hire, fuel, operation charges, to and fro charges for machinery, all labour and all other incidentals etc., complete.			

Place
DateSignature of the Bidder
(NAME & ADDRESS WITH SEAL)



BHARAT HEAVY ELECTRICALS LIMITED

POWER PLANT PIPING UNIT

THIRUMAYAM- 622 507

CONTRACTS DEPARTMENT

Phone : 04333279551

E.mail : ilango@bheltry.co.in

Website : www.bhel.com

Tender No:PPPU:WC:14:015

Tender Notice

Dt. 04.10.2014

30	60	SQM	Precasting and fixing in position of RCC cable trench cover slabs of following thickness in mix 1:2:4 using graded stone aggregate 12 mm nominal size with top 15 mm thick finished with hardening compound of proportion one part of ironite or equivalent, four parts of cement and eight parts of 6 mm gauge hard granite stone chips (the proportion being by weight) including welding reinforcement rods to the frame work, all as per drawing, specifications and instructions of Engineer-in-charge but excluding cost of M.S frame work which will be paid separately. Reinforcement rods and M.S frames will be supplied by BHEL at stores at free of cost. 69mm thick slab			
31	40	M	Providing and placing in position PVC water stops serrated with central bulb, 225 mm wide & 8-11 mm thick for construction / expansion joints between two RCC members and fixed to the reinforcement with binding wire before pouring concrete etc. complete.			
32	60	CUM	Random rubble masonry in foundation and basement in the mix given below including simultaneous flush pointing, all as per standard specifications. Cement mortar 1:5			
33	85	CUM	Brick work with F.P.S bricks (second class ground moulded chamber bricks) of class designation 50/75 in foundation and plinth in: Cement mortar 1:5			
34	200	SQM	Dismantling / removing / demolishing as the case may be of the following by manually/mechanical means and carefully stacking the serviceable materials at site of work or conveying and handing over the same at BHEL stores and disposal of unserviceable materials by transporting and dumping in the near-by low level areas within a lead of 100 metres. All as per instructions of Engineer-in-charge. G.I / Aluminium sheets from roofs and side cladding including ridges, valleys, gutters etc.			
35	10	MT	Dismantling / removing / demolishing as the case may be of the following by manually/mechanical means and carefully stacking the serviceable materials at site of work or conveying and handing over the same at BHEL stores and disposal of unserviceable materials by transporting and dumping in the near-by low level areas within a lead of 100 metres. All as per instructions of Engineer-in-charge. Steel structures / steel works in built up sections including bolts, nuts, cutting rivets, welding, dismembering, preparation of DODL etc.			

Place
Date

Signature of the Bidder
(NAME & ADDRESS WITH SEAL)



BHARAT HEAVY ELECTRICALS LIMITED

POWER PLANT PIPING UNIT

THIRUMAYAM- 622 507

CONTRACTS DEPARTMENT

Phone : 04333279551

E.mail : ilango@bheltry.co.in

Website : www.bhel.com

Tender No:PPPU:WC:14:015

Tender Notice

Dt. 04.10.2014

36	3	MT	Painting one priming coat with approved primer over structural steel works in roof structures, columns etc., including preparing the surfaces by thoroughly cleaning oil, grease, dirt and other foreign matters and scoured with wire brushes, fine steel wool scrapers and sand paper, all as per standard specifications. Red oxide primer			
37	5	EACH	Providing and fixing in position of brass wheel valve / gate valve of approved brand with C.I wheel etc. complete. (ISI marked) 100 mm nominal bore			
38	4	MT	Fabrication and fixing in position of M.S frames for cable trench cover slabs in required sizes using M.S angles, plates, flats etc., which will be supplied by BHEL at Stores at free of cost, all as per drawings and instructions of Engineer-in-charge. Rate includes conveyance of raw materials from BHEL stores to contractors fabrication shop, fabrication charges including cutting, welding, preparing and supplying DODL's for BHEL's approval, supply of fabricated frames at site of work, fixing in proper position etc., complete.			
39	350	SQM	Plastering with cement mortar as per standard specifications. In Cement mortar 1:5, 15mm thick			
40	100	SQM	White washing on surfaces using Janathacem or equivalent material to give an even shade including cleaning, brushing of walls and preparing surfaces in accordance with standard specifications. Rate includes cost of all materials, labour, curing etc., complete. Three coats			
41	325	SQM	Painting with exterior emulsion paint (ACE or any other equivalent and approved brand) of approved shade on surfaces to give an even shade including preparing the surfaces, removal of dirt, thorough cleaning by watering etc., all as per standard specifications. Rate includes cost of necessary plaster of paris and putty wherever required, labour and all incidentals etc. complete. Two coats			
42	80	CUM	Extra for Brick work in superstructure above plinth up to floor three level in all shapes and sizes.			
43	200	SQM	Applying one coat of cement primer of approved brand and manufacturer on wall surfaces.			

Place
Date

Signature of the Bidder
(NAME & ADDRESS WITH SEAL)

	BHARAT HEAVY ELECTRICALS LIMITED POWER PLANT PIPING UNIT THIRUMAYAM- 622 507 CONTRACTS DEPARTMENT Phone : 04333279551 E.mail : ilango@bheltry.co.in Website : www.bhel.com
---	---

Tender No:PPPU:WC:14:015

Tender Notice

Dt. 04.10.2014

44	50	M	Supply RCC pipes (NP2 Class) of following sizes with collars at site of work, lowering to trench, laying to proper grade and alignment, joining the collars with stiff mixture of cement mortar 1 : 2, testing of joints etc., but excludes cost of cement which will be supplied by BHEL at stores at free of cost. 250 mm dia			
45	50	M	Providing and laying PVC water pipes and specials conforming to ISS in trenches, joining with proper adhesive as suggested by manufacturers etc. complete. (External work) Earth work excavation for trenches and refilling will be paid separately. PVC Pipe 160 mm OD (6 kg/Sq.cm)			
46	50	M	Providing and fixing G.I pipes and specials (B - Class) of approved brand with G.I fittings and clamps on walls & floors, including cutting and making good the walls & floors etc. complete. (Internal work - exposed on walls) 100 mm dia nominal bore.			
47	440	SQM	Conveying from BHEL stores to site of work, sizing as required, hoisting and fixing in proper position of Aluminium-Zinc Alloy coated rib profile sheets with accessories such as ridge pieces, barge boards, curves etc., for roofing, side cladding etc. with necessary self drilling/self tapping screws of size 5.50 x 55 mm with EPDM seal or with polymer coated J or L hooks, bolts & nuts 8 mm dia with bitumen and G.I limpet washers filled with white lead complete up to any pitch in horizontal/vertical or curved surfaces with necessary G.I hook bolts, crank bolts with nuts, G.I and bitumen washers etc., complete, all as per drawings, specifications and instructions of Engineer-in-charge. Rate excludes cost of Aluminium-Zinc Alloy sheets and its accessories such as ridge pieces, barge boards, curves etc. which will be supplied by BHEL at Stores at free of cost.			
48	40	M	Providing and fixing G.I pipes and specials (B - Class) of approved brand with G.I fittings and clamps on walls & floors, including cutting and making good the walls & floors etc. complete. (Internal work - exposed on walls) 150 mm dia nominal bore.			
49	50	M	Providing and fixing G.I pipes and specials (B - Class) of approved brand with G.I fittings and clamps on walls & floors, including cutting and making good the walls & floors etc. complete. (Internal work - exposed on walls) 25 mm dia nominal bore.			

Place
DateSignature of the Bidder
(NAME & ADDRESS WITH SEAL)

**BHARAT HEAVY ELECTRICALS LIMITED**

POWER PLANT PIPING UNIT

THIRUMAYAM- 622 507

CONTRACTS DEPARTMENT

Phone : 04333279551

E.mail : ilango@bheltry.co.inWebsite : www.bhel.com

Tender No:PPPU:WC:14:015

Tender Notice

Dt. 04.10.2014

50	50	M	Providing and fixing G.I pipes and specials (B - Class) of approved brand with G.I fittings and clamps on walls & floors, including cutting and making good the walls & floors etc. complete. (Internal work - exposed on walls) 32 mm dia nominal bore.			
51	50	M	Providing and fixing G.I pipes and specials (B - Class) of approved brand with G.I fittings and clamps on walls & floors, including cutting and making good the walls & floors etc. complete. (Internal work - exposed on walls) 50 mm dia nominal bore.			
52	5	EACH	Providing and fixing in position of brass wheel valve / gate valve of approved brand with C.I wheel etc. complete. (ISI marked) 15 to 25 mm nominal bore			
53	5	EACH	Providing and fixing in position of brass wheel valve / gate valve of approved brand with C.I wheel etc. complete. (ISI marked) 50 mm nominal bore			
54	1000	KG	Extra for providing and mixing water proofing material 'Impermo' or equivalent in cement concrete work at 1 Kg per 50 Kg of cement.			
55	700	KG	Providing holding down bolts of required sizes with nuts, washers etc. and fixing in proper level, line, alignment etc., all as per drawings and instructions of Engineer-in-charge. Rate includes cost of steel materials, bolts, nuts, washers, fabrication and machining charges, fixing, all labour etc. complete. Bolts including nuts & washers etc. complete in all sizes & lengths.			
56	90	SQM	Finishing the top of all floors with 25 mm thick cement concrete (without using sand) in the proportion of one part of cement and three parts of 3 to 10 mm gauge hard broken granite stone chips, finishing the surfaces smooth, rounding of corners, curing, providing borders etc., complete, all as per standard specifications. (Ellis pattern flooring)			
57	10	MT	Painting (excluding priming coat) on structural steel works in roof structures, columns etc. with synthetic enamel paint of approved brand and shade, brushing to give an even shade including cleaning the surfaces of all dirt, dust and other foreign matters, scaffolding charges etc. complete. All as per standard specifications. Two coats			

Place
DateSignature of the Bidder
(NAME & ADDRESS WITH SEAL)



BHARAT HEAVY ELECTRICALS LIMITED

POWER PLANT PIPING UNIT

THIRUMAYAM- 622 507

CONTRACTS DEPARTMENT

Phone : 04333279551

E.mail : ilango@bheltry.co.in

Website : www.bhel.com

Tender No:PPPU:WC:14:015

Tender Notice

Dt. 04.10.2014

58	1	MT	Conveying from BHEL stores to site of work cutting to size and fixing in position of 75 x 75 x 6 mm or other size M.S angles in required lengths for forming the rebates in cable trench (for fixing the cable trench cover slabs) including welding in position of dowel bars to the angles and embedding the angle iron frame in the flooring concrete in proper line and level, all as per drawings and instructions of Engineer-in-charge. Rate includes loading, unloading, handling, welding and other incidental charges, preparing and supplying of DODL's for approval etc. complete, but excluding cost of M.S angles and dowel bars which will be supplied by BHEL at Stores at free of cost.			
59	25	SQM	Providing polyester sun control film of approved brand (GARWARE or equivalent) and shade to glazed panels in doors / windows / ventilators / partitions etc. with proper adhesive, all after removing the existing damaged film if available etc. complete. All as per instructions of Engineer in charge. Rate includes cost of all materials, scaffolding charges, labour, all other incidentals etc., complete. Non reflective Type - Premium Grade with Scratch Resisting Coating			
60	40	SQM	Centring and shuttering including strutting, propping, assembling etc. and removal of form work. Up to a maximum height of 4.50 metre of each floor and also up to floor five level. Suspended floors, roofs, landings, balconies, access platform and sunshades.			
61	10	SQM	Centring and shuttering including strutting, propping, assembling etc. and removal of form work. Up to a maximum height of 4.50 metre of each floor and also up to floor five level. Lintels, beams, plinth beams, girders, bressumers and cantilevers			
62	30	SQM	Ceiling plastering with cement mortar 1:3, 6mm thick as per standard specifications.			
63	60	SQM	Distempering using oil bound washable distemper of approved brand and shade on surfaces including cleaning, brushing, preparing the surfaces even and sand papered smooth in accordance with standard specifications. Three coats (A priming coat with approved primer and two coats of distempering).			
64	5	CUM	Providing weathering course on top of roof slab with 20 mm size brick jelly and pure lime (no sand) in the proportion of 32 : 12.5 to the required thickness, well beaten with wooden battens, so as to secure adequate slope, all as per standard specifications and instructions of Engineer-in-charge.			
65	30	SQM	Providing weathering course on top of roof slab with one course of split tiles or pressed flat tiles of 17 to 20 mm thick and of approved brand & size, set in cement mortar 1:3 with an admixture of crude oil at 10% by weight of cement, 12 mm thick bedding layer including pointing the tiles with the same oiled mortar etc., complete, all as per standard specifications.			

Place
Date

Signature of the Bidder
(NAME & ADDRESS WITH SEAL)



BHARAT HEAVY ELECTRICALS LIMITED

POWER PLANT PIPING UNIT

THIRUMAYAM- 622 507

CONTRACTS DEPARTMENT

Phone : 04333279551

E.mail : ilango@bheltry.co.in

Website : www.bhel.com

Tender No:PPPU:WC:14:015

Tender Notice

Dt. 04.10.2014

66	30	KG	<p>Providing and fixing anodised aluminium work for doors, windows, ventilators and partitions with extruded built up standard tubular sections / appropriate Z sections of approved make conforming to IS:733 & 1285, fixed with rawl plugs & screws or with fixing clips, or with expansion hold fasteners including necessary filling up of gaps at junctions, at top, bottom and sides with required PVC / neoprene felt etc. Aluminium sections shall be smooth, rust free, straight, mitred and joined mechanically wherever required including cleat angle, aluminium snap beading for glazing / panelling, C.P brass / stainless steel screws, all complete as per architectural drawings and instructions of Engineer-in-charge. (Glazing and panelling to be paid for separately)</p> <p>For shutters of doors, windows and ventilators including providing and fixing hinges / pivots and making provision for fixing of fittings wherever required including cost of PVC/ neoprene gasket required. (Fittings shall be paid for separately) Anodised aluminium (anodised transparent or dyed to required shade according to IS 1868, minimum anodic coating of grade AC 15)</p>			
67	10	KG	<p>Providing and fixing anodised aluminium work for doors, windows, ventilators and partitions with extruded built up standard tubular sections / appropriate Z sections of approved make conforming to IS:733 & 1285, fixed with rawl plugs & screws or with fixing clips, or with expansion hold fasteners including necessary filling up of gaps at junctions, at top, bottom and sides with required PVC / neoprene felt etc. Aluminium sections shall be smooth, rust free, straight, mitred and joined mechanically wherever required including cleat angle, aluminium snap beading for glazing / panelling, C.P brass / stainless steel screws, all complete as per architectural drawings and instructions of Engineer-in-charge. (Glazing and panelling to be paid for separately)</p> <p>For fixed portion - Anodised aluminium (anodised transparent or dyed to required shade according to IS 1868, minimum anodic coating of grade AC 15)</p>			
68	15	SQM	<p>Providing and fixing glazing in aluminium door, window, ventilator shutters and partitions etc. with PVC/ neoprene gasket etc. complete as per drawing and instructions of Engineer-in- charge. (Cost of aluminium snap beading shall be paid in basic item.)</p> <p>With float glass panes of 4 mm thick</p>			

Place
Date

Signature of the Bidder
(NAME & ADDRESS WITH SEAL)



BHARAT HEAVY ELECTRICALS LIMITED

POWER PLANT PIPING UNIT

THIRUMAYAM- 622 507

CONTRACTS DEPARTMENT

Phone : 04333279551

E.mail : ilango@bheltry.co.in

Website : www.bhel.com

Tender No:PPPU:WC:14:015

Tender Notice

Dt. 04.10.2014

69	5	EACH	Supply & fixing the following furniture fittings of approved brand & quality (ISI marked) in the appropriate position of doors, windows, ventilators, cupboards etc. with appropriate screws, nails etc., all as per standard specifications & instructions of Engineer in charge. D type Anodised Aluminium handle - 125 mm			
70	10	EACH	Supply & fixing the following furniture fittings of approved brand & quality (ISI marked) in the appropriate position of doors, windows, ventilators, cupboards etc. with appropriate screws, nails etc., all as per standard specifications & instructions of Engineer in charge. 250 x 11/12 mm Anodized Aluminium tower bolt			
71	5	EACH	Providing and fixing 100 mm brass lock (mortise latch & lock with six levers) for aluminium doors including necessary cutting and making good etc. complete.			
72	10	SQM	Supply and fixing the following boards/sheets of approved brand & quality in panelling fixed in aluminium doors/window shutters/partition frames etc. with C.P brass/stainless steel screws etc. complete, all as per drawings, specifications and instructions of Engineer in charge. Rate includes cutting to required sizes, wastages etc. complete. Rate excludes cost of respective frame works. Pre laminated (both sides) particle boards - 12 mm thick - (Novapan-Standard or equivalent)			
73	10	SQM	Providing and fixing factory made ISI marked steel glazed doors, windows and ventilators side/top/centre hung with beading etc. complete of standard rolled steel sections, joints mitred and flash butt and sash bars tenoned and riveted with 15 x 3 mm lugs, 10 cm long, embedded in cement concrete blocks 15 x10 x 10 cm of 1:3:6 or with wooden plugs and screws or rawl plugs and screws or with fixing clips or with bolts and nuts as required, including providing and fixing of hinges, pivots, 4 mm plain glass panes with glazing clips and special metal-sash putty of approved make, handles, pegstays etc. complete including a priming coat of approved steel primer excluding the cost of metal beading and other fittings. Rate includes dismantling the masonry and making good all damages etc. complete.			
74	12	SQM	Providing silver anodized aluminium alloy grills (DECOGRILLE) of following design and fixing in proper position in windows/ventilators/balconies/partitions/ fences/racks etc. with necessary appropriate type, material, brand & quality screws as per manufacturers recommendation etc. complete, all as per the instructions of Engineer-in-charge. DECOGRILLE Design No. DG 202 with 7.50 mm plates			

Place
Date

Signature of the Bidder
(NAME & ADDRESS WITH SEAL)