



Bharat Heavy Electricals Limited

(A Govt. of India undertaking)

Boiler Auxiliaries Plant, Ranipet – 632406, Tamilnadu.

INFORMATICS CENTRE

BAP:IC:3205A:DATED 20/03/2015 :: Email and Proxy solutions support and maintenance

TENDER SPECIFICATION FOR EMAIL AND PROXY SOLUTIONS SUPPORT AND MAINTENANCE AT BHEL RANIPET

Index

1	Introduction	
2	Eligibility Criteria	
3	Current mail and proxy solution implemented in BHEL, Ranipet	
4	Scope of Work	
5	Un – Priced Bid Format	Annexure I
6	General Conditions	
7	Third Party Non-Disclosure Agreement	Annexure II
8	Contract Agreement	Annexure III
9	EFT	
10	Price Bid Format	Annexure IV
11	Confirmation of not blacklisted	Annexure V
12	Confirmation of not bankrupted	Annexure VI

Prepared By	Reviewed By	Approved By
S.Gayathri, Engineer/IC	M P Sivasubramani ,SM/IC	B. Venkateshwar , AGM/IC

1.0 Introduction

BHEL is the largest engineering and manufacturing enterprise in India in the energy related/infrastructure sector. BHEL was established more than 50 years ago, ushering in the indigenous Heavy Electrical Equipment industry in India - a dream that has been more than realized with a well-recognized track record of performance.

BHEL's Ranipet Complex is one of the leading boiler auxiliaries manufacturers in the world and India's largest engineering and manufacturing enterprises providing total boiler solutions for utility, industrial, captive power and heat recovery applications.

The existing mail and proxy setup in BHEL, Ranipet was installed in 2009 and was maintained and supported by the original vendor who installed the system for the past 5 years. In order to maintain the current setup and to support in case of any issues such that mail and proxy solutions are available without any interruption, it is required to go for maintenance and support of the same for one year.

2.0 Eligibility Criteria

Eligibility criteria for Bidders

- a. The bidder should be a company/firm that is registered/incorporated in India.
- b. The bidder should not be involved in any bankruptcy Issues. The bidder should give a declaration to this effect in the format given in Annexure VI.
- c. The Average annual financial turnover of the bidder during the last 3 years ending 31st March of the previous year should be at least 1.01 lakhs. Supporting documents in form of Copy of Balance sheet, Profit & Loss Account duly certified & audited by Chartered Accountant has to be submitted by the bidder.
- d. The bidder having successfully completed similar works during the last 7 years ending 28th February, 2015 should be either of the following:
 - i) Three similar completed works costing not less than amount equal to 1.34 lakhs
 - OR
 - ii) Two similar completed works costing not less than amount equal to 1.69 lakhs
 - OR
 - iii) One similar completed work costing not less than amount equal to 2.69 lakhs

Here similar works means

- a) Installation/Support/Maintenance of Email and Proxy solutions

Note:-Bidder has to submit the PO copies or completion certificates justifying the above mentioned conditions.

- e. The bidder should not be under Hold or Blacklist by any of BHEL units as on bid opening date, for any of product or service related to Mail and Proxy. The bidder should give a declaration on this in the format given in Annexure V.
- f. The bidder can also be an MSME vendor registered as per MSME act. The guidelines issued by government from time to time for engaging MSME vendor, will be applicable. However, there can be no relaxation in the eligibility criteria mentioned above.

3.0 Current mail and proxy solution implemented in BHEL, Ranipet:

3.1 Schematic diagram of Current mail and proxy solution

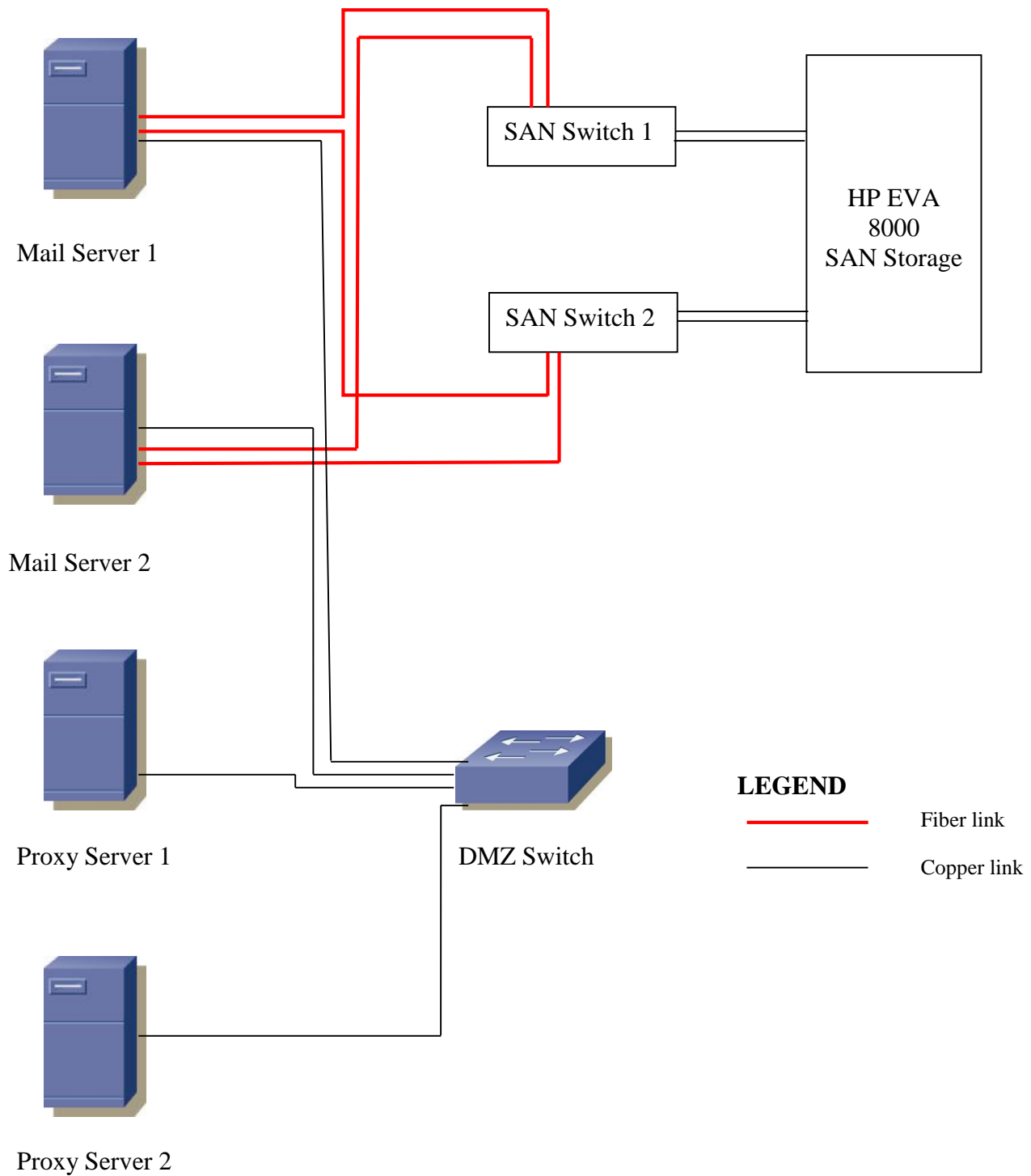

3.2 Technical Specifications of Existing Setup at BHEL, Ranipet:

- The existing email solution includes Internet Mail as well as the storage connected to these servers
 - Mail includes sending and receiving mails to other domains through Internet and to local domain through LAN. (MTA: qmail – 1.03)
 - Existing SAN storage with 1.6 TB
- Connectivity of mail server to the two ISP (BSNL 16Mbps and Railtel 6Mbps leased line) available with BHEL.
- The solution is interfaced with the existing Firewall available at Primary Site.
- Support for 1500 email users at present and it may go up to 2000 in the next 5 years.
- Backup and restoration process for data.
- Backup strategy for email service. (Take backup from HP Data Protector for Email mailbox, MySQL Backup of Horde, LDAP backup)
- Anti-spam solution (Mail-SpamAssassin-3.3.1)
- Efficient Virus protection for email (incoming and outgoing) and Internet traffic. (clamav-0.96)
- Mail Archival solution. (mailarchiva_server_opensource_linux_v1_9_13)
- Administrator can set quota limit for individual users' mailboxes
- SSL support with SSL certificate.
- A web interface is provided to access the email system:
 - The Mail User Agent used is WEBMAIL and the application used for implementing the webmail solution is HORDE. (MUA: Horde Groupware Webmail Edition Revision: 1.2)
 - The web interface works with all versions of Internet Explorer 6, 7, 8, Firefox 2 & 3, and recent releases of Opera and provides versions using Javascript and versions not using Javascript.
 - Heartbeat cluster exists between two webmail servers (heartbeat-2.1.4-11.el5)
- BHEL ISMS requirements for email is met.
- Support for various email client softwares such as Microsoft Outlook , Thunderbird etc.
- Personal and enterprise wide distribution lists

- Personal and enterprise wide address books
- Mail auto respond, auto forward and other rules
- Log reports and statistics provided
- Data backup solution provided
- Disaster recovery for primary mail server failure provided as part of ISMS BCP Procedure.
- Long term Mail storage on SAN
- Common mailboxes for requested users on proper approval.
- User should authenticate to use email service through LDAP (openldap-2.3.43-3.el5)
- Single copy of message stored for multiple recipients
- Attachments for all users sent as links hosted in the Intranet.
- Spam mail delivered to separate mailbox/folder

Internet Proxy

- The Internet gateway allows access control based on
 - Client hostname or IP address
 - Username
 - MAC address
 - Server URL
 - Server name or IP
- Users authenticate to the gateway to access Internet.
- Cluster configuration implemented between two proxy servers.
- Authentication is done through a separate ldap installed in the proxy server.
- Connection established between proxy server to the two ISP (BSNL 16Mbps and Railtel 6Mbps leased line) available with BHEL.
- Proxy server LDAP Backup
- Access based on Black Lists (BLs)
- Virus/Spyware/Malware scanning for HTTP traffic

4 Scope of Work

4.1 Technical Support and Maintenance

Technical support and maintenance must be provided for a minimum period of **one year** for the solutions provided.

Support to be provided **on-site with one man power** as Resident Engineer.

The vendor has to maintain necessary Log Book for the work carried out for the entire period. The log book should contain date wise activities done by the Engineer such as monitoring logs in the server, taking backup on a daily basis, user complaints attended and completed, any changes done in the server such as software upgradation and any patches applied, monitoring server CPU and memory utilization, monitoring disk usage space and disk free space and creation, deletion, modification of user accounts etc.

In case of planned absence of any person, suitable replacement shall be made available by the contractor.

When ever the engineer receives any user complaint, the same shall be sorted out within 1 hour . In case of major problems which cannot be sorted out by the resident engineer, he shall escalate the same to his higher authorities and the same shall be sorted out within 6 hours.

Qualified Resident engineer will be posted at BHEL Ranipet. The CV of the Resident Engineer shall be got vetted from BHEL Ranipet.

The Resident Engineer posted :

- Shall be atleast a 4 year BE/BTech degree holder in Electronics/Computers.
- Shall have knowledge in Linux (RHEL), mail and proxy solutions.
- Shall have maintained an **in-house on premise email and proxy solutions.**
- Shall have experience in Linux, Open source mailing and proxy solutions (preferably qmail and squid). Supporting documents for the same is to be submitted at the time of appointment of the Resident Engineer to BHEL,Ranipet.
- Shall observe BHEL working hours and BHEL holidays. BHEL working hours are 8AM to 4:30PM, 6 days a week
- Shall have their own vehicles for movements and shall have mobile phones accessible from BHEL landline/mobile phones.

- The rate quoted shall include **PF & ESI** remittance of the Engineer employed in this work. Therefore the tenderer shall quote inclusive of **PF & ESI** contribution to their Engineer.
- All expenses towards logistics and incidentals, including lodging, boarding, travel, etc., incurred in connection with the execution of this contract shall be borne by the vendor and shall not be reimbursed by BHEL.
- Vendor shall adhere to security procedures of BHEL for material, data, and personnel movement.
- Safety precautions should be taken while doing the work.

4.2 Maintenance Activities for email and proxy servers:

- System monitoring for mail, proxy, webmail and mail archiva server.
- High availability mail and proxy solution with active/active.
- Maintenance of Email and proxy solutions including reports.
- Monitoring of mails, mail traffic, queue clearance, spam and virus traffic, storage, disk space etc...
- Monitoring of Internet browsing.
- Handle user complaints related to mail, proxy, spam and other email and internet issues.
- Provide solutions for changes to be made in the mail or proxy servers on need basis if and only if it is possible without making major changes to the current setup.
- User management of spam mails – tag messages as spam or not-spam
- Check for status of storage volumes connected to mail server and mail archiva server
- Blocking access to sites based on keywords in proxy
- Internet access report by user, IP address, site etc
- All reports may be provided on daily, weekly or monthly basis

4.3 Available Resources

BHEL Ranipet has the following hardware for the current setup.

- 2 Nos. of HP Proliant BL 460c Blade Servers with 3.0GHz Dual Core, Intel Xeon Dual CPU with 32GB Of RAM having 2Nos. of 72.8GB SAS Hard disks.
- 2 Nos of HP Proliant DL580 G4 Server with 4 Nos. of 3.0GHz Intel Xeon processors with 8 GB of RAM having 4 Nos. of 146.4 GB SAS hard disks.
- HP EVA 8000 SAN Storage having 1TB of storage space.
- One 24 port 10/100/1000 Layer 2 switch for connecting Email and Proxy Servers to the network.
- 2 Nos of HP BLc Emulex LPe1105 FC HBA Opt Kit.
- 4 Nos of 15 meters fiber LC-LC patch cords with male connectors on both sides.
- RHEL 5 Advanced Platform.

Annexure I

UNPRICED BID

Sl No	Description	Basic Price in Rs.	Applicable Tax (in %)	Tax Amount in Rs.	Total Amount in Rs.
1	Mailing & Proxy Solution Support for 1 Year: Resident Engineer at BHEL for L1-L2 Issues and Professional Support (L3 & Above Issues)				
GRAND TOTAL					

Note: Bidder has to clearly specify the Tax in % in the format given and fill the remaining blanks in all the columns as 'Quoted' and submit this filled page also while submitting for the Price Bid. In Un-Priced Bid, Please do not fill any prices. Only TAX in % needs to be filled.

5.0 General Conditions

1. EMD

An amount of Rs. 10,000.00(Rupees Twenty Thousand Only) will have to be paid as EMD(Earnest Money Deposit) either cash at our cash office or as DD to be drawn in favor of BHEL, Ranipet Payable at State Bank of India, Mukundarayapuram, (MRPURAM PROJECT Code Number : 07013) Ranipet. In case DD is obtained from other Banks, the same to be "Payable at Ranipet".

Vendors registered with NSIC will be exempted from depositing EMD amount on submission of proper documents as per clause 15.

1.1 EMD by the Tenderer will be forfeited if:

- a. After opening the tender, the bidder revokes the tender within the validity period or increases his earlier quoted rates.
- b. The successful bidder does not commence the work as per the terms of Contract.

1.2 EMD shall be refunded to unsuccessful bidders, **normally within fifteen days of acceptance** of award of work by the successful bidder.

1.3 EMD of successful bidder will be converted to Security Deposit. If Security Deposit is not applicable or provided in other form/mode, EMD will be refunded after commencement of work.

1.4 EMD shall not carry any interest.

2. TERMINATION

- a. BHEL reserves the right to cancel the order for non-performance and non-Compliance of the Scope of the Tender without any monetary or legal obligations
- b. The Contract may be short closed after six months with one month notice period ,if required by BHEL

3. SERVICE TAX

- a. The Bidder shall not include Service Tax in their quoted rates; but the bidder has to separately indicate the Service Tax rate, amount and workings thereof in the Price bid schedule included in the bid documents.
- b. If service tax amount is not indicated separately in the price bid schedule included in the Bid documents, it will be presumed that the quoted rate is inclusive of applicable service tax and bids will be evaluated accordingly.
- c. Bidders have to quote the applicable Service Tax payable in the Price bid format included in the Bid document which shall be considered for evaluation. The same shall be considered for reimbursement against valid documentary evidence.
- d. The documentary evidence should comprise the following documents:
 - Copy of service tax Registration certificate.
 - Copies of challans for deposit of service tax.
 - A certificate from the vendor that the tax collected from BHEL has been remitted to tax authorities and the certificate should be signed by the authorised official of the contractor mentioning name and designation.

4. SECURITY DEPOSIT

- a) Security Deposit shall be collected from the successful tenderer. The rate of Security Deposit will be as below for the business value as mentioned:

Upto Rs.10 Lakhs	: 10%
Above Rs.10 lakhs up to Rs.50 Lakhs	: 1 Lakh + 7.5% of the amount Exceeding Rs.10 Lakhs
Above Rs.50 Lakhs	: Rs.4 Lakhs + 5% of the amount Exceeding Rs.50 Lakhs

The Security Deposit shall be remitted before start of the Work.

- b) Security Deposit may be furnished in any one of the following forms:
- i) Cash (as permissible under the Income Tax Act)
 - ii) Pay Order, Demand Draft in favour of BHEL.
 - iii) Local cheques of Scheduled Banks, subject to realization.
 - iv) Securities available from Post Offices such as National Savings Certificates, Kisan Vikas Patras etc., (Certificates should be held in the name of Contractor furnishing the security and duly pledged in favour of BHEL and discharged on the back).
 - v) Bank Guarantee from Scheduled Banks / Public Financial Institutions as defined in the Companies Act. The Bank Guarantee format should have the approval of BHEL.
 - vi) Fixed Deposit Receipts issued by Scheduled Banks / Public Financial Institutions as defined in the Companies Act. The FDR should be in the name of the Contractor, A/C BHEL, duly discharged on the back.
 - vii) Security Deposit shall also be recovered at the rate of 10% from the running Bills. However, in such cases at least 50% of the Security Deposit should be remitted before the start of the work and the balance 50% may be recovered from the running bills.
 - viii) EMD of the successful tenderer shall be converted and adjusted against the Security Deposit.
 - ix) The security deposit shall not carry any interest.

Note:

Acceptance of Security Deposit against Sl. No. (iv) and (vi) above will be subject to Hypothecation or endorsement on the documents in favor BHEL. However, BHEL will not be liable or responsible in any manner for the collection of interest or renewal of the documents or in any other matter connected therewith. The Earnest Money paid at the time of tender will be adjusted as part of the Security Deposit and the balance amount will be recovered by deduction from the running bills of the contractor at the rates mentioned above.

Security Deposit shall not be refunded except in accordance with the terms of Security Bond or Agreement. No interest shall be allowed on Security Deposits. BHEL shall not be responsible for

any loss of securities, due to liquidation for any other reasons, what-so-ever or any depreciation in the value of the securities while in their charge or for any loss of interest there on.

All compensation or other sums of money payable by the Contractor to BHEL under the terms of this contract or under any other contract with BHEL may be deducted from the Security Deposit or realized by the sale of the securities or from the interest arising therefrom or from any sums which may be due or may become due to the contractor by BHEL and in the event of this Security Deposit being deducted by reason of such deductions or sale, as aforesaid, the Contractor shall within 7 days thereafter, make good in cash or in securities endorsed as aforesaid, any sum by which the Security Deposit has been reduced.

5. Payment Terms :

The payment will be made quarterly in arrears and after receipt of invoice and duly certified by Informatics Centre, BHEL. The rates quoted should include all taxes, levies, duties, cess etc., and no extra payment will be made other than the quoted value.

6. No interest shall be payable by BHEL on EMD/SD if applicable or any money due to the contractor by BHEL.

7. Non-Disclosure Agreement :

The successful bidder should execute a Non-Disclosure Agreement as given in the format in Annexure – II

8. PROCEDURE FOR SUBMISSION OF BIDS

- a. Earnest Money Deposit (EMD): EMD of Rs 10,000/- shall be submitted with the offer, in the form of Demand Draft from any nationalized bank / scheduled bank, drawn in favor of M/s Bharat Heavy Electricals Limited, Ranipet, Payable at Ranipet. EMD is exempted for bidders having valid registration with NSIC (National Small Industries Corporation Ltd).
- b. The bidder shall sign all the pages of the Tender document and all the supporting documents. Signing of the document means that the bidder has fully understood the Tender and complies with all the requirements.
- c. The Price Bid shall be submitted on or before 14:00 Hrs of the due date indicated in the tender notice.
- d. Offer shall be made in a separate envelope, as specified below.

Price Bid

This part shall consist of the following documents in a Single envelope:

- i. Demand Draft for Rs 10,000/ towards EMD (Earnest Money Deposit).
- ii. All pages of the tender document should be signed.
- iii. Un-priced Price Bid format duly signed with the tax break up details
- iv. Copy of Service Tax registration Certificate, TIN No. and PAN No.
- v. Price Bid as per the format given. The prices shall be quoted in Indian Rupees only.
- vi. The offer shall not contain any counter Conditions / Terms by the bidder.

9. MARKING ON THE ENVELOPE

The offer shall be enclosed in a single envelope with bidder's distinctive SEAL and super-scribed with the details given below:

1. "PRICE BID"
2. Tender Reference and Description of the Tender
3. Due Date for Opening of the Tender

The Envelope of Price Bid shall be enclosed in another envelope and submitted with markings specified below:

1. Tender Notice / Tender Reference and Description of the Tender
2. Due Date for Opening of the Tender
3. Bidder's Address and SEAL

Note: Un-sealed envelopes and envelopes not super-scribed as above are liable to be rejected.

10. BID SUBMISSION

Bids shall be sent to the following address:

M.P. Sivasubramani,
Senior Manager, Informatics
Center,
Engineering Building,
BHEL, RANIPET,
TAMILNADU – 632406.

Bids can also be submitted in person in Informatics center on or before the tender due date.

Late / delayed Bids will be rejected.

11. BID OPENING

- a. Price bid shall be opened on the due date and time as specified in the Tender Notification, in the presence of bidders who may like to attend.
- b. Not more than two representatives will be permitted to be present for the tender opening. Representative participating in Tender Opening must bring company's authorization letter in original.
- c. Unsolicited bids shall not be entertained at any stage of the tendering process.
- d. No Literature / Data Sheets other than what is relevant for the offer shall be enclosed. All such enclosures shall be considered as unread and also will not be considered as part of the quotation.
- e. BHEL reserves the right to carry out negotiations with bidder on the tender offer / price.

12. PRICE AND VALIDITY

- a. Price shall be firm throughout the tenure of the contract. Variation of what so ever nature is to Vendor's account. Applicable Taxes shall be quoted separately in unambiguous terms. Invoices for claiming the contract price shall be as per the

prevalent law. BHEL may avail CENVAT/service tax credit and vendors invoice to support the same.

- b. Price should be valid for a period of ninety days from the date of opening of the tender.
- c. Bidder should give the price bid in the format as per **Annexure – IV**.

13. Discrepancy in “words “ & “ Figures “

a) If, in the price structure quoted for the required goods/services/works, there is discrepancy between the unit price and the total price (which is obtained by multiplying the unit price by the quantity), the unit price shall prevail and the total price corrected accordingly, unless in the opinion of the purchaser there is an obvious misplacement of the decimal point in the unit price, in which case the total price as quoted shall govern and the unit price corrected accordingly.

b) If there is an error in a total corresponding to the addition or subtraction of subtotals, the subtotals shall prevail and the total shall be corrected; and

c) If there is a discrepancy between words and figures, the amount in words shall prevail, unless the amount expressed in words is related to an arithmetic error, in which case the amount in figures shall prevail subject of (a) and (b) above.

d) If there is such discrepancy in an offer, the same shall be conveyed to the bidder with target date up to which the bidder has to send his acceptance on the above lines and if the bidder does not agree to the decision of the purchaser, the bid is liable to be ignored.

14. BHEL shall have the right to recover any money due from the contractor from any money due to the contractor under this contract or any other contract or from the security deposit.

15. MSME

MSE suppliers can avail the intended benefits only if they submit along with the offer, attested copies of either EM II certificate having deemed validity (five years from the date of issue of acknowledgement in EM-II) or valid NSIC certificate or EM-II certificate along with attested copy of a CA certificate (as below) where deemed validity of EM II certificate of five years has expired) applicable for the relevant financial year (latest audited). Date to be reckoned for determining the deemed validity will be the last date of bid opening (Part 1 in case of two part bid). Non submission of such documents will lead to consideration of their bid at par with other bidders. No benefit shall be applicable for this enquiry if any deficiency in the above required documents are not submitted before price bid opening. If the tender is to be submitted through e-procurement portal, then the above required documents are to be uploaded on the portal. Documents should be notarized or attested by a Gazetted officer.

All MSE suppliers shall continue to be in PMD with MSE status based on the EM II certificate or valid NSIC certificate.

Any new supplier will be eligible for registration with BHEL as MSE supplier provided at least any one of the following documents are submitted along with application for registration.

- a) Valid NSIC certificate or
- b) Entrepreneurs Memorandum part II(EM II) certificate (valid based on deemed validity of 5 years) or
- c) EM II certificate alongwith attested copy of CA certificate(as per prescribed format as below applicable for the relevant financial year(latest audited) , where the deemed validity of EM II is over.

However credentials of all MSE suppliers will be verified before considering the intended benefits for MSE suppliers as per clause9ii) at the time of tender evaluation.

Certificate by Chartered Accountant on Letter head

This is to certify that M/s.....,
(hereinafter referred to as 'Company') having its registered office at.....
..... is registered under MSMED Act 2006,(Entrepreneur memorandum
No(Part-II)..... dtd:.....
Category:.....(Micro/Small).(Copy enclosed)

Further verified from the Books of Accounts that the investment of the company as per the latest audited financial year as per MSMED Act 2006 is as follows:

1. For Manufacturing Enterprises: Investment in plant and machinery(i.e. original cost excluding land and building and the items specified by the Ministry of Small Scale Industries vide its notification No.S.O.1722(E) dated October 5, 2006:
Rs..... Lacs
2. For Service Enterprises: Investment in equipment(original cost excluding land and building and furniture, fittings and other items not directly related to the service rendered or as may be notified under the MSMED Act, 2006.
Rs..... Lacs

(Strike off whichever is not applicable)

The above investment of Rs.....Lacs is within permissible limit of Rs.....
Lacs for.....Micro/Small(Strike off which is not applicable)Category under
MSMED Act 2006.

Or

The company has been graduated from its original category(Micro/Small)(Strike off which is not applicable) and the date of graduation of such enterprise from its original category is(dd/mm/yyyy) which is within the period of 3 years from the date of graduation of such enterprise from its original category as notified vide S.O.No.3322(E) dated 01-11-2013 published in the gazette notification dated 04-11-2013 by Ministry of MSME.

Date:

(Signature)
Name-

Membership number

Seal of Chartered Accountant

Signature of the Tenderer with seal
(Authorized Signatory)

16. DEDUCTION FOR DOWNTIME

- Vendor shall be responsible for maintaining the mail and proxy solution at the uptime of 99% per calendar month. If any down time due to ISP, power, network outage, hardware etc will not be consider for this calculation.
- Scheduled downtime mutually agreed, to be excluded from calculation of uptime.
- Downtime due to force majeure (1) will be excluded from calculation of uptime.
- Any downtime, other than mentioned in item as above will be excluded for calculation of uptime, if mutually agreed in writing by the bidder and BHEL.
- Availability shall be calculated as follows.

Note: ⁽¹⁾Force Majeure:

Neither party shall be held responsible for non-fulfilment of their respective obligation under this agreement due to the exigency of one or more of the force majeure events such as but not limited to acts of God, War, flood, earthquakes, strikes(s) lockout(s) , epidemics, riots, civil commotion etc. provided on occurrence and cessation of such events, the party affected by these shall give a notice in writing to the other party within 15 days of such occurrence and cessation. If the force majeure conditions continue beyond THREE months, the parties shall then mutually decide about the future course of action.

AVAILABILITY (IN %) = [1- (TOTAL OUTAGE HOURS IN MONTH / TOTAL NO OF HOURS IN MONTH)] X 100%

Bidder should give uptime guarantee of 99% on MONTHLY BASIS. In case uptime falls below the guaranteed level, BHEL / BAP will impose a penalty. Levy of penalties is without prejudice to other rights and remedies available under this agreement. Levy of penalty will be calculated as under:

Uptime (%) Per Month	Penalty in % of monthly value
>= 99	0
>= 98 and < 99	5
>= 97 and <98	10
>= 96 and < 97	15
>= 95 and < 96	20
< 95%	25

17. Tender Opening Date and Time :

Last date for submission of Tender: 13/04/2015 14:00 Hrs and to be submitted at Informatics Centre, BHEL, Ranipet.

Opening of Tender: 13/04/2015 14:30 Hrs at Informatics Centre.

18. Service Level Agreement:

Successful bidder shall sign the service level agreement (SLA) signed on bond paper (Rs 20 /-) as per annexure to be submitted before commencement of work in the format enclosed in Annexure – III.

**19. CONFIRMATION OF COMPLIANCE TO THE TENDER
REQUIREMENTS**

(To be submitted along with the Offer)

No.	Description	Yes/No	Remarks
	The proposed Technical support and Maintenance of Mail and Proxy solution shall have the following feature		
1.	System monitoring for Mail and Proxy solutions		
2.	Reporting of the activities related to Mail & Proxy maintenance		
3.	Onsite maintenance support for one year		
4.	Total scope given in this specification is understood and considered in this offer		
5.	All tender terms & conditions in total are met		
6.	Supporting documents with respect to the Resident engineer as per Scope of Work.		

Signed By:

Name: _____

Designation: _____

Organization: _____

Date & Place: _____

Phone/Fax/Mobile/Email: _____

Stamp & Seal: _____

THIRD PARTY NON-DISCLOSURE AGREEMENT

I, _____, on behalf of the _____ (Name of Company), acknowledge that the information received or generated, directly or indirectly, while working with BHEL on contract is confidential and that the nature of the business of the BHEL is such that the following conditions are reasonable, and therefore:

I warrant and agree as follows:

I, or any other personnel employed or engaged by our company, agree not to disclose, directly or indirectly, any information related to the BHEL. Without restricting the generality of the foregoing, it is agreed that we will not disclose such information consisting but not necessarily limited to:

- Technical information: Methods, drawings, processes, formulae, compositions, systems, techniques, inventions, computer programs/data/configuration and research projects.
- Business information: Customer lists, project schedules, pricing data, estimates, financial or marketing data,

On conclusion of contract, I, or any other personnel employed or engaged by our company shall return to BHEL all documents and property of BHEL, including but not necessarily limited to: drawings, blueprints, reports, manuals, computer programs/data/configuration, and all other materials and all copies thereof relating in any way to BHEL's business, or in any way obtained by me during the course of contract. I further agree that I, or any others employed or engaged by our company shall not retain copies, notes or abstracts of the foregoing.

This obligation of confidence shall continue after the conclusion of the contract also.

I acknowledge that the aforesaid restrictions are necessary and fundamental to the business of the BHEL, and are reasonable given the nature of the business carried on by the BHEL. I agree that this agreement shall be governed by and construed in accordance with the laws of country.

I enter into this agreement totally voluntarily, with full knowledge of its meaning, and without duress.

I will abide by the ISMS manual of BHEL, Ranipet.

Dated at _____, this ____ day of _____, 20__.

Name

Company

Signature

Contract Ref:

Agreement for Email and Proxy support and maintenance at BHEL, Ranipet

This agreement made on this ----- day of ----- 2015 between M/s -----, incorporated under Companies Act, 1956 and having its Registered office at ----- (hereinafter called the 'Company' which expression shall, unless it be repugnant to the context or meaning thereof, mean and include its successors and assignees) of the one part, and the BHARAT HEAVY ELECTRICALS LTD, Ranipet – 632406, incorporated under the Companies Act, 1956 and having its Registered Office at BHEL House, Siri Fort, New Delhi (hereinafter called the 'BHEL' which expression shall, unless repugnant to the context or meaning thereof, mean and include its successors and assignees) of the other part.

Whereas 'Company' is in the business of Email and Proxy support and maintenance and whereas the 'BHEL' has placed an order on Company for Email and Proxy support and maintenance at BHEL Ranipet as per the Contract (No: -----) and 'Company' has agreed to provide One Resident Engineer for Email and Proxy support and maintenance to the 'BHEL' under the following terms and conditions.

Now, therefore, the agreement witnesseth as follows:

CONTRACT REFERENCE:

1. This Document shall be read along with the Contract '_____'. The Terms & Conditions of the Contract shall be fulfilled along with the clauses of this agreement.

SCOPE of CONTRACT (in Brief):

2. 'Company' will provide **One Resident Engineer for Email and Proxy support and maintenance at BHEL Ranipet** in consideration of the Payment as per Terms and Conditions of the Contract.

3. **DEFINITIONS:**

The following expressions herein used shall, unless repugnant to the subject or context thereof, carry the meaning hereunder respectively assigned to them namely
'CONTRACT' means the Contract referred in the Clause 1.0.

4. **Email and Proxy support and maintenance:**

- 4.1 Email and Proxy solution support and maintenance shall be deployed to keep the mail and proxy solutions available without any interruption during the period of Contract.
- 4.2 The 'Company' will station one Linux certified and experienced (minimum one year) Engineer at BHEL site during contract period, for upkeep and maintenance of the email and proxy systems. The engineer should come in general shift (8:00 AM to 4:30 PM) and shall be available on call basis round the clock, to meet any exigency.
- 4.3 'Company' shall arrange a system for registration, monitoring and redress of all complaints during the contract period.
- 4.4 The 'Company' has to follow all statutory requirements like **PF, ESI** throughout the contract period. The 'Company' has to remit the P.F & ESI contribution in their own code and BHEL will not allot sub code.

5. **PAYMENT TERMS:**

5.1 The payment will be made quarterly in arrears and after receipt of invoice and duly certified by Informatics Centre, BHEL.

6. TERMINATION AND FORE-CLOSURE:

6.1 Termination: 'BHEL' reserves the right to terminate the order/contract, upon situations arising due to non-compliance of contract Terms and conditions or non-performance of the manpower continuously for more than one month.

On termination of the 'Contract', no payment shall be payable to 'Company' for the remaining period from the date of Termination.

7. CONFIDENTIALITY:

7.1 'Company' and its representatives shall, at all times, maintain complete confidentiality of all data, information, software, drawings and documents, etc. belonging to 'BHEL' and also of the systems, procedures, reports, input documents, manuals, results and any other documents discussed and/or finalized during the course of execution of the 'contract'.

7.2 The successful bidder should execute a Non-Disclosure Agreement as given in the BHEL format.

8. ARBITRATION:

8.1 In all cases of disputes emanating from and in reference to this agreement the matter shall be referred to the sole arbitration of the Head of the Unit of BHEL, Ranipet or any other person (including an employee of BHEL, even though he had to deal with the matter relating to this agreement in any manner) nominated by the said Head of the Unit to act as sole arbitrator. The arbitration shall be under 'THE ARBITRATION AND CONCILIATION ACT OF 1996' and the rules thereunder. The arbitrator may from time to times with the consent of the parties enlarge the time for making and publishing the award. The decision of the sole arbitrator is binding on both the parties.

9. JURISDICTION & GOVERNING LAWS:

9.1 In case of any suit or other legal proceedings arising under this contract the courts at Ranipet (Vellore District) Tamil Nadu only shall have the jurisdiction. This contract will be governed in all respects by India Laws.

9.2 This agreement and any amendments thereto shall be valid and binding upon 'Company' only if signed by the Authorized signatories of both 'BHEL' and 'Company'.

10. ENTIRE CONTRACT:

10.1 The Contract No: () forms part of this agreement along with the references mentioned therein.

10.2 This agreement and any amendments thereto shall be valid and binding upon 'Company' only if signed by the Authorized signatories of both 'BHEL' and 'Company'.

IN WITNESS WHEREOF, 'BHEL' has caused this agreement to be signed at Ranipet, the day and year first above written, while 'Company' has caused this agreement to be signed at _____ through its authorized signatory – under their stamp who are the only constituted attorneys for this purpose, the day and year indicated below against the execution on its behalf.

SIGNED AND DELIVERED FOR & on behalf of the above named 'Company' by its authorized representative:

At Ranipet this day of 2015.



ACCEPTANCE FOR ELECTRONIC FUND TRANSFER / RTGS TRANSFER

01	NAME & ADDRESS OF THE SUPPLIER / VENDOR	
02	VENDOR CODE (as in WORK ORDER)	
03	Details of Bank Account:	
A)	NAME & ADDRESS OF THE BANK (WITH PIN CODE)	
B)	BANK TELEPHONE NUMBER (WITH STD CODE)	
C)	<u>BANK BRANCH CODE</u>	
D)	MICR CODE	
E)	ACCOUNT NUMBER	
F)	TYPE OF ACCOUNT	CURRENT A/C / OD / CASH CREDIT
G)	VENDOR NAME AS PER BANK RECORDS	
H)	BANK BRANCH RTGS IFSC CODE	
I)	BANK BRANCH NEFT IFSC CODE	
J)	VENDOR'S E-MAIL ID (give two ids)	
K)	NAME OF AUTHORISED SIGNATORY	

CERTIFICATE

I /We hereby agree to receive the payments due from BHARAT HEAVY ELECTRICALS LIMITED, RANIPET by the National Electronic Funds Transfer and/or RTGS Transfer mode by credit to my / our above mentioned Bank Account. I / We also agree that payments made to the above mentioned Account is a valid discharge of the liability of Bharat Heavy Electricals Limited, Ranipet. I / We also agree to bear the applicable Bank Charges for the above mode of transfer.

AUTHORISED SIGNATORY OF VENDOR WITH SEAL

Banker's Certification

We confirm that we are enabled for receiving RTGS and NEFT credits and we further confirm that the account number of _____ (name of account holder), the signature of the authorized signatory and the MICR and IFSC codes of our Branch mentioned above are correct.

PLACE:

(Manager / Officer's

DATE:

Signature Under Bank stamp)
Authorisation No. _____

Note: This EFT Form is to be submitted duly filled in manually in all fields and **duly signed by Authorised Signatory and certified by Banker.**

Price Bid

Sl No	Description	Basic Price in Rs.	Applicable Tax (in %)	Tax Amount in Rs.	Total Amount in Rs.
1	Mailing & Proxy Solution Support for 1 Year: Resident Engineer at BHEL for L1-L2 Issues and Professional Support (L3 & Above Issues)				
GRAND TOTAL					

CONFIRMATION OF NOT BLACK LISTED

With reference to the above tender we confirm that we have not been under hold or delist or banned by any of BHEL unit as on bid opening date for email and proxy solutions support and maintenance.

Signed By:

Name: _____

Designation: _____

Organization: _____

Date & Place: _____

Phone/Fax/Mobile/Email: _____

Stamp & Seal: _____

Place:

Date:

CONFIRMATION OF NOT BANKRUPTED

With reference to the above tender we confirm that we have not been involved in any bankruptcy issues as on bid opening date for email and proxy solutions support and maintenance.

Signed By:

Name: _____

Designation: _____

Organization: _____

Date & Place: _____

Phone/Fax/Mobile/Email: _____

Stamp & Seal: _____

Place:

Date: