



**Bharat Heavy Electricals Limited**  
**(Seamless steel Tube Plant)**  
Tiruchirappalli – 620014, TAMIL NADU, INDIA

|  |   |
|--|---|
| <b>TITLE:</b><br><b>SUPPLY OF CONNECTING ROD,LINER &amp; BLAST RING- 6 Items</b> | Phone: +91 431 257 8439<br>Email : pcsn@bheltry.co.in<br>Web : <a href="http://www.bhel.com">www.bhel.com</a> |
|--|---|

|                                   |                         |   |
|-----------------------------------|-------------------------|---|
| <b>Reference Number: 9440708E</b> | <b>Date: 11.07.2014</b> | <b>Due date for submission of application: 01.08.2014</b> |
|-----------------------------------|-------------------------|---|

**BHEL/SSTP, Trichy is looking for vendors to supply of CONNECTING ROD,LINER & BLAST RING- 6 Items as per Tender documents attached.**

**A. Important Note to New Vendors (Viewers thro' web site)**

The new vendors will be required to furnish the following documentary proof/ information along with their offers:

1. Certificate of registration (copy of certificate to be submitted).
2. Banker's information (copy of bank pass book first page to be submitted).
3. MSME vendor certificate (if applicable).
4. Address of your organization (complete postal address with PINCODE).
5. Contact person's Phone No. /Mobile No. / FAX No. /E-mail ID.
6. Statutory documents – VAT / TIN / EXCISE REGISTRATION / CST REGN / SERVICE TAX REGISTRATION etc. (copy to be furnished)
7. NSIC/SSI Certificate (if applicable)
8. ISO Certificate (if applicable)
9. Experience certificate as proof of supply of similar items to any Govt. agencies / PSU / Organisations (copy of PO's to be furnished).
10. Audit Report/ IT Return (if applicable)
11. Agency agreement with manufacturer (if applicable)
12. Partnership Deed (if applicable).

**If the new vendors fail to submit the above documentary proof/information, their offers will not be considered for this enquiry.**

Purchase Officer / Purchase /SSTP  
Phone: 0431-257 8439.  
Mail: pcsn@bheltry.co.in



**BHARAT HEAVY ELECTRICALS LIMITED**  
(A GOVERNMENT OF INDIA UNDERTAKING)  
SEAMLESS STEEL TUBE PLANT  
TIRUCHIRAPALLI - 620 014.  
TAMILNADU (INDIA)

PHONE : 0431-2578480/8491  
: 0431-2578406/8419  
: 0431-2578568  
FAX : 0431-2576828

TIN : 33243560005  
CST. No. : 239383  
Dated : 11.06.1991

Corp. Identity No:  
L74899DL1964GOI004281

**PURCHASE ENQUIRY**

VENDOR CODE  
20089

ENQUIRY NUMBER  
9440708E

ENQUIRY DATE  
11/07/2014

ENQUIRY DUE DATE  
01/08/2014

No. OF ITEMS  
06

Office Copy

**IMPORTANT POINTS :**

1. Tender Closing Time : 14.00 Hrs.
2. Tender Opening Time : 15.00 Hrs.
3. Tender should be submitted in a sealed cover, duly indicating enquiry No. Enquiry date & Enquiry Due Date on the cover.
4. Offer(s) received through Courier Services after 14.00 Hrs. on Enquiry Due Date will not be considered.
5. Late Tender(s) is/are liable for rejection.
6. Offer(s) shall be valid for 60 days from Enquiry Due Date.
7. Offer(s) in Vendor's Letter head shall contain.
  - a. Offer No. and Date
  - b. Delivery Period
  - c. Delivery Terms
  - d. Payment Terms
  - e. Excise Duty with Tariff Heading Sales Tax (against form-XVII/Form-C). etc.
  - f. Excise Regn. No. and SSI Regn. No.

Kindly arrange to submit your COMPETITIVE OFFER for the following item(s)  
If you are not in a position to submit your Offer, kindly arrange to send your REGRET LETTER.

**THIS IS ONLY A REQUEST FOR OFFER AND NOT AN ORDER**

| Sl.No. | BHEL Material Code and Description  | Unit | Requirement |            |
|--------|---|------|-------------|------------|
|        |   |      | Quantity    | Delivery   |
| 01     | BHEL Material Code : SP9112402023<br>-----<br>CONNECTING ROD<br>DRG.NO.4-9-1124-02-00074<br>MATL:C45<br>EDIT DRG.NO:3-7-1124-22-10196 | Nos. | 01 2.000    | 13/08/2014 |
| 02     | BHEL Material Code : SP9112402131<br>-----<br>LINER(1)<br>DRG.NO.4-9-1124-02-00077<br>MATL:45 C8                                      | Nos. | 01 6.000    | 13/08/2014 |
| 03     | BHEL Material Code : SP9112402134<br>-----<br>LINER(2)<br>DRG.NO.4-9-1124-02-00078<br>MATL:C45  | Nos. | 01 6.000    | 13/08/2014 |
| 04     | BHEL Material Code : SP9112404109<br>-----<br>ROLLER<br>DRG.NO.4-9-1124-04-00082<br>MATL:45 C8  | Nos. | 01 4.000    | 13/08/2014 |
| 05     | BHEL Material Code : SP9112403001<br>-----<br>SHAFT<br>DRG.NO.3-7-1124-23-10160<br>MATL:45 C8 IS:1875                                 | Nos. | 01 2.000    | 13/08/2014 |

**IMPORTANT NOTE :**

1. Delivery Terms : "Free Delivery at BHEL-SSTP STORES" is preferable.
2. Payment Terms : 100% payment after 45 days after receipt and acceptance of materials by BHEL.
3. Terms and Conditions of Tender : Please see reverse.
4. The Technical Requirements/Specification Details/Quality Requirements/Commercial Terms & Conditions are clearly furnished in the Tender. If Deviation(s) is/are not explicitly brought out in the Offer, it will be construed that the Tenderer is complying with the requirement of BHEL in full without any deviation(s).

For and on behalf of

**BHARAT HEAVY ELECTRICALS LTD.**

**PURCHASE EXECUTIVE**



**BHARAT HEAVY ELECTRICALS LIMITED**  
 (A GOVERNMENT OF INDIA UNDERTAKING)  
**SEAMLESS STEEL TUBE PLANT**  
 TIRUCHIRAPALLI - 620 014.  
 TAMILNADU (INDIA)

PHONE : 0431-2578480/8491  
 : 0431-2578406/8419  
 : 0431-2578568  
 FAX : 0431-2576828

TIN : 33243560005  
 CST. No. : 239383  
 Dated : 11.06.1991

Corp. Identity No:  
 L74899DL1964GOI004281

**PURCHASE ENQUIRY**

|                      |                            |                            |                                |                    |
|----------------------|----------------------------|----------------------------|--------------------------------|--------------------|
| VENDOR CODE<br>20089 | ENQUIRY NUMBER<br>9440708E | ENQUIRY DATE<br>11/07/2014 | ENQUIRY DUE DATE<br>01/08/2014 | No. OF ITEMS<br>06 |
|----------------------|----------------------------|----------------------------|--------------------------------|--------------------|

Office Copy

- IMPORTANT POINTS :**
1. Tender Closing Time : 14.00 Hrs.
  2. Tender Opening Time : 15.00 Hrs.
  3. Tender should be submitted in a sealed cover, duly indicating enquiry No. Enquiry date & Enquiry Due Date on the cover.
  4. Offer(s) received through Courier Services after 14.00 Hrs. on Enquiry Due Date will not be considered.
  5. Late Tender(s) is/are liable for rejection.
  6. Offer(s) shall be valid for 60 days from Enquiry Due Date.
  7. Offer(s) in Vendor's Letter head shall contain.
    - a. Offer No. and Date
    - b. Delivery Period
    - c. Delivery Terms
    - d. Payment Terms
    - e. Excise Duty with Tariff Heading Sales Tax (against form-XVII/Form-C). etc.
    - f. Excise Regn. No. and SSI Regn. No.

Kindly arrange to submit your COMPETITIVE OFFER for the following item(s)  
 If you are not in a position to submit your Offer, kindly arrange to send your REGRET LETTER.

**THIS IS ONLY A REQUEST FOR OFFER AND NOT AN ORDER**

| Sl.No.   | BHEL Material Code and Description   | Unit | Requirement |            |
|--|--|------|-------------|------------|
|  |  |      | Quantity    | Delivery   |
| 06   | <b>BHEL Material Code : SP9112799011</b><br><hr/> BLAST RING<br>FOR PUSHER ROD COOLING<br>DRG NO : 2-7-1127-04-01098<br>MATERIAL : Fe410WA,IS:2062 & SA192 | Nos. | 01 4.000    | 15/09/2014 |
| <p><b>Foot Note ::</b></p> <p>THIS TENDER IS CALLED ON TWO BID SYSTEM.KINDLY REFER THE ANNEXURE-A,B,C &amp; D ATTACHED.</p> <p>CONFIRM THE FOLLOWING COMMERCIAL POINTS WITHOUT FAIL:</p> <ol style="list-style-type: none"> <li>1.OUR STD PAYMENT TERMS IS 100 % PYT WILL BE MADE AFTER 45 DAYS ON RECEIPT AND ACCEPTANCE OF MATERIALS THRO E-PAYMENT.FORMAT WILL BE SENT ALONG WITH PUR ORDER.</li> <li>2.INSPECTION WILL BE CARRIED OUT AT YR WORKS PRIOR TO DESPATCH BY BHEL.FOR WHICH ONE WEEK ADVANCE INTIMATION IS TO BE GIVEN ON READINESS OF MATERIAL.</li> <li>3.PL QUOTE THE RATE ON DOOR DELIVERY BASIS DULY INCLUDING PKG,FORWARDING, FREIGHT AND INSURANCE CHARGES.</li> <li>4.TEST AND GUARANTEE CERTIFICATES ARE TO BE SUBMITTED ALONG WITH SUPPLIES.</li> <li>5.PERFORMANCE BANK GUARANTEE FOR 10 % ON BASIC VALUE IS TO BE SUBMITTED WHILE RELEASING PAYMENT.</li> <li>6.CONFIRM YR ACCEPTANCE FOR LD AND RISK PURCHASE CLAUSES.</li> </ol> |  |      |             |            |
| <p>Indent Details</p> <hr/>  |  |      |             |            |

**IMPORTANT NOTE :**

1. Delivery Terms : "Free Delivery at BHEL-SSTP STORES" is preferable.
2. Payment Terms : 100% payment after 45 days after receipt and acceptance of materials by BHEL.
3. Terms and Conditions of Tender : Please see reverse.
4. The Technical Requirements/Specification Details/Quality Requirements/Commercial Terms & Conditions are clearly furnished in the Tender. If Deviation(s) is/are not explicitly brought out in the Offer, it will be construed that the Tenderer is complying with the requirement of BHEL in full without any deviation(s).

For and on behalf of  
**BHARAT HEAVY ELECTRICALS LTD.**

*(Signature)*  
**PURCHASE EXECUTIVE**

## TERMS AND CONDITIONS OF ENQUIRY

### 01. OFFER

01.

Each Tender shall be sent in double cover. Inner cover shall be sealed with Tenderer's distinctive seal and superscribed with correct Enquiry No. and Enquiry Due Date. The Outer cover shall only bear the address of this Office and shall not have any indication that a Tender is within. more Offers shall not be sent in one cover but the Offer against each Enquiry shall be sent separately to avoid confusion. Tender shall be addressed to any individual's name but only by Designation.

02.

Tenders shall be free from CORRECTION AND ERASURES. Corrections, if any, must be attested. All amounts shall be indicated both in words and in figures. Where there is difference between the amount quoted in words and figures, amount quoted in words shall prevail.

03.

Rate(s) shall be net F.O.R./BHEL-SSTP STORES, inclusive of risk-in transit and remain valid for 60 days from the Enquiry Due/other Taxes/Duties.

04.

If any Sales Tax and /or Excise Duty and /or other Taxes/Duties is /are payable as extra to the quoted Rate, it shall be specifically stated in offer, failing which the Purchaser will not be liable for payment of Sales/Excise Duty/other Taxes/Duties.

05.

No voluntary revision of prices will be entertained after opening the Tender(s).

06.

Manufacturer's Name, Trade Mark or Patent No., if any, shall be specified. Illustrative leaflets giving technical particulars are required along with the tender wherever necessary.

07. Products with I.S.I. Certification Marks will be preferred.

08.

The Purchaser shall be under no obligation to accept the Lowest Tender or any other Tender. The Purchaser shall be entitled to accept or reject any tender in part or full, without assigning any reason whatsoever.

09.

The Purchaser also reserves the right to allow the Purchase Preference Facilities to the Public Enterprises, as admissible under Government Policies and Amendments thereto from time to time.

10.

BHEL reserves the right to increase or decrease the Tender Quantity and split the Tender Quantity among more than one Tenderer and place the order accordingly in proportion, based on commitment, requirement and Supplier's capability in terms of delivery and quality.

11.

Lowest Rate received against Tender(s) need not be the technically acceptable L-1 Rate and BHEL reserves the right not to consider the same.

12.

BHEL reserves the right to negotiate or re-float the opened Tender, if L-1 Rate is not the lowest acceptable rate to them, inter-alia other reasons.

13.

BHEL reserves the right to negotiate the L-1 rate.

14.

BHEL may order on more than one Vendor at the lowest acceptable Rate.

02.

**SAMPLES:** Wherever possible, samples shall be submitted separately whether specifically requested or not, so as to reach the Purchaser on or before the Enquiry Due Date. They shall be clearly marked with the Enquiry No. and Enquiry Date, on the cover to facilitate identification.

03.

**PACKING AND MARKING:** The Seller shall arrange for securely protecting and packing the stores to avoid loss or damage during transit.

04.

**TERMS OF PAYMENT:** 100% Payment will be made after 45 days of receipt and acceptance of materials at BHEL. Wherever required by the Purchaser, the successful Tenderer shall send the operation and maintenance Manual(s), Test Certificate(s), Drawing(s) etc., for the materials ordered, along with the materials and statement to that effect. Payment shall be made in the Invoice. Failure to comply with this provision, will result in delay in payment of the bill(s). Goods despatched either by V.P.R. or routing the documents to the Bank, will not be accepted unless agreed to by the Purchaser.

05.

**SECURITY EPOSIT:** For Purchase over Rs. 5000.00 the successful Tenderer or may be required to furnish a Bank Guarantee/Security Deposit for an appropriate value determined by BHEL, through any of the Nationalised Bank/Scheduled Banks, Who is a member-Bank in BHEL's consortium of Banks, which will be intimated along with Purchase Order, at the discretion of BHEL.

06.

**LIQUIDATED DAMAGES:** It is clearly understood among the parties to the contract that TIME IS THE ESSENCE OF THE CONTRACT. Therefore the delivery of the goods specified in the Purchase order shall be made within the time prescribed. Where the seller supplies or despatches the goods. Beyond the delivery period specified, and the Purchaser will have no obligation to accept the goods. If accepted, Liquidated Damages at the rate of 0.5% (zero point five percent) of the value of goods delayed, per week or month, subject to a maximum of 10% (Ten percent) or part thereof, will be levied without prejudice to any other relief or compensation due to the Purchaser under any conditions of the contract.

07.

**RISK PURCHASE:** Alternatively, the Purchaser, at his option, will be entitled to terminate the Contract and to purchase elsewhere at the risk and cost of Seller, the whole of the goods or any part, which the Seller has failed to deliver or despatch within the time stipulated as aforesaid or if the same were not available, the best and nearest available substitute thereof. The Seller shall be liable for any loss, Which the Purchaser may sustain by reason of such purchase(s), in addition to penalty at the rate mentioned in Clause No. 06 above.

08.

**PREFERENTIAL DELIVERY:** In case of failure to complete supplies, in terms of such Contract within the date of delivery specified in the Tender and incorporated in the Contract, it shall be noted that in the event of an Order is placed on a higher Tenderer as result of this invitation of Tender, in preference to the lowest acceptable Offer in consideration of the earlier delivery, the Seller will be liable to pay to the Purchaser the difference between the Contract Rate and the lowest acceptable Tender on the basis of final price. (F.O.R./BHEL-SSTP Stores) including all elements of Freight, Sales Tax, Duty(s) and other incidentals.

09.

### **GUARANTEE:**

01.

In the event of an Order, the materials notified in the Order shall be guaranteed for satisfactory performance against all manufacturing defects, faulty design and bad-workmanship, etc. The liability under Seller's Guarantee Certificate shall cover a total period of 18 (Eighteen) Months from the date of despatch of the material(s) whichever is earlier. A Guarantee Certificate to the above effect shall accompany the despatch documents. In case of staggered delivery, the Guarantee Certificate shall accompany the despatch documents each time.

02.

**Performance Bank Guarantee:** Wherever required, BHEL shall request the successful Tenderer to execute a Performance Bank Guarantee, covering the standard Guarantee Terms of BHEL, through any of the Nationalised Banks / Scheduled Banks, who is a Member-Bank in BHEL's Consortium of Banks, which will be intimated along with Purchase Order, at the discretion of BHEL.

10.

### **CENVAT CREDIT:**

01.

Please explicitly indicate the following in the Offer to enable us to avail CENVAT Credit.

01.

Excise Registration Number, Excise Control Code (ECC) Number,

02.

Central Excise Chapter Heading Number, Under which the goods will be cleared,

03.

Present Rate of Excise Duty.

02.

In the event of an Order being placed, Excise Duty will be reimbursed only based on the Duplicate Copy EXCISE INVOICE (Transporter's Copy), Seller shall take acknowledgement from the authorised personnel/transporter, while delivering the goods, for having handed over the above Duplicate Copy.

03.

If the Seller is a First Stage Dealer / Second Stage Dealer / Depot / Consignment Agent / Importer / Importer- Agent, the Seller has to confirm that they will be following the procedures in terms of the provisions of Central Excise Rules-2002, to enable BHEL to avail CENVAT Credit, under CENVAT Credit Rules-2002.

04.

All the time of submission of invoice(s), the Seller is required to furnish the following Certificate.

"The Amount of Rs. (Rupees in words.....) claimed as CENVAT in the Bill.

is in accordance with the provisions of the Rules in all respects and that the same has

been paid to the Central Excise Authorities in respect of the materials covered by the Bill".

11.

**GENERAL:** Any other conditions which might have been quoted by the Seller and are in contravention to the Terms prescribed in the Tender/Order and which have not been specifically accepted by the Purchaser, will not be applicable to the Contract and BHEL's standard Terms & Conditions shall only be applicable.

12.

### **IMPORTANT NOTE:**

01.

Purchaser reserves the right to place Repeat Order(s) at the same Price and Terms & Condition, within 36 (Thirty Six Months) from the date of completion of supply, whichever is earlier. A specific confirmation in the regard shall only be applicable.

02.

In the event of quoting "Packing and Forwarding charges" extra in the offer, the "Packing Charges" and "Forwarding Charges" shall be separately quoted and shall not be combined. Also please note that no Excise Duty and sales Tax shall be payable on Forwarding Charges. In case this is not complied with corresponding Excise Duty and Sales Tax on packing Charges will not be paid.

03.

In the event of the Tenderer being a S.S.I. Unit, the tenderer shall indicate the S.S.I.Reg. No. in the Offer and also enclose a copy of S.S.I.Reg. Certificate issued by the Competent Authority.

04.

Tenderer is requested to furnish all the details called for in the Tender. In case any required data/information is/ are not furnished in the offer, Purchaser reserves the right to assume the same for the purpose of evaluation/comparison and decide the Tender accordingly.

**Respective procurement Groups shall incorporate the applicable conditions in the NIT for Indigenous and Imports separately.**

| <b>Payment Term (Indigenous)</b>  |   |
|---|---|
| <b>If materials are receivable at Stores/Trichy <u>without PBG</u></b>  | Payment term is 100% direct payment after 45 days from the date of receipt and acceptance of materials.   |
| <b>If materials are receivable at Stores/Trichy <u>with PBG</u></b>   | Payment term is 100% direct payment after 45 days from the date of receipt and acceptance of materials and against 10% PBG valid for the warranty period. |
| <b>Any deviation in the above payment term will attract loading as mentioned below. “Base rate of SBI (as applicable on the date of bid opening. Techno-commercial bid opening in case of two part bids) + 6% shall be considered for loading for the period of relaxation sought by bidders.</b> |   |

| <b>Payment Term (Indigenous)</b>                                       |  |
|--|--|
| <b>If materials are receivable at Project Sites <u>without PBG</u></b> | <b><u>Option-1:</u></b> Payment term is 100% direct payment after 45 days from the date of dispatch against site acknowledgement<br><b><u>Option-2:</u></b> Payment term is 90% direct payment after 45 days from the date of dispatch against submission of dispatch documents and balance 10% against site acknowledgement. <b>For this option -2, a loading of 2% on the 90% of the offered value shall be made.</b>  |
| <b>If materials are receivable at Project Sites <u>with PBG</u></b>    | <b><u>Option-1:</u></b> Payment term is 100% direct payment after 45 days from the date of dispatch against site acknowledgement and against 10% PBG valid for the warranty period.<br><b><u>Option-2:</u></b> Payment term is 90% direct payment after 45 days from the date of dispatch against submission of dispatch documents and 10% PBG valid for the warranty period and balance 10% against site acknowledgement. <b>For this option -2, a loading of 2% on the 90% of the offered value shall be made.</b> |

|   |  |
|---|--|
| <b>To be incorporated in all NITs addressed to Indigenous Suppliers</b> | Payment through Bank is not preferred. In case of Payment through Bank is opted by Supplier, BHEL prefers documents submission through bank with copy of LR and door delivery of Goods to Site/Stores with Consignee copy attached. In this case Loading will be 3% on the offered value. In case of Direct to Site (DTS), only 90% through bank will be considered. |
|   | Offers of indigenous Suppliers with payment terms as LC/Advance Payment are liable for rejection.  |

**Payment Term (Imports) - To be incorporated in all NITs addressed to Import Suppliers**

BHEL Payment term is 100% payment on CAD basis after 45 days from the date of receipt of documents, specified in PO, at BHEL bank. Respective bank charges to respective account.

**Any deviation in the above payment term will attract loading as mentioned below. “Base rate of SBI (as applicable on the date of bid opening. Techno-commercial bid opening in case of two part bids) + 6% shall be considered for loading for the period of relaxation sought by bidders.**

- In the case of Usance LCs the loading will be considered @ 1.5% on the offered Value.**
- For LC at sight the loading will be considered @ 3.5% on the offered Value.**
- Normally CAD at sight and Confirmed LCs are liable for rejection.**

**Liquidated Damages / Penalty - To be incorporated in all NITs addressed to both Indigenous and Import Suppliers**

Liquidated damages shall be 0.5% of the total order value per week or part thereof subject to a maximum of 10% of the total order value.

For staggered delivery schedule, LD shall be 0.5% of the undelivered portion per week of the delay or part thereof subject to a maximum of 10% of the total order value.

Any deviation from the above LD clause, loading will be applied to the extent to which it is not agreed by the bidder (at offered value).

**Guarantee / Warranty Period - To be incorporated in all NITs addressed to both Indigenous and Import Suppliers**

Normally No deviation permitted and the deviated offers are liable for rejection.

**Performance Bank Guarantee - To be incorporated in all NITs addressed to both Indigenous and Import Suppliers**

Normally No deviation permitted and the deviated offers are liable for rejection.

**To be incorporated in all NITs addressed to both Indigenous and Import Suppliers**

BHEL will consider the ranking after the loading is applied as referred above wherever deviations are observed.

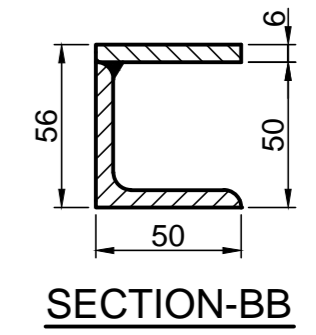
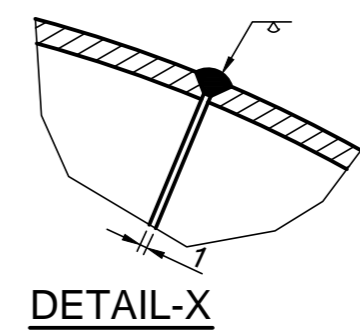
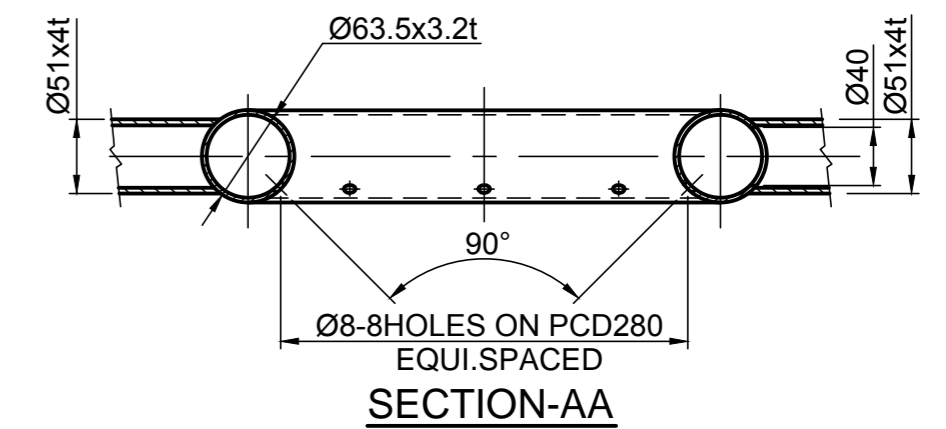
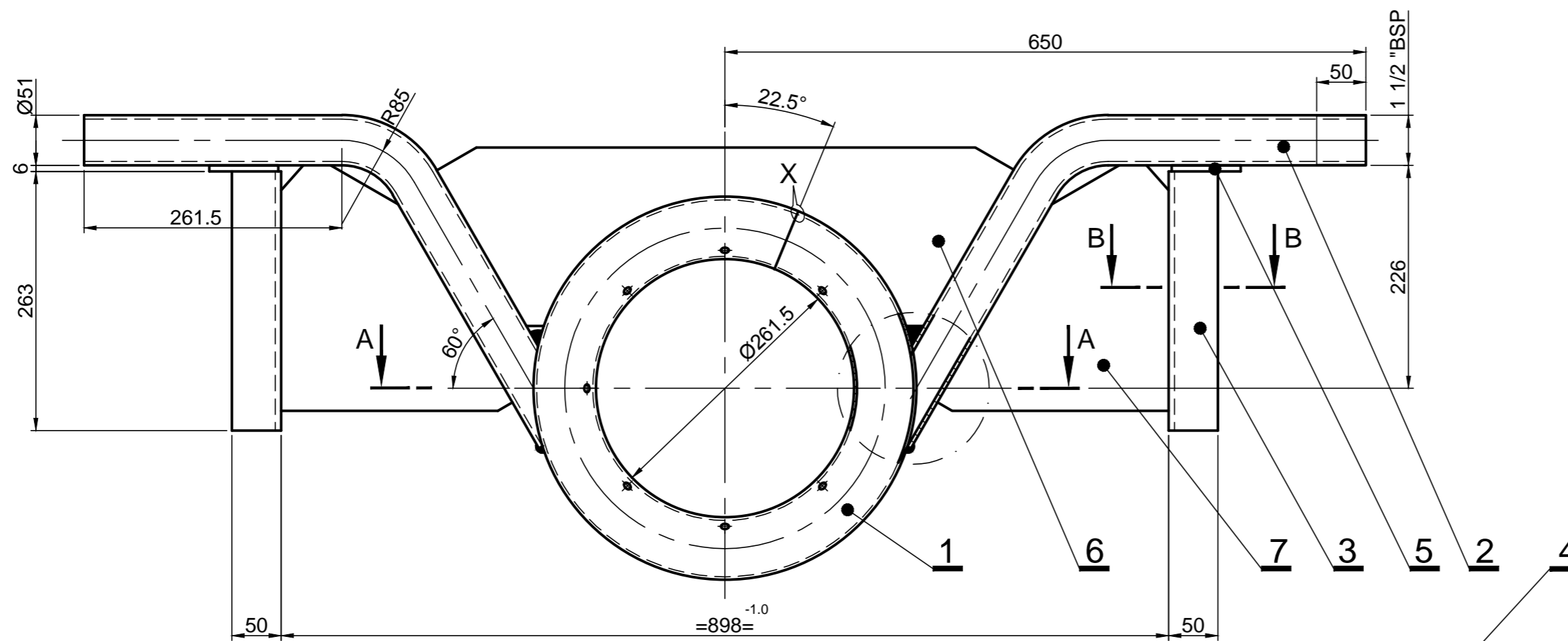

NOTES  
ALL WELDED CONSTRUCTIONS.  
FILLET SIZE 5mm.

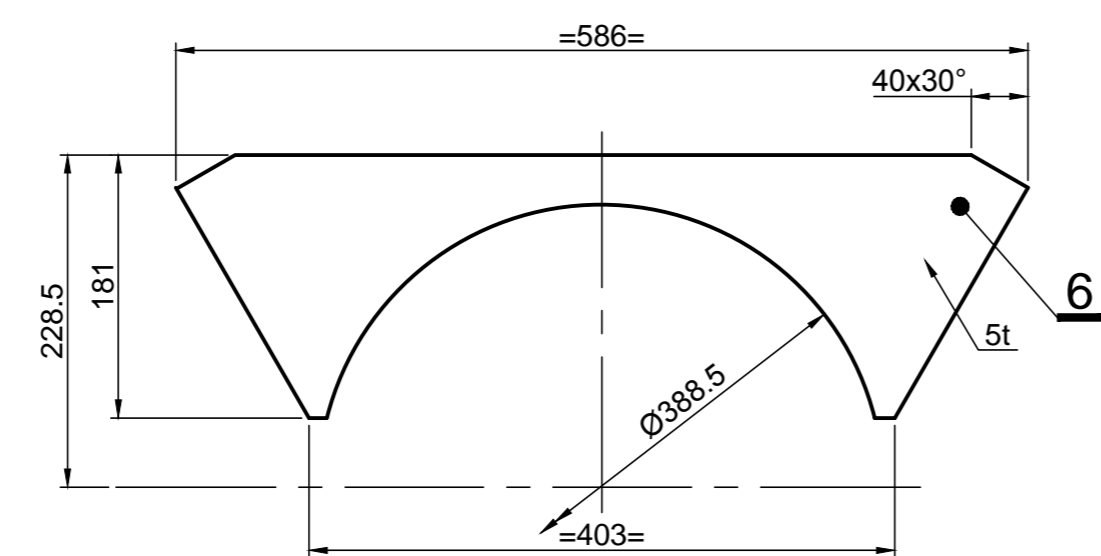
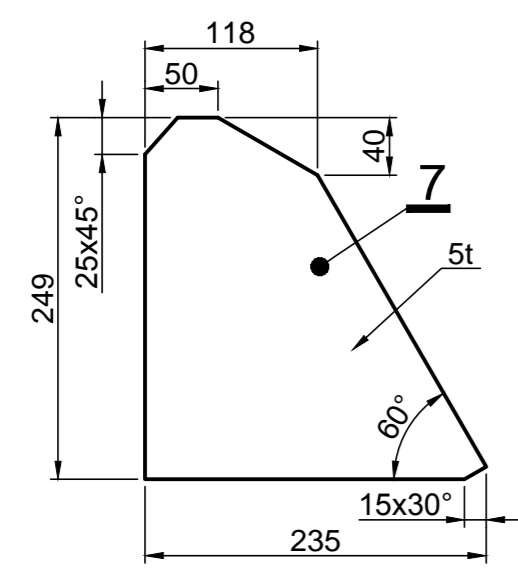
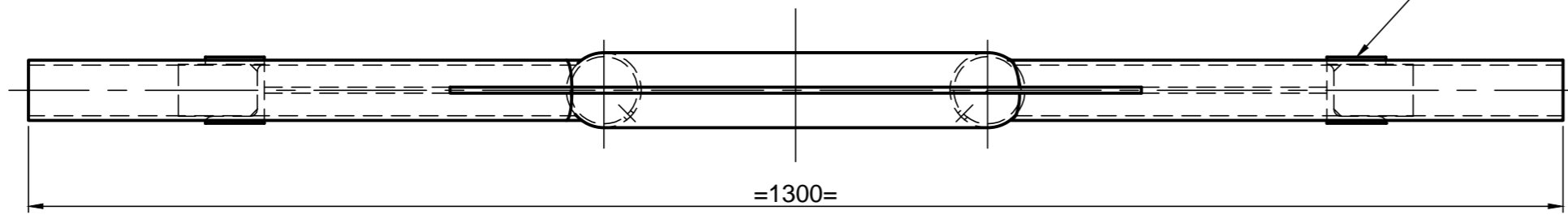

| ITEM NO | DESCRIPTION           | DRAWING NO | MATL CODE       | UNIT WT |
|---------|-----------------------|------------|-----------------|---------|
|         |                       |            | MATL SPEC       | QTY     |
| 7       | PL.5 249x235          |            | Fe410WA IS:2062 | 1.6     |
| 6       | PL.5 586x181          |            | Fe410WA IS:2062 | 1.66    |
| 5       | PL.6 70x44            |            | Fe410WA IS:2062 | 0.145   |
| 4       | PL.6 263x50           |            | Fe410WA IS:2062 | 0.62    |
| 3       | ISA50x50x6t-263L      |            | Fe410WA IS:2062 | 1.18    |
| 2       | TUBE Ø51x4t-592L      |            | SA192           | 3.09    |
| 1       | TUBE Ø63.5x3.2t-1020L |            | SA192           | 5.5     |

CAUTION: THE INFORMATION ON THIS DOCUMENT IS THE PROPERTY OF BHARAT HEAVY ELECTRICALS LIMITED. IT MUST NOT BE USED DIRECTLY OR INDIRECTLY IN ANY WAY DETRIMENTAL TO THE INTEREST OF THE COMPANY.

|                      |               |                          |   |
|----------------------|---------------|--------------------------|---|
| REV 01               | DATE 03.05.13 | ALTERED CHECKED APPROVED | S.K.K. Kumar<br>R. Raghavanan<br>S. Mohan |
| NEW BORDER INSERTED. |               |                          |   |

|                           |  |                     |          |                   |                                   |           |
|---------------------------|--|---------------------|----------|-------------------|-----------------------------------|-----------|
| DEPT SSSP                 |  | GRADE OF UNTOL. DIM | SCALE    | WEIGHT (Kg)       | REF TO ASSY DWG NO                | ITEM      |
| 456                       |  | Ø/M/Ø<br>IS: 2102   | 1: 1:2.5 | 20.43             | REF TO OLD DWG NO                 |           |
| TITLE<br>PHB - BLAST RING |  |                     |          | CARD CODE<br>U 01 | DRAWING NO :<br>2-7-1127-04-01098 | REV<br>01 |

ALL DIMENSIONS ARE IN MILLIMETRES

DRAWING NO: 3-7-1124-23-10160

|        |        |
|--------|--------|
| 22 JS9 | +0.026 |
|        | -0.026 |
| Ø45 k6 | +0.018 |
|        | +0.002 |

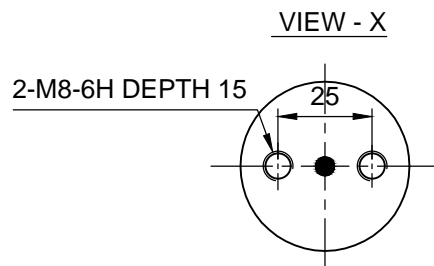
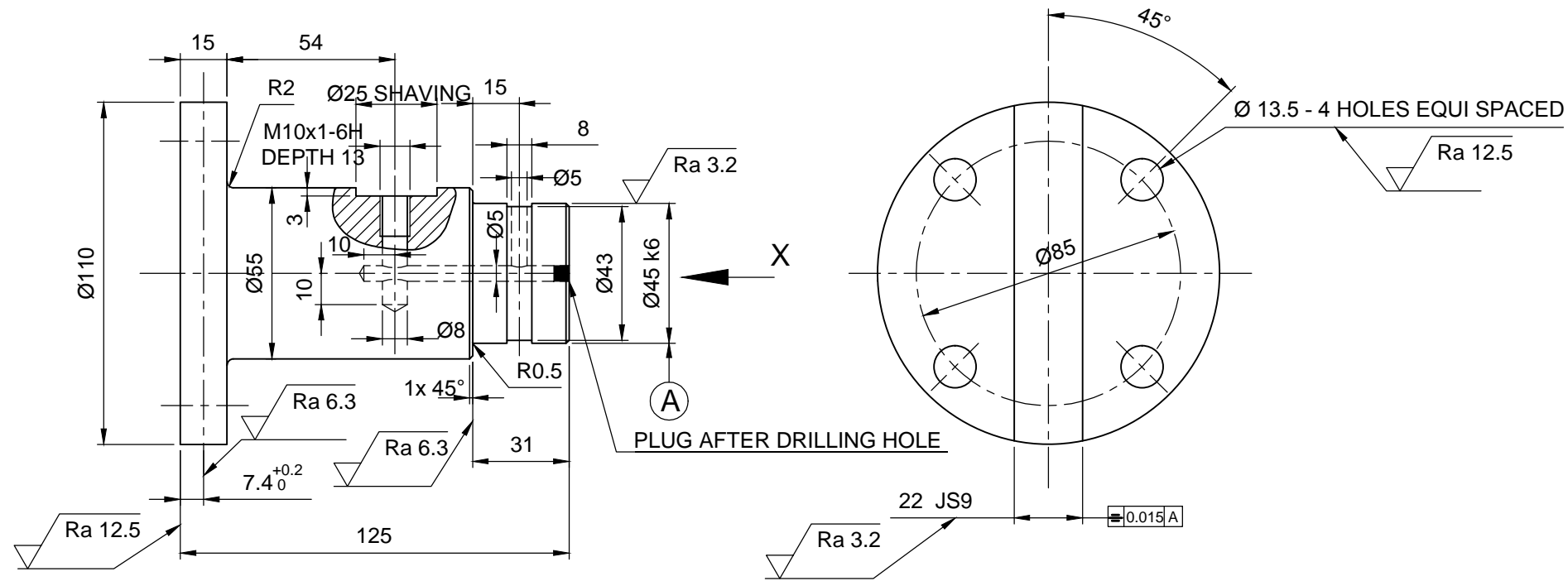

TECHNICAL REQUIREMENT  
QUENCHING AND TEMPERING  
241-269 HBW

CAUTION: THE INFORMATION ON THIS DOCUMENT IS THE PROPERTY OF BHARAT HEAVY ELECTRICALS LIMITED. IT MUST NOT BE USED DIRECTLY OR INDIRECTLY IN ANY WAY DETRIMENTAL TO THE INTEREST OF THE COMPANY.

|  |                              |                    |                 |
|--|------------------------------|--------------------|-----------------|
|  |                              | 45C8 IS:1875       |                 |
| ITEM NO  | DESCRIPTION                  | DRAWING NO         | UNIT WT         |
|  |                              | MATL SPEC          |                 |
|  |                              | QTY                |                 |
| EQPT: MANIPULATOR                                |                              |                    |                 |
|  | Bharat Heavy Electricals Ltd |                    | DRN             |
|  | SEAMLESS STEEL TUBE PLANT    |                    | NAME            |
|  | TIRUCHIRAPALLI - 620014      |                    | S.S.N.KUMAR/K.K |
|  |                              | CHD                | G.LOGANATHAN    |
|  |                              | APPD               | M.CHANDRAKUMAR  |
|  |                              | SIGNATURE          |                 |
|  |                              | S. Loganathan      |                 |
|  |                              | DATE               |                 |
|  |                              | 11.2.14            |                 |
| DEPT   | GRADE OF UNTOL. DIM          | SCALE              | WEIGHT (Kg)     |
| SSTP   | φ/M/F                        | 1:2                | 2.82            |
| CODE   | IS: 2102                     | REF TO ASSY DWG NO |                 |
| 456  |                              | TA772.03.03.00     |                 |
|  |                              | REF TO OLD DWG NO  |                 |
|  |                              | TA772.03.03.01     |                 |
| TITLE  |                              |                    | CARD CODE       |
| MPL - SHAFT FOR GUIDE WHEEL OF LIFTING RACK BEAM |                              |                    | U 01            |
| DRAWING NO :                                     |                              |                    | REV             |
| 3-7-1124-23-10160                                |                              |                    | 00              |

| REV | DATE | ALTERED  |
|-----|------|----------|
| 01  |      | CHECKED  |
|     |      | APPROVED |

TA772.02.08

other  $\frac{25}{\nabla}$

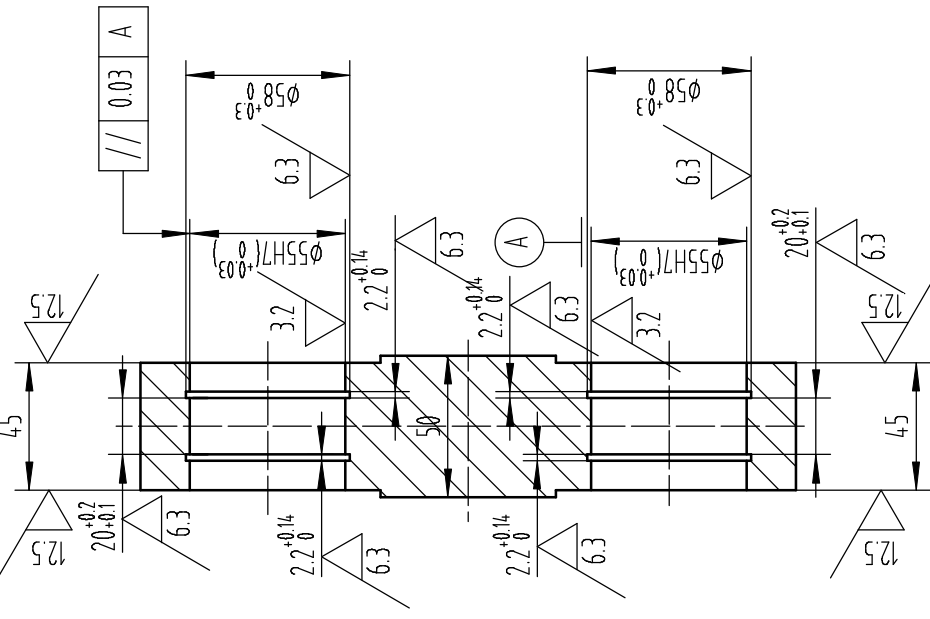
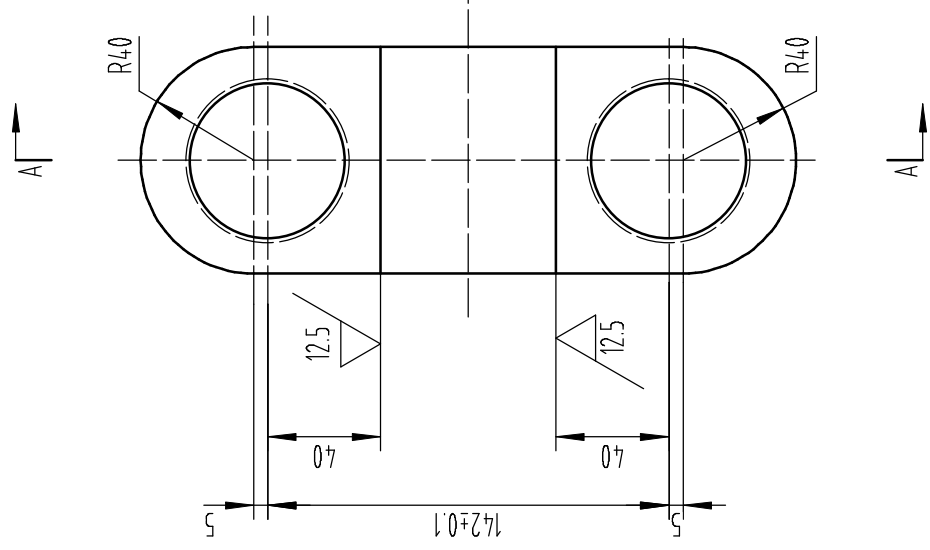

technical requirement  
 quenching and tempering 241-269  
 HBW.

|                                      |      |             |              |                                       |
|--------------------------------------|------|-------------|--------------|---------------------------------------|
| <b>TZCE</b><br>TONGZE HEAVY INDUSTRY |      | DESIGNATION | DRAWING NO.  |                                       |
| DESIGNER                             | NAME | DATE        | TA772.02.08  |                                       |
| CHECKED                              | NAME | DATE        | WEIGHT       | SCALE                                 |
| INSPECTER                            | NAME | DATE        | 4.58         | 1:2.5                                 |
|                                      | NAME | DATE        | SHEETS       | SHEET                                 |
|                                      | NAME | DATE        | ISO Method E |                                       |
|                                      | MARK | AMOUNT      | DOCUMENT NO. | NAME                                  |
|                                      |      |             |              | Universal Technical Standard JB/75000 |
|                                      |      |             |              | DATE                                  |

TA772.02.13

12.5  
other

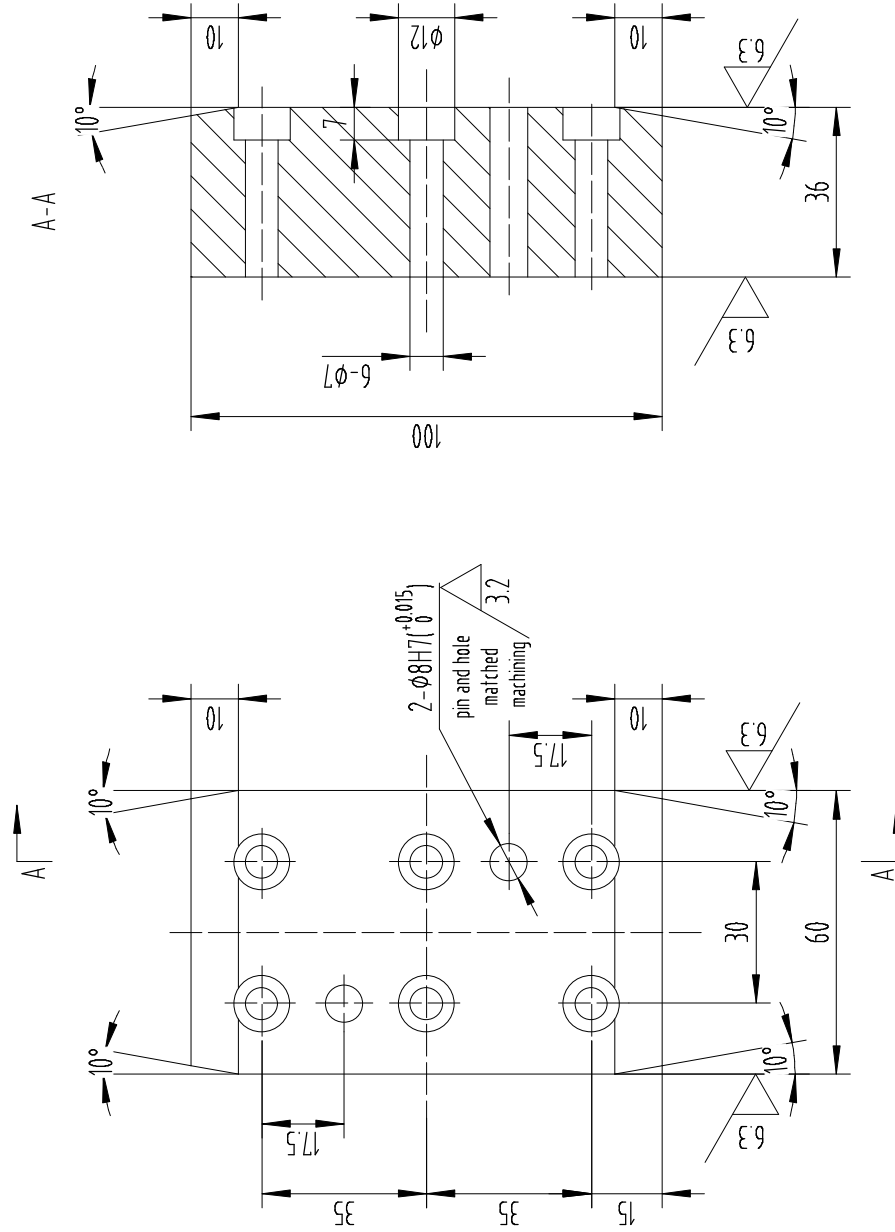

technical requirement

1. quenching and tempering  
241-269HBW;
2. break other sharp edges  
2×45°.



DESIGNATION

liner(1)

DRAWING NO.

TA772.02.13

DESIGNER

CHECKED

INSPECTOR

MATERIAL

45

WEIGHT

1.61

SHEETS

SCALE

1:1.5

SHEET

ISO Method E

NAME NAME DATE

MARK AMOUNT DOCUMENT NO. NAME DATE

Universal Technical Standard JB/75000





## ANNEXURE-A

### IMPORTANT NOTE TO TENDERERS ( FOR INDIGENOUS & OVERSEAS SUPPLIERS )

**This Tender is floated on TWO-BID System.** Tenders are requested to submit their offers in TWO-BIDS (Part I: Un priced bid and Part II: Price Bid) separately in a sealed cover as follows.

1. **Part I: UN PRICED BID:** (Complete with technical & Commercial conditions as per enquiry including un priced copy of price schedule i.e. identical to part II with prices blanked and replaced by "Quoted") .

The Tenderer should confirm their acceptance / comments to the Enquiry along with other commercial Terms & Conditions of the Tender. In case any deviation is taken by the Tenderer from the Tender requirements, it is to be clearly indicated in the offer with reference to the particular clause. If such deviations are not explicitly indicated in the offer, it will be construed by BHEL that the Tenderer is complying with Annexure Clause(s), Commercial terms & conditions and other conditions in full.

2. **Part II: PRICE BID:** Price (with break-up details wherever required) to be indicated.
3. **Both Un priced Bid and Price Bid is** to be submitted in a single envelop before 1400 hours (Indian Time) on tender Due Date.
4. The **Unpriced Bid** shall be put in a separate sealed cover superscribed with Tender number, Tender Date & Tender Due Date and also the cover should be clearly marked with "UNPRICED BID".
5. The **Price Bid** shall be put in a separate sealed cover superscribed with Tender number, Tender Date & Tender Due Date & the cover should be clearly marked with "PRICE BID".
6. Both the individually enveloped **UNPRICED BID** and **PRICE BID** covers as mentioned above, have to be put in another single bigger cover clearly indicating Tender number, Tender Date & Tender Due Date at the top of the cover. This cover is to be addressed to

Purchase Executive,  
Purchase Department,  
Seamless Steel Tube Plant (SSTP),  
BHEL, Tiruchirapalli-620014, India.  
Phone No: 91 431 2578502, 2578491

7. Un-priced Bid shall only be opened on the Tender Due Date mentioned in the Tender, in the presence of Tenderers / their Authorized Representative, who may like to be present for such opening. The price bid will NOT be opened on the date of tender opening.
8. After opening the Un-priced Bid, they shall be evaluated by BHEL for their suitability. BHEL shall hold discussions with the responded Tenderers on the Technical and Commercial terms and freeze the terms & conditions of the offer. These frozen technical specifications will be communicated to responded tenderers.
9. BHEL shall offer opportunity to the responded and technically / commercially suitable Tenderers, to submit their latest Price Bid/ Impact of prices, if any in line with the frozen technical , Commercial , delivery conditions.
10. This latest Price Bid & the Impact of prices for the frozen technical specifications submitted by the Tenderers will be opened in the presence of Tenderers. Based on the above, the ranking of the Tenderers shall be made and accordingly the Tender shall be finalized.
11. "BHEL reserves the right to go for Reverse Auction (RA) instead of opening the sealed envelope price bid, submitted by the bidder. **This will be decided after techno-commercial evaluation.** All bidders to give their acceptance for participation in RA. Non-acceptance to participate in RA may result in non-consideration of their bids, in case BHEL decides to go for RA, and if BHEL decides to go for opening the sealed envelop price bid, the offer submitted during the tender due date will considered.

In case BHEL decides to go for Reverse Auction, only those bidders who have given their acceptance to participate in RA will be allowed to participate in the Reverse Auction. Those bidders who have given their acceptance to participate in Reverse Auction will have to necessarily submit "online sealed bid" in the Reverse Auction. Non-submission of "online sealed bid" by the bidder will be considered as tampering of the tender process and will invite action by BHEL as per extant guidelines in vogue.

## Terms & Conditions of REVERSE AUCTION

Against this enquiry for the subject item/ system with detailed scope of supply as per enquiry specifications, BHEL may resort to "REVERSE AUCTION PROCEDURE" i.e., ON LINE BIDDING (THROUGH A SERVICE PROVIDER). The philosophy followed for reverse auction shall be English Reverse (No ties).

1. For the proposed reverse auction, technically and commercially acceptable bidders only shall be eligible to participate.

Those bidders who have given their acceptance for Reverse Auction (quoted against this tender enquiry) will have to necessarily submit "online sealed bid" in the Reverse Auction. Non-submission of "online sealed bid" by the bidder for any of the eligible items for which techno-commercially qualified, will be considered as tampering of the tender process and will invite action by BHEL as per extant guidelines in vogue.

2. BHEL will engage the services of a service provider who will provide all necessary training and assistance before commencement of on line bidding on internet.
3. In case of reverse auction, BHEL will inform the bidders the details of Service Provider to enable them to contact & get trained.
4. Business rules like event date, time, bid decrement, extension etc. also will be communicated through service provider for compliance.
5. Bidders have to fax the Compliance form (annexure IV) before start of Reverse auction. Without this, the bidder will not be eligible to participate in the event.

In line with the NIT terms, BHEL will provide the calculation sheet (e.g., EXCEL sheet) which will help to arrive at "Total Cost to BHEL" like Packing & forwarding charges, Taxes and Duties, Freight charges, Insurance, Service Tax for Services and loading factors (for non-compliance to BHEL standard Commercial terms & conditions) for each of the bidder to enable them to fill-in the price and keep it ready for keying in during the Auction.

6. Reverse auction will be conducted on scheduled date & time.
7. At the end of Reverse Auction event, the lowest bidder value will be known on auction portal.
8. The lowest bidder has to fax/e-mail the duly signed and filled-in prescribed format for price breakup including that of line items, if required, (Annexure VII) as provided on case-to-case basis to Service provider within two working days of Auction without fail.
9. **In case BHEL decides not to go for Reverse Auction procedure for this tender enquiry, the Price bids and price impacts, if any, already submitted and available with BHEL shall be opened as per BHEL's standard practice.**
10. Bidders shall be required to read the "Terms and Conditions" section of the auctions site of Service provider, using the Login IDs and passwords given to them by the service provider before reverse auction event. Bidders should acquaint themselves of the „Business Rules of Reverse Auction“, which will be communicated before the Reverse Auction.
11. If the Bidder or any of his representatives are found to be involved in Price manipulation/ cartel formation of any kind, directly or indirectly by communicating with other bidders, action *as per extant BHEL guidelines*, shall be initiated by BHEL and the results of the RA scrapped/ aborted.
12. The Bidder shall not divulge either his Bids or any other exclusive details of BHEL to any other party.
13. In case BHEL decides to go for reverse auction, the H1 bidder(s) (whose quote is highest in online sealed bid) may not be allowed to participate in further RA process.

**Important Note to MSE Vendors**

1. 20% of the tendered quantity is earmarked for MSE suppliers in this tender.
2. Out of the 20% tendered quantity reserved for MSE suppliers, 4% shall be earmarked for procurement from MSE owned by SC / ST entrepreneurs.
3. In case MSE vendor participating in the tender quotes within the price band of L1 + 15%, they will be allowed to supply the portion of the requirement subject to acceptance of L1 price by MSE vendor. In case of more than one such MSE, the supply shall be shared proportionately.
4. MSE suppliers can avail the intended benefits only if they submit along with offer, attested copies of either EM II certificate having deemed validity (five years from the date of issue of acknowledgement in EM II) or valid NSIC certificate or EM II certificate along with CA certificate (Format enclosed) applicable for the year, certifying quantum of investment in plant and machinery within the permissible limit as per the act for relevant status (Micro or small) where the deemed validity of EM II is over. Date to be reckoned for determining the deemed validity will be the last date of technical bid submission. Non submission of such documents will lead to consideration of their bids at par with other bidders and MSE status of such suppliers shall be shifted to Non MSE supplier till the supplier submits these documents.

**Certificate by Chartered Accountant**

(hereinafter referred to as 'company') having its registered office at

..... is registered under MSMED Act 2006, (Entrepreneur

This is to Certify that M/S .....,

MeMemorandum No (Part—II).....dtd:.....,

Category: ..... (Micro/Small)). (Copy enclosed).

**Further verified from the Books of Accounts that the investment of the company as on date ..... as per MSMED Act 2006 is as follows:**

1. **For Manufacturing Enterprises: Investment in plant and machinery** (i.e. original cost excluding land and building and the items specified by the Ministry of Small Scale Industries vide its notification No.5.0.1722(E) dated October 5, 2006:

**Rs. .... Lacs**

2. **For Service Enterprises: Investment in equipment** (original cost excluding land and building and furniture, fittings and other items not directly related to the service rendered or as may be notified under the MSMED Act, 2006:

**Rs. .... Lacs**

**The above investment of Rs ..... Lacs is within permissible limit of**

**Rs ..... Lacs for ..... Micro / Small (Strike off which is not applicable)**

**Category under MSMED Act 2006.**

**Date:**

**(Signature)**

**Name -**

**Membership number -**

**Seal of Chartered Accountant**

**Annexure – B.**  
**Technical Conditions**

Vendor Code :  
Vendor Name : M/s.  
Tender No. :  
Tender Date :  
Tender Due Date :

---

| Sl.No.  | Technical Requirement  | Accepted | Not accepted |
|---|--|----------|--------------|
| 1.  | Supply Materials as per Tender Documents, without any deviation.   |          |              |
| 2.  | Delivery of materials as per Tender Documents..  |          |              |
| 3.  | Furnish Certificate for <u>Raw Material Chemistry</u> , either from manufacturer or from Reputed Test House. |          |              |
| 4.  | Furnish Certificate for Hardness   |          |              |
| 5.  | Furnish Temperature-Time Graph for Heat Treatment cycle.   |          |              |
| 6.  | Furnish Certificate for LP Test.   |          |              |
| 7.  | Supply materials with marking (PO No., Name of Vendor)   |          |              |
| 8.  | Supply materials with suitable preservation and packing  |          |              |
| <u>Deviations, if any ( attach additional sheet, if reqd) :</u><br><br> |  |          |              |

Signature :

Date :

Seal :

**Annexure – C.**  
**Commercial Conditions**

|              |              |                  |
|--------------|--------------|------------------|
| Vendor Code: | Vendor Name: |                  |
| Tender No.:  | Tender Date: | Tender Due Date: |

| Sl.No   | Commercial Terms   | Accepted |
|---|--|----------|
| C1.   | <u>Delivery Terms :</u><br>Free delivery at BHEL/SSTP Stores duly including Packing, Forwarding, Freight and Insurance charges   |          |
| C2.   | <u>Payment :</u><br>100% after 45 days after receipt and acceptance of materials by BHEL   |          |
| C3.   | <u>LIQUIDATED DAMAGES:</u> It is clearly understood among the parties to the Contract that TIME IS THE ESSENCE OF THE CONTRACT. Therefore, the delivery of the goods specified in the Purchase Order shall be made within the time prescribed. Where the Seller supplies or despatches the goods, beyond the delivery period specified, and the Purchaser will have no obligation to accept the goods. If accepted, Liquidated Damages at the rate of 0.5% (Zero point five Percent) of the value of goods delayed, per week of delay, subject to a maximum of 10% (Ten Percent) or part thereof, will be levied without prejudice to any other relief or compensation due to the Purchaser under any other conditions of the Contract.<br><u>RISK PURCHASE:</u> Alternatively, the Purchaser, at his option, will be entitled to terminate the Contract and to purchase elsewhere at the risk and cost of Seller, either the whole of the goods or any part, which the Seller has failed to deliver or dispatch within the time stipulated as aforesaid or if the same were not available the best and nearest available substitute thereof. The Seller shall be liable for any loss, which the Purchaser may sustain by reason of such Risk Purchase(s), in addition to penalty at the rate mentioned in Clause No.06 above. |          |
| C4.   | <u>Delivery Period :</u> As per Enquiry schedule.  |          |
| C5.   | <u>Validity – minimum 60 Days from the date of Tender Opening.</u>   |          |
| <u>Deviations if any (attach additional sheet, if required) :</u> |  |          |

| Sl.No. | Commercial Terms  |   |
|--------|---|---|
| C6.    | Validity of Offer (Date)  |   |
| C7     | Excise Duty (including Cess) %<br>(with Break up details)   |   |
| C8.    | TVNAT / CST (%)   |   |
| C9.    | Delivery Period (Days/Weeks/Months)<br>Please refer the Enquiry.  |   |
| C10.   | Other Cost (if any) - % (or) Rs.  |   |
| C11.   | Are you Micro/Small/Medium Industry?<br>(If YES, please furnish MSM Regn.No., along with a copy of MSM Certificate) | YES / NO<br>MSM No.<br>MSM Certificate enclosed(Yes/NO) |

Signature with Date :