 432-022	ENQUIRY VALVES	Bharat Heavy Electricals Limited (A Government of India undertaking) High pressure boiler plant Purchase department/valves Tiruchirappalli-620 014.	Phone: +91 9442502544 & 0431-2577544 FAX : 0431-2520383 Email: bppreddy@bheltry.co.in	
		Enquiry No. EN-VAL-OT-1008	Date 12.01.2015	Due Date For Quotation 02.02.2015
Please quote Enquiry No., and due date in correspondences This is only a request for quotation and not an order.				
<u>Date , Time & Venue of tender opening :</u> 02.02.2015 at 14.30 Hrs. at Valves Purchase Conference Hall , Building No 24, III Floor BHEL, Tiruchirappalli-620 014, Tamil Nadu State, India.	<u>Scope of work</u> Repair work of Valve castings inside BHEL premises <u>Enclosures</u> - Enquiry Instructions, Annexure - A - Bill of Quantity, Annexure – B - Priced Bid format, Annexure - C - Terms and Conditions, Annexure - D - Standard Inspection Procedure (SIP:VS:17/ Rev.03) - Standard Inspection Procedure (SIP:VS:11/ Rev.02)			
The applicable Taxes prevalent on the date of quotation should be clearly indicated in the Pre-qualification & Techno-commercial quotation (Part –A) itself. Please, submit your lowest quotation in duplicate subject to our terms and conditions , for the above Bill of Quantity, so as to reach us on or before the due date by 14.00 Hrs. (IST) Quotation will be opened at 14.30 Hrs. (IST) on the due date in the presence of tenderers who may like to be present. Late tenders are liable to be rejected.			Yours faithfully, For Bharat Heavy Electricals Ltd B Rajendra Prasad Reddy Engr/Purchase/Valves	

ENQUIRY INSTRUCTIONS

1. Sealed tenders in two parts; Part-I: Pre-qualification Techno-commercial bid and Part-II: Priced bid are invited for entering into Rate Contract for valve casting repair work inside BHEL premises.

The two bids should be submitted in separate inner envelopes duly mentioning the details as follows:

Part	Bid	Superscription on envelope
I	Pre-qualification & Techno-Commercial Quotation in response to tender enquiry No. EN-VAL-OT-1008 Dt: 12.01.2015	PART-I "Pre-qualification & Techno-Commercial Bid" Tender Enquiry No. EN-VAL-OT-1008 Dt: 12.01.2015 Due date of opening: 02.02.2015 Sender:
II	Priced Quotation in response to tender enquiry No. EN-VAL-OT-1008 Dt: 12.01.2015	PART-II "Priced Bid" Tender Enquiry No: EN-VAL-OT-1008 Dt: 12.01.2015 Sender:

Both the sealed envelopes should be put in an outer envelope clearly mentioning Tender Enquiry No. and due date of opening & sender's address on it. Quotations shall reach us by 14.00 Hrs on 02.02.2015

Necessary Document to be submitted in Part-I:

- Authorization/ Approval Letter issued by Director of Boilers for permitting the contractor to carry out the repair of steel castings.
- IBR Qualification for minimum 2 welders for Carbon Steel (WCB&WCC) & Alloy Steel (WC6&WC9).
- Past experience in repair of castings is to be supported with necessary documentation - Customer details and validity of IBR approval during that period.
- List of available equipment, tools and tackles necessary for carrying out repair work.
- Un-priced bid with all taxes and duties (extra/inclusive) - % mentioned and other applicable commercial conditions.
- Acceptance of all terms and conditions. Terms and conditions (Annexure-C) to be signed in all pages and sent back. **If nothing is mentioned for any terms and condition, it shall be concluded that the same is accepted.**
- Filled in Annexure-A to be submitted mentioning "Quoted" or "regretted" against each line item.
- Documents of the following statutory Codes
 - ESI Code.
 - P. F.Code No.

- Labour licence (Central / State Government) should be submitted before commencement of work.
- PAN No. (In case not available, proof of having applied with Acknowledgement from concerned authorities)

Document to be submitted in Part-II:

Rate per Cubic Centimeter (CC) of repair to be mentioned in figures as well as in words in the Bill of Quantity (Annexure - A). **No other condition shall be mentioned.**

All amounts shall be indicated both in words as well as figures. Where there is difference between amount quoted in words and figures, amount quoted in words shall prevail.

Bill Of Quantities

Sl no	Particular	Estimated Volume for 2 years CC	Quoted/ Not Quoted
1	CARBON STEEL		
1A	Material removal for Carbon steel (Gouging, Grinding)		
1B	Material build-up for Carbon steel (Welding & Grinding)		
Total	Welding repair of Carbon Steel Material (1A+ 1B)	9,50,000	
2	ALLOY STEEL		
2A	Material removal for Alloy Steel (Gouging , Grinding)		
2B	Material build-up for Alloy steel (Welding&Grinding)		
Total	Welding repair of Alloy Steel Material (2A+ 2B)	6,20,000	
3	C12A		
3A	Material removal for C12A material (Grinding only) (Removal of excess material using electric grinder only)	1,05,000	
	Total package (1+2+3)		

Priced Bid Format

Sl no	Particular	Estimated Volume for 2 years CC	Quoted Price in figures Rs/CC	Quoted Price in words Rs/CC
1	CARBON STEEL			
1A	Material removal for Carbon steel (Gouging, Grinding)			
1B	Material build-up for Carbon steel (Welding & Grinding)			
Total	Welding repair of Carbon Steel Material (1A+ 1B)	9,50,000		
2	ALLOY STEEL			
2A	Material removal for Alloy Steel (Gouging , Grinding)			
2B	Material build-up for Alloy steel (Welding&Grinding)			
Total	Welding repair of Alloy Steel Material (2A+ 2B)	6,20,000		
3	C12A			
3A	Material removal for C12A material (Grinding only) (Removal of excess material using electric grinder only)	1,05,000		
	Total package (1+2+3)			

TERMS & CONDITIONS

1. Repair of Valve castings inside BHEL premises in 3 identified locations.
2. Bidder to quote rate on “Rate/CC” of repair work separately for Carbon Steel and Alloy Steel, metal removal by gouging & grinding or grinding for Carbon steel & Alloy steel, grinding of C12A material, material build-up by welding and grinding for Carbon steel and Alloy steel as per BOQ in Annexure-A.
3. The price will be firm for a period of 2 years from the final approval of the competent authority.
4. The work should be carried out within our premises allotted to the contractor.
5. BHEL will provide the required space, power and compressed air.
6. BHEL will provide the movement facility for the castings weighing more than 1 MT.
7. The contractor has to arrange a temporary closed shed in the identified location in BHEL for carrying out the welding activities and proper storage, presentation of welding equipment and consumables. The approval for temporary shed should be got from BHEL.
8. The jobs up to 1 MT for repair are to be collected from Stores/Shops to the identified repair shops in BHEL and after completion of repair duly certified by BHEL QC to return back to concerned Stores/Shops.
9. The contractors are to arrange necessary material handling facilities.
10. BHEL will negotiate/ Re-float the tender in case the quoted prices are not acceptable.
11. BHEL will enter into Rate Contract with 3 contractors. For this BHEL will counter-offer the negotiated L1 rates to L2 and L3 contractors. Distribution/Allocation of load: L1 – 45%; L2 – 30%; L3 – 25%. In case of 2 vendors the ordering will be done in the ratio of L1 – 60% & L2 – 40%.
12. ***Subject to having minimum of 3 eligible contractors, the H1 contractor will not be considered.*** Qualification:
 - a. Experience in steel casting repair under IBR inspection for a period of 2 years minimum.
 - b. The contractor should have a valid IBR approval for carrying repair of steel casting for past 2 years.
 - c. The contractor shall submit the necessary Authorisation / Approval Letter issued by Director of Boilers for permitting the contractor to carry out the repair of castings.
 - d. Past experience in repair of castings is to be supported with necessary documentation - Customer details and validity of IBR approval during that period.
 - e. Minimum 2 IBR Qualified welders for Carbon Steel (WCB/WCC) & Alloy Steel (WC6&WC9) along with supporting manpower to carry out the job.
 - f. Welder qualification with IBR and IBR approval for carrying out repair of steel castings should be kept valid through the contract period.
 - g. The contractor should arrange at his own expense, the welding power source for Welding and gouging, approved welding consumables, tools, tackles, consumables and tools for carrying out LPI.
 - h. Equipment for grinding and other operations should be arranged by contractor.

13. Selection criteria:

- ⇒ Meet all qualification criteria (12a - 12h)
- ⇒ Competitive rate
- ⇒ If more than 3 contractors become L1 – Shortlisting will be based on Number of years of service in casting repair – IBR certificate
- ⇒ In case of two or more having same experience, the turnover in the last 2 years would be taken as the deciding criteria. The contractor with higher turnover would be considered for qualification.
- ⇒ The L1 contractor will be arrived at, on comparison of cumulative prices quoted for total package. i.e., Carbon steel + Alloy steel+C12A. The purpose of getting separate prices in 1A, 1B, 2A, 2B & 3A is to allocate the work based on the nature of defect and rework required.”

14. PDO meeting convened by Stores will review the nature of defect and decides the scope of repair of the castings received through SPDO from Sub-contracting contractor and material received in PDO identified by Valves Production/OP&C/Buildings V & VI. Purchase/Valves will identify the repair shop and places service order on casting repair contractors.

15. The work shall be completed considering the urgency of the shop requirement. The maximum period for completing the repair work is One week. In case of non-performance, the work shall be cancelled and re-allotted to other repair contractor. The contractor shall arrange his own BHEL approved electrodes, consumables and pre/post-heating facilities. The contractor to ensure sufficient man power for welder, fitter and grinder to complete the job in the stipulated time.

16. The repair should be carried out in a sound manner strictly as per our procedure for steel castings SIP: VS: 17(latest revision), and for OFE castings SIP: VS: 11(latest revision). If any defects are found in the repaired part, the same should be rectified without any extra charges. The repaired castings have to be cleared by our RM QC/OP&C.

17. The contractor shall do the co-ordination with IBR, NDTL, Inspection and Stores for arranging repair work. After completion of repair work, the contractor shall prepare all related documents.

18. The volume of repair will be certified by our RM QC/OP&C/ Bldg V & VI.

19. After the inspection clearance, the castings have to be handed over to our Valves Production/OP&C/Bldg V & VI/Stores (Ward 20, 24, 33 & 35).

20. The invoice may be submitted along with the volume reports certified by our QC / Valves Production / OP&C and delivery challan duly acknowledged by our Valves Production / Stores / OP&C.

21. Payment will be made against the above invoice.

22. The rework report should contain the following details.

Notification No.

- i. DB No.
- ii. Date
- iii. Melt No. / RT No.
- iv. Supplier Name
- v. Description
- vi. Qty.
- vii. Volume
- viii. The nature of repair work carried out

- 23) The Notification number shall be punched on the casting after repair work is completed and accepted by RMQC and NDTL.
- 24) Contractors should keep the records of repair / IBR Certifications etc., for 3 years after repair.
- 25) 100% payment after 45 days after submission of bills to Finance.
- 26) The Contractor shall follow the safety / environmental norms followed at BHEL and accommodate for all safety issues concerning to their employees. The contractor to provide safety equipment like safety shoes, Aprons, gloves, goggles etc.,
- 27) Separate PF and Employees State Insurance code must be available for the people working under the contractor.
- 28) Special Provisions for Micro and Small Enterprises (MSE) bidders registered as per MSME act: 20% of the tendered quantity is earmarked for MSE suppliers in this tender. Out of the 20% tendered quantity reserved for MSE suppliers, 4% shall be earmarked for procurement from MSE owned by SC/ST entrepreneurs.

In case MSE vendor participating in the tender quotes within the price band of L1 + 15%, they will be allowed to supply the portion of the requirement subject to acceptance of L1 price by MSE vendor. In case of more than one such MSE, the supply shall be shared proportionately.

MSE suppliers can avail the intended benefits only if they submit along with offer, attested copies of either EM II certificate having deemed validity (Two years from the date of issue of acknowledgement in EM II) or valid NSIC certificate or EM II certificate along with CA certificate (Format enclosed as per Annexure I) applicable for the year, certifying quantum of investment in plant and machinery within the permissible limit as per the act for relevant status (Micro or small) where the deemed validity of EM II is over. Date to be reckoned for determining the deemed validity will be the last date of technical bid submission. Non submission of such documents will lead to consideration of their bids at par with other bidders and MSE status of such suppliers shall be shifted to Non MSE supplier till the supplier submits these documents.

Certificate by Chartered accountant on Chartered Accountant’s letter head

This is to Certify that M/s
(hereinafter referred to as ‘company’) having its registered office at
..... is registered under MSMED Act 2006, (Entrepreneur Memorandum
No (Part-II dated:..... Category:
.....(Micro/Small) (Copy enclosed).

Further verified from the Books of Accounts that the investment of the company as on date
As per MSMED Act 2006 is as follows:

Rs. Lacs

For Manufacturing Enterprises: Investment in plant and machinery (i.e. original cost excluding land and building and the items specified by the Ministry of Small Scale Industries vide its notification No.S.O 1722 (E) dated October 5, 2006.

Rs.....Lacs

2. For Service Enterprises: Investment in equipment (original cost excluding land and building and furniture, fittings and other items not directly related to the service rendered or as may be notified under the MSMED Act, 2006:

Rs.Lacs

The above investment of Rs.....Lacs is within permissible limit of
Rs.....Lacs forMicro/Small (Strike off which is not
applicable) Category under MSMED Act 2006.

Date:

(Signature)

Name:

Membership number:

Seal of Chartered Accountant:





BHARAT HEAVY ELECTRICALS LIMITED
TIRUCHIRAPPALLI 620 014

QUALITY ASSURANCE

SIP: VS: 11 / Rev.02

Page 1 of 4

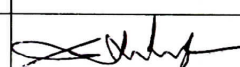
INSPECTION OF MINOR DEFECTS (IN OFE CASTINGS)

REV.	DATE	PREPARED	REVIEWED	APPROVED
02	27.12.2014	 N.Nagamuthu Pandian	 S.Selvarajan	 U.Revisankaran

Record of Revisions

Rev.00	01.08.1996	Fresh
Rev.01	14.11.2000	Text re-written, Details added for addl. components
<i>Rev:02</i>	<i>27.12.2014</i>	<i>Modified in Totality</i>

1.0 SCOPE

Acceptance criteria and repair procedure for Foundry defects in castings observed after machining of PSL 1,2,3 & 3G OFE components manufactured to API Spec 6A

2.0 DEFECT IDENTIFICATION

- 2.1 No defects are allowed on critical and sealing surfaces as shown in the enclosed sketches. *If defects are noticed in the critical and sealing areas, such areas to be examined by Magnetic Particles Inspection(MPI) as per ASTM E709 and/ or Liquid Penetrant Inspection(LPI) as per ASTM E165 for Ferromagnetic material as applicable. LPI shall be done on Non- Ferromagnetic materials. Repair on relevant indication shall be carried out as per Cl.4.0.*
- 2.2 If defects are noticed in other than critical and sealing areas, such areas to be examined by *Visual Inspection as per MSS SP-55 and Liquid Penetrant Inspection as per ASTM E165. Repair on relevant indication shall be carried out as per Cl.4.0.*
- 2.3 If any indications are believed to be non-relevant on the basis that they are not associated with a surface rupture, they shall be examined by liquid penetrant surface NDE methods, or removed and re-inspected, to confirm their non-relevancy.
- 2.4 Relevant Indication(*as per ASME B16.34,2013 edition*):
 Surface NDE indications with major dimension greater than 1.6mm
 Linear Indication : Relevant indications where length $\geq 3 \times$ Width
 Rounded Indication : A surface NDE indication circular or elliptical with its length $< 3 \times$ Width

3.0 ACCEPTANCE CRITERIA

- 3.1 *Critical and pressure contact sealing surfaces: No relevant indications is permitted.*
- 3.2 *Other than Critical and pressure contact sealing surfaces: As per Table-1*

TABLE-1

Acceptance Norms	Ferromagnetic material	Non Ferromagnetic material
<i>Four or more relevant indications in a line separated by less than 1,6 mm (1/16 in) (edge to edge) are unacceptable</i>	√	√
<i>No relevant linear indication</i>	--	√
<i>No relevant rounded indication with a major dimension equal to or greater than 5 mm (3/16 in).</i>	√	√
<i>No more than ten relevant indications in any continuous 40 cm² (6 in²) area.</i>	√	--

4.0 REPAIR OF RELEVANT INDICATIONS:

- 4.1 *Indications to be removed by grinding and the defect removal confirmed by MPI / LPI Prods are not permitted on well-Fluid surfaces or sealing surfaces while doing MPI.*
- 4.2 *Repair welding by qualified procedures and qualified welders as per ASME Sec IX. All repair welds shall be examined using the same methods and acceptance criteria as used for examining the base metal ie.,original casting.*

- 4.3 Post Weld Heat Treatment (PWHT) shall be carried out as specified in the Welding Procedure Specification(WPS).
- 4.4 All surface NDE methods(LPI/MPI) shall be performed after final heat treatment and final machining operations in case of all accessible wetted surfaces and sealing surfaces of each finished part.
- 4.5 The examination shall include 13mm of adjacent base metal on all sides of weld.
- 4.6 The following NDE shall be done in general on all repair welds as a minimum.
- i) Visual Inspection
 - ii) LPI and or MPI.
- 4.7 Wet MPI shall be carried out for PSL 3 & 3G.
- 4.8 All repair welds where the repair is greater than 25 % of the original wall thickness or 25 mm (1 in), whichever is less, shall be examined by either Radiography or Ultrasonic methods after all welding and post-weld heat treatment.

5.0. DOCUMENTATION

The Reports of minor repair on casting shall be documented and maintained.

* Critical Sealing areas

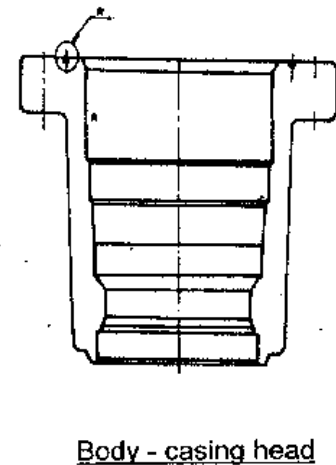
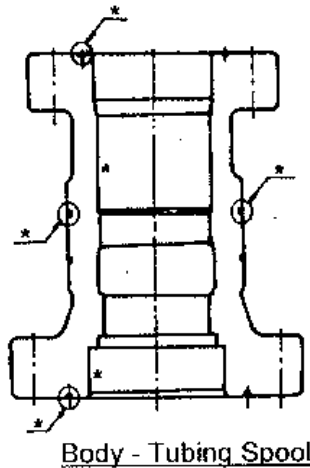
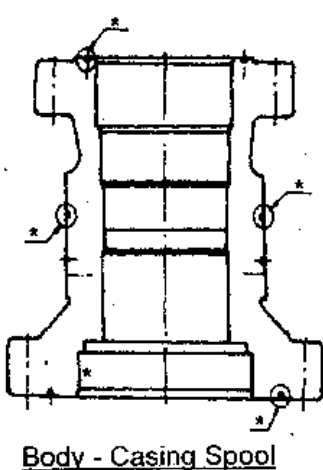
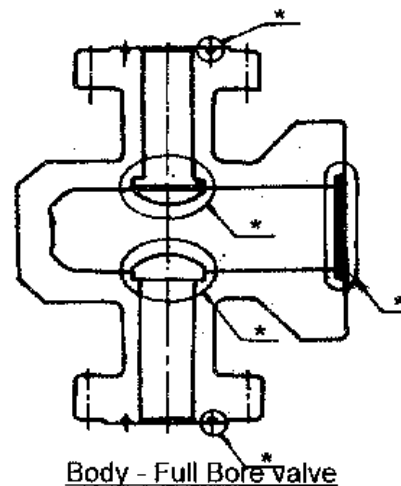
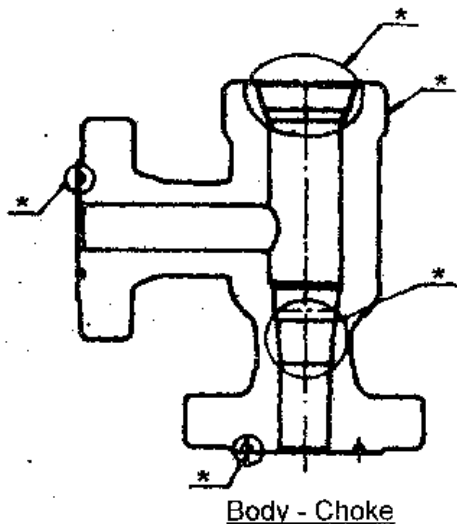





BHARAT HEAVY ELECTRICALS LIMITED
TIRUCHIRAPPALLI 620 014

QUALITY ASSURANCE

SIP:VS:17 / Rev.03

Page 1 of 6

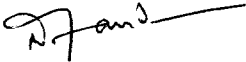
PROCEDURE FOR REPAIR OF STEEL CASTINGS - VALVES

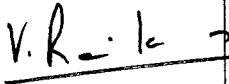
REV.	DATE	PREPARED	REVIEWED	APPROVED
00	01.08.1996	R.Kaliaperumal	R.Arthanareeswaran	C.R.Raju
01	22.06.2006	S.Selvarajan	R.Arthanareeswaran	C.R.Raju
02	15.07.2011	D.Sudhakaran	S.Selvarajan	V.Ravikumar
03	06.06.2013	 N.Nagamuthu Pandian	 S.Selvarajan	 V.Ravikumar

RECORD OF REVISIONS

Rev No	Date	Clause No.	Details of revision
00	01.08.1996	--	This replaces PR:QE:195/00
01	22.06.2006	1.1	Specification A217 C12A added.
		2.2.1	Revised.
		4.2	C12A requirement added
		5.14	ROH & ROC requirements added
		Table-1	Modified and details of Specification A217 C12A added
		Table-2	Added
02	15.07.2011	5.4	Revised
		5.14	Changed to Cl.5.16 and sub clause 5.16.1 to 5.16.4 added. Details on C12A added.
		5.14.2	Changed to Cl.5.15
		Table-1	Note-1 change to Cl.5.16.2
03	06.06.2013	5.16.1	Revised. Ni+Mn content restricted for C12A welding consumable.

1.0 SCOPE

- 1.1. This procedure details out the requirements for repair of Steel castings used in Valves covering the following specifications.

Carbon steel: ASTM A 216 WCB & WCC

Alloy steel: ASTM A217 C5, C12A, WC6, WC9 & CSN 422744.6

Martensetic Stainless steel: ASTM A 217 CA15,

Austenitic Stainless steel: A 351 CF3M, CF8, CF8M & CF8C

2.0 DEFECTS THAT DO NOT REQUIRE WELD REPAIR

2.1 Machinable surfaces

- 2.1.1 Foundry defects other than cracks, shrinkages and cold shuts can be left without weld repair on machinable areas provided that the depth of such defects is less than 75% of the machining allowance provided.

- 2.1.2 After machining, if any sand inclusions or blow holes are found, which are less than 3 mm in size and separated from the adjacent defect by at least 25 mm, they can be left without repair. This should be judiciously decided when defects are noticed on sealing surfaces.

2.2 Non-machinable surfaces

- 2.2.1 Foundry defects other than cracks, shrinkages and cold shuts can be dressed smoothly by grinding provided that the depth of such defects is less than 5% of the specified wall thickness with size less than 10 mm, separated from one another by at least 100 mm and maintaining minimum wall thickness at those locations.

3.0 DEFECTS THAT REQUIRE WELD REPAIR

- 3.1 All the defects, which are not acceptable as per the respective standards of Visual inspection and NDE excluding those listed in clause 2.0, and defects detected during machining or hydraulic test can be salvaged by sound welding practices, provided that the defects are not extensive and are accessible for repair.

4.0 SURFACE PREPARATION

- 4.1 The defective areas shall be identified and marked for repair.

- 4.2 Defects shall be removed by grinding, machining or air arc gouging to obtain a sound base for welding. If air arc gouging is employed, it shall be done with preheating as given in Table 1. The gouged area shall be ground to remove all black spots. Gouging is not permitted for C12A materials. The ground/machined area shall be tested by LPI/MPI to ensure defect removal.

- 4.3 The defective area must be adequately prepared to permit correct manipulation of the electrode.

- 4.4 The area to be welded shall be free from sand, oil, paint, grease etc.

5.0 WELDING PROCEDURE

- 5.1 The repair welding shall be done only by IBR approved works.

- 5.2 The procedure used for welding shall be qualified in accordance with ASTM A 488/ASME Section IX.

- 5.3 The welders employed for repair work shall be qualified in accordance with IBR.
- 5.4 The welding consumables and parameters shall be as per the qualified procedures. The recommended welding consumables are given in Table 1. Only BHEL approved brands of Electrodes are to be used. The use of other welding filler material is only allowed after prior agreement with the BHEL.
- 5.5 Before welding, the electrodes shall be baked at 150-200 deg. C for 1 hour for stainless steel and 250-300 deg. C for 1 hour for others and stored at 150 deg. C till use.
- 5.6 Preheating for welding shall be as given in Table 1.
- 5.7 The welding current should be kept as low as possible consistent with smooth operation and a good wash at the sides.
- 5.8 Wherever possible, the casting should be positioned for down hand welding operation. When extra long welds or several repair positions are involved, it is preferable to stagger the welding operation to distribute the heat and to minimise the distortion.
- 5.9 Welding shall be done using stringer bead technique, with beads not more than 50-75 mm in length.
- 5.10 After completing each layer, the weld surface shall be thoroughly cleaned to ensure complete slag removal before depositing the next layer.
- 5.11 When restriking, the arc should be started ahead of the previous weld run, moved back over the tapered portion and then continued forward.
- 5.12 After completion of welding and during interruptions, the job shall be post heated at temperatures as given in Table 1.
- 5.13 The weld profile shall merge smoothly with the contour of the casting and shall be free from slag, spatter and notches. The weld reinforcement shall be dressed up.
- 5.14 All major repaired castings shall be post weld heat treated.
For CS & AS, A major repair is defined as the repair on castings that have leaked during hydraulic test or where the depth of repair exceeds 20% of the wall thickness of the casting or 25 mm whichever is less or the extent of repair exceeds 65 Sq.cm.
- 5.15 After welding, post weld heat treatment shall be done at temperatures indicated in Table-1, with a minimum soaking time as specified in WPS (or 1 hour per inch of the weld thickness if no where specified) and cooled in furnace up to 400 deg. C. Rate of heating and cooling shall be as per Table-2
- 5.16 Weld repair in P15E Group-1 (C12A) material to be done only after approval by BHEL. All repaired C12A castings to be Post weld heat treated irrespective of depth or size of repair.
- 5.16.1 The welding filler materials shall be in accordance to the WPS. The available welding filler materials are :
- Cromocord 9 M (Oerlikon)
 - Fox C 9 MV (Bohler)
 - Cromo 9V (Thyssen)
- In addition, the sum of the Ni+Mn content, in all welding consumables used to weld repair C12A castings, shall not exceed 1.0%.
- 5.16.2 Preheat shall be maintained for till welding is completed. Interpass temperature shall be limited to 350 deg.C. After post heating, welds shall be slowly cooled to room temperature and then PWHT shall be taken up within 72 hours. Heating and cooling rates for PWHT shall be as Table-2, but shall not exceed 140 deg.C/ hour and controlled cooling shall be done up to 350 deg. C.

5.16.3 Total holding time of all heat treatment performed (tempering and stress relieving) after normalizing shall not exceed 40 hrs at $\geq 730^{\circ}\text{C}$. If many heating cycles are necessary, the temperature before last heating can be reduced to 730°C .

5.16.4 On each casting, weld hardness shall be checked random wise and documented accordingly. Values of max 350 HV10 are allowed.

6.0 NON DESTRUCTIVE EXAMINATION

6.1 For minor defect, after completion of welding, the repair weld shall be tested by LPI/MPI.

6.2 For major defect, the repaired area shall be re-examined by the NDE method which originally disclosed the defect. MT/PT shall be performed after PWHT if performed as above. Weld repairs made as a result of RT shall be RT tested after welding. The acceptance standards for porosity and slag inclusion shall be as per UW-51 of ASME Section VIII Division 1.

7.0 SURFACE TREATMENT AFTER WELDING

7.1 Austenitic stainless steel castings (A 351 CF3M, CF8, CF8C & CF8M) shall be acid pickled and passivated after welding as per the following procedure.

7.1.1 Pickling

7.1.1.1 Pickling shall be done by immersing the castings in the pickling solution, which consists of Nitric acid 15-20% by volume, Hydrofluoric acid 2-5% by volume and the rest water, for 2 hours. The pickling tank shall be of stainless steel material. After pickling, the entire surface shall be bright. If any black patches are present, they shall be scrubbed using stainless steel wire brushes and the effectiveness of pickling shall be checked.

7.1.1.2 After pickling, the castings shall be rinsed in running service water having chloride content not exceeding 25 PPM. The rinsing shall be continued until there is no sign of free acid left when tested with Methyl orange indicator.

7.1.2 Passivation

7.1.2.1 Passivation shall be done by immersing the castings in the passivation bath, which consists of Nitric acid 15-20% by volume and the rest demineralised water, for 3 hours. The passivation tank shall be of stainless material.

7.1.2.2 After passivation, the castings shall be rinsed in running service water having chloride content not exceeding 25 PPM. The rinsing shall be continued until there is no sign of free acid left when tested with Methyl orange indicator.

7.1.2.3 The satisfactory passivity of the surface shall be checked using stainless steel passivity test kit.

7.1.2.4 After satisfactory completion of this test, the castings shall be again rinsed in demineralised water having chloride content not exceeding 0.5 PPM and specific conductivity not exceeding 10 micro mhos. The rinsings shall be checked for chloride with 1% Silver nitride, which shall not exceed 0.5 PPM.

8.0 DOCUMENTATION

8.1 The details of repair work carried out shall be documented and correlated to welder and NDE reports.

Table - 1**Welding procedure for repair of steel castings**

Casting Material	Electrode Specification	Minimum Preheat in ° C	Minimum Post heat Temperature in ° C	PWHT Temperature in ° C
A 216 WCB, A 216 WCC	E 7018 - A1	150	150 for 2 hours	595 to 625
A 217 WC6	E 8018 B2	220	220 for 2 hours	650 to 680
A 217 WC9, A 217 C5, CSN 422744	E 9018 B3	220	220 for 2 hours	675 to 705
A 217 C12A	E 9015 B9 E 9018 B9	220-280	220-280 for 2 hrs	750 to 770
A 217 CA15	E 410	220	220 for 2 hours	760 to 790
A 351 CF3M, A 351 CF8M	E 316	Nil	Nil	Nil
A 351 CF8, A 351 CF8C	E 347	Nil	Nil	Nil

Table - 2

Rate of heating / cooling shall be as below unless otherwise specified. Cooling shall be in furnace up to 400 deg. C and further in Air.

Thickness of Material	Maximum Rate of Heating & Cooling above 400 deg. C (For A217 C12A it shall be 350 deg.C)
Up to 25mm	220°C/Hr (140°C/Hr max for A217 C12A)
Over 25 - 50mm	110°C/Hr
Over 50 - 75mm	75°C/Hr
Over 75mm	55°C/Hr
