

TENDER SPECIFICATION

NO: BHE/PW/PUR/HZRI-ENB/1323

FENCING OF OPEN STORAGE YARD (10,000 SQM) WITH GATE, CLOSED STORAGE SHED FOUNDATION UPTO FFL (15X60M) ETC. INCLUDING ITS INTERNAL/EXTERNAL ELECTRIFICATION, ASSOCIATED CIVIL WORK OF PORTA CABIN COMPLEX.

AT

4x93.1 MW RUPPL HMD Hazira Project

VOLUME- I- TECHNICAL BID

TENDER SPECIFICATIONS CONSISTS OF:

- Notice Inviting Tender,
- Technical Conditions of Contract,
- Special conditions of Contract,
- General conditions of Contract
- Forms & Procedures

VOLUME I



Bharat Heavy Electricals Limited
(A Government of India Undertaking)
Power Sector - Western Region
345-Kingsway, Nagpur-440001

Volume No	Description	Hosted in website bhel.com as files titled
NIL	Tender Specification Issue Details	(Part of Vol-IA---)
NIL	Notice Inviting Tender	(Part of Vol-IA---)
I-A	Technical Conditions of Contract	Vol-IA----
I-B	Special Conditions of Contract	Vol-IBCD---
I-C	General Conditions of Contract	(Part of Vol-IBCD-)
I-D	Forms & Procedures	(Part of Vol-IBCD-)
II	Price Bid Specification	Vol-II-

LEGEND:

This document (i.e. NIT & Vol-I A) is hosted in BHEL web page (www.bhel.com) as a (Vol- I) of Technical Bid

\$: “Vol I -B, I-C, I-D” of Part-I (Vol- I) Hosted in BHEL web page (www.bhel.com) separately as a part of Technical Bid.

@: Vol-II- Price bid is issued as a separate hard copy booklet ‘Tender Specifications – Volume-II (Price Bid-)’. Hosted in BHEL web page (www.bhel.com) separately as titled **“PRICE BID-”**

Tender Specification Issue Details

NO: BHE/PW/PUR/HZRI-ENB/1323

FENCING OF OPEN STORAGE YARD (10,000 SQM) WITH GATE, CLOSED STORAGE SHED FOUNDATION UPTO FFL (15X60M) ETC. INCLUDING ITS INTERNAL/EXTERNAL ELECTRIFICATION, ASSOCIATED CIVIL WORK OF PORTA CABIN COMPLEX.

AT

4x93.1 MW RUPPL HMD Hazira Project

EARNEST MONEY DEPOSIT: Refer Notice Inviting Tender

LAST DATE FOR TENDER SUBMISSION. Refer Notice Inviting Tender

THESE TENDER SPECIFICATION DOCUMENTS CONTAINING VOLUME-I AND VOLUME- II ARE ISSUED TO:

M/s.

.....

PLEASE NOTE:
THESE TENDER SPECS DOCUMENTS ARE NOT TRANSFERABLE.

For Bharat Heavy Electricals Limited

DY. GENERAL MANAGER (Purchase)
Place: Nagpur
Date:

1323

NOTICE INVITING TENDER

Bharat Heavy Electricals Limited



NOTICE INVITING TENDER (NIT)
**NOTE: BIDDER MAY DOWNLOAD FROM WEB SITES
OR
PURCHASE TENDERS FROM THIS OFFICE ALSO**

To

Dear Sir/Madam

Sub : NOTICE INVITING TENDER

Sealed offers in two part bid system are invited from reputed & experienced bidders (meeting [PRE QUALIFICATION CRITERIA](#) as mentioned in Annexure-I) for the subject job by the undersigned on the behalf of BHARAT HEAVY ELECTRICALS LIMITED as per the tender document. Following points relevant to the tender may please be noted and complied with.

1.0 Salient Features of NIT

SL NO	ISSUE	DESCRIPTION
i	TENDER NUMBER	BHE/PW/PUR/HZRI-ENB/1323
ii	Broad Scope of job	FENCING OF OPEN STORAGE YARD (10,000 SQM) WITH GATE, CLOSED STORAGE SHED FOUNDATION UPTO FFL (15X60M) ETC. INCLUDING ITS INTERNAL/EXTERNAL ELECTRIFICATION, ASSOCIATED CIVIL WORK OF PORTA CABIN COMPLEX AT 4x93.1 MW RUPPL HMD Hazira Project
iii	DETAILS OF TENDER DOCUMENT	
a	Volume-IA	<i>Technical Conditions of Contract (TCC) consisting of Scope of work, Technical Specification, Drawings, Procedures, Bill of Quantities, Terms of payment, etc</i> <i>Applicable</i>
b	Volume-IB	<i>Special Conditions of Contract (SCC)</i> <i>Applicable</i>
c	Volume-IC	<i>General Conditions of Contract (GCC)</i> <i>Applicable</i>
d	Volume-ID	<i>Forms and Procedures</i>
e	Volume-II	<i>Price Schedule (Absolute value).</i> <i>Applicable</i>
iv	Issue of Tender Documents	<p>1. Sale from BHEL PS Regional office at : Start :22/09/2014 , Closes: 06/10/2014 , Time : 16.00 Hrs</p> <p>2. From BHEL website (www.bhel.com)</p> <p>Tender documents will be available for downloading from website till due date of submission</p> <i>Applicable/ Not applicable</i>
v	DUE DATE & TIME OF OFFER SUBMISSION	<p>Date : 07/10/2014, Time 15.00 Hrs Place : <u>BHEL PS Regional office at :Nagpur</u></p> <p>Tenders being submitted through representative shall be submitted at dispatch section of of PSWR HQ Office after making entry/registration at the reception. For any</p> <i>Applicable</i>

**BHEL PSWR
Notice Inviting Tender**

Tender Specification No: BHE/PW/PUR/HZRI-ENB/1323

Page 6 of 49

		assistance on the matter kindly contact following officials: Pratish Gee Varghese/Sr Engineer(Purchase Shivkesh Meena / Engineer (Purchase)	
vi	OPENING OF TENDER	1 hours after the latest due date and time of Offer submission Notes: (1) In case the due date of opening of tender becomes a non-working day, then the due date & time of offer submission and opening of tenders get extended to the next working day. (2) Bidder may depute representative to witness the opening of tender	Applicable
vii	EMD AMOUNT	Rs 1,00,000/- (Rupees One Lakhs Only)	Applicable
viii	COST OF TENDER	Rs 2000/- (Rupees Two Thousand Only)	Applicable
ix	LAST DATE FOR SEEKING CLARIFICATION	Five days before the due date of offer submission. Along with soft version also, addressing to undersigned & to others as per contact address given below	Applicable
x	SCHEDULE OF Pre Bid Discussion (PBD)	Date :	Not applicable.
xi	INTEGRITY PACT & DETAILS OF INDEPENDENT EXTERNAL MONITOR (IEM)		Not Applicable
xii	Latest updates	Latest updates on the important dates, Amendments, Correspondences, Corrigenda, Clarifications, Changes, Errata, Modifications, Revisions, etc to Tender Specifications will be hosted in BHEL webpage (www.bhel.com -->Tender Notifications →View Corrigendums) and not in the newspapers . Bidders to keep themselves updated with all such information	

- 2.0 The offer shall be submitted as per the instructions of tender document and as detailed in this NIT. Bidders to note specifically that all pages of tender document, including these NIT pages of this particular tender together with subsequent correspondences shall be submitted by them, duly signed & stamped on each page, as part of offer. **Rates/Price including discounts/rebates, if any, mentioned anywhere/in any form in the techno-commercial offer other than the Price Bid, shall not be entertained.**
- 3.0 Unless specifically stated otherwise, bidder shall remit cost of tender and courier charges if applicable, in the form of Demand Draft drawn in favour of Bharat Heavy Electricals Ltd, payable at Power Sector Regional HQ at Nagpur issuing the Tender, along with techno-commercial offer. Bidder may also choose to deposit the Tender document cost by cash at the Cash Office as stated above against sl no iv of 1, on any working day; and in such case copy of Cash receipt is to be enclosed with the Techno Commercial offer. Sale of tender Documents shall not take place on National Holidays, holidays declared by Central or State Governments and BHEL PS HQ at Nagpur, Sundays and second/ last Saturdays
- 4.0 Unless specifically stated otherwise, bidder shall deposit EMD through Demand Draft/Pay Order in favour of Bharat Heavy Electricals Ltd, payable at Nagpur. For other details and for 'One Time EMD' please refer General Conditions of Contract.
- 5.0 **Procedure for Submission of Tenders:** The Tenderers must submit their Tenders to Officer inviting Tender, as detailed below:
- PART-I consisting of 'PART-I A (Techno Commercial Bid)' & 'PART-I B (EMD/COST of TENDER)' in two separate sealed and superscribed envelopes (ENVELOPE-I & ENVELOPE-II)

**BHEL PSWR
Notice Inviting Tender**

Tender Specification No: BHE/PW/PUR/HZRI-ENB/1323

Page 7 of 49

- PART-II (Price Bid) – in sealed and superscribed envelope (ENVELOPE-III)
- One set of tender documents shall be retained by the bidder for their reference

6.0 The contents for ENVELOPES and the superscription for each sealed cover/Envelope are as given below. **(All pages to be signed and stamped)**

Sl no	Description	Remarks
Part-I A		
	ENVELOPE – I superscribed as : PART-I (TECHNO COMMERCIAL BID) TENDER NO : NAME OF WORK : PROJECT: DUE DATE OF SUBMISSION: CONTAINING THE FOLLOWING:-	
i.	Covering letter/Offer forwarding letter of Tenderer.	
ii.	Duly filled-in 'No Deviation Certificate' as per prescribed format to be placed after document under sl no (i) above. Note: <ol style="list-style-type: none"> a. In case of any deviation, the same should be submitted separately for technical & commercial parts, indicating respective clauses of tender against which deviation is taken by bidder. The list of such deviation shall be placed after document under sl no (i) above. It shall be specifically noted that deviation recorded elsewhere shall not be entertained. b. BHEL reserves the right to accept/reject the deviations without assigning any reasons, and BHEL decision is final and binding. <ol style="list-style-type: none"> i). In case of acceptance of the deviations, appropriate loading shall be done by BHEL ii). In case of unacceptable deviations, BHEL reserves the right to reject the tender 	
iii.	Supporting documents/ annexure/ schedules/ drawing etc as required in line with Pre-Qualification criteria. It shall be specifically noted that all documents as per above shall be indexed properly and credential certificates issued by clients shall distinctly bear the name of organization, contact ph no, FAX no, etc.	
iv.	All Amendments/Correspondences/Corrigenda/Clarifications/Changes/ Errata etc pertinent to this NIT.	
v.	Integrity Pact Agreement (Duly signed by the authorized signatory)	If applicable
vi.	Duly filled-in annexures, formats etc as required under this Tender Specification/NIT	
vii.	Notice inviting Tender (NIT)	
viii.	Volume – I A : <u>Technical</u> Conditions of Contract (TCC) consisting of Scope of work, Technical Specification, Drawings, Procedures, Bill of Quantities, Terms of payment, etc	
ix.	Volume – I B : Special Conditions of Contract (SCC)	
x.	Volume – I C : General Conditions of Contract (GCC)	
xi.	Volume – I D : Forms & Procedures	
xii.	Volume – II (UNPRICED – without disclosing rates/price, but mentioning only 'QUOTED' or 'UNQUOTED' against each item	
xiii.	Any other details preferred by bidder with proper indexing.	

PART-I B		
	ENVELOPE – II superscribed as: PART-I (EMD/COST of TENDER) TENDER NO : NAME OF WORK :	

**BHEL PSWR
Notice Inviting Tender**

Tender Specification No: BHE/PW/PUR/HZRI-ENB/1323

Page 8 of 49

	PROJECT: DUE DATE OF SUBMISSION: CONTAINING THE FOLLOWING:-	
i.	1. Earnest Money Deposit (EMD) in the form as indicated in this Tender OR Documentary evidence for 'One Time EMD' with the Power Sector Region of BHEL floating the Tender 2. Cost of Tender (Demand Draft or copy of Cash Receipt as the case may be)	

	PART-II	
	PRICE BID consisting of the following shall be enclosed	
	ENVELOPE-III superscribed as: PART-II (PRICE BID) TENDER NO : NAME OF WORK : PROJECT: DUE DATE OF SUBMISSION: CONTAINING THE FOLLOWING	
i	Covering letter/Offer forwarding letter of Tenderer enclosed in Part-I	
ii	Volume II – PRICE BID (Duly Filled in Schedule of Rates – rate/price to be entered in words as well as figures)	

	OUTER COVER	
	ENVELOPE-IV (MAIN ENVELOPE / OUTER ENVELOPE) superscribed as: TECHNO-COMMERCIAL BID, PRICE BID & EMD TENDER NO: NAME OF WORK: PROJECT: DUE DATE OF SUBMISSION: CONTAINING THE FOLLOWING:	
i	<ul style="list-style-type: none"> o Envelopes I o Envelopes II o Envelopes III 	

SPECIAL NOTE : All documents/ annexures submitted with the offer shall be properly annexed and placed in respective places of the offer as per enclosure list mentioned in the covering letter. BHEL shall not be responsible for any missing documents.

- 7.0 Deviation with respect to tender clauses and additional clauses/suggestions in Techno-commercial bid / Price bid shall NOT be considered by BHEL. Bidders are requested to positively comply with the same.
- 8.0 BHEL reserves the right to accept or reject any or all Offers without assigning any reasons thereof. BHEL also reserves the right to cancel the Tender wholly or partly without assigning any reason thereof. Also BHEL shall not entertain any correspondence from bidders in this matter (except for the refund of EMD).

9.0 Assessment of Capacity of Bidders:

Bidders capacity for executing the job under tender shall be assessed 'LOAD' wise and 'PERFORMANCE' wise as per the following:

- I. **LOAD:** Load takes into consideration **ALL** the contracts of the Bidder under execution with BHEL Regions, irrespective of whether they are similar to the tendered scope or not. The 'Load' is the sum of the unit wise identified packages (refer Table-1) for contracts with BHEL Regions. The cut off month for reckoning 'Load' shall be the month, two (2) months preceding the month corresponding to the 'latest date of bid submission', in the following manner:

(Note: For example if latest bid submission is in Aug 2011, then the 'load' shall be calculated upto and inclusive of June 2011)

- i). Total number of Packages

Total number of Packages in hand = P

Where

- 'P' is the sum of all unit wise identified packages under execution with BHEL Regions as of the cut off month defined above, including packages yet to be commenced, excepting packages which are on HOLD due to reasons not attributable to Bidder..

- II. **PERFORMANCE:** Here 'Monthly Performance' of the bidder for all the packages (**under execution/** executed during the 'Period of Assessment' in all the Power Sector Regions of BHEL) **SIMILAR** to the packages covered under the tendered scope, excepting packages not commenced shall be taken into consideration. The 'Period of Assessment' shall be 6 months preceding the cut off month. The cut off month for reckoning 'Period of Assessment' shall be the month two (2) months preceding the month corresponding to the 'latest date of bid submission', in the following manner:

(Note: For example if 'latest date of bid submission' is in Aug 2011, then the 'performance' shall be assessed for a 6 month period upto and inclusive of June 2011, for all the unit wise identified packages (refer Table I)

- i). Calculation of Overall 'Performance Rating' for 'similar Package/Packages' for the tendered scope under execution at Power Sector Regions for the 'Period of Assessment':

This shall be obtained by summing up the 'Monthly Performance Evaluation' scores obtained by the bidder in all Regions for all the similar Package/packages', divided by the total number of Package months for which evaluation should have been done, as per procedure below:

- a) $P_1, P_2, P_3, P_4, P_5, \dots P_N$ etc be the packages (**under execution/** executed during the 'Period of Assessment' in all Regions) **SIMILAR** to the packages covered under the tendered scope, excepting packages not commenced. Total number of similar packages for all Regions = P_T (i.e $P_T = P_1 + P_2 + P_3 + P_4 + \dots P_N$)
- b) Number of Months 'T₁' for which 'Monthly Performance Evaluation' as per relevant formats, should have been done in the 'Period of Assessment' for the corresponding similar package P₁. Similarly T₂ for package P₂, T₃ for package P₃, etc for the tendered scope. Now calculate cumulative total months 'T_T' for total similar Packages 'P_T' for all Regions (i.e $T_T = T_1 + T_2 + T_3 + T_4 + \dots T_N$)
- c) Sum 'S₁' of 'Monthly Performance Evaluation' Scores (S₁₋₁, S₁₋₂, S₁₋₃, S₁₋₄, S₁₋₅,..... S_{1-N}) for similar package P₁, for the 'period of assessment' 'T₁' (i.e $S_1 = S_{1-1} + S_{1-2} + S_{1-3} + S_{1-4} + S_{1-5} + \dots S_{1-N}$). Similarly S₂ for package P₂ for period T₂, S₃ for package P₃ for period T₃, etc for the tendered scope for all Regions. Now calculate cumulative sum 'S_T' of 'Monthly Performance Evaluation' Scores for total similar Packages 'P_T' for all Regions (i.e 'S_T' = S₁ + S₂ + S₃ + S₄ + S₅ +..... S_N.)

d) Overall Performance Rating 'R_{BHEL}' for the similar Package/Packages (under execution/ executed during the 'Period of Assessment') in all the Power Sector Regions of BHEL):

$$= \frac{\text{Aggregate of Performance scores for all similar packages in all the Regions}}{\text{Aggregate of months for each of the similar package for which performance should have been evaluated in all the Regions}}$$

$$= \frac{S_T}{T_T}$$

e) Bidders to note that the risk of non evaluation or non availability of the 'Monthly Performance Evaluation' reports as per relevant formats is to be borne by the Bidder

f) Table showing methodology for calculating 'a', 'b' and 'c' above

Sl no	Item Description	Details for all Regions							Total
		(i)	(ii)	(iii)	(iv)	(v)	(vi)	(vii)	
1	Similar Packages for all Regions → (under execution/ executed during period of assessment)	P ₁	P ₂	P ₃	P ₄	P ₅	...	P _N	Total No of similar packages for all Regions = P _T ie Sum (Σ) of columns (iii) to (ix)
2	Number of Months for which 'Monthly Performance Evaluation' as per relevant formats should have been done in the 'period of assessment' for corresponding similar Package (as in row 1)	T ₁	T ₂	T ₃	T ₄	T ₅	...	T _N	Sum (Σ) of columns (iii) to (ix) = T _T
3	Monthly performance scores for the corresponding period (as in Row 2)	S _{1-1,} S _{1-2,} S _{1-3,} S _{1-4,} ... S _{1-T1}	S _{2-1,} S _{2-2,} S _{2-3,} S _{2-4,} ... S _{2-T2}	S _{3-1,} S _{3-2,} S _{3-3,} S _{3-4,} ... S _{3-T3}	S _{4-1,} S _{4-2,} S _{4-3,} S _{4-4,} ... S _{4-T4}	S _{5-1,} S _{5-2,} S _{5-3,} S _{5-4,} ... S _{5-T5}	S _{N-1,} S _{N-2,} S _{N-3,} S _{N-4,} ... S _{N-TN}	-----
4	Sum of Monthly Performance scores of the corresponding Package for the corresponding period (as in row-3)	S ₁	S ₂	S ₃	S ₄	S ₅	...	S _N	Sum (Σ) of columns (iii) to (ix) = S _T

ii) Calculation of Overall 'Performance Rating' (R_{BHEL}) in case 'similar Package/Packages' for the tendered scope ARE NOT AVAILABLE, during the 'Period of Assessment':

This shall be obtained by summing up the 'Monthly Performance Evaluation' scores obtained by the bidder in all Regions for ALL the packages, divided by the total number of Package months for which evaluation should have been done. 'R_{BHEL}' shall be calculated subject to availability of 'performance scores' for at least 6 'package months' in the order of precedence below:

- a) 'Period of Assessment.
- b) 12 months preceding the cut-off month
- c) 24 months preceding the cut-off month
- d) 36 months preceding the cut-off month

In case, R_{BHEL} cannot be calculated as above, then Bidder shall be treated as 'NEW VENDOR'. Further eligibility and qualification of this bidder shall be as per definition of 'NEW VENDOR' described in 'Explanatory Notes'

iii) Factor "L" assigned based on Overall Performance Rating (R_{BHEL}) at Power Sector Regions.:

Sl no	Overall Performance Rating (R _{BHEL})	Corresponding value of 'L'
1	=60	NA
2	> 60 and ≤ 65	0.4
3	> 65 and ≤ 70	0.35
4	> 70 and ≤ 75	0.25
5	> 75 and < 80	0.2
6	≥ 80	NA

III. 'Assessment of Capacity of Bidder':

'Assessment of Capacity of Bidder' is based on the Maximum number of packages for which a vendor is eligible, considering the performance scores of similar packages, as below:

Max number of packages $P_{Max} = (R_{BHEL} - 60)$ divided by corresponding value of 'L'
i.e. $(R_{BHEL} - 60)/L$

Note:

- i. In case the value of P_{Max} results in a fraction, the value of P_{Max} is to be rounded off to next whole number
- ii. For $R_{BHEL} = 60$, $P_{Max} = '1'$
- iii. For $R_{BHEL} \geq 80$, there will be no upper limit on P_{Max}

The Bidder shall be considered 'Qualified' as per 'Assessment of Capacity of Bidder' for the subject

Tender if $P \leq P_{Max}$

(where P is calculated as per clause 9.1)

IV. Explanatory note:

- a) Similar package means Boiler or ESP or Piping or Turbine or Civil or Structure or Electrical or CI, etc at the individual level irrespective of rating of Plant, and irrespective of whether the subject tender is a single package or as part of combined/composite packages. Normally Boiler, ESP, Piping, Turbine, Electrical, CI, Civil, Structure, etc is considered individual level of package. For example in case the tendered scope is a Boiler Vertical Package comprising of Boiler, ESP and Power Cycle Piping (i.e the 'identified packages as per Table-1 below), the 'PERFORMANCE' part against sl no II above, needs to be evaluated considering all the identified packages (ie Boiler, ESP and Power Cycle Piping) and finally the Bidder's capacity to execute the tendered scope is assessed in line with III above

**BHEL PSWR
Notice Inviting Tender**

Tender Specification No: BHE/PW/PUR/HZRI-ENB/1323

Page 12 of 49

b) Identified Packages (Unit wise)

Table-1

	Civil	Electrical & CI	Mechanical
	i). Enabling works ii). Pile and Pile Caps iii). Civil Works including foundations iv). Structural Steel Fabrication & Erection v). Chimney vi). Cooling Tower vii). Others (Civil)	i). Electrical ii). CI iii). Others (Elec & CI)	i). Boiler & Aux (All types including CW Piping if applicable) ii). Power Cycle Piping/Critical Piping iii). LP Piping iv). ESP v). Steam Turbine Generator set & Aux vi). Gas Turbine Generator set & Aux vii). Hydro Turbine Generator set & Aux viii). Turbo Blower (including Steam Turbine) ix). Material Handling x). Material Management xi). Material Handling & Material Management xii). Others (Mechanical)

- c) Bidders who have not been evaluated for at least six package months in the last 36 months in the online BHEL system for contractor performance evaluation in BHEL PS Regions, wef July'2010 shall be considered "NEW VENDOR".

A 'NEW VENDOR' shall be considered qualified subject to satisfying all other tender conditions

A 'NEW VENDOR' if awarded a job (of package/packages identified under this clause) shall be tagged as "FIRST TIMER" on the date of first LOI from BHEL.

The "FIRST TIMER" tag shall remain till execution of work for a period of not less than 09 months, from the commencement of work of first package

A Bidder shall not be eligible for the next job as long as the Bidder is tagged as "FIRST TIMER" excepting for the Tenders which have been opened on or before the date of the bidder being tagged as 'FIRST TIMER'.

After removal of 'FIRST TIMER' tag, the Bidder shall be considered 'QUALIFIED' for the future tenders subject to satisfying all other tender conditions including 'Capacity Evaluation of Bidders'.

- d) In the unlikely event of all bidders shortlisted against Technical and Financial Qualification criteria not meeting the criteria on 'Assessment of Capacity of Bidders' detailed above, OR leads to a single tender response on applying the criteria of 'Assessment of Capacity of Bidders' or due to non-approval by Customer, then BHEL at its discretion reserves the right to consider the further processing of the Tender based on the **Overall Performance Rating 'R_{BHEL}'** only, starting from the upper band.

- e) 'Under execution' shall mean works in progress as per the following:

- i. up to Boiler Steam Blowing in case of Steam Generator and Auxiliaries
- ii. upto Synchronisation in case of all other works excepting sl no (i) and (iii)

**BHEL PSWR
Notice Inviting Tender**

Tender Specification No: BHE/PW/PUR/HZRI-ENB/1323

Page 13 of 49

-
- iii. Upto execution of at least 90% of anticipated contract value in case of Civil & Structures (unit wise), Enabling works and upto 90% of material unloading (in tonnage) as per the original contract in case of MM Package.

Note : BHEL at its discretion can extend (or reduce in exceptional cases in line with Contract conditions) the period defined against (i), (ii) and (iii) above, depending upon the balance scope of work to be completed.

- f) Performance evaluation in CL 9 above is applicable to Prime bidder and consortium partner (or Technical tie up partner) for their respective scope of work

- 10.0 Since the job shall be executed at site, bidders must visit site/ work area and study the job content, facilities available, availability of materials, prevailing site conditions including law & order situation, applicable wage structure, wage rules, etc before quoting for this tender. They may also consult this office before submitting their offers, for any clarifications regarding scope of work, facilities available at sites or on terms and conditions.
- 11.0 For any clarification on the tender document, the bidder may seek the same in writing or through e-mail, as per specified format, within the scheduled date for seeking clarification, from the office of the undersigned. BHEL shall not be responsible for receipt of queries after due date of seeking clarification due to postal delay or any other delays. Any clarification / query received after last date for seeking clarification may not be normally entertained by BHEL and no time extension will be given.
- 12.0 BHEL may decide holding of pre-bid discussion [PBD] with all intending bidders as per date indicated in the NIT. The bidder shall ensure participation for the same at the appointed time, date and place as may be decided by BHEL. Bidders shall plan their visit accordingly. The outcome of pre-bid discussion (PBD) shall also form part of tender.
- 13.0 In the event of any conflict between requirement of any clause of this specification/ documents/drawings/data sheets etc or requirements of different codes/standards specified, the same to be brought to the knowledge of BHEL in writing for clarification before due date of seeking clarification (whichever is applicable), otherwise, interpretation by BHEL shall prevail. Any typing error/missing pages/ other clerical errors in the tender documents, noticed must be pointed out before pre-bid meeting/submission of offer, else BHEL's interpretation shall prevail.
- 14.0 Unless specifically mentioned otherwise, bidder's quoted price shall deemed to be in compliance with tender including PBD.
- 15.0 Bidders shall submit Integrity Pact Agreement (Duly signed by authorized signatory who signs in the offer), **if applicable**, along with techno-commercial bid. This pact shall be considered as a preliminary qualification for further participation. **The names and other details of Independent External Monitor (IEM) for the subject tender is as given at point (1) above.**
- 16.0 The Bidder has to satisfy the Pre Qualifying Requirements stipulated for this Tender in order to be qualified. The Price Bids of only those bidders will be opened who will be qualified for the subject job on the basis of satisfying the Pre Qualification Criteria specified in this NIT as per Annexure-I (as applicable), past performance etc. and date of opening of price bids shall be intimated to only such bidders. BHEL reserves the right not to consider offers of parties under HOLD.
- 17.0 In case BHEL decides on a 'Public Opening', the date & time of opening of the sealed PRICE BID shall be intimated to the qualified bidders and in such a case, bidder may depute one authorised representative to witness the price bid opening. BHEL reserves the right to open 'in-camera' the 'PRICE BID' of any or all Unsuccessful/Disqualified bidders under intimation to the respective bidders.
- 18.0 Validity of the offer shall be for **six months** from the latest due date of offer submission (including extension, if any) unless specified otherwise.
- 19.0 BHEL reserves the right to decide the successful bidder on the basis of Reverse Auction process. In such case all qualified bidders will be intimated regarding procedure/ modality for Reverse Auction process prior to Reverse Auction and price will be decided as per the rules for Reverse Auction. .

**BHEL PSWR
Notice Inviting Tender**

Tender Specification No: BHE/PW/PUR/HZRI-ENB/1323

Page 14 of 49

- However, if reverse auction process is unsuccessful as defined in the RA rules/procedures, or for whatsoever reason, then the sealed 'PRICE BIDS' will be opened for deciding the successful bidder. BHEL's decision in this regard will be final and binding on bidder.
- 20.0 On submission of offer, further consideration will be subject to compliance to tender & qualifying requirement and customer's acceptance, as applicable.
- 21.0 In case the bidder is an "Indian Agent of Foreign Principals", 'Agency agreement has to be submitted along with Bid, detailing the role of the agent along with the terms of payment for agency commission in INR, along with supporting documents.
- 22.0 The bidders shall not enter into any undisclosed M.O.U. or any understanding amongst themselves with respect to tender.
- 23.0 Consortium Bidding (or Technical Tie up) shall be allowed only if specified in Pre Qualifying Requirement (PQR) criteria, and in such a case the following shall be complied with:
- 23.1 Prime Bidder and Consortium Partner or partners are required to enter into a consortium agreement with a validity period of six months initially. In case the consortium is awarded the contract, then the Consortium Agreement between the Prime Bidder and Consortium Partner or partners shall be extended till contractual completion period including extension periods if any applicable.
- 23.2 'Stand alone' bidder cannot become a **'Prime Bidder' or a 'Consortium bidder' or 'Technical Tie up bidder' in a consortium (or Technical Tie up) bidding**. Prime bidder shall neither be a consortium partner to other prime bidder nor take any other consortium partners. However, consortium partner may enter into consortium agreement with other prime bidders. In case of non compliance, consortium bids of such Prime bidders will be rejected.
- 23.3 Number of partners for a consortium Bidding (or Technical Tie up) shall be as specified in the PQR
- 23.4 Prime Bidder shall be as specified in the Pre Qualification Requirement, else the bidder who has the major share of work
- 23.5 In order to be qualified for the tender, Prime Bidder and Consortium partner or partners shall satisfy (i) the Technical 'Pre Qualifying Requirements' specified for the respective package, (ii) "Assessment of Capacity of Bidder" as specified in clause 9.0
- 23.6 Prime Bidder shall comply with additional 'Technical' criteria of PQR as defined in 'Explanatory Notes for the PQR'
- 23.7 Prime Bidder shall comply with all other Pre Qualifying criteria for the Tender unless otherwise specified
- 23.8 In case customer approval is required, then Prime Bidder and Consortium Partner or partners shall have to be individually approved by Customer for being considered for the tender.
- 23.9 Prime Bidder shall be responsible for the overall execution of the contract
- 23.10 In case of award of job, Performance shall be evaluated for Prime Bidder and Consortium Partner or partners for their respective scope of work(s) as per prescribed formats
- 23.11 In case the Consortium partner or partners back out, their SDs shall be encashed by BHEL. In such a case, other consortium partner or partners meeting the PQR have to be engaged by the Prime Bidder, and if not, the respective work will be withdrawn and executed on risk and cost basis of the Prime Bidder. The new consortium partner or partners shall submit fresh SDs as applicable.
- 23.12 In case the prime Bidder withdraws, the whole contract shall be considered cancelled and short closed.

- 23.13 After execution of work, the work experience shall be assigned to the Prime Bidder and the consortium partner or partners for their respective scope of work. After successful execution of two similar works with the same consortium partner or partners under direct orders of BHEL, the Prime Bidder shall be eligible for becoming a 'stand alone' bidder for similar works, subject to certification from BHEL about the active involvement of the Prime Bidder for satisfactory execution of the works.
- 23.14 The consortium partner shall submit SD equivalent to 2% of the total contract value in addition to the SD to be submitted by the prime Bidder for the total contract value. In case there are two consortium partners, then each partner shall submit SD equivalent to 1% of the total contract value in addition to the SD to be submitted by the prime Bidder for the total contract value.
- 23.15 In case of a Technical Tie up, all the clauses applicable for the Consortium partner shall be applicable for the Technical Tie up partner also
- 24.0 The bidder shall submit documents in support of possession of 'Qualifying Requirements' duly self certified and stamped by the authorized signatory, indexed and properly linked in the format for PQR. In case BHEL requires any other documents/proofs, these shall be submitted immediately.
- 25.0 The bidder may have to produce original document for verification if so decided by BHEL.
- 26.0 Order of Precedence
In the event of any ambiguity or conflict between the Tender Documents, the order of precedence shall be in the order below:
- a. Amendments/Clarifications/Corrigenda/Errata etc issued in respect of the tender documents by BHEL
 - b. Notice Inviting Tender (NIT)
 - c. Price Bid
 - d. Technical Conditions of Contract (TCC)—Volume-1A
 - e. Special Conditions of Contract (SCC) —Volume-1B
 - f. General Conditions of Contract (GCC) —Volume-1C
 - g. Forms and Procedures —Volume-1D

It may please be noted that guidelines/rules in respect of suspension of business dealings', 'Vendor evaluation format', 'Quality, Safety & HSE guidelines', etc may undergo change from time to time and the latest one shall be followed

for BHARAT HEAVY ELECTRICALS LTD

AGM Pur

Enclosure

1. Annexure-1: Pre Qualifying criteria.
2. Annexure-2: Check List .
3. Annexure-3: Important Information .
4. Other Tender documents as per this NIT.

ANNEXURE - 1

PRE QUALIFYING CRITERIA

JOB	FENCING OF OPEN STORAGE YARD (10,000 SQM) WITH GATE, CLOSED STORAGE SHED FOUNDATION UPTO FFL (15X60M) ETC. INCLUDING ITS INTERNAL/EXTERNAL ELECTRIFICATION, ASSOCIATED CIVIL WORK OF PORTA CABIN COMPLEX AT 4x93.1 MW RUPPL HMD Hazira Project.
TENDER NO	BHE/PW/PUR/HZRI-ENB/1323

SL NO	PRE QUALIFICATION CRITERIA	Bidders claim in respect of fulfilling the PQR Criteria	
		Name and Description of qualifying criteria	Page no of supporting document. Bidder must fill up this column as per applicability
A	Submission of Integrity Pact duly signed (if applicable) (Note: To be submitted by Prime Bidder & Consortium/Technical Tie up partner jointly in case Consortium bidding is permitted, otherwise by the sole bidder)	Not APPLICABLE	
B	<u>Technical</u> Bidder must have successfully completed the Civil work of Construction of Building / Storages Shed / Industrial Building / Infrastructure works in the last seven years as on latest date of offer submission as below. i) Executed single similar work of value not less than of Rs 27 Lakhs OR ii) Executed two similar works each of value not less than of Rs 17 Lakhs OR iii) Executed three similar works each of value not less than of Rs 14 Lakhs.	APPLICABLE	
C-1	<u>Financial TURNOVER</u> Bidders must have achieved an average annual financial turnover (Audited) of Rs 10 Lakhs or more over last three Financial Years (FY) i.e. 2011-2012, 2012-2013, 2013-14 OR 2010-2011, 2011-12 and 2012-13 if Annual Accounts for FY 2013-14 are not audited.	APPLICABLE	
C-2	<u>NETWORTH</u> (only in case of Companies) Net worth of the Bidder based on the latest Audited Accounts as furnished for 'C-1' above should be positive	APPLICABLE	

**BHEL PSWR
Notice Inviting Tender**

Tender Specification No: BHE/PW/PUR/HZRI-ENB/1323

Page 17 of 49

C-3	PROFIT Bidder must have earned cash profit in any one of the three Financial Years as applicable in the last three Financial Years defined in 'C-1 above based on latest Audited Accounts.	APPLICABLE	
D	Assessment of Capacity of Bidder to execute the work as per sl no 9 of NIT (if applicable)	APPLICABLE	By BHEL
E	Approval of Customer (if applicable) Note: Names of bidders (including consortium/Technical Tie up partners in case consortium bidding is permitted) who stand qualified after compliance of criteria A to D shall be forwarded to customer for their approval.	Not APPLICABLE	BY BHEL
F	Price Bid Opening Note: Price Bids of only those bidders shall be opened who stand qualified after compliance of criteria A to E	APPLICABLE	BY BHEL
F	Technical Tie up criteria (if applicable)	NOT APPLICABLE	
<p><u>Explanatory Notes for the PQR (unless otherwise specified in the PQR):</u></p> <ol style="list-style-type: none"> Bidder to submit Audited Balance Sheet and Profit and Loss Account for the respective years as indicated against C-1 above along with all annexures In case audited Financial statements have not been submitted for all the three years as indicated against C-1 above, then the applicable audited statements submitted by the bidders against the requisite three years, will be averaged for three years i.e total divided by three. C-2:-NETWORTH : Shall be calculated based on the latest Audited Accounts as furnished for C-1 above. Net worth = Paid up share capital + Reserves. (Net worth is required to be evaluated in case of companies) C-3:- PROFIT : shall be NET profit (PAT + Non cash expenditure viz depreciation) earned during any one of the three financial years as in C-1 above 'Additional' Criteria in respect of 'Technical' criteria of PQR (as in 'B' above) for Civil, Electrical, CI, unless otherwise specified: <ol style="list-style-type: none"> 1. _____ Bidder should have executed similar work of any one of the following: <ol style="list-style-type: none"> a. _____ One (1) work of value not less than Rs XXX _____ OR b. _____ Two (2) works of not less than Rs YYY _____ OR c. _____ Three (3) works of not less than Rs ZZZ (Value XXX, YYY, ZZZ shall be as indicated by BHEL 2. _____ 'Similar' work for criteria 5 above means <ol style="list-style-type: none"> a. _____ Civil or Structures or Civil & Structures or Chimney respectively as applicable to the tendered scope in respect of 'CIVIL' Works b. _____ Electrical works in respect of 'ELECTRICAL' c. _____ CI works in respect of 'CI' Works d. _____ Material Handling and/or Management works in respect of 'MM' works Time period for achievement of the 'Technical' criteria of PQR (as in 'B' above) will be the last 7 years ending on the 'latest date' of Bid submission 'EXECUTED' means the Vendor should have achieved the criteria specified in the Technical criteria of PQR (as in 'B' above) even if the Contract has not been completed or closed Unless otherwise specified, for the purpose of 'Technical' criteria of PQR (as in 'B' above), the word 'EXECUTED' means: 			

**BHEL PSWR
Notice Inviting Tender**

Tender Specification No: BHE/PW/PUR/HZRI-ENB/1323

Page 18 of 49

1.	"BOILER LIGHT UP" in respect of Boiler & Aux and ESP
2.	"SYNCHRONISATION" in respect of STG/GTG and 'SPINNING' in case of HTG
3.	"STEAM BLOWING COMPLETION" in respect of at least Main Steam Line of Power Cycle Piping
4.	"HYDRAULIC TEST" of the system in respect of Structures, Pressure parts/IBR Piping
5.	"CHARGING" in respect of power Transformers, Bus ducts, HT/LT switchgears
6.	"Completion of RCC Shell and liner (steel or brick as per tendered scope) up to the HEIGHT specified using slip form" in case of RCC Chimney.
7.	Achievement of physical Quantities as per respective PQRs in respect of Civil & Structures and Piling Works
8.	'Readiness for coal Filling" in respect of Bunker Structure Work.
9.	Boiler means HRSG or WHRB or any other types of Steam Generator
10.	Critical/Power Cycle piping means Main Steam, Hot Reheat, Cold Reheat, HP Bypass, LP Bypass lines
11.	For the purpose of evaluation of the PQR, one MW shall be considered equivalent to 3.5TPH where ever rating of HRSG/BOILER is mentioned in MW. Similarly, where ever rating of Gas Turbine is mentioned in terms of Frame size, ISO rating in terms of MW shall be considered for evaluation.
12.	In case the experience/PO/WO certificate enclosed by bidders do not have separate break up prices for the E&C portion of Electrical and CI Works, (i.e. the certificates enclosed are for composite order for supply and erection of Electrical & CI and other works if any), then value of Erection and Commissioning for the Electrical & CI portion shall be considered as 15% of the supply & erection of Electrical & CI, unless otherwise specifically indicated in the PQR.
13.	Scope for capital overhaul of STG shall cover Bearing Inspection work and overhauling of all cylinders of the Turbine unless otherwise specifically indicated in the PQR.
14.	In case the tendered scope is not a Pulverised Fuel Boiler, experience of Oil/Gas Fired Boilers also can be considered unless otherwise specifically indicated in the PQR
15.	The value of work (Experience submitted against PQR B) shall be updated as per the PVC indices for "All India Avg. Consumer Price Index for Industrial Workers" with base month as date of execution (completion of contract/work) and indexed upto two months prior to bid opening month.

BIDDER SHALL SUBMIT ABOVE PRE-QUALIFICATION CRITERIA FORMAT, DULY FILLED-IN, SPECIFYING RESPECTIVE ANNEXURE NUMBER AGAINST EACH CRITERIA AND FURNISH RELEVANT DOCUMENT IN THE RESPECTIVE ANNEXURES IN THEIR OFFER.

**BHEL PSWR
Notice Inviting Tender**

Tender Specification No: BHE/PW/PUR/HZRI-ENB/1323

Page 19 of 49

ANNEXURE - 2

CHECK LIST

NOTE:- Tenderers are required to fill in the following details and no column should be left blank

1	Name and Address of the Tenderer		
2	Details about type of the Firm/Company		
3.a	Details of Contact person for this Tender	Name : Mr/Ms Designation: Telephone No: Mobile No: Email ID: Fax No:	
3.b	Details of alternate Contact person for this Tender	Name : Mr/Ms Designation: Telephone No: Mobile No: Email ID: Fax No:	
4	EMD DETAILS	DD No: Date : Bank : Amount: <u>Please tick (✓) whichever applicable:-</u> ONE TIME EMD / ONLY FOR THIS TENDER	
5	Validity of Offer	TO BE VALID FOR SIX MONTHS FROM DUE DATE	
		APPLICABILITY(BY BHEL)	ENCLOSED BY BIDDER
6	Whether the format for compliance with PRE QUALIFICATION CRITERIA (ANNEXURE-I) is understood and filled with proper supporting documents referenced in the specified format	Applicable	YES / NO
7	Audited profit and Loss Account for the last three years	Applicable/ Not Applicable	YES/NO
8	Copy of PAN Card	Applicable/ Not Applicable	YES/NO
9	Whether all pages of the Tender documents including annexures, appendices etc are read understood and signed	Applicable/ Not Applicable	YES/NO
10	Integrity Pact	Not Applicable	YES/NO
11	Declaration by Authorised Signatory	Applicable/ Not Applicable	YES/NO
12	No Deviation Certificate	Applicable/ Not Applicable	YES/NO
13	Declaration confirming knowledge about Site Conditions	Applicable/ Not Applicable	YES/NO
14	Declaration for relation in BHEL	Applicable/ Not Applicable	YES/NO

**BHEL PSWR
Notice Inviting Tender**

Tender Specification No: BHE/PW/PUR/HZRI-ENB/1323

Page 20 of 49

15	Non Disclosure Certificate	Applicable/ Not Applicable	YES/NO
16	Bank Account Details for E-Payment	Applicable/ Not Applicable	YES/NO
17	Capacity Evaluation of Bidder for current Tender	Applicable/ Not Applicable	YES/NO
18	Tie Ups/Consortium Agreement are submitted as per format	Applicable/ Not Applicable	YES/NO
19	Power of Attorney for Submission of Tender/Signing Contract Agreement	Applicable/ Not Applicable	YES/NO
20	Analysis of Unit rates	Applicable/ Not Applicable	YES/NO

NOTE : STRIKE OFF 'YES' OR 'NO', AS APPLICABLE. TENDER NOT ACCOMPANIED BY THE PRESCRIBED **ABOVE APPLICABLE DOCUMENTS** ARE LIABLE TO BE SUMMARILY REJECTED.

DATE :

AUTHORISED SIGNATORY
(With Name, Designation and Company seal)

IMPORTANT INFORMATION

1. The offers of the bidders who are on the banned list as also the offer of the bidders, who engage the services of the banned firms, shall be rejected. The list of banned firms is available on BHEL web site (www.bhel.com ---> Tender Notification --> List of Banned Firms)
2. All Statutory Requirements as applicable for this project shall be complied with.
3. Please take note of following Revised Tender Clauses:
 - i. Notice Inviting Tender: SI No 9
 - ii. General conditions of Contract: Clause No 1.15.13 (New), Clause No 2.8.3, 2.8.4 and 2.8.5
4. Following Notes are added to Form F- 15 of Volume I D 'Forms & procedures'
 - i. It is only indicative and shall be as per the online format issued by BHEL time to time.
 - ii. No request will be entertained after specified date of the current month w.r.t the changes requested in the scores of immediate previous month.

5. PRICE VARIATION CLAUSE

Price Variation Compensation Clause no. 2.17 of Vol I C GCC shall not be Applicable:

6. OVER RUN COMPENSATION

Over Run Compensation Clause no. 2.12 of Vol I C GCC shall not be Applicable

7. Broad Terms & Conditions of Reverse Auction

In continuation to Clause 19.0 of NIT (Notice Inviting Tender) following are the broad terms and conditions of Reverse Auction is given in Annexure V of NIT:

- 7.1. Against this enquiry for the subject item/ system with detailed scope of supply as per enquiry specifications, BHEL may resort to "REVERSE AUCTION PROCEDURE" i.e., ON LINE BIDDING (THROUGH A SERVICE PROVIDER). The philosophy followed for reverse auction shall be English Reverse (No ties).
- 7.2. BHEL reserves the right to go for Reverse Auction (RA) instead of opening the sealed envelope price bid, submitted by the bidder. This will be decided after techno-commercial evaluation. All bidders to give their acceptance for participation in RA. Non-acceptance to participate in RA may result in non-consideration of their

.....

bids. In case BHEL decides to go for Reverse Auction, only those bidders who have given their acceptance to participate in RA will be allowed to participate in the Reverse Auction. Those bidders who have given their acceptance to participate in Reverse Auction will have to necessarily submit „online sealed bid“ in the Reverse Auction. Non-submission of „online sealed bid“ by the bidder will be considered as tampering of the tender process and will invite action by BHEL as per extant guidelines in vogue.

- 7.3. For the proposed reverse auction, technically and commercially acceptable bidders only shall be eligible to participate.
- 7.4. Those bidders who have given their acceptance for Reverse Auction (quoted against this tender enquiry) will have to necessarily submit ‘online sealed bid’ in the Reverse Auction. Non-submission of ‘online sealed bid’ by the bidder for any of the eligible items for which techno-commercially qualified, will be considered as tampering of the tender process and will invite action by BHEL as per extant guidelines in vogue.
- 7.5. BHEL will engage the services of a service provider who will provide all necessary training and assistance before commencement of on line bidding on internet.
- 7.6. In case of reverse auction, BHEL will inform the bidders the details of Service Provider to enable them to contact & get trained.
- 7.7. Business rules like event date, time, bid decrement, extension etc. also will be communicated through service provider for compliance.
- 7.8. Bidders have to fax the Compliance form (annexure IV) before start of Reverse auction. Without this, the bidder will not be eligible to participate in the event.
- 7.9. In line with the NIT terms, BHEL will provide the calculation sheet (e.g., EXCEL sheet) which will help to arrive at “Total Cost to BHEL” like Packing & forwarding charges, Taxes and Duties, Freight charges, Insurance, Service Tax for Services and loading factors (for noncompliance to BHEL standard Commercial terms & conditions) for each of the bidder to enable them to fill-in the price and keep it ready for keying in during the Auction.
- 7.10. Reverse auction will be conducted on scheduled date & time.
- 7.11. At the end of Reverse Auction event, the lowest bidder value will be known on auction portal.
- 7.12. The lowest bidder has to fax/e-mail the duly signed and filled-in prescribed format for price breakup including that of line items, if required, (Annexure VII) as provided on case-to-case basis to Service provider within two working days of Auction without fail.
- 7.13. In case BHEL decides not to go for Reverse Auction procedure for this tender enquiry, the Price bids and price impacts, if any, already submitted and available with BHEL shall be opened as per BHEL’s standard practice.
- 7.14. Bidders shall be required to read the “Terms and Conditions” section of the auctions site of Service provider, using the Login IDs and passwords given to them by the service provider before reverse auction event. Bidders should acquaint themselves of the “Business Rules of Reverse Auction”, which will be communicated before the Reverse Auction.
- 7.15. If the Bidder or any of his representatives are found to be involved in Price manipulation/ cartel formation of any kind, directly or indirectly by communicating

-
- with other bidders, action as per extant BHEL guidelines, shall be initiated by BHEL and the results of the RA scrapped/ aborted.
- 7.16. The Bidder shall not divulge either his Bids or any other exclusive details of BHEL to any other party.
- 7.17. In case BHEL decides to go for reverse auction, the H1 bidder (whose quote is highest in online sealed bid) may not be allowed to participate in further RA process.

Rev 00
6th
JULY

TECHNICAL CONDITIONS OF CONTRACT (TCC)

BHARAT HEAVY ELECTRICALS LIMITED



TECHNICAL CONDITIONS OF CONTRACT (TCC) CONTENTS

SI No	DESCRIPTION	Chapter	No. OF PAGES
Volume-IA	Part-I: Contract specific details		
1	Project Information	Chapter-I	1
2	Scope of Works	Chapter-II	8
3	Facilities in the scope of Contractor/BHEL (Scope Matrix)	Chapter-III	8
4	T&Ps and MMEs to be deployed by Contractor	Chapter-IV	1
5	T&Ps and MMEs to be deployed by BHEL on sharing basis	Chapter-V	1
6	Time Schedule	Chapter-VI	2
7	Terms of Payment	Chapter-VII	1
8	Taxes and other Duties	Chapter-VIII	1
9	Tender Drawings	Chapter-IX	1

TECHNICAL CONDITIONS OF CONTRACT (TCC)

Chapter -I: Project Information

PROJECT INFORMATION

1.0		Project Information (RUPPL, HMD, Hazira)	
1	Purchaser	:	M/s Reliance Utilities and Power Pvt. Limited
2	Project Title	:	4X93.1 MW STG Packages for CCPP Project
3	Location	:	Village - Mora, Dist-Surat, State-Gujarat(India)
4	Address Detail	:	4x93.1 MW STG Package Reliance Utilities and Power Pvt. Ltd Village – Mora, Dist.- Surat Pin Code- 394510, Gujarat State, India
5	Nearest Railway Station	:	Surat, Gujarat
6	Road Approach	:	SH 6
7	Nearest Air Port	:	Surat
8	Nearest Port	:	Adani Hazira Port Pvt. Ltd.
9	Data of Seismic Design	:	As per IS 1893
10	Average Annual Rainfall	:	1205 mm
11	Ambient Air Temperature (Average)	:	a) Maximum : 36.50 C b) Minimum : 14.20 C:
12	Soil Bearing Capacity	:	20 T / m2
13	Average Relative Humidity	:	50 – 85 %
14	Climatic Condition	:	Tropical Climate

TECHNICAL CONDITIONS OF CONTRACT (TCC)

Chapter - II: Scope of Works

2.0 SCOPE OF WORK

The scope of work comprises of but not limited to the following: -

- 2.0.1 Fencing of Open storage Yard (10000 sqm approx.) with Gate.
- 2.0.2 Construction of Closed storage shed Civil Foundation upto FFL (60m X 15m – 1No.) and Supply and fixing of all required fixtures, fittings, cabling, lighting panels for internal electrification of sheds.
- 2.03 Associating civil work of Port cabin Complex including Port cabin brick pedestal, paving, sanitation and electrification work.

All the above jobs shall be as per BHEL Engineer's instructions, drawings, detailed specification and respective bill of quantities furnished in the Rate Schedule.

2.1 Responsibility of the Contractor

The contractor shall engage all the unskilled, skilled and especially skilled labour including fabricators, welders and fitters etc. and supervisory staff. Only trained and competent personnel with previous experience in the job shall be employed. However, BHEL reserves the right to decide on the suitability of the workers and other personnel who will be employed by the contractor. BHEL reserves the right to insist on removal of any employee of the contractor at any time, if they found him unsuitable. The contractor shall be bound to follow the instruction of BHEL.

2.1.1

All the materials like steel , structural members, foundation bolts, MS bars, painting materials, and necessary electric goods etc. shall be supplied by the contractor as per the specification mentioned in the tender/Indian standard specification. The contractor is required to quote their rates inclusive of cost of all materials, labour, etc. BHEL reserves the right to inspect and reject any material not found satisfactory.

2.2 General

2.2.1

During execution of the job, it is very essential that proper and adequate inspection should be made constantly by the contractor to maintain quality of workmanship and to ensure that deviations from BHEL drawings not exceed the permissible limits, which shall be approved by BHEL. **The contractor shall submit test reports of all materials being procured by them for the job and also offer for inspection by BHEL. All the testing charges shall be borne by the contractor.** BHEL engineer shall carry out the inspection of quality of material being purchased/arranged, quality/composition of materials used during construction work and workmanship. Decision of BHEL engineer shall be binding on the contractor.

TECHNICAL CONDITIONS OF CONTRACT (TCC)

Chapter - II: Scope of Works

2.2.2

Contractor shall furnish the **manufacturers test certificate** for the steel & cement procured by them. Apart from this all the field test shall be arranged by contractor for cement, bricks, coarse & fine aggregates either at site or near by Field Quality Lab. approved by BHEL if so desired by BHEL's engineer. All the expenses in these regards shall be borne by contractor.

Contractor shall procure reinforced/ structural steel & cement from reputed manufacturer & approval for the same shall be obtained from BHEL well in advance before ordering for the materials.

2.2.3

The contractor shall visit the site and ascertain the local conditions, entry and traffic restrictions, all obstructions in the area and also ascertain all site conditions and particularly the sub-soil conditions etc. **The contractor shall carry out the survey to study the properties of soil/sub soil like strength to withstand the weight of structure during all weather conditions without sinking of foundation.** If any of such defects like cracks, sinking of foundation etc. occur after completion of work till the performance guarantee period, it shall be rectified by contractor free of cost including the supply of materials required. No claim shall be entertained on this account under any circumstances from the contractor.

2.2.4

The contractor shall provide and maintain at his own cost pumps and other equipment to keep the work free from water and continue to do so until the handing over of the work. The contractor shall clear all trees, rubbish, vegetation, brickbats etc. And dispense them suitably in allotted areas at his own cost.

2.2.5

The contractor shall take adequate precautions to ensure complete safety and prevention of accidents at site. The safety precautions shall conform to IS codes wherever applicable.

2.2.6

The contractor shall level the site in accordance with the sequence of earth leveling to maintain the proper gradient as per the instruction of BHEL; as soon as construction activity is over. Payment towards this shall be released as per the relevant items available in B.O.Q.

2.2.7

The work though not specifically mentioned either in the drawings or in the tender specification but are needed to complete the work as per site requirement & instruction of Engineer are also in the scope of this contract & to be erected to the entire satisfaction, for which the payment shall be released as per the respective item rate of **Rate Schedule. If the item is not available in the rate schedule the rate shall be derived as per CPWD- DSR-2012 rate schedule latest version with applicable escalation.**

2.2.8

The contractor shall provide and maintain at his own cost all T & P for carry out the work.

TECHNICAL CONDITIONS OF CONTRACT (TCC)

Chapter - II: Scope of Works

2.3

The detailed tentative drawings and specifications for the following works will form part of the tender documents. BHEL reserves the right to modify/alter the tender drawings, if necessary during the actual execution at site.

2.3.1

Standard specifications for various items of work for building and road construction as per the relevant IS-codes (latest edition) shall be applicable for this work. The work has to be executed as per standard specification and drawings to the satisfaction of BHEL. However, the following Drawings/Sketches are to be read along with specifications and shall be treated as in the scope of work.

2.3.2

These drawings are indicative and strictly for tendering purpose, only meant to give an idea to tenderers about nature of job. If any changes in the layout, plan, section, partition, etc. are felt necessary by BHEL Engineer to suit site requirement, the same shall be done by contractor as per revised sketches/drawings given by BHEL engineer. Contractor shall ensure/ascertain the stability, safety of the said work. Any modification/variation from the said drawings, if necessary as suggested by the contractor will have to be approved by BHEL in writing.

2.4 Preparation of actual layout and BOQ as per site condition.

- (a) BOQ & drawing given in tender is tentative only as the tender is prepared on the basis of preliminary information which may vary during execution as per actual site condition. As soon as the area for construction of civil work for PORTA CABIN, closed store shed and open yard etc. is taken over from BHEL/customer, Contractor has to ensure actual layout of office, , closed store shed and open storage yard, etc. after doing detailed survey of site. Contractor shall submit detailed survey report after plotting in graph sheet along with actual BOQ for each & every work - section wise and submit the same to BHEL for further comparison with the respective BOQ. All endeavors have to be made to restrict the quantities as per BOQ except some "exceptional cases" which are very necessary due to site condition. Individual item qty. variation may be allowed up to reasonable extent unless the overall executed value of the contract is within the LOA value. For any variation beyond the total contract value, prior approvals are required from BHEL PSWR HQ before release of payment.
- (b) Item of one Section can be utilized for another Section also (if it is required but not available) being "One Contract". This can be used judiciously to avoid extra items. Measurement of work done shall be recorded in respective section of the item indicating the area of usage.

TECHNICAL CONDITIONS OF CONTRACT (TCC)

Chapter - II: Scope of Works

2.4.1

Excavation of Foundation, Roads and Trenches etc shall be made as per IS specification.

2.4.2

Any filling/loose soil met below the foundation shall be made up with lean cement concrete 1:4:8 mix (min).

2.4.3

Basement and sides of the foundation wall shall be filled in with selected excavated earth including watering, consolidation etc. Complete as per IS specification.

2.4.4

The excess/unutilized suitable earth and debris shall be disposed & leveled to the proposed mentioned area for development. All unusable earth debris, trees, vegetations etc. shall be disposed off at a location embarked by BHEL / Client. Rate quoted for excavation shall be inclusive of such disposal.

2.4.5

Filling under floors / foundations with 100mm/150mm thick layer of compacted selected earth/river sand including watering, consolidation etc. shall be executed as per IS specification and drawings if any. However this can be eliminated in case a hard strata/good stratum is met with in foundation level & PCC shall be done directly in such cases. However this can be decided as per site requirement with discussion with site engineer.

2.4.6

PCC: below foundation and PCC capping: This shall include supplying and placing PCC at all depths below plinth level including form work, curing, all materials, tools and plants and labour complete. Concrete of 1:4:8/1:3:6/1:2:4 grade as defined in IS- 456 with 40mm/20mm and downgraded stone aggregates as per drawing. Nominal mix (volumetric) shall be allowed to use as per the guidelines of IS-456 (latest edition) with min. W/C ratio & cement content as per IS stipulation for moderate condition. Concrete shall be produced by concrete mixer machine & hand mix is generally not acceptable.

However in certain unavoidable circumstances, hand mix shall be permitted with 10% extra cement content as per the discretion of BHEL engineer.

2.4.7

Brick masonry: Brick masonry shall be done by using best quality locally available burnt clay bricks / Fly Ash Lime (FAL) bricks of standard size. Minimum strength of the bricks should not be less than 35 KG/sq. cm. Other quality requirement shall be in line with the relevant IS Code. One-brick thick brickwork shall be constructed as specified, in Cement mortar 1:4 including linking, plumbing, leveling, pacing, joints curing etc. Including all materials, tools, plants and labour complete at all level/elevation.

Rubble masonry: Rubble masonry shall be done by using best quality locally available hard stone (black basalt) in foundation/wall. BHEL should be approved quality of stone before placing in use. Irregular hard stones should be rounded of before use. Maximum size of stone should be between 200 – 230mm.

TECHNICAL CONDITIONS OF CONTRACT (TCC)

Chapter - II: Scope of Works

2.4.8

RCC: RCC 1:2:4 shall be provided for column foundations, pedestal, lintel, sun sheds and roof slab as per IS specification.

2.4.9

Formwork: The formwork should be capable of carrying the dead load of concrete, the reinforcements and the forces of vibration. The form works shall be designed by the contractor and approved by engineer in charge. After sufficient curing period & after attaining adequate strength of concrete the formwork shall be removed with the approval of BHEL engineer. The item of PCC/RCC shall be deemed as completed after removal of forms and required finishing is completed.

2.4.10

Roof cover with FRP/RMP (2.0mm thick) sheet for natural lighting shall be provided with suitable 'J' bolts, GI Cup Washers, GI Plain Washers, and Bitumen Washers etc. Wind ties for protection against lifting of roof by wind etc if any. As per standard practice shall be provided by the contractor.

2.4.11

Two coats of Black tar paint shall be provided for the wooden work used in ceiling as per IS specification.

2.4.12

Structural works:

All structural works like roof truss, columns etc. shall be carried out as per drawing given along with the tender. All Associated Fitting materials shall be paid by weight along with the truss.

2.4.13

Contractor is permitted to get steel truss & other structures fabricated at workshop outside of the plant premises with prior permission of BHEL. In this case contractor has to arrange for shop inspections periodically as required by BHEL Engineer to ensure the quality of fabrication work. Fabricated structures without inspection/certified by BHEL shall not be allowed for erection.

2.4.14

Necessary sanitary and plumbing works shall be provided with necessary water taps and all connections with supply lines/septic tank shall be provided by the contractor for BHEL storage office and open yards. The materials used and the location etc. shall be as per the directions of BHEL engineer.

2.4.15

Septic tanks with soak pit/leaching cesspool shall be provided by the contractor at the location specified by BHEL complete in all respects as per IS specification. (It is suitable for capacity of 25 users as per item rate available in the rate schedule). **The drawing attached with tender is indicative only & any changes required at site shall be done as per the instruction of BHEL Engineer.**

TECHNICAL CONDITIONS OF CONTRACT (TCC)

Chapter - II: Scope of Works

2.5 Fencing work

Barbed Wire Fencing

The fencing shall be with MS angles post **50x50x6 mm size – 2M** high (above G.L.) as instructed by engineer in charge, and fixed at every 3M interval with **PCC 1:3:6, 0.30 M x 0.30 M x 0.45 M deep**. It shall be supported with MS angle struts of ISA 50x50x6 every 30M and all turnings on both sides. Barbed wire shall be 10 horizontal and 2 diagonal and shall conform to IS: 278, shall be made of 2 strands of galvanized twisted 2.5 mm (12.5 gauge) steel wire with 4 point barbs. The barbs shall have a length of not less than 13mm and not more than 18mm. (For further details Refer relevant item of BOQ & Drawings).

2.6 Electrical Installations

2.6.1 General

2.6.1.1

The electrical installation shall generally be carried out in conformity with the requirements of the Indian electricity act, 1910 as amended up to date and the Indian electricity rules, 1956 framed there under and also the relevant regulations of the electric supply authority concerned as well as IS: 732-1963 (revised). **Before commencement of work Contractor has to submit detail electrical layout drawings prepared by experienced & licensed electrical agency/engineer indicating the cable route, internal/external panels, cable sizing, fittings & fixtures etc. in line with the BOQ for Closed storage shed.**

2.6.1.2

Good workmanship is an essential requirement for compliance with the rules in the code. The work shall be carried out under the direct supervision of a person holding a valid certificate of competency issued by the state government concerned for the type of work involved.

2.6.1.3

All out door/external lamps shall have weather proof fittings of design approved by BHEL Engineer so as to effectively prevent the admission of moisture.

2.6.1.4

The distribution fuse boards shall be located as near as possible to the center of the load they are intended to control.

2.6.1.5

All main switches shall be of metal clad enclosed pattern, which shall be fixed at close proximity to the point of entry of supply.

2.6.1.6

Main and branch distribution boards shall be in accordance with Indian standard 732-1963 "code of practice for electrical wiring installation".

2.6.1.7

PVC conduit (concealed type) wiring system should be adopted through out and all conduit pipes/channel shall be conforming to latest IS.

TECHNICAL CONDITIONS OF CONTRACT (TCC)

Chapter - II: Scope of Works

2.6.1.8

Approved and good quality copper wire with adequate current carrying capacity/voltage rating with proper insulation as per IS should be used for the entire electrical wiring/installation.

2.6.1.9

The service connection from outside mains to the switchboard inside the building shall also be carried out by the contractor.

2.7 Earthing

2.7.1

All Earthing system shall be in accordance with IS: 3043-1966 "code of practice for Earthing".

2.7.2

The installation and Earthing shall generally be carried out in accordance with the Indian electricity rules 1956 as amended from time to time and the relevant regulations of the electricity supply authority concerned.

2.7.3

All plugs and sockets shall be of three-pin type, one of the pins being connected to earth.

2.7.4

Bodies of all electrical appliances shall be earthed by the use of three pin plugs. The covers of the regulators if of metallic construction, shall be earthed by means of a separate earth wire. A separate earth wire shall be used for earthing these appliances.

2.7.5

All earth wires and earth continuity conductors shall be of copper/-galvanized iron. They shall be either stranded or solid bars of flat rectangular strips and may be bare, provided, due care is taken to avoid corrosion and mechanical damage to it. Inter connections of earth continuity conductors and main and branch earth wires shall be made in such a way that reliable and good electrical connections are permanently ensured.

2.7.6

The neutral conductor shall not be used as earth wire.

2.7.7

Welded, bolted and clamped joints only are permissible. For stranded conductor, sleeve connectors are permissible. Bolted connectors and their screws shall be protected against any possible corrosion.

2.7.8

The path of the earth wire shall, as far as possible, be out of reach of any person and shall be visible for inspection.

2.7.9

The galvanized iron pipe electrodes shall not be smaller than 38mm internal diameter and shall not be less than 3.5M. In length and shall, as far as possible, be embedded below permanent moisture level and shall be one piece only without any joints.

TECHNICAL CONDITIONS OF CONTRACT (TCC)

Chapter - II: Scope of Works

2.7.10

Dewatering: It is the responsibility of the contractor to engage sufficient dewatering pump (Diesel, electrically operated) of adequate capacity for dewatering of sub-soil, rain water from excavated pit and other localized area and keep the area dry and workable till completion of entire work within their quoted rate.

2.8 Prior Approval from BHEL Engineer

Contractor shall take prior approval from BHEL Engineer for use of Sanitary items, FRP/RMP sheets, PPGI Sheet for roofing, Overhead water tanks, Doors, Windows, ventilators **Type of Cement (OPC/PPC)**, Brick, Steel, structural steel and for other items as specified in respective items description and necessary **manufacturer's test certificate (MTC)** and laboratory test as required by BHEL shall be arranged by contractor within their quoted rate.

TECHNICAL CONDITIONS OF CONTRACT (TCC)
Chapter – III: Facilities in the scope of Contractor/BHEL

Sl.No.	Description PART I	Scope / to be taken care by		Remarks
		BHEL	Bidder	
3.1	ESTABLISHMENT			
3.1.1	FOR CONSTRUCTION PURPOSE:			
a	Open space for closed store (as per availability)	Yes		Location will be finalized after joint survey with owner
b	Open space for storage (as per availability)	Yes		Location will be finalized after joint survey with owner
c	Construction of bidder's office, canteen and storage building including supply of materials and other services		Yes	
d	Bidder's all office equipments, office / store / canteen consumables		Yes	
e	Canteen facilities for the bidder's staff, supervisors and engineers etc		Yes	
f	Fire fighting equipments like buckets, extinguishers etc		Yes	
g	Fencing of storage area, office, canteen etc of the bidder		Yes	
3.1.2	FOR LIVING PURPOSES OF THE BIDDER			
a	Open space for labour colony (as per availability)		Yes	

TECHNICAL CONDITIONS OF CONTRACT (TCC)
Chapter – III: Facilities in the scope of Contractor/BHEL

Sl.No.	Description PART I	Scope / to be taken care by		Remarks
		BHEL	Bidder	
b	Labour Colony with internal roads, sanitation, complying with statutory requirements		Yes	
3.2.0	ELECTRICITY			
3.2.1	Electricity for construction purposes 3 Phase of Voltage 415/440 V (To be specified whether chargeable or free)			FREE
a	Single point source	Yes		At a distance of 500M from site (Distance is only estimated, it may vary up to an extent depending on site condition)
b	Further distribution including all materials, Energy Meter, Protection devices and its service		Yes	
c	Duties and deposits including statutory clearances if applicable		Yes	
3.2.2	Electricity for the office, stores, canteen etc of the bidder (to be specified whether chargeable or free)			Chargeable (Applicable Tariff)
a	Single point source	Yes		At a available distance from site (Distance may vary up to an extent depending on site condition)

TECHNICAL CONDITIONS OF CONTRACT (TCC)
Chapter – III: Facilities in the scope of Contractor/BHEL

Sl.No.	Description PART I	Scope / to be taken care by		Remarks
		BHEL	Bidder	
b	Further distribution including all materials, Energy Meter, Protection devices and its service		Yes	
c	Duties and deposits including statutory clearances if applicable		Yes	
3.2.3	Electricity for living accommodation of the bidder's staff, engineers, supervisors etc.	Yes		Chargeable (Applicable Tariff)
a	Single point source	Yes		At a available distance from site (Distance may vary up to an extent depending on site condition)
b	Further distribution including all materials, Energy Meter, Protection devices and its service		Yes	
c	Duties and deposits including statutory clearances if applicable		Yes	
3.3.0	WATER SUPPLY			
3.3.1	For construction purposes: (to be specified whether chargeable or free)	Yes		FREE

TECHNICAL CONDITIONS OF CONTRACT (TCC)
Chapter – III: Facilities in the scope of Contractor/BHEL

Sl.No.	Description PART I	Scope / to be taken care by		Remarks
		BHEL	Bidder	
a	Making the water available at single point		Yes	
b	Further distribution as per the requirement of work including supply of materials and execution		Yes	
3.3.2	<u>Water supply for bidder's office, stores, canteen etc.</u>			
a	Making the water available at single point		Yes	
b	Further distribution as per the requirement of work including supply of materials and execution		Yes	
3.3.3	<u>Water supply for Living Purpose</u>		Yes	
a	Making the water available at single point		Yes	
b	Further distribution as per the requirement of work including supply of materials and execution		Yes	
3.4.0	LIGHTING			
a	For construction work (supply of all the necessary materials) 1. At office/storage area 2. At the preassembly area 3. At the construction site /area		Yes	

TECHNICAL CONDITIONS OF CONTRACT (TCC)
Chapter – III: Facilities in the scope of Contractor/BHEL

Sl.No.	Description PART I	Scope / to be taken care by		Remarks
		BHEL	Bidder	
b	For construction work (execution of the lighting work/ arrangements) 1. At office/storage area 2. At the preassembly area 3. At the construction site /area		Yes	
c	Providing the necessary consumables like bulbs, switches, etc during the course of project work		Yes	
d	Lighting for the living purposes of the bidder at the colony / quarters		Yes	
3.5.0	COMMUNICATION FACILITIES FOR SITE OPERATIONS OF THE BIDDER			
a	Telephone, fax, internet, intranet, e-mail etc.		Yes	
3.6.0	COMPRESSED AIR wherever required for the work			Not Required
3.7.0	Demobilization of all the above facilities		YES	

TECHNICAL CONDITIONS OF CONTRACT (TCC)
Chapter – III: Facilities in the scope of Contractor/BHEL

Sl.No.	Description PART I	Scope / to be taken care by		Remarks
		BHEL	Bidder	
3.8.0	TRANSPORTATION			
a	For site personnel of the bidder		Yes	
b	For bidder's equipments and consumables (T&P, Consumables etc)		Yes	

TECHNICAL CONDITIONS OF CONTRACT (TCC)
Chapter – III: Facilities in the scope of Contractor/BHEL

SI.No	Description PART II 3.9.0 ERECTION FACILITIES	Scope / to be taken care by		Remarks
		BHEL	Bidder	
3.9.1	Engineering works for construction:			NOT APPLICABLE
a	Providing the erection/constructions drawings for all the equipments covered under this scope	Yes		For Details PI refer Chapter-II-
b	Drawings for construction methods	Yes	Yes	In consultation with BHEL
c	As-built drawings – where ever deviations observed and executed and also based on the decisions taken at site- example – routing of small bore pipes			NOT APPLICABLE
d	Shipping lists etc for reference and planning the activities			NOT APPLICABLE
e	Preparation of site erection schedules and other input requirements		Yes	In consultation with BHEL
f	Review of performance and revision of site erection schedules in order to achieve the end dates and other commitments	Yes	Yes	In consultation with BHEL

TECHNICAL CONDITIONS OF CONTRACT (TCC)
Chapter – III: Facilities in the scope of Contractor/BHEL

SI.No	Description PART II 3.9.0 ERECTION FACILITIES	Scope / to be taken care by		Remarks
		BHEL	Bidder	
g	Weekly erection schedules based on SI.No. e		Yes	In consultation with BHEL
h	Daily erection / work plan based on SL No. g		Yes	In consultation with BHEL
i	Periodic visit of the senior official of the bidder to site to review the progress so that works are completed as per schedule. It is suggested this review by the senior official of the bidder should be done once in every two months.		Yes	
j	Preparation of pre-assembly bay			NOT APPLICABLE
k	Laying of racks for gantry crane if provided by BHEL or brought by the contractor/bidder himself			NOT APPLICABLE
L	Arranging the materials required for preassembly			NOT APPLICABLE

TECHNICAL CONDITIONS OF CONTRACT (TCC)
Chapter – IV: T&Ps and MMEs to be deployed by Contractor

A: TOOL & PLANTS

DESCRIPTION
1) Concrete Mixture -1 Nos. 2) Vibrators- 2 Nos . 3) Leveling instrument with calibration certificate as per required 4) Theodolite with calibration certificate as per required 5) Shuttering materials as per requirement 6) Cube moulds required nos and testing arrangement 7) Slump testing cone as required 8) Pump with Motor required for curing 9) Diesel/Petrol/Electric Pump set (2.5 HP)-1 No. 10) Electric Water Pump (1.5HP)-1 No. 11) Welding Transformer-1Nos. 12) Gas cutting Set- 1 Nos. 13) Drilling Machine- 1 Nos. 14) JCB- 1No. 15) Tractor- Trailer- 1 No.
NOTE The above list is only indicative and not exhaustive. Arrangement for any other T and P required for completion of the job shall be the responsibility of the contractor and shall be arranged by him.

B: MEASURING AND MONITORING DEVICES (MMD):

AS PER REQUIREMENT TO BE FINALIZED AT SITE.

NOTE:

THIS ABOVE LIST IS ONLY INDICATIVE AND NEITHER EXHAUSTIVE NOR LIMITING. QUANTITIES INDICATED ABOVE ARE ONLY THE MINIMUM REQUIRED. CONTRACTOR SHALL DEPLOY ALL NECESSARY T&P TO MEET THE SCHEDULES & AS PRESCRIBED BY BHEL ENGINEER AND REQUIRED FOR COMPLETION OF WORK.

TECHNICAL CONDITIONS OF CONTRACT (TCC)
**Chapter – V: T&Ps and MMEs to be deployed by BHEL on sharing
basis**

BHEL WILL NOT PROVIDE ANY MATERIAL OR ANY T & P's FOR THIS WORK

TECHNICAL CONDITIONS OF CONTRACT (TCC)

Chapter – VI: Time Schedule

6.1 TIME SCHEDULE & MOBILIZATION

6.1.1 INITIAL MOBILIZATION AND TENTATIVE SCHEDULE

Contractor shall reach site, make his site establishment and be ready to commence the work within two weeks from the date of fax Letter of Intent or as per directions of Construction Manager/ Project Manager of BHEL.

The contractor has to subsequently augment his resources in such a manner that the entire related works are completed to achieve the following **tentative** schedule:

Milestone activities - Break up activities completion period:

SL.N O.	MILESTONE ACTIVITY	PERIOD
1	Fencing of Open storage Yard (10000 sqm approx.) with Gate	Within ONE (01) month from the date of first excavation at site
2	Construction of Closed storage shed Civil Foundation upto FFL (60m X 15m – 1No.).	Within two (02) month from the date of first excavation at site
3	Associated Civil work of Porta cabin Complex	Within one (1) months from the date of first excavation at site.
6	Associated Electrical works of Closed storage shed- 1 Nos.	After Erection of Pre-Fab Structure. three (03) months from the date of first excavation at site

THE OVERALL CONTRACT PERIOD SHALL BE **3 (THREE) MONTHS**.

6.1.2

In order to meet above schedule and other intermediate targets/activities as set by BHEL Engineer In charge at site, to meet customer requirements/project schedule, contractor shall arrange all necessary resources and work force in consultation with BHEL engineer at site to under take works concurrently in all possible fronts as made available to contractor.

CONTRACTOR SHALL NOTE THAT INDIVIDUAL MILESTONES AS ABOVE SHALL BE ACHIEVED AS PER SCHEDULE FURNISHED ABOVE. THE DATE OF START OF FIRST EXCAVATION SHALL BE RECKONED AS THE START OF CONTRACT PERIOD FOR THIS PURPOSE.

THE CONTRACTOR SHALL REACH SITE AND ESTABLISH HIS SITE OFFICE AND MOBILIZE NECESSARY RESOURCES WELL IN ADVANCE OF ACTUAL COMMENCEMENT

TECHNICAL CONDITIONS OF CONTRACT (TCC)

Chapter – VI: Time Schedule

OF THE CONTRACT TIME SCHEDULE AS PER DIRECTIONS OF BHEL ENGINEER. THE DATE OF COMMENCEMENT FOR THE PURPOSE OF CLAUSE.

DATE OF START OF WORK SHALL BE THE DATE ON WHICH FIRST EXCAVATION WORK IS STARTED.

The contractor shall complete all the work in the scope of this contract within the contract period.

TECHNICAL CONDITIONS OF CONTRACT (TCC)

Chapter-VII: Terms of Payment

Stages of Progressive Payments

The percentage of payment for progressive completion of work in various categories of work shall be as under:

The RA bill payment shall be made as made as per CI no 10.0 of Chapter –X of SCC (page-44)

QUANTITY VARIATION

GCC Clause No. 2.14 (Quantity Variation) ,Page No. 23 is modified as under for this contract

2.14.1

The quoted rates shall remain firm irrespective of any variations in the individual quantities. No compensation becomes payable in case the variation of the final executed contract value is within the limits of Plus (+) or Minus (-) 30 % of awarded contract value.

2.14.2

All other condition as per clause No. 2.14.2 shall remain unchanged.

PRICE VARIATION COMPENSATION

GCC Clause No. 2.17 for PVC shall not be applicable for this contract.

TECHNICAL CONDITIONS OF CONTRACT (TCC)

Chapter-VIII: Taxes and Other Duties

8.0 TAXES, DUTIES, LEVIES (Consolidated Rev 03 dated 09/04/2013)

8.1 'Enabling Works'

The contractor shall pay all (save the specific exclusions as enumerated in this contract) taxes, fees, license charges, deposits, duties, tools, royalty, commissions or other charges which may be levied on the input goods & services consumed and output goods & services delivered in course of his operations in executing the contract. In case BHEL is forced to pay any of such taxes, BHEL shall have the right to recover the same from his bills or otherwise as deemed fit. (i.e. **rates quoted by bidder shall be inclusive of Service Tax, VAT/WCT and all other taxes and duties**)

However, Since the proposed work is in the nature of 'Works Contract service' as per Service tax law, Hence, For non-corporate contractors being Individual, HUF, Proprietary Firm, Partnership Firm or Association of Persons (AOP), BHEL shall recover the applicable Service Tax under reverse charge mechanism from the contractor and remit the same with the Government as per the provisions of Law. Necessary advice/confirmation of remittance shall be issued to the contractor. The contractor shall not be eligible for any refund/reimbursement of such service tax from BHEL. It shall be the responsibility of the contractor to submit proper invoice giving all the requisite details as per Service Tax Law for the determination of the service tax liability of BHEL under reverse charge mechanism. BHEL reserves the right to determine such liability based on the invoice submitted by the contractor or otherwise independently and remittance of the same with the Government.

8.2 New Taxes/Levies

In case the Government imposes any new levy/tax on the output service/ goods/work after award of the contract, the same shall be reimbursed by BHEL at actual.

In case any new tax/levy/duty etc. becomes applicable after the date of Bidder's offer, the Bidder/Contractor must convey its impact on his price duly substantiated by documentary evidence in support of the same **before opening of Price Bid**. Claim for any such impact after opening the Price Bid will not be considered by BHEL for reimbursement of tax or reassessment of offer.

No reimbursement/recovery on account of increase/reduction in the rate of taxes, levies, duties etc. on input goods/services/work shall be made. Such impact shall be taken care of by the Price Variation/Adjustment Clause (PVC) if any. In case PVC is not applicable for the contract, Bidder has to make his own assessment of the impact of future variation if any, in rates of taxes/duties/ levies etc. in his price bid.

TECHNICAL CONDITIONS OF CONTRACT (TCC)

Chapter-IX DRAWINGS

The drawings are hosted in web which are tentative and strictly for tender purpose only. Changes in the drawing as per site requirement will be intimated during execution.

These drawings are the property of BHEL and should not be made use of by the contractor except for the purpose of implementing this contract. All these drawings should be returned to BHEL on completion of the work.

The interpretation of BHEL engineer regarding the details shown in the drawing shall be final, conclusive and binding.

These drawings are for tendering purpose. The work shall be executed with the approval of drawings by BHEL during execution.

DATE

SIGNATURE OF TENDERER WITH SEAL

THE INFORMATION ON THIS DOCUMENT IS THE PROPERTY OF NEW LIFE STEEL STRUCTURES. IT MUST NOT BE USED DIRECTLY OR INDIRECTLY IN ANY WAY DETRIMENTAL TO THE INTEREST OF THE COMPANY.

NSW

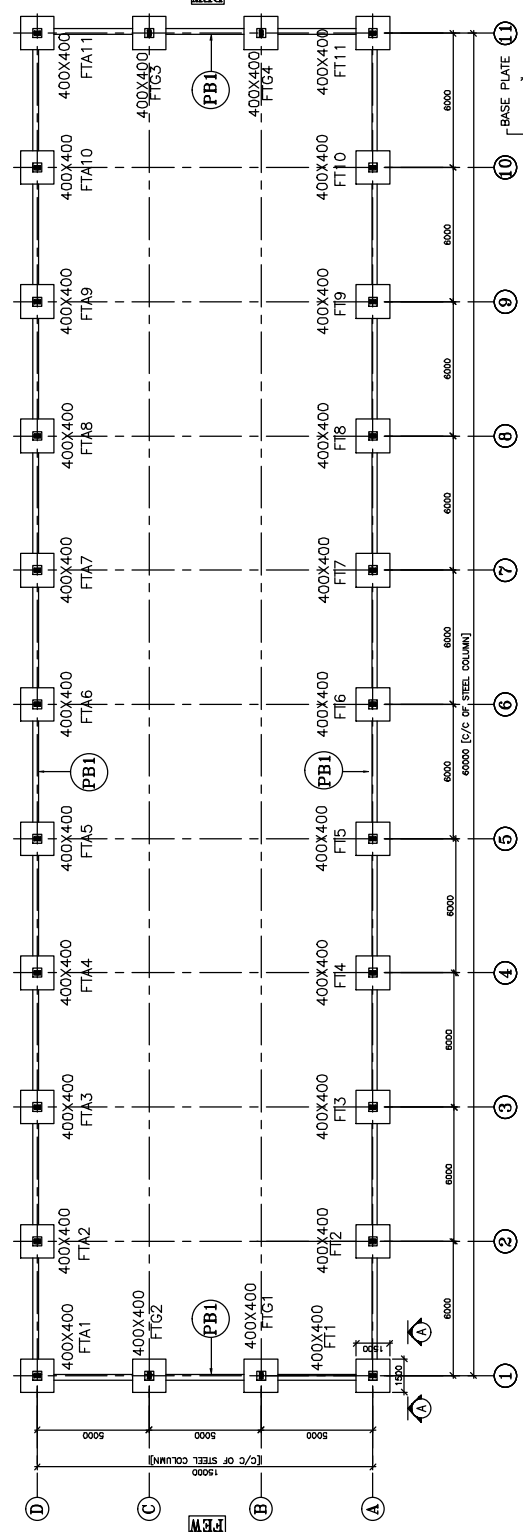

COLUMN LAY OUT & FOUNDATION PLAN OF CLOSED SHED

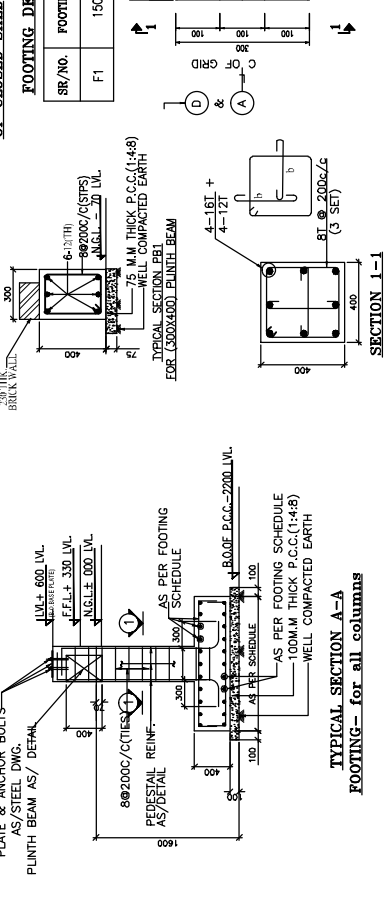

TYPICAL SECTION A-A FOOTING - for all columns

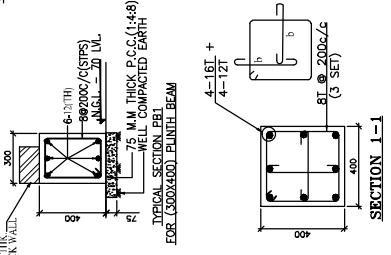

SECTION B-B

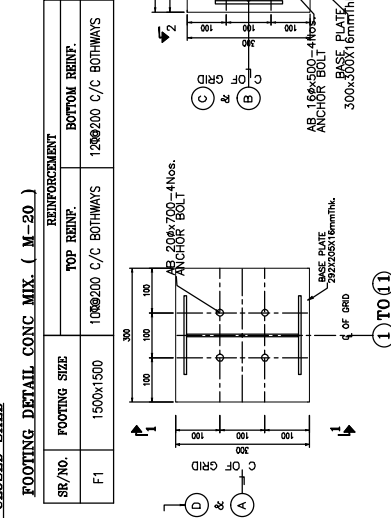

DETAIL I-I

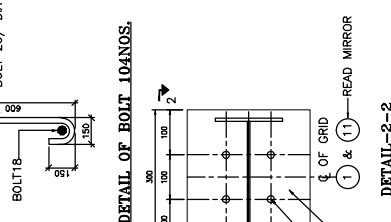

DETAIL I-I

NOTES

1. ALL DIMENSIONS ARE IN MILLIMETERS & ALL UNITS ARE IN METRIC UNITS UNLESS OTHERWISE SPECIFIED.
2. ALL DIMENSIONS ARE TO FACE UNLESS OTHERWISE SPECIFIED.
3. ALL DIMENSIONS ARE TO FACE UNLESS OTHERWISE SPECIFIED.
4. ALL DIMENSIONS ARE TO FACE UNLESS OTHERWISE SPECIFIED.
5. ALL DIMENSIONS ARE TO FACE UNLESS OTHERWISE SPECIFIED.
6. ALL DIMENSIONS ARE TO FACE UNLESS OTHERWISE SPECIFIED.
7. ALL DIMENSIONS ARE TO FACE UNLESS OTHERWISE SPECIFIED.
8. ALL DIMENSIONS ARE TO FACE UNLESS OTHERWISE SPECIFIED.
9. ALL DIMENSIONS ARE TO FACE UNLESS OTHERWISE SPECIFIED.
10. ALL DIMENSIONS ARE TO FACE UNLESS OTHERWISE SPECIFIED.
11. ALL DIMENSIONS ARE TO FACE UNLESS OTHERWISE SPECIFIED.
12. ALL DIMENSIONS ARE TO FACE UNLESS OTHERWISE SPECIFIED.

LEGEND

- 1. UN-DEVELOPMENT LENGTH
- 2. TOP OF STEEL
- 3. TOP OF CONCRETE
- 4. TOP OF BEAM
- 5. BOTTOM OF BEAM
- 6. FINISH FLOOR FINISH
- 7. FINISH CONCRETE SLAB
- 8. FINISH CONCRETE SLAB
- 9. FINISH CONCRETE SLAB
- 10. FINISH CONCRETE SLAB
- 11. FINISH CONCRETE SLAB
- 12. FINISH CONCRETE SLAB

REINFORCEMENT SCHEDULE

ITEM	DESCRIPTION	QUANTITY	UNIT
1	400X400mm COLUMN	11	NO.
2	400X400mm FOOTING	11	NO.
3	8Ø200C/C TOP REINFORCEMENT	11	M
4	8Ø200C/C BOTTOM REINFORCEMENT	11	M
5	4Ø12T PLINTH BEAM	11	M
6	4Ø12T PEDESTAL REINFORCEMENT	11	M

REINFORCEMENT SCHEDULE

ITEM 1: 400X400mm COLUMN

ITEM 2: 400X400mm FOOTING

ITEM 3: 8Ø200C/C TOP REINFORCEMENT

ITEM 4: 8Ø200C/C BOTTOM REINFORCEMENT

ITEM 5: 4Ø12T PLINTH BEAM

ITEM 6: 4Ø12T PEDESTAL REINFORCEMENT

REINFORCEMENT SCHEDULE

ITEM 7: 12Ø200 C/C BOTHWAYS TOP REINFORCEMENT

ITEM 8: 12Ø200 C/C BOTHWAYS BOTTOM REINFORCEMENT

ITEM 9: 4Ø12T ANCHOR BOLTS

REINFORCEMENT SCHEDULE

ITEM 10: 12Ø200 C/C BOTHWAYS TOP REINFORCEMENT

ITEM 11: 12Ø200 C/C BOTHWAYS BOTTOM REINFORCEMENT

ITEM 12: 4Ø12T ANCHOR BOLTS

REINFORCEMENT SCHEDULE

ITEM 13: 12Ø200 C/C BOTHWAYS TOP REINFORCEMENT

ITEM 14: 12Ø200 C/C BOTHWAYS BOTTOM REINFORCEMENT

ITEM 15: 4Ø12T ANCHOR BOLTS

REINFORCEMENT SCHEDULE

ITEM 16: 12Ø200 C/C BOTHWAYS TOP REINFORCEMENT

ITEM 17: 12Ø200 C/C BOTHWAYS BOTTOM REINFORCEMENT

ITEM 18: 4Ø12T ANCHOR BOLTS

REINFORCEMENT SCHEDULE

ITEM 19: 12Ø200 C/C BOTHWAYS TOP REINFORCEMENT

ITEM 20: 12Ø200 C/C BOTHWAYS BOTTOM REINFORCEMENT

ITEM 21: 4Ø12T ANCHOR BOLTS

IF ANY DOUBT ASK.

ANY DISCREPANCY IF THERE SHOULD BE BROUGHT TO OUR NOTICE BEFORE EXECUTION USE M-20 GRADE CONCRETE

STAMP AND SIGN

PROJECT: MIS BHARAT HEAVY ELECTRICALS LTD.

SITE: COMMANDING FOR ALL SHEDS

DATE: 25.01.11

SCALE: 1:1

REVISION:

NO.	ISSUED FOR APPROVAL	DATE	DRAWN	CHECKED	AMOUNT	DATE	FILE	SHEET	OF
1		25.01.11							

FRAMING PLAN AT FOUNDATION

SIZE: 15m x 60m x 5.25m HI.

NEW LIFE STEEL STRUCTURES

Level: 0.000m

100% (As per drawing)

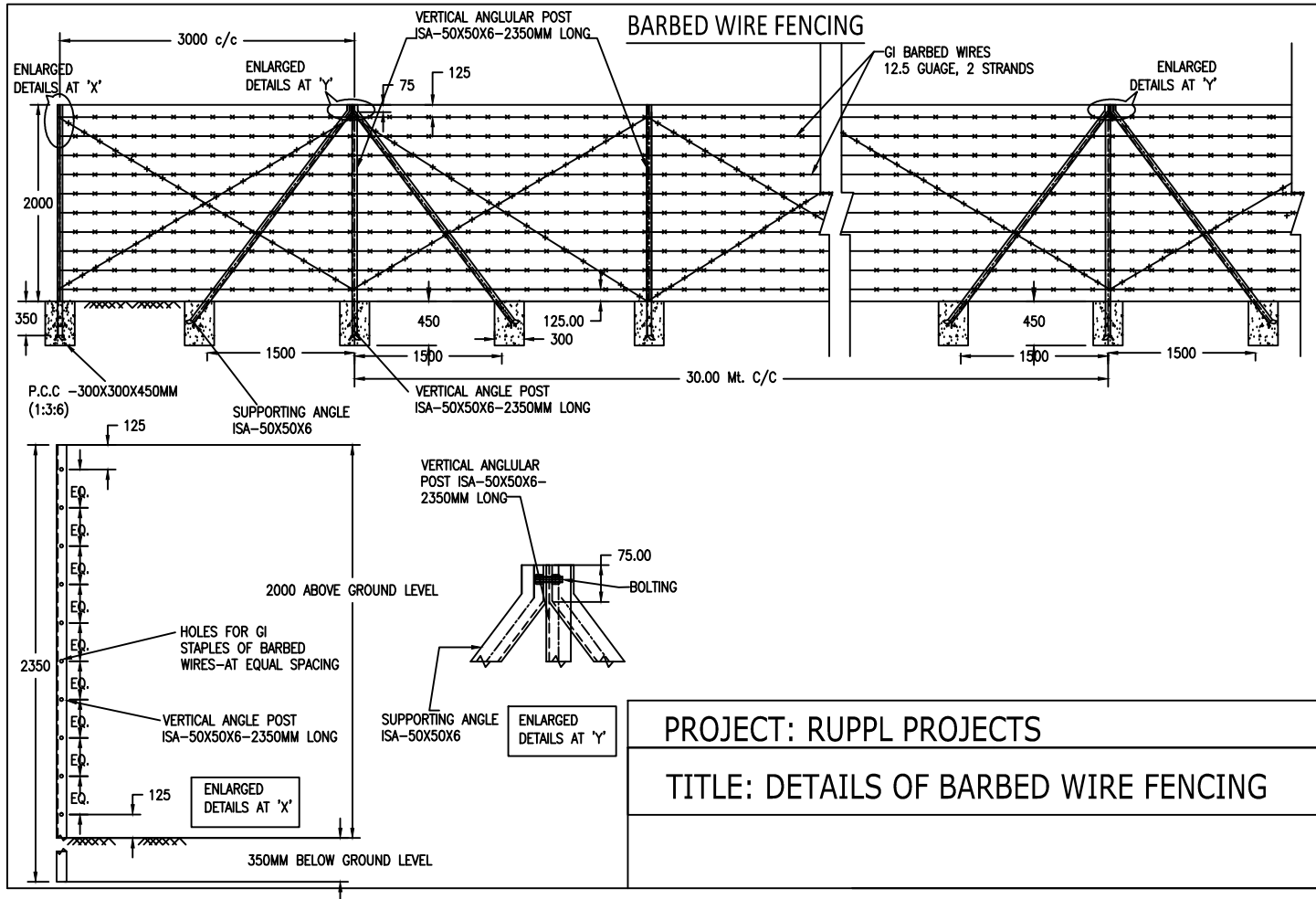

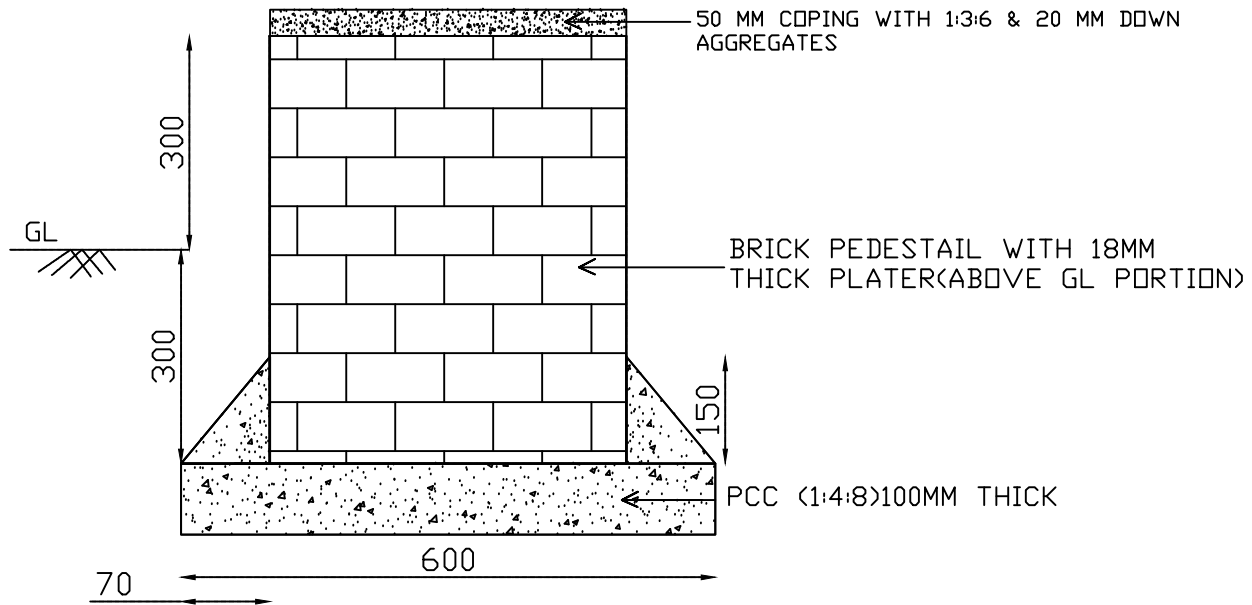

CROSS SECTION OF BRICK PEDESTAIL BLOCK (460MM X 460MM X 600MM DEPTH) BLOCK

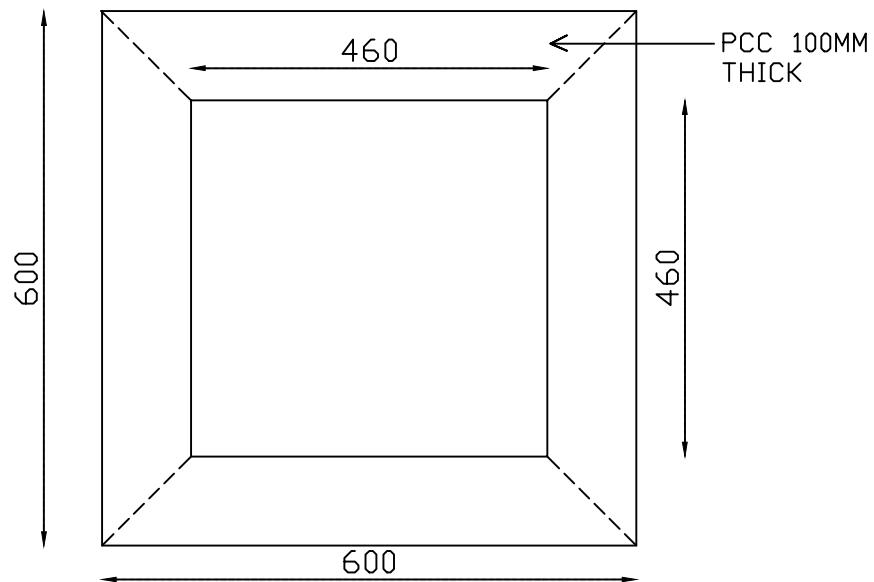

PLAN

DRG. NO.: BHEL/PW/PO-01

NOTE:-

- 1) PCC & BRICK WORK TO BE PAID UNDER RELEVANT ITEM IN BOQ
- 2) ALL DIMENSIONS ARE IN 'MM'.

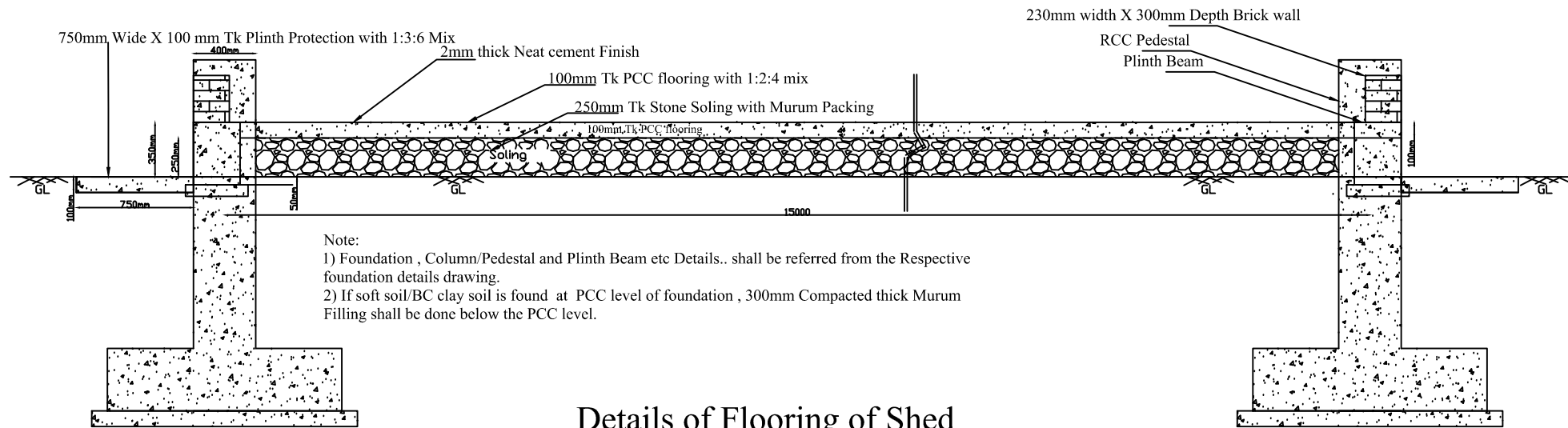

Details of Flooring of Shed

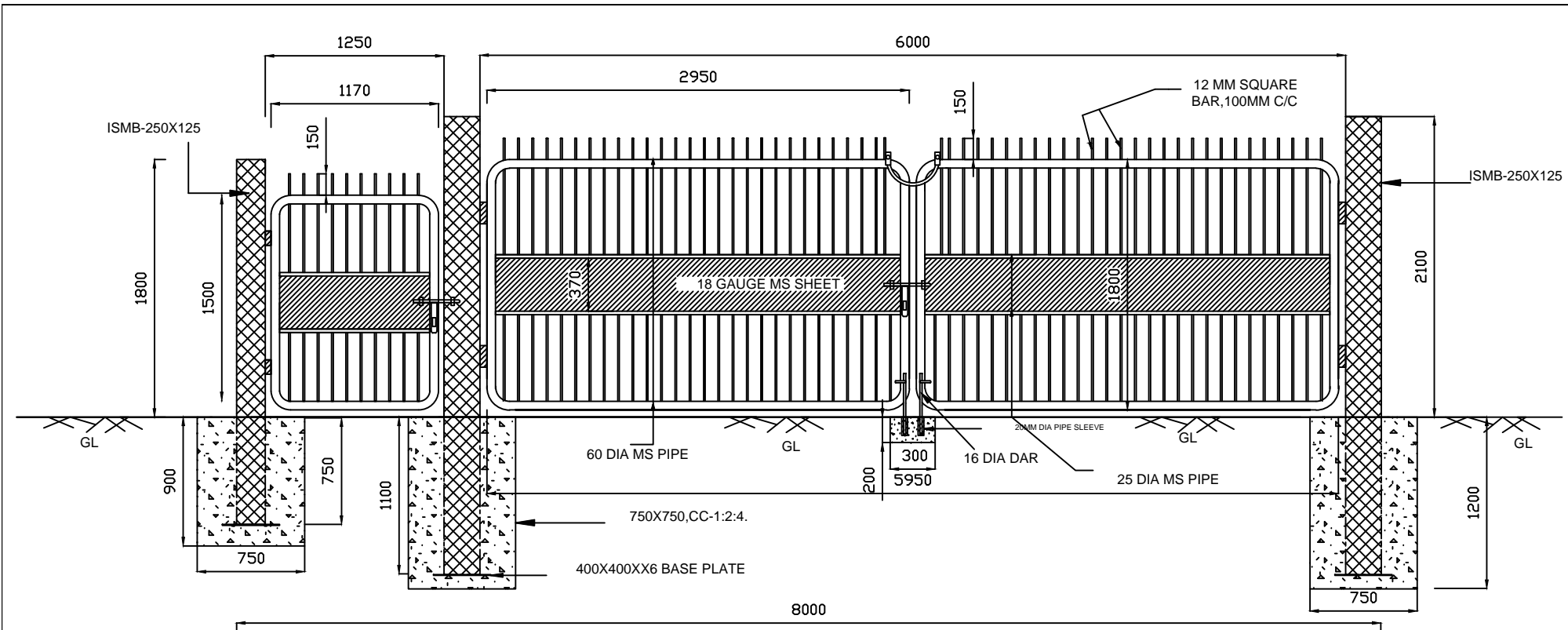

- NOTE:
- 1) ALL DIMENSIONS ARE IN 'MM'.
 - 2) CONCRETE FOR POST FOUNDATION-CC-1:2:4.
 - 3) PANEL: 2950 X 1800.
 - 4) GAP BETWEEN EARTH TO PANAL - 100MM.
 - 5) TOTAL WEIGHT OF GATE - 750 KG (APPROX)

PROPOSED MS PIPE GATE

PROJECT :- RUPPL PROJECTS

TITLE :- PROPOSED MS PIPE GATE

DRG NO. :- BHE/PW/GATE

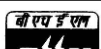
OWNER :-  BHEL-PSWR
NAGPUR