

**TANGEDCO
2X660 MW ENNORE SEZ STPP
AT ASH DYKE OF NCTPS, CHENNAI**

**TECHNICAL SPECIFICATION
FOR SELF CLEANING STRAINERS (SCS)**

Specification No. : PE-TS- 412-165-N003 (REV. 0)

VOLUME -IIB

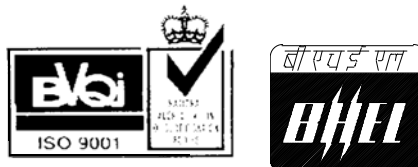

**BHARAT HEAVY ELECTRICALS LIMITED
POWER SECTOR
PROJECT ENGINEERING MANAGEMENT
PPEI BLDG., SEC-16A, PLOT NO. 25
NOIDA – 201301 (UP)**

	TITLE : TECHNICAL SPECIFICATION FOR SELF CLEANING STRAINERS (SCS) PREAMBLE	SPEC. NO. PE-TS- 412-165-N003	
		VOLUME : II B	
		REV. NO. 0	DATE :16.06.15
		SHEET 1 OF 2	

1.0 The tender document contains three (3) volumes. The bidder shall meet the requirements of all the three volumes.

1.1 **Volume -I CONDITIONS OF CONTRACT**

This consists of four parts as below :

Volume - I A : This part contains instructions to bidders for making bids to BHEL.

Volume - I B : This part contains general commercial conditions of the tender and include provision that vendor shall be responsible for the quality of item supplied by their sub-vendors.

Volume - I C : This part contains special conditions of contract.

Volume - I D : This part contains commercial conditions for erection and commissioning site work, as applicable.

1.2 **Volume - II TECHNICAL SPECIFICATIONS**

Technical requirements are stipulated in Volume II which comprises of :

Volume - II A : General Technical Conditions

Volume - II B : Technical specification including drawings, if any

1.2.1 **Volume - II B :**

This volume is sub-divided into following sections:

Section - A : This section outlines the scope of enquiry.

Section - B : This section provides "Project Information"

Section - C : This section indicates technical requirements specific to the contract, not covered in Section-D.

Section - D : This section comprises of standard technical specifications of equipments complete with data sheet A & B.

Data sheet-A specifies data and other requirements pertaining to the equipment.

Data sheet - B specifies data to be filled by the bidder (Data Sheet B is contained in Volume - III)

	TITLE : TECHNICAL SPECIFICATION FOR SELF CLEANING STRAINERS (SCS) PREAMBLE	SPEC. NO. PE-TS- 412-165-N003	
		VOLUME : II B	
		REV. NO. 0	DATE :16.06.15
		SHEET 2 OF 2	

1.2.2 **Volume - III TECHNICAL SCHEDULES**

- 1.0 This volume contains technical schedules and Data Sheets - B, which are to be duly filled by the bidder and the same shall be furnished with the technical bid as per instructions given in Document No.PES-100-901 in Volume-III.
- 2.0 The requirements mentioned in Section C/Data Sheets-A of Section-D shall prevail and govern in case of conflict between the same and the corresponding requirements mentioned in the descriptive portion in Section -D.



TITLE : TECHNICAL SPECIFICATION
FOR
SELF CLEANING STRAINERS (SCS)

SPEC. NO. PE-TS-412-165-N003

VOLUME : II B

SECTION : A

REV. NO. 0

DATE : 16.06.15

SHEET 1 of 1

INDEX

SECTION	TITLE
A	SCOPE OF ENQUIRY
B	PROJECT INFORMATION
C	SPECIFIC REQUIREMENTS
C1	SPECIFIC TECHNICAL REQUIREMENTS FOR SELF CLEANING STRAINERS.
C2	SPECIFIC TECHNICAL REQUIREMENTS (ELECTRICAL)
C3	SPECIFIC TECHNICAL REQUIREMENTS (C&I)
D	STANDARD TECH. SPECIFICATIONS
D1	SELF CLEANING STRAINER <ul style="list-style-type: none">◆ STANDARD TECHNICAL SPEC.NO. PE-TS-999-165-N002◆ DATA SHEET-A◆ QUALITY PLAN
D2	ELECTRICAL SYSTEMS
D3	CONTROL & INSTRUMENTATION SYSTEMS



TITLE : TECHNICAL SPECIFICATION
FOR
SELF CLEANING STRAINERS (SCS)

SPEC. NO. PE-TS-412-165-N003

VOLUME : II B

SECTION : A

REV. NO. 0

DATE : 16.06.15

SHEET 1 of 1

SECTION - A
SCOPE OF ENQUIRY



TITLE : TECHNICAL SPECIFICATION
FOR
SELF CLEANING STRAINERS (SCS)

SPEC. NO. PE-TS-412-165-N003

VOLUME : II B

SECTION : A

REV. NO. 0

DATE :16.06.15

SHEET 1 of 2

1.00.0 SCOPE

This enquiry covers the design, manufacture, assembly, inspection and testing at manufacturer's and/or his sub-contractors works properly packed for delivery of the items as follows:

1.01.0 Self Cleaning Strainers :

Self Cleaning Strainers (SCS) complete with all accessories as per the requirements specified in different sections of this specification for 2X660 MW ENNORE SEZ STPP.

The bidder's scope also includes installation checks, commissioning, trial runs & PG Testing at site of SCS.

1.01.1 The bids shall be evaluated as per NIT.

2.00.00 GENERAL TECHNICAL INSTRUCTIONS:

2.01.00 It is not the intent to specify herein all the details of design and manufacture. However the equipment shall conform in all respects to high standard of design, engineering and workmanship, and shall be capable of performing the required duties in a manner acceptable to Engineer/ Owner, who will interpret the meaning of drawing and specifications, and shall be entitled to reject any component or material, which in his judgement is not in full accordance herewith.

2.0.2.00 The omission of specific reference to any component/ accessory necessary for the proper performance of the equipments shall not relieve the bidder of the responsibility of providing such facilities to complete the supply of the equipments at quoted prices.

2.03.00 In case of any deviation from this Technical specification (Vol. IIB) and General Technical Conditions (Vol. IIC), the same shall be indicated in the schedule of deviations enclosed in Volume-III, Part-A. In the absence of duly filled schedules it will be assumed that the bid strictly conforms to the specification.

2.04.00 BHEL's/ Customer's representatives shall be given full access to the shop in which the equipments are being manufactured or tested and all test records shall be made available to him.

2.05.00 The equipments covered under this specification shall not be despatched unless the same have been finally inspected, accepted and shipping release issued by BHEL/ Customer

2.06.00 Un-priced copy of price bid shall be furnished alongwith the technical bid.

2.07.00 **SCSs have been indicated with two alternative as indicated in data sheet-A of section-D of Volume-IIB. Bidder to quote for both the alternatives, however one of the Alternative shall be selected by BHEL and the same shall be informed during technical evaluation of bids.**



TITLE : TECHNICAL SPECIFICATION
FOR
SELF CLEANING STRAINERS
(SCS)

SPEC. NO. PE-TS- 412-165-N003

VOLUME : II B

SECTION : C

REV. NO. 0

DATE : 16.06.15

SHEET 1 of 1

SECTION - B

PROJECT INFORMATION

**SPECIFICATION
FOR
EPC CUM DEBT FINANCING CONTRACT
VOLUME II – GENERAL & SCHEDULES**

CHAPTER 1

PROJECT SYNOPSIS

1.0 GENERAL BACKGROUND AND SALIENT FEATURES

1.1 Introduction

Tamilnadu Generation and Distribution Corporation owns the proposed green-field 1320 MW (2 units of 660 MW each) Coal Based Thermal Power Station at Katupalli. This is an expansion of North Chennai Thermal Power Station (NCTPS) and located on some portion of the ashdyke of NCTPS.

1.2 Location

The proposed site for main power plant is located near Ennore port (approx 5 kms).

The nearest Railway station is at Athipattu Pudunagar (approx 5 kms)

All weather road from Pattamandri on the Thiruvottiyur-Ponneri district highway is the nearest road access.

The nearest airport is at Chennai at a distance of 60 km.

1.3 Type of Plant

The proposed 2x660 MW Super-Critical Power Project consists of coal fired steam generator connected to a reheat type steam turbine generator along with all the required auxiliaries. Circulating cooling water system is envisaged for condenser cooling.

The description and salient technical data of the Steam Generator, Steam Turbine Generator, Auxiliary systems, Electrical, Control & Instrumentation, Civil etc. are explained elsewhere in the specification:

1.4 PROJECT INFORMATION

Project Title : **2 x 660 MW Ennore SEZ Coal Based Supercritical Thermal Power Project at Ash Dyke of NCTPS**



2 x 660 MW Ennore SEZ Supercritical Thermal Power
Project at Ash Dyke of NCTPS
Spec. No. CE/C/P&E/EE/E/OT.No.03 /2013-14

Vol. II: 1



Owner : **TAMIL NADU GENERATION AND DISTRIBUTION CORPORATION (TANGEDCO)**

LOCATION

The site is located near Vayalur Village, Ennore

Latitude : 13⁰17' N to 13⁰18' N

Longitude : 80⁰18' E to 80⁰19' E

Distance from Chennai City : 35 km

Nearest Airport is at Chennai at a

Distance of : 60 km

Nearest Seaport is : Ennore

Nearest Railway Station is : Athipattu Pudunagar (approx 5 kms)

Meteorological Condition

Climate : Tropical ,very dry and hot summer, dry and cold winter and good rain-fall in monsoon accompanied with strong wind.

Climatological data : Ambient temp. (°C)
Annual Maximum Mean Temp 41.5(°C)
Annual Minimum Mean Temp 24(°C)
Design Ambient temperature 35(°C)

Relative Humidity

Maximum 100%

Minimum 36%

Design 75%

Annual Rainfall

Maximum 2540 mm

Average 1600 mm

Minimum 1175 mm

Prevailing Wind Direction

Nov to Jan – From NW & NE



2 x 660 MW Ennore SEZ Supercritical Thermal Power
Project at Ash Dyke of NCTPS
Spec. No. CE/C/P&E/EE/E/OT.No.03 /2013-14



Feb to Mar – From East & SE
 Apr to May – From South & SE
 June – From SW
 July to Aug – From NW
 Sept to Oct – From SE & SW
 Wind Speed 11.8 kmph (avg)
 50 kmph (max)
 Seismic Zone III as per
 IS:1893-2002

1.5 Access to Site

Site is well connected to all weather road from Pattamandri on the Thiruvottiyur – Ponneri district highway. Site is located adjacent to the Chennai – Howrah broad gauge line and thus well connected by rail also.

1.6 Plant Rating, Capacity, Availability, PLF

Each of the two units shall have a Turbine maximum continuous rating (TMCR) of 660 MW at generator terminals based on the following site conditions.

- Ambient air temperature
- Condenser cooling water inlet temperature of 33°C and 9°C temperature rise across the condenser.
- Generator power factor of 0.85.
- Fuel specification as given elsewhere.
- Design temperature for electrical equipment is 50°C.

The VVO capacity of the steam turbine shall not be less than 105% of TMCR flow at rated parameters. Boiler maximum Continuous Rating (BMCR) will be established to match the steam flow at VVO conditions, but BMCR flow shall not less than 108% of TMCR flow.

The capacity of the unit is selected so as to deliver the rated output even after ageing that will occur between overhauls, as a result of deposition of salts in turbine blades, wear and tear etc.

The plant load factor (PLF) being considered is 85%.

1.7 Power Evacuation

Power will be evacuated from the proposed thermal power station at 400 KV voltage level through 400 KV transmission lines . The power evacuation lines would be double circuit 400 KV lines which will act as Line in & Line out circuit.



2 x 660 MW Ennore SEZ Supercritical Thermal Power
 Project at Ash Dyke of NCTPS
 Spec. No. CE/C/P&E/EE/E/OT.No.03 /2013-14



1.8 Site Selection

The following factors which influence the project site selection have been found very favourable to establish and operate the project.

- a. Availability of fuel.
- b. Existing power plant
- c. Availability of adequate cooling water.
- d. Availability of adequate land for locating the power plant with approach roads.
- e. Suitability of land from topographical and geological aspects
- f. Proximity of National Highways, Ports & Transport of fuel & heavy equipment.
- g. Facility for interconnection with transmission and distribution system for evacuation of power.
- h. Environmental aspects.

Total land required for the project is 500 acres which is under the possession of TANGEDCO.

1.9 Fuel

1.9.1 Source of Fuel

Domestic coal requirement for the power plant will be sourced from Kalinga block of Talcher coal fields, Mahanadi and IB valley coal fields in the state of Orissa. Coal will be transported by sea. The port of dispatch and port of receipt for domestic coal would be Paradip port and Ennore port respectively. Imported coal shall be sourced from foreign countries through sea to Ennore port.

Coal can be transported from coal mines to Ennore port by sea and unloaded at proposed coal berth-III. Further the coal can be transported to the proposed power plant through pipe conveyor which shall have a system capacity of 2 x 2000TPH.

The steam generator shall be designed for the following conditions :

- **Best Coal** – 100% Imported Coal
- **Design Coal** – 70% Imported & 30% Domestic Coal
- **Worst Coal** – 50% Imported & 50% Domestic Coal

The analysis of fuel is given below :

1.9.2 Coal Analysis:

Coal Quality Parameters

SL.NO	DESCRIPTION	DOMESTIC COAL	IMPORTED COAL
1.	HIGHER HEATING	2800 (GCV as	6250 (GCV Air



2 x 660 MW Ennore SEZ Supercritical Thermal Power
Project at Ash Dyke of NCTPS
Spec. No. CE/C/P&E/EE/E/OT.No.03 /2013-14



	VALUE -As Fired basis given Kcal/kg	received basis)	dried basis) 5642 (as received basis)
2.	TOTAL MOISTURE %	During rainy season 20% (inherent + surface)	16.5%
3.	HGI Abrasive ness expected YGP Shale and sand stone content Feed coal size	45 to 55 Average 52 50 to 70 mg/kg 20% max. upto 50 mm.	51

DOMESTIC COAL

Sr. No.	Particulars	Units	Parameters
A.	Proximate Analysis		
1.	Moisture	%	16.00
2.	Volatile Matter	%	19.00
3.	Ash	%	45.00
4.	Fixed carbon	%	20.00
	Total	%	100
B.	ULTIMATE ANALYSIS, % (As received)		
1.	Carbon	%	27.70
2.	Hydrogen	%	2.60
3.	Nitrogen	%	0.52
4.	Oxygen	%	7.26
5.	Sulphur	%	0.50
6.	Ash	%	45.00
7.	Moisture	%	16.00
8.	Carbonates	%	0.38
9.	Phosphorous	%	0.04
10.	Others	%	-
	Total	%	100.00
C.	Ash fusion temperature	deg C	
1.	Initial deformation, IT	deg C	1100
2.	Spherical, ST	deg C	1200
3.	Hemispherical, HT	deg C	1300
4.	Fluid, FT	deg C	-
D.	Ash Analysis, %		
1.	SiO ₂	%	59.54
2.	Al ₂ O ₃	%	29.00
3.	Fe ₂ O ₃	%	6.42
4.	CaO	%	1.50
5.	Na ₂ O	%	0.08



2 x 660 MW Ennore SEZ Supercritical Thermal Power
Project at Ash Dyke of NCTPS
Spec. No. CE/C/P&E/EE/E/OT.No.03 /2013-14



Sr. No.	Particulars	Units	Parameters
6.	K ₂ O	%	-
7.	TiO ₂	%	1.60
8.	SO ₃	%	0.25
9.	P ₂ O ₅	%	0.51
10.	MgO	%	0.50
11.	Others	%	0.60
12.	Total		100.00
E	Resistivity of fly ash	Ohm - cm	1.73x 10 ¹²

IMPORTED COAL

Sr. No.	Particulars	Units	Parameters
A.	Proximate Analysis (As received)		
1.	Moisture	%	16.50
2.	Volatile Matter	%	36.45
3.	Ash	%	6.62
4.	Fixed carbon	%	40.43
5.	Total	%	100.00
B.	ULTIMATE ANALYSIS, % (As received)		
1.	Carbon	%	60.12
2.	Hydrogen	%	4.38
3.	Nitrogen	%	1.48
4.	Oxygen	%	10.37
5.	Sulphur	%	0.53
6.	Ash	%	6.62
7.	Moisture	%	16.5
8.	Carbonates	%	-
9.	Phosphorous	%	-
10.	Others	%	-
	Total	%	100.00
C.	Ash fusion temperature	deg C	
1.	Initial deformation, IT	deg C	1230
2.	Spherical, ST	deg C	1270
3.	Hemispherical, HT	deg C	1320
4.	Fluid, FT	deg C	-
D.	Ash Analysis, %		
1.	SiO ₂	%	36.00
2.	Al ₂ O ₃	%	13.90
3.	Fe ₂ O ₃	%	14.80
4.	CaO	%	12.70
5.	Na ₂ O	%	0.70
6.	K ₂ O	%	1.70
7.	TiO ₂	%	0.80



2 x 660 MW Ennore SEZ Supercritical Thermal Power
Project at Ash Dyke of NCTPS
Spec. No. CE/C/P&E/EE/E/OT.No.03 /2013-14



Sr. No.	Particulars	Units	Parameters
8.	SO ₃	%	10.60
9.	P ₂ O ₅	%	0.20
10.	MgO	%	8.60
11.	Others	%	-
12.	Total	%	100.00

The plant should be suitable to accept imported coal sourced from any country. The limiting parameters of imported coal are furnished below :

S. No.	Particulars	Unit	Parameter
1	Total Moisture (ARB)	%	Up to 23 (Max)
2	Ash (ADB)	%	Up to 20 (Max)
3	Gross Calorific Value (ADB)	Kcal / Kg	5800 - 6500
4	Sulphur (ADB)	%	Up to 1 (Max)
5	Fixed Carbon (ADB)	%	30-50
6	Volatile Matter (ADB)	%	25-45
7	HGI		45-60
8	IDT (Under Reducing Atmosphere)	Deg C	1100-1250
9	Size	mm	< 50

Note: ADB stands for “As dried Basis” and ARB for “As Received Basis”

1.9.3 Specification of LDO

Specific gravity @ 15° C	0.8348
Gross calorific value, Kcal/kg	10400
Pour point “°C” max.	12
Flash point “°C” min.	66
Sulphur % “T” max.	0.5
K. Viscosity in Centistokes @ 50° C max.	7.5
Ash by wt. %	0.01
Water & sediment Vol. Max. %	0.25

1.9.4 Specification of HFO

Flash point “°C” min.	66
K. Viscosity in Centistokes @ 50° C max.	370



2 x 660 MW Ennore SEZ Supercritical Thermal Power
Project at Ash Dyke of NCTPS
Spec. No. CE/C/P&E/EE/E/OT.No.03 /2013-14



Ash by wt. %	0.1
Water content by volume % max	1
Sediment by weight % max	0.25
Total Sulphur by weight % max	4.5
Gross calorific value, Kcal/kg	10800

1.9.5 Fuel Linkage

TANGEDCO has approached Ministry of Coal through Ministry of Power for the long term linkage of Coal from the coal sources of Talcher or Mahanadi in Orissa.

The coal requirement has been worked as under:-

Coal required at MCR per hr. (Blended) 872 tonnes

Per day 20928 tonnes.

Annual 6.5 MTPA for 85% PLF

1.9.6 Fuel Transportation

The coal shall be received at Ennore port. The coal will be transported by pipe conveyor from coal berth 3 in Ennore Port and then through 2 x 2000 TPH pipe conveyor to the bunker directly or to stockyard.

1.10 Source Of Water

1.10.1 Source

The raw water intake shall be from the existing cooling water forebay of NCTPS PHASE-II.

1.10.2 Chemical analysis of Sea Water:

As given in Annexure-1, Volume III, Chapter- 3.

1.10.3 Requirement

The requirement of water for the plant will be for meeting the requirement of make up for the re-circulating cooling water system, dust suppression system in coal handling plants, ash disposal system and the RO/ D.M. water plant which will be supplying the power cycle make up requirements, etc. In addition the water requirements will be for drinking and service purposes. Water requirement is estimated as approx. 15523 m³/hr.



1.11 Source of Equipment

The proposed plant will be supplied, erected and commissioned on Single EPC basis.

1.12 Power Evacuation Plan

Power will be evacuated from the proposed thermal power station at 400 KV voltage level through 400 KV transmission lines . The power evacuation lines would be double circuit 400 KV lines.

1.13 400 KV GIS Switchyard

The 400 KV Switchyard is proposed to have one and a half bus arrangement and will comprise following bays/circuits :

- ◆ 2 – Generator transformer bays
- ◆ 1– Start up transformer bay
- ◆ 4 – Line Bays
- ◆ 2 – Bus VT's
- ◆ 2 – Bus Reactor Bays
- ◆ 2 – Spare bay (Equipped)
- ◆ 1 – Equipped bay for future GT
- ◆ 2 – Equipped bays for future lines

The switchyard will be complete with galvanized steel structures, lightning surge arrestors, OPGW Equipment, CTs, PTs of suitable VA burden and accuracy class as required for measurement protection and communication, insulators, bus-bars clamps & hard wares etc. The switchyard will be controlled by computerized control and data acquisition (SCADA) system.

1.14 Average Yearly Generation

The average yearly generation is calculated considering the following.

- The expected plant load factor is 85 %. With this PLF the average yearly generation will be around 11914 Million units.

1.15 INFORMATION FOR ENVIRONMENTAL APPRAISAL**1.0 GENERAL INFORMATION ABOUT THE PROJECT**

- 1.1 Name / Title of the Project : 2 x 660 MW Ennore SEZ Coal Based Supercritical Thermal Power Project at Ash Dyke of NCTPS
- 1.2 Name of Owner : Tamilnadu Generation and Distribution Corporation (TANGEDCO)



2 x 660 MW Ennore SEZ Supercritical Thermal Power
Project at Ash Dyke of NCTPS
Spec. No. CE/C/P&E/EE/E/OT.No.03 /2013-14



- 1.3 Location of the Project : Near Vayalur Village, Ennore, Tamil Nadu
- 1.4 Site where proposed plant is to be located : Ash dyke of NCTPS
- 1.5 Capacity of the project under consideration : 2x 660MW
- 1.5.1 Govt. land / Private land / others : TANGEDCO land
- 1.5.2 Topographical feature, demographic profile & physiography : Site has differential levels and require filling to maintain the desired grade level of +10.00 meter above MSL
- 1.5.3 Nature of soil : Clayey soil
- 1.5.4 Distance from the nearest town / city / major human settlements : Chennai -35 km
- 1.5.5 Population to be displaced : Nil
- 1.5.6 Distance from water source : Approx. 5 km (from Cooling Water Forebay of NCTPS Stage II)
- 1.5.7 Area of forest land, if involved : Nil
- 1.5.8 Distance of forest from the site : N.A
- 1.6 Is this an extension? If so indicate capacity of existing plant : No
- 1.7 What is the ultimate capacity envisaged : 2x660 MW
- 2.0 GENERAL ENVIRONMENTAL INFORMATION**
- 2.1 Area of the land proposed to be acquired : Refer Plot Plan Land already acquired
- i. Area required for plant : 500 Acres
- ii. Ash disposal : 100 % dry fly ash disposal and



- 100% wet bottom ash disposal is envisaged to existing ash pond.
- iii. Plant facilities : The area is adequate for locating all the required systems for 2x660 MW.
- 2.2 Area proposed to be built-up or developed : Power station will be built-up in the proposed site as indicated in the plot plan.
- 2.3 Specify site characteristics River basin/ estuarine / coastal / others : Site is close to Buckingham Canal
- 2.4 Is the site situated in the forest area? Give following details : No
- 2.4.1 Area : N.A
- 2.4.2 Type of forests : N.A
- 2.5 Is site situated near to the forests? Give the distance from the site. : N.A.
- 2.6 Give a description of the flora within 25 km of your plant site under the following heads :
- a. Crops :
b. Forest :
c. Grass land :
d. Endangered species :
e. Others (Specify) :
- } Refer details in the specification elsewhere.
- 2.6.2 Give details of the following features, if they exist, within a radius of 25 km of the proposed site? :
- i. Fisheries :
ii. Sanctuary / natural park biosphere reserve :
iii. Lakes / ponds / reservoir :
iv. Stream / river : Buckingham canal is close to the site
v. Estuary / sea : Bay of Bengal is 5 km from site



- vi. Hills / mountains :
 - vii. Historic / cultural /
tourist /
archaeological scenic
sites / defence
installations
- 2.7 Human settlement :
- 2.7.1 Total number of persons :
proposed to be employed
- i. During construction : 2500

450(0.75person/MW) TANGEDCO
 - ii. During operation : direct employees



SEA WATER ANALYSIS

S.No.	Parameter	Unit	Value (Range)
1	General		
a	pH		7.94-8
b	Conductivity	millisiemens/cm	43.8-44.1
c	Temperature	Deg C	25-32
d	Turbidity	NTU	20-40
e	Total Organic carbon (total/ dissolved)	PPM of C	2.4-2.84
f	CO ₂	Mg/l	<2
g	TDS	Mg/l	39600-39740
h	BOD	Mg/l	10-12
i	COD	Mg/l	88-96
j	Oil & Grease	Mg/l	<10
k	Phenols	Mg/l	0.08-0.09
l	Free Residual Chlorine	Mg/l	<0.2
2	Cations		
a	Calcium	Mg/l	459-478
b	Magnesium	Mg/l	1510-1516
c	Sodium	Mg/l	10100-12000
d	Potassium	Mg/l	358-450
e	Ammonia	Mg/l	4.43-5.42
f	Strontium	Mg/l	12.9-12.4
g	Barium	Mg/l	1.55-1.58
h	Aluminum Total	Mg/l	1-1.8
i	Aluminum Dissolved	Mg/l	0.8-1.0
j	Manganese Total	Micro g/l	0.2-0.6
k	Manganese Dissolved	Micro g/l	0.1-0.2
l	Iron total	Micro g/l	220-260
m	Iron Dissolved	Micro g/l	Below detectable limit (detectable Limit : 10)
3	Anions		
a	Chloride	Mg/l	18994-19194
b	Sulphate	Mg/l	3710-3949
c	Nitrate	Mg/l	136-152
d	Nitrite	Mg/l	0.46-0.62
e	Bicarbonate	Mg/l	144-148
f	Carbonate	Mg/l	Nil
g	Fluoride	Mg/l	2.64-2.8
h	Boron	Mg/l	0.14-0.17
i	Phosphate	Micro g/l	240-380
j	Sulphide	Micro g/l	Below detectable limit (detectable Limit : 100)
k	Silica Dissolved	Micro g/l as SiO ₂	200-250
4	Heavy Metals		
A	Arsenic	Micro g/l	Below detectable limit (detectable Limit : 2)
B	Mercury	Micro g/l	Below detectable limit (detectable Limit : 1)
C	Cadmium	Micro g/l	120-130
D	Copper	Micro g/l	200-220
E	Nickel	Micro g/l	470-490
F	Molybdenum	Micro g/l	Below detectable limit (detectable Limit : 100)



5	Suspended Particle Size Range		
A	10 micron & above	Mg/l	Below detectable limit (detectable Limit : 10)
B	5 micron to 10 micron	Mg/l	Below detectable limit (detectable Limit : 10)
C	1 micron to 5 micron	Mg/l	Below detectable limit (detectable Limit : 10)
D	0.1 micron to 1 micron	Mg/l	20-26
6	Colloidal Particle Size Range		
A	SDI (10 Minutes)	-	10-20
B	SDI (5 Minutes)	-	20-40
7	Density of sea water	Kg/ cum	1030

Note : Unless otherwise indicated all elements shall be expressed in respective ionic form only.





TITLE : TECHNICAL SPECIFICATION
FOR
SELF CLEANING STRAINERS
(SCS)

SPEC. NO. PE-TS- 412-165-N003

VOLUME : II B

SECTION : C

REV. NO. 0

DATE : 16.06.15

SHEET 1 of 1

SECTION – C

SPECIFIC REQUIREMENTS

- SECTION C1 : SELF CLEANING STRAINERS (MECHANICAL)
SECTION C2 : ELECTRICAL SYSTEMS
SECTION C3 : C&I SYSTEMS



TITLE : TECHNICAL SPECIFICATION
FOR
SELF CLEANING STRAINERS

SPEC. NO. PE-TS- 412-165-N003

VOLUME : IIB

SECTION : C

REV. NO. 0

DATE :
16.06.15

SHEET 1 of 1

SECTION C1
SELF CLEANING STRAINERS
(MECHANICAL DETAILS)



TITLE : TECHNICAL SPECIFICATION
FOR
SELF CLEANING STRAINERS(SCS).

SPEC. NO: PE-TS-412-165-N003

VOLUME : II B

SECTION:C1

REV. NO. 0

DATE :16.06.2015

SHEET 1 OF 8

1.0 GENERAL

The Self Cleaning Strainers (SCS) complete with all accessories shall conform to the standard technical specifications (Section-D) and Data Sheet-A enclosed herewith. In addition the requirements of this section C shall also be complied with. However, wherever the details given in Section-D and Data Sheet-A are different, the requirements of Data Sheet-A shall prevail. Similarly in the event of contradictions between Section-C & Section-D/ Data Sheet-A, Section-C shall prevail.

Section C consists of 3 parts viz. Sec. C1, C2 and C3 for Mechanical, Electrical and C&I respectively, the requirements of all 3 sections shall be complied with.

2.0 DESCRIPTION OF EQUIPMENTS :

2.1 Self Cleaning Strainers (SCS) :

Self Cleaning Strainers per unit where specified shall be installed on the discharge of the ACW pumps. The water through the self cleaning strainers outlet shall be supplied to the Secondary side of Plate Heat Exchangers. The water analysis is indicated in project information in section B.

3.0 SCOPE OF SUPPLY UNDER THE SPECIFICATION IN THE BIDDER'S SCOPE FOR SELF CLEANING STRAINERS.

3.1 The scope of supply for Self Cleaning Strainers covered under this specification is as under.

The size, MOC's and other particulars of the equipments are detailed in Data Sheet A annexed with Section – D of the specification.

SL.NO.	PROJECT	SELF CLEANING STRAINERS
1.	2X660 MW ENNORE SEZ STPP	2 SETS PER UNIT VIZ. TOTAL 4 SETS FOR 2 UNIT.



TITLE : TECHNICAL SPECIFICATION
FOR
SELF CLEANING STRAINERS(SCS).

SPEC. NO: PE-TS-412-165-N003

VOLUME : II B

SECTION:C1

REV. NO. 0

DATE :16.06.2015

SHEET 2 OF 8

3.2 SCOPE OF SUPPLY OF SCS INCLUDED IN THE BIDDER'S SCOPE :

The Qty of SCS covered under the specification shall be as per Data Sheet A.

Each self cleaning strainer shall be complete with following accessories and auxiliaries.

- a) Flushing pump with drive Motor (as per manufacturer's design) - 1 No.
- b) Complete Pipe work, including interconnection piping (as applicable) & debris disposal piping, flanges/counter flanges for pipes, bends, fittings, and piping support installation materials shall be in Purchaser's scope. However, valves along with its Flanges/Counter Flanges/Gaskets/Nuts & Bolts shall be in Bidder's Scope. Isometric Drawing along with BOM for interconnection piping, flanges/counter flanges for pipes, bends, fittings and piping support installation materials inline with approved Installation Drawing to be submitted by the Bidder within 4 weeks after approval of the Installation Plan. Minimum Pipe Size to be considered by the Bidder for all interconnecting piping shall be 200 Nb.
- c) Filter body/ housing Vent and Drain connections along with their isolating valves.
- d) SCS shall be supplied along with flanges as well as the Counter flanges, complete with bolts, nuts and gaskets.
- e) Differential pressure measuring system for SCS. DP measuring system shall comprise of 2 Nos. DPT + 1 No. DPG for SCS and shall be with *Remote seal* arrangement. Stubs for DPT and DPG shall be independent.
- f) Supporting arrangement complete with foundation plates, anchor bolts, nuts, sleeves, inserts, all installation materials, fixing bolts, clamps, saddle supports (if applicable) and other accessories etc for complete equipment supplied under this package.
- g) Set of commissioning spares, on "As required basis".
- h) The Electrical & C&I items/ accessories as specified in succeeding clause / respective sections herein.
- i) Starter Panel (switch gear panel) shall be as follows:

2 Sets of SCS shall have one Common Starter Panel (switch gear panel) for DCS based control system.

Switch Gear Panel should have suitable arrangement like Bus Coupler for providing redundancy to incoming supply feeder (1 working + 1 supply feeder).



TITLE : TECHNICAL SPECIFICATION
FOR
SELF CLEANING STRAINERS(SCS).

SPEC. NO: PE-TS-412-165-N003

VOLUME : II B

SECTION:C1

REV. NO. 0

DATE :16.06.2015

SHEET 3 OF 8

- j) Power and Control cables between Panel and various drives in bidder's scope of supply.
- k) Control cables between field instruments and panel.
- l) Control cables between field instruments and switchgear panel.
- m) Set of mandatory spares as indicated in Data Sheet A.
- n) All the field instruments stipulated in this specification shall be in Bidder's scope.
- o) Finish paints for touch up painting of equipment after erection at site, in sealed containers.
- p) Set of special tools and tackles if required for maintenance and erection of the equipment supplied.
- q) Various drawings, data test reports/ certificates instruction manuals for erection operation and maintenance etc. and cables schedule indicating BOQ for power & control cables.
- r) Local Control Panels & Instruments: Scope and Type as specified in C&I section wherever required.
- s) Cathodic Protection of SCS along with sacrificial Anode.

Any item not specified but required to make SCS a complete package shall also be in bidders scope.

4.0 SCOPE OF SERVICES INCLUDED IN THE BIDDER'S SCOPE :

The bidder's scope also includes following services at site, for scope under this specification for SCS for respective projects

- a) Installation checks (Erection in BHEL's scope).
- b) Commissioning of equipment.
- c) Trial run for requisite period
- d) Performance Testing

The trial run of equipment shall be generally conducted immediately after commissioning while PG testing shall be conducted at a later date. These activities for different units shall be timed separately.

The no. of visits may be suitably assessed by bidders as per their experience with



TITLE : TECHNICAL SPECIFICATION
FOR
SELF CLEANING STRAINERS(SCS).

SPEC. NO: PE-TS-412-165-N003

VOLUME : II B

SECTION:C1

REV. NO. 0

DATE :16.06.2015

SHEET 4 OF 8

site stay periods on as required basis.

In the event of order no. of visits as follows shall be made as a minimum with charges included in the bidder's base price itself.

• **For drawings/documents approval**

In the event of order all drawings / documents in soft as well as hard copy shall be submitted as per NIT.

Further on receipt of Customer comments, if required bidder's engineer shall visit BHEL/ Customer alongwith soft copy to resolve all issues and incorporate comments in the soft copy for across the table finalisation and Category-I approval.

• **Site Visits :**

- i. No. of site visits for combined activities of erection checks and commissioning for SCS as applicable shall be one per unit - for both sets of equipments of one unit. Time duration for erection and commissioning shall be "on as required basis" with equipments run for trial operation thereafter for requisite period to demonstrate satisfactory operation.

However the no. of visits may be suitably assessed by bidders as per their experience with site stay periods on as required basis.

- ii. Bidder shall demonstrate guarantees including pressure drops at site during subsequent visit for SCS of each unit.
- iii. For trouble shooting on "as required basis".

5.0 EXCLUSIONS :

The following are excluded from the bidder's scope .

- 5.1 Civil foundation works required for installation
- 5.2 Erection of Equipment at site.

6.0 DESIGN CONSTRUCTION :

In addition to the requirements of Section-D the following shall also be complied with for packages/ projects under scope of this specification:

- 6.1 The materials of construction specified in Data Sheet-A are minimum requirements and



TITLE : TECHNICAL SPECIFICATION
FOR
SELF CLEANING STRAINERS(SCS).

SPEC. NO: PE-TS-412-165-N003

VOLUME : II B

SECTION:C1

REV. NO. 0

DATE :16.06.2015

SHEET 5 OF 8

materials of construction for other components not specified shall be similarly selected by the bidder for the intended duty which shall be subject to purchaser's approval during detailed engineering in the event of order.

- 6.2 Housing/ body of SCS Filter shall be designed and manufactured as per the applicable codes for pressure vessels and to take care of force and moments as enclosed in the specification. However in no case thickness of housing/ body shall be less than the thickness as specified in "Pipe size Table" enclosed in Data Sheet-A of SCS.
- 6.3 Cathodic Protection for SCS along with Sacrificial Anode shall be provided by the bidder in the equipment.
- 6.4 Velocity in the pipe work shall be less than 1.5 m/ sec for pump suction and less than 2.4 m/ sec. in other pipe work. All valves upto 150 NB shall be ball valves. For higher sizes, gate/ globe/ B.F. valves shall be provided. All instrument valves shall be needle valves.

7.0 Self Cleaning Strainers :

- 7.1.1 Performance Guarantee Parameters shall be as under :
- Pressure drop in Self Cleaning Strainers in clean condition viz. after backwashing.
- 7.1.2 Bidder to note that bids shall be evaluated on account of pressure drop across Self Cleaning Strainers (in clean condition) & liquidated damages on account of not meeting the same shall be in accordance with following :

A) Bid Evaluation Criteria and Liquidated Damages:

The bids received shall be evaluated for Pressure drop across Self Cleaning strainers :

- The permissible limit of pressure drop across self cleaning strainers in clean condition shall be 0.6 MWC.
- If the pressure drops quoted are higher than above limit, the bids shall be technically loaded @ Rate as mentioned in Data Sheet-A on pro-rata basis per **0.1 MWC** pressure drop (viz. per unit).
- However no advantage shall be given for pressure drops quoted less than above permissible limit.
- The maximum acceptable limit for pressure drop across self cleaning strainer (with technical loadings) shall be 1.0 MWC.
The bids will be technically rejected for pressure drops quoted higher than above maximum limit.
- The guaranteed pressure drops shall be demonstrated at site by vendors and if found higher shall be subject to LD @ twice the bid evaluation



TITLE : TECHNICAL SPECIFICATION
FOR
SELF CLEANING STRAINERS(SCS).

SPEC. NO: PE-TS-412-165-N003

VOLUME : II B

SECTION:C1

REV. NO. 0

DATE :16.06.2015

SHEET 6 OF 8

factor as above.

8.0 SPARES :

8.1 Recommended Spares :

Bidder to submit the list of recommended spares (along with prices) as per NIT required for three (3) years of reliable operation and maintenance of SCS for BHEL reference purpose only.

The recommended spares shall not be considered for evaluation and ordering purpose.

8.2 Mandatory Spares : As per Datasheet-A.

9.0 Quality Plan

Bidder shall submit QP in the event of order based on the guidelines given in the specification & QP enclosed therein. QP will be subject to BHEL/ Customer approval and customer hold points for inspection/ testing shall be marked in the QP at the contract stage. Inspection/ testing shall be witnessed as per same apart from review of various test certificates/ Inspection records etc. Charges for 3rd party inspection (TUV/ equivalent) for imported components wherever required shall be included by bidder in the base price itself. Witness for all the test identified under agency "C" & "N" in Quality plan shall be by third party.

If BHEL or BHEL customer decides to witness the tests along with third party, the cost of travel of BHEL or BHEL customer shall be borne by BHEL or BHEL customer themselves.

10.0 DELIVERY & DRAWINGS/ DOCUMENTS DISTRIBUTION SCHEDULE :

a. Delivery of Equipment shall be as per NIT.

b. Drawings submission schedule shall be as per NIT/as advised by Project Group.

11.0 The makes of various bought out items shall be subjected to purchaser's approval in the event of order.

12.0 It is mandatory for the bidders to submit along with the bid the deviations if any whether major or minor in the schedule of deviations only. ***In the absence of deviations listed in the schedule of deviations the offer shall be deemed to be in full conformity with the specification "non-withstanding" any thing else stated elsewhere in bidder's offer, data sheets etc. The implied/ indirect deviations in data sheets etc. Shall not be binding on the purchaser.***



TITLE : TECHNICAL SPECIFICATION
FOR
SELF CLEANING STRAINERS(SCS).

SPEC. NO: PE-TS-412-165-N003

VOLUME : II B

SECTION:C1

REV. NO. 0

DATE :16.06.2015

SHEET 7 OF 8

13.0 The following documents shall be furnished by the bidder with his offer :

- Compliance certificate duly signed and stamped (Enclosed at Schedules).
- Guarantee schedule duly signed and stamped (Enclosed at Schedules).
- GA drawings of following with empty/ filled-ups.
 - GA of SCS (As applicable).
 - Debris Flushing pumps (if applicable)
 - Other equipments considered necessary for Layout/ Civil.
- Electrical Load Data (Enclosed at Vol. III of Specification)
- Schedule of Deviation (Enclosed at Schedules).

The bidder to note that load requirement furnished and finalised during tender stage shall only be provided by BHEL and any changes or additional requirement of Electrical load by bidder during contract stage shall be provided by BHEL with cost repercussions to the bidder.

NOTE: Apart from above, no other drawing/ document/ data sheet etc. shall be submitted along with the offer. If any drawing/ document etc. is submitted with the offer, same shall be considered as for 'Reference' purpose only and shall not be reviewed/ commented upon and any deviation, exclusion to scope, etc. taken in documents but not highlighted in the deviation schedule shall not be taken cognizance of.



TITLE : TECHNICAL SPECIFICATION
FOR
SELF CLEANING STRAINERS(SCS).

SPEC. NO: PE-TS-412-165-N003

VOLUME : II B

SECTION:C1

REV. NO. 0

DATE :16.06.2015

SHEET 8 OF 8

ANNEXURE-I

SELF CLEANING STRAINERS

OPTION- I :-

SL.NO.	Projects	Size (NB)	Length of SCS (Excluding Counter Flange)	Scope of Counter Flange	Scope of nuts and bolts.
1.	2X660 MW ENNORE SEZ TPP	800 NB	2500 mm	In Bidder's Scope	In Bidder's Scope

OPTION- II :-

SL.NO.	Projects	Size (NB)	Length of SCS (Excluding Counter Flange)	Scope of Counter Flange	Scope of nuts and bolts.
1.	2X660 MW ENNORE SEZ TPP	900 NB	2500 mm	In Bidder's Scope	In Bidder's Scope

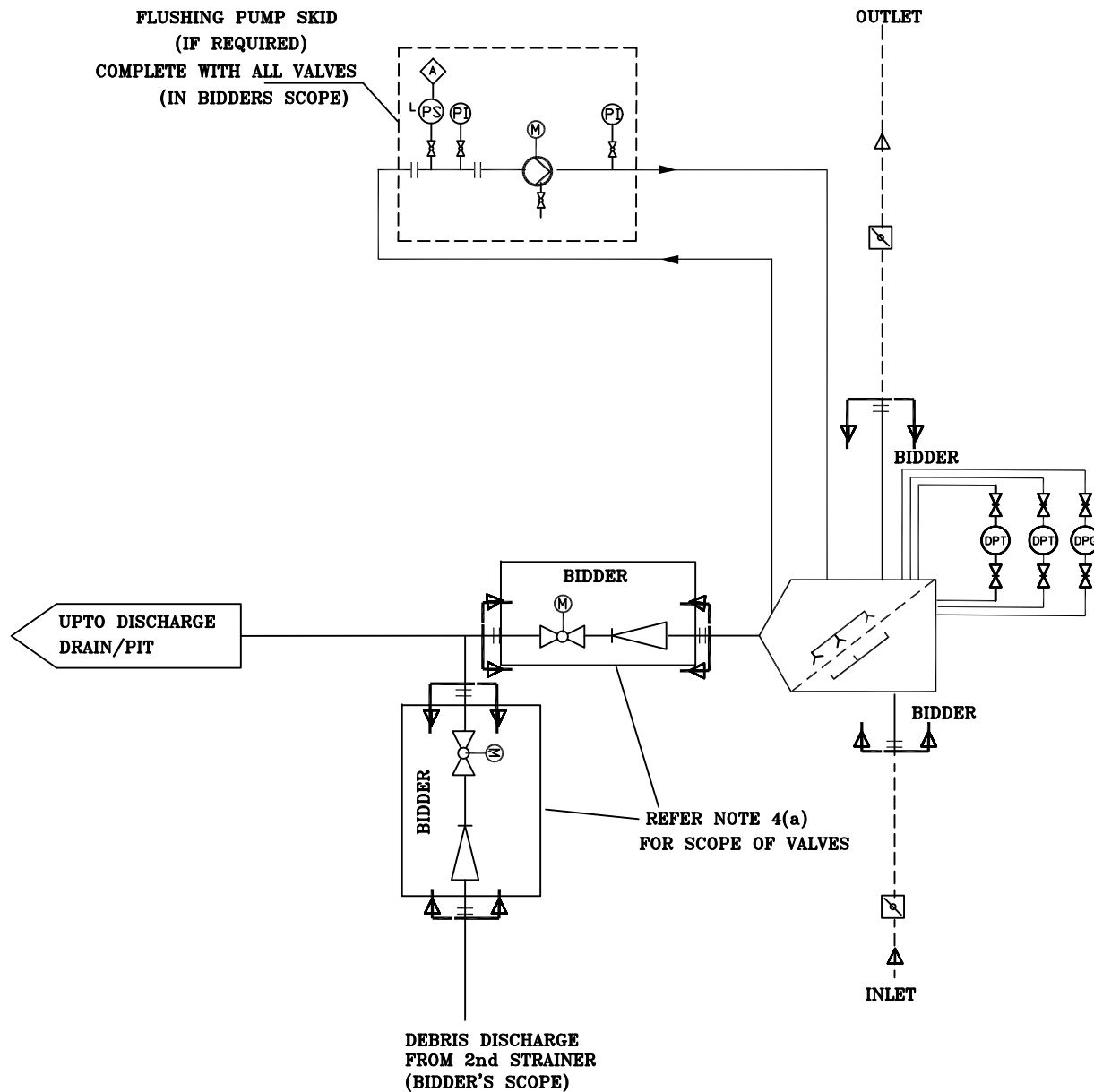

NOTE :-

1. SCHEMATIC SHOWN IS TYPICAL FOR ONE SCS, SHALL BE IDENTICAL FOR THE SECOND SCS.
2. INSTRUMENTS/ANNUNCIATIONS/ INTERLOCKS INDICATED IN THE SCHEME ARE TENTATIVE, SHALL BE PROVIDED AS PER APPROVED DRGS./ DOCUMENTS/ CONTROL PHILOSOPHY IN THE EVENT OF ORDER.
3. COUNTERFLANGES FOR SCS ARE INCLUDED IN BIDDERS SCOPE. ALL INTERCONNECTING / DEBRIS DISPOSAL PIPING IS INCLUDED IN PURCHASER SCOPE.
4. BIDDER'S SCOPE OF SUPPLY ALSO INCLUDES :
 - a) ALL VALVES & NRVs ON PURCHASER'S INTERCONNECTING /DEBRIS DISPOSAL PIPING ALONGWITH THEIR COUNTER FLANGES.
 - b) FLUSHING PUMP SKID, IF REQUIRED COMPLETE WITH FLUSHING PUMP, VALVES, INSTRUMENTS ETC.
5. PURCHASER BIDDER'S SCOPE OF SUPPLY

FLOW DIAGRAM FOR
SELF CLEANING STRAINER



TITLE : TECHNICAL SPECIFICATION
FOR
SELF CLEANING STRAINERS

SPEC. NO. PE-TS- 412-165-N003

VOLUME : IIB

SECTION : C

REV. NO. 0

DATE :
16.06.15

SHEET 1 of 1

SECTION C2
SELF CLEANING STRAINERS
(ELECTRICAL DETAILS)



**TECHNICAL SPECIFICATION FOR
SCS
(ELECTRICAL PORTION)**

SPECIFICATION NO. PE-TS-412-174-A001
VOLUME II B
SECTION-C
REV 01 DATE 22.05.2015
PAGE 1 OF 1

SPECIFIC TECHNICAL REQUIREMENTS: ELECTRICAL

1.0 EQUIPMENT & SERVICES TO BE PROVIDED BY BIDDER/ PURCHASER

- 1.1 Scope for supply, and erection & commissioning of various equipment forming part of electrical system for this package shall be as per Annexure-I to Section – C [Scope of Work (Electrical)].
- 1.2 Make of various equipment/ items in the scope of bidder shall be to approval of owner during detailed engineering stage without any commercial implications.
- 1.3 Bidder shall furnish all AC as well as DC loads required for the system at different voltage levels (eg. 415V AC, 240 V AC, 220 V DC etc.) of all types, such as motor feeders, supply feeders in PEM format along with the offer.
- 1.4 All electrical equipment shall be suitable for the power supplies, fault levels and climatic conditions indicated in project information enclosed with the specification.
- 1.5 All drawings, data sheets, Quality Plan, calculations, test reports, test certificates, etc. shall be submitted during detailed engineering stage as per formats enclosed. The same shall be subject to approval without any commercial implications.
- 2.0 **In case of any discrepancy between Customer specification and BHEL standard specification, Customer specification shall prevail.**

3.0 DOCUMENTS TO BE SUBMITTED ALONG WITH BID

- 3.1 Bidder shall confirm total compliance to the electrical specification without any deviation from the technical/ quality assurance requirements stipulated. In line with this, the bidder as technical offer shall furnish two signed and stamped copies of the following:
- A copy of this sheet “Electrical Equipment Specification for Ventilation System’ and sheet “Electrical Scope between BHEL and Vendor” with bidder’s signature and company stamp.
 - List of Erection and Commissioning spares.
 - List of Erection & Maintenance tools & tackles.
 - Electrical load requirement in the load data format.
- 3.2 No technical submittal such as copies of data sheets, drawings, write-up, quality plans, type test certificates, technical literature, etc, is required during tender stage. Any such submission even if made, shall not be considered as part of offer.

4.0 LIST OF ENCLOSURES

- Electrical scope between BHEL & vendor (Annexure-I).
- Electrical Section-C
- Technical specification – Customer specification - Motors
- BHEL standard specification for LT motors : PE-SS-999-506-E101 (Section-D)
- Datasheets – A and C
- Quality Plan for motors.
- Load data format (Annexure-II).
- Cable Schedule Format(Annexure-III)

STANDARD ELECTRICAL SCOPE BETWEEN BHEL AND VENDOR (FOR EPC PROJECTS)

PACKAGES: COLTCS/ SCF/ DF/ TBS
SCOPE OF VENDOR: SUPPLY

PROJECT: 2X660 MW ENNORE TPP

S.NO	DETAILS	SCOPE SUPPLY	SCOPE E&C	REMARKS
1	415V MCC Starter cum control panel (if applicable)	BHEL Vendor	BHEL BHEL	240 V AC (supply feeder)/415 V AC (3 PHASE 4 WIRE) supply shall be provided by BHEL based on load data provided by vendor at contract stage for all equipment supplied by vendor as part of contract. Any other voltage level (AC/DC) required will be derived by the vendor.
2	Local Push Button Station (for motors)	BHEL	BHEL	Located near the motor.
3	Power cables, control cables and screened control cables for a) both end equipment in BHEL's scope b) both end equipment in vendor's scope c) one end equipment in vendor's scope	BHEL Vendor BHEL	BHEL BHEL BHEL	1. For 3.b) & c): Sizes of cables required shall be informed by vendor at contract stage (based on inputs provided by BHEL) in the form of cable listing. Finalisation of cable sizes shall be done by BHEL. Vendor shall provide lugs & glands accordingly. 2. Cabling/ termination by BHEL.
4	Junction box for control & instrumentation cable	Vendor	BHEL	Number of Junction Boxes shall be sufficient and positioned in the field to minimize local cabling (max 10-12 mtrs) and trunk cable.
5	Any special type of cable like compensating, co-axial, prefab, MICC, fibre optical etc.	Vendor	BHEL	Refer scope/ C&I portion of specification for scope of fibre Optical cables if used between PLC/ micro processor & DCS.
6	Cable trays, accessories & cable trays supporting system	BHEL	BHEL	
7	Cable glands and lugs for equipment supplied by Vendor	Vendor	BHEL	1. Double compression Ni-Cr plated brass cable glands 2. Solder less crimping type heavy duty copper lugs for power & control cables.
8	Conduit and conduit accessories for cabling between equipment supplied by vendor	Vendor	BHEL	Conduits shall be medium duty, hot dip galvanised cold rolled mild steel rigid conduit as per IS: 9537.
9	Lighting	BHEL	BHEL	

STANDARD ELECTRICAL SCOPE BETWEEN BHEL AND VENDOR (FOR EPC PROJECTS)

PACKAGES: COLTCS/ SCF/ DF/ TBS

SCOPE OF VENDOR: SUPPLY

PROJECT: 2X660 MW ENNORE TPP

S.NO	DETAILS	SCOPE SUPPLY	SCOPE E&C	REMARKS
10	Equipment grounding & lightning protection	BHEL	BHEL	
11	Below grade grounding	BHEL	BHEL	
12	LT Motors with base plate and foundation hardware	Vendor	BHEL	Makes shall be subject to customer/ BHEL approval at contract stage.
13	Mandatory spares	Vendor	-	Vendor to quote as per specification.
14	Recommended O & M spares	Vendor	-	As specified elsewhere in specification
15	Any other equipment/ material/ service required for completeness of system based on system offered by the vendor (to ensure trouble free and efficient operation of the system).	Vendor	BHEL	
16	a) Input cable schedules (Control & Screened Control Cables) b) Cable interconnection details for above c) Cable block diagram	Vendor Vendor Vendor	- - -	Cable listing for Control and Instrumentation Cable in enclosed excel format shall be submitted by vendor during detailed engineering stage.
17	Equipment layout drawings	Vendor	-	For preparation of cabling layout drawings by BHEL, vendor shall furnish Electrical equipment layout drawings (both in print form as well as in AUTOCAD) of the complete plant (including electrical area) indicating location and identification of all equipment requiring cabling,
18	Electrical Equipment GA drawing	Vendor	-	For necessary interface review.

NOTES:

1. Make of all electrical equipment/ items supplied shall be reputed make & shall be subject to approval of BHEL/customer after award of contract.
2. All QPs shall be subject to approval of BHEL/customer after award of contract without any commercial implication.
3. In case the requirement of Junction Box arises on account of Power Cable size mis-match due to vendor engineering at later stage, vendor shall supply the Junction Box for suitable termination.

2X660MW ENNORE TPP

MOTOR DATA SHEET-A

SPECIFIC ELECTRICAL REQUIREMENT FOR SCS SYSTEM

SL.NO.	PARAMETERS	UNIT	Ennore
	MOTOR		
1	DESIGN AMBIENT TEMP	DEG. C	50
2	VOLTAGE SUPPLY AND VARIATION	VOLT	415V, \pm 10%
3	FREQUENCY WITH VARIATION	Hz	50, +3% to -5%
4	COMBINED VOLTAGE & FREQUENCY VARIATION		10%
5	MAX ACCEPTABLE RATING OF MOTOR AT 415 V	KW	160 KW & below
6	SYSTEM FAULT LEVEL AND ITS DUARTION	KA	50kA, 1sec
7	SUTABILITY OF TERMINAL BOX FOR FAULT LEVEL AND DURATION		50 KA, 0.25 sec
8	CLASS OF INSULATION & TEMP RISE LIMITED TO		Class-F and temp rise limited to Class-B
9	MIN. STARTING VOLTAGE		85%
10	MOTOR RATING FOR SINGLE PHASE SUPPLY		0.2 kW & Below
11	MAXIMUM LOCKED ROTOR CURRENT	% OF FLC	600% inclusive of IS tolerance.
12	ACCEPTABLE NOISE LEVEL	DB	As per IS 12065
13	TYPE OF STARTER PROVIDED IN MCC		DOL
14	DOP OF ENCLOSURE		IP-55 & IP-54 for outdoor & indoor resp.
15	SPACE HEATER REQUIREMENT	<30kW	30KW & ABOVE
16	PAINT SHADE		Siemens Grey (RAL 7032)
17	SPECIAL REQUIREMENT		-
18	ENERGY EFFICIENT		All LV MOTORS ABOVE 10 KW WITH S1 DUTY SHALL BE COMPULSORILY OF ENERGY EFFICIENT LEVEL IE2 AS PER IS 12615:2011

CHAPTER – 12

MOTORS

1.00.00 DESIGN CRITERIA

1.00.01 For the purpose of design of equipments /systems, an ambient temperature of 50 °C and relative humidity of 85% shall be considered. The equipment shall operate in a highly polluted environment.

1.00.02 Transient voltage dip on starting of the largest motor with DOL shall be limited to 20% of the nominal system voltage at the voltage terminals.

1.00.03 Rating

The motor rating shall be arrived at considering 15% margin over the duty point input or 10% over the maximum demand of the driven equipment, whichever is higher, considering highest system frequency.

All motors shall be continuously rated (S1 duty). However, crane motors shall be rated for S4 duty, 40% cyclic duration factor.

Whenever the basis for motor ratings are not specified in the corresponding mechanical specification sub-sections, maximum continuous motor ratings shall be at least 10% above the maximum load demand of the driven equipment under entire operating range including voltage and frequency variations.

1.00.04 Starting Voltage requirement for all motors (except mill motors):

1. 85 % of rated voltage for motors up to 1000 kW
2. 80 % of rated voltage for above 1000 kW and up to 4000 kW
3. 75 % of rated voltage for above 4000 kW

For Mill Motors:

1. 85 % of rated voltage for motors above 1000 kW
2. 90 % of rated voltage for motors up to 1000 kW

1.00.05 Canopy shall be provided for outdoor motors.

1.01.00 Contractor shall provide fully compatible electrical system, equipments, accessories and services.



1.02.00 All the equipment, material and systems shall, in general, conform to the latest edition of relevant National and international Codes & Standards, especially the Indian Statutory Regulations.

1.03.00 Voltage and frequency variations:

Frequency: (+) 3% and (-) 5%

Voltage : **i. AC**

a. $\pm 6\%$ for 11 kV/3.3 kV

b. $\pm 10\%$ for 415 V

Combined 10 % (absolute sum)

ii. DC- +10% to -15% for 220 V DC

1.04.00 All LV motors above 10 kW with S1 duty shall be compulsorily of Energy efficient level IE 2 as per IS 12615: 2011.

1.05.00 The responsibility of coordination with electrical agencies and obtaining all necessary clearances shall be of the contractor.

1.06.00 Type

AC Motors:

(a.) Squirrel cage induction motor suitable for direct-on-line starting.

(b.) Crane duty motors shall be slip ring type induction motor

DC Motors

(a.) Shunt wound.

1.07.00 Temperature Rise

Air cooled motors

70°C by resistance method

Water cooled

80° C over inlet cooling water temperature mentioned elsewhere, by resistance method.

1.08.00 Degree of Protection

Degree of protection for various enclosures shall be as follows :

i) Indoor motors – IP 54



- | | | | |
|------|--|---|-------|
| ii) | Outdoor motors | – | IP 55 |
| iii) | CW motors (in case of screen prot. Drip proof) | – | IP 23 |
| iv) | Cable box – indoor area | – | IP 54 |
| v) | Cable box – outdoor area | – | IP 55 |

2.00.00 CODES AND STANDARDS

2.01.00 All motors shall confirm to the latest editions including all applicable amendment of relevant IS, IEC and CBIP standards/Publications. In case any other standard is followed that ensures equal or better quality, may be accepted. However the English version of the Standard adopted shall be submitted.

2.02.00 Major Standards, which shall be followed, are listed below. Any other applicable Indian standards for any component part even if not covered in the list shall also be followed

- | | | | |
|-----|---|---|--|
| 1.) | Three phase induction motors | : | IS:325, IEC:60034 |
| 2.) | Single phase AC motors | : | IS:996, IEC:60034 |
| 3.) | Crane duty motors | : | IS:3177, IEC:60034 |
| 4.) | DC motors/generators | : | IS:4722 |
| 5.) | Degree of protection by enclosures for rotating electrical machines | : | IS: 4691
IS: 4728
IS: 6362
IS: 2253 |
| 6.) | Noise levels for rotating electrical machines | : | IS: 12065 |
| | Mechanical Vibrations for rotating electrical machines | : | IS: 12075 |

3.00.00 OPERATIONAL REQUIREMENTS

3.01.00 Starting Time

3.01.01 For motors with starting time up to 20 secs at minimum permissible voltage during starting, the locked rotor withstand time under hot condition at highest voltage limit shall be at least 2.5 secs more than starting time .

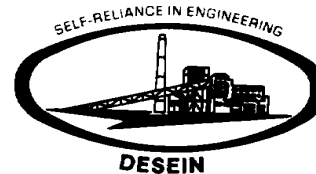

- 3.01.02 For motors with starting time more than 20 secs and up to 45 secs at minimum permissible voltage during starting, the locked rotor withstand time under hot condition at highest voltage limit shall be at least 5 secs more than starting time.
- 3.01.03 For motors with starting time more than 45 secs at minimum permissible voltage during starting, the locked rotor withstand time under hot condition at highest voltage limit shall be more than starting time by at least 10% of the starting time.
- 3.01.04 Speed switches mounted on the motor shaft shall be provided in cases where above requirements are not met.
- 3.01.05 Motors shall be capable of restarting under full load after a momentary loss of voltage with the possibility of 150 % nominal voltage during fast bus transfer.
- 3.02.00 Torque Requirements
- 3.02.01 Accelerating torque at any speed with the lowest permissible starting voltage shall be at least 10% motor full load torque.
- 3.02.02 Pull out torque at rated voltage shall not be less than 205% of full load torque. It shall be 275% for crane duty motors.

4.00.00 DESIGN AND CONSTRUCTIONAL FEATURES

- 4.00.01 Suitable single phase space heaters shall be provided on motors rated 30 kW and above to maintain windings in dry condition when motor is standstill. Separate terminal box for space heaters & RTDs shall be provided.
- 4.00.02 All motors shall be suitable for direct on line starting through any type of breaker.
- L All motors shall be either totally enclosed fan cooled (TEFC) or totally enclosed tube ventilated (TETV) or Closed air circuit air cooled (CACA) type. However, motors rated 3000KW or above can be Closed air circuit water cooled (CACW). CW motors can be screen protected drip proof (SPDP) type. Motors located in hazardous areas shall have flame proof enclosures conforming to IS: 2148 as detailed below
- (a) Fuel oil area : Group - IIB
- (b) Hydrogen generation plant Group - IIC
area :
- 4.00.03 Winding and Insulation
- (a) Type : Non-hygroscopic, oil resistant, flame resistant



- (b) Starting duty : Two hot starts in succession, with motor initially at normal running temperature
- (c) 11 kV / 3.3 kV AC motors : Class F: with winding temperature rise limited to class B. They shall withstand 1.2/50 micro sec switching surges of $4U+5$ KV (U=Line voltage in KV). The coil inter-turn insulation shall be suitable for 0.3/3 micro sec. surge of 32 KVp and 12 kVp for 11 kV and 3.3 kV system respectively followed by 1 min power frequency high voltage test of appropriate voltage on inter turn insulation.
- (d) 415V AC & 220V DC motors : Class 'F' with temperature rise limited to class 'B'
- 4.00.04 Motors rated above 1000 kW shall have insulated bearings to prevent flow of shaft currents.
- 4.00.05 Motors with heat exchangers shall have dial type thermometer with adjustable alarm contacts to indicate inlet and outlet primary air temperature.
- 4.00.06 Noise level and vibration shall be limited within the limits prescribed in IS: 12065 & IS: 12075 respectively. Motors shall withstand vibrations produced by driven equipment.
- 4.00.07 In MV/HV motors, 12 nos. simplex or 6 nos. duplex RTDs (two per phase), each having D.C. resistance of 100 ohms at 0°C, embedded in the stator winding at locations where highest temperatures may be expected, shall be provided. The material of the ETD's shall be platinum. Each bearing shall be provided with dial type thermometer with adjustable alarm contact and resistance type temperature detector. All HV motors shall be provided with shaft grounding rings for bearing protection and earthing shaft current.
- 4.00.08 MV/HV motors shall also be capable of satisfactory operation at full load at a supply voltage of 80% of the rated voltage and shall be capable of either two starts in quick succession with third start after 5 minutes in cold condition or two starts at 15 minutes intervals in hot condition, both cases with voltage and frequency variation within specified limits.
- 4.00.09 Locked rotor current of the MV motors shall be limited to 600% (subject to IS tolerance) of the full load current of the motors and for HV motor shall be limited to 450% (inclusive of IS tolerance) of full load current of the motor.



Locked rotor current of the LV motor shall not exceed 600% of full load current inclusive of IS tolerance.

- 4.00.10 MV Motors shall be provided with differential protection. These motors shall be provided with star connected stator windings. The 3 nos. current transformers, one for each phase shall be mounted in a separate compartment in the neutral side terminal box. The three phases shall be connected to form the star point after they pass through the CTs. These differential protection CTs shall be supplied loose by 11/ 3.3 kV switchgear manufacturer.
- 4.00.11 Motor body shall be grounded at two earthing points on opposite sides with two separate and distinct grounding pads complete with tapped holes, GI bolts and washers.
- 4.00.12 HV motors can be offered with either elastimould termination or dust tight phase separated double walled (metallic as well as insulated barrier) cable boxes. In case elastimould terminations are offered, then protective cover and trifurcating sleeves shall also be provided. Removable gland plates of thickness 3 mm (hot/cold rolled sheet steel) or 4 mm (non magnetic material for single core cables) shall be provided in case of cable boxes.
- 4.00.13 All motors shall be so designed that maximum inrush currents and locked rotor and pullout torque developed by them at extreme voltage and frequency variations do not endanger the motor and driven equipment.
- 4.00.14 The motors shall be suitable for bus transfer schemes provided on the 11 kV, 3.3 kV/415V systems without any injurious effect on its life.
- 4.00.15 All motors below 15 kW shall be provided with sealed ZZ bearings.
- 4.00.16 For motors rated 1000 KW & above, neutral current transformers of PS class shall be provided on each phase in a separate neutral terminal box.
- 4.00.17 All motors shall be provided with an emergency stop push button near the motor as per the Indian Statutory regulations.
- 4.00.18 The motor terminal box shall be suitable for withstanding the maximum system fault current for a duration of at least 0.25 seconds.
- 4.00.19 Neutral in case of HV motors shall be kept accessible.



- 4.00.20 Motors shall be designed to easy access for drilling holes through motor feed of mounting flange for installation of dowel pins after assembly of the motor and driven equipment.
- 4.00.21 Well spacious working platforms shall be provided around the motor area for carrying out maintenance & testing works. Platform shall be minimum of 300 mm below the level of motor base plate.
- 4.00.22 Flow switches shall be provided for monitoring oil flow of forced lubrication bearings, if used. Alarm switch contact rating shall be minimum 0.5 A at 220 V DC and 10 A at 230 V AC.
- 4.00.23 For bearing temperature measurement, duplex RTDs shall be provided for each bearing and shall be wired up to the terminal box..
- 4.00.24 Lube oil pressure transmitters shall be provided to DCS for remote monitoring. Lube oil pressure very low trip to HV equipment shall be 2 out of 3 logic.
- 4.00.25 Capillary type temperature gauge cum switch shall be provided for DE / NDE of HV Motors
- 4.00.26 Motors with CACA/CACW heat exchangers shall have dial type thermometer with adjustable alarm contacts to indicate the following:
- Hot and cold air temperatures of the closed air circuit for CACA motors.
 - Hot and cold, air and water temperatures for CACW motors.
- The Alarm switch contact rating shall be minimum 0.5 A at 220 V DC and 10 A at 230 V AC.

4.00.27 Lifting Provisions

Motor weighing 25 kg or more shall be provided with eye bolt or other adequate provision for shifting. Electrical hoists shall be provided for motors above 1000 kgs for maintenance of the same.

4.00.28 DC MOTORS

DC motors shall be provided where specified/required. DC Motors shall be sized for operation with fixed resistance starting for reliability. DC motors shall be shunt wound type. Motors shall be capable of delivering the rated output at 220 V DC with (+) 10% and (-) 15% variations without exceeding its guaranteed temperature limits. 220 V DC



system shall be unearthed. Starting current of the DC motors shall be limited to 200% of the full load current of the motor, and is subject to IS tolerance. DC Motors shall be similar to AC Motors with respect to other features like enclosure type, cooling and class of insulation

4.00.30 Painting

Motor including fan shall be painted with corrosion proof paints of colour shade Siemens grey (RAL 7032).

4.00.31 Local Push Button Stations

The LPBS shall be installed near the motors to be controlled. Individual channel supports shall be used for each LPBS. These shall be installed as per approved erection detail drawing. LPBS for hazardous areas shall be CMRS certified and CCE approved.

All LPBS shall have necessary canopies. Wiring of LPBS shall be checked before giving control supply.

5.00.00 LIST OF TESTS TO BE CONDUCTED FOR HV, MV and LV MOTORS

5.01.00 TYPE TESTS

- (a) No load saturation and loss curves up to approximately 115% of rated voltage
- (b) Momentary overload test
- (c) Temperature rise test at rated conditions. During heat run test, bearing temp., winding temp., core temp., coolant flow and its temperature shall also be measured. In case the temperature rise test is carried at load other than rated load, specific approval for the test method and procedure is required to be obtained. Wherever ETD's are provided, the temperature shall be measured by ETD's also for the record purpose.
- (d) Surge withstand test on the sample coil after placing it in stator core at $(4U + 5 \text{ KV})$ and with at least five impulse of 1.2/50 micro sec. wave, for HV motors only, where U is the line to line voltage in kV.
- (e) Surge-withstand test with 0.3/3 micro sec. wave on each type of 3.3/11 kV motor coils with at least five such impulses, followed by one minute power frequency high voltage test on turn to turn insulation, after cutting the coil and bringing out



the turns suitably. The power frequency test voltage shall be decided during detailed engineering.

- f) Dimensions (for motors covered by IS 1231:1974 and IS 2223:1983 only)
- g) Measurement of resistance of windings of stator and wound rotor.
- h) Reduced voltage running up test at no load (for squirrel cage motors up to 37kw only)
- i) Full load test to determine efficiency, power factor and slip.
- j) Insulation resistance test
- k) Test for vibration severity of motor
- l) Test for noise levels of motor
- m) Test for degree of protection by enclosure
- n) Temperature rise test at limiting values of voltage and frequency variations
- o) Over speed test

5.02.00 ROUTINE TESTS

The following shall constitute the routine tests.

- a) Insulation resistance test
- b) Measurement of resistance of windings of stator and wound rotor.
- c) No load test
- d) Locked rotor readings of voltage, current and power input at a suitable reduced voltage
- e) Reduced voltage running up test (for squirrel cage motor)
- f) Open circuit voltage ratio of stator and rotor windings (for slip ring motors); rotor;
- g) High voltage test

6.00.00 INSPECTION AND TESTING AT SITE

6.01.01 Insulation resistance of 415V motors shall be measured between the winding of the machine and its frame by means of a 500/1000V megger. A minimum value of 1 mega ohm for 415V motors shall be considered a safe value. In case of lower I.R. Value, the insulation value shall be brought up by any of the following methods as desired by the Site Engineer:

- (a.) Blowing hot air in case of big motors.
- (b.) Putting the motor in electric oven in case of smaller motors.
- (c.) Placing heaters or lamps around and inside in case of small motors after making suitable guarding and covering arrangements so as to conserve the heat.



6.01.02

Site Test

- (a.) Measurement of vibration.
- (b.) Measurement of insulation resistance and polarization index.
- (c.) Measurement of full load current.
- (d.) Test running of the motors, checking the temperature rise and identifying the hot spot etc.

6.01.03

3.3 kV motors shall be tested for insulation by 500/1000V megger and its value should not be less than the safe minimum insulation of $\geq 20 \text{ M}\Omega$ resistance at 60 deg. C. In case the insulation is low, the following method of drying has to be adopted:

- a. By locking the motor so that it cannot rotate and then applying such a low voltage to the stator terminals that full load current flows in the stator, keeping the stator winding temperature below 90 deg. C. In this a close watch shall be kept for any possible overheating and I.R. Values vs. temperature shall be plotted and heating continued till I.R. Value becomes steady.
- b. By blasting hot air from external source, Maximum temperature of winding while drying should be 70 deg. C to 80 deg. C. (Thermometer) or 90 deg. C. to 95 deg. C. by resistance method. Heating should be done slowly till steady temperature of winding is reached after 4 to 5 hours and for large machines after 10 hours. A record has to be kept for drying process, with half an hour readings and, after steady temperature is reached, at an interval of 2 hours. In case it is essential, the drying process can be supplemented by blower.





TITLE : TECHNICAL SPECIFICATION
FOR
SELF CLEANING STRAINERS

SPEC. NO. PE-TS- 412-165-N003

VOLUME : IIB

SECTION : C

REV. NO. 0

DATE :
16.06.15

SHEET 1 of 1

SECTION C3

SELF CLEANING STRAINERS

(C&I DETAILS)

SELF CLEANING STRAINER -C&I REQUIREMENTS

S.NO.	PROJECT	2x 660 MW ENNORE
1.00	SYSTEM	SCS
2.00	COMMON / PER UNIT	PER UNIT
3.00	CONTROL SYSTEM	DCS
4.00	LOCATION OF CONTROL SYSTEM	CCR/CWPH
4.10	CONTROL SYSTEM SCOPE (BIDDER/ BHEL/ CUSTOMER)	BHEL
5.00	HARDWIRED INTERFACE WITH DCS (Y/N)	N
6.00	SOFTLINK TO DCS (Y/N)	Y(CONNECTED WITH MAIN PLANT DCS THROUGH MAXNET)
7.00	PROTECTION CLASS FOR PLC / RIO PANEL	NA
8.00	CONTROL FROM PB's ON LCP/OWS	CONTROL FROM PB's ON LCP/OWS
9.00	ANNUNCIATION ON LCP (Y/N) -- IF Y, MIN NO. OF HARDWIRED ALARMS / INDICATIONS	LCP FOR ANNUNCIATION, INDICATORS & AMMETERS
9.10	MIMIC ON LCP (Y/N)	Y
10.00	CONTROL FROM DCS IN CCR (Y/N)	Y
11.00	TYPE OF SOFTLINK (TPI/FC)	NA
11.10	COMMUNICATION CABLE SCOPE (BIDDER/ BHEL)	NA
11.20	REDUNDANT CABLE (Y/N)	NA
11.30	PROTOCOL	NA
12.00	RIO / RPU (Y/N)	NA
13.00	## NO. OF OWS / LAPTOP/LCD	NA
13.10	SIZE OF OWS/ CRT OR LCD	NA
14.00	NO. OF PRINTER	NA
14.10	PRINTER SIZE AND TYPE	NA
15.00	POWER SUPPLY AVAILABLE FOR BALL MONITOR (24V DC / 110 V AC UPS / 230 V AC UPS)	24VDC
16.00	ACTUATOR WITH INTEGRAL STARTER (Y/N)	Y
17.00	PG/ DPG/ PS/ DPS/ PT/ DPT per Balls Collecting Strainer/DF/SCS	DPT = 2 nos. DPI = 1 no. (ACROSS EACH BALL SEPARATOR)

SELF CLEANING STRAINER -C&I REQUIREMENTS

S.NO.	PROJECT	2x 660 MW ENNORE
19.00	PROJECT SPECIFIC INFO	Y
20.00	REMARKS	
21.00	NOTES:	
	1. COMPLETE CONTROL & INSTRUMENTAION OF SCS IS IN BIDDER SCOPE OF SUPPLY. ITEMS NOT SPECIFICALLY MENTIONED & REQUIRED FOR THE COMPLETENESS OF THE SYSTEM SHALL BE SUPPLIED BY BIDDER.	
	2. IN CASE OF DCS CONTROLLED SYSTEMS, BIDDER TO TERMINATE ALL INSTRUMENTATION AND CONTROL ELEMENTS IN JUNCTION BOXES FOR FURTHER CABLING TO DCS BY BHEL/CUSTOMER. BIDDER TO PROVIDE INPUT/OUTPUT LIST, DRIVES LIST, JUNCTION BOX SCHEDULE AND TERMINATION DETAILS, RECOMMENDED CONTROL LOGICS / WRITE-UP ETC. DURING DETAILED ENGINEERING. COMPLETE CABLE SCHEDULE (IN BHEL EXCEL FORMAT PROVIDED IN ELECTRICAL PORTION OF THE SPECIFICATION) & CABLE INTERCONNECTION DETAILS FROM FIELD TO JB/LCP & JB/LCP TO DCS SHALL BE PROVIDED BY BIDDER .	
	3. ALL THE INSTRUMENTS ALONG WITH NECESSARY FITTINGS, ACCESSORIES AND VALVE MANIFOLD ETC., INSTRUMENT RACK & JUNCTION BOXES, ERECTION HARDWARE SHALL BE IN BIDDER SCOPE OF SUPPLY.	
	4. INSTRUMENT RACK AND JUNCTION BOXES SHALL BE IN BIDDER'S SCOPE OF SUPPLY.	
	5. BIDDER TO FURNISH ELECTRICAL LOAD DATA DURING DETAILED ENGINEERING.	
	6. ALARM FACIA SHALL BE UNDER BIDDER'S SCOPE. NUMBER OF FACIA SHALL BE DECIDED DURING DETAILED ENGINEERING.	
	7.THE SCOPE OF CABLE SHALL BE REFERRED IN ELECTRICAL SCOPE SPLIT SHEET IN ELECTRICAL PORTION OF THE SPECIFICATION.	
	LEGEND:	
	CCR- COMMON CONTROL ROOM	
	DCS- DISTRIBUTED CONTROL SYSTEM	
	PLC- PROGRAMMABLE LOGIC CONTROLLER	
	RPU - REMOTE PROCESSING UNIT	

STANDARD BLOCK DIAGRAM FOR SCS PACKAGE WITH DCS

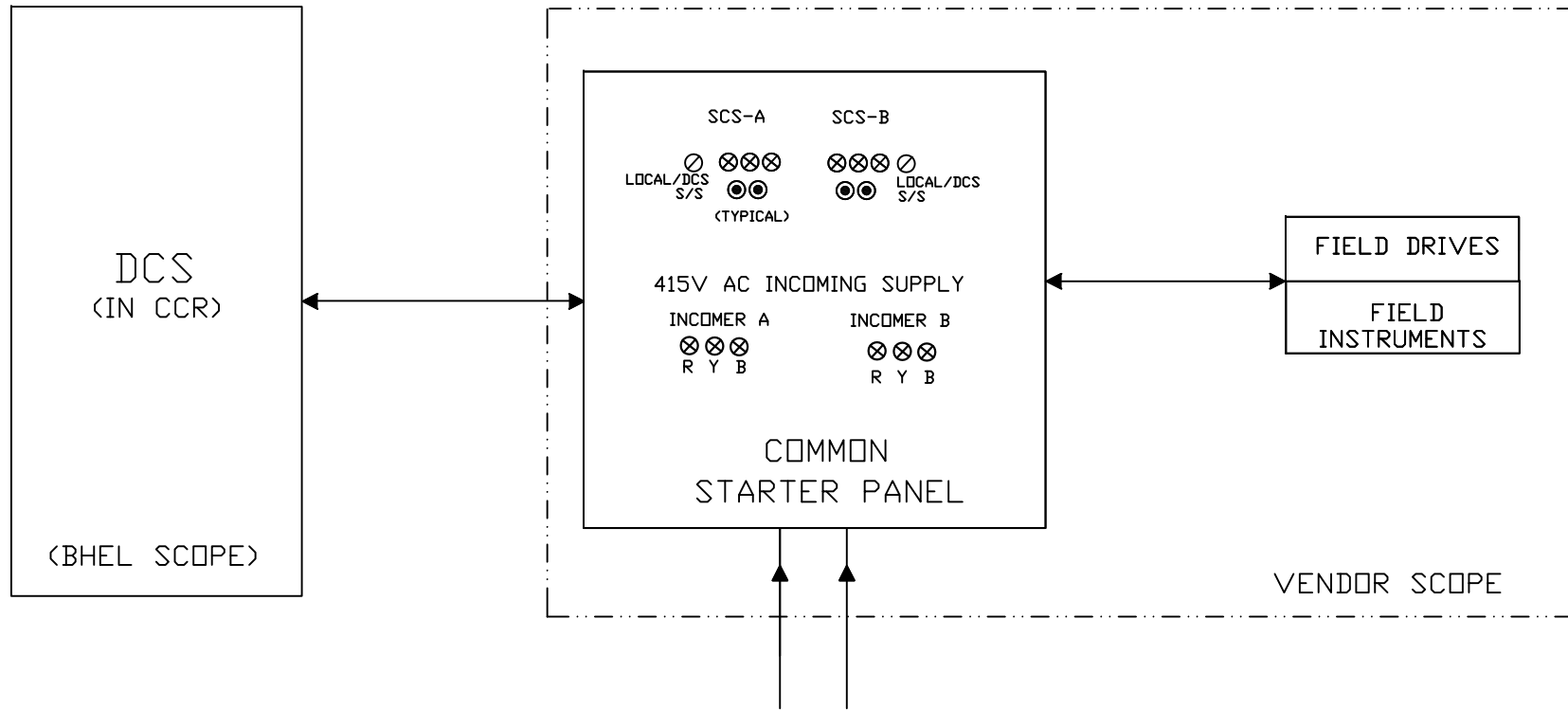

NOTE:-

1. COMMON LCP FOR L & R STREAM HOUSING PB , LAMPS ETC.
2. SIGNALS FOR FIELD INSTR. & FOR 'BID' DRIVES WITH INTEGRAL STARTER SHALL BE ROUTED TO DCS THROUGH STARTER PANEL.

**A.GENERAL
&
SPECIFIC
TECHINICAL
REQUIREMENT**

Specific Technical Requirements

- 1) All motorised valves of 200NB or more than 200NB size shall be provided with integral motorized bypass valves on all process lines.
- 2) Components of instruments, control devices, accessories, piping etc. which contact with steam, condensate or boiler feed water shall be manufactured from copper free materials which do not react with media at operating parameters.
- 3) Valve end position (Open & Close) shall be monitored for the manual critical valves, wherever provided.
- 4) All the instruments/drives shall be terminated on JBs/Panels in field. JBs/Panels shall be in Bidder's scope.
- 5) Scope of Instrumentation cables (Screened Control Cables), Fibre Optic cable & Control cables shall be as per Electrical Cable scope matrix in Electrical portion of specification.
- 6) Bidder to comply with codes and standards as mentioned in the specification.
- 7) Bidder shall provide an unlimited warranty on all equipment and software for three years after the start of the warranty period, i.e. after satisfactory completion of initial operations. This warranty shall include repair, replacement or correction of identified software or hardware discrepancies at no cost to OWNER.
- 8) All local gauges, transmitters and switches shall be mounted on suitable enclosures, racks subject to owner's approval. All transmitters shall be HART compatible.
- 9) Bidder to delegate /depute their persons/experts as per owner/consultants' requirement.
- 10) Bidder must offer general tools and tackles and special calibration instruments required during start-up, trial run, operation and maintenance of the system.
- 11) The above given scope is indicative & minimum. Any item/ equipment not indicated above however required for the completeness of the system is to be supplied by bidder without any technical, commercial and delivery implication to BHEL.
- 12) Bidder shall provide Cable Schedule in BHEL excel format provided in Electrical portion of the specification. Also, Cable Interconnections details for Complete System shall be in Bidder's scope.

Specific Technical Requirements

13) All the instruments/equipment/electrical items shall be provided & designed with maximum star rating as available in line with energy conservation policies notified by BEE, GOI at the time of supply.

14) Each communication Network shall be industrial grade and shall be provided with industrial grade managed type Ethernet switches, external surge protection system/devices and industrial firewall. Industrial grade managed type Ethernet switches shall be provided with in built diagnostic features, 20% spare parts & in built redundant power supply.

15) All approval/Inspection are to be carried out by Owner or owner appointed agency only.

16) The make/model of various instruments/items/systems shall be subject to approval of owner/purchaser during detailed engineering stage. No commercial implication in this regard shall be acceptable. In case of any conflict and repetition of clauses in the specification, the more stringent requirements among them are to be complied with.

17) Each of the Plant Auxiliaries & off site systems shall be provided with annunciation system. It shall be an integral part of the control system. All the field contact for this purpose shall be acquired through control system. The annunciation sequence/logic shall conform to ISA sequence ISA-2A. The window lamps for the system shall be driven through output modules of the control system.

18) The instrumentation to be provided for each of the plant auxiliary & Off Site Plant systems shall be as per the technical specification document / drawings wherever provided for the respective systems as a minimum requirement for bidding purpose. However, for completeness of each of the plant auxiliary & Off Site system and its associated equipment, Bidder shall also provide all the necessary instruments to the process requirement even if it is not specifically indicated in the given technical Specification document / drawings.

19) All cables terminated in the terminal block, power distribution scheme instruments shall be ferruled. Ferruling shall be double cross ferruling (i.e.) source and destination addresses shall be marked on both sides of the tube ferruling.

Specific Technical Requirements

20) Bidder shall provide local panel for local start/ stop monitoring of auxiliaries and equipment as per requirement .The requirement shall be decided during detailed engineering. All local panel shall be NEMA 4X with canopy.



**SPECIFICATION FOR
CONTROL & INSTRUMENTATION FOR AUX
PACKAGES**

SPECIFICATION NO.:

VOLUME

SUB SECTION

REV. NO.

DATE :

SHEET

OF

GENERAL REQUIREMENT

- 1.0 Bidder shall provide complete and independent control & instrumentation system with all accessories, auxiliaries and associated equipments for the safe, efficient and reliable operation of auxiliary systems.
- 2.0 The quantity of instruments for auxiliary system shall be as per tender P & ID wherever provided of the respective system as a minimum, for bidding purpose. However, Bidder shall also include in his proposal all the instruments and devices that are needed for the completeness of the plant auxiliary system/ equipment supplied by the bidder, even if the same is not specifically appearing in the P & ID. During detail engineering if any additional instruments are required for safe & reliable operation of plant, bidder shall supply the same without any price implication.
- 3.0 Measuring instruments/equipment and subsystems offered by the bidder shall be from reputed experienced manufacturers of specified type and range of equipment, whose guaranteed and trouble free operation has been proven. Further all the instruments shall be of proven reliability, accuracy, and acceptable international standards and shall be subject to employer's approval. All instrumentation equipment and accessories under this specification shall be furnished as per technical specification, ranges, makes/ numbers as approved by the employer' during detail engineering.
- 4.0 The necessary root valves, impulse piping, drain cocks, gauge-zeroing cocks, valve manifold and all the other accessories required for mounting/ erection of these local instruments shall be furnished, even if not specifically asked for, on as required basis. The contacts of equipment mounted instruments; sensors, switches etc for external connection including spare contacts shall be wired out to suitably located junction boxes.
- 5.0 The customer specification attached as Specific Technical Requirement will supercede the Data sheets, if there is any mismatch.

For sea water application, MOC of C&I instruments and related accessories shall be Duplex SS (Refer data sheet A of Section D1)

3.03.00 TRANSMITTERS, SWITCHES, GAUGES AND PANEL MOUNTED INSTRUMENTS

3.03.01 Pressure, Differential Pressure, DP type Level and Flow Transmitters (PT, DPT, LT & FT)

Smart Transmitters of the electronic type shall be furnished.

All Transmitter shall be installed in closed LIE in the boiler area. Similarly transmitter for TG shall also be in LIE except the transmitters located in covered area on TG floor and these shall be mounted in LIR.

Transmitters shall be equipped with mounting brackets suitable for a mounting in transmitter enclosures.

In general, Transmitters are envisaged to be grouped at several places as to be decided during detailed engg. stage. For this purpose, suitable enclosures complete with all tubing, fittings, purge meters, loop cable trays etc. shall be provided.

Type/Construction	:	Sealed capacitance/ Inductance/ Silicon resonance type
Material		
- Body	:	Die cast Aluminum with epoxy coating for air & flue gas SS316 for other services
- Diaphragm	:	316 SS
- Measurement element	:	Teflon seal
- Valves	:	Carbon steel for non-corrosive Applications SS316 for corrosive applications.
Output signal	:	4 to 20 m Amp. DC (Two wires) HART Compatible
Local Indicator	:	LCD indicator (5 digit) with scale of Engg. unit
Overall Accuracy	:	$\pm 0.04\%$ or better of Span for BTG package $\pm 0.065\%$ or better of Span for BOP packages $\pm 0.2\%$ or better of span for remote seal type transmitter.
Turn down ratio	:	100:1 in general
Stability	:	$\pm 0.15\%$ of URL for 5 years.
Response time	:	150 msec.
Power supply	:	24V DC nominal
Drive capability	:	600 Ohms nominal
Enclosure Class	:	IP-65 (Explosion proof for NEC Class-1, Division 1 area)
Span and Zero	:	Locally adjustable, non-interacting



Zero suppression / elevation : At least 100% of Span

Connection

- Process : 1. Half (1/2) inch NPT (F)
Quarter (1/4) inch NPT
with/without oval flanges
- Electrical : Suitable for Plug in type connection (Both side of transmitter), unused entry with blind plug.

Accessories

- For Absolute Pressure Transmitters: Two (2) valve SS316 manifold
- For Gauge & Vacuum pressure transmitter : Three (3) valve SS316 manifold
- For DP, level & flow transmitter : Five (5) valve SS316 manifold
- For oil and corrosive liquids : Separator diaphragm seals
- For all transmitters : Mounting bracket

Manifold should not be mounted on the transmitter, Manifold shall be non integral and standalone type. Snubbers/Pulsation dampners shall be used where the process media is unstable for measurement such as the discharge of a pump. Over range protection shall be used where necessary. The coil syphons & condensate pots shall be used for steam services. Transmitters shall be provided with suitable drain & vent points.

3.03.01.01 Transmitters & other HART based instruments shall be supplied along with 3 Nos. of universal type hand held/portable pressure calibrators. Temperature transmitters shall be supplied along with 3 Nos. of hand held/portable mV source generators.

3.03.02 PRESSURE SWITCHES (PS) & DIFFERENTIAL PRESSURE SWITCHES (DPS)

Applicable Standards : IS3624 - 1966/ISA-RP-8.1 except as modified in spec.

Type/Construction : Bourdon/Sealed Diaphragm Piston Actuated preferable. Indicators with contacts are not acceptable.

Materials

- Bellows : 316 SS
- Bourdon tube : 316 SS
- Movement : 316 SS
- Enclouser : Die-cast aluminum with stoved enamel black finish. Epoxy coating shall be provided for corrosive atmosphere.
- Protective Diaphragm : Teflon



Accuracy	:	\pm One (1) percent or better
Repeatability	:	\pm 0.5(half) percent or better
Setting & Differential	:	Adjustable
Contact		
- Number	:	DPDT /2 SPDT
- Type	:	Auto reset with internal Adjustable snap action micro switch
- Rating	:	5 Amp, 240V AC / 0.2 Amp, 220V DC
Connection - instrument	:	Half (1/2) inch NPT Male Process
Electrical	:	Suitable for Plug in type connection. All the switches are internally connected and brought to the surface with Amphenol male/female connection. Cabling need not terminated inside the switch. Cable ends are to be soldered in connector and to be inserted for easy maintenance.
- Over range protection	:	One Fifty (150) percent of full scale
Enclosure Class	:	IP-65 or better (Explosion/Flame proof for NEC Class-1, Division 1 area)
Accessories		
- 3 / 5 valve manifold	:	As applicable for all switches
- Self cleaning type pulsation dampners/Snubber (Material SS316)	:	Pump and compressor discharge lines
- Syphon	:	For all steam lines
- Protective separating diaphragm	:	For fuel oil & corrosive liquid lines.
Mounting	:	Local (in LIE/LIR for BTG package)

3.03.03 PRESSURE & DIFFERENTIAL PRESSURE GAUGES (PG & DPG)

Applicable standard	:	IS:3602-1966, IS/3624, ASME B 40.1
Type/Construction	:	
-760 mm to 1.0Kg/cm2	:	Bellows/Diaphragm
-Above1.0Kg/cm2	:	Bourdon Tube
- Suction side of pumps	:	Compound gauge
Materials		
- Bourdon tube	:	316 SS
- Bellows	:	316 SS
- Movement	:	316 SS
- Case	:	SS 316/ Die-cast aluminum with stoved enamel black finish. Epoxy coating



		shall be provided for corrosive atmosphere.
- Protective Diaphragm	:	Teflon
Dial size	:	150mm with shatter proof glass
Scale Details	:	Graduations in black lines on white dial, on white dial, 270 Deg. pointer deflection scale provided with glass cover. Smallest scale division shall be one (1) percent of full scale value or smaller. Pointer stop for all gauges.
Accuracy	:	\pm One (1) percent or better
Connection - Instrument Process	:	1/2 inch NPT Male Bottom
Mounting	:	Local
	:	1/2 inch NPT Male (Back entry) mounted on local gauge board.
Enclosure Class	:	IP-65 or better (Explosion/Flame proof for NEC Class-1, Division 1 area)

Accessories

- 3 way needle valve/manifolds	:	For all gauges
- Self cleaning type Pulsation dampener/snubber (S316)	:	Pump and compressor discharge lines
- Syphon	:	For all steam lines
- Protective separating	:	For fuel oil and corrosive liquid lines

Other particulars

- External Zero adjustment	:	For all gauges
- Safety device		
Ranges 5 to 20 Kg/cm ²	:	Rubber blow out disc with open front construction.
Ranges above 20 Kg/cm ²	:	Neoprene safety diaphragm at the back with solid front construction.
- Over range protection	:	One Fifty (150) percent of full scale

Other Requirments

	:	Movement mechanism shall be glycerin filled for oil services & vibration prone area.
	:	For Fuel oil & corrosive liquid lines diaphragm type sensors required. Armored capillary of 10 M for Fuel oil & Corrosive liquid service.



- : Contact type pressure gauges are not acceptable for interlock & protection.
- : For condensate storage tank the pressure gauge in terms of 0-10000 mm wc or suitable range having **dial size of 300mm or bigger size** shall be provided.

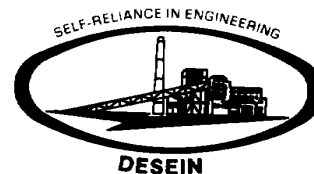

SPECIFICATION
FOR
CONTROL PANELS

CHAPTER-6**SUPERVISORY CONTROL PANELS, SUPERVISORY CONTROL DESKS,
EQUIPMENT PANELS****6.00.00 PANEL AND DESKS****6.01.00 GENERAL REQUIREMENTS**

All DDCMIS/PLC/any other control system's electronic modules, power supply components, other control devices (except field mounted sensors/transmitters) and required for completeness of the system shall be housed in cabinets furnished by the Bidder. All equipment and dedicated cabinets required for termination, marshalling and proper interface within Bidder's system and also with other systems shall also be provided by the Bidder.

The cabinet mounted equipments shall be fully assembled, installed in mounting racks, wired and fully tested as per specification requirements and Owner approved drawings in the manufacturing works of a qualified manufacturer prior to shipment to the project site. The Bidder shall ensure that the cabinets are complete and ready for installation before dispatch from manufacturing works. The installation work at project site for these cabinets should only involve connections through multi pair cables from marshalling cabinets (wherever provided) to system cabinets and inter-cabinet/cabinet to UCD/UCP/BUP.

The Control cabinets shall house all types of modules / hardware to achieve all functions of Control System including signal conditioning modules, controller modules, I/O modules, communication controller modules, and all other requisite hardware for a complete system.

6.02.00 SUPERVISORY CONTROL PANELS AND DESKS**6.02.01 Control Desks & Other Furnitures**

Supervisory control desks for DDCMIS and other systems shall be supplied for mounting the required operating station as specified elsewhere in the specification. Also control desk will be provided for balance work stations – located in computer room, supervisor room etc. All furniture including chairs and tables for printers etc. shall also be provided by the bidder.

Also control desk & complete furniture will be provided for work stations & printers – located in respective control room for BOP packages.

Industry standard Cushioned revolving, wheel, independently, adjustable seat and back chairs with provision for adjustment of height shall be provided for the operator & unit in charge & other personnel in central control room area & BOP's control rooms, simulator rooms, Conference room, meeting room, documentation room, staff room, CAAQMS shelters, CAAQMS room etc. These shall be designed for sitting for long duration such that these are comfortable for the back. The exact details shall be finalised & approved by Owner during detailed engg.

The actual nos., placement and profile of the main plant control room desk shall be decided during the detailed Engineering.



The tentative layout of central control desk, LVS & consoles are shown in the Drg. No. 114-05-0108, 0105 & 0111.

Control Desk for programmer's, Maintenance Engineer's, EWS, Serves, PC & diagnostic OWSs: -

Required numbers of control desks for accommodating programmer's/main-tenance engineer's/diagnostic etc shall be supplied. These shall preferably have the same dimension as that of supervisory control desks. Also required nos. of control desk will be provided for work stations & printers – located in respective control room for BOP packages.

Desks for accommodating printer:

Adequate number of table/desks/stands for accommodating printers in bidder's scope shall be supplied. Each printer shall be on a separate table / stand.

Care shall be taken to ensure ergonomically aspects so as to create ergonomically ideal work place considering physical aspects such as an average Indian person's size and reach, physiological aspects such as line of sight and field of vision and cognitive factors such as concentration and perceptivity. Extreme care shall be taken to design the desks with correct angles and dimensions.

Glass top teak wood office table with lockable drawers shall be provided for Chief Engineer room and all other executive rooms.

6.02.02 Supervisory Panel Unit Control Panel

In addition to the LVS and OWS, a limited operation from backup unit control panel is envisaged for emergency operation and to provide safe shut down of plant. The Unit control panel shall housed Conventional Push-button (ILPB) stations, Console inserts (for SG, TG & Generator like FSSS, HPBP, SADC, APRDS, ATRS, ATT, DEHC, LPBP etc), Trip Push Buttons, EWLI, Ammeters, chartless recorders, & min. 15 nos. programmable digital display units for Boiler, Turbine & Generator's parameters. The mosaic grid shall be heat resistant, flame retardant, self extinguishing, and shrinkage free, non reflecting type. Finish of mosaic grid shall be mat type with out flaring. Hard wired emergency trip pushbuttons shall be arranged on operator station desk & in parallel on UCP.

Unit control Panel (UCP), shall be located suitably in the CCR.

In addition to above, 21 nos. Programmable digital display units common for both units showing total MW shall be provided by bidder at different locations of plant. The data to this DDU will be fed from DDCMIS through MOD BUS/PROFI BUS /RS 485 protocol and not hard wired. The **digit size** of the display unit will be **300 mm for 6 Nos.** and **200 mm for 15 Nos.** The placements/locations shall be decided during detailed Engineering.

Control panel cum desk with HW annunciation windows, ILPBs, Ammeters, Annunciation & desk PBs, mimic, lamps, Indicators, recorders, etc. shall be provided as per Annexure A – Control System Philosophy for BOP packages.



(Exact service & quantities will be worked out & approved during detailed engineering by owner).

6.02.03 Two (2) nos. vertical Steel Almirahs shall be provided for keeping documents in each BOP package's control room. Glass doors for each rack shall be provided such that the documents are visible from outside. Size of the rack shall be sufficient to easily fit technical manuals. The exact details shall be approved by Owner during detailed engg.

Suitable lockers (min. 24 nos. per unit) shall be provided in the room adjacent to the each central unit control room for storing of personal articles of control room personnel. Similarly suitable lockers (min. 8 nos. in each control room) shall be provided in BOP package control rooms for storing of personal articles of control room personnel. Also, vertical steel almirahs (min. 4 nos. per unit) shall be provided in Documentation Room for storing of documents.

Vertical Steel Almirahs shall also be provided for the following rooms, wherein final quantity may be decided by owner during detailed engineering

- a. Maintenance room – 6 nos. min. (per Unit)
- b. ERP room – 2 nos. min (Common for both unit).
- c. PADO Room – One (1) no. min.(per unit)
- d. Station In charge room – One (1) no. min (common for both unit).
- e. Simulator room – 4 nos. min. (per Unit)

Thickness of steel almirah sheet shall be 18 gauges.

In addition to above, All industry grade furniture including chairs, control tables, tables for printers etc. & Almirahs for storage of consumables/catalogues/manuals shall also be provided by the bidder as on required basis and finalized by owner any where in power plant. Details shall be finalised and approved by Owner during detailed engineering.

6.02.04 Control panels for service system like C.W. Pumps etc. will be located in the respective control room. In addition, some local panels will be provided near respective system/equipment such as Boiler Feed Pump, Hydrogen seal oil system, Electrostatic precipitator etc.

6.03.00 TERMINATION/Marshalling CABINETS & Interposing Relay Panel

Marshalling/Termination cabinets for the control system shall be supplied for terminating all cables originating from the field, MCC/SWGR or any other source of signal and for distributing the signals to different functional panels, MCC/SWGR and control cubicles.

Incoming cables from the field, MCC/SWGR or any other source of signal shall be terminated in suitable terminal blocks in logical sequence.

Prefabricated cables with plug in connectors at both ends shall be used for extending the signals to the functional panels. Matching plug sockets shall be provided in the termination cabinets for terminating the plugs.



Interposing relay panels for the system shall be supplied for mounting interposing relays & terminating all cables originating from the DO cards in case of solenoid valves, and other required services etc. IPR panels shall be placed in CER and LCR.

Interposing relay shall be mounted in respective SWGR/MCC/integral starter required for commands signals of HT/LT unidirectional drives and bidirectional drives, breakers, isolators & bus couplers etc from DDCMIS/DCS/PLC or any control system.

Terminal blocks shall be located inside the cabinets on support wings fabricated of metal plates.

The plug socket shall be mounted on hinged plates to provide an access to the rear pins of the plugs.

General features of termination cabinets and accessories shall conform to the general design and construction specification of panels. Terminal blocks shall be Rail mounted Terminal blocks (Screw less cage clamp type) with markers.

6.04.00

CONSTRUCTIONAL FEATURES OF PANELS, CONSOLES, CONTROL DESK, CUBICLES & ENCLOSURES

All panels, cubicles, consoles, SOV panels and enclosures furnished as per this specification shall be of free standing type and shall be constructed of specified gauge of steel plates. The panel sheet thickness shall be not less than 2 mm unless otherwise specified herein.

The panels, consoles/desks shall be reinforced as required to ensure true surfaces and adequate support for instruments mounted thereon. All instrument cutouts, mounting studs, and support brackets shall be accurately located. All welds on the exposed panel surfaces shall be ground smooth. Finished panel surfaces shall be free from waves, bellies, or other imperfections. Unless specified, otherwise, panel doors shall be 4 points hinged and shall have turned back edges and additional bracing where required to ensure rigidity. Door hinges shall be of the concealed type. Door latches shall be of the three-point type to ensure tight closing. Door locks shall be furnished which will allow actuation of all locks by a single master key. All panels shall have removable lifting eyebolts for safe lifting from top during storage and installation handling.

Cabinet doors shall be hinged and shall have turned back edges and additional bracing where required ensuring rigidity. Hinges shall be of concealed type. Door latches shall be of three/four-point type to assure tight closing. Detachable lifting eyes or angles shall be furnished at the top of each separately shipped section and all necessary provisions shall be made to facilitate handling without damage. Front and rear doors shall be provided with locking arrangements with a master key for all cabinets. If width of a cabinet is equal or more than 800 mm, double doors shall be provided.

All panels shall be mounted on vibration dampers, which are secured to channels mounted on the floor. The channels shall be field welded to steel plates set into the concrete flooring. The steel plates shall be located such as to approximate the outline of panel bases. The exact mounting details shall be as approved by the owner during detailed engineering stage. All panels shall be provided with adequate ventilation and packaging density of components shall be restricted so as to limit the temperature rise



above ambient to 10° C under the worst conditions. All panels shall have auto on/off switch for internal lighting. All the power supply circuit for control panels shall be provided with auto changeover circuitry.

In each panel /cabinet, a 24 VDC Voltmeter digital type shall be provided to check the Field Interrogation voltage.

Exhaust Fans with louvers & filters shall be provided on door's (front & Rear) upper side to remove hot air in all consoles, control desk and panels.

Fire/Smoke detectors shall be provided inside the Control room mounted system/control cabinets.

UPS, 24 V DC & non UPS's Feeder failure/ healthy indication shall be provided in each cabinet & remote indication shall be hooked up to DDCMIS/ PLC/annunciation & suitably grouped.

All the panels shall be equipped with Anti vibration pad of min. 15 mm size. Cable gland plate thickness shall be 3 mm.

Doors shall be provided with neoprene/polyurethane gasket only.

All the cable entries shall be at the bottom of electronic cubicles/control panels.

Protection class of panels shall be as specified at Vol. V, chapter 2.

6.04.01 Operator Control Desk

6.04.01.1 In CCR, Operator work station consoles/desk shall be of granite top of curved nature with powder coated frame. OWS consoles shall be provided with the facility for locating the CPU, document etc with all required utilities.

Unit In charge desk/consoles shall be of granite top of curved nature with powder coated frame. OWS consoles shall be provided with the facility for locating the CPU, document etc with all required utilities.

Station In charge desk/consoles shall be of granite top of curved nature with powder coated frame. OWS consoles shall be provided with the facility for locating the CPU, document etc with all required utilities.

6.04.01.2 Engineer work station and all other consoles/desk shall be ergonomically designed industrial grade type with swivel chairs for use at the various Programming stations and all other plant locations. All the equipment like Programmers stations, P C's, various peripherals & similar devices shall be complete with desks and they shall be of industrial grade stands and other mounting accessories and the same shall be completely erected & commissioned by the bidder. Details for other operating and engineering stations shall be as below:

- i. Operator Control desk shall be free standing table top type with doors at the back and shall be constructed of 3 mm thick CRCA steel plates. It shall have concealed cable & wire way management system. The top surface of control



desk shall be 30mm thick with the top 12mm of acrylic solid surface and the remaining 18mm of laminated medium density fibre board. Control desk shall consist of vertical, horizontal and base supports with their coverings for work surface, keyboard trays, Mouse pads, Monitor shelf and concealed cable and wire way management, perforated trays with covers in both horizontal & vertical directions.

- ii. To achieve durable & water resistant finish, a sheet of "plastic PVC membrane" on the surface of control desks shall be provided. Final paint finish with proper smoothing is to be ensured. Final finish of CD should be in line with relevant International standards. For more durability, the membrane sheet of the Control desk should extend 200 mm more into the underside of the desk. The cabling / wiring between OWS & CPU's, power supply cables etc. shall be aesthetically routed and concealed from view.
- iii. All the control desk shall be equipped with Anti vibration pad of min. 15 mm size. Cable gland plate thickness shall be 3 mm.
- iv. Doors shall be provided with neoprene/polyurethane gasket only.

6.05.00 SURFACE PREPARATION AND PAINTING

All panel exterior steel surfaces shall be ground smooth, and painted as specified below:

Suitable filler shall be applied to all pits, blemishes and voids in the surfaces. The filler shall be sand blasted so that surfaces are level and flat, corners are smooth and even. Exposed raw metal edges shall be ground burr free. The entire panel surface shall be sand blasted to remove rust and scale and all other residue due to the fabrication operation. Oil grease and salts etc. shall be removed from the panels by one or more solvent cleaning methods. Alternatively 7 tank process shall be followed.

Two spray coats of inhibitive epoxy primer – surface shall be applied to all exterior and interior surfaces, each coat of primer surfacer shall be of dry film thickness of 1.5 mil. A minimum of two spray coats of final finish colour (Catalysed epoxy finish) shall be applied to all surfaces of dry film thickness 2.0 mil. The finish colours for exterior and interior surfaces shall conform to the following shades:

- a) Exterior - RAL 7032/RAL 7035.
- b) Interior - Glossy white two coats/RAL 7035 with fire resistant paint

One uniform colour shade as finalized shall be applicable for complete plant.

Paint films, which show saggs, checks, blisters, teardrops, fat edges or other painting imperfections, shall not be acceptable and if any such defects appear, they shall be repaired by and at the expenses of the Bidder.

6.06.00 PANEL WIRING

Interconnecting wiring shall be provided between all electrical devices mounted in the panels, and between the devices and terminal blocks if the devices are to be connected



to equipment outside the panels by cabling and through pre-fabricated plug in cables. All alarm contacts located within a panel shall be wired to terminal blocks. Thermocouple and other special circuits shall be field wires direct to instrument terminal blocks without the use of panel wiring.

All control and instrument wiring used within the panels shall conform to NEC and NEMA standards and shall be factory installed and tested at the works of a qualified manufacturer. All interior wiring shall be installed neatly and carefully, and shall be terminated at suitable terminal blocks. Sufficient clearance shall be provided for all control and instrumentation leads, and all incoming and outgoing leads shall be connected to terminal blocks suitably located for connecting external circuits.

All panel wiring shall have appropriate ferruling for clear identification. Interior wiring shall be so arranged that the external connections can be made with only one wire per terminal point. Any common connections shall be made internal side of the terminal blocks. Common connections shall be limited to two wires per terminal. Instrumentation cable shield wires shall be connected to separate terminal at the terminal block. Signal circuit shields shall be grounded separately.

All internal wiring (except low level instrument wiring) shall be National Electric Code Type SIS, Polymeric/Elastomeric insulated, tinned copper stranded conductor, switchboard wire, or owner approved equal.

Panel wiring shall have a flame resistant insulation with adequately sized 650/1100 V grade tinned copper stranded conductor based on current carrying capacities as etc forth by the National Electric Code.

Wire sizes shall be as specified herein and suitable for intended applications.

Wiring to door mounted devices shall be provided with (49 strand minimum) adequate loop lengths of hinge wire so that multiple door openings will not cause fatigue braking of the conductor.

Wiring shall be arranged to enable instruments or devices to be removed and/or serviced without unduly disturbing the wiring. No wire shall be routed cross the face or rear of any device in a manner, which will impede the opening of covers or obstruct access to leads, terminals or devices.

Panel wires shall be identified with wire number and each termination by means of Action craft products split sleeve or Borden Chemical Co. indelible tubing markers or owner approved equal. Corrections and modifications of all panel wiring shall be Bidder's sole responsibility. Any corrections/modifications required at site for successful commissioning shall be done by the Bidder without any additional costs. Terminal lugs furnished must be of the compression, insulated sleeve, half ring tongue type. Open-ended terminal lugs will not be accepted. Wires shall not be looped around the terminal screws or studs.

Wires shall not be tapped or spliced between terminal points.

Panels, cabinets, consoles/desks will be provided with removable, gasketed cable gland plates and cable glands, for all floor slots used for cable entrance. Split type grommets shall be used for prefab cables.



Internal wiring in factory prewired electronic systems cabinets may be installed according to the Bidder's standard as to wire size, insulation, and method of termination on internal equipment except that insulation for all wiring power supply wiring, and interconnecting cables between devices shall pass the following tests.

- a) Flammability test IEEE 383/1974
- b) When tested under UITPP test method or ASTM 2893/77 light transmittance of 80%
- c) When tested under IEC 754 -1 maximum acid gas generation shall be 2% by weight
- d) Oxygen index not less than 30 as per ASTM D 2863.

All terminations for intra panel wiring inter panel cabling and connecting the Bidders panels, PB stations, control stations etc. shall be with cage clamp Screwed less connections. Soldered connections are not acceptable. All field side or external input connections shall also preferably of Cage clamp/Spring Clamp/ Screwed less connection.

Conductor Clamping shall also confirm to Standard IEC – 60947-1 & IEC-60947-7-1.

Identification of conductors may be done by insulation colour coding identified on drawings or by printed wiring lists. Terminal blocks for connection of external circuits in to factory prewired electronic system cabinets shall meet all the requirements as described elsewhere in the specification. For all multicore cables, the outer sheath shall satisfy the properties identified above. However, for panel wiring, the wiring insulation shall also satisfy the properties identified above. The internal wiring shall be done in coloured wiring.

6.06.01

Following Wire size shall be utilized for internal wiring:

- | | | | |
|------|---|---|------------|
| a. | Current (4-20 mA)
Low voltage signals
(AI/AO & DI signals) | : | 0.75 sq.mm |
| b. | DO signals, Ammeter/
voltmeter circuit, control
switches, indicator, recorder | : | 1.5 sq.mm |
| c. | Internal Illumination | : | 2.5 sq.mm |
| d. | Size of Power supply cables shall be as below:- | | |
| i. | 1 to 16 Amp. | - | 2.5 sq. mm |
| ii. | 17 to 20 Amp. | - | 4 sq. mm |
| iii. | 21 to 32 Amp. | - | 6 sq. mm |
| iv. | 33 to 40 Amp. | - | 10 sq. mm. |
| v. | 41 to 60 Amp. | - | 16 sq. mm |
| vi. | Power earth | - | 4 sq. mm |

6.07.00

INSTRUMENTS MOUNTING



2 x 660 MW ENNORE SEZ Supercritical Thermal Power
Project at Ash Dyke of NCTPS
Spec. No. CE/C/P&E/EE/E/OT.No.03/2013-14



6.07.01 Instruments and relays mounted on the panels shall be easily accessible for repair and replacement without disturbing other equipment their connected wiring. No special tools shall be needed for the purpose.

6.08.00 PANEL ILLUMINATION

Panels shall be provided with LED based illuminating lamps with door switch and six (6) point 6/ 16A, 240V A C uni versal t ype po wer so ckets with sw itch f or m aintenance purposes. These switches shall be with quick make and break mechanism. 100 % spare LED l amps shall be p rovided with each panel , t hese a re i n a d d i t i o n a l t o m a n d a t o r y spares.

6.09.00 FUSE BLOCKS

Where fuse blocks rated 30 amp. 250 Volts are required by the specifications or the manufacturer's design, they shall be modular type with bakelite frame and reinforced retaining clips. Blocks shall be class H.2 pole, screw terminal fuse blocks. Blocks for other current and voltage ratings shall be similar in construction.

6.10.00 FUSES & MCB

All fuses shall be fast acting semiconductor types for AC supply and compatible to the UPS fuses. For al l D C P owered dev ices, si milarly t he f uses shall be f ast ac ting compatible to DCDB fuse provisions. All the AC power supplies shall be provided with the protection of Fast acting semi conductor fuses & 2 P thermomagnetic type MCB. Make of Fuses shall be GE or Siemens. For all the DC power supply circuits, electronic type DC MCB shall be use d only. Make of DC MCB shall be S iemens, P hoenix contacts, Murr, Weidmuller, or Lutze.

50 % spare fuses shall be provided with each panel, these are in additional to mandatory spares.

6.11.00 MOULDED CASE CIRCUIT BREAKERS

Moulded ca se ci rcuit br eakers used i n e quipment co vered under t hese sp ecifications shall have not less than 5000 amp. Interrupting capacity at 220 Volts DC 10,000 Amp. Symmetrical interrupting capacity at 240 Volts AC. MCCB shall be provided at each main feeder line like ACDB & DCDB main feeders, PLC main feeder, control panels, UPS circuits etc.

6.12.00 GROUNDING

All panels and cabinets shall be provided with a continuous bare copper ground bus of minimum 6 mm x 25/50 mm cross section. The ground bus shall be bolted to the panel structure and effectively ground the entire structure. Each Ground bus shall have provision at each end for co nnection o f ground l eaks (6 m m x 50 m m G I F l a t s) by suitable bolting. All system cabinets shall be brought to a common system ground by the bidder. Electronic earthing resistance shall be < 0.5 ohms.

Each circuit requiring grounding shall be individually and directly connected to the panel ground bus by ring tongue type compression lugs. For electronic system cabinets the system ground bus shall be insulated from the cabinet enclosure and shall be separately



connected to the system ground. All system cabinets shall be brought to a common system ground by the bidder.

The Bidder shall furnish his recommendations regarding grounding requirements for all equipment/systems and shall specifically indicate the deviations if any from the above requirements as a part of his proposal.

6.13.00 TERMINAL BLOCKS

For all inputs to the system emanating from the field or other systems, the bidder shall furnish terminals suitable for correct size of field cables.

6.13.01 All outputs going to MCC/SWGR terminal blocks, shall be rated 600 volts minimum and shall have strap screw less terminals suitable for connection of wires with ring tongue type lugs. Standard terminal blocks shall be screw less cage clamps type. Terminal blocks shall be approximately sized for larger wire size of higher voltage insulated incoming conductors as necessary. All the TBs used shall be 6.6 polyimide to withstand corrosion and the metallic portion shall be coated against rust /corrosion. All metal parts should be non –ferrous in nature.

6.13.02 Terminal blocks shall be provided with white marking strips and re permitted by the safety codes and standards shall be without covers.

6.13.03 Fuses shall not be mounted on terminal blocks. Neither step type terminal blocks nor angle mounting of terminal blocks will be acceptable.

6.13.04 At least 20 per cent spare unused fully wired terminals shall be provided on each terminal block for circuit modifications and for termination of all conductors in a multi-conductor control cable with each panel, enclosure, cubicle, SOV Boxes etc.

6.14.00 NAME PLATES AND LABELS

Name plates of adequate size shall be provided for each panel on front and rear of the panel. Instruments/other accessories mounted inside the panels shall have identification marking clearly visible from inside.

Devices to be mounted on the panels shall also be labeled on the panels shall also be labeled on the outside of the panel. Name plates shall be of polyamide sheets with black letters on white background. Name plates shall be attached to the boards by means of stainless steel panhead screws. Fuses provided for protection of various boxes shall be accessible for replacement. Fuse boxes shall be provided with circuit label and fuse rated current and voltage.

Markings/Labels

All markers/labels shall be made of halogen & silicon free polyamide material with inflammability class V2 as per UL 94, ensuring scratch proof printing with the use of environment friendly solvent free ink & latest BLUEMARK UV technology so as to comply the WIPE RESISTANCE according to DIN EN 61010-1/VDE 0411-1.



**DRIVE
CONTROL
PHILOSOPHY
FOR
ANALOG
&
BINARY
DRIVES**

DCS INTERFACE FOR BIDIRECTIONAL DRIVE(WITH INTEGRAL STARTER)

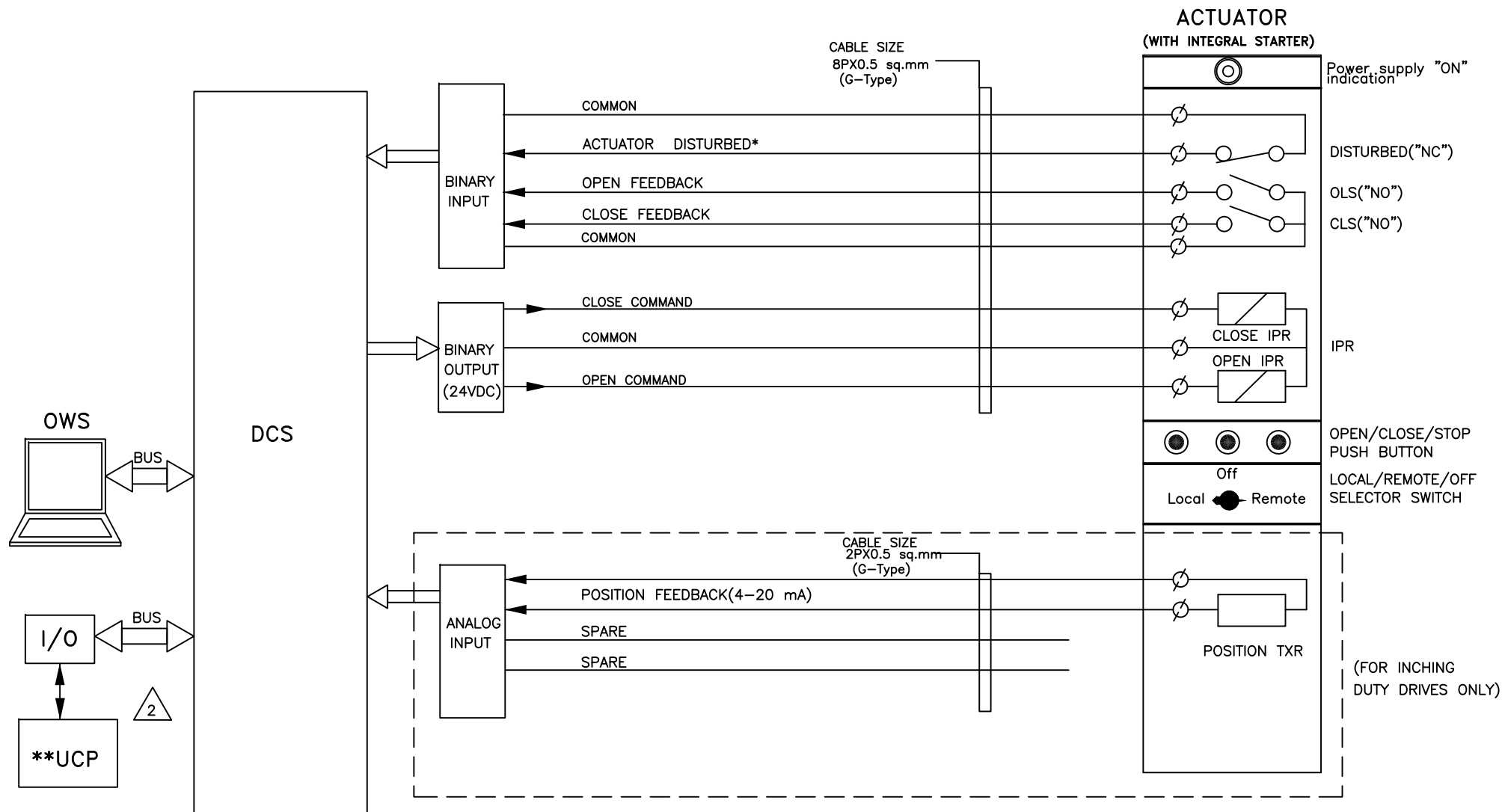

NOTE:

* DISTURBED= Loss of Power supply (1 Phase/3 Phase)/
 Loss of control supply/ Motor thermostat trip/
 Thermal over load/Torque open/close cutoff
 Local/Off/Remote Sel. switch in local or off mode/
 Stop PB optd.



** AS APPLICABLE.



PROJECT: 2X660 MW ENNORE SEZ STPP

TITLE DDCMIS INTERFACE FOR BIDIRECTIONAL DRIVE

DRG.NO.	PE-DM-412-145-I002
DATE	01.05.2015
REV.NO.	02
SHT	7 OF 11

DCS INTERFACE FOR UNIDIRECTIONAL LT DRIVE

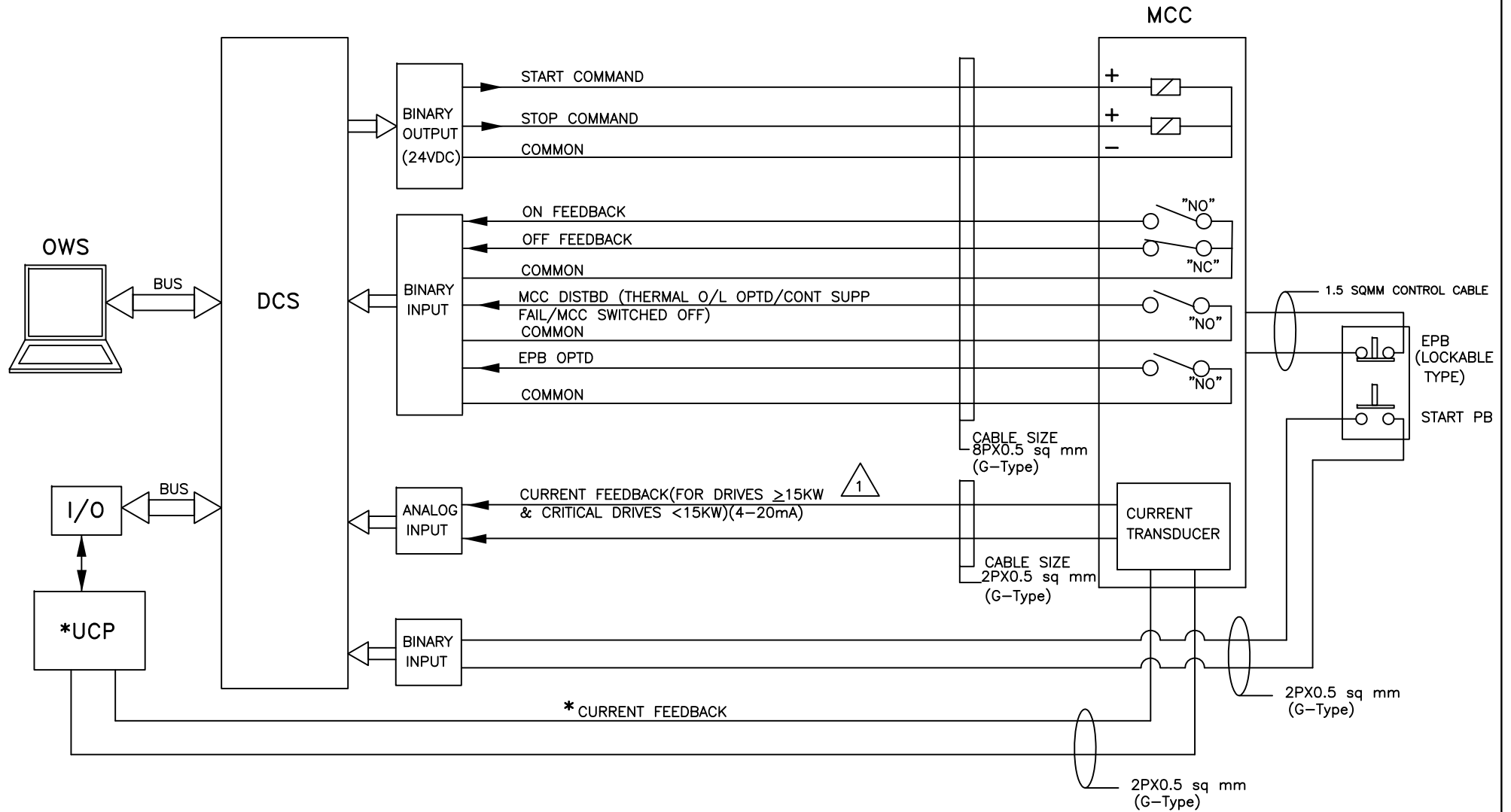

NOTE:

*WHEREVER APPLICABLE



PROJECT: 2X660 MW ENNORE SEZ STPP

TITLE DDCMIS INTERFACE FOR UNIDIRECTIONAL LT DRIVE

DRG.NO.	PE-DM-412-145-1002
DATE	01.05.2015
REV.NO.	02
SHT	8 OF 11

DCS INTERFACE FOR SOLENOID DRIVE (220V DC/ 24V DC / 240V AC UPS)

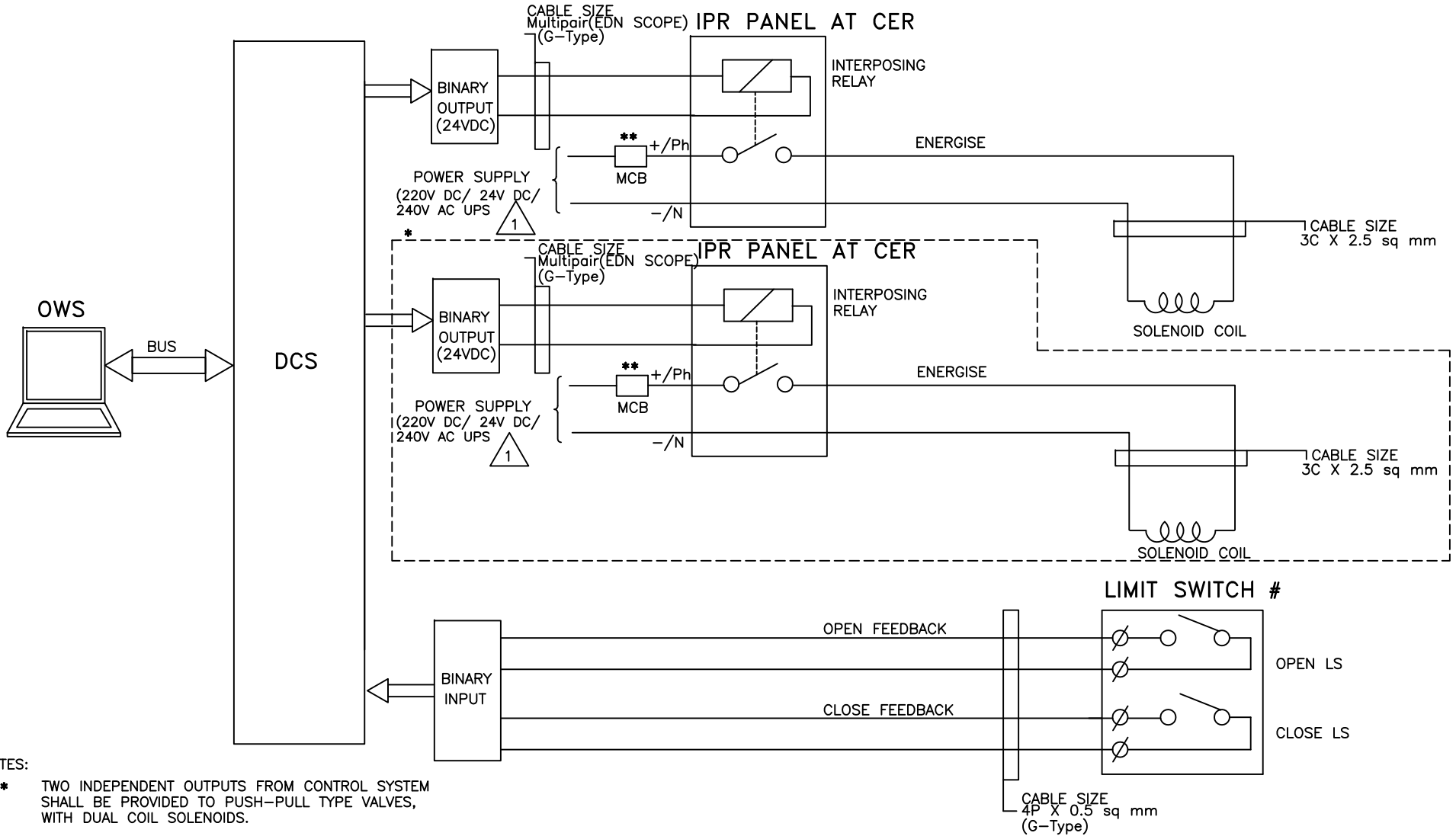

- NOTES:
- * TWO INDEPENDENT OUTPUTS FROM CONTROL SYSTEM SHALL BE PROVIDED TO PUSH-PULL TYPE VALVES, WITH DUAL COIL SOLENOIDS.
 - ** MCB SHALL BE PROVIDED FOR EACH SOLENOID

- # FOR ON/OFF TYPE, SOLENOID ACTUATED VALVE. RELAY CONTACTS SHALL BE WIRED AS FEEDBACK WHEREVER LIMIT SWITCH FEEDBACKS ARE NOT AVAILABLE. 1 CONTACT FOR SINGLE COIL & 2 CONTACT FOR DUAL COIL (OPEN LIMIT SWITCH & CLOSED LIMIT SWITCH).
- *** BHEL WILL TAKE CARE OF DE-ENERGISE TO TRIP PHILOSOPHY FOR FAIL SAFE CONTROL SYSTEM (WHEREVER REQUIRED)

	PROJECT: 2X660 MW ENNORE SEZ STPP		DRG.NO. PE-DM-412-145-1002
	TITLE DDCMIS INTERFACE FOR SOLENOID DRIVE		DATE 01.05.2015
			REV.NO. 02
			SHT 9 OF 11

DCS INTERFACE FOR HT/LT UNIDIRECTIONAL DRIVES(BREAKER OPERATED)

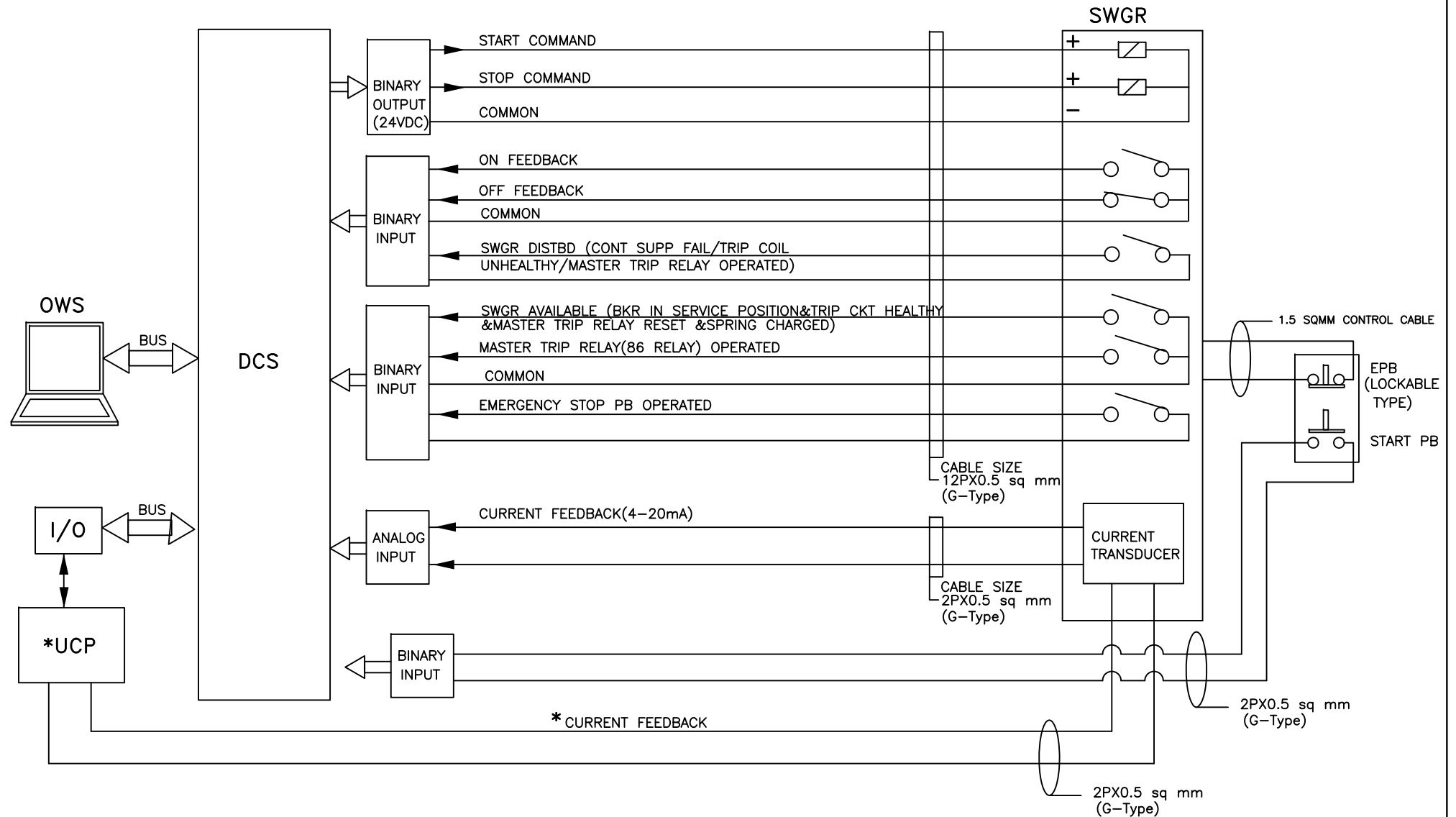

NOTE:

- * WHEREVER APPLICABLE
- # VIBRATION, WINDING & BEARING SIGNALS SHALL BE INTERFACED WITH DDCMIS AND INCLUDED IN EDN'S DOCUMENT.

1



PROJECT: 2X660 MW ENNORE SEZ STPP

TITLE DDCMIS INTERFACE FOR UNIDIRECTIONAL HT DRIVE

DRG.NO.	PE-DM-412-145-1002
DATE	01.05.2015
REV.NO.	02
SHT	10 OF 11

DCS INTERFACE FOR ANALOG DRIVE (WITH SMART POSITIONER)

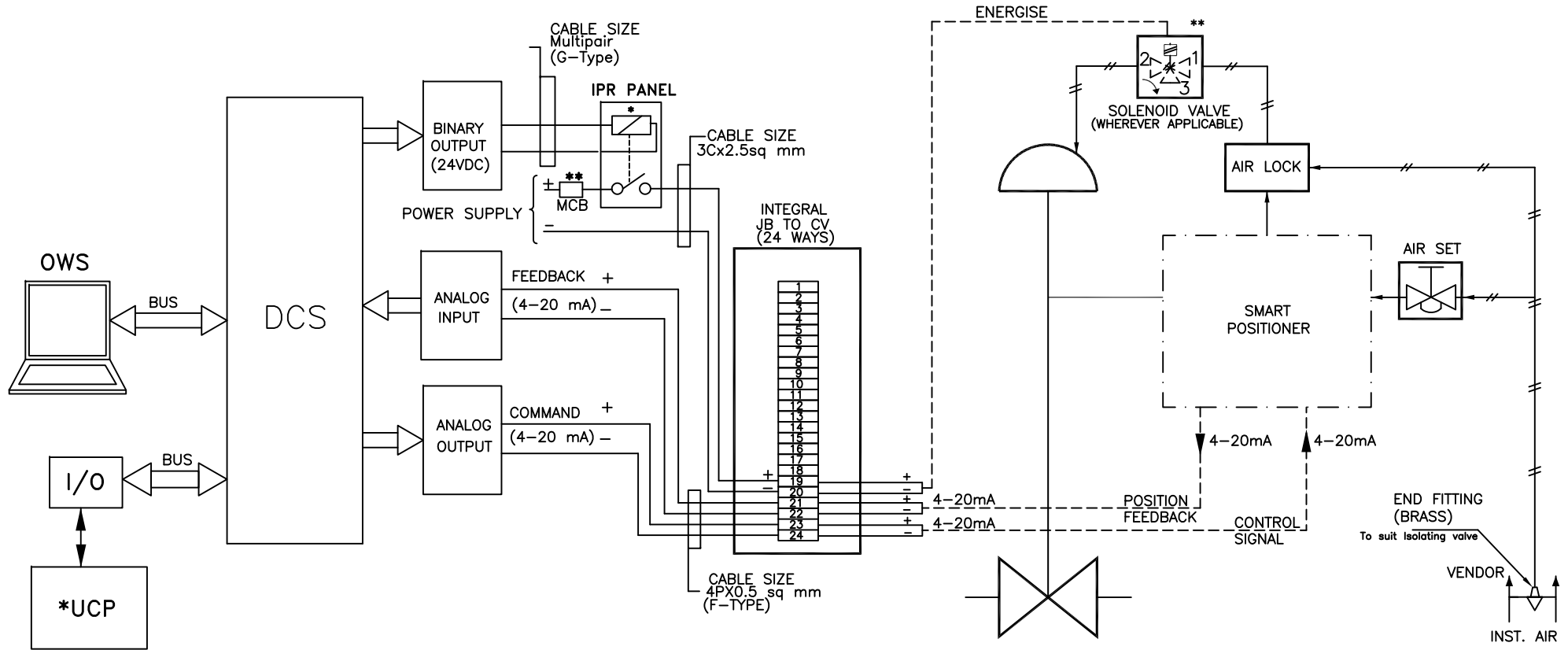

NOTES:

** APPLICABLE TO VALVES WHERE PROTECTION OPEN/CLOSE ACTION FOR CONTROL DEMAND OVERRIDING IS REQUIRED.



PROJECT: 2X660 MW ENNORE SEZ STPP

TITLE TYPICAL HOOK-UP DIAGRAM
ANALOG DRIVE (WITH SMART POSITIONER)

DRG.NO.	PE-DM-412-145-1002
DATE	01.05.2015
REV.NO.	02
SHT	11 OF 11

**APPLICABLE
CODES
&
STANDARDS**

1.08.00 CODES AND STANDARDS

1.08.01 All equipments, system and service covered under this specification shall comply with the requirements of the latest statutes regulations and safety codes as applicable in the locality where the equipments/systems will be installed. The Bidder shall fully acquaint himself with these requirements and shall ensure compliance with them.

The equipments, systems and services furnished as per this specification shall conform to the codes and standards mentioned in Cl. no. 1.08.02 of this Section. However in the event of any conflict between the requirements of two standards or between the requirements of any standard and this specification, the more stringent requirements shall apply unless confirmed otherwise by the Owner in writing. The decision of the Owner shall be final and binding in all such cases.

The Bidder's scope of supply shall include some items such as thermowells, and other in-line devices for main steam, hot reheat, cold reheat, feed water system falling under the purview of Indian Boiler Regulation (IBR) Act. It shall be the responsibility of the Bidder to obtain the necessary approval of the concerned Inspecting Authority/Chief Inspector of Boilers for the design and design calculations and manufacturing and erection procedures as called for under the IBR act for all items requiring such certifications.

The requirements of statutory authorities (e.g. MOEF, Inspectors of factories, IBR, TAC, BEE, CPCB/TNPCB etc) with regards to various plants areas like Main plant, Fuel oil plant/system, Chlorination Plant, Fire Fighting system, Emission Measurement, Ambient Air Monitoring system etc. shall be complied, even if not actually spelt out.

1.08.02 Reference Codes and Standards

The design, manufacture, inspection, testing, site calibration and installation of all equipment and systems covered under this specification shall conform to the latest editions of codes and standards mentioned below and all other applicable ANSI,



ASME, IEEE, NEC, NEMA, ISA, DIN, VDE, NFPA, IEC, EIA, TIA and Indian Standards and their equivalents. Bidder to note that in no case, OEM/manufacturers own standards shall be accepted.

1.08.02.01 Temperature Measurement

1. Performance Test Code for temperature measurement ASME PTC 19.3 (1974 – R 1998)
2. Temperature measurement - Thermocouples ANSI-MC 96.1 – 1982, IEC 584
3. Temperature measurement by electrical resistance thermometers - IS-2806.
4. Thermometer-element-platinum resistance-IS-2848, IEC 751/DIN 43760
5. RTD Design Code – DIN EN 60751:1996, BS EN 60751 : 2008
6. Thermowell Design Code – ASME PTC 19.3 TW – 2010

1.08.02.02 Pressure Measurement

1. Performance Test Code for pressure measurement - ASME PTC 19.2 (2010)
2. Bourdon tube pressure and vacuum gauges - IS 3624, IS 3602, ASME B 40.1

1.08.02.03 Electronic measuring Instruments & Control hardware

1. Automatic null balancing electrical measuring instruments - ANSI C 39.4 (Rev. 1973), IS 9319
2. Safety requirements for electrical and electronic measuring and controlling instrumentation - ANSI C 39.5 - 1974.
3. Compatibility of analog signals for electronic industrial process instruments - ISA-S 50.1:ANSI MC 12.1 - 1975.
4. Dynamic response testing of process control instrumentation - ANSI MC 4.1 (1975): ISA-S26 (1968).
5. Surge withstand capability (SWC) tests - ANSI C 37.90A (1974) IEEE Std. 472 (1974). IEC – 255.4.
6. Printed circuit boards - IPC TM-650, IEC 326 C
7. General requirements and tests for printed wiring boards - IS 7405 (Part-I) - 1973
8. Edge socket connectors - IEC 130-11.
9. Requirements and methods of testing of wire wrap terminations DIN 41611 Part-2.
10. Dimensions of attachment plugs & receptacles ANSI C73-1973.
11. Direct acting Electrical Indicating Instruments: IS-1248-1968.

1.08.02.04 Instrument Switches and Contacts

1. Contact rating - AC services NEMA ICS Part-2 125, A600
2. Contact rating - DC services NEMA ICS Part-2-125, N600.

1.08.02.05 DDCMIS & other Control System

1. Application of Safety Instrumented System – ANSI/ISA 84.01 1996
2. Functional Safety - Safety Instrumented System for Process Sector – IEC – 61151



3. IEEE Application Guide for Distributed Digital Control Monitoring for Power Plant – IEEE 1046
4. Fossil Fuel Power Plant Steam Turbine Bypass System – ANSI/ISA – 77.13.01
5. Human System Interface Design Review Guide lines – NUREG – 700
6. Annunciation Sequence and Specification – ANSI/ISA 18.1
7. “IEEE 1050, IEEE guide for Instrumentation & control system grounding in generating station”,
8. ANSI/ISA-77.44.01-2007 - Fossil Fuel Power Plant - Steam Temperature Controls
9. ANSI/ISA-RP77.60.05-2001 (R2007) - Fossil Fuel Power Plant Human-Machine Interface: Task Analysis
10. ANSI/ISA-77.42.01-1999 (R2006) - Fossil Fuel Power Plant Feedwater Control System – Drum-Type
11. ANSI/ISA-77.20-1993 (R2005) - Fossil Fuel Power Plant Simulators - Functional Requirements
12. ANSI/ISA-77.41.01-2005 - Fossil Fuel Power Plant Boiler Combustion Controls
13. ANSI/ISA-RP77.60.02-2000 (R2005) - Fossil Fuel Power Plant Human-Machine Interface: Alarms
14. ANSI/ISA-77.70-1994 (R2005) - Fossil Fuel Power Plant Instrument Piping Installation
15. ANSI/ISA-TR77.60.04-1996 (R2004) - Fossil Fuel Power Plant Human-Machine Interface-Electronic Screen Displays
16. ANSI/ISA-77.43.01-1994 (R2002) - Fossil Fuel Power Plant Unit/Plant Demand Development-Drum Type
17. ANSI/ISA-77.13.01-1999 - Fossil Fuel Power Plant Steam Turbine Bypass System

1.08.02.06 Electronic Cards, Subassemblies and Components

a) Unpackaged

- | | | | |
|------|----------------|---|-------------|
| i) | Vibration | : | IEC-68.2.6 |
| ii) | Shock | : | IEC-68.2.27 |
| iii) | Drop & Topple: | : | IEC-68.2.31 |

b) Packaged

Vibration, Drop & Static Compression - NSTA

c) Electromagnetic Compatibility

- | | | | |
|------|--------------------------------|---|-------------------|
| i) | Electrical Fast Transient | : | IEC-801.4 |
| ii) | Surge Withstand | : | IEC-255.4 |
| iii) | Radiated Electromagnetic Field | : | IEC-801.3 |
| iv) | Electrostatic Discharge | : | IEC-801.2 |
| v) | Electromagnetic Emission | : | VDE 0871, Class B |

1.08.02.07 UPS System/DC control power supply system:

1. Practices and requirements for semiconductor power rectifiers - ANSI C34.2-1973.



2 x 660 MW ENnore SEZ Supercritical Thermal Power
Project at Ash Dyke of NCTPS
Spec. No. CE/C/P&E/EE/E/OT.No.03/2013-14



2. Relays and relay systems associated with electrical power apparatus - IEEE Std. 3.13, ANSI C 3790-1983.
3. Surge withstand capability tests - ANSI C37.90a-1974. IEEE Std. 472 - 1974
4. Recommended practice for sizing large lead storage batteries for generating stations & substations - IEEE-485.
5. Performance testing of UPS - IEC 146.
6. IEC 62040 – General & Safety requirement of UPS.
7. IEC 62040-2 - UPS – EMC Requirement.
8. IEC 62040-3 - UPS – Method of specifying the performance and test requirement.
9. IEC 60269-2 – Main Supply Fuse.
10. IEC 60947 – MCCB.
11. IEC/EN 60623– BATTERIES.
IEEE485/IEEE1115
IS : 10918, IS : 1069
12. IEC 60146 - For DC system.

1.08.02.08 Control Valves

1. Control Valve sizing - Incompressible fluids - ISA S39.2 - 1972.
2. Control valve sizing - Compressible fluids - ISA S39.3 - 1973, ISA S39.4 - 1974.
3. Face to face dimensions of control valves - ANSI B16.10
 - 1) ISA Hand book of control valves - ISBN B1047-087664-234-2.
 - 2) Valves - flanged, threaded and welding end : ANSI B 16.34(2009)
 - 3) Casting : ASTM A 216 / A 351 (2008)
 - 4) Welded end connection : As per ASME boiler and pressure vessel code / ANSI.B 16.34(2009), B16.25 (2009), B 16.11(2009).
 - 5) Defect removal: ANSI B 16.34 2009.
 - 6) Cleaning : ASTM A 380 2006.
 - 7) CV test : As per ISA procedure S 75.02 (2008).
 - 8) Control Valve seat leakage : ANSI/FCI 70.2

1.08.02.09 Enclosures

1. Types of enclosures - NEMA Std. ICS-6-110.15 through 110.22 (Type 4 to 13).
2. Racks, panels, and associated equipment - EIA: RS-310-B (ANSI C83.9 - 1972)
3. Protection Class for Enclosure, Cabinets, Control Panels and Desks - IS-13947-1962.

1.08.02.10 Apparatus, enclosures and installation practices in hazardous areas

1. Classification of hazardous area - NFPA Art. 500, Vol.70-1984.
2. Electrical Instruments in hazardous dust locations - ISA-RP 12.11
3. Intrinsically safe apparatus - NFPA Art.493 Vol.4.1978
4. Purged and pressurized enclosure for electrical equipment in hazardous location - NFPA Art. 496 1982.

1.08.02.11 Sampling System



1. Stainless steel material of tubing and valves for sampling system - ASTM A269-82 Gr TP316.
2. Submerged helical coil heat exchangers for sample coolers ASTM D 11-98.
3. Water and Steam in power cycle - ASME PTC 19.11(2008).
4. Standard methods of sampling system - ASTM D 1066-69.

1.08.02.12 Annunciators

1. Specifications and guides for the use of general purpose annunciators - ISA RP 18.1-1979.
2. Surge withstand capability tests - ANSI C.37.90a - 1974 and IEEE std. 472-1974

1.08.02.13 Interlocks, Protections

1. Relays and relay system associated with electric power apparatus - IEEE std.3.13.
2. Surge withstand capability tests - ANSI C.37.90a - 1974 and IEEE Std. 472 - 1974.
3. General requirements & tests for switching devices for control and auxiliary circuits including contactor relays - IS-6875 (Part-I) 1973.
4. Turbine water damage prevention - ASME - TDP-1980.
5. Boiler safety interlocks - NFPA Section 85B, 85D, 85E, 85F,85G.

1.08.02.14 Process Connection and Piping:

1. Codes for pressure piping power piping ANSI B31.1
2. Seamless carbon steel pipe ASTM A-106.
3. Forged and Rolled Alloy steel pipe flanges, forged fittings, valves and parts - ASTM A-182.
4. Material for socket welded fittings - ASTM A-105.
5. Seamless ferrite alloy steel pipe - ASTM A-335.
6. Pipe fittings of wrought carbon steel and alloy steel - ASTM A-234.
7. Composition bronze or metal castings - ASTM B-62.
8. Seamless copper tube, bright annealed ASTM B-168.
9. Seamless copper tube - ASTM B-75.
10. Dimensions of fittings - ANSI B-16.11
11. Valves flanged and butt welding ends - ANSI B16.34.
12. Nomenclature for Instrument tube fittings ISA-RP-42.1 - 1982.

1.08.02.15 Instrument Tubing

1. Seamless carbon steel pipe - ASTM - A106.
2. Material for socket weld fittings - ASTM - A105.
3. Dimensions of fittings - ANSI B16.11
4. Code for pressure piping, welding, hydrostatic testing - ANSI B31.1.

1.08.02.16 Cables

1. Thermocouple extension wires/cables - ANSI C 96.1 - 1982.
2. Colour coding of single or multi-pair cables – VDE 0815



3. Guide for design and installation of cable systems in power generating stations (insulation, jacket materials) - IEEE Std. 422 - 1977.
4. Requirements of vertical tray flame test - IEEE 383 - 1974.
5. Standard specification for tinned soft or annealed copper wire for electrical purpose - ASTM B-33 - 81.
6. Oxygen index and temperature index test - ASTM D-2863.
7. Smoke generation test - ASTM D-2843 and ASTM E-662.
8. Acid gas generation test - IEC-754-1.
9. Swedish chimney test - SEN - 4241475 (F3)
10. Instrumentation cables and internal wiring I S-1554 (Part-I, 1976) and I S-5831(1984).
11. Standard for Control, Thermocouple Extension and Instrumentation cable - NEMA WC 57-2004 ICEA S-73-532, Rev. 2, 2004)□
12. PVC insulated (heavy duty) Electric cables for working voltages upto and including 1100V - IS:1554 (Part-I)
13. Conductors for insulated electric cables and flexible cords. - IS:8130
14. PVC insulation and sheath of electric cables - IS:5831
15. Mild steel wires, strips and tapes top armoring cables - IS:3975
16. Water Immersion Test - VDE 0815
17. Drums for electric cables - IS : 1048

1.08.02.17 Cable Trays, Conduits

1. Guide for the design and installation of cable systems in power generating station (cable trays, support systems, conduits) - IEEE Std. 422, NEMA VE-1, NFPA-70-1984.
2. Guide for the design and installation of cable systems in power generating station (Cable trays, support systems, conduits) Test Standards, NEMA VE-1 - 1979.
3. Galvanising of Carbon steel cable trays - ASTM A-386-78.

1.08.02.18 Flow measurement

1. ASME Performance Test Code PTC-19.5 (2004), ISA RP3.2
2. BS 1042
3. ISO 5167

1.08.02.19 Surge Protection System

1. Surge withstand capability tests - ANSI C37.90a-1974. IEEE Std. 472 – 1974
2. IEC 61643-1:1998-02 and E DIN VDE 0675 part 6:1996-03/A2: 1996-10
3. IEC 61643-21:2000-09 and E VDE 0845 part 3-1:1999-07

1.08.02.20 Digital Video Recording & Management System (DVRMS)

1. ISO 9001 (2000)
2. ISO/IEC15504 Level3 or higher (SPICE 2.0 Software Process Improvement and Capability Determination)



3. SEICMM Level 3 or higher (American Software Engineering Institute - Capability Maturity Model)

Where:

- i) IEEE - Institute of Electrical and Electronics Engineers.
- ii) ISA - Instrument, Systems and Automation Society
- iii) NEMA - National Electrical Manufacturers Association
- iv) ANSI - American National Standards Institute
- v) NFPA - National Fire Protection Association
- vi) ASME - American Society of Mechanical Engineers
- vii) IS - Indian Standards
- viii) IEC - International Electro-technical Commission
- ix) ASTM - American Society for Testing Materials
- x) EIA - Electronic Industries Association
- xi) DIN - Deutsche Institute Normale
- xii) TIA – Telecommunication Industries Association



2 x 660 MW ENNORE SEZ Supercritical Thermal Power
Project at Ash Dyke of NCTPS
Spec. No. CE/C/P&E/EE/E/OT.No.03/2013-14





TITLE : TECHNICAL SPECIFICATION
FOR
SELF CLEANING STRAINERS

SPEC. NO. PE-TS- 412-165-N003

VOLUME : IIB

SECTION : C

REV. NO. 0

DATE :
16.06.15

SHEET 1 of 1

SECTION – D

STANDARD TECHNICAL SPECIFICATION

SECTION D1 : SELF CLEANING STRAINER (MECHANICAL)

SECTION D2 : ELECTRICAL SYSTEMS

SECTION D3 : C&I SYSTEM



TITLE : TECHNICAL SPECIFICATION
FOR
SELF CLEANING STRAINERS

SPEC. NO. PE-TS- 412-165-N003

VOLUME : IIB

SECTION : C

REV. NO. 0

DATE :
16.06.15

SHEET 1 of 1

SECTION D1
STANDARD TECHNICAL SPECIFICATION
FOR
SELF CLEANING STRAINERS

	TITLE :	SPEC. NO. PE-TS- 999-165-N002
306262 (SHEET P/M)	STANDARD TECHNICAL SPECIFICATION	VOLUME : II B
	SELF - CLEANING FILTERS	SECTION : D
		REV. NO. 0 DATE : 02.12.2009
		SHEET 1 OF 10

1.00.00 **GENERAL**

This specification covers the Design, Performance and Operational Requirements, Constructional Features, Manufacture, Assembly. Inspection and Testing at the Manufacturer's and/or his Sub-contractor's works and Painting for delivery of Self-cleaning filter (Backwash Type) complete with all accessories as specified hereinafter.

2.00.00 **CODES AND STANDARDS**

2.01.00 The design, materials manufacture, inspection and testing of the self-cleaning filter complete with all accessories, shall comply with the requirements of the latest revisions of the following appropriate codes and standards :

2.01.01 IS / BS / DIN / US Standards regarding pressure vessels, pipes, flanges and others as necessary.

2.01.02 IS / BS / DIN / ASTM Standards for materials specification and testing procedures.

2.01.03 IS / BS / DIN / AWWA Standards for valves and their testing.

2.02.00 In case of any conflict between the above codes / standards and this specification, the later shall prevail and in case of any further conflict in the matter, the interpretation of the specification by the Engineer shall be final and binding.

3.00.00 **DESIGN AND CONSTRUCTION**

3.01.00 **General Requirements**

3.01.01 Unless otherwise necessary manufacturer's standard and proven models of the self cleaning filter shall be supplied.

3.01.02 The self-cleaning filter shall be capable of safe, proper and continuous operation. Vibration, noise, mechanical stresses shall be kept within allowable limits specified by relevant codes / standards, In design due attention shall be given to ease of maintenance, repair and cleaning.

3.01.03 Suitable corrosion allowance shall be provided wherever necessary.

3.01.04 Unless otherwise specified in Data Sheet-A, the inlet and outlets of the filter shall be co-axial without any off set between the centre lines of inlet and outlet pipes.

3.02.00 **Performance Requirements**

The self-cleaning filter with all accessories shall be designed and guaranteed to meet the following requirements :-

3.02.01 The self - cleaning filter shall perform satisfactorily under the flow and pressure conditions specified in Data Sheet -A and shall be capable of housing the various forms of debris / sludge i.e., suspended particles / matter, mussels, grass, leaves,

	TITLE :	SPEC. NO. PE-TS- 999-165-N002
बि एच डी एल	STANDARD TECHNICAL SPECIFICATION	VOLUME : II B
	SELF - CLEANING FILTERS	SECTION : D
		REV. NO. 0 DATE : 02.12.2009
		SHEET 2 OF 10

wood pieces etc. The performance of the filter shall be continuous with minimum number of flushing / backwashing operations.

3.02.02 The self-cleaning filter shall be designed such that the pressure drop across the filter (i.e., between inlet and outlet connections) under clean conditions and partially (50%) choked conditions shall not be more than those specified in Data Sheet -A.

3.02.03 Unless otherwise specified in Data Sheet -A, debris discharge / wash water flow rate during flushing/back washing operation shall be limited to 10% of the total flow rate and flushing / backwashing operation shall be completed within a period of maximum three (3) minutes. The pressure drop across the debris filter during flushing/backwashing operation shall not be more than the pressure drop under partially (50%) choked condition.

3.02.04 The coarse particles and floating matter accumulating at the filter section/screen are flushed out of the system by the debris flushing / backwash unit such that the pressure drop across the filter after flushing / backwashing, shall not be more than the pressure drop under clean conditions.

3.03.00 **Operational Requirement**

The self-cleaning filter and other accessories shall be designed for the following flushing/backwashing operation modes :

3.03.01 Complete automatic flushing/backwashing operation effected by the following :-

- ◆ differential pressure measuring system at a pre-determined differential pressure across the filter
- ◆ adjustable timer (0-24 hours)
- ◆ push button (for manual initiation of sequential flushing / backwashing)

3.03.02 Manual operation in the event of failure of control system.

3.04.00 **Filter Housing / Body**

3.04.01 The self-cleaning filter housing/body shall be designed and manufactured as per the applicable codes for pressure vessels. However in no case thickness of housing/ body shall not be less than connecting pipe thickness as specified in Data Sheet-A. It shall house the filter section / screen assembly and shall have flanged inlet, outlet, flushing / debris discharge openings and pressure measuring tappings etc.

3.04.02 In design of filter housing / body due attention shall be given for easy removal and replacement of filter section / screen assembly.

3.04.03 The filter shall be provided with inspection hole with bolted cover.

	TITLE :	SPEC. NO. PE-TS- 999-165-N002
	STANDARD TECHNICAL SPECIFICATION	VOLUME : II B
	SELF - CLEANING FILTERS	SECTION : D
		REV. NO. 0 DATE : 02.12.2009
		SHEET 3 OF 10

3.04.04 The filter body / housing shall be provided with vent and drain connections with isolating valves. It shall be possible to drain unfiltered and filtered water.

3.04.05 If specified in Data Sheet-A, filter body/housing shall be epoxy painted.

3.05.00 **Filter Section / Screen assembly.**

3.05.01 The filter section/screen shall be designed for the maximum differential pressure across the filter and shall be securely positioned by a supporting cage and shall be securely mounted in the housing or body.

3.05.02 The perforation/mesh size of the filter section shall not be more than that specified in Data Sheet-A.

3.05.03 The arrangement of the filter section shall be such that there shall be no forced accumulation of debris.

3.06.00 **Differential Pressure Measuring System**

3.06.01 The self-cleaning filter shall be provided with a measuring system for differential pressure across the filter section/screen, to check debris accumulation and to initiate flushing / backwashing operation. This shall consist of a separate differential pressure transmitter for normal automatic flushing operation and separate DP Switch as a backup in the event of DPT failure, a differential pressure gauge for manual observation with adequate no. of tappings with isolating valves and equalizing valves.

3.06.02 The contacts for differential pressure transmitter, differential pressure switch and for differential pressure gauge shall be independent so that in the event of failure of one, the other is available .

3.06.03 The differential pressure measuring system shall also be equipped with built in flushing arrangement consisting of flushing pump, valves and associated piping, to prevent blockage of the system with any debris. Unless otherwise specified in Section C, water required for flushing the differential pressure measuring system shall be taken from downstream side of the strainer/ screen.

3.07.00 **Flushing / Backwash Unit :**

3.07.01 The self-cleaning filter shall be provided with suitable flushing/backwash unit (to be installed at ground floor) and debris discharge/backwash outlet valve with associated actuator to flush out the accumulated debris / sludge.

3.07.02 The flushing pump shall be provided with mechanical seals to the extent possible. If gland packing is provided it should be of good quality to prevent leakage of water from pump glands.

3.07.3 The flushing backwash unit shall be either fixed type with actuator operated

	TITLE :	SPEC. NO. PE-TS- 999-165-N002
	STANDARD TECHNICAL SPECIFICATION	VOLUME : II B
	SELF - CLEANING FILTERS	SECTION : D
		REV. NO. 0 DATE : 02.12.2009
		SHEET 4 OF 10

flushing valves or electric motor driven (through reduction gear) backwash rotor. In case of backwash rotor, it shall be fitted with removable shoes for smooth and close running contact with the filter section/screen and to prevent the unfiltered water from bypassing to waste.

3.07.04 If any water is to be injected for backwashing the filter section/screen, water shall be taken from down-stream side of the filter section/ screen with necessary pump, valves and piping for water injection supplied by the bidder.

3.07.05 View glass to be provided in debris outlet pipe to monitor the flushing of debris.

3.08.00 **Valves**

The flushing valves (if any,) the debris discharge/backwash outlet valve, isolation, vent and drain valves shall conform to appropriate codes / standards. The debris discharge/backwash outlet valve shall be larger than the debris discharge/back wash outlet pipe.

3.09.00 **Instrumentation and Control System**

3.09.01 Complete instrumentation and control system for automatic flushing / backwashing operation, protection, interlocking, indication/annunciation of high differential pressure and other malfunctions etc. shall be provided. This shall consist of adequate operational hardware, local control panel and interconnecting control and power cabling between the control panel and the self-cleaning filter and its associated electrical devices.

3.09.02 The control panel shall house all necessary instruments, indicating/ annunciation lamps, alarms, differential pressure indicator, timer, function selector switches, relays, protection and interlocking systems, start/stop push buttons, counter to register number of flushing operations etc., and shall be complete with internal wiring. In addition to the above, the control panel shall meet the requirements of the enclosed specification.

3.09.03 All instrumentation shall be of reputed make and shall meet the requirement of the enclosed specification.

3.10.00 **Other Accessories.**

3.10.01 Counter flanges, flat faced slip on type, complete with gaskets, bolts and nuts etc., shall be supplied for the filter inlet, outlet connections and all other terminal points. Fabrication, dimensions and drilling of the flanges shall conform to the codes/standards specified in Data Sheet-A.

3.10.02 Self-cleaning filter shall be provided with suitable lifting arrangement for handling during erection and maintenance.

3.10.03 Necessary supporting arrangement (wherever applicable) complete with foundation plates, bolts, nuts etc., shall be provided.

	TITLE :	SPEC. NO. PE-TS- 999-165-N002
	STANDARD TECHNICAL SPECIFICATION	VOLUME : II B
	SELF - CLEANING FILTERS	SECTION : D
		REV. NO. 0 DATE : 02.12.2009
		SHEET 5 OF 10

3.11.00 **Material of Construction**

Material of self-cleaning filter and other accessories shall be corrosion resistant and consistent with the fluid handled. However material specification for various components shall be equal or superior to those specified in Data Sheet-A.

4.00.00 **PAINTING**

4.01.00 The surface preparation of the filter housing / body and other parts shall be done as per the standard mentioned in Data Sheet-A and shall include the following :

- a) Removal of oil, grease, dirt and swarf etc.
- b) Removal of rust and scale etc.
- c) Sand blasting/shot blasting.

4.02.00 All internal surfaces of the filter which are subject to immersion or water spray and which are not made of stainless steel or other corrosion resistant materials after surface preparation, shall be coated with adequate coats (minimum 200 to 250 microns thick) of epoxy paint of approved make and quality over a coat of zinc chromite primer, unless otherwise specified in Data sheet-A.

4.03.00 The external surfaces of the filter and other accessories after surface preparation, shall be coated with adequate coats (minimum 175 to 200 microns thick) of synthetic enamel paint of approved make and quality over two coats of red oxide primer, unless otherwise specified in Data Sheet-A.

5.00.00 **SHOP INSPECTION AND TESTS**

5.01.00 **General :**

5.01.01 Manufacturer shall conduct all tests and stage inspections as per the approved quality plan to ensure that the self-cleaning filter and other accessories shall conform to the requirements of this specification and of the applicable codes/standards.

5.01.02 All materials used for manufacture/fabrication of the filter shall be of tested quality. Relevant test certificates for chemical analysis, mechanical tests and heat treatment shall be made available before the final shop inspection. In case the relevant test certificates are not available, the manufacturer shall arrange to carry out the necessary tests as per approved quality plan and applicable codes at his cost, for which samples shall be identified by BHEL's representative.

5.01.03 All shop tests shall be conducted in the presence of BHEL's representative and test certificates / reports for the same shall be furnished to BHEL for approval.

5.01.04 Qualification of welding procedures and welders shall be as per ASME B&PV

	TITLE :	SPEC. NO. PE-TS- 999-165-N002
	STANDARD TECHNICAL SPECIFICATION	VOLUME : II B
	SELF - CLEANING FILTERS	SECTION : D
		REV. NO. 0 DATE : 02.12.2009
		SHEET 6 OF 10

- Code, Section-IX / applicable codes.
- 5.02.00 **Filter Housing / Body**
- 5.02.01 Chemical analysis, mechanical tests shall be carried out on housing/body material.
- 5.02.02 All butt welded joints shall be subjected to radiographic / ultrasonic testing as per applicable codes. However all welded joints shall be subjected to 100% magnetic particle / penetrant testing to ensure freedom from defects.
- 5.03.00 **Rubber Lining (as applicable)**
- Rubber lining shall be subjected to surface crack test, 100% spark and hardness tests and shall be checked for layer thickness, defects etc.
- 5.04.00 **Filter Section/Screen assembly**
- Supporting cage and filter section/screen materials shall be tested for chemical properties. Checks shall be carried out for perforation/mesh size, defects etc.
- 5.05.00 **Flushing / Backwash Unit**
- 5.05.01 Material of various components of the flushing/Backwash Unit shall be tested for chemical and mechanical properties.
- 5.05.02 Hollow shaft of backwash rotor shall be ultrasonically tested as per ASTM-A 388 for internal flaws. Penetrant test shall be carried out for surface flaws.
- 5.06.00 **Valves**
- Inspection and testing of valves including leakage test shall be carried out as per the requirements of the applicable standards. Correlating test certificates for materials of the valve components shall be furnished.
- 5.07.00 **Flanges**
- 5.07.01 In case of fabricated flanges, all the welds shall be subjected to 100% radiography as per ASME B&PV code, section VIII, Division-1.
- 5.07.02 In case of forged flanges, ultrasonic testing shall be carried out as per ASTM-E 388.
- 5.07.03 If the thickness of the plate used for flanged is 40mm or more the same shall be checked ultrasonically as per ASTM-A 435 to demonstrate the absence of lamination and lack of fusion etc.
- 5.07.04 Chemical and mechanical test certificates shall furnish for flange materials.
- 5.07.05 Flanges shall be checked for edge preparation, fit up and satisfactory working with

	TITLE :	SPEC. NO. PE-TS- 999-165-N002
	STANDARD TECHNICAL SPECIFICATION	VOLUME : II B
	SELF - CLEANING FILTERS	SECTION : D
		REV. NO. 0 DATE : 02.12.2009
		SHEET 7 OF 10

5.08.00 matching parts.
All materials for various nozzles, seals, pipes, gaskets, nuts bolts etc., shall be of tested quality and correlating test certificates for chemical and mechanical properties shall be furnished.

5.09.00 **Dimensional Checks**

Dimensional checks of various components of the filter shall be carried out as per the drawings approved by BHEL.

5.10.00 **Hydrostatic Test**

Hydrostatic test shall be conducted on the filter housing/body at a pressure of 2 times the design pressure. The duration of the test shall be minimum 30 minutes.

5.11.00 **Leakage Test**

Leakage test shall be conducted at the design pressure to demonstrate that the filter assembly is leak tight and no water seepage shall take place at various nozzle and valve connections.

5.12.00 **Functional Tests**

The self-cleaning filter assembly complete with valves, actuators and other accessories shall be subjected to functional tests and the following shall be checked :-

5.12.01 Smooth and free operation of all movable parts.

5.12.02 Interlocks and sequential operation.

5.12.03 Satisfactory operation of actuator torque switches, limit switches etc.

6.00.00 **TESTING AT SITE**

After completion of installation at site, the self cleaning filter with complete accessories, will be tested to check that the filter performance meets the requirements of its specification, Rectification of all defects shall have to be done by the supplier at no extra cost to the Owner / Purchaser. However the Owner / Purchaser reserves the right to reject the equipment / parts not meeting the requirement if the deficiency still persists.

7.00.00 **PERFORMANCE GUARANTEE**

7.00.00 **PERFORMANCE GUARANTEE & Bid evaluation criteria**

The Self cleaning strainer shall be guaranteed to meet the performance requirements specified in Section-D , Data Sheet A and Guarantee schedule and also for trouble free operation after commissioning. Schedule of performance guarantees (enclosed in

	TITLE :	SPEC. NO. PE-TS- 999-165-N002
	STANDARD TECHNICAL SPECIFICATION	VOLUME : II B
	SELF - CLEANING FILTERS	SECTION : D
		REV. NO. 0 DATE : 02.12.2009
		SHEET 8 OF 10

Volume III) duly filled and signed shall be furnished with the bid.

The Performance guarantees of equipments shall stand valid till the satisfactory completion of performance testing & its acceptance by BHEL/ Customer. If the guarantee period specified in the Commercial Specification is higher, same shall prevail.

7.01.00 Performance Guarantee Parameters shall be as under :

- Pressure drop in Self cleaning strainer in clean condition viz. after backwashing.

7.02.01 Bidder to note that bids shall be evaluated on account of pressure drop across Self cleaning strainer (in clean condition) & liquidated damages on account of not meeting the same shall be in accordance with following :

A) Bid Evaluation Criteria and Liquidated Damages:

The bids received shall be evaluated for Pressure drop across Self cleaning strainer:

- The permissible limit of pressure drop across Self cleaning strainer in clean condition shall be 0.6 MWC.
- If the pressure drops quoted are higher than above limit, the bids shall be technically loaded @ Rate as mentioned in Data Sheet-A for respective projects per 1 MWC pressure drop (viz. per unit).
- However no advantage shall be given for pressure drops quoted less than above permissible limit.
- The maximum acceptable limit for pressure drop across self cleaning strainer (with technical loadings) shall be 1.0 MWC

The bids will be technically rejected for pressure drops quoted higher than above maximum limit.

- The guaranteed pressure drops shall be demonstrated at site by vendors and if found higher shall be subject to LD @ twice the bid evaluation factor as above.

8.00.00 QUALITY ASSURANCE & QUALITY PLAN

8.01.00 The self - cleaning filter and other accessories to be supplied shall have assured quality and workmanship.

8.02.00 Typical quality plans (Q.P. No. PEM-MSE-SQP-07) are enclosed herewith this specification for bidder's guidance. The bidder shall comply with these minimum requirements and shall furnishing own quality plan based on materials and components of the filter being offered.

9.00.00 NAME PLATE AND TAG NUMBERS

9.01.00 The filter shall be provided with a permanently attached brass or stainless steel plate indicating the following details:-

	TITLE :	SPEC. NO. PE-TS- 999-165-N002
	STANDARD TECHNICAL SPECIFICATION	VOLUME : II B
	SELF - CLEANING FILTERS	SECTION : D
		REV. NO. 0 DATE : 02.12.2009
		SHEET 9 OF 10

- a) Design flow
- b) Design and test pressures
- c) Design temperature
- d) Filter section/screen mesh size
- e) Empty and operating weights
- f) Revolving speed of backwash rotor

9.02.00 Each valve shall be provided with a name plate indicating the following :-

- a) Service
- b) Design and test pressures
- c) Maximum flow and flow direction
- d) Size
- e) Engineer's Tag Number

Tag numbers will be indicated on the drawing submitted for approval during contract stage.

9.03.00 Each motor / actuator shall be provided with a name plate indicating the following details :

- a) Supply conditions.
- b) KW Rating
- c) Make

10.00.00 **DRAWINGS, DATA & INFORMATION TO BE SUBMITTED WITH THE BID**

The bidder shall furnish the following drawings, data and information alongwith the bid without which the offer will be deemed incomplete.

10.01.00 Data sheet-B with all particulars / data duly filled in.

10.02.00 General arrangement / installation drawings of the self-cleaning filter with all accessories, incorporating the principal dimensions and weights of equipment offered, size and location of various nozzle connections, supporting arrangement (if applicable) and scope of supply etc.

10.03.00 Cross-sectional / detailed drawings of filter housing / body, filter section / screen assemblies, flushing / backwashing unit, differential pressure measuring system, actuators, motors, control panel etc., indicating bill of quantities and materials of construction.

10.04.00 Flow and control logic diagrams for complete filter during normal and flushing / backwashing operations.

10.05.00 Performance evaluation procedure at site.

	TITLE :	SPEC. NO. PE-TS- 999-165-N002
बी एच डी एल	STANDARD TECHNICAL SPECIFICATION	VOLUME : II B
	SELF - CLEANING FILTERS	SECTION : D
		REV. NO. 0 DATE : 02.12.2009
		SHEET 10 OF 10

- 10.06.00 Control panel layout and list of instruments provided on control panel.
- 10.07.00 List of annunciations, protections and interlocks provided.
- 10.08.00 Write-up on operation, control, monitoring, interlocks and protection of filter.
- 10.09.00 Manufacturer's descriptive and illustrative literature on the equipments / components being offered.
- 10.10.00 A detailed experience list about the successful installations of similar equipment of equal or higher inlet / outlet sizes and flow capacities for similar application.
- 10.11.00 A comprehensive write-up on the testing facilities, tests to be conducted inspection methods and QA system adopted by the manufacturer.
- 10.12.00 Quality plan for the self-cleaning filter and for all its accessories.
- 11.00.00 **DRAWINGS, DATA & INFORMATION TO BE SUBMITTED AFTER THE AWARD OF CONTRACT :**

The drawings, data and other documents as required in Data Sheet-C shall be furnished after the award of contract.



TITLE :
**DATA SHEET – A FOR
 SELF CLEANING STRAINERS (SCS)**

SPECIFICATION NO. SPEC. NO. **PE-TS-412-165-N003**
 VOLUME : **II B**
 SECTION : **D**
 REV. NO. **00** DATE : **16.06.15**
 Page 1 of 11

S. No.	DESCRIPTION	UNITS	2X660 MW ENNORE SEZ STPP	
1.0	GENERAL			
1.1	Type of Strainers/ Filters	-	Self Cleaning Strainers	
1.2	No. of Strainers/ Filters required	Nos.	Total 4 Sets for Total Station viz. i.e.(1 Working + 1 Standby) per unit..	
1.3	Inlet connection	mm Nb	Alternative 1	Alternative 2
			800	900
1.3	Outlet connection	mm Nb	800	900
1.4	Filter type/ duty	-	On line / continuous	
1.5	Location	-	ACW Pump discharge Header (Outdoor, approx. 100 m outside TG hall 'A'-row in transformer yard)	
1.6	Liquid handled	-	Sea Water as per analysis attached in Project information in section-B	
2.0	DESIGN DATA			
2.1	Operating pressure	Bar (g)	3.5 to 4.0	
2.2	Design pressure	Kg/cm ²	10	
2.3	Design temperature	Deg. C	60	
2.4	Flow rate through filter			
	a) Normal		4175	
	b) Maximum		5430	



TITLE :
**DATA SHEET - A FOR
 SELF CLEANING STRAINERS (SCS)**

SPECIFICATION NO. SPEC. NO. **PE-TS-412-165-N003**

VOLUME : **II B**

SECTION : **D**

REV. NO. **00** DATE : **16.06.15**

Page 2 of 11

S. No.	DESCRIPTION	UNITS	2X660 MW ENNORE SEZ STPP
2.5	Design differential pressure for filter section/ screen	Bar (g)	1.5 (Min.)
2.6	Type of suspended matter likely to enter the filter	-	Typical debris encountered in closed circuit CW system with Cooling Tower
2.7	Differential pressure measuring system set pressure <ul style="list-style-type: none"> • For initiating flushing/ backwashing • For alarm/ annunciation 	mbar mbar	110 160
2.8	Filter section/ screen perforation size	mm	2 mm (Max)
2.9	Free flow area in the screen basket	-	At least 120 % of pipe inlet area
3.0	GUARANTEED PERFORMANCE REQUIREMENT		
3.1	Pressure drop across the filter (i.e. between inlet and outlet connection) at normal flow	-	



TITLE :
**DATA SHEET – A FOR
 SELF CLEANING STRAINERS (SCS)**

SPECIFICATION NO. SPEC. NO. **PE-TS-412-165-N003**
 VOLUME : **II B**
 SECTION : **D**
 REV. NO. **00** DATE : **16.06.15**
 Page 3 of 11

S. No.	DESCRIPTION	UNITS	2X660 MW ENNORE SEZ STPP
	a) Clean condition	mbar	Refer Section – C of specification
	b) Partially (50%) choked condition	mbar	Not to exceed 110
3.2	Debris discharge flow during flushing period	Cub m/ Hr.	Not to exceed 2.5% of total flow rate
4.0	MATERIALS OF CONSTRUCTION		
4.1	Filter body/ housing	-	Duplex SS (UNS 32205/31803)
4.2	Filter screen/ section	-	Duplex SS (UNS 32205/31803)
4.3	Shaft	-	Duplex SS (UNS 32205/31803)
4.4	Supporting cage/ legs	-	Duplex SS (UNS 32205/31803)
4.5	Differential measuring system	-	Duplex SS (UNS 32205/31803)
4.6	Flushing/ backwashing unit	-	Duplex SS (UNS 32205/31803)
4.7	Backwash rotor shoes	-	Neoprene
4.8	Any other internal hardware /pipes etc.	-	Duplex SS (UNS 32205/31803)



TITLE :
**DATA SHEET – A FOR
 SELF CLEANING STRAINERS (SCS)**

SPECIFICATION NO. SPEC. NO. **PE-TS-412-165-N003**
 VOLUME : **II B**
 SECTION : **D**
 REV. NO. **00** DATE : **16.06.15**
 Page 4 of 11

S. No.	DESCRIPTION	UNITS	2X660 MW ENNORE SEZ STPP
4.9	Cover Flange/ Slipon Flange		Duplex SS (UNS 32205/31803)
4.10	Fasteners		Duplex SS (UNS 32205/31803)
4.11	Drain & Vent Plug		Duplex SS (UNS 32205/31803)
4.12	Davit Arm		Duplex SS (UNS 32205/31803)
4.13	Base Plate		Duplex SS (UNS 32205/31803)

4.14	Valves	-	
4.14.1	Check Valves (65 NB & Above)		For sizes 65 NB and above-Swing check type or dual plate type.
	a) Body & Bonnet		Duplex SS (UNS 32205/31803), Flanged Ends
	b) Disc for Check Valve		Duplex SS (UNS 32205/31803)
	c) Stem		Duplex SS (UNS 32205/31803)
4.14.2	Check Valves (50 NB & Below)		For size 50 NB and below-Piston type
	a) Body & Bonnet		Duplex SS (UNS 32205/31803), Screwed Ends
	b) Disc for Check Valve		Duplex SS (UNS 32205/31803)
	c) Stem		Duplex SS (UNS 32205/31803)
4.14.3	Globe Valves 50 Nb & Below		
	Body, Bonnet & trim		Duplex SS (UNS 32205/31803), Screwed Ends
4.14.3	➤ Gate Valves (upto 200 Nb) & BFV (Above 200 Nb)		
	➤ Body & Disc		Duplex SS (UNS 32205/31803)
	➤ Shaft		Duplex SS (UNS 32205/31803)



TITLE :
**DATA SHEET – A FOR
 SELF CLEANING STRAINERS (SCS)**

SPECIFICATION NO. SPEC. NO. **PE-TS-412-165-N003**
 VOLUME : **II B**
 SECTION : **D**
 REV. NO. **00** DATE : **16.06.15**
 Page 5 of 11

S. No.	DESCRIPTION	UNITS	2X660 MW ENNORE SEZ STPP
	➤ Stem		Duplex SS
	➤ Sealing, Retaining segment & internals		Duplex SS (UNS 32205/31803)
	➤ Bearings		Self-lubricating / Seal Lubricated
	➤ Companion Flange		Duplex SS (UNS 32205/31803)
	C) Ball valves		
	i) Body		Duplex SS (UNS 32205/31803)
	ii) Ball		Duplex SS (UNS 32205/31803)
	iii) Stem		Duplex SS (UNS 32205/31803)
4.15	Piping	-	By Purchaser
	Material		a) PIPING UPTO 150Nb SHALL BE DUPLEX SS (AS PER SCH 40S FOR PIPE UPTO 50 NB & SCH 10S FOR PIPE SIZE ABOVE 50 NB) b) PIPING 200 NB AND ABOVE SHALL BE CARBON STEEL AS PER IS 3589 FABRICATED FROM IS 2062 PLATES INTERNALLY LINED WITH CORROCOAT OR POLYUREA COATING INSIDE OF 1500 MICRONS DFT.
5.0	COUNTER FLANGES		In bidder's Scope
5.1	Material		
	Flanges		Duplex SS
5.2	Drilling Standard	-	BS 4504 or equivalent



TITLE :
**DATA SHEET - A FOR
 SELF CLEANING STRAINERS (SCS)**

SPECIFICATION NO. SPEC. NO. **PE-TS-412-165-N003**
 VOLUME : **II B**
 SECTION : **D**
 REV. NO. **00** DATE : **16.06.15**
 Page 6 of 11

S. No.	DESCRIPTION	UNITS	2X660 MW ENNORE SEZ STPP	
6.0	Connecting pipe size (OD & Thk)	mm	Option I	Option II
			813 X 10	914 X 10
7.0	PAINTING			
7.1	External Surface	-		
	a) Surface preparation	-	SA - 2.5 of Swedish Specn. SIS-05-59-00-1967 / By Sand Blasting	
	b) Primer		Two (2) coats of Epoxy primer coats with minimum thickness of 35 microns dft of each coat	
	Intermediate		Epoxy based TiO2 pigmented coat	
	c) Final paint d)		Two (2) coats of High build Epoxy paint with minimum thickness of 35 microns dft of each coat.	
7.2	Internal Surface (For components not in direct contact with Sea Water)			
	a) Surface preparation		SA - 2.5 of Swedish Specn. SIS-05-59-00-1967 / By Sand Blasting	
	b) Primer		Two coat of Epoxy Resin based Zinc Phosphate epoxy primer	
	c) Final paint		Adequate no. of coats of coal tar epoxy paint to achieve total dry film thickness of 200 to 250 microns	
8.0	SHOP TEST			
8.1	Hydrostatic test			
	a) Test Pressure	bar (g)	1.5 times design pressure	
	b) Test duration	min.	30	



TITLE :
**DATA SHEET – A FOR
 SELF CLEANING STRAINERS (SCS)**

SPECIFICATION NO. SPEC. NO. **PE-TS-412-165-N003**
 VOLUME : **II B**
 SECTION : **D**
 REV. NO. **00** DATE : **16.06.15**
 Page 7 of 11

S. No.	DESCRIPTION	UNITS	2X660 MW ENNORE SEZ STPP
8.2	Leakage test		
	a) Test Pressure	bar (g)	Design Pressure
	b) Test duration	min.	30

Bidder to note that electrical power supply shall be provided by purchaser based on electrical load list of bidder furnished at tender stage and any changes or additional requirement of electrical load by bidder during contract stage shall be provided by BHEL(purchaser) with cost repercussions to the bidder

9.0	Adequate provision for future installation of cathodic protection required		YES (Along with Sacrificial type anodic protection by Bidder)
10.0	Flow straightener for streamlining the ACW flow in SCS		If required as per bidder's design – the same to be incorporated by bidder in its constructional feature.
11.0	Performance Guarantee & Bid Evaluation		
11.1	Performance Parameters to be Guaranteed		
	❖ Pressure drop SCS		As per Guarantee schedule of bidder
11.2	Bid evaluation Criteria & Liquidated damages		As per clause no. 8.00.00 of section C1
11.3	Bid evaluation rate		@ Rs 4.85 Lacs per 0.1 MWC pr. Drop across each SCS
11.4	Liquidated damages		Twice the bid evaluation rate



TITLE :
**DATA SHEET – A FOR
 SELF CLEANING STRAINERS (SCS)**

SPECIFICATION NO. SPEC. NO. PE-TS-412-165-N003
 VOLUME : II B
 SECTION : D
 REV. NO. 00 DATE : 16.06.15
 Page 8 of 11

S. No.	DESCRIPTION	UNITS	2X660 MW ENNORE SEZ STPP
12.0	Whether automatic flushing/ back- washing operation effected by the following : i. Differential pressure ii. Adjustable timer iii. Push button		YES YES YES YES
13.0	Whether provision for manual flushing / backwashing operation is made in the event of control system failure.		YES
14.0	Whether built in flushing arrangement complete with flushing pump, valves, and associated piping, is provided.		YES (if required)
15.0	Mandatory Spare to be supplied under this specification		
1	415 V Motor		
1.1	Terminal plates	Nos.	10 Nos. each for small motors upto 30 kW & 4 Nos. each for more than 30 kW
1.2	Heaters	Set	2 Sets
1.3	Greasing arrangements	Set	4 sets each type of motor
1.4	Motor of each type and rating	Nos.	1 No.



TITLE :
**DATA SHEET - A FOR
 SELF CLEANING STRAINERS (SCS)**

SPECIFICATION NO. SPEC. NO. **PE-TS-412-165-N003**
 VOLUME : **II B**
 SECTION : **D**
 REV. NO. **00** DATE : **16.06.15**
 Page 9 of 11

S. No.	DESCRIPTION	UNITS	2X660 MW ENNORE SEZ STPP
1.5	Bearings (DE and NDE) for each type and rating of motor	Set	4 Sets
2	C&I Spares		
2.1	Each type of lamps, PBs, ILPBs, fuse, MCB, MCCB used in the equipment/system.	Nos.	20% of installed of each type
2.2	Indicators, recorders and meters offered from each model for the project. These instruments shall be supplied with three sets of blank scales.	Nos.	10 % of Installed of each type/Model or a minimum of one number for each model and type, whichever is more
2.3	For skid mounted instruments	Nos.	10 % of total no. of instruments for each type and Model or a minimum of one number for each model and type, whichever is more
2.4	Temperature, Transmitters and Electronic Transmitters (For Pressure, DP, Temp, Flow, Level), Temperature, Pressure, Flow & Level Switch, safety switches, Gauges, meters, Transducer or any other instrument etc.	Nos.	10% of total number of Instruments/transducers offered for each model and type for the project or a minimum of one number, whichever is more.



TITLE :
**DATA SHEET - A FOR
SELF CLEANING STRAINERS (SCS)**

SPECIFICATION NO. SPEC. NO. PE-TS-412-165-N003
VOLUME : II B
SECTION : D
REV. NO. 00 DATE : 16.06.15
Page 10 of 11

S. No.	DESCRIPTION	UNITS	2X660 MW ENNORE SEZ STPP
2.5	Hooters, Buzzers, Cooling fans of each type.	Nos.	Ten (10) percent or 2 no. (Whichever is more)
2.6	Interface cables	Set	2 sets of each type/model
2.7	Power supply modules (AC to DC Convertors)	Nos.	10% or Five no. (Whichever is more) of each type/model
2.8	Relay based Control Panels		
2.8.1	LEDs for indicating lights	Nos.	10% of qty installed.
2.8.2	Control circuit fuses/MCB/MCCB/ Semiconductor Fuses	Nos.	300% of installed of each type, current rating.
2.8.3	Relays modules & contactors.	Nos.	20% spare of qty Installed of each type & rating.
2.9	Alarm Annunciation System		
2.9.1	logic modules, group card modules, power supply modules, Hooters and any other electronic module.	Nos.	20% spares of each type installed
2.9.2	un-engraved window boxes complete with LED etc.	Nos.	5% spares of each type installed

	TITLE : DATA SHEET - A FOR SELF CLEANING STRAINERS (SCS)		SPECIFICATION NO. SPEC. NO. PE-TS-412-165-N003	
			VOLUME : II B	
			SECTION : D	
			REV. NO. 00 DATE : 16.06.15	
			Page 11 of 11	
S. No.	DESCRIPTION	UNITS	2X660 MW ENNORE SEZ STPP	
2.9.3	LEDs for annunciation facia windows and LEDs box assemblies offered for the project	Nos.	20% of qty installed	
2.9.4	Annunciator hooter	Nos.	One (1) No. of each type	
2.10	Erection Hardware			
2.10.1	Instrument valves	Nos.	Ten (10) percent of each type & Size installed	
2.10.2	Condensate pots of each type & Size installed	Nos.	Ten (10) percent of total number of Installed or four numbers whichever is higher .	
2.10.3	Manifold	Nos.	Ten (10) percent of each type & Size installed	
2.10.4	Fittings	Nos.	Ten (10) percent of each type & Size installed	
Notes for Mandatory Spares: <ol style="list-style-type: none"> 1. For C&I Mandatory Spare not covered above: Bidder to supply 10% or 1 no. (whichever is more) of each type of sensor/instrument, instrumentation/mechanical fittings etc for any other electronic system, feeder control cabinets, hydrastep (EWLI), Vibration Monitoring System, CCTV, C&I Lab Instruments, On line Carbon in Ash analyser system, On line Coal mass flow/speed measurement system, On line secondary air flow measurement system Mass Flow meter, Solid flow meter, 3 D Acoustic type level transmitters, Nucleonic & non nucleonic density transmitter etc. 2. All Spares mentioned at S.No. 1 are for Two 660 MW units. 3. All Spares mentioned at S.No. 2 are per 660 MW unit basis. 4. Spares not applicable for the Package to be specifically quoted as "NOT APPLICABLE". 				

Pipe Size Table		
(Refer Cl. No. 6.2, Section C1, Vol-II B)		
Pipe		
Duplex SS		
NB	OD	Thick
25	33.40	3.4
50	60.30	3.9
100	114.30	3.1
150	168.30	3.4
800	813.00	7.92
900	914.00	7.92
1000	1016.00	7.92
1100	1118.00	8.74
CS		
200	219.10	6.40
250	273.00	6.40
300	323.80	6.40
350	355.60	8.0
600	610.00	8.0
700	711.20	10.0
800	813.00	10.0
900	914.00	10.0

Manufacturer's Name & Address		STANDARD QUALITY PLAN		BHEL Doc No.: PE-V4-XXX-165-N08	
P.O. No.		Item:	Vendor O.P. NO.	PROJECT:	
		Self Cleaning Strainer	PACKAGE : SELF CLEANING STRAINER	CUSTOMER:	
			Date :	PURCHASER:	
			Page 01 of 12	CONSULTANT:	
SL. NO.	DESCRIPTION	PAGE NOS.			
1	SELF CLEANING STRAINER	2-4			
2	BALL VALVES	5			
3	BUTTERFLY VALVES	6			
4	PRESSURE GAUGE, DP GAUGE, DP SWITCH DP TRANSMITTER	7			
5	GEAR MOTOR DRIVE & WORM PLANETARY GEAR BOX	8			
6	ACTUATORS	9			
7	STARTER PANEL	10			
8	FASTENERS	11			
9	ALL COMPONENT / EQUIPMENT	12			
	ANNEXURES				
	DRY RUN TEST PROCEDURE	2			
	HYDRO TEST PROCEDURE	2			
	HYDRO STATIC LEAK TIGHTNESS TESTING PROCEDURE	2			
	PACKING PROCEDURE	1			
Note: Items not included in quality plan to be inspected as per Approved datasheet/drawings.					
LEGEND * Records identified with "STAR" shall be essentially included by contractor in QA Documentation. ** M : Manufacturer/ Sub-contractor C : CONTRACTOR O: OWNER Indicate : "P" - Perform, "W" - Witness and "V" - Verification					
Manufacturer / Sub-Contractor Signature		Name & Sign. Of approving authority & Seal			

Manufacturer's Name & Address		STANDARD QUALITY PLAN		BHEL Doc No.: PE-V4-XXX-165-N08						
Item :		Vendor Q.P. NO.		PROJECT:						
Self Cleaning Strainer		PACKAGE : SELF CLEANING STRAINER		CUSTOMER:						
P.O. No.		Date :		PURCHASER:						
		Page 02 of 12		CONSULTANT:						
Sl. No.	Component / Operation	Characteristics Checked	Class	Type of Check	Quantum of Check	Reference Documents	Acceptance Norms	Format of Record	Agency	Remarks
1	2	3	4	5	6	7	8	9	M C O	11
1.0.0	SELF CLEANING STRAINER									
1.1.0	Raw Material									
[a]	Housing Shell, Nozzle flanges & Main flanges/Counter Flange	Chemical properties	Major	Chemical Analysis	One sample/cast / heat / batch	Approved dtg/Data sheet	Approved dtg/Data sheet	Mill Test Certificate / lab test report / raw material flow sheet	P V	All raw material identification as per manufacturer/CLab report by BHEL
		Physical properties	Major	Physical test	One sample/cast / heat / batch	Approved dtg/Data sheet	Approved dtg/Data sheet	Mill Test Certificate / lab test report / raw material flow sheet	P V	
		Surface Defects	Minor	Visual	100%	Approved dtg/Data sheet	ASME A 435/A609	Mill Test Certificate / Inspection Report	P V	
		Sub Surface Defects	Major	Ultrasonic Test	100%	ASME A 435/A609		Inspection Report	P V	Plates > 20mm Thk only
[b]	Nozzle Pipes	Chemical properties	Major	Chemical Analysis	One sample/cast / heat / batch	Approved dtg/Data sheet	Approved dtg/Data sheet	Mill Test Certificate / lab test report / raw material flow sheet	P V	
		Physical properties	Major	Physical test	One sample/cast / heat / batch	Approved dtg/Data sheet	Approved dtg/Data sheet	Mill Test Certificate / lab test report / raw material flow sheet	P V	
		Surface defects	Minor	Visual	100%	Approved dtg/Data sheet	Approved dtg/Data sheet	Mill Test Certificate / Inspection Report	P V	
		Leak tightness	Major	Hydrostatic test	100%	Approved dtg/Data sheet	Approved dtg/Data sheet	Mill Test Certificate / Inspection Report	P V	
[c]	Screen basket, Nozzle flanges	Chemical properties	Major	Chemical Analysis	One sample/cast / heat / batch	Approved dtg/Data sheet	Approved dtg/Data sheet	Mill Test Certificate / lab test report / raw material flow sheet	P V	
		Physical properties	Major	Physical test	One sample/cast / heat / batch	Approved dtg/Data sheet	Approved dtg/Data sheet	Mill Test Certificate / lab test report / raw material flow sheet	P V	
		Surface Defects	Minor	Visual	100%	Approved dtg/Data sheet	ASME A 745	Mill Test Certificate / Inspection Report	P V	Plates > 20mm Thk only (UT full volume)
		Sub-surface defects	Major	Ultrasonic test	100%	ASME A 745	ASME A 745	Inspection report	P V	
		Corrosion Resistance	Major	IGCI	One/Heat	ASTM A 262	Practice E of ASTM A 262	Test Report	P V	
LEGEND * Records identified with "STAR" shall be essentially included by contractor in QA Documentation. M - Manufacturer/ Sub-contractor C - CONTRACTOR O - OWNER Indicate - "P" - Perform, "W" - Witness and "V" - Verification										
Manufacturer/ Sub-Contractor Signature _____ Contractor _____ Name & Sign. Of approving authority & Seal _____										

STANDARD QUALITY PLAN		Item :		Vendor O.P. No.		BHEL Doc No.: PE-V4-XXX-165-N08			
Manufacturer's Name & Address		Self Cleaning Strainer		PACKAGE : SELF CLEANING STRAINER		PROJECT:			
P.O. No.		Reference Documents		Date :		CUSTOMER:			
Characteristics Checked		Quantum of Check		Page 04 of 12		PURCHASER:			
Class		Type of Check		Acceptance Norms		CONSULTANT:			
3		4		7		M C O			
2		5		8		= 10			
1		6		9		Remarks			
11		10		11		11			
1.2.8	Pickling and Passivation	Protection Layer	Major	Visual	100%	IS : 10117	Log Book	P	-
1.2.9	Fabricated Shell (Prior to sand blasting)	1. Dimensions, Orientation 2. Hydro test	Major Critical	Measurement by visual Hydrostatic Pr. @ 1.5 times of design pr.(positive) [Duration 30 minutes]	100%	Manufacturing Drawing ASME Sec.VIII ASME Sec.VIII Div.1	Inspection report Inspection report	* *	V V
1.3.0	Final tests (completed equipments) - After assembly	1. Dimensions, orientation, workmanship & finish 2. Leak tightness for assembly 3. Dry function test for Debris filter	Major Critical Critical	Measurement by visual Leak test @ design pr.(positive) [Duration 30 minutes] Operational test	100%	G.A.drawing ASME Sec.VIII No leakage Div.1 Approved Procedure	Inspection report Inspection report Inspection report	* * *	V W V
1.4.0	Rubber Lining (Shell)	Tensile, elongation & Major hardness	Major	Physical test	One per lot	Manufacturer's procedure	Manufacturers certificate	*	V
1.4.1	Rubber Formulation	Polymer identification	Major	Flame test	One per lot	For Semi Ebonite For Ebonite Polymer/Ebonite Polymer catches catches fire and fire and on removal from on removal, flame continues to burn	Inspection report	P	V
1.4.2	Surface preparation of items to be lined	% Change in weight after 24 hours of immersion in sea water at 70°	Major	Immersion test (One period bleeding test)	One per lot	ASTM D 471	Inspection report	P	V
1.4.3	Vulcanising	Free from rust, scale,dust & grease Temperature, Pressure & Time	Major	Visual	100%	SA 2.5	Manufacturers Internal Inspection report	P	-
1.4.4	Vulcanised Rubber Lined items	(a) Chip test (b) Adhesion, Visual defects, Thickness & Hardness (c) Spark test for Pin Holes at 5 kv/mm	Major Major Major	Process monitoring Chip test Measurement, Visual Inspection Spark test for Pin Holes	100%	Manufacturer's procedure Approved Drawing BS 6374:Equivalent & BS 6374:Equivalent visual, Approved Drawing BS 6374:Equivalent & BS 6374:Equivalent Approved Drawing BS 6374:Equivalent & BS 6374:Equivalent	Manufacturers Inspection report Process Procedure Inspection report Inspection report Inspection report	* * *	V V V
LEGEND * Records identified with "STAR" shall be essentially included by contractor in QA Documentation. ** M : Manufacturer/ Sub-contractor C : CONTRACTOR O: OWNER Indicate : 'P' - Perform, 'W' - Witness and 'V' - Verification									
Manufacturer / Sub-Contractor Signature									
Contractor Signature									
Name & Sign. Of approving authority & Seal									

STANDARD QUALITY PLAN		Manufacturer's Name & Address		Item :		Vendor / P. No.		BHEL Doc No.: PE-V4-XXX-165-N08	
P.O. No.		Ball Valves		PACKAGE : SELF CLEANING STRAINER		CUSTOMER:		PURCHASER:	
Date :		Page 05 of 12		Date :		CONSULTANT:		Agency	
Acceptance Norms		Reference Documents		Quantum of Check		Format of Record		M C O	
8		7		6		9		10	
Remarks		11							
Sl. No.	Component / Operation	Characteristics Checked	Class	Type of Check	Quantum of Check	Reference Documents	Acceptance Norms	Format of Record	Remarks
1	2	3	4	5	6	7	8	9	11
2.0.0	Ball valves								
2.1.0	Materials	Chemical properties	Major	Chemical properties	One Sample/Cast / heat	Approved dfg/Data sheet	Approved dfg/Data sheet	Manufacturer's T.C.	* P V V
	Body and Tail end pieces	Physical properties	Major	Physical properties	One Sample/Cast / heat / batch	Approved dfg/Data sheet	Approved dfg/Data sheet	Manufacturer's T.C.	* P V V
2.1.1	Ball	Chemical properties	Major	Chemical properties	One Sample/Cast / heat	Approved dfg/Data sheet	Approved dfg/Data sheet	Manufacturer's T.C.	* P V V
		Physical properties	Major	Physical properties	One Sample/Cast / heat / batch	Approved dfg/Data sheet	Approved dfg/Data sheet	Manufacturer's T.C.	* P V V
2.1.2	Stem	Chemical properties	Major	Chemical properties	One Sample/Cast / heat	Approved dfg/Data sheet	Approved dfg/Data sheet	Manufacturer's T.C.	* P V V
		Physical properties	Major	Physical properties	One Sample/Cast / heat / batch	Approved dfg/Data sheet	Approved dfg/Data sheet	Manufacturer's T.C.	* P V V
2.2.0	In-process inspection								
2.2.1	Ball	Hardness	Major	Hardness Testing	Random	Approved / Dfg / Data Sheet	Approved / Dfg / Data Sheet	Manufacturers TC	* P V V
2.3.0	Assembly	a) Dimensions	Major	Measurement	100%	Approved dfg/Data sheet	Approved dfg/Data sheet	Manufacturer's T.C.	* P V V
		b) Opening / Closing	Major	Operation	100%	--	As per approved data sheet	--	P -- V
2.4.0	Testing								
	a) Body	Leakage	Critical	Hydraulic test	100%	EN 12266-1&2	EN 12266-1&2 / Appd. Data sheet	Manufacturer's T.C.	* P V V
	b) Seat test	Leakage	Critical	Hydraulic test	100%	EN 12266-1&2	EN 12266-1&2 / Appd. Data sheet	Manufacturer's T.C.	* P V V
	c) Seat	Leakage	Critical	Air test	100%	EN 12266-1&2	EN 12266-1&2 / Appd. Data sheet	Manufacturer's T.C.	* P V V
LEGEND									
* Records identified with "STAR" shall be essentially included by contractor in QA Documentation.									
** M : Manufacturer/ Sub-contractor									
C : CONTRACTOR									
O: OWNER									
I: OWNER									
Indicate : "P" - Perform, "W" - Witness and "V" - Verification									
Manufacturer / Sub-Contractor Signature									
Contractor									
Name & Sign. Of approving authority & Seal									

Manufacturer's Name & Address		Manufacturer's Name & Address		Manufacturing Quality Plan		BHEL Doc No.: PE-V4-XXX-165-N08					
P.O. No.		Item : Pressure Gauge, DP Gauge, DP switch&DP Transmitter		Vendor Q.P. NO.		PROJECT:					
Characteristics Checked		Quantum of Check		Acceptance Norms		CUSTOMER:					
3		6		8		PURCHASER:					
Class		Type of Check		References Documents		CONSULTANT:					
4		5		7							
Component / Operation		Type of Check		Format of Record		Agency					
2		5		9		M C O					
1		4		10		11					
4.0.0	In process quality control	Make, Range and Critical Model	Visual	100%	Approved Data Sheet	Data Approved Data Sheet	Manufacturer test certificate	*	P	V	V
		Calibration	Calibration test	100%	Approved Data Sheet	Data Approved Data Sheet	Manufacturer test certificate	*	V	V	V
		Degree of protection	-	Type test certificate	Approved Data Sheet	Data Approved Data Sheet	Manufacturer test certificate	*	V	V	V
<p style="text-align: center;">DMS (BHEL/PEM) 3062643/2014/05/29</p>											
<p>LEGEND</p> <p>* Records identified with "STAR" shall be essentially included by contractor in QA Documentation.</p> <p>** M : Manufacturer/ Sub-contractor</p> <p>C : CONTRACTOR</p> <p>O: OWNER</p> <p>Indicate : "P" - Perform, "V" - Witness and "Y" - Verification</p>											
<p>Manufacturer / Sub-Contractor Signature</p>											
<p>Contractor</p>											
<p>Name & Sign. Of approving authority & Seal</p>											



Manufacturer's Name & Address		Item : Actuators		Manufacturing Quality Plan		BHEL Doc No.: PE-V4-XXX-165-N08		
P.O. No.		Vendor Q.P. NO.		PACKAGE : SELF CLEANING STRAINER		PROJECT:		
Characteristics Checked		Date :		Page 09 of 12		PURCHASER:		
Class		Reference Documents		Acceptance Norms		CONSULTANT:		
Type of Check		Quantum of Check		Format of Record		Agency		
3		6		9		M C O		
4		7		8		10		
5		8		9		11		
6.0.0	Actuators	Major	Electrical test	100%	Supplier catalogue/Appd data sheet	Supplier catalogue/Appd Test certificate	* P V V	
	Make, Range, Model	Major	Visual	100%	Supplier catalogue/Appd data sheet	Supplier catalogue/Appd Inspection Report	- P - -	
	Assembly check alongwith valves	Major	Visual	100%	Supplier catalogue/Appd data sheet	Supplier catalogue/Appd Inspection Report	- P - -	
	Functional check along with settings / Auxiliary Circuits	Major	Visual	100%	Supplier catalogue	Supplier catalogue/Appd Inspection Report	- P - -	Review of TC's
LEGEND * Records identified with "STAR" shall be essentially included by contractor in QA Documentation. ** M - Manufacturer/ Sub-contractor C - CONTRACTOR O- OWNER Indicate : "P" - Perform, "V" - Witness and "Y" - Verification								
Manufacturer / Sub-Contractor Signature		Contractor						Name & Sign. Of approving authority & Seal

DMS (BHEL/PEM)
3062643-2014/05/29

Manufacturer's Name & Address		Item : Starter Panel		Manufacturing Quality Plan		BHEL Doc No.: PE-VA-XXX-165-N08		
P.O. No.		Reference Documents		Vendor Q.P. NO.		PROJECT:		
Characteristics Checked		Quantum of Check		Acceptance Norms		CUSTOMER:		
Class		Type of Check		Format of Record		PURCHASER:		
3		4		5		CONSULTANT:		
6		7		8		Agency		
9		10		11		Remarks		
Sl. No.	Component / Operation	Class	Type of Check	Quantum of Check	Reference Documents	Format of Record	M C O	
1								
7.0.0	Starter panel							
7.1.0	Incoming Material							
7.1.1	Fabricated & Painted Panel	Major	Measurement	100%	Approved Drgs.	Inspection report	P -- --	
	Panel G.A.	Major	Measurement	100%	Approved Drgs.	Inspection report	P -- --	
	Paint colour	Major	Visual	100%	Approved Drgs.	Inspection report	P -- --	
	Paint thickness	Major	Measurement	100%	Approved Drgs.	Inspection report	P -- --	
	Paint Shade, Adhesion	Major	Visual	Sample	Approved Drgs.	Inspection report	P -- --	
7.1.2	Wire	Major	Visual / Dimension	Sample	IS 694	Inspection report	P -- --	
7.1.3	Panel Mounting	Major	Visual / Electrical	100%	Approved BOM	---	P V V	
7.2.0	In Process Inspection							
7.2.1	Name Plate, Component Mounting, Etc.	Major	Visual	100%	Approved Drgs.	Inspection report	P -- --	
7.2.2	Electrical Wiring of Panels	Major	Visual	100%	Mounting Drawing	Inspection report	P -- --	
7.2.3	Feruling of Cables	Major	Visual	100%	Manufacturer's drawing	Inspection report	P -- --	
7.3.0	Final Inspection							
7.3.1	Workmanship, Finish & Paint shade / Thickness	Major	Visual	100%	G.A Drawing	Inspection report	* P W V	
7.3.2	Overall Dimension, G.A of starter panel	Major	Visual	100%	G.A Drawing	Test Certificate	P W V	
7.3.3	Component Identification	Major	Visual	100%	G.A Drawing	Inspection report	P W V	
7.3.4	IR - HV - IR	Critical	Electrical	100%	Mfg.Procedure	Inspection report	P W V	
7.3.5	Functional & Continuity	Major	Functional	100%	Appd Drawing	Inspection report	* P W V	
LEGEND								
* Records identified with "STAR" shall be essentially included by contractor in QA Documentation.								
** H : Manufacturer/ Sub-contractor								
C : CONTRACTOR/ Sub-contractor								
O : OWNER								
Indicate : 'P' - Perform, 'W' - Witness and 'V' - Verification								
Manufacturer / Sub-Contractor Signature		Contractor						Name & Sign. Of approving authority & Seal

Manufacturer's Name & Address		Item : Fasteners		Manufacturing Quality Plan		BHEL Doc No.: PE-VA-XXX-165-N08	
P.O. No.		Vendor Q.P. NO.		PACKAGE : SELF CLEANING STRAINER		PROJECT:	
		Date :		Date :		CUSTOMER:	
		Page 11 of 12		Page 11 of 12		PURCHASER:	
		Reference Documents		Format of Record		CONSULTANT:	
		Quantum of Check		Acceptance Norms		M C O	
		Type of Check		Norms		10	
		Class		7			
		Characteristics Checked		6			
		3		5			
		4		8			
		5		9			
		6		10			
		7		11			
		8		12			
		9		13			
		10		14			
		11		15			
		12		16			
		13		17			
		14		18			
		15		19			
		16		20			
		17		21			
		18		22			
		19		23			
		20		24			
		21		25			
		22		26			
		23		27			
		24		28			
		25		29			
		26		30			
		27		31			
		28		32			
		29		33			
		30		34			
		31		35			
		32		36			
		33		37			
		34		38			
		35		39			
		36		40			
		37		41			
		38		42			
		39		43			
		40		44			
		41		45			
		42		46			
		43		47			
		44		48			
		45		49			
		46		50			
		47		51			
		48		52			
		49		53			
		50		54			
		51		55			
		52		56			
		53		57			
		54		58			
		55		59			
		56		60			
		57		61			
		58		62			
		59		63			
		60		64			
		61		65			
		62		66			
		63		67			
		64		68			
		65		69			
		66		70			
		67		71			
		68		72			
		69		73			
		70		74			
		71		75			
		72		76			
		73		77			
		74		78			
		75		79			
		76		80			
		77		81			
		78		82			
		79		83			
		80		84			
		81		85			
		82		86			
		83		87			
		84		88			
		85		89			
		86		90			
		87		91			
		88		92			
		89		93			
		90		94			
		91		95			
		92		96			
		93		97			
		94		98			
		95		99			
		96		100			
		97		101			
		98		102			
		99		103			
		100		104			
		101		105			
		102		106			
		103		107			
		104		108			
		105		109			
		106		110			
		107		111			
		108		112			
		109		113			
		110		114			
		111		115			
		112		116			
		113		117			
		114		118			
		115		119			
		116		120			
		117		121			
		118		122			
		119		123			
		120		124			
		121		125			
		122		126			
		123		127			
		124		128			
		125		129			
		126		130			
		127		131			
		128		132			
		129		133			
		130		134			
		131		135			
		132		136			
		133		137			
		134		138			
		135		139			
		136		140			
		137		141			
		138		142			
		139		143			
		140		144			
		141		145			
		142		146			
		143		147			
		144		148			
		145		149			
		146		150			
		147		151			
		148		152			
		149		153			
		150		154			
		151		155			
		152		156			
		153		157			
		154		158			
		155		159			
		156		160			
		157		161			
		158		162			
		159		163			
		160		164			
		161		165			
		162		166			
		163		167			
		164		168			
		165		169			
		166		170			
		167		171			
		168		172			
		169		173			
		170		174			
		171		175			
		172		176			
		173		177			
		174		178			
		175		179			
		176		180			
		177		181			
		178		182			
		179		183			
		180		184			
		181		185			
		182		186			
		183		187			
		184		188			
		185		189			
		186		190			
		187		191			
		188		192			
		189		193			
		190		194			
		191		195			
		192		196			
		193		197			
		194		198			
		195		199			
		196		200			
		197		201			
		198		202			
		199		203			
		200		204			
		201		205			
		202		206			
		203		207			
		204		208			
		205		209			
		206		210			
		207		211			
		208		212			
		209		213			
		210		214			
		211		215			
		212		216			
		213		217			
		214		218			
		215		219			
		216		220			
		217		221			
		218		222			
		219		223			
		220		224			
		221		225			
		222		226			
		223		227			
		224		228			
		225		229			
		226		230			
		227		231			
		228		232			
		229		233			
		230		234			
		231		235			
		232		236			
		233		237			
		234		238			
		235		239			
		236		240			
		237		241			
		238		242			
		239		243			
		240		244			
		241		245			
		242		246			
		243		247			
		244		248			
		245		249			
		246		250			
		247		251			
		248		252			
		249		253			
		250		254			
		251		255			
		252		256			
		253		257			
		254		258			
		255		259			
		256		260			
		257		261			
		258		262			
		259		2			



TITLE : TECHNICAL SPECIFICATION
FOR
SELF CLEANING STRAINERS

SPEC. NO. PE-TS- 412-165-N003

VOLUME : IIB

SECTION : C

REV. NO. 0

DATE :
16.06.15

SHEET 1 of 1

SECTION D2
STANDARD TECHNICAL SPECIFICATION
FOR
ELECTRICAL SYSTEMS



TITLE :
GENERAL TECHNICAL REQUIREMENTS

FOR

LV MOTORS

SPECIFICATION NO. PE-SS-999-506-E101
VOLUME NO. : II-B
SECTION : D
REV NO. : 00 DATE : 29/08/2005
SHEET : 1 OF 1

GENERAL TECHNICAL REQUIREMENTS

FOR

LV MOTORS

SPECIFICATION NO.: PE-SS-999-506-E101 Rev 00



TITLE :
GENERAL TECHNICAL REQUIREMENTS

FOR

LV MOTORS

SPECIFICATION NO.
PE-SS-999-506-E101
VOLUME NO. : **II-B**
SECTION : **D**
REV NO. : **00** DATE : 29/08/2005
SHEET : 1 OF 4

1.0 INTENT OF SPECIFICATION

The specification covers the design, materials, constructional features, manufacture, inspection and testing at manufacturer's work, and packing of Low voltage (LV) squirrel cage induction motors along with all accessories for driving auxiliaries in thermal power station.

Motors having a voltage rating of below 1000V are referred to as low voltage (LV) motors.

2.0 CODES AND STANDARDS

Motors shall fully comply with latest edition, including all amendments and revision, of following codes and standards:

IS:325	Three phase Induction motors
IS : 900	Code of practice for installation and maintenance of induction motors
IS: 996	Single phase small AC and universal motors
IS: 4722	Rotating Electrical machines
IS: 4691	Degree of Protection provided by enclosures for rotating electrical machines
IS: 4728	Terminal marking and direction of rotation rotating electrical machines
IS: 1231	Dimensions of three phase foot mounted induction motors
IS: 8789	Values of performance characteristics for three phase induction motors
IS: 13555	Guide for selection and application of 3-phase A.C. induction motors for different types of driven equipment
IS: 2148	Flame proof enclosures for electrical appliance
IS: 5571	Guide for selection of electrical equipment for hazardous areas
IS: 12824	Type of duty and classes of rating assigned
IS: 12802	Temperature rise measurement for rotating electrical machines
IS: 12065	Permissible limits of noise level for rotating electrical machines
IS: 12075	Mechanical vibration of rotating electrical machines

In case of imported motors, motors as per IEC-34 shall also be acceptable.

3.0 DESIGN REQUIREMENTS

3.1 Motors and accessories shall be designed to operate satisfactorily under conditions specified in data sheet-A and Project Information, including voltage & frequency variation of supply system as defined in Data sheet-A

3.2 Motors shall be continuously rated at the design ambient temperature specified in Data Sheet-A and other site conditions specified under Project Information
Motor ratings shall have at least a 15% margin over the continuous maximum demand of the driven equipment, under entire operating range including voltage & frequency variation specified above.

3.3 Starting Requirements

3.3.1 Motor characteristics such as speed, starting torque, break away torque and starting time shall be properly co-ordinated with the requirements of driven equipment. The accelerating torque at any speed with the minimum starting voltage shall be at least 10% higher than that of the driven equipment.

3.3.2 Motors shall be capable of starting and accelerating the load with direct on line starting without exceeding acceptable winding temperature.



TITLE :
GENERAL TECHNICAL REQUIREMENTS

FOR

LV MOTORS

SPECIFICATION NO.
PE-SS-999-506-E101
VOLUME NO. : **II-B**
SECTION : **D**
REV NO. : **00** DATE : 29/08/2005
SHEET : 2 OF 4

The limiting value of voltage at rated frequency under which a motor will successfully start and accelerate to rated speed with load shall be taken to be a constant value as per Data Sheet - A during the starting period of motors.

3.3.3 The following frequency of starts shall apply

- i) Two starts in succession with the motor being initially at a temperature not exceeding the rated load temperature.
- ii) Three equally spread starts in an hour the motor being initially at a temperature not exceeding the rated load operating temperature. (not to be repeated in the second successive hour)
- iii) Motors for coal conveyor and coal crusher application shall be suitable for three consecutive hot starts followed by one hour interval with maximum twenty starts per day and shall be suitable for minimum 20,000 starts during the life time of the motor

3.4 **Running Requirements**

3.4.1 Motors shall run satisfactorily at a supply voltage of 75% of rated voltage for 5 minutes with full load without injurious heating to the motor.

3.4.2 Motor shall not stall due to voltage dip in the system causing momentary drop in voltage upto 70% of the rated voltage for duration of 2 secs.

3.5 **Stress During bus Transfer**

3.5.1 Motors shall withstand the voltage, heavy inrush transient current, mechanical and torque stress developed due to the application of 150% of the rated voltage for at least 1 sec. caused due to vector difference between the motor residual voltage and the incoming supply voltage during occasional auto bus transfer.

3.5.2 Motor and driven equipment shafts shall be adequately sized to satisfactorily withstand transient torque under above condition.

3.6 Maximum noise level measured at distance of 1.0 metres from the outline of motor shall not exceed the values specified in IS 12065.

3.7 The max. vibration velocity or double amplitude of motors vibration as measured at motor bearings shall be within the limits specified in IS: 12075.

4.0 **CONSTRUCTIONAL FEATURES**

4.1 Indoor motors shall conform to degree of protection IP: 54 as per IS: 4691. Outdoor or semi-indoor motors shall conform to degree of protection IP: 55 as per IS: 4691 and shall be of weather-proof construction. Outdoor motors shall be installed under a suitable canopy

4.2 Motors upto 160KW shall have Totally Enclosed Fan Cooled (TEFC) enclosures, the method of cooling conforming to IC-0141 or IC-0151 of IS: 6362.

Motors rated above 160 KW shall be Closed Air Circuit Air (CACA) cooled

4.3 Motors shall be designed with cooling fans suitable for both directions of rotation.

	TITLE :	SPECIFICATION NO.
	GENERAL TECHNICAL REQUIREMENTS	PE-SS-999-506-E101
	FOR	VOLUME NO. : II-B
	LV MOTORS	SECTION : D
		REV NO. : 00 DATE : 29/08/2005
		SHEET : 3 OF 4

- 4.4. Motors shall not be provided with any electric or pneumatic operated external fan for cooling the motors.
- 4.5. Frames shall be designed to avoid collection of moisture and all enclosures shall be provided with facility for drainage at the lowest point.
- 4.6. In case Class 'F' insulation is provided for LV motors, temperature rise shall be limited to the limits applicable to Class 'B' insulation.
In case of continuous operation at extreme voltage limits the temperature limits specified in table-1 of IS:325 shall not exceed by more than 10°C.
- 4.7 Terminals and Terminal Boxes**
- 4.7.1 Terminals, terminal leads, terminal boxes, windings tails and associated equipment shall be suitable for connection to a supply system having a short circuit level, specified in the Data Sheet-A.

Unless otherwise stated in Data Sheet-A, motors of rating 110 kW and above will be controlled by circuit breaker and below 110 kW by switch fuse-contactor. The terminal box of motors shall be designed for the fault current mentioned in data sheet "A".
- 4.7.2 unless otherwise specified or approved, phase terminal boxes of horizontal motors shall be positioned on the left hand side of the motor when viewed from the non-driving end.
- 4.7.3 Connections shall be such that when the supply leads R, Y & B are connected to motor terminals A B & C or U, V & W respectively, motor shall rotate in an anticlockwise direction when viewed from the non-driving end. Where such motors require clockwise rotation, the supply leads R, Y, B will be connected to motor terminals A, C, B or U W & V respectively.
- 4.7.4 Permanently attached diagram and instruction plate made preferably of stainless steel shall be mounted inside terminal box cover giving the connection diagram for the desired direction of rotation and reverse rotation.
- 4.7.5 Motor terminals and terminal leads shall be fully insulated with no bar live parts. Adequate space shall be available inside the terminal box so that no difficulty is encountered for terminating the cable specified in Data Sheet-A.
- 4.7.6 Degree of protection for terminal boxes shall be IP 55 as per IS 4691.
- 4.7.7 Separate terminal boxes shall be provided for space heaters.. If this is not possible in case of LV motors, the space heater terminals shall be adequately segregated from the main terminals in the main terminal box. Detachable gland plates with double compression brass glands shall be provided in terminal boxes.
- 4.7.8. Phase terminal boxes shall be suitable for 360 degree of rotation in steps of 90 degree for LV motors.
- 4.7.9 Cable glands and cable lugs as per cable sizes specified in Data Sheet-A shall be included. Cable lugs shall be of tinned Copper, crimping type.
- 4.8 Two separate earthing terminals suitable for connecting G.I. or MS strip grounding conductor of size given in Data Sheet-A shall be provided on opposite sides of motor frame. Each terminal box shall have a grounding terminal.



TITLE :
GENERAL TECHNICAL REQUIREMENTS

FOR

LV MOTORS

SPECIFICATION NO.
PE-SS-999-506-E101
VOLUME NO. : **II-B**
SECTION : **D**
REV NO. : **00** DATE : 29/08/2005
SHEET : 4 OF 4

- 4.9.1 Motors provided for similar drives shall be interchangeable.
- 4.9.2 Suitable foundation bolts are to be supplied alongwith the motors.
- 4.9.3 Motors shall be provided with eye bolts, or other means to facilitate safe lifting if the weight is 20Kgs. and above.
- 4.9.4 Necessary fitments and accessories shall be provided on motors in accordance with the latest Indian Electricity rules 1956.
- 4.9.5 All motors rated above 30 kW shall be provided with space heaters to maintain the motor internal air temperature above the dew point. Unless otherwise specified, space heaters shall be suitable for a supply of 240V AC, single phase, 50 Hz.
- 4.9.6 Name plate with all particulars as per IS: 325 shall be provided
- 4.9.7 Unless otherwise specified, the colour of finish shall be grey to Shade No. 631 and 632 as per IS:5 for motors installed indoor and outdoor respectively. The paint shall be epoxy based and shall be suitable for withstanding specified site conditions.

5.0 INSPECTION AND TESTING

- 5.1 All materials, components and equipments covered under this specification shall be procured, manufactured, as per the BHEL standard quality plan No. PED-506-00-Q-006/0 and PED-506-00-Q-007/2 enclosed with this specification and which shall be complied.
- 5.2 LV motors of type-tested design shall be provided. Valid type test reports not more than 5 year shall be furnished. In the absence of these, type tests shall have to be conducted by manufacturer without any commercial implication to purchaser.
- 5.3 All motors shall be subjected to routine tests as per IS: 325 and as per BHEL standard quality plan.
- 5.4 Motors shall also be subjected to additional tests, if any, as mentioned in Data Sheet A.

6.0 DRAWINGS TO BE SUBMITTED AFTER AWARD OF CONTRACT

- a) OGA drawing showing the position of terminal boxes, earthing connections etc.
- b) Arrangement drawing of terminal boxes.
- c) Characteristic curves:
(To be given for motor above 55 kW unless otherwise specified in Data Sheet).
 - i) Current vs. time at rated voltage and minimum starting voltage.
 - ii) Speed vs. time at rated voltage and minimum starting voltage.
 - iii) Torque vs. speed at rated voltage and minimum voltage.
For the motors with solid coupling the above curves i), ii), iii) to be furnished for the motors coupled with driven equipment. In case motor is coupled with mechanical equipment by fluid coupling, the above curves shall be furnished with and without coupling.
 - iv) Thermal withstand curve under hot and cold conditions at rated voltage and max. permissible voltage.

CLAUSE NO.	LT SWITCHGEAR (Starters Panel)
1.00.00	<p>CODES AND STANDARDS</p> <p>IEC 947, IS 13947</p>
2.00.00	<p>TYPE</p> <p>Circuit Breakers Shall be air break, three pole, spring charged, horizontal drawout type, suitable for electrical operation.</p> <p>Switchgear Fully drawout type single front</p> <p>MCC Fully drawout type single front/Double front.</p> <p>ACDB/DCDB Fixed type single front</p>
3.00.00	<p>SYSTEM PARAMETERS</p> <p>415VAC +/- 10 % (SOLIDLY GROUNDED)</p> <p>50 Hz +3%-5%</p> <p>45KA RMS / 1 SEC (FAULT LEVEL)</p> <p>220V DC NOMINAL (190V DC-240V DC) ISOLATED TYPE</p>
4.00.00	<p>TEMPERATURE RISE</p> <p>The temperature rise of the horizontal and vertical busbars and main bus link including all power drawout contacts when carrying 90% of the rated current along the full run shall in no case exceed 55 deg. C with silver plated joints and 40 deg. C with all other types of joints over an ambient of 50 deg C.</p>
5.00.00	<p>OPERATIONAL REQUIREMENTS</p>
5.01.00	<p>Breakers</p>
5.01.01	<p>Breakers shall have anti-pumping feature.</p>
5.01.02	<p>The incomer and bus coupler breakers for switchgear shall be electrically operated with over current releases or relays.</p>
5.01.03	<p>Breakers shall have inherent fault making and breaking capacities. They shall have shunt trip coils. In case releases are offered, the same shall have contact for energisation of lockout relay. All breakers shall have built in interlocks for equipment and personnel safety.</p>
5.01.04	<p>Paralleling of two supplies shall be avoided by interlocking except for switchgear where auto-changerover is provided. Breaker contact multiplication, if required, shall be through latch relay.</p>

CLAUSE NO.	LT SWITCHGEAR	
	(i) Front & Back	: RAL 9002
	(ii) Extreme end covers	: RAL 5012
7)	Busbars shall be of high conductivity aluminium alloy or copper.	
8)	Minimum air clearance in air between phases and phase-earth shall be 25 mm for busbars and cable terminations. For all other components, the Clearances shall be at least 10mm. Wherever above is not possible except for horizontal and vertical busbars, insulation shall be provided by anti tracking sleeving or barriers. However for horizontal and vertical busbars, clearances specified above shall be maintained even when busbars are insulated/sleeved. In case of DC DBs/ fuse boards, the busbar system shall be insulated or physically segregated with barriers to prevent interpole short circuit.	
9)	Busbar insulators shall be of track-resistant high strength non-hygroscopic, non-combustible type and suitable to withstand stresses due to over-voltages and short circuit current. Insulators and barrier of inflammable material such as Hylam shall not be accepted.	
10)	All types of relays and timer shall be subject to Employer's approval. They shall be flush mounted with connections from inside, and shall have transparent & dust tight cover, removable from front, drawout construction for easy replacement and testing facility. The auxiliary relays and timer may be provided in fixed cases.	
11)	Maxi terminal /cage clamp type terminal blocks shall be provided for signals to be interfaced with DDCMIS/PLC.	
12)	The switchgears/MCC shall be designed to offer adequate level of safety to operating/maintenance personnel. Means shall be provided to prevent access to the live part to avoid accidents during service as well as maintenance period. Bidder shall bring out the safety means provided to achieve above. A detailed instruction plate suitable for wall mounting shall be provided for each switchgear/MCC room describing various safe operating procedure/safety precautions for safe operation and maintenance of switchgear/MCC.	
13)	All current and voltage transformers as required for metering & protection specified shall be completely encapsulated, cast resin insulated type. Incomers from transformers shall have CTs for transformer REF protection. All current and voltage transformers as required for metering and protection specified shall be completely encapsulated, cast resin insulated type. Incomers from transformers shall have CTs for transformer restricted earth fault protection. The accuracy shall be as follows:	
	CTs	PTs
	Protection	3P
	Metering	10
	REF	PS

CLAUSE NO.	LT SWITCHGEAR
6.00.00	DESIGN AND CONSTRUCTIONAL FEATURES
6.01.00	<p>All 415V switch gear motor control centers (MCCs), AC & DC distribution boards (DBs), etc shall have following features :</p> <ol style="list-style-type: none"> 1) Shall be of metal enclosed, indoor, floor mounted and free standing type. 2) All frames and load bearing members shall be fabricated using mild steel structural sections or pressed and shaped cold rolled sheet steel of thickness not less than 2mm. 3) Frame shall be enclosed in cold rolled sheet steel of thickness not less than 1.6mm. Doors and covers shall also be of cold rolled sheet steel of thickness not less than 1.6 mm. Stiffeners shall be provided wherever necessary. Removable gland plates of thickness 3mm (hot/cold rolled sheet steel) or 4 mm (non-magnetic material) shall be provided for all panels. 4) All switchboards/panels shall be of dust and vermin proof. All cutouts shall have synthetic rubber gaskets. 5) For motors above 160kW, remote controlled electrical circuit breakers, and for smaller motors, switch-fuse contactor feeders shall be provided. The other outgoing feeders would be switch-fuse units or moulded case circuit breakers. 6) All switchboards, MCCs and DB s shall have following distinct vertical sections. <ol style="list-style-type: none"> a) Completely enclosed bus bar compartment for horizontal and vertical bus bars. b) Completely enclosed switchgear compartments (one for each circuit housing circuit breakers, motor starter or switch-fuse feeder). c) Compartment for cable alley or cable box for power and control cables In case of cable box, they shall be segregated with complete shrouding for individual feeders at the rear for direct termination of cables. d) For cable connection to circuit breaker, a separately enclosed cable compartment shall also be acceptable. e) Compartment for relays and other control devices associated with a circuit breaker, wherever necessary. f) The switchboards/MCC/DBs of 1600A & above rating shall be of DOP IP42 & of IP52 for less than 1600A rating g) All 415V switchgears, MCC's, AC & DC distribution boards etc. shall be painted by powder coating process. Paint shade shall be as follows

CLAUSE NO.	LT SWITCHGEAR
	<ul style="list-style-type: none"> f) hand reset lockout relay with a blue lamp for monitoring. 3) incomers/bus coupler/outgoing breaker feeders other than motor feeders <ul style="list-style-type: none"> a) Definite time delay short circuit protection b) Hand reset lockout relay with a blue lamp 4) Incomer From DG Set. <ul style="list-style-type: none"> a) Differential Protection (87) - Three Pole b) Reverse Power Protection. c) Overload Alarm on one phase d) Earth Fault Detection Relay (64) e) Voltage controlled overcurrent relay e) Generator under/over voltage Protection f) Hand Reset/Lockout Relay with a blue lamp. g) 3 Phase Energy Meter having accuracy of 1.0 class.
5.04.05	<p>Meters / instruments</p> <p>All meters/ instrument shall be flush mounted on front panel, at least 96 sq.mm. size with 90 degree linear scales and accuracy class of 2.0.</p>
5.04.06	<p>All motors of 30kW and above shall have an Ammeter. Bus-section shall have bus VT, voltmeter with selector switch, and other relay and timers required for protection. Adequate control and selector switches, push buttons and indicating lamps shall be provided. Thermostatically controlled space heaters with switches shall be provided to prevent condensation.</p>
5.04.07	<p>In case of remote controlled breaker panels, following shall be ensured.</p> <p>Each feeder shall have local/remote selector switch. Closing from local shall be possible only in test position whereas closing from remote shall be possible in either service or test position. Tripping from local shall be possible only when local/remote selector switch is in local position. Tripping from remote shall be either breaker in service position or selector switch being in remote position.</p>
05.00	<p>Control from Remote</p> <p>Necessary hardware shall be provided in the switchgear panel like coupling relays (24V DC, with max burden 2.5VA), auxiliary relays, current & voltage transducers (4-20 mA, dual output) etc. to effect interlocks, exchange information / status and exercise control from remote.</p>

CLAUSE NO.	LT SWITCHGEAR
	shall be made of minimum 3mm thick aluminium alloy. The section of the busduct should have adequate strength to withstand internal and external forces resulting from the various operating conditions. Aluminium sheet hood shall be provided for outdoor busduct enclosure joints to provide additional protection against water ingress. The busduct top shall be sloped to prevent retention of water. The busduct shall have DOP of IP55.
5.03.07	It should be possible to carryout maintenance on a feeder with adjacent feeders alive.
5.04.09	Control, Protection & Metering Requirements
5.04.01	Control circuits shall operate at suitable voltage of 110V AC or 220V DC. Necessary control supply transformers having primary and secondary fuses shall be provided for each MCC, 2 x 100% per section. However the breakers shall operate on 220V DC. The auxiliary bus bars for control supply shall be segregated from main bus bars. The control supplies shall be monitored.
5.04.02	Contractor shall fully co-ordinate overload and short circuit tripping of breaker with up-stream and down stream breakers/fuses/MCCBs motor starters. Various equipments shall meet requirement of Type-II class of coordination as per IEC.
5.04.03	All relays and timers shall operate on available DC supply and not have any inbuilt batteries. They shall be provided with hand-reset operation indicator (flags) or LEDs with pushbuttons for resetting.
5.04.04	All equipments shall have necessary protections. However, following minimum protections shall be provided:
	1) Contactor controlled motor feeders (Motors up to 160 kW)
	a) Instantaneous short circuit protection on all phases through HRC cartridge type fuses rated to: 80 kA rms (prospective breaking capacity at 415V).
	b) Thermal overload protection.
	c) Single phasing protection for motors protected by fuses.
	2) Breaker controlled motors feeders (motors rated above 160kW)
	a) Instantaneous short circuit protection on all phases
	b) Overload protection on two phases
	c) Over load alarm on third phase
	d) Earth fault protection
	e) Under voltage protection

CLAUSE NO.	LT SWITCHGEAR
01.05	Mechanical tripping shall be through red 'Trip' push button outside the panels for breakers, and through control switches for other circuits.
01.06	Provision of mechanical closing of breaker only in 'Test' and 'Withdrawn' position shall be made. Alternatively, mechanical closing facility should be normally inaccessible, accessibility rendered only after deliberate removal of shrouds. It shall be possible to close the door with breaker in test position.
01.07	Clear status indication for each circuit shall be provided through lamps, switch positions or other mechanical means.
01.08	Supervision relay shall be provided for trip coil monitoring.
03.00	Switches, Contactors and Fuses
02.01	Incomers for MCCs and DBs rated upto 630A could be load break isolators.
03.02	Motor starter contactors shall be of air break, electromagnetic type suitable for DOL starting of motor, and shall be of utilisation category AC-3 for ordinary and AC-4 for reversing starters. DC contactor shall be of DC-3 utilisation category.
03.03	Fuses shall be HRC type with operation indicator. Isolating switches shall be of AC 23A category when used in motor circuit, and AC 22A category for other applications. Fuse switch combination shall be provided wherever possible.
03.04	Isolating switches and MCCBs shall have door interlocks and padlocking facility.
	Panels
	All switchgears, MCCs, DBs, panels, modules, local starters and push buttons shall have prominent engraved identification plates.
02.02	Local push button stations shall have metal enclosure of die cast aluminium or rolled sheet steel of 1.6mm thickness & shall have DOP of IP-55. Push buttons shall be of latch type with mushroom knobs.
03.03	Where breaker/starter module front serves as compartment cover, suitable blanking covers, one for each size of modules per switchboard shall be supplied for use when carriage is withdrawn.
04.04	All non-current carrying metal work of boards/panels shall be effectively bonded to earth bus of galvanised steel, extending throughout the switchboard/MCC/DB. Positive earthing shall be maintained for all positions of chassis and breaker frame.
	Suitable trolley arrangement shall be provided for breaker/starter modules. Two trolleys per switchgear room shall be provided so that top most breaker module of all types, sizes and rating can be withdrawn on trolley and lowered for maintenance purpose.
	The incoming connection to transformer of more than 1000KVA and inter-connecting sections between switchboards shall preferably be of busducts. The busduct enclosure

		QUALITY PLAN		CUSTOMER :			PROJECT-2X660MW ENNORE TPP		SPECIFICATION :			
				BIDDER/ VENDOR :			TITLE		NUMBER :			
		SHEET 1 OF 2		SYSTEM			ITEM AC ELECT. MOTORS BELOW 55KW (LV)		SECTION		VOLUME III	
SL. NO.	COMPONENT/OPERATION	CHARACTERISTICS CHECK	CAT.	TYPE/METHOD OF CHECK	EXTENT OF CHECK	REFERENCE DOCUMENT	ACCEPTANCE NORM	FORMAT OF RECORD	AGENCY			REMARKS
									P	W	V	
1	2	3	4	5	6	7	8	9	10			11
1.0	ASSEMBLY	1.WORKMANSHIP	MA	VISUAL	100%	MANUF'S SPEC	MANUF'S SPEC	-DO-	2	-	-	
		2.DIMENSIONS	MA	-DO-	-DO-	MFG. DRG./ MFG. SPEC.	MFG. DRG./ MFG. SPEC.	-DO-	2	-	-	
		3.CORRECTNESS COMPLETENESS TERMINATIONS/ MARKING/COLOUR CODE	MA	VISUAL	100%	MFG.SPEC./ RELEVANT IS	MFG.SPEC. RELEVANT IS	-DO-	2	-	-	
2.0	PAINTING	1.SHADE	MA	VISUAL	SAMPLE	MANUFR'S SPEC/BHEL SPEC./RELEVANT STANDARD	BHEL SPEC. SAME AS COL.7	LOG BOOK	2	-	-	
3.0	TESTS	1.ROUTINE TEST INCLUDING SPECIAL TEST AS PER BHEL SPEC.	MA	-DO-	100%	IS-325/ BHEL SPEC./ DATA SHEET	SAME AS COL.7	TEST REPORT	2	1	-	NOTE -1 & NOTE-3
		2.OVERALL DIMENSIONS & ORIENTATION	MA	MEASUREMENT & VISUAL	100%	APPROVED DRG/DATA SHEET	APPROVED DRG/DATA SHEET & RELEVANT IS	INSPN. REPORT	2	1	-	NOTE -1 & NOTE-3
BHEL			PARTICULARS			BIDDER/VENDOR						
			NAME									
			SIGNATURE									



QUALITY PLAN

CUSTOMER :

PROJECT-2X660MW ENNORE TPP

SPECIFICATION :

BIDDER/ :

TITLE

NUMBER :

VENDOR

QUALITY PLAN
NUMBER PED-506-00-Q-006, REV-01

SPECIFICATION :

SHEET 2 OF 2

SYSTEM

ITEM AC ELECT. MOTORS BELOW 55KW (LV)

SECTION

VOLUME III

SL. NO.	COMPONENT/OPERATION	CHARACTERISTICS CHECK	CAT.	TYPE/METHOD OF CHECK	EXTENT OF CHECK	REFERENCE DOCUMENT	ACCEPTANCE NORM	FORMAT OF RECORD	AGENCY			REMARKS
									P	W	V	
1	2	3	4	5	6	7	8	9	10			11
		3.NAMEPLATE DETAILS	MA	VISUAL	100%	IS-325 & DATA SHEET	IS-325 & DATA SHEET	INSPN. REPORT	2	1	-	
<p>NOTES:</p> <p>1 ROUTINE TESTS ON 100% MOTORS SHALL BE DONE BY THE VENDOR. HOWEVER, BHEL SHALL WITNESS ROUTINE TESTS ON RANDOM SAMPLES. THE SAMPLING PLAN SHALL BE MUTUALLY AGREED UPON</p> <p>2 WHERE EVER CUSTOMER IS INVOLVED IN INSPECTION, (1) SHALL MEAN BHEL AND CUSTOMERS BOTH TOGETHER.</p> <p>3 FOR EXHAUST/VENTILATION FAN MOTORS OF RATING UPTO 1.5KW , ONLY ROUTINE TEST CERTIFICATES SHALL BE FURNISHED FOR SCRUTINY.</p> <p><u>Legends for Inspection agency</u></p> <p>1. BHEL/CUSTOMER 2. VENDOR (MOTOR MANUFACTURER) 3. SUB-VENDOR (RAW MATERIAL/COMPONENTS SUPPLIER)</p> <p>P. PERFORM W. WITNESS V. VERIFY</p>												
BHEL			PARTICULARS			BIDDER/VENDOR						
			NAME									
			SIGNATURE									
			DATE						BIDDER'S/VENDORS COMPANY SEAL			



TITLE : TECHNICAL SPECIFICATION
FOR
SELF CLEANING STRAINERS

SPEC. NO. PE-TS- 412-165-N003

VOLUME : IIB

SECTION : C

REV. NO. 0

DATE :
16.06.15

SHEET 1 of 1

SECTION D3
STANDARD TECHNICAL SPECIFICATION
FOR
C&I SYSTEMS



**Data Sheet
FOR
MOTORISED VALVE ACTUATOR**

SPECIFICATION NO.: PE-ID-412-145-I902

VOLUME II B

SECTION D

REV. NO. 00

DATE: 18.05.15

SHEET 1

OF 3

Data Sheet A & B

DATA SHEET-A
(TO BE FILLED BY PURCHASER)

DATA SHEET-B
(TO BE FILLED-UP BY BIDDER)

GENERAL*	* PROJECT	2x 660 MW ENNORE STP		
	OFFER REFERENCE			
	* TAG NO. SERVICE			
	* DUTY	<input type="checkbox"/> ON / OFF	<input type="checkbox"/> INCHING	
	* LINE SIZE (inlet/outlet): MATERIAL			
	* VALVE TYPE	<input type="checkbox"/> GLOBE <input type="checkbox"/> GATE <input type="checkbox"/> REG. GLOBE <input type="checkbox"/> BUTTERFLY		
	* OPENING / CLOSING TIME			
	* WORKING PRESSURE			
	AMBIENT CONDITION	SHALL BE SUITABLE FOR CONTINUOUS OPERATION UNDER AN AMBIENT TEMP. OF 0-55 DEG C AND RELATIVE HUMIDITY OF 0-95%		
	VALVE SEAT TEST PRESS	BIDDER TO SPECIFY		
	REQUIRED VALVE TORQUE	BIDDER TO SPECIFY		
	ACTUATOR RATED TORQUE	BIDDER TO SPECIFY		
CONSTRUCTION AND SIZING	CONSTRUCTION	TOTALLY ENCLOSED, WEATHER PROOF, IP:68		
	MECHANICAL POSITION INDICATOR	TO BE PROVIDED FOR 0-100% TRAVEL		
	BEARINGS	DOUBLE SHIELDED, GREASE LUBRICATED ANTI-FRICTION.		
	GEAR TRAIN FOR LIMIT SWITCH/TORQUE SWITCH OPERATION	METAL (NOT FIBRE GEARS). SELF-LOCKING TO PREVENT DRIFT UNDER TORQUE SWITCH SPRING PRESSURE WHEN MOTOR IS DE-ENERGIZED.		
	SIZING	OPEN/CLOSE AT RATED SPEED AGAINST DESIGNED DIFFERENTIAL PRESSURE AT 85% OF RATED VOLTAGE. FOR ISOLATING SERVICE THREE SUCCESSIVE OPEN-CLOSE OPERATIONS OR 15 MINS. WHICHEVER IS HIGHER. FOR INCHING SERVICE - 150 STARTS/HR MINIMUM & FOR REGULATING SERVICE - 600 STARTS/HR MINIMUM.		
HANDWHEEL	* REQUIRED	<input checked="" type="checkbox"/> YES <input type="checkbox"/> NO		
	* ORIENTATION	<input type="checkbox"/> TOP MOUNTED <input type="checkbox"/> SIDE MOUNTED		
	*TO DISENGAGE AUTOMATICALLY DURING MOTOR OPERATION.			
ELECTRIC ACTUATOR	ACTUATOR MAKE/MODEL	BIDDER TO SPECIFY		
	MOTOR MAKE / MODEL / TYPE / RATING (KW)	BIDDER TO SPECIFY		
	@ MOTOR TYPE	SQUIRREL CAGE INDUCTION MOTOR, STARTING CURRENT LIMITED TO SIX TIMES THE RATED CURRENT- INCLUSIVE OF I.S. TOLERANCE		
	ACTUATOR APPLICABLE WIRING DIAGRAM	<input type="checkbox"/> ENCLOSED (BIDDER TO CONFIRM) A: <input type="checkbox"/> DRG. NO. 3-V-MISC-24227 R00 B: <input type="checkbox"/> DRG. NO. 3-V-MISC-24550 R00 C: <input type="checkbox"/> DRG. NO. 3-V-MISC-24283 R00 D: <input type="checkbox"/> DRG. NO. 4-V-MISC-90271 R11 E: <input type="checkbox"/> For Thyristor based Integral starter, Bidder/Vendor to furnish wiring diagram		
	COLOUR SHADE	<input type="checkbox"/> BLUE (RAL 5012) <input type="checkbox"/> DURING DETAIL ENGG.		
	PAINT TYPE (## Refer Notes)	<input type="checkbox"/> ENAMEL <input checked="" type="checkbox"/> EPOXY <input type="checkbox"/>		
	SHAFT RPM	BIDDER TO SPECIFY		
	OLR SET VALUE	BIDDER TO SPECIFY		
	@ STARTING / FULL LOAD CURRENT	BIDDER TO SPECIFY		
	NO. OF REV FOR FULL TRAVEL	BIDDER TO SPECIFY		
	@ PWR SUPP TO MTR / STARTER	415V, 3PH, AC		
	@ CONTROL VOLTAGE REQUIREMENT	TO BE DERIVED FROM THE POWER SUPPLY TO THE STARTER <input type="checkbox"/> 230 V <input type="checkbox"/> 110 V		

	Data Sheet FOR MOTORISED VALVE ACTUATOR		SPECIFICATION NO.: PE-ID-412-145-I902			
			VOLUME		II B	
			SECTION		D	
			REV. NO.	00	DATE: 18.05.15	
			SHEET	2	OF	3
Data Sheet A & B						
DATA SHEET-A (TO BE FILLED BY PURCHASER)			DATA SHEET-B (TO BE FILLED-UP BY BIDDER)			
	@ ENCLOSURE CLASS OF MOTOR	<input checked="" type="checkbox"/> IP 68 <input type="checkbox"/> FLAME PROOF				
	@ INSULATION CLASS	CLASS-F TEMP. RISE LIMITED TO CLASS-B				
	@ WINDING TEMP PROTECTION	<input checked="" type="checkbox"/> THERMOSTAT (3 Nos.,1 IN EACH PHASE) <input type="checkbox"/>				
	SINGLE PHASE / WRONG PHASE SEQUENCE PROTECTION	REQUIRED				
INTEGRAL STARTER	INTEGRAL STARTER	<input checked="" type="checkbox"/> REQUIRED <input type="checkbox"/> NOT REQUIRED				
	TYPE OF SWITCHING DEVICE	<input checked="" type="checkbox"/> CONTACTORS <input type="checkbox"/> THYRISTORS				
	TYPE	<input checked="" type="checkbox"/> CONVENTIONAL <input type="checkbox"/> SMART (NON-INTRUSIVE)				
	STEP DOWN CONT. TRANSFORMER	<input checked="" type="checkbox"/> REQUIRED				
	OPEN / CLOSE PB	<input checked="" type="checkbox"/> REQUIRED <input type="checkbox"/> NOT REQUIRED				
	STOP PB	<input checked="" type="checkbox"/> REQUIRED <input type="checkbox"/> NOT REQUIRED				
	INDICATING LAMPS	<input checked="" type="checkbox"/> REQUIRED <input type="checkbox"/> NOT REQUIRED				
	LOCAL REMOTE S/S	<input checked="" type="checkbox"/> REQUIRED <input type="checkbox"/> NOT REQUIRED				
	STATUS CONTACTS FOR MONITORING	<input checked="" type="checkbox"/> REQUIRED <input type="checkbox"/> NOT REQUIRED				
INTEGRAL STARTER DISTURBED SIGNAL	REQUIRED (MOTOR THERMOSTAT TRIP, O/L RELAY OPERATED, CONT./POWER SUPPLY FAILED, PHASE LOSS, S/S IN LOCAL/OFF MODE, STOP PB OPTD,TORQUE OPEN/CLOSE CUTOFF)					
INTERPOSING RELAY/OPTO COUPLER (Applicable for integral Starter)	TYPE OF ISOLATING DEVICE	<input type="checkbox"/> INTERPOSING RELAY <input type="checkbox"/> OPTO COUPLER <input type="checkbox"/> EITHER				
	QUANTITY	<input checked="" type="checkbox"/> 2 NOs. <input type="checkbox"/> 3 NOs.				
	DRIVING VOLTAGE	<input checked="" type="checkbox"/> 20.5 – 24V DC <input type="checkbox"/> _____ V DC				
	DRIVING CURRENT	<input checked="" type="checkbox"/> 125mA MAX <input type="checkbox"/> _____ mA MAX				
	LOAD RESISTANCE	<input checked="" type="checkbox"/> > 192 ohms - <25 k ohms <input type="checkbox"/> > _____ ohms - < _____ ohms				
	NO. OF IPR CONTACT(in case of IPR)	2 SETS SILVER PLATED CHANGEOVER CONTACT				
	IPR CONTACT VALUE (in case of IPR)	0.5A/220V DC or 8A/ 240V AC				
	IPR FEATURE (in case of IPR)	a) FREE WHEELING DIODE AND SELF RESET TYPE STATUS INDICATOR b) MANUAL FORCING/ OVERIDING FACILITY				
TORQUE SWITCH (Not Applicable for Smart Actuator) (\$\$ Refer Notes)	MFR & MODEL NO.	BIDDER TO SPECIFY				
	OPEN / CLOSE	<input checked="" type="checkbox"/> 1 No. <input type="checkbox"/> 2Nos. / <input checked="" type="checkbox"/> 1 No. <input type="checkbox"/> 2Nos				
	CONTACT TYPE	2 NO + 2 NC				
	RATING	5A 240V AC AND 0.5A 220V DC				
	CALIBRATED KNOBS(OPEN&CLOSE TS)	REQUIRED FOR SETTING DESIRED TORQUE				
	ACCURACY	+3% OF SET VALUE				
LIMIT SWITCH (Not Applicable for Smart Actuator) (\$\$ Refer Notes)	MFR & MODEL NO.	BIDDER TO SPECIFY				
	OPEN : INT : CLOSE	<input type="checkbox"/> 1 No <input checked="" type="checkbox"/> 2 Nos.	2 Nos. (ADJ.)	<input type="checkbox"/> 1 No. <input checked="" type="checkbox"/> 2Nos.		
	CONTACT TYPE	2 NO + 2 NC				
	RATING (AC / DC)	5A 240V AC AND 0.5A 220V DC				



**Data Sheet
FOR
MOTORISED VALVE ACTUATOR**

SPECIFICATION NO.: PE-ID-412-145-I902

VOLUME II B

SECTION D

REV. NO. 00

DATE: 18.05.15

SHEET 3

OF 3

Data Sheet A & B

DATA SHEET-A
(TO BE FILLED BY PURCHASER)

DATA SHEET-B
(TO BE FILLED-UP BY BIDDER)

POSITION TRANSMITTER	POSITION TRANSMITTER (For inching duty & other specific applications)	<input checked="" type="checkbox"/> REQUIRED <input type="checkbox"/> NOT REQUIRED	
	MFR & MODEL NO.	BIDDER TO SPECIFY	
	TYPE	<input type="checkbox"/> ELECTRONIC (2 WIRE) R/I CONVERTER <input checked="" type="checkbox"/> ELECTRONIC (2 WIRE) CONTACTLESS	
	SUPPLY	<input checked="" type="checkbox"/> 24V DC <input type="checkbox"/>	
	OUTPUT	<input checked="" type="checkbox"/> 4-20mA	
	ACCURACY	$\pm 1\%$ FS	
SPACE HEATER	@SPACE HEATER	REQUIRED	
	@ POWER SUPPLY (NON INTEGRAL)	230V AC, 1 PH., 50 Hz	
	@ POWER SUPPLY (INTEGRAL)	BIDDER TO SPECIFY	
	@ RATING		
TERMINAL BOX	ACTUATOR/MOTOR TERMINAL BOX	REQUIRED	
	ENCL CLASS ACTUATOR/MOTOR T.B.	@ <input checked="" type="checkbox"/> IP 68 @ <input type="checkbox"/>	
	@ EARTHING TERMINAL	REQUIRED	
	PLUG & SOCKET (9 PIN) (FOR COMMD, LS/TS FEED BACK, PoT)	<input type="checkbox"/> REQUIRED <input checked="" type="checkbox"/> NOT REQUIRED <input type="checkbox"/> 2 NOS. <input type="checkbox"/>	
CABLE GLANDS	@ POWER CABLE GLAND	SIZE:.....	
	@ SPACE HEATER CABLE GLAND	SIZE:.....	
	OTHER CONTROL CABLE GLANDS	QUANTITY & SIZE :Cable gland suitable for 8Px0.5 sq mm & 2P x 0.5 sq mm Cable.	
WEIGHT	TOTAL WEIGHT (ACTUATOR + ACCESSORIES)	BIDDER TO SPECIFY	_____ Kg.

NOTES:

- SCOPE:** DESIGN, MANUFACTURE, INSPECTION, TESTING AND DELIVERY TO SITE OF ELECTRIC ACTUATOR FOR INCHING OR OPEN / CLOSE DUTY.
- CODES & STANDARDS:** DESIGN AND MATERIALS USED SHALL COMPLY WITH THE RELEVANT LATEST NATIONAL AND INTERNATIONAL STANDARD. AS A MINIMUM, THE FOLLOWING STANDARDS SHALL BE COMPLIED WITH:
IS-9334, IS-2147, IS-2148, IS-325, IS-2959, IS-4691 AND IS-4722
- ACTUATOR SHALL HAVE HARDWIRED CONTACTS FOR FOLLOWING SIGNALS (a) ACTUATOR IN LOCAL MODE (b) ACTUATOR IN REMOTE MODE.
- ACTUATOR SHALL INCLUDE A DIGITAL POSITION INDICATOR WITH A DISPLAY FROM FULLY OPEN TO FULLY CLOSE IN 1% INCREMENTS.
- BIDDER TO ENSURE AVAILABILITY OF SPARE 1NO + 1NC LIMIT SWITCH & TORQUE SWITCH.
- SS TAG NAME PLATE SHALL BE PROVIDED.
- TEMPERATURE RISE SHALL BE RESTRICTED TO 70 DEG. C FOR AMBIENT TEMPERATURE OF 50 DEG C.
- CABLE GLANDS OF DOUBLE COMPRESSION TYPE, Ni PLATED BRASS MATERIAL SHALL BE PROVIDED.
- THE TORQUE SWITCHES SHALL BE PROVIDED WITH MECHANICAL LATCHING DEVICE TO PREVENT OPERATION WHEN UNSEATING FROM THE END POSITIONS. THE LATCHING DEVICE SHALL UNLATCH AS SOON AS THE VALVE LEAVES THE END POSITION. IF SUCH PROVISION IS NOT POSSIBLE, THE TORQUE SWITCHES SHALL BE BYPASSED BY END-POSITION LIMIT SWITCHES WHICH OPENS ON VALVE LEAVING END POSITION. THESE LIMIT SWITCHES ARE ADDITIONAL TO THE NUMBER OF LIMIT SWITCHES SPECIFIED ELSEWHERE.
- THE MOTOR SHALL OPERATE SATISFACTORILY UNDER THE +/- 10% SUPPLY VOLTAGE VARIATION AT RATED FREQUENCY, -5% TO +3% VARIATION IN FREQUENCY AT RATED SUPPLY VOLTAGE, SIMULTANEOUS VARIATION IN VOLTAGE & FREQUENCY THE SUM OF ABSOLUTE PERCENTAGE NOT EXCEEDING 10%.
- THE MOTOR SHALL BE SUITABLE FOR DIRECT ON LINE STARTING.

\$\$ TORQUE SWITCH & LIMIT SWITCH SHALL ACT INDEPENDENT OF EACH OTHER. TANDEM OPERATION IS NOT ACCEPTABLE.

EPOXY PAINT IS RECOMMENDED FOR COASTAL AREAS.

NOTES* = TO BE FILLED BY MPL (LEAD AGENCY). @ = TO BE FILLED BY ES

	CHECK LIST FOR	SPECIFICATION NO.:	
	PRESSURE / DIFFERENTIAL PRESSURE TRANSMITTER	VOLUME	
	(Mechanical Auxilliary Packages)	SECTION	
		REV. NO.	DATE:
		SHEET <u>3</u> OF <u>3</u>	
Data Sheet No.: PE-CL-999-145-1026-0			

SL NO	TESTS/CHECKS	QUANTM OF CHECK	REFERENCE DOC. ACCEPTANCE NORMS	AGENCY			REMARKS
				M	C	B	
1.0	CHECKS FOR VISUAL, MODEL TAG NO.	SEE NOTE-1 BELOW	APPROVED TECHINCAL REQUIREMENT/ DATA SHEET	P	W	V	MFR TO CARRY OUT ROUTINE TEST ON 100%. WHEN MATERIAL CORELATION ARE NOT AVAILABLE MFR'S COMPLIANCE TO BE PROVIDED
2.0	PROCESS CONNECTION	-do-		P	W	V	
3.0	ACCURACY	-do-		P	W	V	
4.0	REPEATEABILITY	-do-		P	W	V	
5.0	HYSTERISIS	-do-		P	W	V	
6.0	EFFECT OF TEMP VARIATION ON ACCURACY	-do-		P	W	V	
7.0	SPAN /ZERO ADJUSTMENT	ONE/TYPE		P	W	V	
8.0	EFFECT OF SUPPLY VOLTAGE VARIATION	ONE/TYPE		P	W	V	
9.0	HIGH PRESSURE TEST	SEE NOTE-1 BELOW		P	W	V	
10.0	BURN IN TEST	ONE/TYPE		P	W	V	
11.0	DEGREE OF PROTECTION	ONE/TYPE		P	W	V	

LEGEND:

M: MANUFACTURER/ SUB CONTRACTOR, C: CONTRACTOR/ NOMINATED INSP AGENCY, B: BHEL. P: PERFORM, W: WITNESS, V: VERIFICATION.

NOTE:

1. QUANTUM OF CHECK SHALL BE AS BELOW
100 % - BY MANUFACTURER
RANDOM FOR EACH TYPE - BY BHEL & CUSTOMER
2. MANUFACTURER TO MAINTAIN CALIBRATED INSTRUMENT HAVING BETTER ACCURACY THAN THE ITEM UNDER TEST. INSPECTING ENGINEER SHALL CHECK THE SAME.
3. IN CASE OF IMPORTED ITEMS CONTRACTORS SHALL REVIEW TC's AND NOT INSPECT.

CONTRACTOR TO PROVIDE COMPLIANCE CERTIFICATE FOR TESTS/CHECKS VERIFIED BY CONTRACTOR AND SUBMIT THE SAME ALONGWITH TEST CERTIFICATES TO BE VERIFIED BY BHEL.



**CHECK LIST FOR
PRESSURE / DIFFERENTIAL PRESSURE GAUGE
(Mechanical Auxiliary Packages)**

SPECIFICATION NO.: /	
VOLUME	
SECTION	
REV. NO.	DATE:
SHEET 2	OF 2

Data Sheet No.: PE-CL-999-145-1026-0

SL NO	TESTS/CHECKS	QUANTM OF CHECK	REFERENCE DOC. ACCEPTANCE NORMS	AGENCY			REMARKS
				P	W	V	
1.0	CHECK FOR		APPROVED TECHNICAL REQUIREMENT/ DATA SHEET				MFR TO CARRY OUT ROUTINE TEST ON 100%. WHEN MATL CORELATION ARE NOT AVAILABLE MFR'S COMPLIANCE TO BE PROVIDED
	1.1 DIAL SIZE	100%		M	C	C	
	1.2 MODEL NO/TAG NO	100%		M	C	C	
	1.3 RANGE/SCALE	100%		M	C	C	
	1.4 END CONNECTION	100%		M	C	C	
	1.5 SWITCH CONTACT RATING & NOS	100%		M	C	C	
2.0	CALIBRATION						
	2.1 ACCURACY	100%		M	C	B	
	2.2 REPEATABILITY (FOR SWITCH)	100%		M	C	B	
	2.3 SET POINT ADJUSTMENT FOR SWITCH	100%		M	C	C	
3.0	OVER PRESSURE & LEAK TEST	100%	M	C	C		
4.0	OPERATION OF PR. RELIEF DEVICE	ONE PER TYPE	M	C	C		
5.0	REVIEW OF T.C. FOR MATERIAL OF--						
	5.1 SENSOR	FOR LOT	-	-	B		
	5.2 MOVEMENT		-	-	B		
	5.3 PROCESS CONNECTION		-	-	B		
	5.4 HOUSING		-	-	B		
6.0	REVIEW OF T.C. FOR DEGREE OF PROTECTION	TYPE TEST	-	-	B		
7.0	REVIEW OF T.C. FOR CONTACT RATING OF SWITCH	ONE PER TYPE	-	-	B		
8.0	ACCESSORIES AS APPLICABLE	100%	M	C	C		

LEGEND:

M: MANUFACTURER/ SUB CONTRACTOR, C: CONTRACTOR/ NOMINATED INSP AGENCY, B: BHEL. P: PERFORM, W: WITNESS, V: VERIFICATION.

NOTE:

CONTRACTOR TO PROVIDE COMPLIANCE CERTIFICATE FOR TESTS/CHECKS VERIFIED BY CONTRACTOR AND SUBMIT THE SAME ALONGWITH TEST CERTIFICATES TO BE VERIFIED BY BHEL.