

TENDER ENQUIRY

Volume – IA: Technical Bid

Dear Sir,

Sealed offers are invited by the undersigned on behalf of BHARAT HEAVY ELECTRICALS LIMITED for the subject job. Please find enclosed tender documents as per following details:

Tender No: 1406070 Date 25-11-2014 comprising of following:

Salient Details of NIT		
S. No.	Issue	Description
1.0	Supply Description	Supply of Differential Pressure Transmitter, Pressure Transmitter and HART Communicator as per Technical Specifications to BHEL-PSWR, PSNR, PSER & PSSR.
2.0	Enquiry No	1406070
3.0	Details of Tender Document	
3.1	Volume - I A	Technical Bid – (Pre-Qualification Criteria & Technical Specification)
3.2	Volume - I B	General Conditions of the Contract
3.3	Volume – II	Price Bid
4.0	Tender Due Date	Last date of submission of offer is 09-12-2014 Time: 15.00 Hrs. Opening of Tender 09-12-2014 Time: 15.30 Hrs. Notes: (1) In case the due date of opening of tender becomes a non-working day, then the due date & time of offer submission and opening of tenders get extended to the next working day. (2) Bidder may depute representative to witness the opening of tender

The offer shall be submitted as per the instructions of tender document and as detailed in this NIT. Bidders to note specifically that all pages of tender document, including these NIT pages of this particular tender together with subsequent correspondences shall be submitted by them, duly signed & stamped on each page, as part of offer. Rates/Price including discounts/rebates, if any, mentioned anywhere/in any form in the techno-commercial offer other than the Price Bid shall not be entertained.

**BHARAT HEAVY ELECTRICALS LIMITED
POWER SECTOR WESTERN REGION, NAGPUR**

ENQUIRY NO. 1406070

DT.25.11.14

DUE DATE: 09.12.14

Complete set of offer shall be sent to BHEL PSWR, Nagpur as per address given below as per following details.

I. Procedure for Submission of Tenders:

a) COVER-I (TECHNO-COMMERCIAL BID) – in sealed envelope	
1.	Offer forwarding/covering letter of the Tenderer
2.	Duly filled-in 'No deviation certificate' as per prescribed format. In case of any deviation, the same should be submitted separately for technical & commercial parts, indicating respective clauses of tender against which deviation is taken by bidder. It shall be specifically noted that deviation recorded elsewhere shall not be entertained.
3.	Techno-commercial offer enclosing supporting documents meeting Pre Qualifying Criteria / annexures / schedules etc. as required in line with prescribed format. It shall be specifically noted that all documents as per above shall be indexed properly.
4.	All volumes of tender document pertinent for the subject job including NIT together with subsequent changes in the tender, correspondences etc., signed on all pages.
b) COVER-II (PRICE BID) – in sealed envelope	
c) COVER-III All three aforesaid covers in sealed condition shall be enclosed in this cover. All covers shall be super-scribed with i. Cover No. ii. Name of the job, tender document no. & due date of submission. ALONG WITH NAME & COMPLETE ADDRESS (FAX NO. CONTACT NOS) OF BIDDER and should be addressed to: AGM / Purchase Bharat Heavy Electricals Limited PSWR Shree Mohini Complex, 5 th Floor 345 Kingsway, Nagpur – 440001 Maharashtra	

**BHARAT HEAVY ELECTRICALS LIMITED
POWER SECTOR WESTERN REGION, NAGPUR**

ENQUIRY NO. 1406070

DT.25.11.14

DUE DATE: 09.12.14

SPECIAL NOTE:

1. Bidders' offer documents shall be paginated, signed and stamped in each page by your authorized representative. No overwriting / correction in tender documents by bidders shall be allowed. However, if correction is unavoidable, the same may be signed by authorized signatory.

All documents / annexure submitted with the offer shall be properly annexed and placed in respective places of the offer as per enclosure list mentioned in the covering letter. BHEL shall not be responsible for any missing documents.

2. BHEL reserves the right to accept or reject any or all Offers without assigning any reasons thereof. BHEL also reserves the right to cancel the Tender wholly or partly without assigning any reason thereof. Also BHEL shall not entertain any correspondence from bidders in this matter.

3. BHEL also reserve the right to reject the bidder with unsatisfactory past performance in the execution of a contract. BHEL's decision in this regard shall be final & binding.

4. For any clarification on the tender document, you may seek the same in writing from the office of the undersigned. Such letters should reach the office of the under signed positively by 11-09-2014.

5. Price bids of those bidders will be opened who will be qualified for the subject job on the basis of evaluation of Techno-commercial bids / pre-qualifying criteria and as considered suitable by BHEL.

6. While BHEL reserves the right to open the price bid of the offers in camera, the date & time to open the tender opening shall be intimated to the bidders in case BHEL decides it to be 'Public opening' and in such a case, one authorized representative of the bidder shall be allowed to attend.

7. Order of Precedence

In the event of any ambiguity or conflict between the Tender Documents, the order of precedence shall be in the order below:

- a. Amendments/Clarifications/Corrigenda/Errata etc. issued in respect of the tender documents by BHEL
- b. Notice Inviting Tender (NIT)
- c. Price Bid – Volume - II
- d. Technical Conditions of Contract (TCC)—Volume-1A
- e. General Conditions of Contract (GCC) —Volume-1B

It may please be noted that guidelines/rules in respect of suspension of business dealings', 'Vendor evaluation format' etc. may undergo change from time to time and the latest one shall be followed.

Thanking you,

For Bharat Heavy Electricals Ltd

AGM/Purchase

**BHARAT HEAVY ELECTRICALS LIMITED
POWER SECTOR WESTERN REGION, NAGPUR**

ENQUIRY NO. 1406070

DT.25.11.14

DUE DATE: 09.12.14

Reverse Auction Terms & Conditions

Against this enquiry for the subject item/ system with detailed scope of supply as per enquiry specifications, BHEL may resort to "REVERSE AUCTION PROCEDURE" i.e., ON LINE BIDDING (THROUGH A SERVICE PROVIDER) in event of at least four techno-commercially qualified bidders. The philosophy followed for reverse auction shall be English Reverse (No ties). For the proposed reverse auction, technically and commercially acceptable bidders only shall be eligible to participate.

1. For the proposed reverse auction, technically and commercially acceptable bidders only shall be eligible to participate.
2. Those bidders who have given their acceptance for Reverse Auction (quoted against this tender enquiry) will have to necessarily submit 'online sealed bid' in the Reverse Auction. Non-submission of 'online sealed bid' by the bidder for any of the eligible items for which techno-commercially qualified, will be considered as tampering of the tender process and will invite action by BHEL as per extant guidelines in vogue.
3. BHEL will engage the services of a service provider who will provide all necessary training and assistance before commencement of on line bidding on internet.
4. In case of reverse auction, BHEL will inform the bidders the details of Service Provider to enable them to contact & get trained.
5. Business rules like event date, time, bid decrement, extension etc. also will be communicated through service provider for compliance.
6. Bidders have to fax the Compliance form (annexure IV) before start of Reverse auction. Without this, the bidder will not be eligible to participate in the event.
7. In line with the NIT terms, BHEL will provide the calculation sheet if applicable (e.g., EXCEL sheet), which will help to arrive at "Total Cost to BHEL" like Packing & forwarding charges, Taxes and Duties, Freight charges, Insurance, Service Tax for Services and loading factors (for non-compliance to BHEL standard Commercial terms & conditions) for each of the bidder to enable them to fill-in the price and keep it ready for keying in during the Auction.
8. Reverse auction will be conducted on scheduled date & time.
9. At the end of Reverse Auction event, the lowest bidder value will be known on auction portal.
10. The lowest bidder has to fax/e-mail the duly signed and filled-in prescribed format for price breakup including that of line items, if required, (Annexure VII) as provided on case-to-case basis to Service provider within two working days of Auction without fail.
11. In case BHEL decides not to go for Reverse Auction procedure for this tender enquiry, the Price bids and price impacts, if any, already submitted and available with BHEL shall be opened as per BHEL's standard practice.
12. Bidders shall be required to read the "Terms and Conditions" section of the auctions site of Service provider, using the Login IDs and passwords given to them by the service provider before reverse auction event. Bidders should acquaint themselves of the "Business Rules of Reverse Auction", which will be communicated before the Reverse Auction.
13. If the Bidder or any of his representatives are found to be involved in Price manipulation/ cartel formation of any kind, directly or indirectly by communicating with other bidders, action *as per extant BHEL guidelines*, shall be initiated by BHEL and the results of the RA scrapped/ aborted.
14. The Bidder shall not divulge either his Bids or any other exclusive details of BHEL to any other party.
15. In case BHEL decides to go for reverse auction, the H1 bidder (whose quote is highest in online sealed bid) may not be allowed to participate in further RA process.

**BHARAT HEAVY ELECTRICALS LIMITED
POWER SECTOR WESTERN REGION, NAGPUR**

ENQUIRY NO. 1406070

DT.25.11.14

DUE DATE: 09.12.14

II. Pre-Qualification Criteria

QUALIFICATION REQUIREMENT FOR DP TRANSMITTERS, PRESSURE TRANSMITTERS & HART COMMUNICATOR			
S. NO	PRE QUALIFICATION CRITERIA	Bidders claim in respect of fulfilling the PQR Criteria	
		Name and Description of qualifying criteria	Page no of supporting document.
A	<p><u>Technical</u></p> <p>Bidder must be manufacturer and have executed following works in the last TWO (2) years as on latest date of bid submission:-</p> <p>A.1) Bidder must have supplied DP Transmitter and/or Pressure Transmitter worth of Rs.60 Lakhs or more in a maximum of two purchase orders (to any Government, Semi Government/ or any Customer).</p>	APPLICABLE	
B-1	<p><u>Financial Turnover:</u></p> <p>Bidders must have achieved an average annual financial turnover (Audited) of Rs.65 Lakhs or more over last three Financial Years (FY) i.e. 2011-12, 2012-13, 2013-14 if 2013-14 is audited or 2010-2011, 2011-2012, 2012-2013 if Annual Accounts for FY 2013-14 are not audited.</p>	APPLICABLE	
B-2	<p><u>NETWORTH (only in case of Companies)</u></p> <p>Net worth of the Bidder based on the latest Audited Accounts as furnished for 'B-1' above should be positive</p>	APPLICABLE	
B-3	<p><u>PROFIT</u></p> <p>Bidder must have earned cash profit in any one of the three Financial Years as applicable in the last three Financial Years defined in 'B-1' above based on latest Audited Accounts.</p>	APPLICABLE	
C	<p><u>Price Bid Opening</u></p> <p>Note: Price Bids of only those bidders shall be opened who stand qualified after compliance of criteria A to B.</p>	APPLICABLE	BY BHEL

Explanatory Notes for QR

- A. Bidder to submit Audited Balance Sheet and Profit and Loss Account for the respective years as indicated against B-1 above along with all annexures
- B. In case audited financial statements have not been submitted for all the three years as indicated against B-1 above, then the applicable audited statements submitted by the bidders against the requisite three years, will be averaged for three years i.e. total divided by three.
- C. **NETWORTH:** Shall be calculated based on the latest Audited Accounts as furnished for B-1 above. Net worth = Paid up share capital + Reserves. (Net worth is required to be evaluated in case of companies)
- D. **PROFIT:** shall be NET profit (PAT + Non cash expenditure viz. depreciation) earned during any one of the three financial years as in B-1 above
- E. Bidder shall submit above Pre-Qualification criteria format, duly filled-in, specifying respective annexure number against each criteria and furnish relevant document inclusive of Purchase order and Order completion certificate/Proof of Completion etc. in the respective annexures in their offer.

**BHARAT HEAVY ELECTRICALS LIMITED
POWER SECTOR WESTERN REGION, NAGPUR**

ENQUIRY NO. 1406070

DT.25.11.14

DUE DATE: 09.12.14

III. Technical Specifications

a) Pressure Transmitter				
Sl. No.	Range	No. of items required per Set	Type	Bidder's Compliance (Yes/No)
1	0 to 780 mm Hg	30	Absolute type	
2	0 to 6 kg/cm ²	10		
3	0 to 10 kg/cm ²	15		
4	0 to 25 kg/cm ²	20	Gauge type	
5	0 to 60 kg/cm ²	10		
6	0 to 100 kg/cm ²	25		
7	0 to 350 kg/cm ²	25		
8	Type	Smart Type		
9	Supply voltage	24V ± 5 Volts (DC)		
10	Out put	4-20 mA		
11	Accuracy	± 0.1% of F.S. or better		
12	Wetted material	SS 316 or equivalent		
13	Operating Temp	0-60 °C		
14	Local Display	Not Required		
15	Zero & span adjustment	Provision of zero adjustment through Hart communicator. Further, provision of 10% Full-scale span adjustment.		
16	Proof/Bursting pressure	1.5 times of the full-scale value as specified above.		
17	Process connection required	The party has to provide the transmitters with suitable SS process connection/adaptor of M 20 x 1.5 mm male.		
18	HART Communicator	One universal hand held HART communicator to be supplied per set.		
19	Manifold valve	Three way SS Manifold valves (Inlet M20 X 1.5 mm Male, Other end to be connected to Pressure Transmitter of M20 x 1.5 mm male process connector/adaptor) to be supplied for each transmitter (Drawing attached, Annexure-III). The sample of manifold shall be approved by BHEL prior to full lot manufacturing and delivery.		
20	Packing/carrying case	Items are to be supplied in properly packed hard portable carrying cases (maximum 05 no per carrying case fitted with foam etc.) for trouble free transportation from site to site.		
21	Calibration certificate	Minimum 03 points calibration certificate, up & down, to be supplied for each Pressure transmitter by the vendor from any accredited lab such as NABL/UKAS/NIST or National Laboratories of any country. Sample of required information on calibration certificate is attached as annexure –II.		

**BHARAT HEAVY ELECTRICALS LIMITED
POWER SECTOR WESTERN REGION, NAGPUR**

ENQUIRY NO. 1406070

DT.25.11.14

DUE DATE: 09.12.14

b) DP Transmitter				
Sl. No.	Qty. Required per Set	5	15	Bidder's Compliance (Yes/No)
1	Range Required	0-1.0 kg /cm ²	0-2.5 kg /cm ²	
2	Static Pressure	300 kg/cm ²	300 kg/cm ²	
3	Type	Smart Type		
4	Adjustable range from	0-0.2 kg /cm ² for full scale of 0-1.0 kg/cm ²	0-1.0 kg /cm ² for full scale of 0-2.5 kg/cm ²	
6	Loop voltage	24V ± 5V (DC)		
7	Local Display	Not Required		
8	Output	4-20 mA		
9	Operating Temp	0-60 °C		
10	Burst pressure	1.5 times static pressure		
11	Accuracy	± 0.05% of F.S. or better		
12	Zero & span adjustment	Provision of zero adjustment through Hart communicator. Further, provision of 10% Full-scale span adjustment.		
13	Process connection required	The party has to provide the transmitters with suitable SS process-connection/adaptor of M20x1.5mm male.		
14	Process wetted parts	316L SST or equivalent		
15	Flange	316 SST or equivalent for flange and adaptor bolts		
16	Manifold valve	Five way SS Manifold valves (Inlet M20 X 1.5 mm male, Other end to be connected to DP Transmitter of M20 x 1.5mm male process-connector/adaptor) to be supplied for each DP transmitter (Drawing attached, Annexure-III). The sample of manifold shall be approved by BHEL prior to full lot manufacturing and delivery.		
17	Packing/carrying case	Items are to be supplied in properly packed hard (minimum of fiber body) portable carrying cases (maximum 05 no per carrying case) for trouble free transportation from site to site.		
18	Calibration certificate	Minimum 03 points calibration certificate, up & down, to be supplied for each Differential Pressure transmitter by the vendor from any accredited lab such as NABL/UKAS/NIST or National Laboratories of any country. Sample of required information on calibration certificate is attached as annexure-II		

Note: Above specified item and quantities for Pressure Transmitter and DP Transmitter comprises of 1 set.

**BHARAT HEAVY ELECTRICALS LIMITED
POWER SECTOR WESTERN REGION, NAGPUR**

ENQUIRY NO. 1406070

DT.25.11.14

DUE DATE: 09.12.14

IV. TECHNO-COMMERCIAL TERMS & CONDITIONS

1. Product quoted by bidder should meet technical specification mentioned.
2. The quantities mentioned in Technical Specifications comprise of 1 Set of DP Transmitter, Pressure Transmitter & HART Communicator. Total of 5 sets are required as per table below:

Sl. No.	Destination	Sets Required
1.	BHEL-PSWR, Nagpur	2
2.	BHEL-PSNR, Noida	1
3.	BHEL-PSER, Kolkata	1
4.	BHEL-PSSR, Chennai	1

3. **Evaluation criteria:** Evaluation of Price bids shall be done for each destination (i.e. Nagpur, Noida, Kolkata & Chennai) individually and also on the basis of delivered cost, i.e. total cost to the BHEL, taking into consideration loadings, if any, and all available financial advantages, including those available from Owner, taxation authorities etc. (i.e. CENVAT credit on Excise duty/CVD, if bidder confirms to provide Excise/CVD Invoice).
4. Part offers shall be rejected, i.e. bidder should quote for Pressure Transmitter, DP Transmitter & HART Communicator together.
5. Prices shall be valid for 3 Months from the date of opening of technical bid.
6. Equipment should be supplied along with warranty certificate, O&M Manual, calibration certificate.
7. **Pre-dispatch inspection:** Supplier shall arrange for pre-dispatch inspection at their works/store/factory. Bidders quoted rates shall be inclusive of all necessary arrangements for pre-dispatch inspection at supplier's end. Pre-dispatch inspection call shall be raised 7 days in advance for complete set of instrument.
8. Equipment shall have warranty of 12 months from date of receipt at site. Materials supplied without warranty certificate shall not be accepted
9. **Payment Terms:** 80% payment of Supply value shall be made within 45 days from the date of receipt of complete set of material at destination (no part payment will be made) and on submission of complete documents to BHEL-PSWR Hqr., Nagpur. Balance 20% shall be released on submission of Performance Bank Guarantee (PBG) valid for 30 days beyond the Warranty period by supplier from any of the consortium Banks of BHEL for 10% of total PO value in prescribed format. The PBG confirmation charges shall be borne by vendor.
10. For any deviation sought in Payment terms by bidder w.r.t. payment term, following loading shall be followed during evaluation of price bids:
 - Base rate of State Bank of India (SBI) (as applicable on the date of bid opening; Techno-commercial bid opening in case of two part bids) + 6%; shall be considered for loading for the period of relaxation sought by bidders.

**BHARAT HEAVY ELECTRICALS LIMITED
POWER SECTOR WESTERN REGION, NAGPUR**

ENQUIRY NO. 1406070

DT.25.11.14

DUE DATE: 09.12.14

- On account of payment through LC, if insisted by bidder, all LC related Bank charges shall also be loaded for the deviation in (i) opening of LC by BHEL and (ii) period and amount of LC w.r.t. NIT norms, as per the prevailing bank rates.

11. Liquidated Damages/Penalty:

- LD shall be 0.5% of the total order value per week of delay or part thereof subject to a maximum of 10% of the total order value.
- In case bidder is not accepting the penalty clause for delayed supply, the offer of bidder shall be loaded to the extent to which it is not agreed by the bidder during price bid evaluation.

12. BHEL reserves the right to decide the successful bidder on the basis of Reverse Auction process. In such case all qualified bidders will be intimated regarding procedure/ modality for Reverse Auction process prior to Reverse Auction and price will be decided as per the rules for Reverse Auction. However, if reverse auction process is unsuccessful as defined in the RA rules/procedures, or for whatsoever reason, then the sealed 'PRICE BIDS' will be opened for deciding the successful bidder. BHEL's decision in this regard will be final and binding on bidder.

13. **Earnest Money Deposit:** Refundable, Non-interest bearing EMD of Rs.2,00,000/- (Rupees Two Lakhs only) is applicable for this Enquiry. EMD shall be paid ONLY by cash (as permissible under Income Tax Act) or Pay Order or Demand Draft in favour of "Bharat Heavy Electricals Limited" payable at Nagpur along with the technical bid. EMD given by all unsuccessful bidders shall be refunded on acceptance of award/PO by successful bidder. (Micro & Small Enterprises as per MSMED Act 2006 and Central/State-PSUs/Government departments are exempted from EMD).

14. **Contract Execution Bank Guarantee (CEBG)**

The successful bidder has to furnish a Contract Execution Bank Guarantee (CEBG) for 10% of the Total PO value in the prescribed format within 30 days from the date of PO but before L/C opening. CEBG shall be from one of the Consortium Banks of BHEL or from a reputed Bank and confirmed by any consortium bank of BHEL. All bank charges on account of issuance and confirmation of CEBG whether incurred in India or outside India will have to be borne by the vendor.

CEBG shall be kept valid until 30 days after the due date of delivery as per Purchase Order. In case of delay in delivery by supplier, CPBG shall be extended by supplier till the date of expected delivery until delivery is completed.

If supplier fails to submit the CEBG even within 60 days from the date of PO, BHEL reserves the right to cancel PO & forfeit the EMD given by supplier.

**BHARAT HEAVY ELECTRICALS LIMITED
POWER SECTOR WESTERN REGION, NAGPUR**

ENQUIRY NO. 1406070

DT.25.11.14

DUE DATE: 09.12.14

V. Instructions for filling the Price Bid

1. **Bidders' rate shall be exclusive of all taxes and duties.**
2. Packaging and Forwarding cost shall be included in Basic Cost.
3. Transit Insurance is in the scope of Supplier and shall be included in freight. Supplier shall insure at his cost the goods for all transit risk.
4. Octroi/Entry tax, if any shall be paid by BHEL on submission of original receipts.
5. Prices to be quoted in INR only.
6. Price bids shall be duly filled and signed for each destination separately.
7. Bidder shall mention item rates for each item separately.
8. Bidder must quote the price elements mentioned in price schedule, if any element left blank shall be construed as the price is included in all inclusive F.O.R. price.
9. Bidder shall fill the rates only in the Price format given by BHEL in Volume - II. Other papers or documents inscribing the rates of equipment shall be liable for rejection.

S. No.	DESCRIPTION OF T & C	T&C AS QUOTED IN THIS TENDER	ACCEPTED/ NOT ACCEPTED
1.	Place of delivery (for Indian Bidders)	F.O.R. As per ANNEXURE-I	
2.	Delivery period from the date of order	As per ANNEXURE-I	
3.	General conditions of the contract		
4.	Excise /CVD Invoices	<input type="checkbox"/> SHALL BE PROVIDED <input type="checkbox"/> SHALL NOT BE PROVIDED <ul style="list-style-type: none"> • Invoice should contain ECC details of supplier and buyer. BHEL ECC and TIN details shall be contained in purchase order. • If bidder confirms to provide Excise/CVD invoice, same shall be submitted within 1 month from the date of invoice for availing CENVAT credit failing which BHEL shall not be liable to reimburse Excise duty/CVD paid by supplier. 	
5.	MSE Certificate submitted	<input type="checkbox"/> Yes <input type="checkbox"/> No <input type="checkbox"/> Not Applicable	
6.	Manufacturing Facility Address		

**BHARAT HEAVY ELECTRICALS LIMITED
POWER SECTOR WESTERN REGION, NAGPUR**

ENQUIRY NO. 1406070

DT.25.11.14

DUE DATE: 09.12.14

VI. CERTIFICATE OF NO DEVIATION

TENDER SPECIFICATION No. : 1406070

I/WE, M/s

HEREBY CERTIFY THAT NOT WITHSTANDING ANY CONTRARY INDICATIONS / CONDITIONS ELSEWHERE IN OUR OFFER DOCUMENTS, I/WE HAVE NEITHER SET ANY TERMS AND CONDITIONS NOR THERE IS ANY DEVIATION TAKEN FROM THE CONDITIONS OF BHEL'S TENDER SPECIFICATIONS, EITHER TECHNICAL OR COMMERCIAL, AND I/WE AGREE TO ALL THE TERMS AND CONDITIONS MENTIONED IN BHEL'S TENDER SPECIFICATION WITH ASSOCIATED AMENDMENTS & CLARIFICATIONS.

I/WE ALSO HEREBY CONFIRM ANY TERMS AND CONDITIONS RECORDED/SET BY US IN ANY PART OF THE TENDER AND ITS RELATED REFERENCE ARE CONSIDERED NULL AND VOID AND WITHDRAWN BY US.

SIGNATURE OF THE TENDERER

DATE:

**BHARAT HEAVY ELECTRICALS LIMITED
POWER SECTOR WESTERN REGION, NAGPUR**

ENQUIRY NO. 1406070

DT.25.11.14

DUE DATE: 09.12.14

VII. CHECK LIST

NOTE: - Tenderers are required to fill in the following details and no column should be left blank

1.	Name and Address of the Tenderer		
2.	Details about type of the Firm/Company		
3.	Details of Contact person for this Tender	Name : Mr/Ms _____ Designation: _____ Telephone No: _____ Mobile No: _____ Email Id- _____	
		Bidders' Offer Page No	Bidder Reply
4.	Whether the format for compliance with PRE QUALIFICATION REQUIREMENT is understood and filled with proper supporting documents referenced in the specified format.		YES / NO
5.	Copy of executed Purchase Orders along with Proof of Completion to satisfy PQR		YES / NO
6.	Audited Profit and Loss Account for the last three years		YES / NO
7.	Whether all pages of the Tender documents are read, understood and signed with company seal.		YES / NO
8.	No Deviation Certificate duly signed with company seal.		YES / NO
9.	Annexures duly signed with company seal.		YES / NO
10.	Techno-Commercial Terms & Conditions sheet filled & duly signed with company seal.		YES / NO

NOTE: STRIKE OFF 'YES' OR 'NO', AS APPLICABLE

DATE:

AUTHORISED SIGNATORY
(With Name, Designation and Company seal)

**BHARAT HEAVY ELECTRICALS LIMITED
POWER SECTOR WESTERN REGION, NAGPUR**

ENQUIRY NO. 1406070

DT.25.11.14

DUE DATE: 09.12.14

Annexure-I

Sl. No.	Destination Address	Number of Set	Delivery Schedule
1	BHEL-PSWR SHREE MOHINI COMPLEX , 345 KINGSWAY, NAGPUR 440001	2	Within 4 months from date of P.O.
2	BHEL-PSNR HRDI&PSNR COMPLEX, PLOT No. 25, SECTOR 16- A, NOIDA-201301	1	Within 4 months from date of P.O.
3	BHEL-PSER BHEL BHAWAN, PLOT NO. 9/1, DJ BLOCK, SECTOR-II, SALT LAKE CITY, KOLKATA-700091	1	Within 4 months from date of P.O.
4	BHEL-PSSR NO.690 (OLD NO.474), ANNA SALAI, NANDANAM, CHENNAI-600035	1	Within 4 months from date of P.O.

CALIBRATION CERTIFICATE FORMAT

a) Pressure Transmitter

Sl. no	Applied pressure of Standard (In Kg/cm ²)	Transmitter output (UUC)					Measurement uncertainty
		Increasing direction (In mAmp)	Decreasing Direction (In mAmp)	Average (In mAmp)	Equivalent voltage Across 250Ω precision resistance installed in measurement circuit. (in Volts)	Equivalent pressure (in Kg/cm ²)	
1							
2							
3							

b) Differential Pressure Transmitter

Sl. no	Applied Diff. pressure of Standard (In Kg/cm ²)	Diffential Pressure Transmitter output (UUC)					Measurement uncertainty
		Increasing direction (In mAmp)	Decreasing Direction (In mAmp)	Average (In mAmp)	Equivalent voltage Across 250Ω precision resistance installed in measurement circuit. (in Volts)	Equivalent pressure (in Kg/cm ²)	
1							
2							
3							

- As per ISO 17025 next calibration due date should not be mentioned on calibration certificate.

Drawing not to scale

5 Way Manifold Drawing

Dimensions in mm

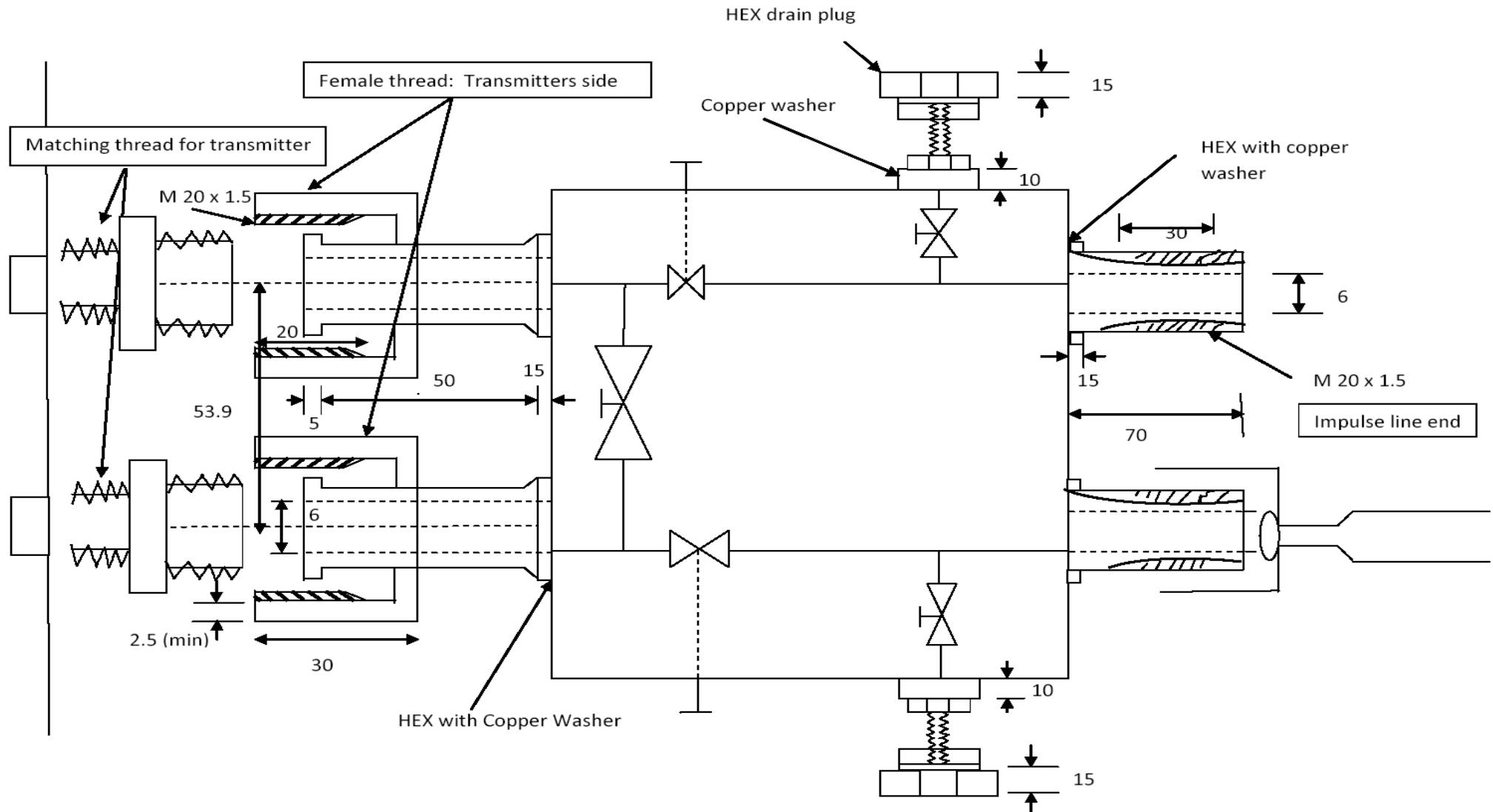

Dimensions in mm

3 Way Manifold Drawing

Drawing not to scale

