

TENDER ENQUIRY

Volume – IA: Technical Bid

Dear Sir,

Sealed offers are invited by the undersigned on behalf of BHARAT HEAVY ELECTRICALS LIMITED for the subject job. Please find enclosed tender documents as per following details:

Tender No: 1406110 Date 01-05-2015 comprising of following:

Salient Details of NIT		
S. No.	Issue	Description
1.0	Enquiry No.	1406110 dt.01/05/15
2.0	Supply Description	Supply of Differential Pressure Transmitter, Pressure Transmitter and HART Communicator as per Technical Specifications to BHEL-PSWR, PSNR, PSER & PSSR. Consignee details are as per Annexure-I
3.0	Details of Tender Document	
3.1	Volume - I A	Technical Bid – (Pre-Qualification Criteria & Technical Specification)
3.2	Volume - I B	General Conditions of the Contract
3.3	Volume – II	Price Bid
4.0	Issue of tender documents	From BHEL website (www.bhel.com) Tender documents can be downloaded from website till due/extended date of offer submission. Date of commencement: 01/05/15
4.0	Tender Due Date	Last date of submission of offer is 22-05-2015 Time: 15.00 Hrs. (IST) Opening of Tender 22-05-2015 Time: 15.30 Hrs. (IST) Place: BHEL-PSWR Hqr., Shree Mohini Complex, Nagpur-01 (Maharashtra), India Notes: (1) In case the due date of opening of tender becomes a non-working day, then the due date & time of offer submission and opening of tenders get extended to the next working day. (2) Bidder may depute representative to witness the opening of tender
5.0	EMD Amount	For Indigenous suppliers: INR 200,000/- (Rupees Two Lakhs Only) For Foreign Suppliers: Amount equivalent to INR 0.2 Million in USD/EURO/JPY/GBP currency
6.0	Tender Cost	Nil

**BHARAT HEAVY ELECTRICALS LIMITED
POWER SECTOR WESTERN REGION, NAGPUR**

ENQUIRY NO. 1406110

DT.01.05.15

DUE DATE: 22.05.15

7.0	Last date for seeking clarification	15/05/15
-----	-------------------------------------	----------

The offer shall be submitted as per the instructions of tender document and as detailed in this NIT. Bidders to note specifically that all pages of tender document, including these NIT pages of this particular tender together with subsequent correspondences shall be submitted by them, duly signed & stamped on each page, as part of offer. Rates/Price including discounts/rebates, if any, mentioned anywhere/in any form in the techno-commercial offer other than the Price Bid shall not be entertained.

Complete set of offer shall be sent to BHEL PSWR, Nagpur as per address given below as per following details.

I. Procedure for Submission of Tenders (Two -part Bid):

a) COVER-I (TECHNO-COMMERCIAL BID) – in sealed envelope	
1.	Offer forwarding/covering letter of the Tenderer
2.	EMD as per instruction in tender.
3.	Duly filled-in 'No deviation certificate' as per prescribed format. In case of any deviation, the same should be submitted separately for technical & commercial parts, indicating respective clauses of tender against which deviation is taken by bidder. It shall be specifically noted that deviation recorded elsewhere shall not be entertained.
4.	Techno-commercial offer enclosing supporting documents meeting Pre Qualifying Criteria / annexures / schedules /drawings etc. as required in line with prescribed format. It shall be specifically noted that all documents as per above shall be indexed properly.
5.	Price schedule: Un-priced but mentioning only quoted/unquoted against each item.
6.	All volumes of tender document pertinent for the subject job including NIT together with subsequent changes in the tender, correspondences etc., signed on all pages.
b) COVER-II (PRICE BID) – in sealed envelope	
c) COVER-III	
All two aforesaid covers in sealed condition shall be enclosed in this cover.	
All covers shall be super-scribed with	
i. Cover No.	
ii. Name of the job, tender document no. & due date of submission. ALONG WITH NAME & COMPLETE ADDRESS (FAX NO. CONTACT NOS) OF BIDDER and should be addressed to:	
AGM / Purchase	
Bharat Heavy Electricals Limited PSWR	
Shree Mohini Complex, 5 th Floor	
345 Kingsway, Nagpur – 440001	
Maharashtra	

**BHARAT HEAVY ELECTRICALS LIMITED
POWER SECTOR WESTERN REGION, NAGPUR**

ENQUIRY NO. 1406110

DT.01.05.15

DUE DATE: 22.05.15

SPECIAL NOTE:

1. Bidders' offer documents shall be paginated, signed and stamped in each page by your authorized representative. No overwriting / correction in tender documents by bidders shall be allowed. However, if correction is unavoidable, the same may be signed by authorized signatory.

All documents / annexure submitted with the offer shall be properly annexed and placed in respective places of the offer as per enclosure list mentioned in the covering letter. BHEL shall not be responsible for any missing documents.

Bids including all enclosures and supporting documents like catalogues, pamphlets, etc., shall be provided in ENGLISH language only.

2. No deviation with respect to tender clauses and no additional clauses/suggestions/clarification in Techno-Commercial bid/Price bid shall be considered by BHEL. Bidders are requested to comply with the same. Offers with deviations are liable for rejection.

3. BHEL reserves the right to accept or reject any or all Offers without assigning any reasons thereof. BHEL also reserves the right to cancel the Tender wholly or partly without assigning any reason thereof. Also BHEL shall not entertain any correspondence from bidders in this matter.

4. BHEL also reserve the right to reject the bidder with unsatisfactory past performance in the execution of a contract. BHEL's decision in this regard shall be final & binding.

5. For any clarification on the tender document, you may seek the same in writing from the office of the undersigned as per attached format only. Such letters should reach the office of the under signed positively by 15-05-2015.

6. Price bids of those bidders will be opened who will be qualified for the subject job on the basis of evaluation of Techno-commercial bids / pre-qualifying criteria and as considered suitable by BHEL.

7. While BHEL reserves the right to open the price bid of the offers in camera, the date & time to open the tender opening shall be intimated to the bidders in case BHEL decides it to be 'Public opening' and in such a case, one authorized representative of the bidder shall be allowed to attend.

8. Unsolicited discounts received after opening of techno-commercial bids shall not be considered for evaluation.

9. Suspension of Business dealings: BHEL reserves the right to take action against bidders who fail to perform or indulge in malpractices, by suspending business dealings with them as per extant guidelines. Details are available on BHEL website http://www.bhel.com/vender_registration/pdf/Suspension-of-Business-Dealings-with-Supplier-issued-Sept13_abridged.pdf

**BHARAT HEAVY ELECTRICALS LIMITED
POWER SECTOR WESTERN REGION, NAGPUR**

ENQUIRY NO. 1406110

DT.01.05.15

DUE DATE: 22.05.15

10. Order of Precedence

In the event of any ambiguity or conflict between the Tender Documents, the order of precedence shall be in the order below:

- a. Amendments/Clarifications/Corrigenda/Errata etc. issued in respect of the tender documents by BHEL
- b. Notice Inviting Tender (NIT)
- c. Price Bid – Volume - II
- d. Technical Conditions of Contract (TCC)—Volume-1A
- e. General Conditions of Contract (GCC) —Volume-1B

It may please be noted that guidelines/rules in respect of suspension of business dealings', 'Vendor evaluation format' etc. may undergo change from time to time and the latest one shall be followed.

Thanking you,

For Bharat Heavy Electricals Ltd

AGM/Purchase

**BHARAT HEAVY ELECTRICALS LIMITED
POWER SECTOR WESTERN REGION, NAGPUR**

ENQUIRY NO. 1406110

DT.01.05.15

DUE DATE: 22.05.15

Reverse Auction Terms & Conditions

Against this enquiry for the subject item/ system with detailed scope of supply as per enquiry specifications, BHEL may resort to "REVERSE AUCTION PROCEDURE" i.e., ON LINE BIDDING (THROUGH A SERVICE PROVIDER) in event of at least four techno-commercially qualified bidders. The philosophy followed for reverse auction shall be English Reverse (No ties). For the proposed reverse auction, technically and commercially acceptable bidders only shall be eligible to participate.

1. For the proposed reverse auction, technically and commercially acceptable bidders only shall be eligible to participate.
2. Those bidders who have given their acceptance for Reverse Auction (quoted against this tender enquiry) will have to necessarily submit 'online sealed bid' in the Reverse Auction. Non-submission of 'online sealed bid' by the bidder for any of the eligible items for which techno-commercially qualified, will be considered as tampering of the tender process and will invite action by BHEL as per extant guidelines in vogue.
3. BHEL will engage the services of a service provider who will provide all necessary training and assistance before commencement of on line bidding on internet.
4. In case of reverse auction, BHEL will inform the bidders the details of Service Provider to enable them to contact & get trained.
5. Business rules like event date, time, bid decrement, extension etc. also will be communicated through service provider for compliance.
6. Bidders have to fax the Compliance form before start of Reverse auction. Without this, the bidder will not be eligible to participate in the event.
7. In line with the NIT terms, BHEL will provide the calculation sheet if applicable (e.g., EXCEL sheet), which will help to arrive at "Total Cost to BHEL" like Packing & forwarding charges, Taxes and Duties, Freight charges, Insurance, Service Tax for Services and loading factors (for non-compliance to BHEL standard Commercial terms & conditions) for each of the bidder to enable them to fill-in the price and keep it ready for keying in during the Auction.
8. Reverse auction will be conducted on scheduled date & time.
9. At the end of Reverse Auction event, the lowest bidder value will be known on auction portal.
10. The lowest bidder has to fax/e-mail the duly signed and filled-in prescribed format for price breakup including that of line items, if required, (Annexure VII) as provided on case-to-case basis to Service provider within two working days of Auction without fail.
11. In case BHEL decides not to go for Reverse Auction procedure for this tender enquiry, the Price bids and price impacts, if any, already submitted and available with BHEL shall be opened as per BHEL's standard practice.
12. Bidders shall be required to read the "Terms and Conditions" section of the auctions site of Service provider, using the Login IDs and passwords given to them by the service provider before reverse auction event. Bidders should acquaint themselves of the "Business Rules of Reverse Auction", which will be communicated before the Reverse Auction.
13. If the Bidder or any of his representatives are found to be involved in Price manipulation/ cartel formation of any kind, directly or indirectly by communicating with other bidders, action as per extant BHEL guidelines, shall be initiated by BHEL and the results of the RA scrapped/ aborted.
14. The Bidder shall not divulge either his Bids or any other exclusive details of BHEL to any other party.
15. In case BHEL decides to go for reverse auction, the H1 bidder (whose quote is highest in online sealed bid) may not be allowed to participate in further RA process.

**BHARAT HEAVY ELECTRICALS LIMITED
POWER SECTOR WESTERN REGION, NAGPUR**

ENQUIRY NO. 1406110

DT.01.05.15

DUE DATE: 22.05.15

II. Pre-Qualification Criteria

QUALIFICATION REQUIREMENT FOR DP TRANSMITTERS, PRESSURE TRANSMITTERS & HART COMMUNICATOR			
S. NO	PRE QUALIFICATION CRITERIA	Bidders claim in respect of fulfilling the PQR Criteria	
		Name and Description of qualifying criteria	Order no. & proof of completion with Page no. of supporting document.
A	<p><u>Technical</u></p> <p>A.1) The Bidder should be an Original Equipment Manufacturer (OEM) of DP Transmitters, Pressure Transmitter and HART Communicator.</p> <p align="center">And</p> <p>A.2) Bidder must have executed following works in the last TWO (2) years as on latest date of bid submission:- Bidder should have supplied DP Transmitter and/or Pressure Transmitter worth of INR 6 Million (Equivalent USD/EURO/JPY/GBP or home currency for foreign suppliers) or more in a maximum of two purchase orders to any Customer.</p>	APPLICABLE	
B	<p><u>Financial Turnover:</u></p> <p>Bidders must have achieved an average annual financial turnover (Audited) of INR 31 Million (Equivalent USD/EURO/JPY/GBP or home currency for foreign suppliers) or more over last three Financial Years (FY). i.e. 2011-12, 2012-13, 2013-14 if 2013-14 is audited or 2010-2011, 2011-2012, 2012-2013 if Annual Accounts for FY 2013-14 are not audited.</p>	APPLICABLE	
C	<p><u>Price Bid Opening</u></p> <p>Note: Price Bids of only those bidders shall be opened who stand qualified after compliance of criteria A and B.</p>	APPLICABLE	BY BHEL

**BHARAT HEAVY ELECTRICALS LIMITED
POWER SECTOR WESTERN REGION, NAGPUR**

ENQUIRY NO. 1406110

DT.01.05.15

DUE DATE: 22.05.15

Explanatory Notes for QR

- A. *Supplied means bidder should have delivered on F.O.R Destination basis (for Indigenous suppliers) or FOB/FCA basis (for foreign suppliers).*
- B. *Bidder to submit Audited Balance Sheet and Profit and Loss Account for the respective years as indicated against B above along with all annexures.*
- C. *In case audited financial statements have not been submitted for all the three years as indicated against B above, then the applicable audited statements submitted by the bidders against the requisite three years, will be averaged for three years i.e. total divided by three.*
- D. *For PQR evaluation, exchange rates (TT selling rate of State Bank of India) as on scheduled date of tender opening (Part-I in case of two part bid) shall be considered.*
- E. *Bidder shall submit above Pre-Qualification criteria format, duly filled-in, specifying respective annexure number against each criteria and furnish relevant document inclusive of Purchase order and Order completion certificate/Proof of Completion etc. in the respective annexures in their offer.*

**BHARAT HEAVY ELECTRICALS LIMITED
POWER SECTOR WESTERN REGION, NAGPUR**

ENQUIRY NO. 1406110

DT.01.05.15

DUE DATE: 22.05.15

III. Technical Specifications

a) Pressure Transmitter				
Sl. No.	Range	No. of items required per Set	Type	Bidder's Compliance (Yes/No)
1	0 to 780 mm Hg	30	Absolute type	
2	0 to 6 kg/cm ²	10		
3	0 to 10 kg/cm ²	15		
4	0 to 25 kg/cm ²	20	Gauge type	
5	0 to 60 kg/cm ²	10		
6	0 to 100 kg/cm ²	25		
7	0 to 350 kg/cm ²	25		
8	Type	Smart Type		
9	Supply voltage	24V ± 5 Volts (DC)		
10	Out put	4-20 mA		
11	Accuracy	± 0.1% of F.S. or better		
12	Wetted material	SS 316 or equivalent		
13	Operating Temp	0-60 °C		
14	Local Display	Not Required		
15	Zero & span adjustment	Provision of zero adjustment through Hart communicator. Further, provision of 10% Full-scale span adjustment.		
16	Proof/Bursting pressure	1.5 times of the full-scale value as specified above.		
17	Process connection required	The party has to provide the transmitters with suitable SS process connection/adaptor of M 20 x 1.5 mm male.		
18	HART Communicator	One universal hand held HART communicator to be supplied per set.		
19	Manifold valve	Three way SS Manifold valves (Inlet M20 X 1.5 mm Male, Other end to be connected to Pressure Transmitter of M20 x 1.5 mm male process connector/adaptor) to be supplied for each transmitter (Drawing attached, Annexure-III). The sample of manifold shall be approved by BHEL prior to full lot manufacturing and delivery.		
20	Packing/carrying case	Items are to be supplied in properly packed hard portable carrying cases (maximum 05 no per carrying case fitted with foam etc.) for trouble free transportation from site to site.		
21	Calibration certificate	Minimum 03 points calibration certificate, up & down, to be supplied for each Pressure transmitter by the vendor from any accredited lab such as NABL/UKAS/NIST or National Laboratories of any country. Sample of required information on calibration certificate is attached as annexure –II.		

**BHARAT HEAVY ELECTRICALS LIMITED
POWER SECTOR WESTERN REGION, NAGPUR**

ENQUIRY NO. 1406110

DT.01.05.15

DUE DATE: 22.05.15

b) DP Transmitter				
Sl. No.	Qty. Required per Set	5	15	Bidder's Compliance (Yes/No)
1	Range Required	0-1.0 kg /cm ²	0-2.5 kg /cm ²	
2	Static Pressure	300 kg/cm ²	300 kg/cm ²	
3	Type	Smart Type		
4	Adjustable range from	0-0.2 kg /cm ² for full scale of 0-1.0 kg/cm ²	0-1.0 kg /cm ² for full scale of 0-2.5 kg/cm ²	
6	Loop voltage	24V ± 5V (DC)		
7	Local Display	Not Required		
8	Output	4-20 mA		
9	Operating Temp	0-60 °C		
10	Burst pressure	1.5 times static pressure		
11	Accuracy	± 0.05% of F.S. or better		
12	Zero & span adjustment	Provision of zero adjustment through Hart communicator. Further, provision of 10% Full-scale span adjustment.		
13	Process connection required	The party has to provide the transmitters with suitable SS process-connection/adaptor of M20x1.5mm male.		
14	Process wetted parts	316L SST or equivalent		
15	Flange	316 SST or equivalent for flange and adaptor bolts		
16	Manifold valve	Five way SS Manifold valves (Inlet M20 X 1.5 mm male, Other end to be connected to DP Transmitter of M20 x 1.5mm male process-connector/adaptor) to be supplied for each DP transmitter (Drawing attached, Annexure-III). The sample of manifold shall be approved by BHEL prior to full lot manufacturing and delivery.		
17	Packing/carrying case	Items are to be supplied in properly packed hard (minimum of fiber body) portable carrying cases (maximum 05 no per carrying case) for trouble free transportation from site to site.		
18	Calibration certificate	Minimum 03 points calibration certificate, up & down, to be supplied for each Differential Pressure transmitter by the vendor from any accredited lab such as NABL/UKAS/NIST or National Laboratories of any country. Sample of required information on calibration certificate is attached as annexure-II		

Note: Above specified item and quantities for Pressure Transmitter and DP Transmitter comprises of 1 set.

**BHARAT HEAVY ELECTRICALS LIMITED
POWER SECTOR WESTERN REGION, NAGPUR**

ENQUIRY NO. 1406110

DT.01.05.15

DUE DATE: 22.05.15

c) General Technical Requirement for DP/PT:	Bidder's Compliance (Yes/No)
<p>Normally, product specified in printed catalogue/brochure or website will be considered for evaluation. However, if any special model/instrument specification has been established for meeting required technical specifications; same should be offered along with all the supporting documents during the technical bid submission itself. Further, the offered special model will be considered only if it is accompanied by certification on original letter head from the principal manufacturer along with calibration certificate.</p>	

**BHARAT HEAVY ELECTRICALS LIMITED
POWER SECTOR WESTERN REGION, NAGPUR**

ENQUIRY NO. 1406110

DT.01.05.15

DUE DATE: 22.05.15

IV. TECHNO-COMMERCIAL TERMS & CONDITIONS

1. Product quoted by bidder should meet technical specification mentioned.
2. No Consortium bidding is allowed for this tender.
3. The quantities mentioned in Technical Specifications comprise of 1 Set of DP Transmitter, Pressure Transmitter & HART Communicator. Total of 5 sets are required as per table below:

Sl. No.	Destination	Sets Required
1.	BHEL-PSWR, Nagpur, India	2
2.	BHEL-PSNR, Noida, India	1
3.	BHEL-PSER, Kolkata, India	1
4.	BHEL-PSSR, Chennai, India	1

4. Part offers shall be rejected, i.e. bidder must quote for Pressure Transmitter, DP Transmitter & HART Communicator together.
5. Bidder shall quote prices on 'firm price' basis and shall be valid for 6 Months from the date of opening of technical bid.
6. **Price:**
 - a. Indian bidders should submit the prices in Indian Rupees only.
 - b. Foreign bidders shall submit their bid in USD/EURO/JPY/GBP only. The currency should be clearly indicated in the un-priced commercial bid as well as in the price bid.
7. **Terms of delivery:**
 - a. Indigenous Suppliers shall quote on FOR Destination basis only. Destination is as per Annexure-I in India.
 - b. Foreign Suppliers shall quote on CIP basis only. Delivery shall be on CIP Mumbai (India) Air-Port Basis. No other delivery terms shall be acceptable.

In case of CIP contracts, shipping arrangements including Insurance, from Port of Delivery to BHEL destinations would be to the account of BHEL.

8. The contractual delivery period will be reckoned from the date of P.O., which shall be binding on the contract. Suppliers shall quote their best delivery period. Delivery is the essence of all contracts for BHEL. Such of those suppliers, who quote for higher delivery, would be loaded with a factor of 1/2% per week, subject to a maximum of 2%. Such of those Suppliers whose offer is more than 4 weeks of the delivery specified by BHEL, would not be considered further in the tender, and their Price Bid would not be considered
9. **Opening of offers:** Tenders shall be received up to 1500 Hours (P.M) on the said due date and be opened on the same day at 1530 Hours (P.M). Tenders received after 1500 Hours (P.M) would not be opened. The times indicated are Indian Standard Time (IST).

10. If a Supplier submits single –part bid containing combined bids e.g. techno-commercial bid & price bid together, the bid is liable for rejection.

11. Evaluation criteria:

11..1 The price bids of the technically acceptable offers alone, contained in Cover II shall be opened.

11..2 **For Indigenous supplier:** Evaluation of Price bids shall be done on the basis of total landed cost, i.e. total cost to the BHEL, taking into consideration loadings (i.e. non-compliance to Payment, LD clauses, Delivery terms etc.), if any, and all available financial advantages, including those available from Owner, taxation authorities etc. (i.e. CENVAT credit on Excise duty, if bidder confirms to provide Excise Invoice).

Bidder to consider the benefit on CENVAT in their quoted basic price. BHEL is eligible to take CENVAT Credit as per CENVAT Credit Rule. Bidders eligible to issue Excise Invoice to BHEL for any materials either as manufacturers, first stage or second stage dealer under the Central Excise Act, Rules etc. must furnish the CENVATABLE ED amount as mentioned in price schedule. CENVATABLE ED amount which can be passed on to BHEL by the bidder will not be considered for evaluation of the offer.

11..3 **For Foreign Supplier:** In case of foreign bidders, the quoted CIP Mumbai (Airport) price shall be loaded by following factors to arrive at total F.O.R. Destination price:

- Custom Duty (including CVD & SAD) – as prevailing on date of price bid opening.
- Port handling/ clearing charges – @ 1% of CIP value.
- Inland freight and LC charges – @ 1% of CIP value.

For evaluation, exchange rate (TT selling rate of State Bank of India) as on date of tender opening (Part-I bid in case of two part bid) shall be considered. If the relevant day happens to be a bank holiday, then the forex rate as on the previous bank (SBI) working day shall be taken.

12. Payment Terms:

12..1 **For Indigenous supplier:** 80% payment of Supply value shall be made within 45 days from the date of receipt of complete set of material at destination (no part payment will be made) and on submission of complete documents to BHEL-PSWR Hqr., Nagpur. Balance 20% shall be released on submission of Performance Bank Guarantee (PBG) valid for 30 days beyond the Warranty period by supplier from any of the consortium Banks of BHEL for 10% of total PO value in prescribed format. The PBG confirmation charges shall be borne by vendor.

12..2 **For Foreign Supplier:** Foreign bidders can opt for payment (less agency commission, if applicable) through irrevocable and unconfirmed letter of credit (L/C). The L/C shall be opened by BHEL as per following: (i) Within 30 Days of receipt of CEBG, an irrevocable unconfirmed L/C will be opened for 30% of the payment towards supply, due on shipment.

Not earlier than 60 days before the shipment date, the value of this irrevocable unconfirmed L/C would be enhanced from 30 % to 80% of the Supply value of PO.

12..3 The above L/C can be negotiated after the Shipment against submission of Air Way Bill (AWB) and such other documents as mentioned in the PO. The above L/C will be valid for a period extending 21 days beyond the shipment date for negotiation of documents

**BHARAT HEAVY ELECTRICALS LIMITED
POWER SECTOR WESTERN REGION, NAGPUR**

ENQUIRY NO. 1406110

DT.01.05.15

DUE DATE: 22.05.15

Note:

- For indigenous suppliers, if the documents are routed through Bank, then all bank charges will be to vendor's account.
 - LC opening/ negotiation/ confirmation charges will be to vendor's account.
13. For any deviation sought in Payment terms by bidder w.r.t. payment term, following loading shall be followed during evaluation of price bids:
- Base rate of State Bank of India (SBI) (as applicable on the date of bid opening; Techno-commercial bid opening in case of two part bids) + 6%; shall be considered for loading for the period of relaxation sought by bidders.
 - On account of payment through LC, if insisted by bidder, all LC related Bank charges shall also be loaded for the deviation in (i) opening of LC by BHEL and (ii) period and amount of LC w.r.t. NIT norms, as per the prevailing bank rates.
14. Liquidated Damages/Penalty:
- LD shall be 0.5% of the total order value per week of delay or part thereof subject to a maximum of 10% of the total order value.
 - In case bidder is not accepting the penalty clause for delayed supply, the offer of bidder shall be loaded to the extent to which it is not agreed by the bidder during price bid evaluation.
15. BHEL reserves the right to decide the successful bidder on the basis of Reverse Auction process. In such case all qualified bidders will be intimated regarding procedure/ modality for Reverse Auction process prior to Reverse Auction and price will be decided as per the rules for Reverse Auction. However, if reverse auction process is unsuccessful as defined in the RA rules/procedures, or for whatsoever reason, then the sealed 'PRICE BIDS' will be opened for deciding the successful bidder. BHEL's decision in this regard will be final and binding on bidder.
16. Equipment should be supplied along with warranty certificate, O&M Manual & calibration certificate.
17. Equipment shall have warranty of 12 months from date of receipt at site. Materials supplied without warranty certificate shall not be accepted
18. **Pre-dispatch inspection:** Supplier shall arrange for pre-dispatch inspection at their works/store/factory. Bidders quoted rates shall be inclusive of all necessary arrangements for pre-dispatch inspection at supplier's end. Pre-dispatch inspection call shall be raised 7 days in advance for complete set of instrument.
19. **Earnest Money Deposit:** Refundable, Non-interest bearing EMD of INR 2,00,000/- (Rupees Two Lakhs only) (Equivalent USD/EURO/JPY/GBP for foreign suppliers) is applicable for this Enquiry. EMD shall be paid ONLY by cash (as permissible under Income Tax Act) or Pay Order or Demand Draft in favour of "Bharat Heavy Electricals Limited" payable at Nagpur, India along with the technical bid, failing which bidder's offer is liable for rejection. EMD given by all unsuccessful bidders shall be refunded on acceptance of award/PO by successful bidder. (Micro & Small Enterprises as per MSMED Act 2006 and Central/State-PSUs/Government departments are exempted from EMD).

**BHARAT HEAVY ELECTRICALS LIMITED
POWER SECTOR WESTERN REGION, NAGPUR**

ENQUIRY NO. 1406110

DT.01.05.15

DUE DATE: 22.05.15

EMD by bidder will be forfeited as per tender documents, if after opening the tender bidder revokes his tender within validity period or increases his earlier quoted rates.

20. Contract Execution Bank Guarantee (CEBG)

The successful bidder has to furnish a Contract Execution Bank Guarantee (CEBG) for 10% of the Total PO value in the prescribed format within 30 days from the date of PO but before L/C opening. CEBG shall be from one of the Consortium Banks of BHEL or from a reputed Bank and confirmed by any consortium bank of BHEL. All bank charges on account of issuance and confirmation of CEBG whether incurred in India or outside India will have to be borne by the vendor.

CEBG shall be kept valid until 30 days after the due date of delivery as per Purchase Order. In case of delay in delivery by supplier, CPBG shall be extended by supplier till the date of expected delivery until delivery is completed.

If supplier fails to submit the CEBG even within 60 days from the date of PO, BHEL reserves the right to cancel PO & forfeit the EMD given by supplier.

21. Role of Agents:

BHEL shall deal directly with foreign vendors, wherever required, for procurement of goods. However, if the foreign principal desires to avail of the services of an Indian agent, then the foreign principal should ensure compliance to regulatory guidelines - which require mandatory submission of an Agency Agreement.

22. It shall be incumbent on the Indian agent and the foreign principal to adhere to the relevant guidelines of Government of India, issued from time to time.

23. The Agency Agreement should specify the precise relationship between the foreign OEM / foreign principal and their Indian agent and their mutual interest in the business. All services to be rendered by agent/associate, whether of general nature or in relation to the particular contract, must be clearly stated by the foreign supplier/ Indian agent. Any payment, which the agent or associate receives in India or abroad from the OEM, whether as commission or as a general retainer fee should be brought on record in the Agreement and be made explicit in order to ensure compliance to laws of the country.

24. Any agency commission to be paid by BHEL to the Indian agent shall be in Indian currency only.

25. Tax deduction at source is applicable to the agency commission paid to the Indian agent as per the prevailing rules.

26. In the absence of any agency agreement, BHEL shall not deal with any Indian agent (authorized representatives / associate / consultant, or by whatever name called) and shall deal directly with the foreign principal only for all correspondence and business purposes.

27. The "Guidelines for Indian Agents of Foreign Suppliers" enclosed at annexure - 'V' shall apply in all such cases.

28. The supply and execution of the Purchase Order (including indigenous supplies/service) shall be in the scope of the OEM/ foreign principal. The OEM/ foreign principal should submit their offer inclusive of all indigenous supplies/ services and evaluation will be based on 'total cost to BHEL'. In case OEM/ foreign principal recommends placement of order(s) towards indigenous portion of supplies/ services

**BHARAT HEAVY ELECTRICALS LIMITED
POWER SECTOR WESTERN REGION, NAGPUR**

ENQUIRY NO. 1406110

DT.01.05.15

DUE DATE: 22.05.15

on Indian supplier(s)/ agent on their behalf, the credentials/ capacity/ capability of the Indian supplier(s)/ agent to make the supplies/ services shall be checked by BHEL as per the extant guidelines of Supplier Evaluation, Approval & Review Procedure (SEARP), before opening of price bids. In this regard, details may be checked as per Annexure-VI (copy enclosed). It will be the responsibility of the OEM/ foreign principal to get acquainted with the evaluation requirements of Indian supplier/ agent as per SEARP available on www.bhel.com.

29. The responsibility for successful execution of the contract (including indigenous supplies/ services) lies with the OEM/ foreign principal. All bank guarantees to this effect shall be in the scope of the OEM/foreign principal.

**BHARAT HEAVY ELECTRICALS LIMITED
POWER SECTOR WESTERN REGION, NAGPUR**

ENQUIRY NO. 1406110

DT.01.05.15

DUE DATE: 22.05.15

V. Instructions for filling the Price Bid

1. **Bidders' rate shall be exclusive of all taxes and duties.**
2. Packaging and Forwarding cost shall be included in Basic Cost.
3. Transit Insurance is in the scope of Supplier and shall be included in freight. Supplier shall insure at his cost the goods for all transit risk.
4. Octroi/Entry tax, if any shall be paid by BHEL on submission of original receipts.
5. Prices to be quoted in **INR only (Volume-II A)** for Indigenous suppliers **and USD/EURO/JPY/GBP currency (Volume-II B)** for Foreign suppliers.
6. Price bids shall be duly filled and signed for as applicable for Indian/Foreign OEM.
7. Bidder shall mention item rates for each item separately.
8. Bidder must quote the price elements mentioned in price schedule, if any element left blank shall be construed as the price is included in all inclusive F.O.R./C.I.P. price.
9. Bidder shall fill the rates only in the Price format given by BHEL in Volume - II. Other papers or documents inscribing the rates of equipment shall be liable for rejection.

S. No.	DESCRIPTION OF T & C	T&C AS QUOTED IN THIS TENDER	ACCEPTED/ NOT ACCEPTED
1.	Place of delivery <ul style="list-style-type: none"> • For Indigenous suppliers • For foreign suppliers 	F.O.R. as per ANNEXURE-I CIF Mumbai Airport, India	
2.	Delivery period from the date of order	As per ANNEXURE-I	
3.	General conditions of the contract		
4.	Excise Invoice (Strike off, whichever not applicable)	<input type="checkbox"/> SHALL BE PROVIDED <input type="checkbox"/> SHALL NOT BE PROVIDED <ul style="list-style-type: none"> • Invoice should contain ECC details of supplier and buyer. BHEL ECC and TIN details shall be contained in purchase order. • If bidder confirms to provide Excise invoice, same shall be submitted within 1 month from the date of invoice for availing CENVAT credit failing which BHEL shall not be liable to reimburse Excise duty paid by supplier. 	
5.	MSE Certificate submitted	<input type="checkbox"/> Yes <input type="checkbox"/> No <input type="checkbox"/> Not Applicable	
6.	Manufacturing Facility Address		

**BHARAT HEAVY ELECTRICALS LIMITED
POWER SECTOR WESTERN REGION, NAGPUR**

ENQUIRY NO. 1406110

DT.01.05.15

DUE DATE: 22.05.15

VI. CERTIFICATE OF NO DEVIATION

TENDER SPECIFICATION No. : 1406110

I/WE, M/s

HEREBY CERTIFY THAT NOT WITHSTANDING ANY CONTRARY INDICATIONS / CONDITIONS ELSEWHERE IN OUR OFFER DOCUMENTS, I/WE HAVE NEITHER SET ANY TERMS AND CONDITIONS NOR THERE IS ANY DEVIATION TAKEN FROM THE CONDITIONS OF BHEL'S TENDER SPECIFICATIONS, EITHER TECHNICAL OR COMMERCIAL, AND I/WE AGREE TO ALL THE TERMS AND CONDITIONS MENTIONED IN BHEL'S TENDER SPECIFICATION WITH ASSOCIATED AMENDMENTS & CLARIFICATIONS.

I/WE ALSO HEREBY CONFIRM ANY TERMS AND CONDITIONS RECORDED/SET BY US IN ANY PART OF THE TENDER AND ITS RELATED REFERENCE ARE CONSIDERED NULL AND VOID AND WITHDRAWN BY US.

SIGNATURE OF THE TENDERER

DATE:

**BHARAT HEAVY ELECTRICALS LIMITED
POWER SECTOR WESTERN REGION, NAGPUR**

ENQUIRY NO. 1406110

DT.01.05.15

DUE DATE: 22.05.15

VII. PROFORMA FOR DEVIATION TO TENDER TERMS & CONDITIONS

a) Technical

Sl. No.	Clause	Deviation

b) Commercial

Sl. No.	Clause	Deviation

SIGNATURE OF THE TENDERER

DATE:

**BHARAT HEAVY ELECTRICALS LIMITED
POWER SECTOR WESTERN REGION, NAGPUR**

ENQUIRY NO. 1406110

DT.01.05.15

DUE DATE: 22.05.15

VIII. FORMAT FOR SEEKING CLARIFICATION

(To be typed and submitted in the Letter Head of the Company/Firm of Bidder)

To,

(Write Name & Address of Officer of BHEL inviting the Tender)

Dear Sir,

Sub: **Request for Clarification**

Ref: 1) NIT/Tender Specification No:,
2) All other pertinent issues till date

Sl. No.	Reference clause of Tender document	Existing Provision	Bidder's query	BHEL Clarification

Yours faithfully,

(Signature, date & seal of Authorized Representative of the Bidder)

**BHARAT HEAVY ELECTRICALS LIMITED
POWER SECTOR WESTERN REGION, NAGPUR**

ENQUIRY NO. 1406110

DT.01.05.15

DUE DATE: 22.05.15

IX. CHECK LIST

NOTE: - Tenderers are required to fill in the following details and no column should be left blank

1.	Name and Address of the Tenderer		
2.	Details about type of the Firm/Company		
3.	Details of Contact person for this Tender	Name : Mr/Ms _____ Designation: _____ Telephone No: _____ Mobile No: _____ Email Id- _____	
		Bidders' Offer Page No	Bidder Reply
4.	Whether the format for compliance with PRE QUALIFICATION REQUIREMENT is understood and filled with proper supporting documents referenced in the specified format.		YES / NO
5.	Copy of executed Purchase Orders along with Proof of Completion to satisfy PQR		YES / NO
6.	Audited Profit and Loss Account for the last three years		YES / NO
7.	Whether all pages of the Tender documents are read, understood and signed with company seal.		YES / NO
8.	No Deviation Certificate duly signed with company seal.		YES / NO
9.	Annexures duly signed with company seal.		YES / NO
10.	Techno-Commercial Terms & Conditions sheet filled & duly signed with company seal.		YES / NO
11.	Enclosed Un-priced Price bid duly signed with company seal in Cover-I as per Procedure for submission of Tenders		YES / NO

NOTE: STRIKE OFF 'YES' OR 'NO', AS APPLICABLE

DATE:

AUTHORISED SIGNATORY
(With Name, Designation and Company seal)

**BHARAT HEAVY ELECTRICALS LIMITED
POWER SECTOR WESTERN REGION, NAGPUR**

ENQUIRY NO. 1406110

DT.01.05.15

DUE DATE: 22.05.15

Annexure-I

Sl. No.	Consignee Address (Destination)	Number of Set	Delivery Schedule
1	BHEL-PSWR SHREE MOHINI COMPLEX , 345 KINGSWAY, NAGPUR 440001, MAHARASHTRA (INDIA)	2	Within 4 months from date of P.O.
2	BHEL-PSNR HRDI&PSNR COMPLEX, PLOT No. 25, SECTOR 16- A, NOIDA-201301 (INDIA)	1	Within 4 months from date of P.O.
3	BHEL-PSER BHEL BHAWAN, PLOT NO. 9/1, DJ BLOCK, SECTOR-II, SALT LAKE CITY, KOLKATA-700091 WEST BENGAL (INDIA)	1	Within 4 months from date of P.O.
4	BHEL-PSSR NO.690 (OLD NO.474), ANNA SALAI, NANDANAM, CHENNAI-600035 TAMIL NADU (INDIA)	1	Within 4 months from date of P.O.

CALIBRATION CERTIFICATE FORMAT

a) Pressure Transmitter

Sl. no	Applied pressure of Standard (In Kg/cm ²)	Transmitter output (UUC)					Measurement uncertainty
		Increasing direction (In mAmp)	Decreasing Direction (In mAmp)	Average (In mAmp)	Equivalent voltage Across 250Ω precision resistance installed in measurement circuit. (in Volts)	Equivalent pressure (in Kg/cm ²)	
1							
2							
3							

b) Differential Pressure Transmitter

Sl. no	Applied Diff. pressure of Standard (In Kg/cm ²)	Diffential Pressure Transmitter output (UUC)					Measurement uncertainty
		Increasing direction (In mAmp)	Decreasing Direction (In mAmp)	Average (In mAmp)	Equivalent voltage Across 250Ω precision resistance installed in measurement circuit. (in Volts)	Equivalent pressure (in Kg/cm ²)	
1							
2							
3							

- As per ISO 17025 next calibration due date should not be mentioned on calibration certificate.

5 Way Manifold Drawing

Dimensions in mm

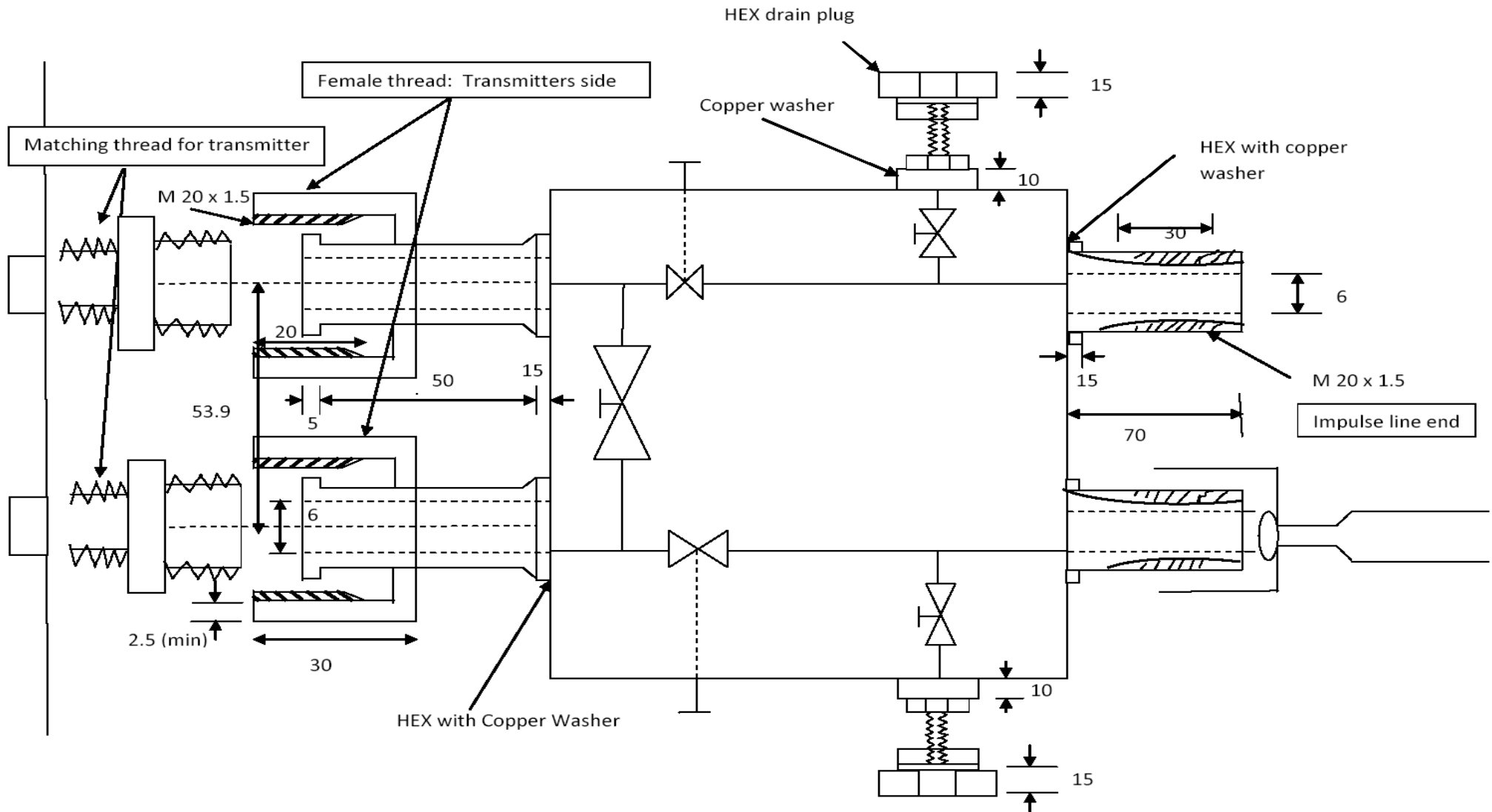

Dimensions in mm

3 Way Manifold Drawing

Drawing not to scale

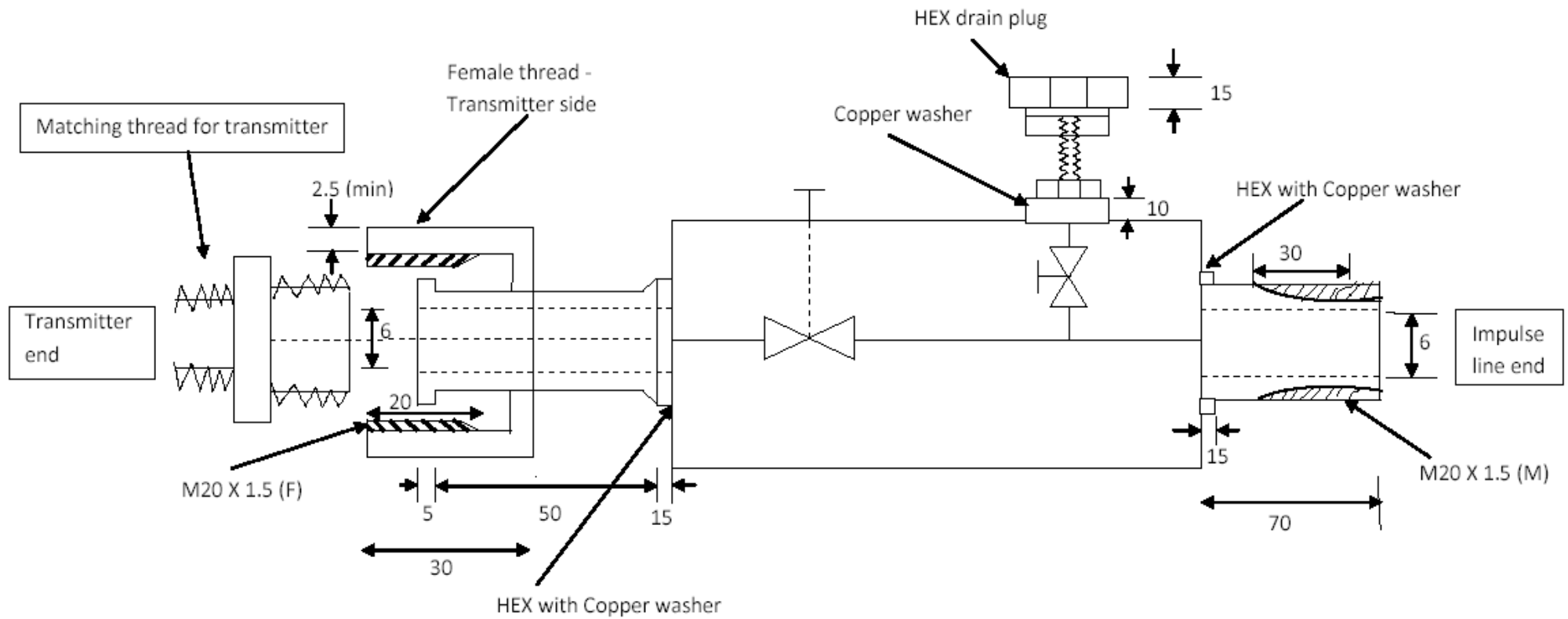

Annexure-IV

DECLARATION FOR RELATION IN BHEL

(To be typed and submitted in the Letter Head of the Company/Firm of Bidder failing which the offer of Bidder is liable to be summarily rejected)

To,

(Write Name & Address of Officer of BHEL inviting the Tender)

Dear Sir,

Sub: **Declaration for relation in BHEL**

Ref: 1) NIT/Tender Specification No:,

I/We hereby submit the following information pertaining to relation/relatives of Proprietor/Partner(s) /Director(s) employed in BHEL.

Tick (√) any one as applicable:

1. The Proprietor, Partner(s), Director(s) of our Company/Firm DO NOT have any relation or relatives employed in BHEL

OR

2. The Proprietor, Partner(s), or Director(s) of our Company/Firm HAVE relation/relatives employed in BHEL and their particulars are as below:

(i)

(ii)

Signature of the Authorized Signatory

Note:

1. Attach separate sheet, if necessary.

2. If BHEL Management comes to know at a later date that the information furnished by the Bidder is false, BHEL reserves the right to take suitable against the Bidder/Contractor.

Annexure-V

Guideline for Indian Agents of Foreign Suppliers:

- 1.1 There shall be compulsory registration of agents for this Tender. An agent who is not registered with BHEL shall apply for registration in the registration form in line with SEARP.
- 1.2 Registered agents will file an authenticated Photostat copy duly attested by a Notary Public/Original certificate of the Principal confirming the agency agreement and giving the status being enjoyed by the agent and the commission/ remuneration/ salary/ retainership being paid by the principal to the agent before the placement of order by BHEL.
- 1.3 Wherever the Indian representatives have communicated on behalf of their principals and the foreign parties have stated that they are not paying any commission to the Indian agents, and the Indian representative is working on the basis of salary or as retainer, a written declaration to this effect should be submitted by the party (i.e. Principal) before finalizing the order.
- 1.4 **Disclosure of particulars of agents/ representatives in India, if any.**
 - 1.4.1 Tenderers of Foreign nationality shall furnish the following details in their offers:
 - a. The Bidder(s)/ Contractor(s) of foreign origin shall disclose the name and address of the agents/ representatives in India if any and the extent of authorization and authority given to commit the Principals. In case the agent/ representative be a foreign Company, it shall be confirmed whether it is existing Company and details of the same shall be furnished.
 - b. The amount of commission/ remuneration included in the quoted price(s) for such agents/ representatives in India.
 - c. Confirmation of the Tenderer that the commission/ remuneration, if any, payable to his agents/ representatives in India, may be paid by BHEL in Indian Rupees only.
 - 1.4.2 Tenderers of Indian Nationality shall furnish the following details in their offers:
 - a. The Bidder(s)/ Contractor(s) of Indian Nationality shall furnish the name and address of the foreign principals, if any, indicating their nationality as well as their status, i.e. whether manufacturer or agents of manufacturer holding the Letter of Authority of the Principal specifically authorizing the agent to make an offer in India in response to tender either directly or through the agents/ representatives.
 - b. The amount of commission/ remuneration included in the price (s) quoted by the Tenderer for himself.
 - c. Confirmation of the foreign principals of the Tenderer that the commission/ remuneration, if any, reserved for the Tenderer in the quoted price(s), may be paid by BHEL in India in equivalent Indian Rupees on satisfactory completion of the Project or supplies of Stores and Spares in case of operation items.
 - 1.4.3 In either case, in the event of contract materializing, the terms of payment will provide for payment of the commission/ remuneration, if any payable to the agents/ representatives in India in Indian Rupees on expiry of 90 days after the discharge of the obligations under the contract.

Tax deduction at source is applicable to the agency commission paid to the Indian agent as per the prevailing rules.

In absence of agency agreement, BHEL shall not deal with any Indian agent (authorized representatives/associate/consultant, or by whatever name called) and shall deal directly with the foreign principal only for all correspondences and business purposes.
 - 1.4.4 Failure to furnish correct and detailed information as called for in sl. no.1.4 above will render the concerned tender liable to rejection or in the event of a contract materializing, the same liable to termination by BHEL. Besides this there would be a penalty of banning business dealings with BHEL or damage or payment of a named sum.

**BHARAT HEAVY ELECTRICALS LIMITED
POWER SECTOR WESTERN REGION, NAGPUR**

ENQUIRY NO. 1406110

DT.01.05.15

DUE DATE: 22.05.15

Annexure-VI

SEARP (SRF) Clause No.	Detail
	Name & Address of the firm
1.0	Products/Systems/Services being considered for
2.0	General Information
2.2	Name of the chief Executive
2.3	Details of authorized signatory
3.0	Ownership Information
3.1	Type of firm
3.2	Name of the Business <ul style="list-style-type: none"> • Attach authorization letter and agency agreement from Principal (from whom capital equipment is procured) • Attach copy of declaration from Foreign Principal for total guarantee/warranty of indigenous supplies
3.3	Year of establishment
3.4	Year of commencement of business
4.0	Registration particulars
4.1	Permanent Account No.
4.2/4.3	Sales Tax/TIN no.
4.6	Service Tax no. (in case of E&C)
5.0	Organizational strength
6.0	Other Particulars
6.1	If the company is already registered with other units
6.2	Directors/Partners, if related to any BHEL Employee
6.9	If any Ex BHEL Person employed by the Company
6.12	Details of pending legal issues with BHEL
6.13	Bank Account information
9.0	Financial information
9.6	Sales/Turnover details of Last 3 years (or from the date of incorporation whichever is less)

**BHARAT HEAVY ELECTRICALS LIMITED
POWER SECTOR WESTERN REGION, NAGPUR**

ENQUIRY NO. 1406110

DT.01.05.15

DUE DATE: 22.05.15

Annexure-VII

BANK GUARANTEE FOR CONTRACT EXECUTION BANK GUARANTEE & WARRANTY PERIOD

B.G. NO.

Date:

This deed of Guarantee made this ----- day of -----two thousand ---- by <Name and Address of Bank> hereinafter called the "The Guarantor" (which expression shall unless repugnant to the context or meaning thereof be deemed to include its successors and assigns) in favour of M/s Bharat Heavy Electrical Limited (A Govt. of India Undertaking) a company incorporated under the Companies Act, 1956, having its registered office at BHEL House, Siri Fort, Asiad, New Delhi – 110049 through its unit at <Address of Power Sector Region¹> hereinafter called "The Company" (which expression shall unless repugnant to the context or meaning thereof be deemed to include its successors and assigns)

WHEREAS < Contractor's Name and Address> (hereinafter referred to as the Contractor) have entered into a contract arising out of Letter of Intent no. < P.O. REF & Date > (hereinafter referred to as "the contract") for < Name of Work > with the company.

AND WHEREAS the contract inter-alia provides that the contractor shall furnish to the company a sum of Rs.----- (Rupees-----) towards security deposit for due and faithful performance of the contract in the form and manner specified therein.

AND WHEREAS the contractor has approached the Guarantor and in consideration of the arrangement arrived at between the contractor and the Guarantor, the Guarantor has agreed to give the Guarantee as hereinafter mentioned in favour of the company.

The Guarantor do hereby guarantee to the company the due and faithful performance, observance or discharge of the Contract by the contractor and further unconditionally and irrevocably undertake to pay to the Company without demur and merely on a demand, to the extent of Rs.------(Rupees----- ----) against any claim by the company on them for any loss, damage, costs, charges and expenses caused to or suffered by the company by reasons of the contractor making any default in the performance, observance or discharge of the terms, conditions, stipulations or undertakings or any of them as contained in the contract.

The decision of the company whether any default has occurred or has been committed by the contractor in the performance, observance or discharge of any of the terms, conditions, stipulations or undertakings or any one of them as contained in the contract and / or as to the extent of loss, damage, costs, charges and expenses caused to or suffered by the company by reason of the contractor making any default in the performance, observance or discharge of any of the terms, conditions, stipulations or undertakings or any one of them shall be conclusive and binding on the Guarantor irrespective of the fact whether the contractor admits or denies the default or questions

**BHARAT HEAVY ELECTRICALS LIMITED
POWER SECTOR WESTERN REGION, NAGPUR**

ENQUIRY NO. 1406110

DT.01.05.15

DUE DATE: 22.05.15

the correctness of any demand made by the company in any Court, Tribunal or Arbitration proceedings or before any other Authority.

The company shall have the fullest liberty without affecting in any way the liability of the Guarantor under this Guarantee, from time to time to vary any of the terms and conditions of the contract or extend time of performance by the contractor or to postpone for any time and from time to time any of the powers exercisable by it against the contractor and either enforce or forbear from enforcing any of the terms and conditions governing the contract or securities available to the company and the Guarantor shall not be released from its liability under these presents by any exercise by the company of the liberty with reference to the matters aforesaid or by reasons of time being given to the contractor or any other forbearance, act or commission on the part of the company or any indulgence by the company to the contractor or any other matter or thing whatsoever which under the law relating to sureties would, but for this provision have the effect of so releasing the Guarantor from its liability under this guarantee.

The Guarantor further agrees that the Guarantee herein contained shall remain in full force and effect during the period that would be taken for the performance of the contract and its claim satisfied or discharged and till the company certifies that the terms and conditions of the contract have been fully and properly carried out by the contractor and accordingly discharges this Guarantee, subject however, that the company shall have no claim under this Guarantee after ----- i.e. (3 months more than the present date of validity of Bank Guarantee unless the date of validity of this Bank Guarantee is further extended from time to time, as the case may be) unless a notice of the claim under this Guarantee has been served on the Guarantor before the expiry of the said period in which case the same shall be enforceable against the Guarantor notwithstanding the fact that the same is enforced after the expiry of the said period.

The Guarantor undertakes not to revoke this Guarantee during the period it is in force except with the previous consent of the Company in writing and agrees that any liquidation or winding up or insolvency or dissolution or any change in the constitution of the contractor or the Guarantor shall not discharge the Guarantor's liability hereunder.

It shall not be necessary for the company to proceed against the contractor before proceeding against the Guarantor and the Guarantee herein contained shall be enforceable against them notwithstanding any security which the Company may have obtained or obtain from the Contractor shall at the time when proceedings are taken against the Guarantor hereunder be outstanding or unrealized.

Notwithstanding anything contained herein before, our liability under the Guarantee is restricted to Rs.----- (Rupees-----). Our guarantee shall remain in force until -----, i.e. (the present date of validity of Bank Guarantee unless the date of validity of this Bank Guarantee is further extended from time to time) unless a claim or demand under this guarantee is made against us on or before -----

**BHARAT HEAVY ELECTRICALS LIMITED
POWER SECTOR WESTERN REGION, NAGPUR**

ENQUIRY NO. 1406110

DT.01.05.15

DUE DATE: 22.05.15

----- (3 Months more than the validity date) we shall be discharged from our liabilities under this Guarantee thereafter.

Any claim or dispute arising under the terms of this document shall only be enforced or settled in the courts of at < Name of place² > only.

The Guarantor hereby declares that it has power to execute this guarantee and the executant has full powers to do so on behalf of the Guarantor.

IN WITNESS whereof the ----- (Bank) has hereunto set and subscribed its hand the day, month and year first, above written.

(Name of the Bank)

Signed for and on behalf of the Bank

(Designation of the Authorized Person Signing the Guarantee)

(Signatory No. -----)

DATED:

SEAL

=====

Notes:

1. **Address of Power Sector Regions (Consignee)** is as below:

- PSNR : Bharat Heavy Electricals Limited, Power Sector Northern Region, HRDI & PSNR Complex, Plot No 25, Sector 16-A, Noida – 201 301 (Uttar Pradesh)
- PSER : Bharat Heavy Electricals Limited, Power Sector Eastern Region, BHEL Bhawan, Plot No 9/1, DJ Block, Sector-II, Salt lake City, Kolkata – 700 091
- PSWR: Bharat Heavy Electricals Limited, Power Sector Western Region, Shree Mohini Complex, 345 Kingsway, Nagpur 440 001
- PSSR: Bharat Heavy Electricals Limited, Power Sector Southern Region, 690, Anna Salai, Nandanam, Chennai 600 035

2. **Name of place (for jurisdiction of Courts)** is as below:

- PSNR : Delhi
- PSER : Kolkata
- PSWR: Nagpur
- PSSR : Chennai

3. The BG shall be executed on non-judicial stamp papers of adequate value procured in the name of the Bank in the State where the Bank is located.

4. The BG is required to be sent by the executing Bank directly to BHEL at the address where tender is submitted / accepted under sealed cover.